



TWOSE SERIES REACH ARMS  
**TW 52-2 Models**  
Operation Manual

Publication No.864

February 2017

# IMPORTANT VERIFICATION OF WARRANTY REGISTRATION



## DEALER WARRANTY INFORMATION & REGISTRATION VERIFICATION

It is imperative that the selling dealer registers this machine with McConnel Limited before delivery to the end user – failure to do so may affect the validity of the machine warranty.

To register machines go to the McConnel Limited web site at [www.mcconnel.com](http://www.mcconnel.com), log onto 'Dealer Inside' and select the 'Machine Registration button' which can be found in the Service Section of the site. Confirm to the customer that the machine has been registered in the section below.

Should you experience any problems registering a machine in this manner please contact the McConnel Service Department on 01584 875848.

### Registration Verification

Dealer Name: .....
Dealer Address: .....
Customer Name: .....
Date of Warranty Registration: ...../...../..... Dealer Signature: .....

### NOTE TO CUSTOMER / OWNER

*Please ensure that the above section above has been completed and signed by the selling dealer to verify that your machine has been registered with McConnel Limited.*

**IMPORTANT:** During the initial 'bedding in' period of a new machine it is the customer's responsibility to regularly inspect all nuts, bolts and hose connections for tightness and re-tighten if required. New hydraulic connections occasionally weep small amounts of oil as the seals and joints settle in – where this occurs it can be cured by re-tightening the connection – refer to torque settings chart below. The tasks stated above should be performed on an hourly basis during the first day of work and at least daily thereafter as part of the machines general maintenance procedure.

**CAUTION: DO NOT OVER TORQUE HYDRAULIC FITTINGS AND HOSES**

### TORQUE SETTINGS FOR HYDRAULIC FITTINGS

HYDRAULIC HOSE ENDS		
BSP	Setting	Metric
1/4"	18 Nm	19 mm
3/8"	31 Nm	22 mm
1/2"	49 Nm	27 mm
5/8"	60 Nm	30 mm
3/4"	80 Nm	32 mm
1"	125 Nm	41 mm
1.1/4"	190 Nm	50 mm
1.1/2"	250 Nm	55 mm
2"	420 Nm	70 mm

PORT ADAPTORS WITH BONDED SEALS		
BSP	Setting	Metric
1/4"	34 Nm	19 mm
3/8"	47 Nm	22 mm
1/2"	102 Nm	27 mm
5/8"	122 Nm	30 mm
3/4"	149 Nm	32 mm
1"	203 Nm	41 mm
1.1/4"	305 Nm	50 mm
1.1/2"	305 Nm	55 mm
2"	400 Nm	70 mm

# WARRANTY POLICY

## WARRANTY REGISTRATION

All machines must be registered, by the selling dealer with McConnel Ltd, before delivery to the end user. On receipt of the goods it is the buyer's responsibility to check that the Verification of Warranty Registration in the Operator's Manual has been completed by the selling dealer.

### 1. LIMITED WARRANTIES

1.01. *All mounted machines supplied by McConnel Ltd are warranted to be free from defects in material and workmanship from the date of sale to the original purchaser for a period of 12 months, unless a different period is specified.*

*All Self Propelled Machines supplied by McConnel Ltd are warranted to be free from defects in material and workmanship from the date of sale to the original purchaser for a period of 12 months or 1500 hours. Engine warranty will be specific to the Manufacturer of that unit.*

1.02. *All spare parts supplied by McConnel Ltd and purchased by the end user are warranted to be free from defects in material and workmanship from the date of sale to the original purchaser for a period of 6 months. All parts warranty claims must be supported by a copy of the failed part invoice to the end user. We cannot consider claims for which sales invoices are not available.*

1.03. *The warranty offered by McConnel Ltd is limited to the making good by repair or replacement for the purchaser any part or parts found, upon examination at its factory, to be defective under normal use and service due to defects in material or workmanship. Returned parts must be complete and unexamined. Pack the component(s) carefully so that any transit damage is avoided. All ports on hydraulic items should be drained of oil and securely plugged to prevent seepage and foreign body ingress. Certain other components, electrical items for example, may require particular care when packing to avoid damage in transit.*

1.04. *This warranty does not extend to any product from which McConnel Ltd's serial number plate has been removed or altered.*

1.05. *The warranty policy is valid for machines registered in line with the terms and conditions detailed and on the basis that the machines do not extend a period of 24 months or greater since their original purchase date, that is the original invoice date from McConnel Limited.*

*Machines that are held in stock for more than 24 months cannot be registered for warranty.*

1.06. *This warranty does not apply to any part of the goods, which has been subjected to improper or abnormal use, negligence, alteration, modification, fitment of non-genuine parts, accident damage, or damage resulting from contact with overhead power lines, damage caused by foreign objects (e.g. stones, iron, material other than vegetation), failure due to lack of maintenance, use of incorrect oil or lubricants, contamination of the oil, or which has served its normal life. This warranty does not apply to any expendable items such as blades, belts, clutch linings, filter elements, flails, flap kits, skids, soil engaging parts, shields, guards, wear pads, pneumatic tyres or tracks.*

1.07. *Temporary repairs and consequential loss - i.e. oil, downtime and associated parts are specifically excluded from the warranty.*

1.08. *Warranty on hoses is limited to 12 months and does not include hoses which have suffered external damage. Only complete hoses may be returned under warranty, any which have been cut or repaired will be rejected.*

1.09. *Machines must be repaired immediately a problem arises. Continued use of the machine after a problem has occurred can result in further component failures, for which McConnel Ltd cannot be held liable, and may have safety implications.*

1.10. *If in exceptional circumstances a non McConnel Ltd part is used to effect a repair, warranty reimbursement will be at no more than McConnel Ltd's standard dealer cost for the genuine part.*

- 1.11. *Except as provided herein, no employee, agent, dealer or other person is authorised to give any warranties of any nature on behalf of McConnell Ltd.*
- 1.12. *For machine warranty periods in excess of 12 months the following additional exclusions shall apply:*
  - 1.12.1. *Hoses, exposed pipes and hydraulic tank breathers.*
  - 1.12.2. *Filters.*
  - 1.12.3. *Rubber mountings.*
  - 1.12.4. *External electric wiring.*
  - 1.12.5. *Bearings and seals*
  - 1.12.6. *External Cables, Linkages*
  - 1.12.7. *Loose/Corroded Connections, Light Units, LED's*
  - 1.12.8. *Comfort items such as Operator Seat, Ventilation, Audio Equipment*
- 1.13. *All service work, particularly filter changes, must be carried out in accordance with the manufacturer's service schedule. Failure to comply will invalidate the warranty. In the event of a claim, proof of the service work being carried out may be required.*
- 1.14. *Repeat or additional repairs resulting from incorrect diagnosis or poor quality previous repair work are excluded from warranty.*

***NB Warranty cover will be invalid if any non-genuine parts have been fitted or used. Use of non-genuine parts may seriously affect the machine's performance and safety. McConnell Ltd cannot be held responsible for any failures or safety implications that arise due to the use of non-genuine parts.***

## **2. REMEDIES AND PROCEDURES**

- 2.01. *The warranty is not effective unless the Selling Dealer registers the machine, via the McConnell web site and confirms the registration to the purchaser by completing the confirmation form in the operator's manual.*
- 2.02. *Any fault must be reported to an authorised McConnell Ltd dealer as soon as it occurs. Continued use of a machine, after a fault has occurred, can result in further component failure for which McConnell Ltd cannot be held liable.*
- 2.03. *Repairs should be undertaken within two days of the failure. Claims submitted for repairs undertaken more than 2 weeks after a failure has occurred, or 2 days after the parts were supplied will be rejected, unless the delay has been authorised by McConnell Ltd. Please note that failure by the customer to release the machine for repair will not be accepted as a reason for delay in repair or submitting warranty claims.*
- 2.04. *All claims must be submitted, by an authorised McConnell Ltd Service Dealer, within 30 days of the date of repair.*
- 2.05. *Following examination of the claim and parts, McConnell Ltd will pay, at their discretion, for any valid claim the invoiced cost of any parts supplied by McConnell Ltd and appropriate labour and mileage allowances if applicable.*
- 2.06. *The submission of a claim is not a guarantee of payment.*
- 2.07. *Any decision reached by McConnell Ltd. is final.*

## **3. LIMITATION OF LIABILITY**

- 3.01. *McConnell Ltd disclaims any express (except as set forth herein) and implied warranties with respect to the goods including, but not limited to, merchantability and fitness for a particular purpose.*
- 3.02. *McConnell Ltd makes no warranty as to the design, capability, capacity or suitability for use of the goods.*
- 3.03. *Except as provided herein, McConnell Ltd shall have no liability or responsibility to the purchaser or any other person or entity with respect to any liability, loss, or damage caused or alleged to be caused directly or indirectly by the goods including, but not limited to, any indirect, special, consequential, or incidental damages resulting from the use or operation of the goods or any breach of this warranty. Notwithstanding the above limitations and warranties, the manufacturer's liability hereunder for damages incurred by the purchaser or others shall not exceed the price of the goods.*
- 3.04. *No action arising out of any claimed breach of this warranty or transactions under this warranty may be brought more than one (1) year after the cause of the action has occurred.*

#### **4. MISCELLANEOUS**

- 4.01. McConnel Ltd may waive compliance with any of the terms of this limited warranty, but no waiver of any terms shall be deemed to be a waiver of any other term.*
- 4.02. If any provision of this limited warranty shall violate any applicable law and is held to be unenforceable, then the invalidity of such provision shall not invalidate any other provisions herein.*
- 4.03. Applicable law may provide rights and benefits to the purchaser in addition to those provided herein.*

---

*McConnel Limited*





# DECLARATION OF CONFORMITY

*Conforming to EU Machinery Directive 2006/42/EC*

We,

**McCONNEL LIMITED**, Temeside Works, Ludlow, Shropshire SY8 1JL, UK

*Hereby declare that:*

The Product; *Tractor Mounted Hedgecutter / Grass Mower*

Product Code; *T480*

Serial No. & Date ..... Type .....

Manufactured in; *United Kingdom*

Complies with the required provisions of the Machinery Directive 2006/42/EC  
The machinery directive is supported by the following harmonized standards;

- BS EN ISO 12100 (2010) Safety of machinery – General principles for design – Risk assessment and risk reduction.
- BS EN 349 (1993) + A1 (2008) Safety of machinery - Minimum distances to avoid the entrapment with human body parts.
- BS EN ISO 14120 (2015) Safety of machinery - Guards general requirements for the design and construction of fixed and movable guards.
- BS EN 4413 (2010) Hydraulic fluid power. Safety requirements for systems and their components.

McCONNEL LIMITED operates an ISO 9001:2008 quality management system, certificate number: FM25970.

This system is continually assessed by the;

British Standards Institution (BSI), Beech House, Milton Keynes, MK14 6ES, UK  
BSI is accredited by UK Accreditation Service, accreditation number: UKAS 003.  
The EC declaration only applies if the machine stated above is used in accordance with the operating instructions.

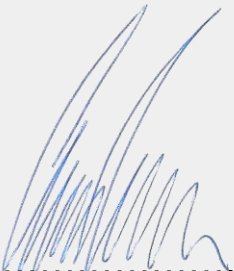
Signed  ..... *Responsible Person*  
*CHRISTIAN DAVIES on behalf of McCONNEL LIMITED*

Status: *General Manager*

Date: *January 2018*



# DECLARATION OF CONFORMITY

*Conforming to EU Machinery Directive 2006/42/EC*

We,

**McCONNEL LIMITED**, Temeside Works, Ludlow, Shropshire SY8 1JL, UK

*Hereby declare that:*

The Product; *Hydraulic Arm Mounted Flail Head*

Product Code; *TWHD*

Serial No. & Date ..... Type .....

Manufactured in; *United Kingdom*

Complies with the required provisions of the Machinery Directive 2006/42/EC  
The machinery directive is supported by the following harmonized standards;

- BS EN ISO 12100 (2010) Safety of machinery – General principles for design – Risk assessment and risk reduction.
- BS EN 349 (1993) + A1 (2008) Safety of machinery - Minimum distances to avoid the entrapment with human body parts.
- BS EN ISO 14120 (2015) Safety of machinery - Guards general requirements for the design and construction of fixed and movable guards.
- BS EN 4413 (2010) Hydraulic fluid power. Safety requirements for systems and their components.

McCONNEL LIMITED operates an ISO 9001:2008 quality management system, certificate number: FM25970.

This system is continually assessed by the;

British Standards Institution (BSI), Beech House, Milton Keynes, MK14 6ES, UK

BSI is accredited by UK Accreditation Service, accreditation number: UKAS 003.

The EC declaration only applies if the machine stated above is used in accordance with the operating instructions.

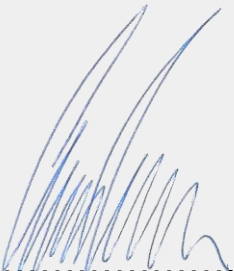
Signed  ..... *Responsible Person*  
*CHRISTIAN DAVIES on behalf of McCONNEL LIMITED*

Status: *General Manager*

Date: *January 2018*





# LIST OF CONTENTS

---

	<i>Page No.</i>
General Information	1
Specifications & Features	2
Safety Information	3
Introduction	8
Tractor Selection	9
Hydraulic Oil	11
Machine Attachment	12
Head Motor Hose Installation	16
Operation Information	17
Rotor Rotation Direction	18
Rotor Control	18
Cable Controls – <i>Levers and Symbols</i>	19
Cable Controls – <i>Lever Functions</i>	20
Hydraulic Controls – <i>Cutting Position</i>	21
Cutting Head	21
Transportation	22
Cutting Head Belt Adjustment	23
Cutting Head Belt Replacement	24
Rotor Removal & Replacement	25
Roller Height Adjustment	26
Machine Removal	27
Maintenance	28



# GENERAL INFORMATION

Read this manual before fitting or operating the machine. Whenever any doubt exists contact your dealer or the McConnel Service Department for assistance.

**Use only Twose Classic Line Parts on Twose Classic Line equipment and machines.**

DEFINITIONS - The following definitions apply throughout this manual:

**WARNING:**  
An operating procedure, technique etc., which can result in personal injury or loss of life if not observed carefully.

**CAUTION:**  
An operating procedure, technique etc., which can result in the damage of either machine or equipment if not observed carefully.

**NOTE:**  
An operating procedure, technique etc., which is considered essential to emphasise.

**LEFT AND RIGHT HAND:**  
This term is applicable to the machine when fitted to the tractor and viewed from the rear. This also applies to tractor references.

**Note:** The illustrations in this manual are for instructional purposes only and may on occasion not show some components in their entirety. In some instances an illustration may appear slightly different to that of your particular model but the general procedure will be the same. E&OE.

## MACHINE & DEALER INFORMATION

<i>Record the Serial Number of your machine on this page and always quote this number when ordering parts. Whenever information concerning the machine is requested remember also to state the make and model of tractor to which the machine is fitted.</i>	
Machine Serial Number:	Installation Date:
Machine Model details:	
Dealer Name:	
Dealer Address:	
Dealer Telephone No:	
Dealer Email Address:	

### Noise

*The equivalent daily personal noise exposure from this machine, measured at the operators' ear, is within the range 78 – 85 dB.*

*These figures apply to a normal distribution of use where the noise fluctuates between zero and maximum. The figures assume that the machine is fitted to a tractor with a quiet cab with the windows closed in a generally open environment. We recommend that the windows are kept closed.*

*With the cab rear window open the equivalent daily personal noise exposure will increase to a figure within the range 82 – 88 dB.*

*At equivalent daily noise exposure levels of between 85 and 90 dB, ear protection is recommended; it should be used at all times if any window is left open.*

# **SPECIFICATIONS & FEATURES**

---

## **TW 52-2 Model**

- 5.20m (17ft 0in) Reach
- Left Hand or Right Hand Build
- 1.2m HD Flailhead (Belt Drive)
- Slide Mount Flailhead
- Totally Independent Hydraulics
- 3-Point Linkage Mounted (Cat II)
- 200 litre Hydraulic Reservoir
- 240° Head Rotation
- Cast Iron Pumps & 45HP Motor
- Cable Controls
- Mechanical Safety Breakback
- Head Float
- Dual Direction Flail Rotation
- Cab Safety Guard Kit

## **Options**

- Arm Float Kit
- Flailhead Skids



# **SAFETY INFORMATION**

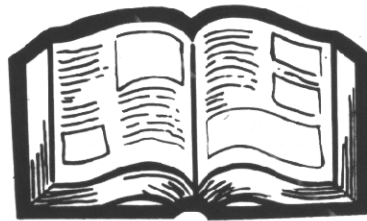

## **SAFETY INFORMATION**

---

This machine has the potential to be extremely dangerous, in the wrong hands it can kill or maim. It is therefore imperative that the owner, and the operator of this machine, read the following section to ensure that they are both fully aware of the dangers that do, or may exist, and their responsibilities surrounding its use.

The operator of this machine is responsible not only for their own safety but equally for the safety of others who may come into the close proximity of the machine, as the owner you are responsible for both.

### **POTENTIAL SIGNIFICANT DANGERS ASSOCIATED WITH THE USE OF THIS MACHINE:**

- ▲ *Being hit by debris thrown by rotating components.*
- ▲ *Being hit by machine parts ejected through damage during use.*
- ▲ *Being caught on a rotating power take-off (PTO) shaft.*
- ▲ *Being caught in other moving parts i.e.: belts, pulleys and cutting heads.*
- ▲ *Electrocution from Overhead Power Lines (by contact with or 'flashover' from).*
- ▲ *Being hit by cutting heads or machine arms as they move.*
- ▲ *Becoming trapped between tractor and machine when hitching or unhitching.*
- ▲ *Tractor overbalancing when machine arm is extended.*
- ▲ *Injection of high pressure oil from hydraulic hoses or couplings.*
- ▲ *Machine overbalancing when freestanding (out of use).*
- ▲ *Road traffic accidents due to collision or debris on the road.*

### **BEFORE USING THIS MACHINE YOU MUST:**

- ▲ *Ensure you read all sections of the operator handbook.*
- ▲ *Ensure the operator is, or has been, properly trained to use the machine.*
- ▲ *Ensure the operator has been issued with and reads the operator handbook.*
- ▲ *Ensure the operator understands and follows the instructions in operator handbook.*
- ▲ *Ensure the tractor front, rear and side(s) are fitted with metal mesh or polycarbonate guards of suitable size and strength to protect the operator against thrown debris or parts.*

- ▲ *Ensure tractor guards are fitted correctly, are undamaged and kept properly maintained.*
- ▲ *Ensure that all machine guards are in position, are undamaged, and are kept maintained in accordance with the manufacturer's recommendations.*
- ▲ *Ensure flails and their fixings are of a type recommended by the manufacturer, are securely attached and that none are missing or damaged.*
- ▲ *Ensure hydraulic pipes are carefully and correctly routed to avoid damage by chaffing, stretching or pinching and that they are held in place with the correct fittings.*
- ▲ *Always follow the manufacturer's instructions for attachment and removal of the machine from the tractor.*
- ▲ *Check that the machine fittings and couplings are in good condition.*
- ▲ *Ensure the tractor meets the minimum weight recommendations of the machine manufacturer and that ballast is used as necessary.*
- ▲ *Always inspect the work area thoroughly before starting to note obstacles and remove wire, bottles, cans and other debris.*
- ▲ *Use clear suitably sized warning signs to alert others to the nature of the machine working within that area. Signs should be placed at both ends of the work site. (It is recommended that signs used are of a size and type specified by the Department of Transport and positioned in accordance with their and the Local Highways Authority guidelines).*
- ▲ *Ensure the operator is protected from noise. Ear defenders should be worn and tractor cab doors and windows must be kept closed. Machine controls should be routed through proprietary openings in the cab to enable all windows to be shut fully.*
- ▲ *Always work at a safe speed taking account of the conditions i.e.: terrain, highway proximity and obstacles around and above the machine.*
- ▲ *Extra special attention should be applied to Overhead Power Lines. Some of our machines are capable of reach in excess of 8 metres (26 feet) this means they have the potential to well exceed, by possibly 3 metres (9' 9"), the lowest legal minimum height of 5.2 metres from the ground for 11,000 and 33,000 volt power lines. It cannot be stressed enough the dangers that surround this capability, it is therefore vital that the operator is fully aware of the maximum height and reach of the machine, and that they are fully conversant with all aspects regarding the safe minimum distances that apply when working with machines in close proximity to Power Lines. (Further information on this subject can be obtained from the Health & Safety Executive or your Local Power Company).*



- ▲ *Always disengage the machine, kill the tractor engine, remove and pocket the key before dismounting for any reason.*
- ▲ *Always clear up all debris left at the work area, it may cause hazard to others.*
- ▲ *Always ensure when you remove your machine from the tractor that it is left in a safe and stable position using the stands and props provided and secured if necessary.*

#### **WHEN NOT TO USE THIS MACHINE:**

- ▲ *Never attempt to use this machine if you have not been trained to do so.*
- ▲ *Never uses a machine until you have read and understood the operator handbook, are familiar with, and practiced the controls.*
- ▲ *Never use a machine that is poorly maintained.*
- ▲ *Never use a machine if guards are missing or damaged.*
- ▲ *Never use a machine on which the hydraulic system shows signs of wear or damage.*
- ▲ *Never fit, or use, a machine on a tractor that does not meet the manufacturer's minimum specification level.*
- ▲ *Never use a machine fitted to a tractor that does not have suitable front, rear and side(s) cab guarding made of metal mesh or polycarbonate.*
- ▲ *Never use the machine if the tractor cab guarding is damaged, deteriorating or badly fitted.*
- ▲ *Never turn a machine cutting head to an angle that causes debris to be ejected towards the cab.*
- ▲ *Never start or continue to work a machine if people are nearby or approaching - Stop and wait until they are at a safe distance before continuing.*
- ▲ *Never attempt to use a machine on materials in excess of its capability.*
- ▲ *Never use a machine to perform a task it has not been designed to do.*
- ▲ *Never operate the tractor or machine controls from any position other than from the driving seat, especially whilst hitching or unhitching the machine.*
- ▲ *Never carry out maintenance of a machine or a tractor whilst the engine is running – the engine should be switched off, the key removed and pocketed.*
- ▲ *Never leave a machine unattended in a raised position – it should be lowered to the ground in a safe position on a level firm site.*

- ▲ *Never leave a tractor with the key in or the engine running.*
- ▲ *Never carry out maintenance on any part or component of a machine that is raised unless that part or component has been properly substantially braced or supported.*
- ▲ *Never attempt to detect a hydraulic leak with your hand – use a piece of cardboard.*
- ▲ *Never allow children near to, or play on, a tractor or machine under any circumstances.*

---

**Although the information given here covers a wide range of safety subjects, it is impossible to predict every eventuality that can occur under differing circumstances whilst operating a machine of this type. No advice given here can replace ‘good common sense’ and ‘total awareness’ at all times, but will go a long way towards the safe use of your Twose machine.**

---

# INTRODUCTION

---

Two Series Boom Flail Trimmers have been designed with both the farmer and the contractor in mind; this has resulted in a boom flail with high specification and many features that are not found on other machines.

The construction is of welded steel fabricated assemblies - with many and varied options available covering such things as controls, hydraulics, heads, booms etc. The cutting head is of a 'double skin' construction.

The cutting flail blades offered for your Two Series machines are: -

- a) Heavy, double edged design (one piece).
  - For 'Upward' or 'Downward' cutting.
  - Suitable for all types of conditions and growth.

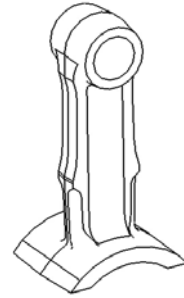

- b) Back to Back 'rigid' one piece blade (in pairs).
  - For 'Upward' or 'Downward' cutting.
  - Suitable for grass/mowing and trimming.

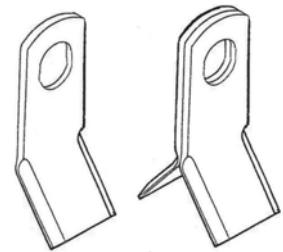
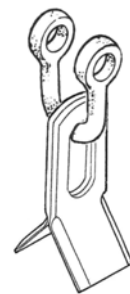

*Illustration shows both a single blade and pair of blades back to back.*

- c) Heavy single edge blade flail (twisted pattern).
  - Cuts one direction only.
  - For grass cutting and hedge trimming.



- d) Back to Back - on shackle (in pairs).
  - For 'Upward' or 'Downward' cutting.
  - Suitable for grass/mowing.



- e) Boot flail - on shackle.
  - Cuts one direction only.
  - For grass cutting and hedge trimming.



The cutter head design is of a 'double skin' construction for greater strength and longer life. The drive is by means of 'vee' belts from the hydraulic motor to the rotor, with the drive completely contained within the width of head for a cleaner cut.

Twin 'vee' belts take the drive from the motor to the rotor - giving a reliable drive with the added benefit of anti-shock protection that a belt drive system provides.

A 'swing link breakback' system is built into the machine; this offers a degree of protection to machine components if an obstruction is encountered during normal work.

Two parking stand legs are fitted to the machine, which once the machine has been attached to the tractor should be folded away in the 'stow' position.

The machine has 'angle head flotation' as standard –this is engaged by moving the head rotation lever beyond the normal actuation range into a detented 'float' position. 'Lift float' is available as an option on the machine.

All machines have a relief valve in the primary ram system, this limits the pressure which can be generated in the drop side of the cylinder – the cutting head cannot therefore be 'driven' into the ground in any circumstances.

## TRACTOR SELECTION

---

### Tractor Specifications

TW 52-2 Model – Tractor size must be a minimum of 45kW (60 HP) – 2250kg

Tractors must be equipped with a power take off (PTO) shaft that must run at 450 rpm during operation. The PTO shaft should run clockwise when viewed from the rear of the tractor and ideally be of a 1 $\frac{3}{8}$ ” S.A.E. – 6 spline shaft type to enable a standard PTO shaft to be connected.

The tractor should have counterbalance weights (*on approved mountings*) fitted if necessary and/or ballasted wheels to ensure stability of the unit at all times.

Stability may be further increased with a wider track setting on the tractors rear wheels – *contact your local dealer or tractor agent for specific advice on this subject.*

Four wheel drive tractors have extra weight inbuilt plus larger front wheels, this is an advantage in keeping the unit stable.

## TRACTOR/OPERATOR GUARDING

---

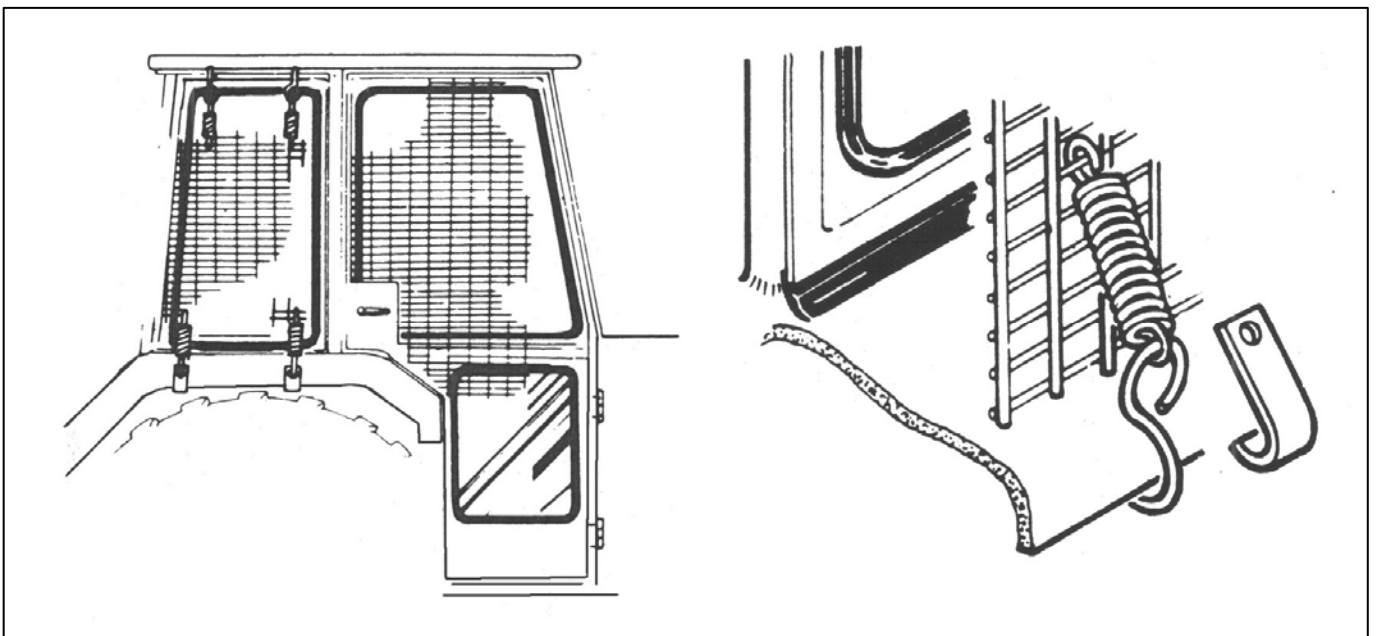

Use a tractor with ‘safety glass’ windows if possible and fit **Operator guard** (*Part No.7313324*) using the hooks provided.

Shape ‘safety protection material’ to cover all vulnerable areas. Remember the driver must be looking through ‘safety protection’ at the flail head in any working position.

If the windows are not laminated safety glass polycarbonate glazing must also be fitted.

If the tractor has a roll bar only, a frame must be made to carry both mesh and polycarbonate glazing.

Ensure the operator is guarded by ‘safety protection’ whatever position the machine is in and that the protection is such that it does not interfere with tractor and machine functions or obstruct the operator’s vision.

## HYDRAULIC OIL

---

### IMPORTANT

The hydraulic system will have been 'run-up' and checked at the factory prior to the machines despatch, where 'Texaco Rando 46' hydraulic oil is used - and is recommended for the machine.

The hydraulic tank will have oil in it when delivered.

Oil tank capacity for the TW 52-2 is 200 Litres

The user must ensure the hydraulic tank is full of 'RANDO 46' hydraulic oil (or an equivalent recommended oil – refer to oil chart below) before attempting to start the machine from new.

### Recommended Oils

<b>Manufacturer</b>	<b>Cold or Temperate Climate</b>	<b>Hot Climate</b>
<b>BP</b>	<i>Bartran 46</i> <i>Energol HLP-HM 46</i>	<i>Bartran 68</i> <i>Energol HLP-HM 68</i>
<b>CASTROL</b>	<i>Hyspin AWH-M 46</i>	<i>Hyspin AWH-M 68</i>
<b>COMMA</b>	<i>Hydraulic Oil LIC 15</i>	<i>Hydraulic Oil LIC 20</i>
<b>ELF</b>	<i>Hydrelf HV 46</i> <i>Hydrelf XV 46</i>	<i>Hydrelf HV 68</i>
<b>ESSO</b>	<i>Univis N 46</i>	<i>Univis N 68</i>
<b>FUCHS</b> (UK/Non UK markets*)	<i>Renolin 46</i> <i>Renolin HVZ 46</i> <i>Renolin CL46/B15*</i> <i>Renolin AF46/ZAF46B*</i>	<i>Renolin 68</i> <i>Renolin HVZ 68</i> <i>Renolin CL68/B20*</i> <i>Renolin AF68/ZAF68B*</i>
<b>GREENWAY</b>	<i>Excelpower HY 68</i>	<i>Excelpower HY 68</i>
<b>MILLERS</b>	<i>Millmax 46</i> <i>Millmax HV 46</i>	<i>Millmax 68</i> <i>Millmax HV 68</i>
<b>MORRIS</b>	<i>Liquimatic 5</i> <i>Liquimatic HV 46</i> <i>Triad 46</i>	<i>Liquimatic 6</i> <i>Liquimatic HV 68</i> <i>Triad 68</i>
<b>SHELL</b>	<i>Tellus 46</i> <i>Tellus T46</i>	<i>Tellus 68</i> <i>Tellus T68</i>
<b>TEXACO</b>	<i>RandoHD 46</i> <i>Rando HDZ 46</i>	<i>Rando HD 68</i> <i>Rando HDZ 68</i>
<b>TOTAL</b>	<i>Equivis ZS 46</i>	<i>Equivis ZS 68</i>

The tank top filter/breather is equipped with a strainer to ensure all oil is strained when being put into tank. The strainer basket - should never be removed, all hydraulic oil filling is to be done through the strainer.

### WARNING

Never mix hydraulic oils - if another supplier's oil is to be used ensure it is suitably compatible oil - *Check with your oil supplier or machine manufacturer first.*

## ATTACHING THE MACHINE

---

### IMPORTANT: -

Attachment of the machine to the tractor should always be performed on a firm level site.

- Remove locking pins and lift pins supplied with Hedge trimmer from lower link positions of linkage frame.
- Slowly and very carefully reverse the tractor towards the machine linkage frame.
- With care - ensure that tractor lower link ball eyes fit between lower jaws of linkage frame and that pin holes are aligned.

### SWITCH OFF TRACTOR ENGINE AND ENSURE HANDBRAKE IS ON

- With holes of tractor lower link eyes in line with lower jaw holes of frame - the lower linkage pins should now be refitted – *fit spacers if required to prevent side movement of link arms.*
- Secure lift pins in position using locking pins.
- Fit and secure the stabiliser's top link yoke to the tractor's top link - select the highest available position avoiding any load sensing properties.
- Attach top link to machines top link point.
- Raise the machine on the tractor's linkage to a position where the stub shaft of the tractors PTO drive and the stub shaft of the machine gearbox are horizontally aligned.  
*Note: As lift occurs be aware that the machine may tilt slightly.*
- Tractor lower linkage check chains should now be tightened to ensure tractor arms are locked and machine is positioned centrally to the tractor.
- Adjust top link to bring the machine into the vertical position.
- Check the PTO shaft length.

*When connected from tractor to machine it should engage by 1/3rd of the total shaft length, i.e. male part should be halfway from the end to fully 'bottomed' out. Do not use the machine until this has been cut to the correct length.*

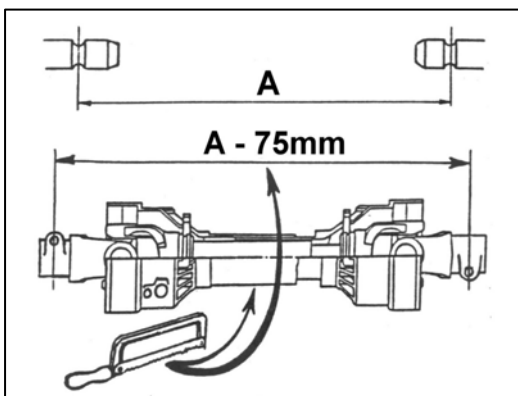

*Measure the PTO shaft and cut to the dimension shown – the finished length of the PTO shaft should be 75mm (3") less than the measured distance 'A' -between tractor shaft and gearbox stub shaft – to enable fitting.*

#### NOTE:

*For subsequent use with different tractors measure again, there must be a minimum shaft overlap of 150mm (6").*

- Fit the PTO shaft.
- Ensure the shaft is correctly fitted to the splines at both ends.
- Fit the anti-spin chains of the PTO guard to a suitable rigid non-turning location.
- Raise stand legs into their stowage position and secure with locking pins.
- Fit mesh safety screens - they are designed to be fitted to the cutting head side of tractor cab (i.e. for left-hand cut machines to left-hand side of cab). Secure in position using the fixings provided ensuring that all exposed glass areas on the cutting side of the tractor are fully protected. **All glass screens on the relevant side of cab must be protected.**
- Fix valve control handles into position:-
- Control levers are supplied bolted together as a complete unit along with a mounting bracket for attachment within the tractor - *the number of controllers in the set can vary dependent on the particular model or specification machine*. The mounting bracket should be positioned on the inner wing face of the tractor cab in a suitable position for ease of operation.

It is suggested that for three and four bank controller sets the bracket is fitted to the left-hand wing for left-hand cut machines and right-hand wing for right-hand cut machines. In the case of electric machines with a single-bank rotor controller is required it is suggested that the bracket is fitted to the opposite side for the control of the cutting direction and that the joystick mounting bracket is fitted to the cutting side - both brackets are however the same.



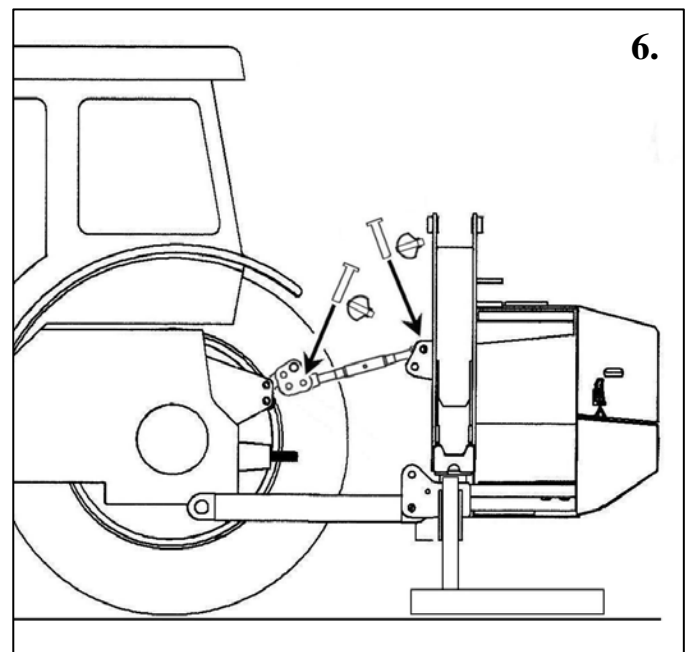
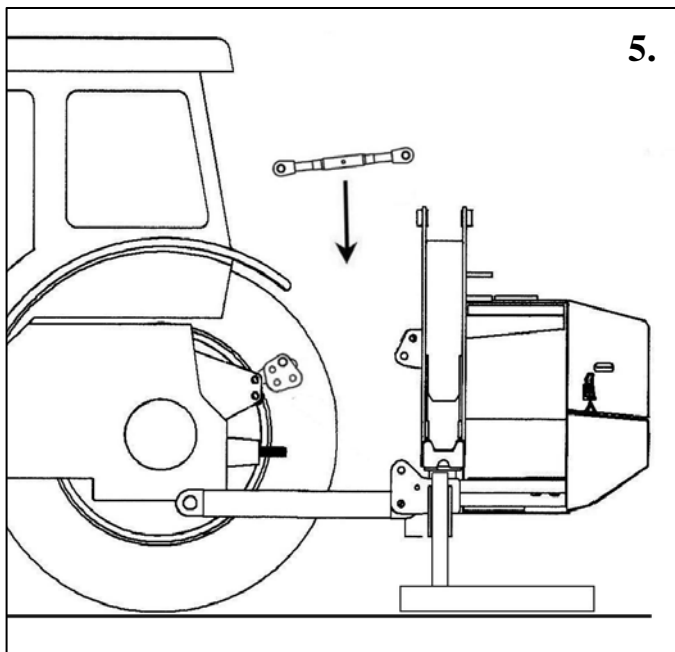
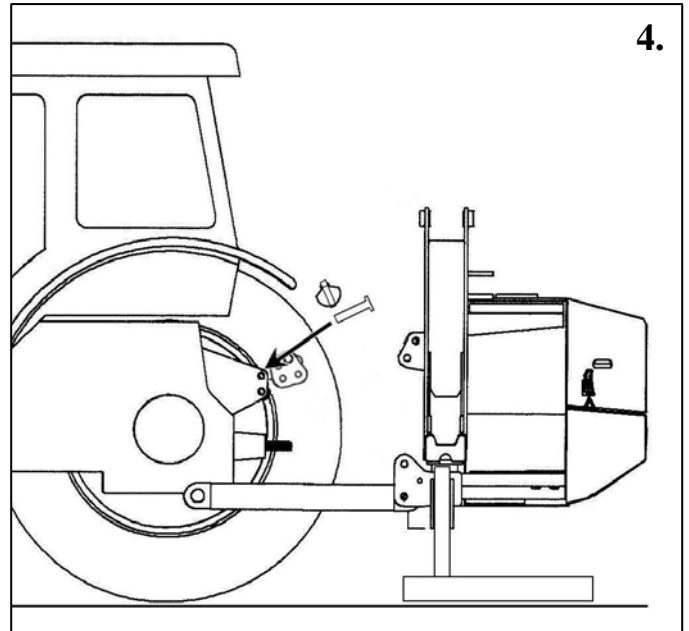
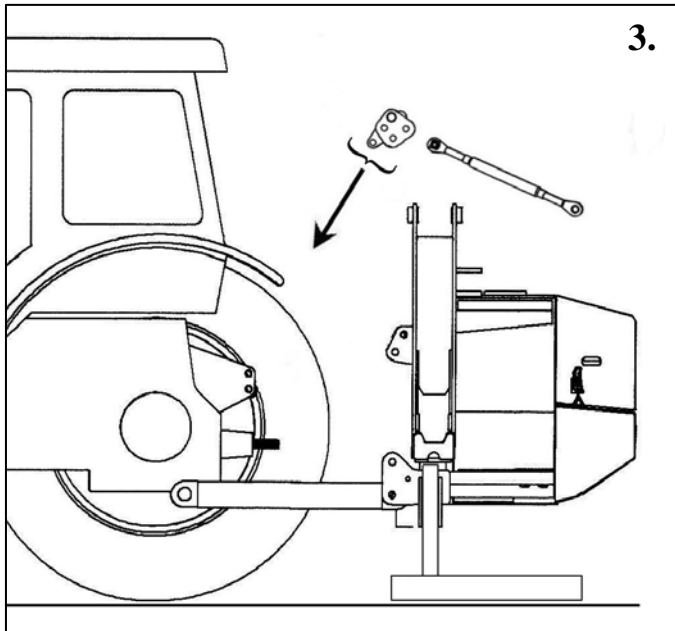
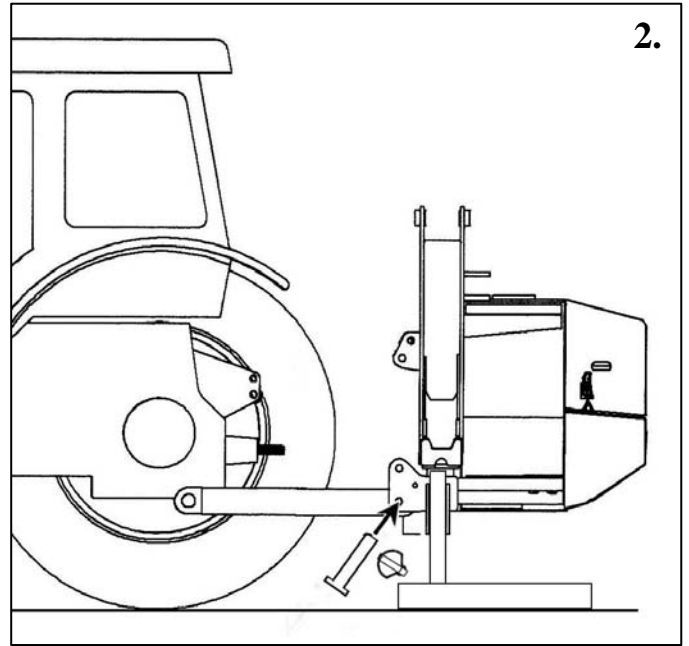
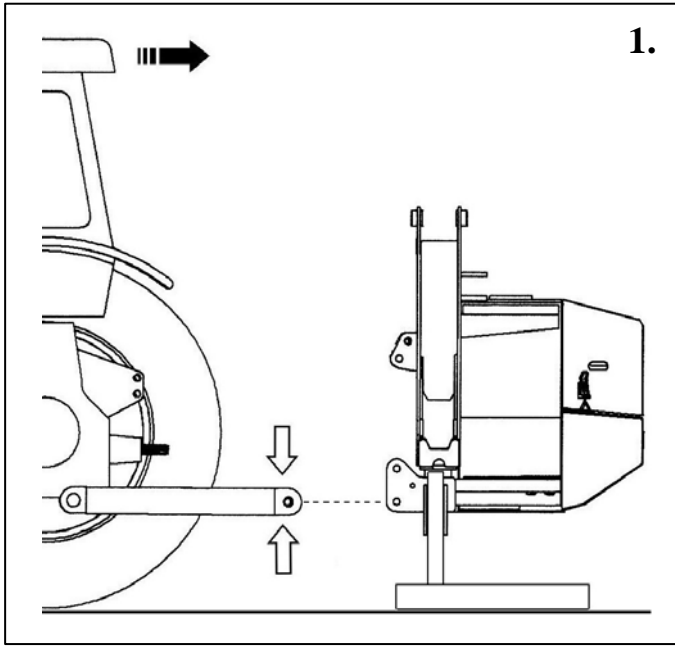

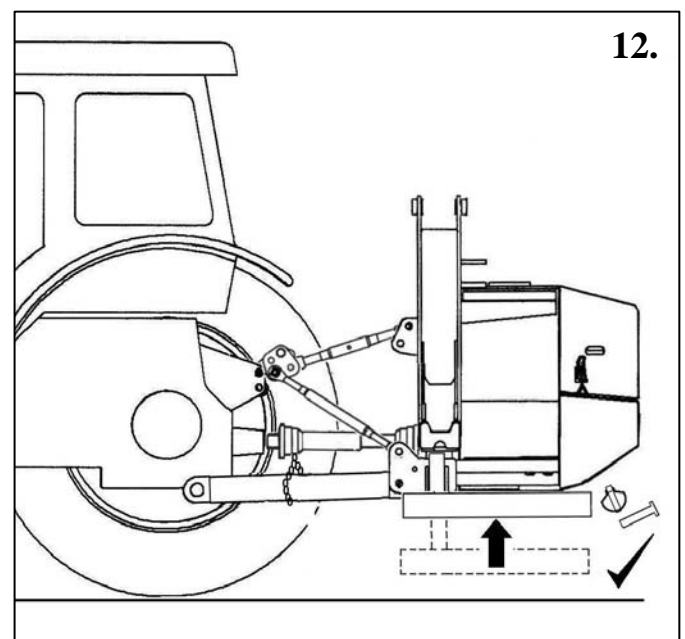
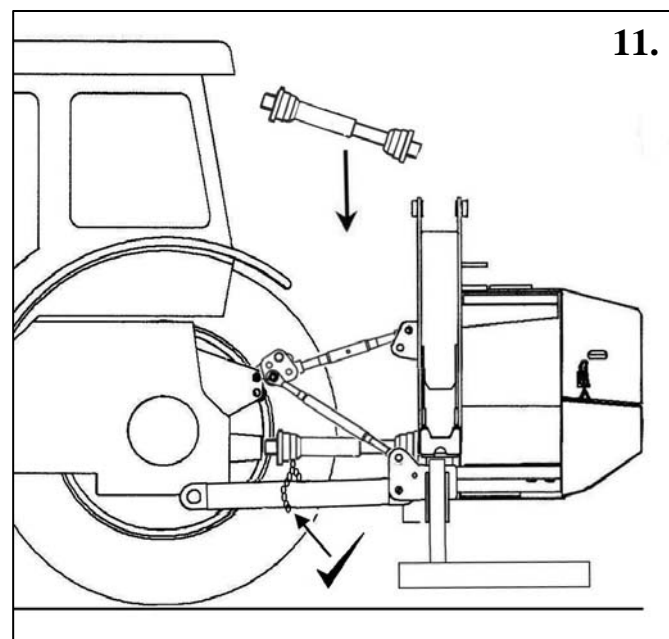
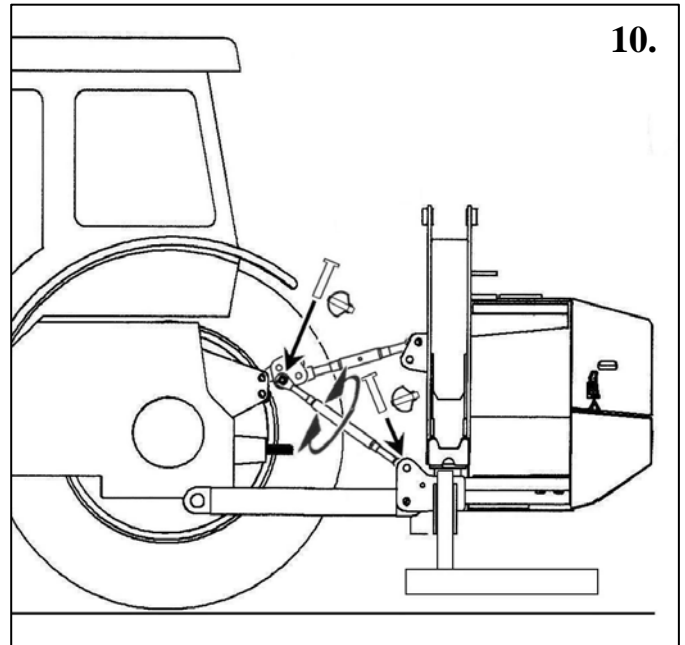
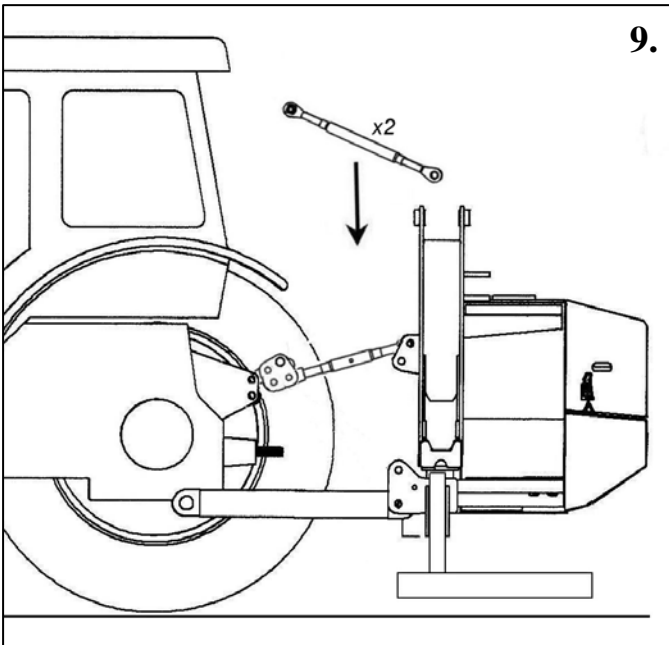
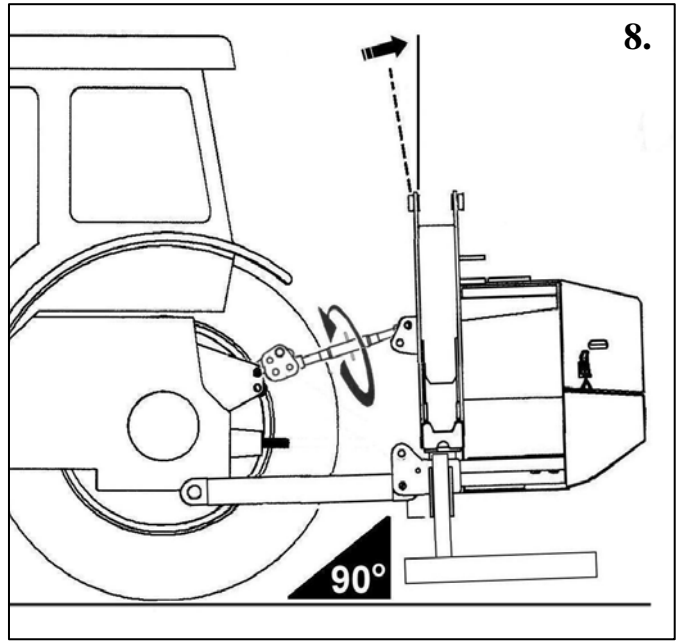
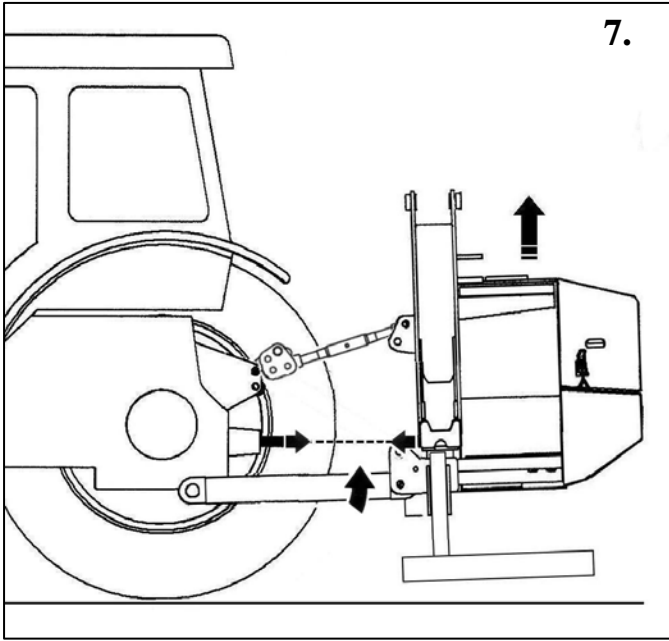

# HEAD MOTOR HOSE INSTALLATION

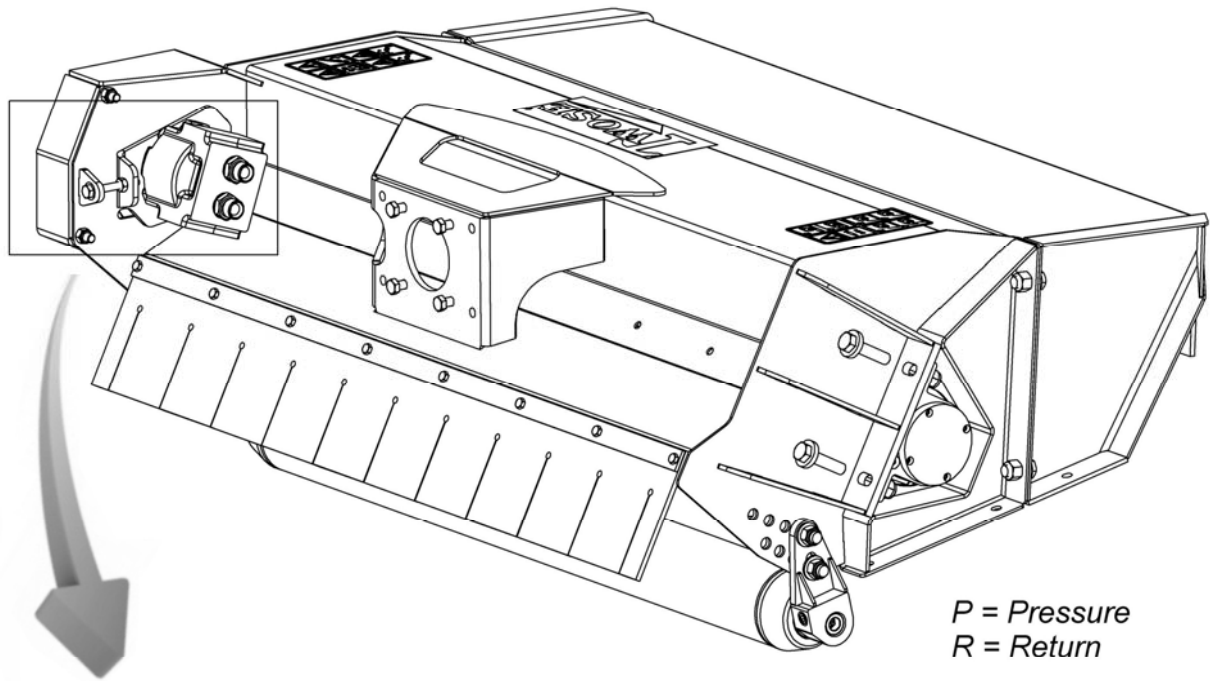

P = Pressure  
R = Return

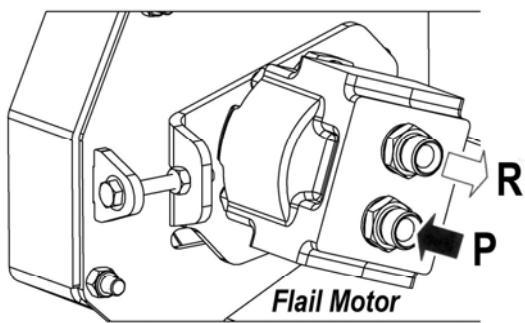

Flail Motor

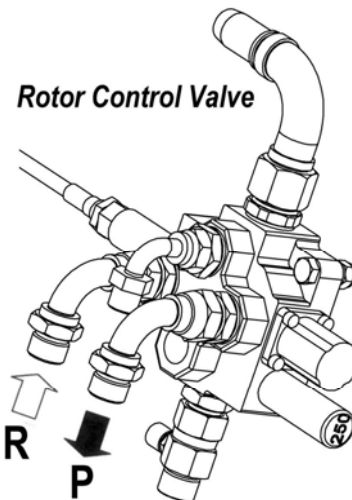

Rotor Control Valve

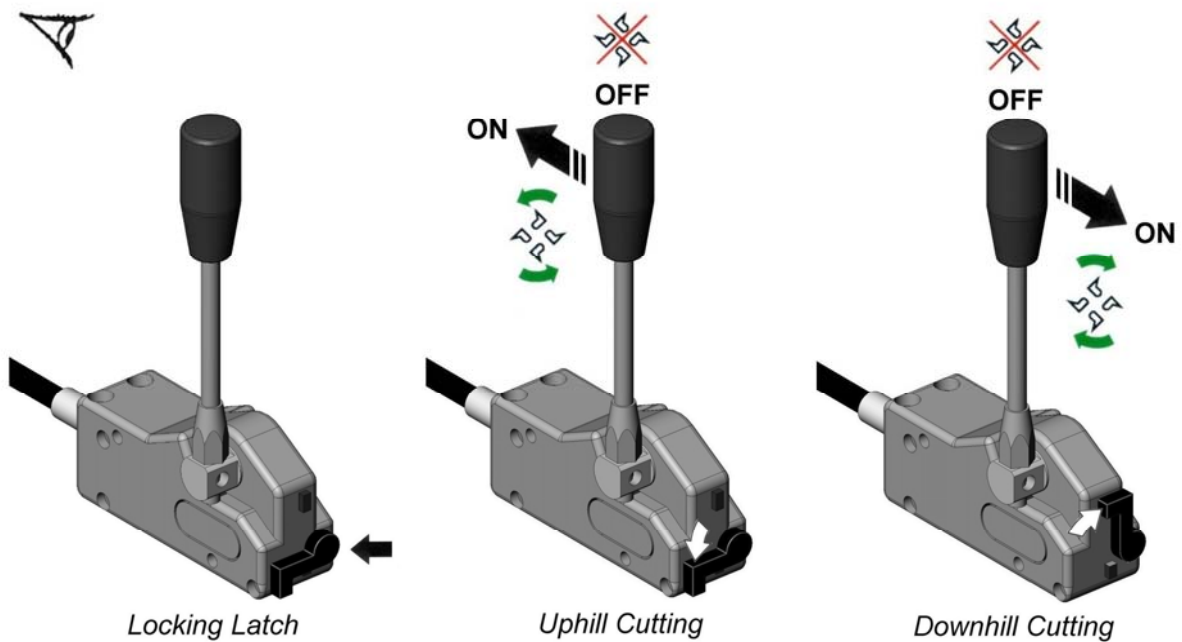

Locking Latch

Uphill Cutting

Downhill Cutting

## FLAIL TRIMMER- OPERATION INFORMATION

The vehicle driver should be conversant with all tractor controls and capabilities.

It is always advisable for the tractor driver to practice the controls and operations of the Flail Trimmer, in a safe open location away from potential hazards, prior to setting off into work.

The speed of operation of Trimming will depend on the size, quantity, and type of growth to be cut. A slow speed to suit conditions should be selected, ensuring that engine speed gives a P.T.O speed of 540 Max. R.P.M for general use - *this 540 Max. R.P.M (PTO) is recommended for best trimming results and performance, variation from this recommended R.P.M should be kept to a minimum and never at any time should PTO R.P.M exceed 540 R.P.M.*

### ROTOR ROTATION DIRECTION

Depending on the type of hedge to be cut, an option of rotation direction is offered.

The 'upward' cut is recommended for trimming grass, light growth such as one/two year's growth.

**DOWNWARD CUTTING IS NOT RECOMMENDED** - and should only be considered for heavier growth (maximum three year growth) - even then, it is important that downward cutting is kept to an absolute minimum and only for short periods.

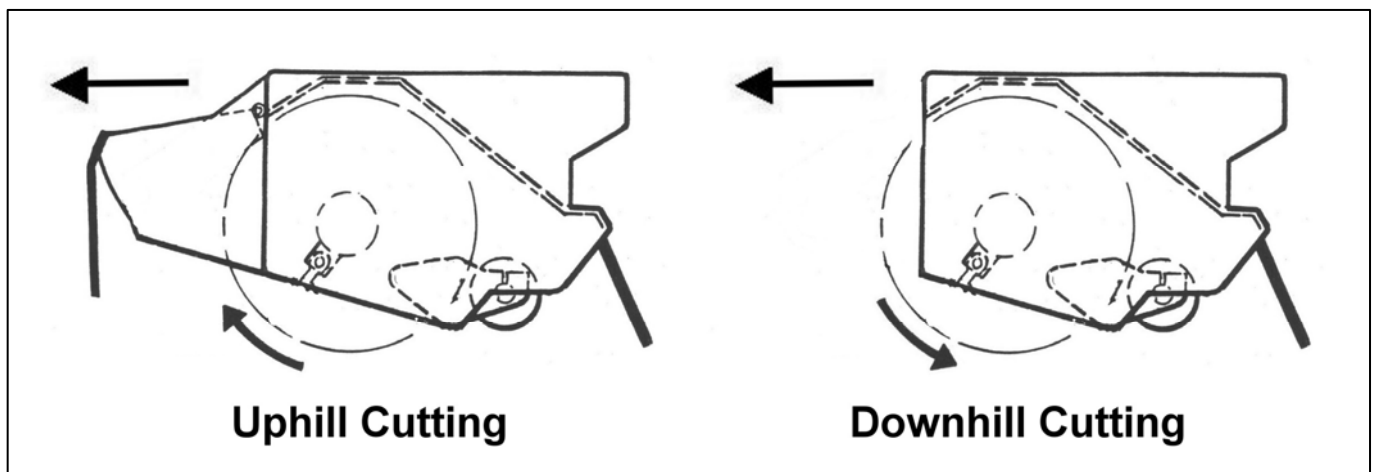

### DANGER - IMPORTANT

In heavy conditions when cutting large diameter growth with front cowling removed, the rotor **MUST ALWAYS CUT DOWNWARDS AT FRONT**. **At no time should the rotor be cutting upwards with the front cowling removed.**

# ROTOR OPERATION

## DANGER VERY IMPORTANT

It is very important that motor spool and motor spool control lever works in one direction only - From centre (OFF) position to selected (ON) 'rotor cut' direction position – permitting the rotor one direction of cut and the 'OFF' setting only. This eliminates the chance of going from 'cut-up' to 'cut-down' in one movement of controls and blowing the system. Only by altering LOCK-LEVER setting can direction of control lever be changed.

## WARNING

**DANGER** - Never change direction of rotor cut whilst rotor is still turning.  
**DANGER** - Always allow rotor to stop spinning completely before changing cut rotation direction.

## ROTOR CONTROL OPERATION

The rotor control lever operates the rotor 'on' and 'off' function for both uphill and downhill cutting - the specific cutting direction is dictated by the position of the locking latch on the front of the cable control head unit, with the latch in the vertical position the lever can be moved from its centre 'off' position to the forwards 'on' position for uphill cutting direction. With the latch in the horizontal position the lever can be moved from its centre 'off' position to the backwards 'on' position for downhill cutting direction. The rotor is off when the control lever is in the central position – *see illustration below.*

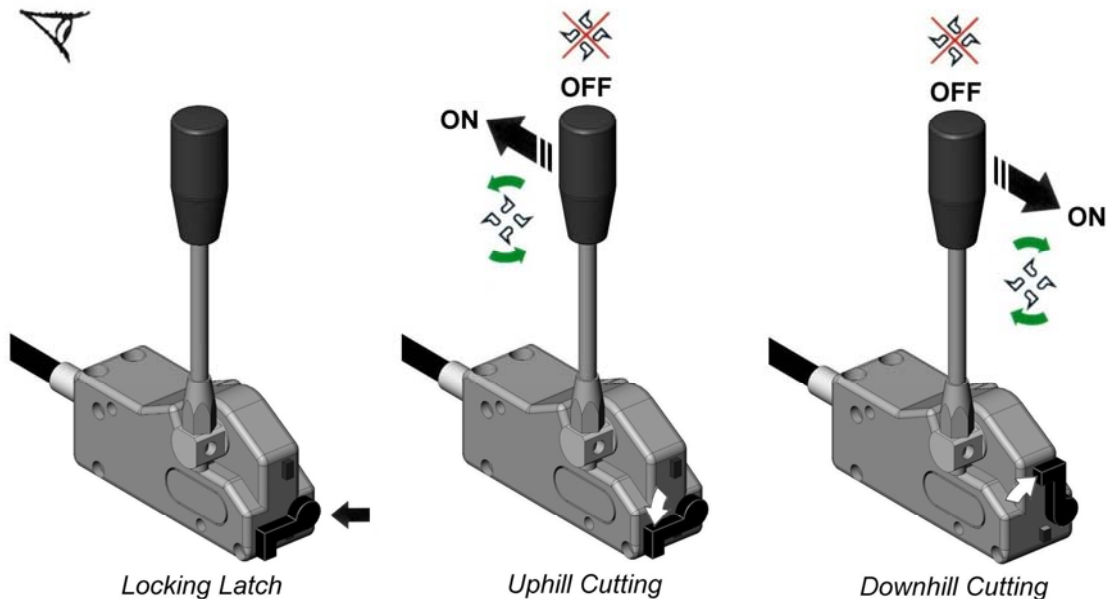

**WARNING:** When switching off a rotor it will continue to 'freewheel' before stopping - in some cases this can be up to 40 seconds or more. Never approach a machine whilst the rotor is running.

## ROTOR CUT DIRECTION MUST NEVER BE CHANGED IN ONE MOVEMENT

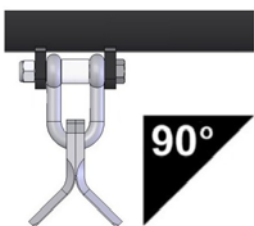

### CAUTION!

For heads with shackle mounted flails, starting and stopping of the rotor should be performed with the head in the horizontal position; this will avoid the risk of outer flails coming into contact with the side casing during rotor 'start-up' and 'slow-down'. Failure to observe this will result in damage to the casing and flails.

# CABLE CONTROLS

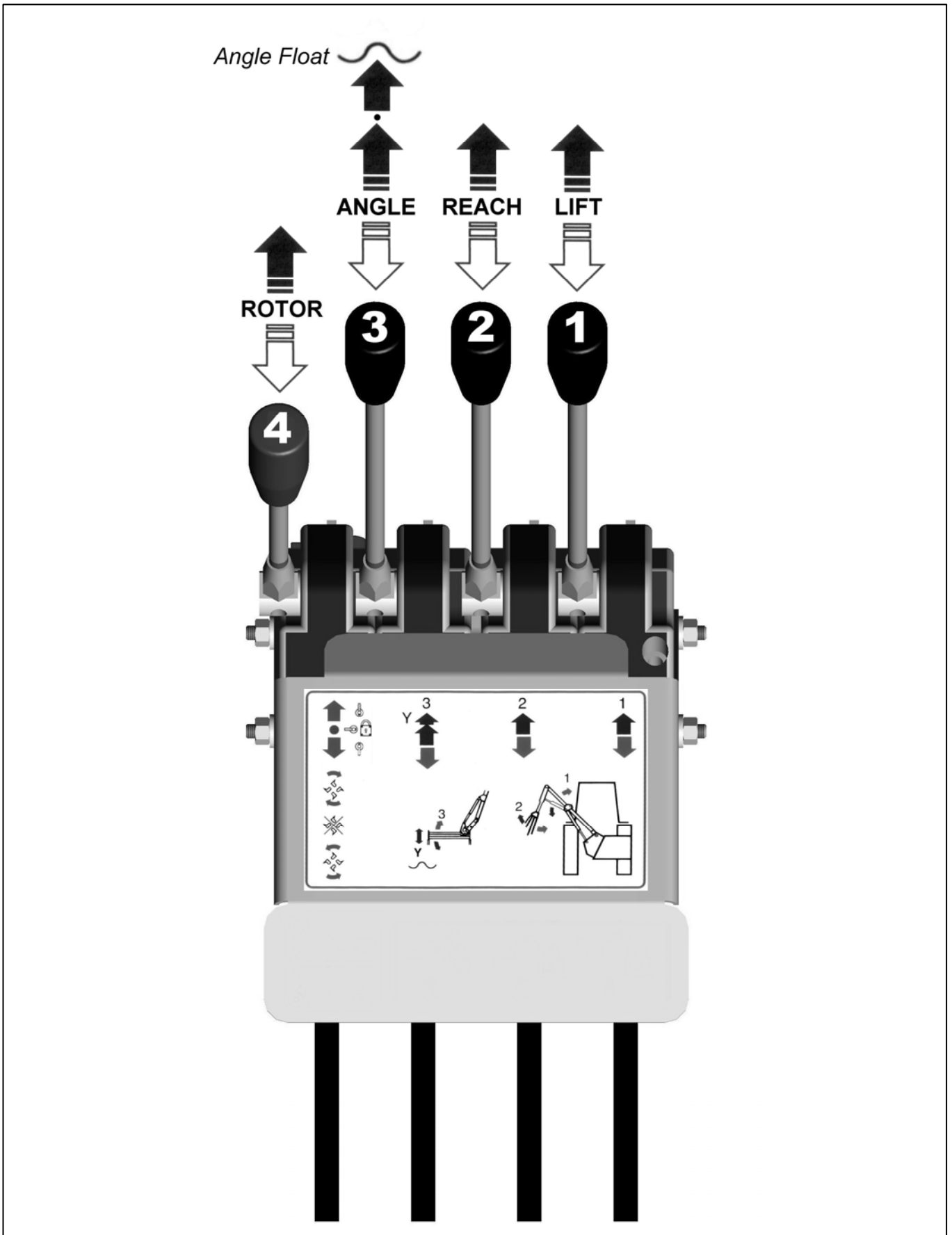

# CABLE CONTROLS – LEVER FUNCTIONS

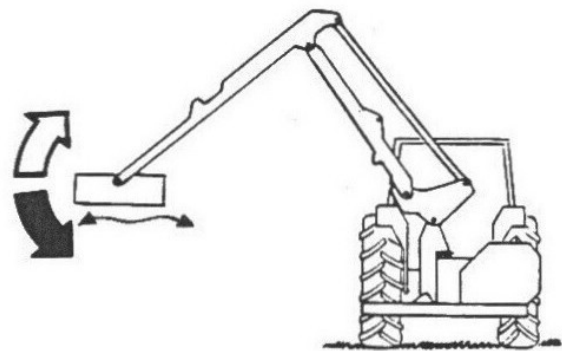
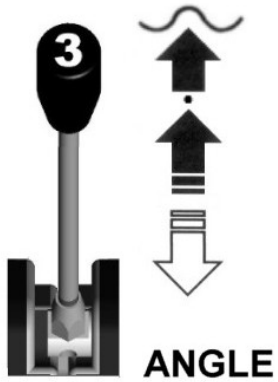
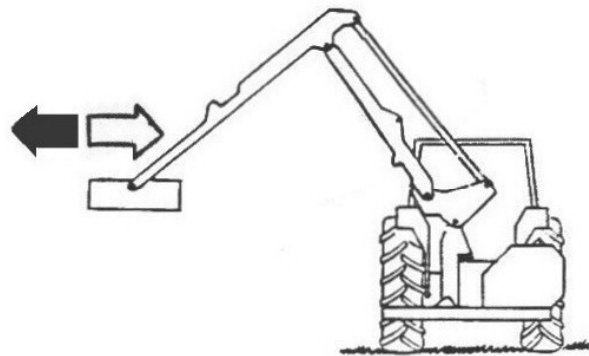
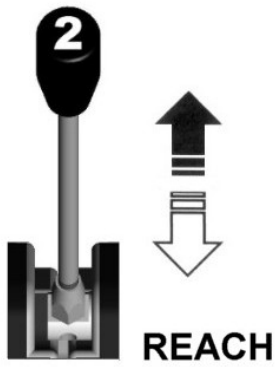
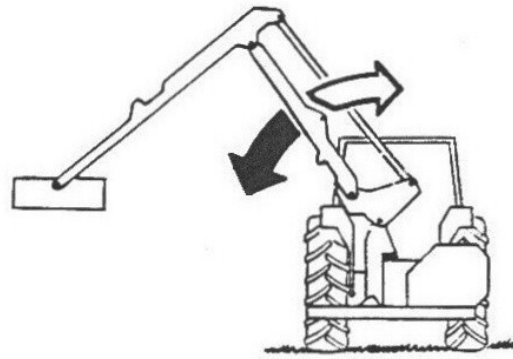
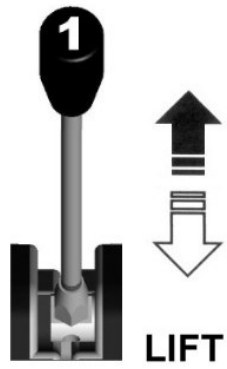

## HYDRAULIC CONTROLS - CUTTING POSITION

The cutting head must at all times be lowered gently into the cutting position. Never 'drop' a flailhead into a hedge at speed.

When cutting at ground level (grass etc.) the head must be lowered gently to give a slight contact pressure of roller to ground.

### WARNING:

Ensure flailhead does not come into contact with obstacles such as rocks, stones, stumps etc. Keep rotor away and free from wire, as to entangle wire in a rotor is both dangerous and costly.

Should large obstacles be encountered or wire become entangled in the rotor **stop immediately** and reset or clear before continuing.

### DANGER WARNING

**Always stop machine, switch off engine and pocket the key before attempting to remove any items that foul the flailhead.**

Normal obstacles and level variations should be overcome by the operator slowing 'forward motion' and raising/lowering the booms of trimmers to suit.

## CUTTING HEAD

The cutting head rotor has been balanced prior to fitting; this will ensure a vibration free cutting unit.

Should the rotor become blocked for any reason, hit an obstacle, loose a blade or blades, the rotor may be put into a state of unbalance. This will result in vibration from the rotor being transmitted through the head. Should this happen **stop immediately**, as to continue may have serious consequences.

Once stopped clean rotor and check for loss of blades and bolts, replace as required.

As a result of hitting solid objects with serious force the rotor can be bent, this will obviously cause vibrations. In such cases the only answer will be to get the rotor repaired/rebalanced or replaced.

Keep the cutting blades VERY SHARP: the flailhead should be inspected daily. Bolts and nuts holding flails to rotor should be checked frequently and kept **tight**. Missing or broken flails should be replaced immediately, as the imbalance will rapidly harm bearings and structure. When a flail is renewed its opposing flail (or pair if using Back to Back flails) should be renewed also in order to maintain balance.

Check 'vee' belt tension on cutter head daily: a load of 5 Kgs (*10 lbs.*) should give a deflection of 9mm at these pulley centres. Access to the belts is by removing the guard panel on the side of the drive end. Tension is adjusted by first slackening the bolts mounting the motor (*nuts are held from turning on the inside*). The nuts on the threaded adjuster can now be turned to give the required tension and then re-tightened and the motor mounting bolts then tightened also.



## **TRANSPORTATION**

---

For transport the machine should be ‘folded’ into a position that is as compact as possible within the confines of the tractor width. The cutting head should be placed into the vertical position with the flails outwards ensuring sufficient clearance of the tractor wheel to avoid possible contact or fouling during transportation.

### **WARNING**

**Never transport a machine with the Booms open -  
Ensure Booms are in contact with each other at all times.**

## CUTTING HEAD 'VEE' BELT ADJUSTMENT

---

To adjust the cutting head 'vee' belts the following procedure should be followed: -

- Position the cutting head on the ground in a safe level location with the drive end uppermost.
- Switch off the tractor engine, remove and pocket the key.
- Remove bolt securing the 'flap-door' of the drive end, this will release the guard flap panel.
- Open upper guard/inspection panel.
- Slacken the 2 bolts holding hydraulic motor to its mounting plate.
- Adjust belt tension by turning the nuts on the tensioning screw
  - *clockwise will tighten the belt, anti-clockwise will slacken the belt.*
- When the correct belt tension is achieved (*refer to diagram below*) the 2 adjustable nuts on the tensioner screw must be locked tight and the 2 bolts securing the motor to the head re-tightened to lock the whole unit into position.

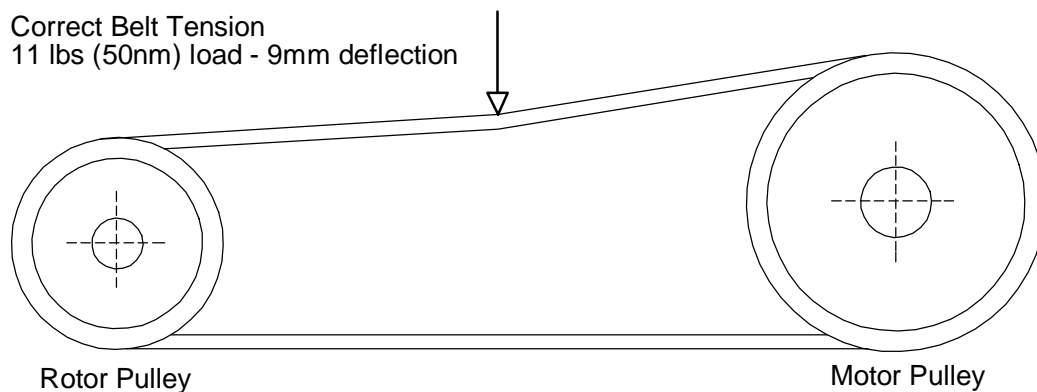

- Re-check tensions when all bolts have been tightened.
- Close flap door and secure with bolt.

**NOTE: Check belt tension on a weekly basis.**



## ROTOR REMOVAL & REPLACEMENT

---

### Removal procedure:

- With the machine attached to the tractor, hydraulically position the cutting head vertically with the drive end downwards resting on the ground – *select a firm level location and ensure the weight of the head is fully rested on the ground.*
- Switch off tractor engine, remove and pocket the key.
- Slacken off and remove the 2 nuts and bolts securing the bearing housing to the flail head main frame at the non-drive end.
- Remove the 4 M12 x 35 setscrews from the drive end (inside shell) - rotor to pulley.
- The whole rotor assembly should now be raised vertically a sufficient amount to allow the drive end location flange to free itself from the locating dowel on the rotor drive pulley.
- With the rotor raised and free of the drive pulley, the drive end of the rotor can be swung gently out of its drive line position in a downward direction relative to the head. With drive end of rotor swung towards base of head the rotor can now be gently lowered to allow non-drive end of rotor, complete with bearing/housing attached, to drop out of main frame and removed.

### Replacement procedure:

- Position flail head as described for removal procedure – *see above.*
- Position rotor vertically with the drive flange end downwards and gently swing in the upper (non-drive end) towards its location position – *this operation is to be carried out from the base face of the head.*
- Locate non-drive end of the rotor up through the head end panel – at the same time as raising and locating the non-drive end of the rotor the lower drive end should be swung into its drive-line position.
- Ensure lower end of rotor (drive flange) is positioned to register with the locating dowel of the drive pulley. Lower rotor onto dowel to locate with the flange making sure both faces seat together correctly.
- Replace the 4 M12 x 35 setscrews to fix the rotor drive flange to the drive pulley and tighten fully. The drive end of the rotor is now connected.
- The upper end of the rotor (bearing housing) is now free/slack. The nuts and bolts for the bearing location should now be fully tightened to complete the rotor fixing.
- Spin the rotor by hand to ensure free, uninterrupted motion.

**NOTE: Rotor mounting bolts should be checked daily to ensure they remain tight.**

## ROLLER HEIGHT ADJUSTMENT

---

The cutting height of the flail head may be adjusted to cut at 4 different heights; this is achieved by altering the mounting position of the roller on the flail head - *refer to diagram below.*

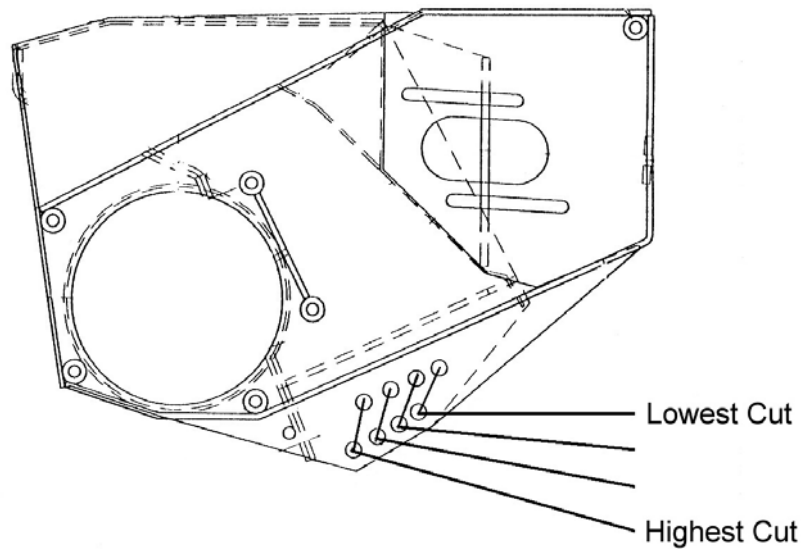

To alter the roller position, each end bracket of the roller and the relative securing bolts will need to be positioned at either of the four position height options offered. Ensure that same opposing location holes on the flail head are chosen.

### **NOTE:**

The flail head roller is generally required only when bank or verge mowing and not when hedgetrimming.

## **REMOVING THE MACHINE FROM THE TRACTOR**

---

Select a good clear, level and firm site on which to detach and store the machine.

### **IMPORTANT**

Use the hydraulics to lower the head onto the ground horizontally (*as if you were cutting grass*).

- Disengage the PTO drive.
- **STOP THE TRACTOR ENGINE.**
- Lower stand legs from their stowed position and place into the 'down' position – fit pins and secure with the lynch pins provided.
- **LINK TYPE STABILIZER:** Remove lynch pins from the stabiliser locating pins, and remove pins. It may be necessary to slightly raise three-point linkage to 'free' pins, for removal.
- **CHAIN TYPE STABILIZER:** Raise machine until chain becomes slack, remove chain from locking slots in lower stabilizer plates.
- Lower hedgetrimmer so stand legs are on the floor, by means of lowering tractor three-point linkage. (*Top link may have to be adjusted to ensure trimmer is upright and safe*).
- When you are sure that trimmer is properly settled and safe on its stands, operate boom '1' lever to release hydraulic pressure from ram.
- Disconnect controls from tractor cab and stow neatly on the machine clear of the ground protected from the elements.
- Disconnect Power Take off shaft and anti-spin chains (*tractor end*).
- Remove lynch pins from lower lift pins and remove pins from linkage - tractor linkage arms are now free of the machine.
- Draw tractor slowly away - Many operators stop about 300mm (12") away to double-check that tractor and machine have completely separated and that no connections or couplings remain connected.

*Safety screens can now be removed if so desired.*

- Replace location pins back through arms of stabiliser assembly and secure in position with lynch pins.
- Re-connect top link bar assembly back onto stabiliser with pin and lynch pin provided.
- Replace lower linkage pins back into relevant positions on mounting frame and secure with lynch pins.
- Ensure tractor top link pin is replaced and secured with lynch pin.

# GENERAL MAINTENANCE

## General Lubrication

The example illustration opposite indicates the general locations of lubrication points - all points should be greased on a daily basis and prior storage of the machine. New machines must be greased prior to first use.

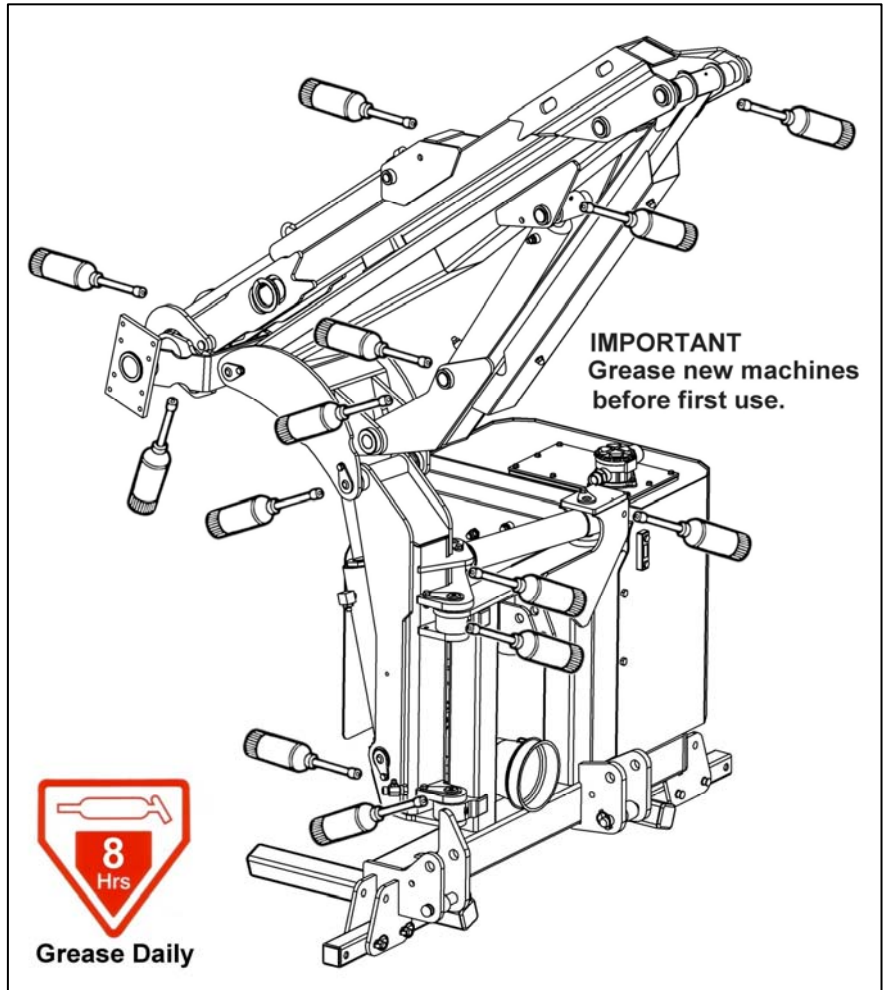

## Gearbox Lubrication

Check gearbox oil level on new machines prior to first use, top up if required before using the machine. Change oil after an initial 50 hours of use and thereafter at annual or 500 hour intervals, whichever occurs earliest.

### Gearbox Capacity:

**0.7 Litre SAE75W90 Fully Synthetic which meets the following minimum requirements;**

Viscosity at 40°C, cSt, 100.0 min.

Viscosity at 100°C, cSt, 17.2 min.

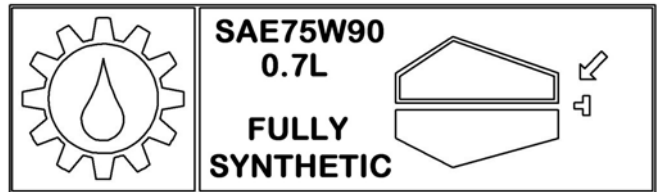

## Replacing Gearbox Oil

Drainage of the gearbox for changes of oil is via the drain plug located on the base of the gearbox.

For refilling or for 'topping up' the oil remove both plugs indicated opposite and fill gearbox via the filler plug to a point where the oil starts to run from the level plug orifice – *replace plugs and tighten securely.*

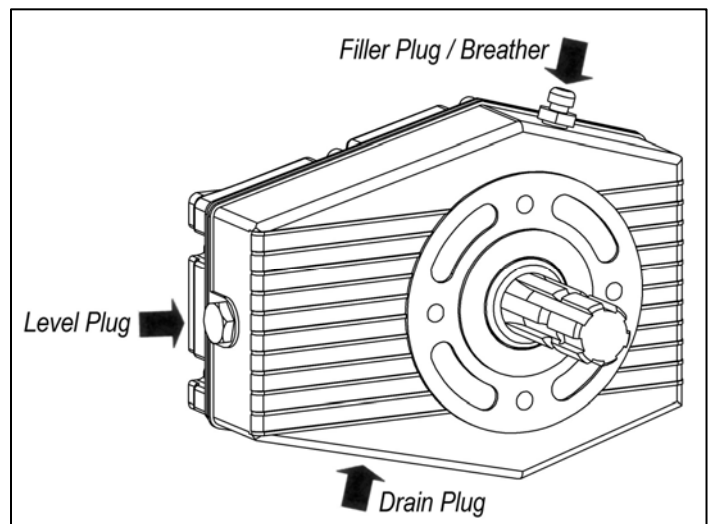

# SERVICE SCHEDULE

---

## Every Day

- Grease machine fully prior to work (and prior to storage).  
*NOTE: New machines must be greased before initial use.*
- Check for broken or damaged flails.
- Check tightness of flail nuts and bolts.
- Visually check for oil leaks and damaged hoses.
- Check all guards and safety shields are correctly fitted and undamaged.
- Ensure all lights are working and clean.
- Check oil level.
- Clean the cooler matrix, in dusty conditions more frequent cleaning is required.

## After initial 12 Hours

- Change return line filter element. *Failure to do so will invalidate the warranty.*  
*Note; factory fitted filter elements are identified differently to replacement elements.*

## After initial 50 Hours

- Change gearbox oil.

## Every 25 Hours

- Grease PTO Shaft universal joints and tubes.

## Every Week

- Check tightness/tension of nuts, bolts and belts.
- Check gearbox oil level.
- Check for wear on telescopic arm pads – *where applicable.*

## Every 100 Hours

- Grease PTO shaft shield lubrication points.

## Every 500 Hours

- Change return line filter element.
- Change gearbox oil.
- Check condition of hydraulic oil and change if required; *when changing oil new return line filter and suction strainer elements should be fitted and return line filter changed again after 12 hours of work.*

## Annually

- Change tank breather.

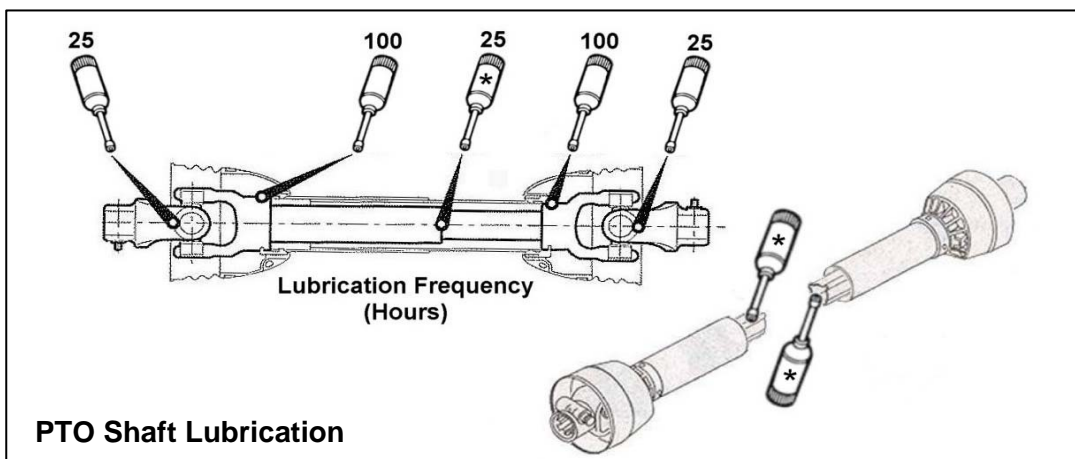



# HYDRAULIC SYSTEM

---

## Oil Supply

Check the oil level in the reservoir daily.

## Oil Condition & Replacement

No fixed time period can be quoted for oil changes as operating conditions can vary widely but a visually inspection of the oil will often indicate its current overall state. Signs of a reduction in its condition will be apparent by changes in colour and appearance when compared to new oil. Oil in poor condition can be dark, smell rancid or burnt, or in some cases be yellow, unclear or milky in appearance indicating the presence of air or emulsified water. Moisture resulting from condensation can become entrapped in the oil causing emulsification that can block the return line filter, consequentially the filter system will be by-passed and the oil and any possible contaminants present will continue to circulate without filtration risking damage to hydraulic components. All are indications or conditions that will require replacement of the oil.

Hydraulic oil is a vital component of the machine; contaminated oil is the root cause of 70% of all hydraulic system failures. Contamination can be reduced by the following:

- Cleaning around the reservoir cap before removal and keeping the tank area clean.
- Use of clean containers when replenishing the system.
- Regular servicing of the filtration system.

## Filtration System

Machines are protected by both replaceable 125 micron suction strainers and low pressure 25 micron full flow return line filters – the diagram below is a ‘scaled up’ view illustrating the filtering capability built into the hydraulic system of the machine:

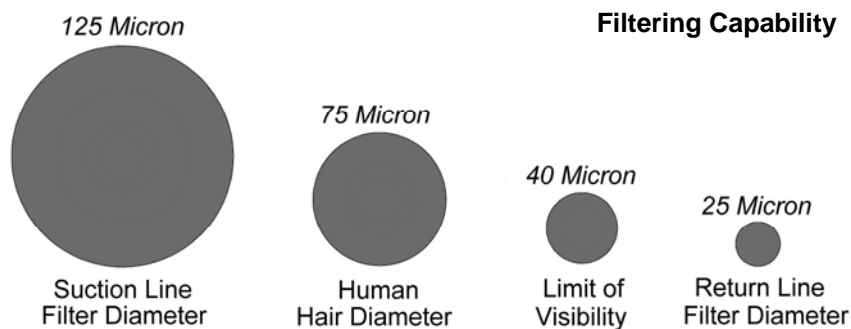

## Suction strainers

The replaceable 125 micron suction strainers are fitted within the hydraulic tank and are ‘screw’ fitted with easy access for removal and replacement.

## Return Line Filter

The 25 micron absolute filter elements should be changed after the first 12 hours and thereafter at 500-hour intervals. It is important to note hours worked as if the filter becomes blocked an internal by-pass within the canister will operate and no symptoms of filter malfunction will occur to jog your memory.

## Tank Breather

To reduce the risk of pump cavitation it is advisable to replace the 25 micron absolute tank breather on an annual basis under normal working conditions – for machines operating in dry dusty environments it is recommended that replacement be increased to 6 monthly.

## HYDRAULIC HOSES

---

The condition of all hoses should be carefully checked during routine service of the machine. Hoses that have been chaffed or damaged on their outer casing should be securely wrapped with waterproof adhesive tape to stop the metal braid from rusting. Hoses that have suffered damage to the metal braid should be changed at the earliest opportunity.

### Hose Replacement

Before changing any hoses take the time to study the existing installation as the routing has been carefully calculated to prevent hose damage during operation - always replace hoses in exactly the same location and manner. This is especially important for the flail hoses where they must be crossed, upper to lower, at the dipper and head pivots.

- Always replace one hose at a time to avoid the risk of wrong connections.
- When the hose is screwed to an additional fitting or union, use a second spanner on the union to avoid breaking both seals.
- Do not use jointing compound on the threads.
- Avoid twisting the hose. Adjust the hose line to ensure freedom from rubbing or trapping before tightening hose end connections.

Hydraulic Hoses (BSP) fitted to Twose Series Hedgecutters have ‘soft seal’ connections on both flail and ram circuit hoses.

Recommended torque settings for nut security are as follows:

SIZE		TORQUE SETTING	O Ring Ref.
1/4" BSP	=	24 Nm <i>or</i> 18 lb.ft.	10 000 01
3/8" BSP	=	33 Nm <i>or</i> 24 lb.ft.	10 000 02
1/2" BSP	=	44 Nm <i>or</i> 35 lb.ft.	10 000 03
5/8" BSP	=	58 Nm <i>or</i> 43 lb.ft.	10 000 04
3/4" BSP	=	84 Nm <i>or</i> 62 lb.ft.	10 000 05
1" BSP	=	115 Nm <i>or</i> 85 lb.ft.	10 000 06

For hose unions (BSP) fitted in conjunction with bonded seals the recommended torque settings are as follows:

SIZE		TORQUE SETTING
1/4" BSP	=	34 Nm <i>or</i> 25 lb.ft.
3/8" BSP	=	75 Nm <i>or</i> 55 lb.ft.
1/2" BSP	=	102 Nm <i>or</i> 75 lb.ft.
5/8" BSP	=	122 Nm <i>or</i> 90 lb.ft.
3/4" BSP	=	183 Nm <i>or</i> 135 lb.ft.
1" BSP	=	203 Nm <i>or</i> 150 lb.ft.

### Safety Note:

Soft seal hose connections are capable of holding pressure when the nut is only ‘finger tight’. It is therefore recommended during dismantling that the hose be manually flexed to relieve any residual pressure with the retaining nut slackened prior to complete disassembly.

## CONTROL CABLES

---

The control cables operate on a push/pull system with the spool centring springs always returning the spool to the neutral position when the handle is released.

Care should be taken during installation and operation to ensure that the cables are not trapped or kinked. Any abrasion or damage to the outer casing should be sealed with plastic insulation tape to avoid moisture penetrating.

No routine adjustments of the cables are necessary, as they do not stretch. The threaded collar is correctly adjusted when the lever is in a vertical position in its housing allowing an equal amount of travel in either direction.

### CAUTION

**On no account should any attempt be made to lubricate the cables – these are assembled with a special ‘lifelong’ lubricant during manufacture and will not require any additional lubrication.**

**Note:** Take care to ascertain the correct cable connections on both the control unit and the valve in the event of cable replacement.

# PTO SHAFT MAINTENANCE

## PTO Shaft Lubrication

The PTO shaft should be lubricated on a regular basis using lithium based grease – each end of the shaft has 2 greasing points; one for lubrication of the universal joint and one for lubricating the rotating fixing ring of the shaft shield – access to the lubrication points is gained by releasing the shaft shield from its fixing ring and sliding it back along the body of the driveshaft as shown below.



Shaft shield fixing clasps



Insert screwdrivers into the clasps



Prise clasps open to release the shield



Slide shield back to reveal universal joint

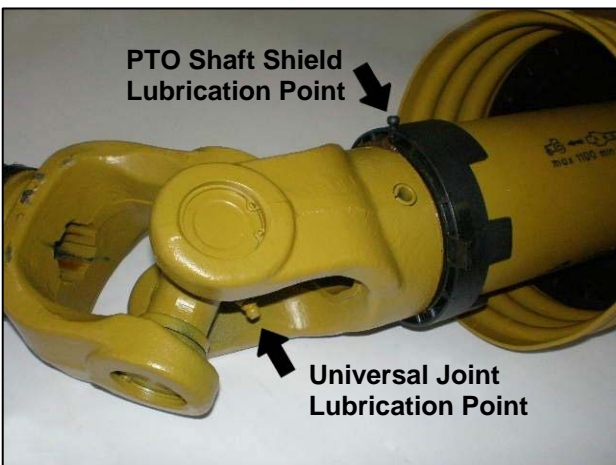

Location of lubrication points



Recommended lubricating frequency

Slide the shaft shield back into place after lubrication ensuring the clasps relocate correctly in the fixing ring – always fit torque chains to the shields to stop them from rotating with the shaft during operation.

# TORQUE SETTINGS FOR FASTENERS

The chart below lists the correct tightening torque for fasteners. This chart should be referred to when tightening or replacing bolts in order to determine the grade of bolt and the correct torque unless specific torque values are assigned in the text of the manual.

*Recommended torque is quoted in Foot-Pounds and Newton-Metres within this manual. The equation for conversion is 1 Nm. = 1.356 ft. lbs.*

## TORQUE VALUES FOR IMPERIAL BOLTS

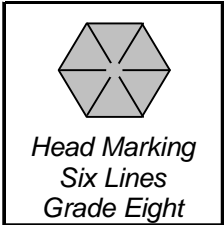
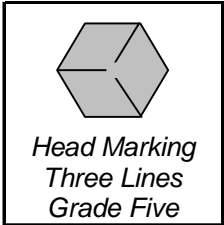
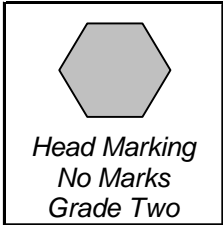

**NOTE:**  
The values in the chart apply to fasteners as received from the supplier, dry or when lubricated with normal engine oil. They DO NOT apply if special graphited, molydisulphide greases, or other extreme pressure lubricants are used. This applies to both UNF and UNC coarse threads.

Bolt Dia.
1/4"
5/16"
3/8"
7/16"
1/2"
9/16"
5/8"
3/4"
7/8"
1"
1-1/8"
1-1/4"
1-3/8"
1-1/2"

Value (Dry)	
ft.lb.	Nm.
5.5	7.5
11	15.0
20	27.0
32	43.0
50	68.0
70	95.0
100	135.0
175	240.0
175	240.0
270	360.0
375	510.0
530	720.0
700	950.0
930	1250.0

Value (Dry)	
ft.lb.	Nm.
9	12.2
18	25.0
33	45.0
52	70.0
80	110.0
115	155.0
160	220.0
280	380.0
450	610.0
675	915.0
850	115.0
1200	1626.0
1550	2100.0
2100	2850.0

Value (Dry)	
ft.lb.	Nm.
12.5	17.0
26	35.2
46	63.0
75	100.0
115	155.0
160	220.0
225	305.0
400	540.0
650	880.0
975	1325.0
1350	1830.0
1950	2650.0
2550	3460.0
3350	4550.0

## TORQUE VALUES FOR METRIC BOLTS.

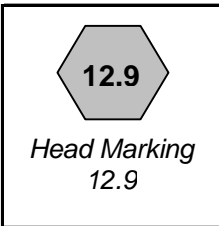
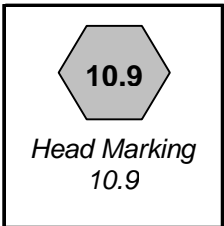
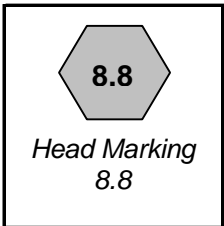
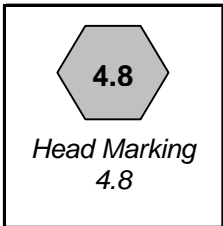

Bolt Dia.
6mm
8mm
10mm
12mm
14mm
16mm
18mm
20mm
22mm
24mm
27mm
30mm

Value (Dry)	
ft.lb.	Nm.
4.5	6.1
11	14.9
21	28.5
37	50.2
60	81.4
92	125.0
125	170.0
180	245.0
250	340.0
310	420.0
450	610.0
625	850.0

Value (Dry)	
ft.lb.	Nm.
8.5	11.5
20	27.1
40	54.2
70	95.0
110	150.0
175	240.0
250	340.0
350	475.0
475	645.0
600	810.0
875	1180.0
1200	1626.0

Value (Dry)	
ft.lb.	Nm.
12	16.3
30	40.1
60	81.4
105	140.0
165	225.0
255	350.0
350	475.0
500	675.0
675	915.0
850	1150.0
1250	1700.0
1700	2300.0

Value (Dry)	
ft.lb.	Nm.
14.5	20.0
35	47.5
70	95.0
120	160.0
190	260.0
300	400.0
410	550.0
580	790.0
800	1090.0
1000	1350.0
1500	2000.0
2000	2700.0



McConnel Limited, Temeside Works, Ludlow, Shropshire SY8 1JL. England.  
Telephone: 01584 873131. Facsimile: 01584 876463. [www.mcconnel.com](http://www.mcconnel.com)