

# **TWOSE SWINGCLIP**

Swingover Cutterbar Trimmer

Operation Manual

Publication 761

January 2014



# IMPORTANT VERIFICATION OF WARRANTY REGISTRATION



## DEALER WARRANTY INFORMATION & REGISTRATION VERIFICATION

It is imperative that the selling dealer registers this machine with Twose of Tiverton Limited before delivery to the end user – failure to do so may affect the validity of the machine warranty.

To register machines go to the Twose web site at [www.twose.com](http://www.twose.com), log onto 'Dealer Inside' and select the 'Machine Registration button' which can be found in the Service Section of the site. Confirm to the customer that the machine has been registered in the section below.

Should you experience any problems registering a machine in this manner please contact the Twose Office on 01884 253691.

### Registration Verification

Dealer Name: .....
Dealer Address: .....
Customer Name: .....
Date of Warranty Registration: ...../...../..... Dealer Signature: .....

### NOTE TO CUSTOMER / OWNER

*Please ensure that the above section above has been completed and signed by the selling dealer to verify that your machine has been registered with Twose of Tiverton Limited.*

**IMPORTANT:** During the initial 'bedding in' period of a new machine it is the customer's responsibility to regularly inspect all nuts, bolts and hose connections for tightness and re-tighten if required. New hydraulic connections occasionally weep small amounts of oil as the seals and joints settle in – where this occurs it can be cured by re-tightening the connection – *refer to torque settings chart below*. The tasks stated above should be performed on an hourly basis during the first day of work and at least daily thereafter as part of the machines general maintenance procedure.

### TORQUE SETTINGS FOR HYDRAULIC FITTINGS

HYDRAULIC HOSE ENDS		
BSP	Setting	Metric
1/4"	18 Nm	19 mm
3/8"	31 Nm	22 mm
1/2"	49 Nm	27 mm
5/8"	60 Nm	30 mm
3/4"	80 Nm	32 mm
1"	125 Nm	41 mm
1.1/4"	190 Nm	50 mm
1.1/2"	250 Nm	55 mm
2"	420 Nm	70 mm

PORT ADAPTORS WITH BONDED SEALS		
BSP	Setting	Metric
1/4"	34 Nm	19 mm
3/8"	47 Nm	22 mm
1/2"	102 Nm	27 mm
5/8"	122 Nm	30 mm
3/4"	149 Nm	32 mm
1"	203 Nm	41 mm
1.1/4"	305 Nm	50 mm
1.1/2"	305 Nm	55 mm
2"	400 Nm	70 mm

# WARRANTY POLICY

## WARRANTY REGISTRATION

All machines must be registered, by the selling dealer with Twose of Tiverton Ltd, before delivery to the end user. On receipt of the goods it is the buyer's responsibility to check that the Verification of Warranty Registration in the Operator's Manual has been completed by the selling dealer.

### 1. LIMITED WARRANTIES

- 1.01. *All machines supplied by Twose of Tiverton Ltd are warranted to be free from defects in material and workmanship from the date of sale to the original purchaser for a period of 12 months, unless a different period is specified.*
- 1.02. *All spare parts supplied by Twose of Tiverton Ltd and purchased by the end user are warranted to be free from defects in material and workmanship from the date of sale to the original purchaser for a period of 6 months. All parts warranty claims must be supported by a copy of the failed part invoice to the end user. We cannot consider claims for which sales invoices are not available.*
- 1.03. *The warranty offered by Twose of Tiverton Ltd is limited to the making good by repair or replacement for the purchaser any part or parts found, upon examination at its factory, to be defective under normal use and service due to defects in material or workmanship. Returned parts must be complete and unexamined. Pack the component(s) carefully so that any transit damage is avoided. All ports on hydraulic items should be drained of oil and securely plugged to prevent seepage and foreign body ingress. Certain other components, electrical items for example, may require particular care when packing to avoid damage in transit.*
- 1.04. *This warranty does not extend to any product from which Twose of Tiverton Ltd's serial number plate has been removed or altered.*
- 1.05. *This warranty does not apply to any part of the goods, which has been subjected to improper or abnormal use, negligence, alteration, modification, fitment of non-genuine parts, accident damage, or damage resulting from contact with overhead power lines, damage caused by foreign objects (e.g. stones, iron, material other than vegetation), failure due to lack of maintenance, use of incorrect oil or lubricants, contamination of the oil, or which has served its normal life. This warranty does not apply to any expendable items such as blades, belts, clutch linings, filter elements, flails, flap kits, skids, soil engaging parts, shields, guards, wear pads, pneumatic tyres or tracks.*
- 1.06. *Temporary repairs and consequential loss - i.e. oil, downtime and associated parts are specifically excluded from the warranty.*
- 1.07. *Warranty on hoses is limited to 12 months and does not include hoses which have suffered external damage. Only complete hoses may be returned under warranty, any which have been cut or repaired will be rejected.*
- 1.08. *Machines must be repaired immediately a problem arises. Continued use of the machine after a problem has occurred can result in further component failures, for which Twose of Tiverton Ltd cannot be held liable, and may have safety implications.*
- 1.09. *If in exceptional circumstances a non Twose of Tiverton Ltd part is used to effect a repair, warranty reimbursement will be at no more than Twose of Tiverton Ltd's standard dealer cost for the genuine part.*
- 1.10. *Except as provided herein, no employee, agent, dealer or other person is authorised to give any warranties of any nature on behalf of Twose of Tiverton Ltd.*
- 1.11. *For machine warranty periods in excess of 12 months the following additional exclusions shall apply:*
  - 1.11.1. *Hoses, exposed pipes and hydraulic tank breathers.*
  - 1.11.2. *Filters.*
  - 1.11.3. *Rubber mountings.*
  - 1.11.4. *External electric wiring.*
  - 1.11.5. *Bearings and seals.*

- 1.12. All service work, particularly filter changes, must be carried out in accordance with the manufacturer's service schedule. Failure to comply will invalidate the warranty. In the event of a claim, proof of the service work being carried out may be required.
- 1.13. Repeat or additional repairs resulting from incorrect diagnosis or poor quality previous repair work are excluded from warranty.

**NB Warranty cover will be invalid if any non-genuine parts have been fitted or used. Use of non-genuine parts may seriously affect the machine's performance and safety. Twose of Tiverton Ltd cannot be held responsible for any failures or safety implications that arise due to the use of non-genuine parts.**

## **2. REMEDIES AND PROCEDURES**

- 2.01. The warranty is not effective unless the Selling Dealer registers the machine, via the Twose of Tiverton Ltd web site and confirms the registration to the purchaser by completing the confirmation form in the operator's manual.
- 2.02. Any fault must be reported to an authorised Twose of Tiverton Ltd dealer as soon as it occurs. Continued use of a machine, after a fault has occurred, can result in further component failure for which Twose of Tiverton Ltd cannot be held liable.
- 2.03. Repairs should be undertaken within two days of the failure. Claims submitted for repairs undertaken more than 2 weeks after a failure has occurred, or 2 days after the parts were supplied will be rejected, unless the delay has been authorised by Twose of Tiverton Ltd. Please note that failure by the customer to release the machine for repair will not be accepted as a reason for delay in repair or submitting warranty claims.
- 2.04. All claims must be submitted, by an authorised Twose of Tiverton Ltd Service Dealer, within 30 days of the date of repair.
- 2.05. Following examination of the claim and parts, Twose of Tiverton Ltd will pay, at their discretion, for any valid claim the invoiced cost of any parts supplied by Twose of Tiverton Ltd and appropriate labour and mileage allowances if applicable.
- 2.06. The submission of a claim is not a guarantee of payment.
- 2.07. Any decision reached by Twose of Tiverton Ltd is final.

## **3. LIMITATION OF LIABILITY**

- 3.01. Twose of Tiverton Ltd disclaims any express (except as set forth herein) and implied warranties with respect to the goods including, but not limited to, merchantability and fitness for a particular purpose.
- 3.02. Twose of Tiverton Ltd makes no warranty as to the design, capability, capacity or suitability for use of the goods.
- 3.03. Except as provided herein, Twose of Tiverton Ltd shall have no liability or responsibility to the purchaser or any other person or entity with respect to any liability, loss, or damage caused or alleged to be caused directly or indirectly by the goods including, but not limited to, any indirect, special, consequential, or incidental damages resulting from the use or operation of the goods or any breach of this warranty. Notwithstanding the above limitations and warranties, the manufacturer's liability hereunder for damages incurred by the purchaser or others shall not exceed the price of the goods.
- 3.04. No action arising out of any claimed breach of this warranty or transactions under this warranty may be brought more than one (1) year after the cause of the action has occurred.

## **4. MISCELLANEOUS**

- 4.01. Twose of Tiverton Ltd may waive compliance with any of the terms of this limited warranty, but no waiver of any terms shall be deemed to be a waiver of any other term.
- 4.02. If any provision of this limited warranty shall violate any applicable law and is held to be unenforceable, then the invalidity of such provision shall not invalidate any other provisions herein.
- 4.03. Applicable law may provide rights and benefits to the purchaser in addition to those provided herein.



# DECLARATION OF CONFORMITY

*Conforming to EU Machinery Directive 2006/42/EC*

We,

**TWOSE of TIVERTON LIMITED,**  
6 Chinon Court, Lower Moor Way,  
Tiverton Business Park, Tiverton, Devon, EX16 6SS, UK

*Hereby declare that:*

The Product; *Tractor Mounted Cutterbar Mower*

Product Code; *SWTR*

Serial No. & Date ..... Type .....

Manufactured in; *United Kingdom*

Complies with the required provisions of the Machinery Directive 2006/42/EC  
The machinery directive is supported by the following harmonized standards;

- BS EN ISO 12100 (2010) Safety of machinery – General principles for design – Risk assessment and risk reduction.
- BS EN 349 (1993) + A1 (2008) Safety of machinery - Minimum distances to avoid the entrapment with human body parts.
- BS EN 953 (1997) + A1 (2009) Safety of machinery - Guards general requirements for the design and construction of fixed and movable guards.
- BS EN 4413 (2010) Hydraulic fluid power. Safety requirements for systems and their components.

Signed  ..... *Responsible Person*  
*CHRISTIAN DAVIES on behalf of TWOSE OF TIVERTON LIMITED*

Status: *General Manager*

Date: *September 2015*

## LIST OF CONTENTS

---

### OPERATOR SECTION

General Information	1
Safety Information	2
Tractor Requirements	5
Tractor Preparation	6
Machine Fitting	7
Machine Removal	9
Storage	9
Operation	10
Maintenance	14
Cutterbar	15
Hydraulic Rams	17
Hydraulic System	18
Control Valve	20
Hydraulic Hoses	22
Pump & Tank Kit	23
Hydraulic Installations	24
Proportional Valve Wiring & Connections	25





## GENERAL INFORMATION

---

Always read this manual before fitting or operating the machine – whenever any doubt exists contact your dealer or the Twose Service Department for advice and assistance.

### Use only Twose Genuine Service Parts on Twose Equipment and Machines

**DEFINITIONS** – The following definitions apply throughout this manual:

#### WARNING

An operating procedure, technique etc., which –  
can result in personal injury or loss of life if not observed carefully.

#### CAUTION

An operating procedure, technique etc., which –  
can result in damage to either machine or equipment if not observed carefully.

#### NOTE

An operating procedure, technique etc., which –  
is considered essential to emphasis.

#### LEFT AND RIGHT HAND

This term is applicable to the machine when attached to the tractor and is viewed  
from the rear – this also applies to tractor references.

## MACHINE & DEALER INFORMATION

*Record the Serial Number of your machine on this page and always quote this number when ordering parts. Whenever information concerning the machine is requested remember also to state the make and model of tractor to which the machine is fitted.*

Machine Serial Number:	Installation Date:
Machine Model details:	
Dealer Name:	
Dealer Address:	
Dealer Telephone No:	
Dealer Email Address:	

## SAFETY INFORMATION

---

There are obvious and hidden potential hazards involved in the operation of this implement. Serious injury or death may occur unless care is taken to insure the safety of both the operator and any other persons in the area. **KEEP CLEAR AT ALL TIMES**

The following is a list of some safeguards which should be followed. Serious injury or death may occur unless care is taken.

- ▲ Where this is used as a rear-mounted implement it will remove weight from the front wheels – this can result in less of steering and risk of overturn. Add front end weight to ensure 20% of tractor original weight is on the front wheels when the boom is in transport position. This will aid steering safety reducing the risk of bodily injury.
- ▲ Always transport slowly on rough surface to prevent ‘bouncing’ of the front wheels causing loss of steering and possible injury.
- ▲ Always set tractor wheel width as wide as possible and add weights to the relevant opposite wheel to counteract the weight of an extended implement.
- ▲ Operate the machine only with a tractor equipped with an approved roll-over-protection system (ROPS). Always wear approved seat belts whenever the tractor or machine is running. Serious injury or death could result from falling off the tractor seat. Do not alter the ROPS structure.
- ▲ Always ensure that check chains/stabilizers are fitted and are in good condition and tight.
- ▲ The operator and all support personnel should wear ‘Safety Shoes’, ‘Hard Hats’, and ‘Safety Glasses’ at all times to protect them against falling objects.
- ▲ Never allow inexperienced or untrained personnel to operate the tractor/cutterbar combination without training or supervision.
- ▲ Always familiarise yourself with the controls in a clear safe area before commencing work.
- ▲ Always familiarise yourself with the local highway regulations and abide by them at all times.
- ▲ The boom and cutterhead change the balance of the machine in transport. Be especially careful when transporting on slopes. Never turn uphill in transport except at very slow speed and a low rate of turn. Never transport or operate this machine on steep slopes. **BE CAREFUL.**
- ▲ Always inspect the work area or hedgerow for wire, steel posts, or other dangerous materials and remove them if possible before commencing work.
- ▲ Always operate the machine at the recommended PTO speed. Never exceed the maximum permitted.
- ▲ When the cutterhead is swung to the side (working position) of the tractor, it exerts a momentum on the tractor causing the tractor to rock from side-to-side. Extreme Care should be taken when operating on slopes, Bodily Harm or Death could result from tractor's tipping over.

- ▲ Never swing the arms of the machine over if the tractor is facing sideways, across or facing down a slope. If swinging over on sloping ground is unavoidable the tractor must always face directly up the slope.
- ▲ Never allow riders on the tractor. Never lift a person with the boom or cutterhead. KEEP BYSTANDERS CLEAR.
- ▲ Inspect the entire machine periodically. Look for loose bolts, worn or broken parts, pinched hydraulic hoses, and leaky or loose fittings. Make sure all pins are secure: Serious injury may occur from not maintaining this machine in good working order.
- ▲ Do not mount tractor when tractor is moving. Avoid serious injury or death from contact with the rotating tyres. Mount and dismount the tractor only when it is completely stopped, do not grasp the control levers when mounting or dismounting the tractor.
- ▲ Always take extreme care when working around overhead obstructions. When working close to overhead power lines consult your electric company for a safe code of operation.
- ▲ The boom is designed only to position the cutterhead which is attached to it. Never attempt to lift, pull, or push other objects with it. Serious injury could result from a structural failure when the boom is used for purposes other than those for which it was designed.
- ▲ The boom on this machine has a safety 'breakback' system with automatic return to the work position, never allow anyone to stand in front of the boom or cutterhead in a position where they could be injured if the boom were to move forward suddenly.
- ▲ Always at all times keep fingers away from the cutter knife as it can be operated by a movement of the crankshaft fly wheel caused by gravity even though the tractor engine is switched off. When clearing any blockage always lay the cutterbar flat on the ground, switch off the tractor, clamp the cutter knife firmly and remove the blockage using a suitable tool.
- ▲ Do not operate the machine with hydraulic oil leaking. Oil is expensive, and its presence could present a hazard. Do not check for leaks with your hand-use cardboard. High-pressure oil can penetrate the skin and cause GANGRENE. If oil does penetrate the skin, have it surgically removed at once by a surgeon knowledgeable in this procedure.
- ▲ Never become complacent and ignore any safety instructions. Always check all nuts, bolts, hoses and other fixings daily for tightness, security and damage. Repair immediately if require Always transport the machine in the recommended position (see instructions in transport section) with the cutterbar guard in position.
- ▲ Never walk or work under any raised boom or cutterhead. The boom could fall and cause serious bodily injury or death. Always lower the boom and cutterhead flat on the ground or support the boom and cutterhead on safety stands. Unload all hydraulic actuators prior to doing any maintenance. Set the cutterhead on the ground, then kill the tractor engine. Push and pull the Control levers in and out several times to remove pressure.
- ▲ Do not work under raised boom or cutterhead unless components are securely blocked up to prevent inadvertent dropping.

- ▲ Always read carefully and comply fully with the manufacturer's instructions when handling oil, solvents, cleansers and any other chemical agents.
- ▲ Always maintain the safety decals in good readable condition. If the decals become damaged or unreadable, reorder them immediately.
- ▲ In addition to the design and configuration of this implement, including safety signs and safety equipment, hazard control and accident prevention are dependent upon the awareness, concern, prudence, and proper training of personnel involved in the operation, transport, maintenance, and storage of the machine. Refer also to safety messages and operation instruction in each of the appropriate sections of the tractor and machine manuals. Pay close attention to the safety signs affixed to the tractor and machine.

---

**Although the information given here covers a wide range of safety subjects, it is impossible to predict every eventuality that can occur under differing circumstances whilst operating this machine. No advice given here can replace 'good common sense' and 'total awareness' at all times, but it will go a long way towards the safe use of your Twose machine.**

---

## TRACTOR REQUIREMENTS

Swingclip machines are specifically designed to be fitted to all tractors with category 1 linkage facility and a minimum weight (*inclusive of ballast*) to manufacturer's specifications of 650 kg (1430 lbs).

### Check Chains & Stabiliser Bars

Check chains and/or stabiliser bars must be available to hold the machine firmly in position during transport and operation.

### Relief Valve

Tractors used must have a relief valve setting of between 2000 – 3000 psi (110 - 210 Bar).  
NOTE: Tractors that operate on a 'closed centre' hydraulic principle are unsuitable for use.

### Tractor Flow Requirements

12 – 20 LPM for machines fitted with a low flow motor.

21 – 30 LPM for machines fitted with a high flow motor.

### PTO Speeds

Build Specification	Low Flow Motors	High Flow Motors
Pump & Tank Kit 1090258	370 RPM ( <i>Max.</i> )	650 RPM ( <i>Max.</i> )
Pump & Tank Kit 1090346	230 RPM ( <i>Max.</i> )	405 RPM ( <i>Max.</i> )

### Stability

Irrespective of the size of the tractor it must be stable during transport and operation of the machine at all times under all conditions. Due regard must be paid to operating on slopes - front end ballast and rear wheel weights should be added as appropriate to counterbalance overhang of the cutterbar – refer to vehicle/tractor preparation page for further information on this subject.

### Pump & Tank Kit Requirement

A minimum distance of 550mm must be available between the attachment point of the machine and the rear of the tractor's PTO output shaft for fitment of a Pump & Tank Kit.

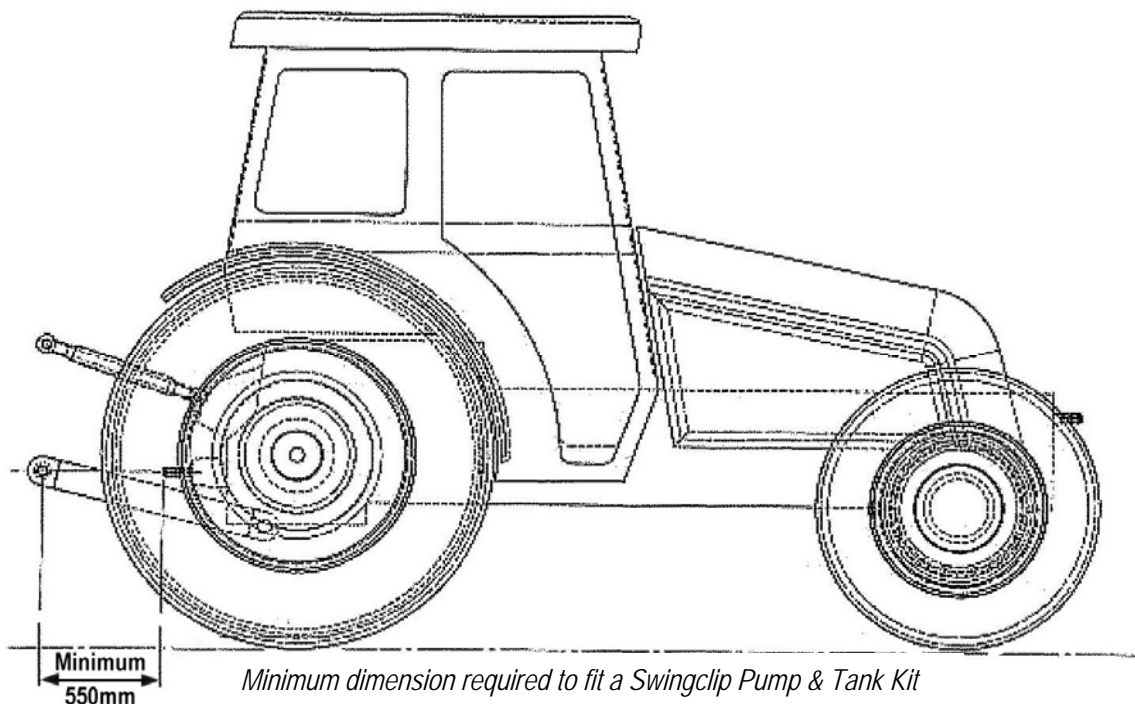

## VEHICLE / TRACTOR PREPARATION

---

We recommend vehicles are fitted with cabs using 'safety glass' windows and protective guarding when used with our machines.

Fit Operator Guard (*Part No. 7313324*) using the hooks provided. Shape the mesh to cover all vulnerable areas.

Remember the driver must be looking through mesh and/or polycarbonate glazing

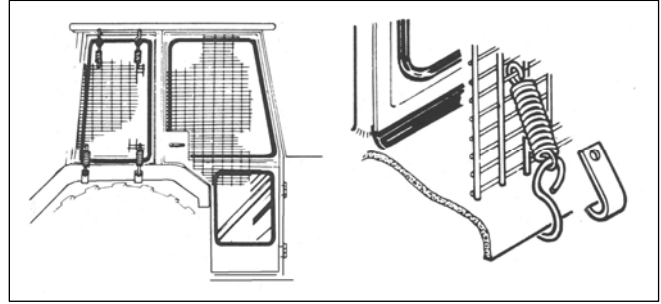

when viewing the cutterhead in any working position - unless the vehicle/ cab manufacturer can demonstrate that the penetration resistance is equivalent to, or higher than, that provided by mesh/polycarbonate glazing. If the tractor has a roll bar only, a frame must be made to carry both mesh and polycarbonate glazing. The operator should also use personal protective equipment to reduce the risk of serious injury such as; eye protection (mesh visor to EN1731 or safety glasses to EN166), hearing protection to EN352, safety helmet to EN297, gloves, filter mask and high visibility clothing.

### Vehicle Ballast

It is imperative when attaching 'third-party' equipment to a vehicle that the maximum possible stability of the machine and vehicle combination is achieved – this can be accomplished by the utilisation of 'ballast' in order to counter-balance the additional equipment added.

Front weights may be required for rear mounted machines to place 15% of total outfit weight on the front axle for stable transport on the road and to reduce 'crabbing' due to the drag of the cutting unit when working on the ground.

Rear weights may be required to maintain a reasonable amount of rear axle load on the opposite wheel from the arms when in work; for normal off-ground work i.e. hedge cutting this should be 20% of rear axle weight or more for adequate control, and for ground work i.e. verge mowing with experienced operators, this can be reduced to 10%.

All factors must be addressed in order to match the type and nature of the equipment added to the circumstances under which it will be used.

### Factors that effect stability

- *Centre of gravity of the tractor/machine combination.*
- *Geometric conditions, e.g. position of the cutting head and ballast.*
- *Weight, track width and wheelbase of the tractor.*
- *Acceleration, braking, turning and the relative position of the cutting head during these operations.*
- *Ground conditions, e.g. slope, grip, load capability of the soil/surface.*
- *Rigidity of implement mounting.*

### Suggestions to increase stability

- *Increasing rear wheel track; a vehicle with a wider wheel track is more stable.*
- *Ballasting the wheel; it is preferable to use external weights but liquid can be added to around 75% of the tyre volume – water with anti-freeze or the heavier Calcium Chloride alternative can be used.*
- *Addition of weights – care should be taken in selecting the location of the weights to ensure they are added to a position that offers the greatest advantage.*
- *Front axle locking, check with tractor manufacturer.*

---

The advice above is offered as a guide for stability only and is not a guide to vehicle strength. It is therefore recommended that you consult your vehicle manufacturer or local dealer to obtain specific advice on this subject, additionally advice should be sought from a tyre specialist with regard to tyre pressures and ratings suitable for the type and nature of the machine you intend to fit.

---

## FITTING THE MACHINE

---

### Attachment to Tractor

Attachment of the machine to the tractor should be performed on a firm level site.

The procedure for attachment is as follows:

- Unbolt the upper halves of the yoke and fit them either side of the tractor's top hitch bracket with the  $\frac{3}{4}$ " UNF nut and bolt provided. *If the tractor has only one top hitch position the bolt will replace the existing top hitch pin.* If more than one location is available mount the yokes through an alternative position as it will make it easier to put the machine on and off the tractor. *Do not tighten the nut at this stage.*
- Attach the machine to the three point linkage and raise it to give 200 - 250mm (8" – 9") clearance under the lowest part of the frame.
- Re-bolt the yoke halves together - *it may be necessary to raise or lower the machine on the linkage to achieve hole alignment.*
- Adjust the top link until the main frame is vertical.
- Tighten the nut and bolt securing the upper yoke just enough to eliminate any sideways movement. *Do not over tighten and 'squeeze' the top hitch brackets.*
- Tighten the check chains/stabiliser bars.
- Bolt controls mounting bracket to suitable location on the tractor.
- Turn the parking leg upside down and pin in position.
- Couple up the hydraulics – see following page.

### Front Mounting

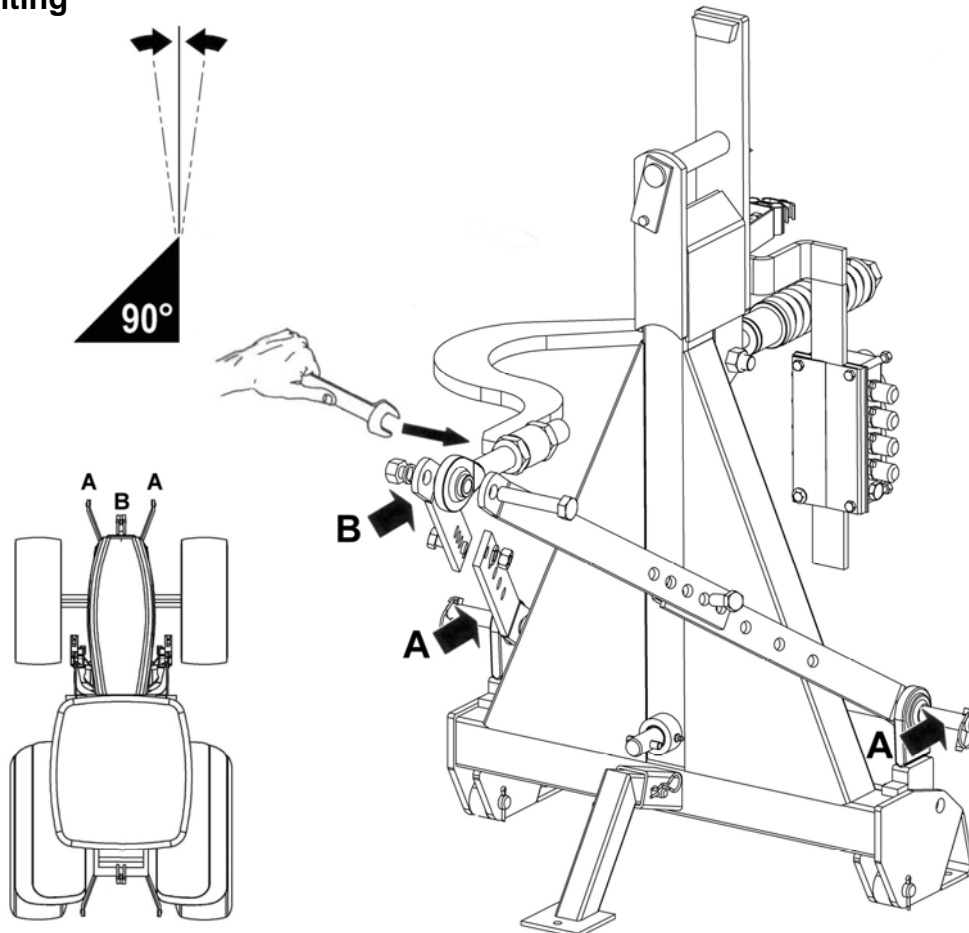

## Coupling up Hydraulics

Consult the tractor's handbook for correct installation of the supply and return connection.

*NOTE: Ensure the connection used is to a supply that is isolated from the tractor linkage.*

The motor drain line must always be returned to a low pressure position i.e. transmission filler plug. Where no specific return connection is available and the transmission filler plug has to be used, an adaptor must be fitted, which, then allows the motor return and the motor drain to utilise a common return location.

Note: On delivery of the machine the drain line will be fitted with a blanking plug - this must be removed and replaced with the elbow fitting (Part No. 8581329) supplied with the machine as a loose item, this in turn must then be connected to the reservoir using one or other of the supplied conical plugs before the motor is run.

### Motor Drain Line

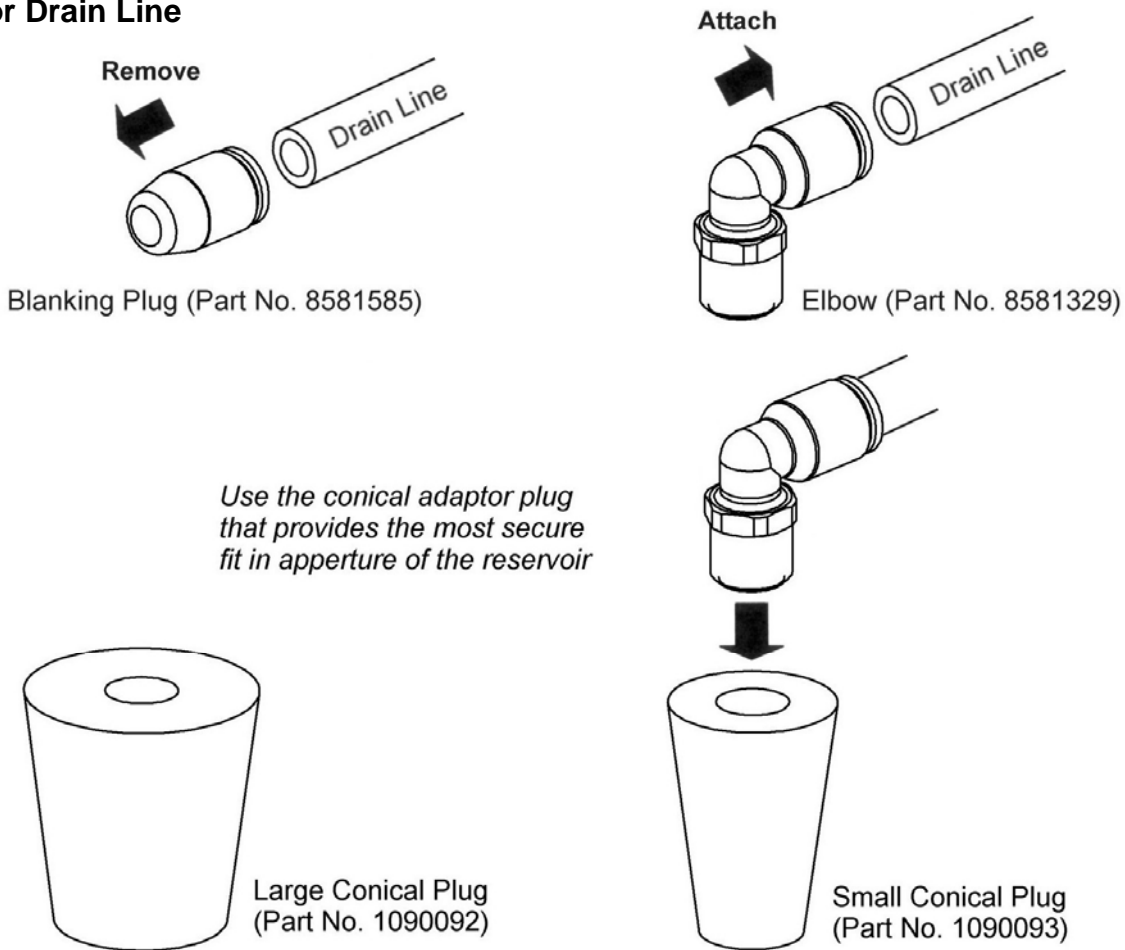

Run up the machine and operate through its complete range of movements including the operation of the cutterbar drive. Check the tractor's transmission oil level and top up if necessary. You are now ready to proceed to the worksite.

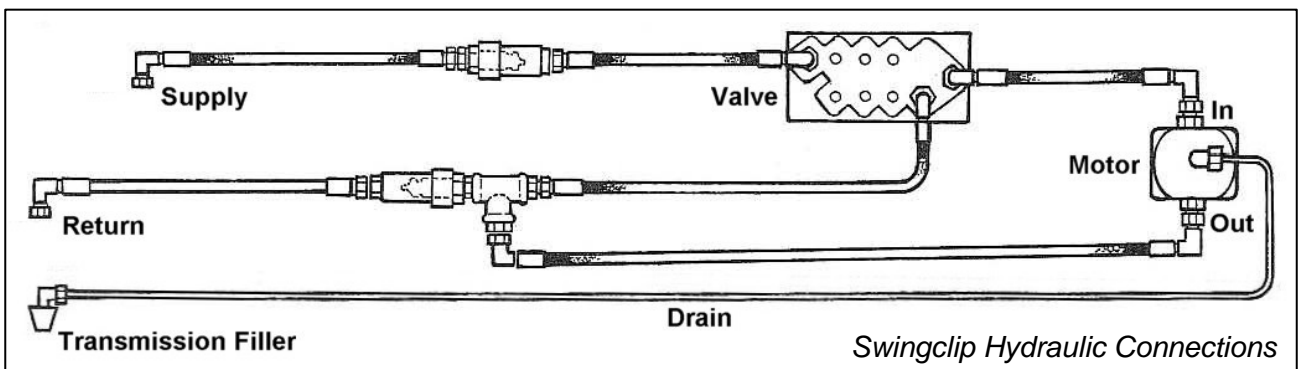



## REMOVAL OF THE MACHINE

---

Removal of the machine from the tractor should always be performed on a firm level site.

### Removal Procedure

- Replace the stand leg in the park position with foot down.
- Position the arms so that the motor is level with the bottom of the frame.
- Disconnect the supply and return hoses plus the motor drain line from the tractor.
- Raise the tractor linkage to take the weight off the yoke. Where a common top link and yoke position is used the yoke must be unbolted in the middle. If different top link location are used the yoke may be unbolted at the top.
- Lower the machine to the ground and disconnect the three point linkage. Remove top halves of the yoke if still attached to tractor.
- Remove control unit from the tractor.

### Storage

Ideally, storage of the machine should be in clean dry location where the machine is protected from the elements.

If the machine is to be left standing for an extended period of time lightly coat the exposed portions of the ram rods with grease. *Note: the grease should be removed and the ram rods wiped clean before the rams are next moved as it will, over a period of time, become contaminated with dust and grit.*

Liberally grease the cutterbar and replace the finger and knife guard. Remember to take care and keep fingers away from the knife.

If the machine is to be stored outside lie a piece of tarpaulin or canvas over the control valve - *do not use a plastic bag as this will promote rapid corrosion of components.*

## OPERATION

### Operation Safety

Before commencing operation of the machine all operator's must read this manual fully paying particular attention to the aspects relating to safe use of the machine. The operator is not only responsible for their own safety but also the safety of all other persons who enter into the close proximity of the working machine.

### Cable Control Operation

Four levers individually control the operating functions of the machine the knobs of which are colour coded according to use.

The function and operational direction of the levers are as follows where ↑ indicates movement of the lever away from the operator and ↓ indicates movement towards the operator:

### Lever Functions

1. Red - ↑ Reach Out and ↓ Reach In.
2. Yellow - ↑ Lift Down and ↓ Lift Up.
3. Green - ↑ Angle C/W and ↓ Angle A-C/W.
4. Black - ↓ Cutterbar On and ↑ Cutterbar Off.

Note: Lever (4) only operates from the central position rearwards, there is no forward travel from the centre position.

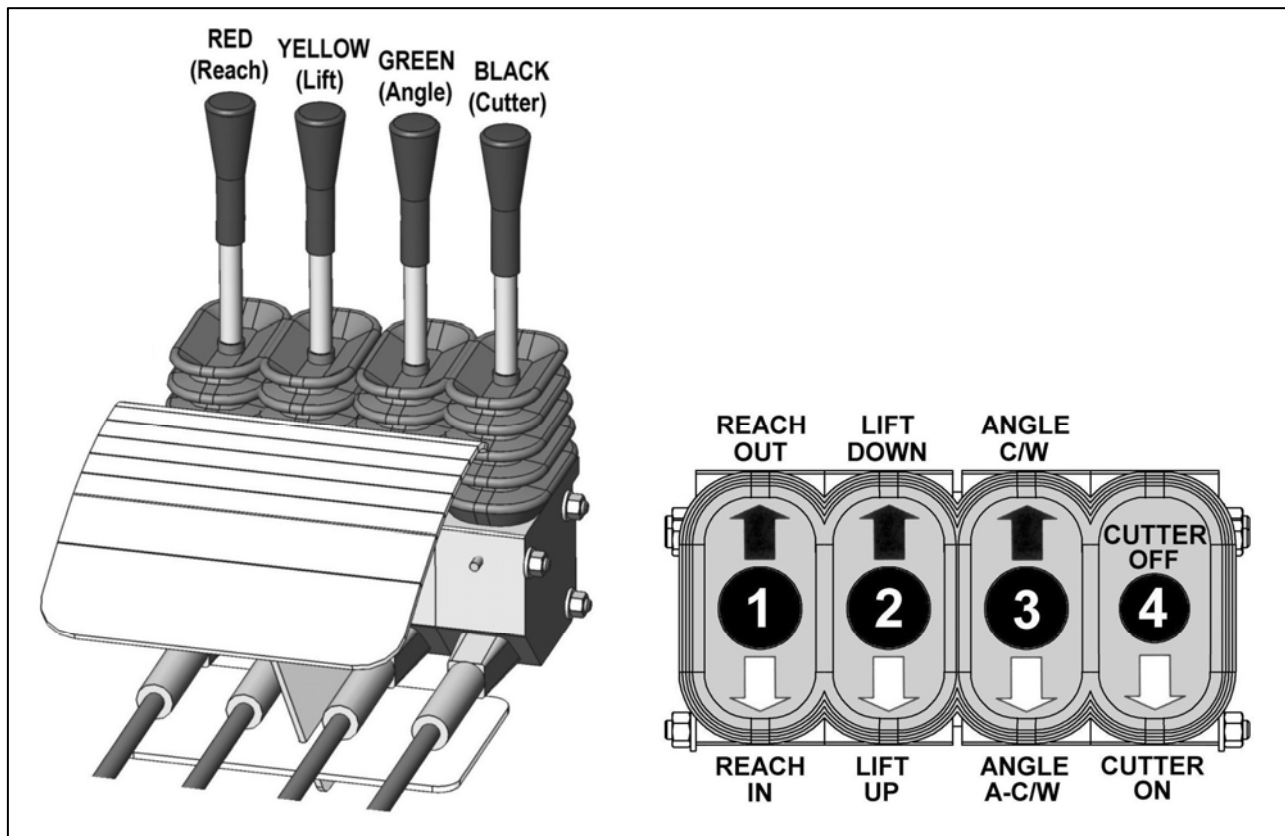

## Proportional Control Operation

On proportional models all operational functions are controlled by a single joystick. With the power switched on via the left hand switch on the control box, forward and rearward operation of the joystick controls Lift Down and Lift Up respectively whilst sideways operation controls Reach In and Reach Out – the particular sideways direction will depend on which side of the tractor the machine is working at the time. Angle function is controlled by rotation of the top of the joystick.

The switch mounted on the left hand side of the control box switches the cutterbar on and off; for safety reasons this switch features a time delay reset to prevent accidental operation of the cutterbar. To start the cutterbar the switch must be held in the forward position for several seconds before switching it to the rearward 'ON' position at which point the cutter will start and the LED light will illuminate. Moving the switch forwards again will switch the cutter 'OFF'.

## Joystick & Switch Functions

1. ⇐ Reach Out and ⇒ Reach In.
  2. ↑ Lift Down and ↓ Lift Up.
  3. C/W - Angle C/W and A-C/W Angle A-C/W.
- A. Power On / Off.  
B. Cutterbar On / Off (Reset).  
C. N/A  
D. N/A

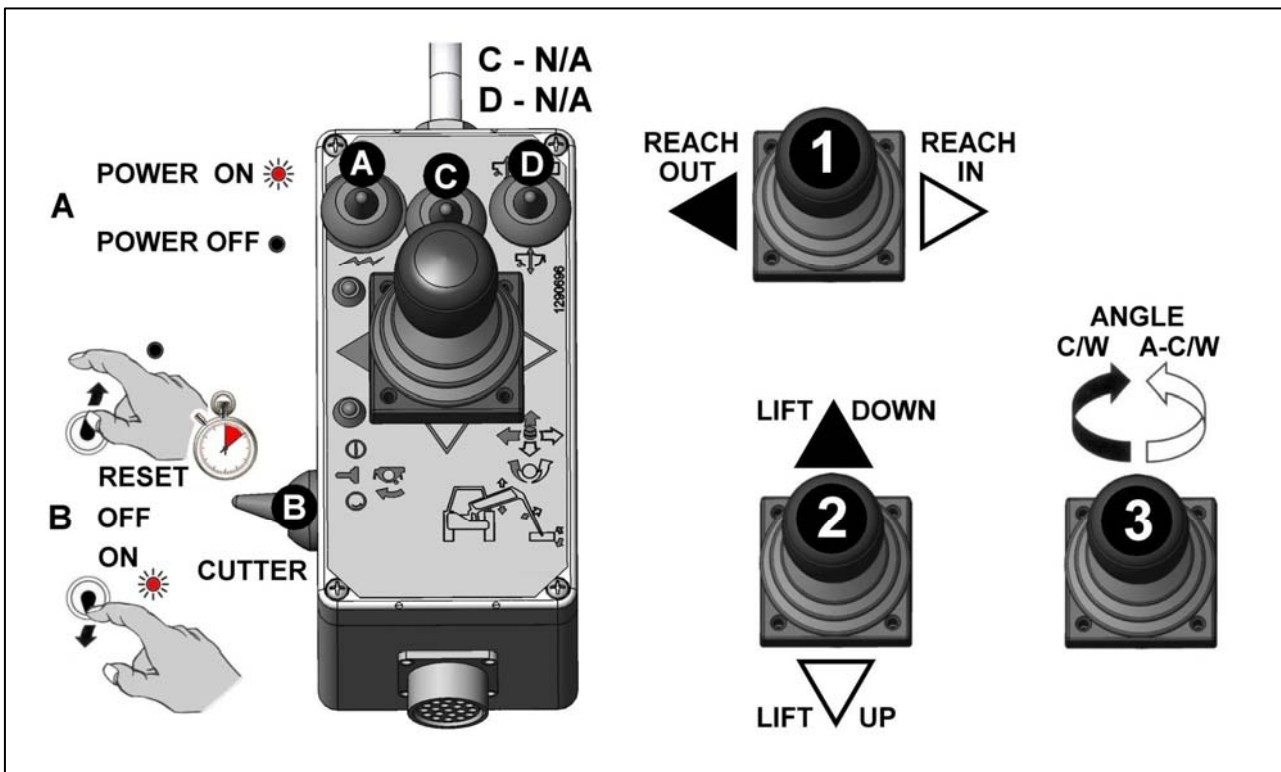

Before commencing work it is advisable to find an unobstructed level site and operate the machine through its entire range of movements to familiarise yourself with the controls and the machines response to them. This is a wise precaution for all operators and a must for the inexperienced.

## Performance and Working Geometry

The Swingclip's 'swingover' feature allows it to be operated on both sides of the tractor without any re-building or operator adjustments. However, to achieve the best cutting action the cutterbar mounting is designed to pitch the knife downwards at eight degrees. This is maintained throughout the operating range except when the cutterbar is pointing upwards during operations on the left hand side. In these positions the knife has to operate with its back to the hedge and therefore some deterioration in the quality of cut can be expected. If it is necessary to carry out a considerable amount of work in these positions the topping performance can be improved by shortening the top link, this will tilt the machine forward thus altering the approach angle of the cutterbar.

The geometry also results in considerably less reach being available for ground cutting on the left hand side.

In addition, be aware that the geometry, depending on the length of draft links and the size of the tractor's wheels may allow the cutterbar to foul the tractor tyres; therefore extra care should be taken when positioning the cutterbar for 'close in' ground cuts. Also check carefully that there is clearance between the arms and the tractor's roll bar/cab before executing the 'swing over' manoeuvre,

The operation of the arms takes priority on the oil flow and may cause the knife to slow down during arm movements. When cutting material which nears the limit of the machines capability avoid adjusting the arm whilst cutting to reduce the likelihood of stalling the knife.

## Swingover Prevention Mechanism

During normal arm movements to either side of the tractor a safety mechanism is employed to prevent the machine from accidentally swinging over to the opposing work side when operating the arms in raised positions.

## Swingover Procedure

To swingover the machine for work on the opposing side 'reach out' should be fully operated to its furthest point then 'lift up' to raise the arms into the upright position, by operating angle the cutterbar can be turned to the opposing side – the transfer of weight and operation of 'lift down' will now permit working on the opposing side.

Wherever possible the swingover procedure should be performed on level ground – if swinging over on sloping ground is absolutely unavoidable always carry out the manoeuvre with the tractor facing directly up the slope.

**WARNING: Never attempt the swingover procedure when facing either across or down a slope.**

## Breakaway Protection

A mechanism is built into the lower mounting points to allow 'breakback' of the machine for protection of components in the event of accidental contact with imovable objects. The sprung mechanism works in conjunction with the lift ram base pin allowing the feature to transfer to the whichever side the machine is operating on.

When encountering an obstruction and the tractor continues to move forward the free suspended link will pivot about its mounting bar and allow the complete armhead and frame to move up and back until the obstruction is cleared or the tractor brought to a halt.

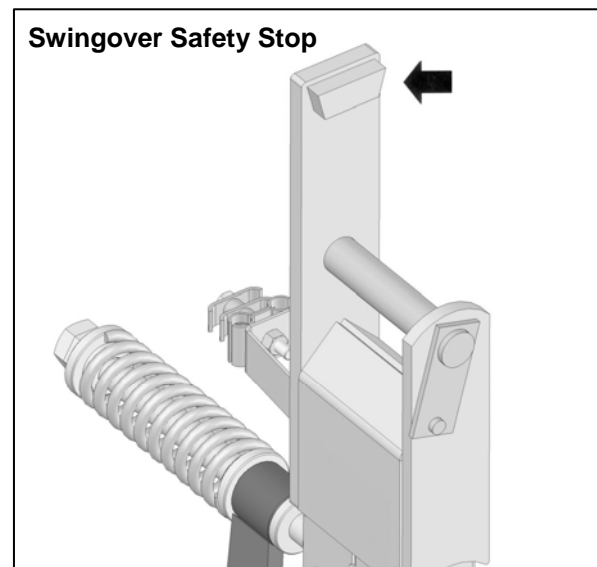

Resetting of the breakaway is completely automatic with the armhead returning to the work position under gravity.

**WARNING:** It is important to understand that this feature is for component protection in unavoidable circumstances only, the breakaway geometry gives limited movement and therefore should not replace the operator's responsibility to avoid potentially damaging situations.

### **Tractor Control Settings**

Refer to the tractor's hand book to ascertain the correct control settings to suit the type of machine and the hydraulic installation.

### **Operational Limitations**

The Swingclip is a light hedge trimming tool - attempting to cut unsuitable material will cause the knife to stall resulting in the tractors relief valve blowing and overheated oil.

### **Tractor Engine Speed**

The tractor engine should be run at a speed which will give 2½ - 4½ gpm (12 - 20 litres) of oil flow to the cutterbar motor. Less will be insufficient to do the work; more will result in increasing cutterbar vibration and greatly accelerated wear.

### **Tractor Forward Speed**

This is a matter for common sense and experience. Forward speed should be set to provide a clean cut.

### **Highway Working**

If it is intended to cut roadside hedges or to work in the vicinity where the public have access, it is a statutory requirement that suitable warning signs are placed at both ends of the work area. These signs should not be more than ½ mile (0.8 km) apart. To further promote highway safety the use of headlamps would be beneficial. Hazard warning lamps should not be used as oncoming vehicles could easily misjudge braking distance in presuming the tractor approaching them is stationary.

### **Cutterbar – Unclogging, Checking or Adjusting**

Before leaving the tractor seat select 'Cutterbar Off', switch off tractor engine and remove the starting key. Should the cutterbar become clogged NEVER, NEVER, NEVER clear any debris from the fingers or knife with your hands - use a stick from the hedge or other suitable tools.

**WARNING:** Always keep fingers away from the knife as the crankshaft fly wheel can move under gravity and activate the knife even though the tractor engine is switched off.

### **Transport**

Operate the arms to fold them into the transport position - see photo opposite.

With the tractor switched off, place the cutterbar guard over the knife remembering to keep your fingers away from the knife as it can move even with the tractor engine switched off.

### **Optional Extras**

Cuttings Tray (Part No. 1090316) bolts to the cutterbar and projects to the rear providing a plate which encourages cuttings to slide off the hedge when topping.



## MAINTENANCE

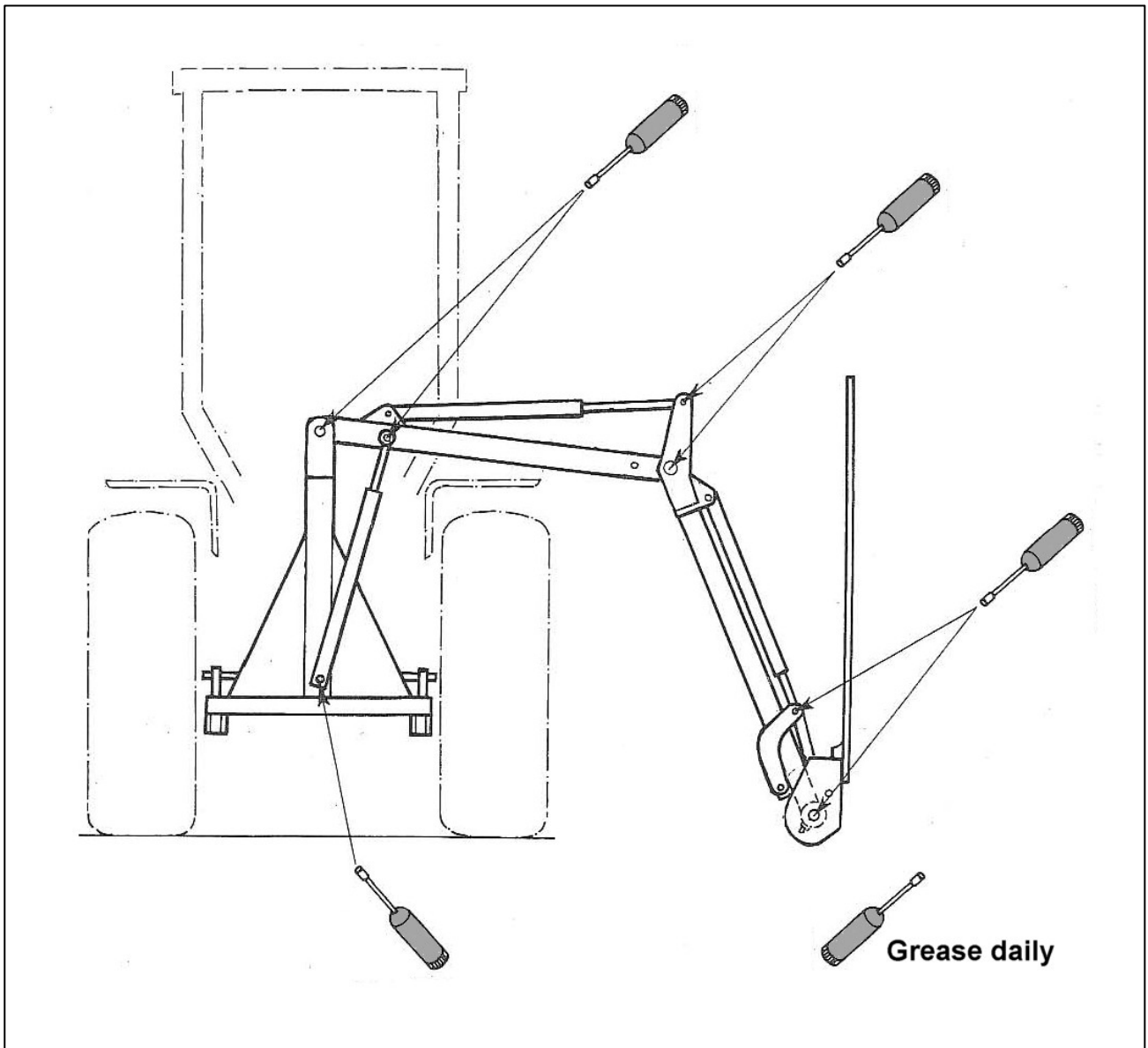

### Lubrication

Refer to the lubrication diagram above and grease daily all points indicated. Remember regular lubrication ensures longer machine life and diminishes service costs. In addition, occasionally oil the con-rod pivots and bushes.

### Fasteners

Check on a daily basis that all bolts and nuts are tight, pins are secure and hydraulic connections are not leaking. Regularly inspect the hydraulic hoses and always replace them immediately at the first signs of wear or damage.

## CUTTERBAR

### Adjusting the Knife Guides

Before commencing any checks or adjustments lay the cutterbar flat on the ground, select cutterbar off', switch off the tractor remove starting key and disconnect the con rod.

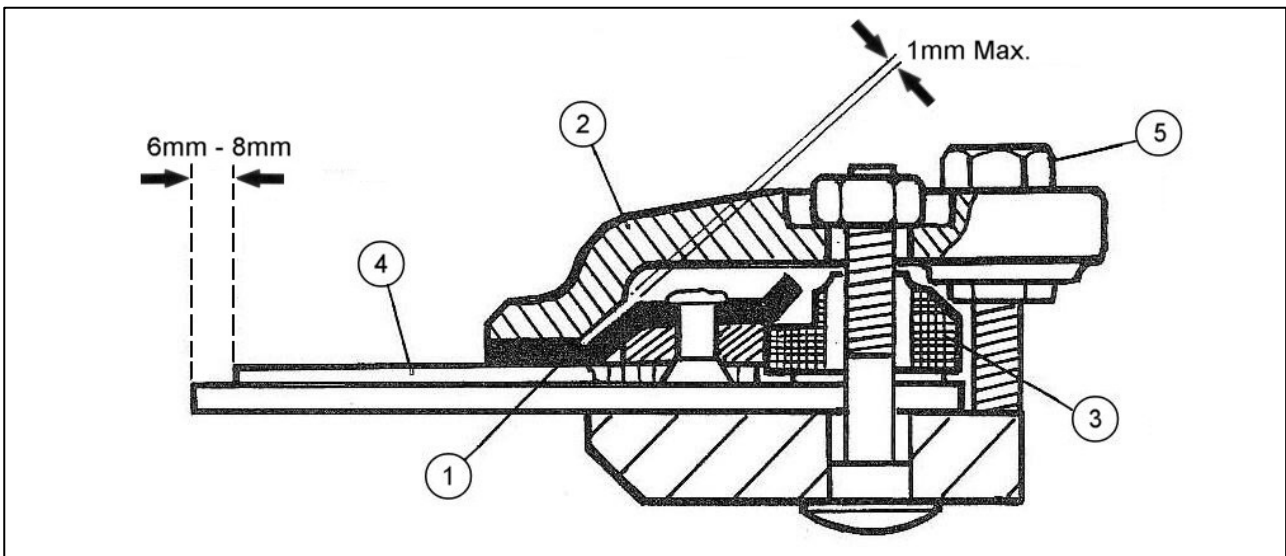

When adjusted correctly the knife sections (4) lie flush between the fingers and the underside of the knife holder (1) with the fingers projecting 6mm to 8mm in front of the knife tips. In addition there must be a maximum clearance of 1mm between the sloping faces of the knife holder (1) and the guide plate (2). This allows clearance for the knife to move freely and can be checked by placing a 5/8" dia bar into the con rod socket in the knife heel and operating by hand.

The guide plate (2) and rubbing plate (3) are mounted through slotted holes which allow the correct lateral positioning of the knife in relation to the fingers.

Any play caused by wear between the knife holder (1) and the knife sections (4) is removed by turning the setscrew (5). The knife guide should be adjusted until the mating faces are flush. No downward pressure should be exerted onto the knife as this may impede its free movement.

### Sharpening the knife

After five to twenty operating hours, depending on the work involved, the knives require re-sharpening. It is recommended that the knives be removed from the cutterbar for resharping. The procedure is as follows:

Switch off tractor and remove the starting key.

- Disconnect the con rod, remove the three setscrews securing the knife heel to the knife and withdraw the knife from the cutterbar.
- Clean the knife and ensure that neither the back nor the knife sections are bent – if required, straighten as necessary.  
A cutting angle of 35°- 40° is required.

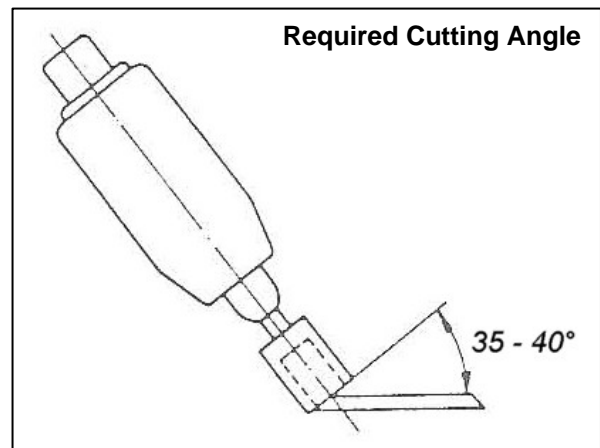

A high speed hand grinder should be used, with ideally, a pot shaped pencil grinder of approximately 1" (25mm) diameter by 1 3/8" (35mm) long. Grinding is carried out with the end face of the grinder moving from the base of the knife section up to the points.

It is possible to re-sharpen the knives in situ, the procedure is as follows:

Position the cutterbar on or parallel to the ground. Switch off the tractor engine and disconnect the con-rod. Manually position the knives so that they cover the fingers and clamp together in this position.

Sharpening with files is not recommended as the process tends to leave small burrs on the edge which curl under when the knife is replaced thus impeding the free movement of the knife and leaving a blunt cutting edge.

**DANGER:** It is imperative that great care is adopted at all times when working with the cutterbar to avoid injury – the use of safety gloves and safety glasses is recommended at all times when working with this and all associated components.

### Hydraulic Pump Connections for Correct Crankshaft Direction

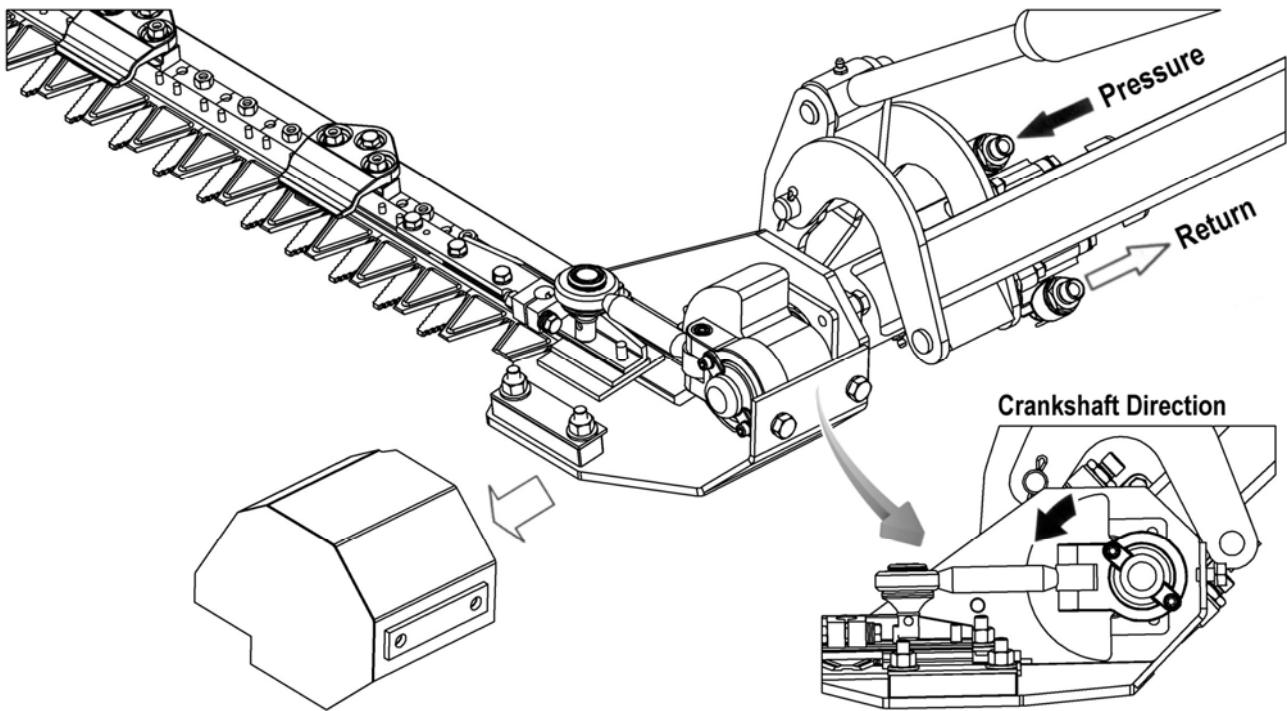



## HYDRAULIC RAMS

---

### **General Information**

Whenever possible maintenance work on the rams should be performed with the ram removed from the machine and thoroughly cleaned off prior to dismantling on a clean work bench.

When using a bench vice do not apply excessive pressure to the ram cylinder - use soft metal jaws when grasping the ram rod. Scores and nicks on the ram rod should be removed using a fine oil stone - never use a file or emery cloth as these are too abrasive and will damage the ram rods working surface.

### **Seal Replacement – Standard Ø40mm Reach, Angle & Lift Rams**

To change the seals on the angle, reach and Ø40mm lift rams the following procedure applies:

- Unscrew the gland and withdraw the complete rod assembly.
- Remove piston locking nut and slide the piston and gland housing off the rod.
- Lubricate all new seals prior to assembly.
- Replace gland seals ensuring they are positioned in exactly the same location from which they were removed.
- Carefully place the gland housing complete with seals back on the rod.
- Separate the piston halves and discard rod seals. Rebuild the piston onto the rod fitting a new piston rod 'O' ring.
- The piston seals can be replaced in conjunction with the above operation or alternatively, gently prised into position after the piston and locking nut are reassembled.
- Refit the piston locking nut using 'Permabond A713' or a similar medium strength thread locking compound.
- Reassemble the complete rod into the ram cylinder, screw in gland housing and tighten.

### **Seal Replacement – Alternative Ø50mm Lift Ram**

To change the seals on a Ø50mm lift ram the following procedure applies:

- Unscrew the gland and withdraw the complete rod assembly.
- Slacken piston grub screw, unscrew the piston and slide off the gland housing.
- Replace gland seals as necessary. Ensure seals are replaced in the same position from which they were removed.
- Remove split members of the piston seal and then, using a soft lever which will not scratch the piston, lift the remaining seal components from the piston.
- Replace with new seals in reverse order.
- Refit gland housing on the rod taking care when easing the wiper seal over the piston rod shoulder.

The piston is locked onto the rod with a medium strength thread locking fluid such as 'Permabond A 113', 'Loctite Nutloc 242', 'Dunlop Nutloc SAS101', 'Tru lock Nutgrade 375' or 'Hermetite Torqueseal M'.

Threads must be cleaned with a suitable solvent to remove oil and thoroughly dried before applying a complete film of the locking fluid to the rod threads. The piston should be screwed on, tightened firmly and left for 30 minutes before filling with oil and 60 minutes before pressurising.

## HYDRAULIC SYSTEM (Machines Equipped with Pump and Tank Kit)

### Oil Requirements

#### Tank

The machine is delivered from the factory without oil. Fill the reservoir with a light hydraulic oil as recommended in the chart below until the oil level is approximately 2" below the top of the tank. The total capacity is approximately 23 litres (5 galls) **Do not overfill.**

For ease of filling when large quantities are involved the strainer basket can be prised from its housing. If filling in this manner make sure that new oil is used and that the area around filler and any filling utensils are clean.

SUPPLIER	COLD OR TEMPERATE CLIMATE	HOT CLIMATE
BP	<i>Bartran 46</i> <i>Energol HLP-HM 46</i>	<i>Bartran 68</i> <i>Energol HLP-HM 68</i>
CASTROL	<i>Hyspin AWH-M 46</i>	<i>Hyspin AWH-M 68</i>
COMMA	<i>Hydraulic Oil LIC 15</i>	<i>Hydraulic Oil LIC 20</i>
ELF	<i>Hydrelf HV 46</i> <i>Hydrelf XV 46</i>	<i>Hydrelf HV 68</i>
ESSO	<i>Univis N 46</i>	<i>Univis N 68</i>
FUCHS (UK/Non UK markets*)	<i>Renolin 46</i> <i>Renolin HVZ 46</i> <i>Renolin CL46/B15*</i> <i>Renolin AF46/ZAF46B*</i>	<i>Renolin 68</i> <i>Renolin HVZ 68</i> <i>Renolin CL68/B20*</i> <i>Renolin AF68/ZAF68B*</i>
GREENWAY	<i>Excelpower HY 68</i>	<i>Excelpower HY 68</i>
MILLERS	<i>Millmax 46</i> <i>Millmax HV 46</i>	<i>Millmax 68</i> <i>Millmax HV 68</i>
MORRIS	<i>Liquimatic 5</i> <i>Liquimatic HV 46</i> <i>Triad 46</i>	<i>Liquimatic 6</i> <i>Liquimatic HV 68</i> <i>Triad 68</i>
SHELL	<i>Tellus 46</i> <i>Tellus T46</i>	<i>Tellus 68</i> <i>Tellus T68</i>
TEXACO	<i>Rando HD 46</i> <i>Rando HDZ 46</i>	<i>Rando HD 68</i> <i>Rando HDZ 68</i>
TOTAL	<i>Equivis ZS 46</i>	<i>Equivis ZS 68</i>

#### Oil supply

Check daily the oil level in the reservoir.

No fixed time period can be quoted for oil changes as operating conditions and maintenance standards vary so widely. Although the oil does not wear out, it does eventually break down through contamination, oxidation and condensation. Continual operation of the machine beyond its rated capacity to almost the stall point of the cutter can cause overheating which produces insoluble gums, sludge, varnish and acids. Overheated oil thins to give a sluggish performance and causes earlier failure of seals and 'O' rings. Burnt and scorched oil odours and the oil darkening and thickening are all signs of oxidation and indicate the oil should be changed.

Moisture which results from condensation can become entrapped in the oil and cannot be removed by filtration so that contamination is a progressive factor.

Contamination of the oil can be reduced by:

- Performing all hydraulic servicing in a clean, dry, dust-free environment.
- Cleaning around the reservoir cap prior to its removal and keeping that area clean.
- Using clean containers when replenishing the system.
- Regular servicing of the filtration system.

## Filtration Maintenance

The machine is protected by a low pressure 10 micron full flow return line filter.

### Return Line Filter

The element should be changed after the first 50 hours of use and thereafter at 500 hour intervals. It is important to note hours worked as if the the filter becomes blocked an internal by-pass within the canister will operate and no symotons of filter malfunction will occur to jog your memory.

### Hydraulic Pumps

A hydraulic pump complete with drive coupler is used with all machines with independent hydraulics.

No routine maintenance is necessary on the pumps other than a periodical check for tightness of the mounting bolts and a visual check for oil leakage, especially around the pump supply and pressure unions. Two hose clips are used on the pump supply hose and their worm-drive barrels should be placed opposing each other at 180°. These clips should regularly be checked for tightness, especially during the first few hours of work, to avoid the possibility of air being drawn into the hydraulic system.

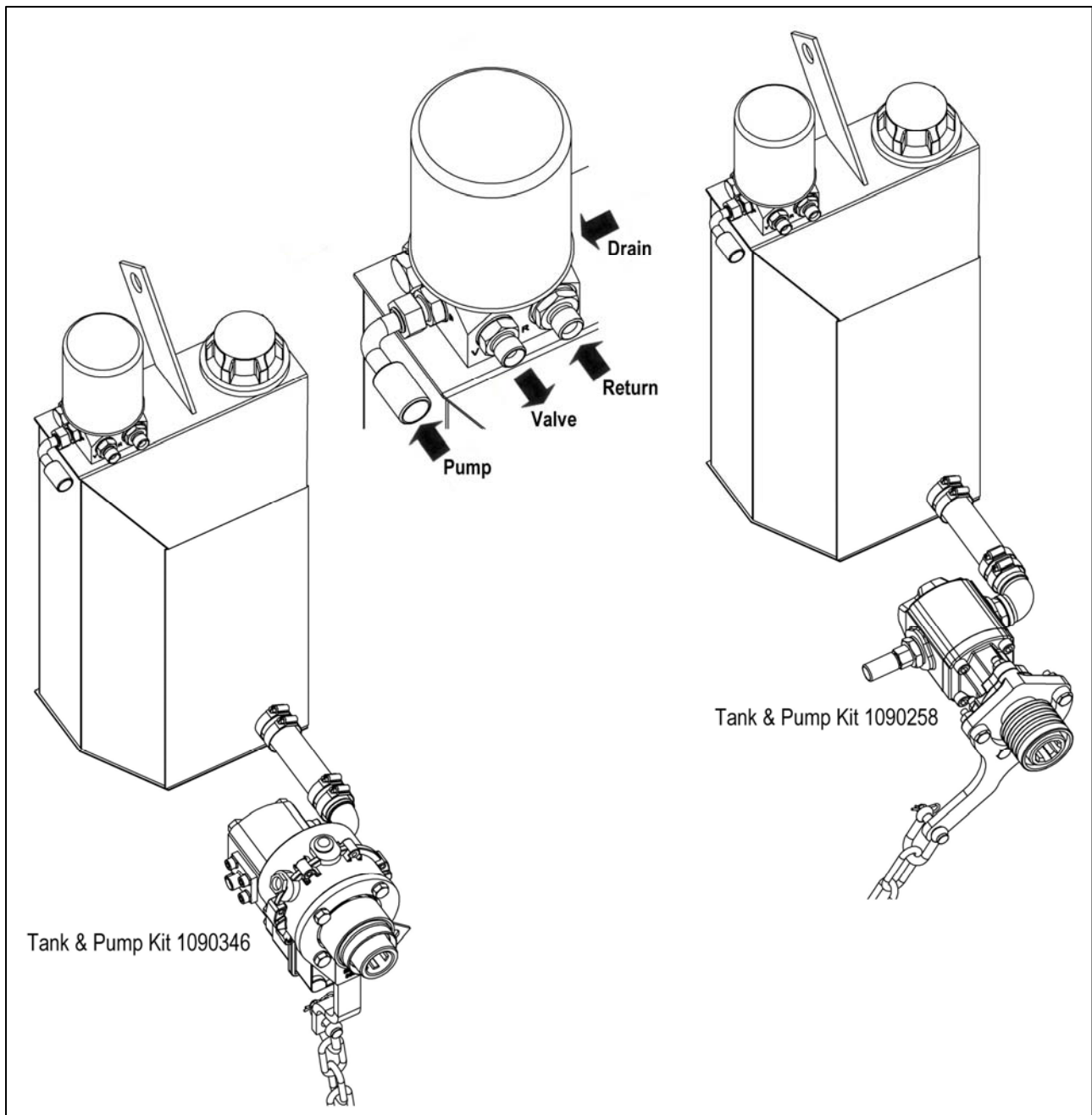

# CONTROL VALVE

**IMPORTANT:** Any service or maintenance work on hydraulic components must always be performed in a clean dry dust free environment to avoid risk of contamination or damage.

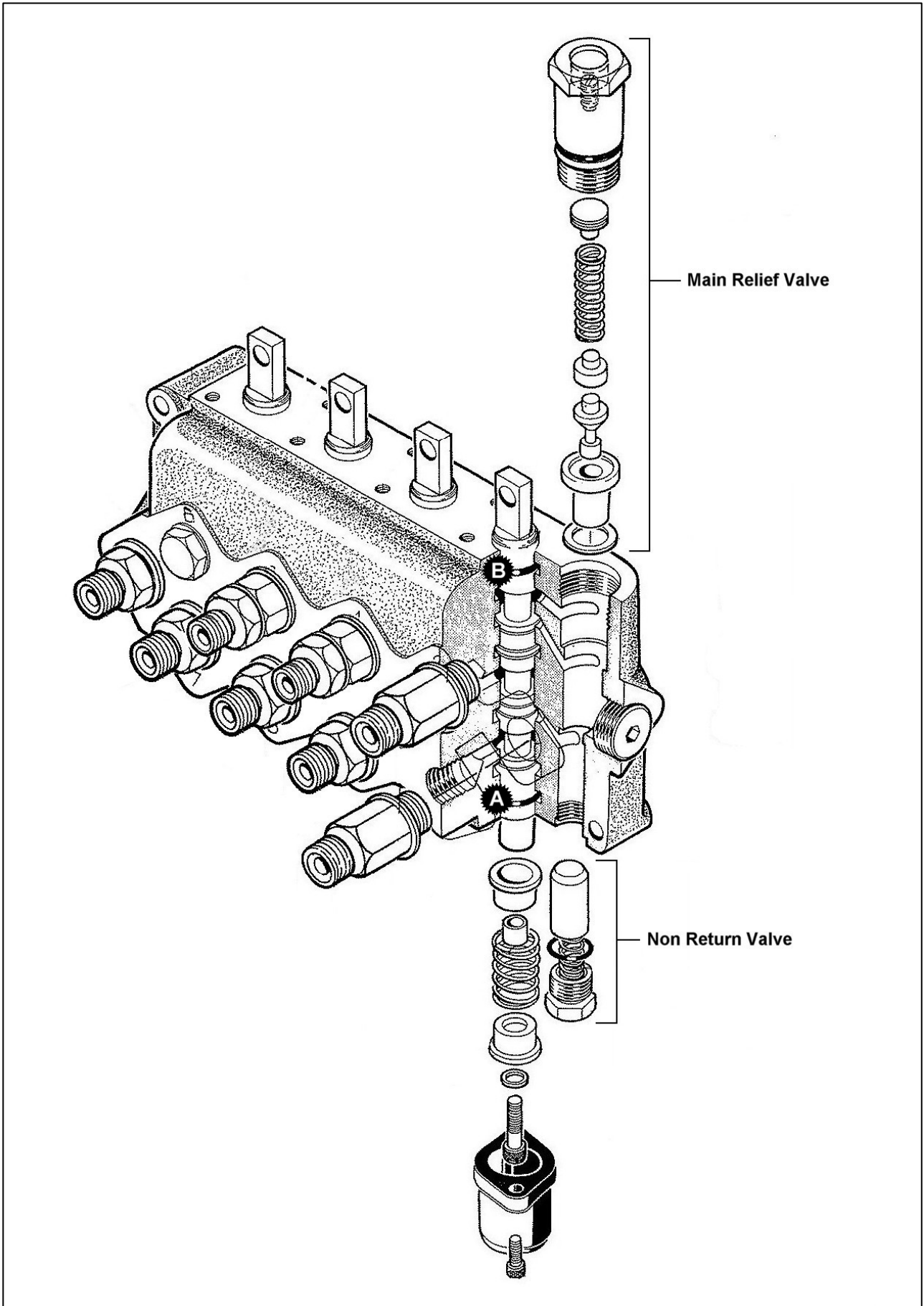

## Non Return Valve

The non return valve prevents the feedback of oil from the service ports. It is unlikely to need attention but if removed for cleaning a new 'O' Ring should be used when refitting.

## Replacing Spool 'O' Rings

Note: Owing to the sharp edges in the design of the spool failure to carry out the following procedure could result in damage to the 'O' rings resulting in external leakage.

- Disconnect cable assembly.
- Remove the cover at the opposite end of the spool and unscrew the return spring or detent assembly whichever is necessary.
- Pull the spool through the block from the handle end until the 'O' ring marked 'A' is accessible - remove the 'O' ring from its groove using a smooth edged hook.
- Completely remove the spool from the block out of the return spring end.
- Remove the 'O' ring marked 'B' and refit the new 'O' ring.
- Lightly oil the spool and replace it in the block from the return spring end pushing it through far enough to clear the 'O' ring groove 'A'.
- Fit new 'O' ring in groove 'A'.
- Push the spool back through from the handle end far enough to re-assemble the return spring or detent assembly plus the cover.
- Attach cable assembly.

## Main Relief Valve

The main relief valve is pressure set at the factory to 1450 PSI (100Bar) and is non adjustable. A sticking relief valve will probably cause overheating and/or loss of power. If this is suspected it should be dismantled and examined for dirt and damage. Undo the large hexagon housing, the relief valve spring, needle and seat can now be withdrawn. If difficulty is experienced in extracting the seat remove the non-return valve at the opposite end of the gallery and drive out with a soft brass drift - *take care not to damage the copper sealing washer positioned between the seat and the locating shoulder in the block.*

Blow out the valve with compressed air and examine the components for damage. These components are specially hardened steel and should only display a seating witness - any further damage will require the complete valve to be replaced.

**CAUTION: Under no circumstances be tempted to add shims into this valve in a misguided attempt to increase the power of the machine. This could damage the tractor and may cause personal injury.**

## HYDRAULIC HOSES

The condition of all hoses should be checked during routine servicing. Damaged hoses should be replaced immediately.

### Hose Replacement

Always replace one hose at a time to avoid the risk of wrong connections. It is always advisable to run the new replacement hose alongside the old one prior to removal – this will determine the correct hose path and avoid possible damage caused by incorrect hose routing.

Where a hose is attached to an additional fitting or union, use a second spanner on the union to avoid breaking both seals.

Never use jointing compound on threads.

Avoid twisting hoses and adjust the hose line to ensure freedom from rubbing or trapping before tightening the hose end connections.

### Hose Warranty

Warranty is limited to replacement of hoses that have failed due to faulty manufacture or materials. Warranty will not be considered on hoses that have suffered damage by abrasion, cuts or being pinched or trapped while in work. A claim will not be considered where the hose end has been damaged by a blow or where the threads or unions have been damaged by overtightening.

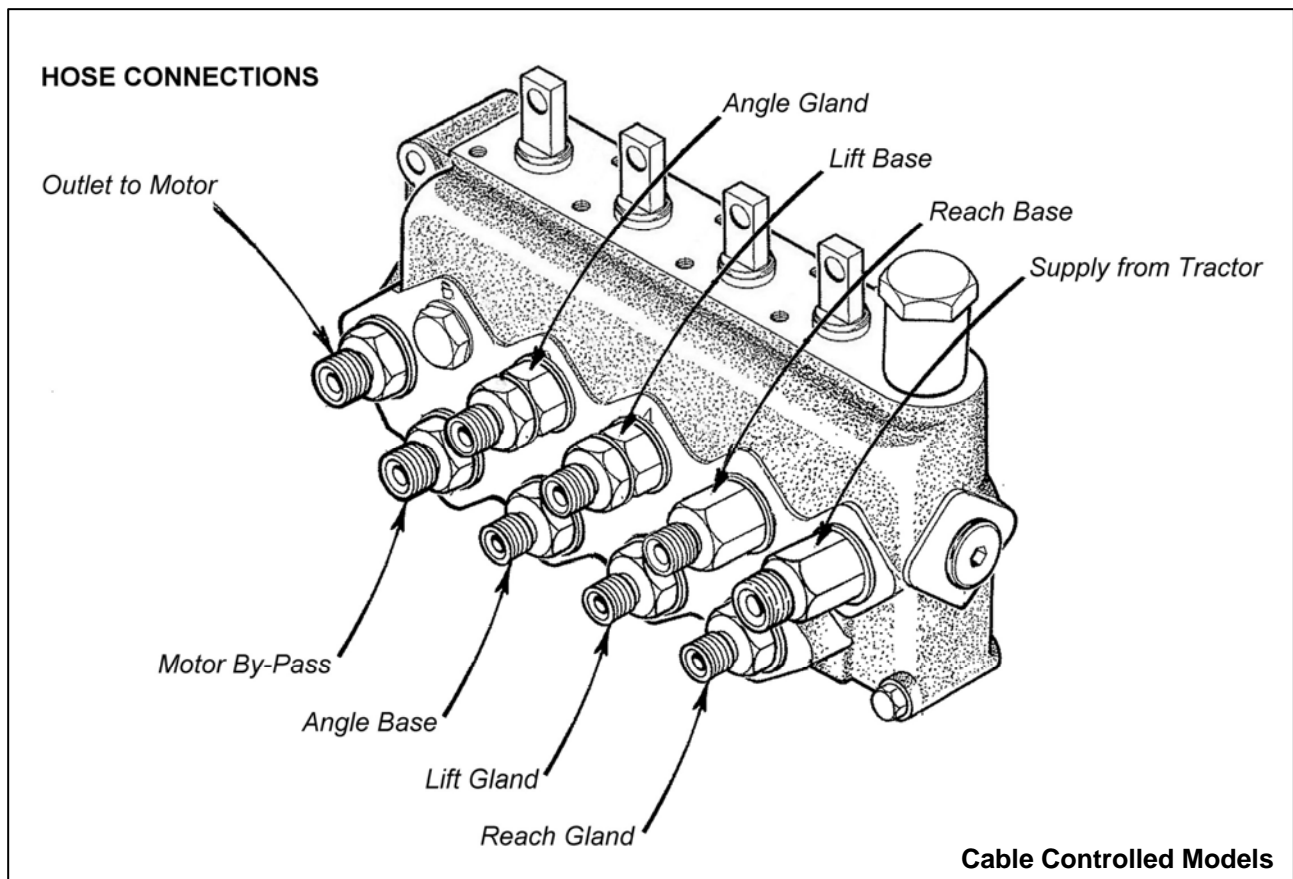

## PUMP AND TANK KIT

---

### Minimum Requirement

A minimum distance of 550mm must be available between the attachment point of the machine and the rear of the tractor's PTO output shaft for fitment of a Pump & Tank Kit.

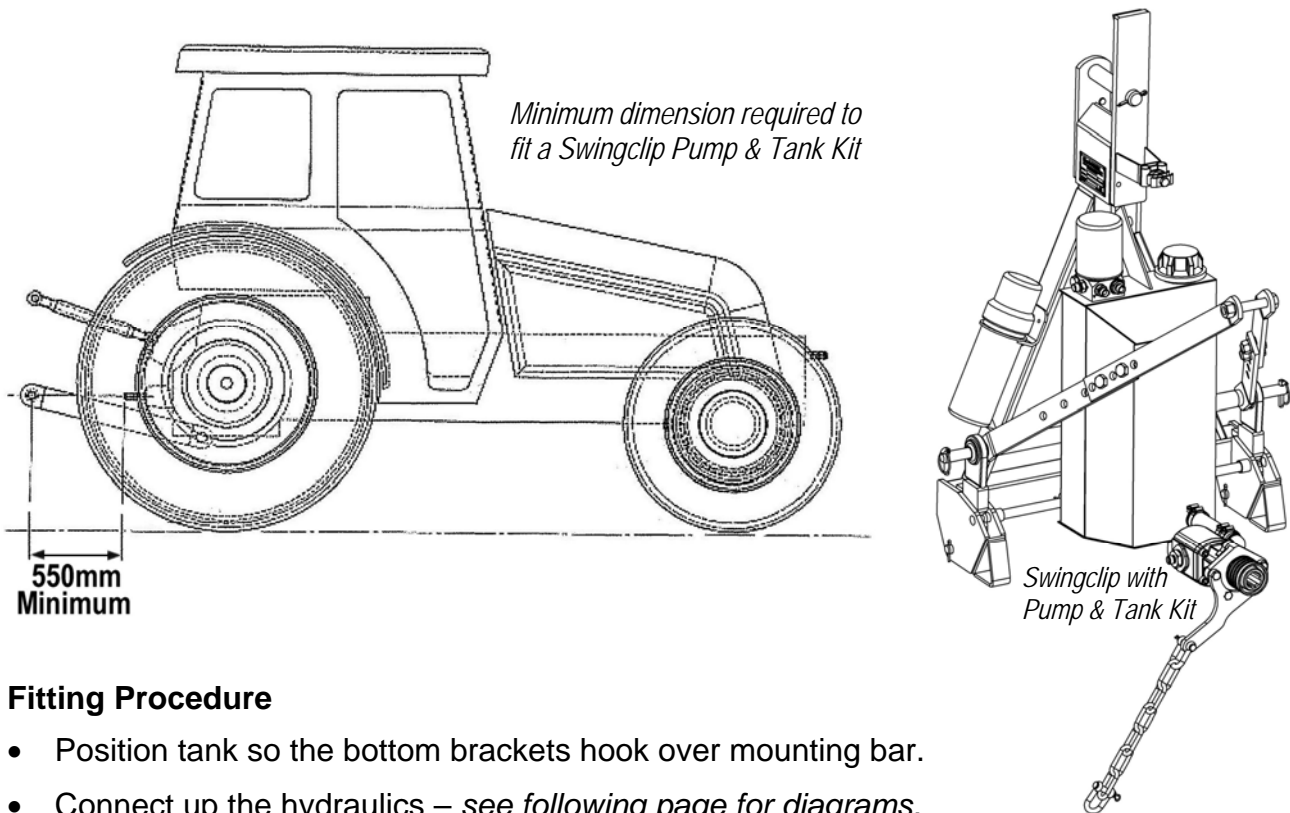

### Fitting Procedure

- Position tank so the bottom brackets hook over mounting bar.
- Connect up the hydraulics – see *following page for diagrams*.
- Reverse tractor squarely up to the machine.
- Connect Pump and drive assembly to PTO shaft on tractor.
- Secure the torque chain so the angle is approximately 90° to the torque arm in lateral alignment.
- Connect machine to tractor – refer to *attachment to tractor section*.
- Fit top link pin through top bracket of tank and flange on main frame.
- Adjust top link to bring main frame vertical.
- Tighten the nut to secure the upper yoke just enough to eliminate any sideways movement - *do not over tighten and 'squeeze' the top hitch brackets*.
- Tighten the check chains/stabiliser bars.
- Fit controls to tractor mounting bracket.
- Fill reservoir with required oil (*refer to recommended oils chart*).
- Turn the parking leg upside down and pin in the work position.

Start tractor and engage PTO drive - allow the pump to work under a 'no load' condition i.e. with operating controls in neutral, for several minutes with tractor engine at a high idle. Operate the machine through its complete range of movements including operation of the cutterbar drive - check the reservoir and top up if necessary.

Before commencing work it is advisable to find an unobstructed level site and operate the machine through its entire range of movements to familiarise yourself with the controls and the machines response to them.

## Pump and Tank Kit – Hydraulic Installations

The diagrams below show the hydraulic installations for the Swingclip pump and tank kits.

### Cable Machines

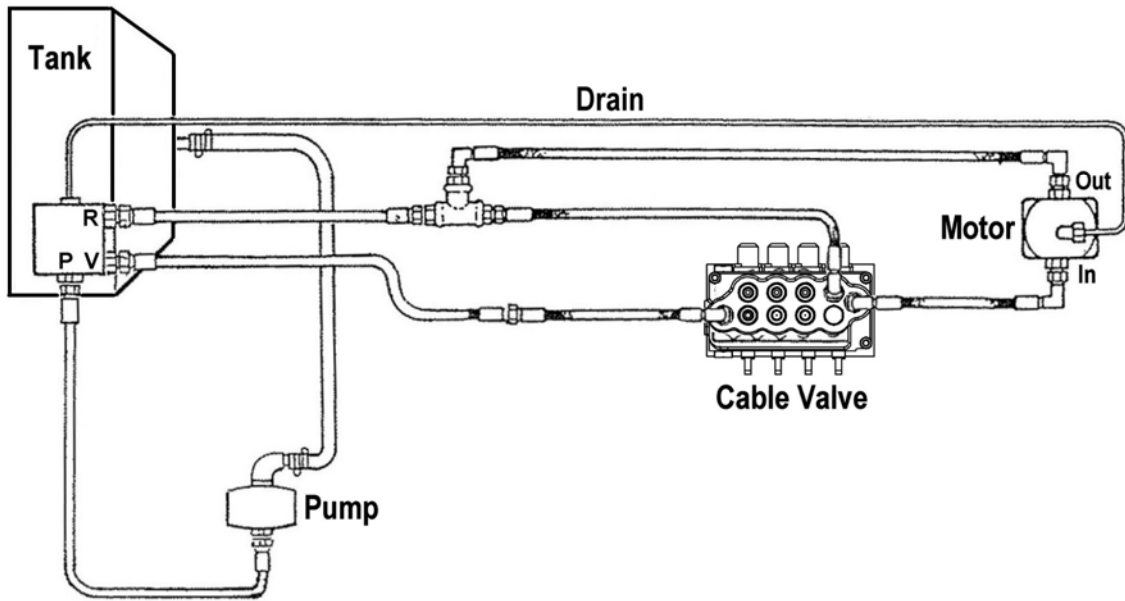

### Proportional Machines

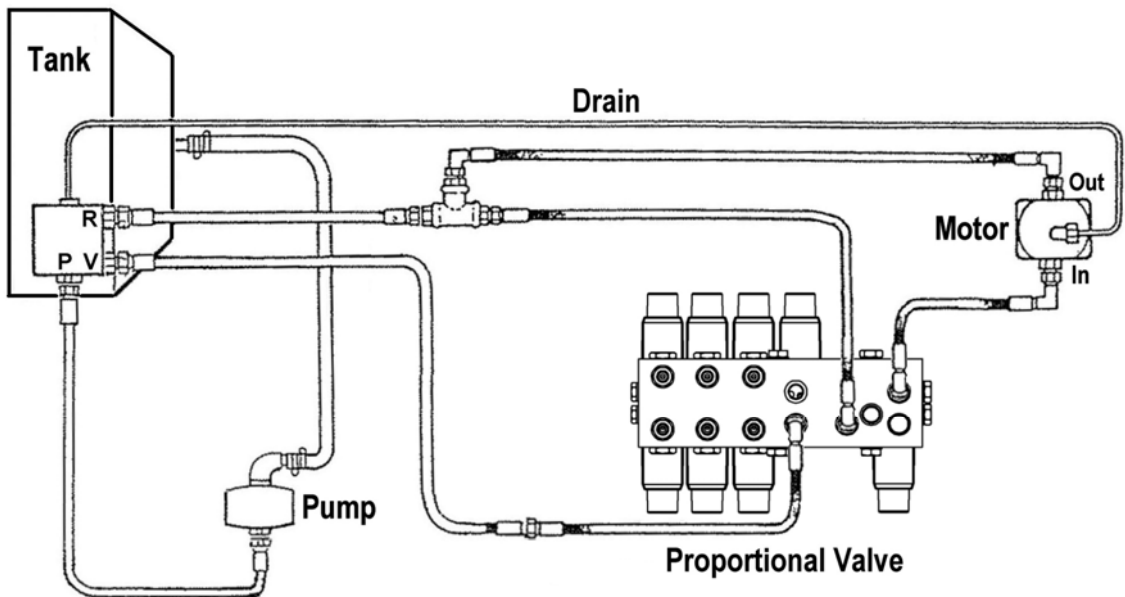



# PROPORTIONAL VALVE – Wiring Installation & Hose Connections

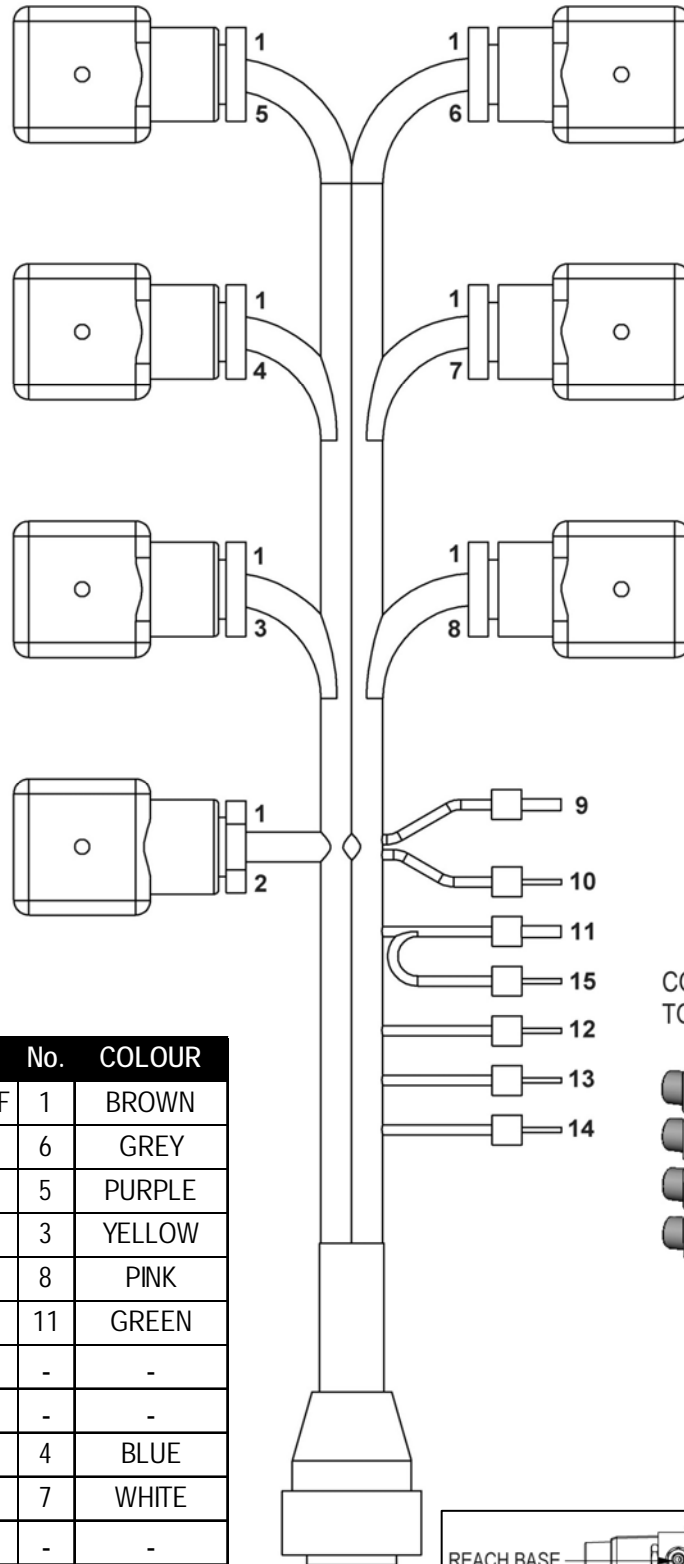

CONNECT MOTOR CONTROL TO WIRES 12 & 14

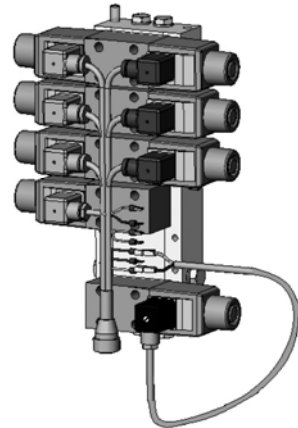

IDENT.	FUNCTION	No.	COLOUR
A	COMMON + C.OFF	1	BROWN
B	REACH IN	6	GREY
C	REACH OUT	5	PURPLE
D	LIFT UP	3	YELLOW
E	LIFT DOWN	8	PINK
F	COMMON	11	GREEN
G	-	-	-
H	-	-	-
J	ANGLE DOWN	4	BLUE
K	ANGLE UP	7	WHITE
L	-	-	-
M	COMMON	15	GREEN
N	COMMON	14	LIGHT
P	ANGLE FLOAT	9	RED/BLUE
R	FLOAT OPTION	10	RED/WHITE
S	PUMP 1	12	BLACK
T	PUMP 2	13	ORANGE
V	CUT OFF	2	RED

