



Twose Series

3 GANG CAMBRIDGE ROLLERS

Models: 640, 730 & 820

OPERATOR MANUAL

Publication 5296

May 2016

IMPORTANT

VERIFICATION OF WARRANTY REGISTRATION



DEALER WARRANTY INFORMATION & REGISTRATION VERIFICATION

It is imperative that the selling dealer registers this machine with McConnel Limited before delivery to the end user – failure to do so may affect the validity of the machine warranty.

To register machines go to the McConnel Limited web site at www.mccommel.com, log onto 'Dealer Inside' and select the 'Machine Registration button' which can be found in the Service Section of the site. Confirm to the customer that the machine has been registered in the section below.

Should you experience any problems registering a machine in this manner please contact the McConnel Service Department on 01584 875848.

Registration Verification

Dealer Name:
Dealer Address:
Customer Name:
Date of Warranty Registration:/...../..... Dealer Signature:

NOTE TO CUSTOMER / OWNER

Please ensure that the above section above has been completed and signed by the selling dealer to verify that your machine has been registered with McConnel Limited.

IMPORTANT: During the initial 'bedding in' period of a new machine it is the customer's responsibility to regularly inspect all nuts, bolts and hose connections for tightness and re-tighten if required. New hydraulic connections occasionally weep small amounts of oil as the seals and joints settle in – where this occurs it can be cured by re-tightening the connection – *refer to torque settings chart below*. The tasks stated above should be performed on an hourly basis during the first day of work and at least daily thereafter as part of the machines general maintenance procedure.

CAUTION: DO NOT OVER TORQUE HYDRAULIC FITTINGS AND HOSES

TORQUE SETTINGS FOR HYDRAULIC FITTINGS

HYDRAULIC HOSE ENDS		
BSP	Setting	Metric
1/4"	18 Nm	19 mm
3/8"	31 Nm	22 mm
1/2"	49 Nm	27 mm
5/8"	60 Nm	30 mm
3/4"	80 Nm	32 mm
1"	125 Nm	41 mm
1.1/4"	190 Nm	50 mm
1.1/2"	250 Nm	55 mm
2"	420 Nm	70 mm

PORT ADAPTORS WITH BONDED SEALS		
BSP	Setting	Metric
1/4"	34 Nm	19 mm
3/8"	47 Nm	22 mm
1/2"	102 Nm	27 mm
5/8"	122 Nm	30 mm
3/4"	149 Nm	32 mm
1"	203 Nm	41 mm
1.1/4"	305 Nm	50 mm
1.1/2"	305 Nm	55 mm
2"	400 Nm	70 mm

WARRANTY POLICY

WARRANTY REGISTRATION

All machines must be registered, by the selling dealer with McConnel Ltd, before delivery to the end user. On receipt of the goods it is the buyer's responsibility to check that the Verification of Warranty Registration in the Operator's Manual has been completed by the selling dealer.

1. LIMITED WARRANTIES

- 1.01. *All machines supplied by McConnel Ltd are warranted to be free from defects in material and workmanship from the date of sale to the original purchaser for a period of 12 months, unless a different period is specified.*
- 1.02. *All spare parts supplied by McConnel Ltd and purchased by the end user are warranted to be free from defects in material and workmanship from the date of sale to the original purchaser for a period of 6 months. All parts warranty claims must be supported by a copy of the failed part invoice to the end user. We cannot consider claims for which sales invoices are not available.*
- 1.03. *The warranty offered by McConnel Ltd is limited to the making good by repair or replacement for the purchaser any part or parts found, upon examination at its factory, to be defective under normal use and service due to defects in material or workmanship. Returned parts must be complete and unexamined. Pack the component(s) carefully so that any transit damage is avoided. All ports on hydraulic items should be drained of oil and securely plugged to prevent seepage and foreign body ingress. Certain other components, electrical items for example, may require particular care when packing to avoid damage in transit.*
- 1.04. *This warranty does not extend to any product from which McConnel Ltd's serial number plate has been removed or altered.*
- 1.05. *This warranty does not apply to any part of the goods, which has been subjected to improper or abnormal use, negligence, alteration, modification, fitment of non-genuine parts, accident damage, or damage resulting from contact with overhead power lines, damage caused by foreign objects (e.g. stones, iron, material other than vegetation), failure due to lack of maintenance, use of incorrect oil or lubricants, contamination of the oil, or which has served its normal life. This warranty does not apply to any expendable items such as blades, belts, clutch linings, filter elements, flails, flap kits, skids, soil engaging parts, shields, guards, wear pads, pneumatic tyres or tracks.*
- 1.06. *Temporary repairs and consequential loss - i.e. oil, downtime and associated parts are specifically excluded from the warranty.*
- 1.07. *Warranty on hoses is limited to 12 months and does not include hoses which have suffered external damage. Only complete hoses may be returned under warranty, any which have been cut or repaired will be rejected.*
- 1.08. *Machines must be repaired immediately a problem arises. Continued use of the machine after a problem has occurred can result in further component failures, for which McConnel Ltd cannot be held liable, and may have safety implications.*
- 1.09. *If in exceptional circumstances a non McConnel Ltd part is used to effect a repair, warranty reimbursement will be at no more than McConnel Ltd's standard dealer cost for the genuine part.*
- 1.10. *Except as provided herein, no employee, agent, dealer or other person is authorised to give any warranties of any nature on behalf of McConnel Ltd.*
- 1.11. *For machine warranty periods in excess of 12 months the following additional exclusions shall apply:*
 - 1.11.1. *Hoses, exposed pipes and hydraulic tank breathers.*
 - 1.11.2. *Filters.*
 - 1.11.3. *Rubber mountings.*
 - 1.11.4. *External electric wiring.*
 - 1.11.5. *Bearings and seals.*

- 1.12. *All service work, particularly filter changes, must be carried out in accordance with the manufacturer's service schedule. Failure to comply will invalidate the warranty. In the event of a claim, proof of the service work being carried out may be required.*
- 1.13. *Repeat or additional repairs resulting from incorrect diagnosis or poor quality previous repair work are excluded from warranty.*

NB Warranty cover will be invalid if any non-genuine parts have been fitted or used. Use of non-genuine parts may seriously affect the machine's performance and safety. McConnel Ltd cannot be held responsible for any failures or safety implications that arise due to the use of non-genuine parts.

2. REMEDIES AND PROCEDURES

- 2.01. *The warranty is not effective unless the Selling Dealer registers the machine, via the McConnel Ltd web site and confirms the registration to the purchaser by completing the confirmation form in the operator's manual.*
- 2.02. *Any fault must be reported to an authorised McConnel Ltd dealer as soon as it occurs. Continued use of a machine, after a fault has occurred, can result in further component failure for which McConnel Ltd cannot be held liable.*
- 2.03. *Repairs should be undertaken within two days of the failure. Claims submitted for repairs undertaken more than 2 weeks after a failure has occurred, or 2 days after the parts were supplied will be rejected, unless the delay has been authorised by McConnel Ltd. Please note that failure by the customer to release the machine for repair will not be accepted as a reason for delay in repair or submitting warranty claims.*
- 2.04. *All claims must be submitted, by an authorised McConnel Ltd Service Dealer, within 30 days of the date of repair.*
- 2.05. *Following examination of the claim and parts, McConnel Ltd will pay, at their discretion, for any valid claim the invoiced cost of any parts supplied by McConnel Ltd and appropriate labour and mileage allowances if applicable.*
- 2.06. *The submission of a claim is not a guarantee of payment.*
- 2.07. *Any decision reached by McConnel Ltd is final.*

3. LIMITATION OF LIABILITY

- 3.01. *McConnel Ltd disclaims any express (except as set forth herein) and implied warranties with respect to the goods including, but not limited to, merchantability and fitness for a particular purpose.*
- 3.02. *McConnel Ltd makes no warranty as to the design, capability, capacity or suitability for use of the goods.*
- 3.03. *Except as provided herein, McConnel Ltd shall have no liability or responsibility to the purchaser or any other person or entity with respect to any liability, loss, or damage caused or alleged to be caused directly or indirectly by the goods including, but not limited to, any indirect, special, consequential, or incidental damages resulting from the use or operation of the goods or any breach of this warranty. Notwithstanding the above limitations and warranties, the manufacturer's liability hereunder for damages incurred by the purchaser or others shall not exceed the price of the goods.*
- 3.04. *No action arising out of any claimed breach of this warranty or transactions under this warranty may be brought more than one (1) year after the cause of the action has occurred.*

4. MISCELLANEOUS

- 4.01. *McConnel Ltd may waive compliance with any of the terms of this limited warranty, but no waiver of any terms shall be deemed to be a waiver of any other term.*
- 4.02. *If any provision of this limited warranty shall violate any applicable law and is held to be unenforceable, then the invalidity of such provision shall not invalidate any other provisions herein.*
- 4.03. *Applicable law may provide rights and benefits to the purchaser in addition to those provided herein.*



DECLARATION OF CONFORMITY

Conforming to EU Machinery Directive 2006/42/EC

We,

McCONNEL LIMITED, Temeside Works, Ludlow, Shropshire SY8 1JL, UK

Hereby declare that:

The Product; *Tractor Trailed Horizontal Folding Rollers*

Product Code; *TWBR , TWFR , THFR*

Serial No. & Date Type

Manufactured in; *United Kingdom*

Complies with the required provisions of the Machinery Directive 2006/42/EC
The machinery directive is supported by the following harmonized standards;

- BS EN ISO 12100 (2010) Safety of machinery – General principles for design – Risk assessment and risk reduction.
- BS EN 349 (1993) + A1 (2008) Safety of machinery - Minimum distances to avoid the entrapment with human body parts.
- BS EN 953 (1997) + A1 (2009) Safety of machinery - Guards general requirements for the design and construction of fixed and movable guards.
- BS EN 4413 (2010) Hydraulic fluid power. Safety requirements for systems and their components.

McCONNEL LIMITED operates an ISO 9001:2008 quality management system, certificate number: FM25970.

This system is continually assessed by the;
British Standards Institution (BSI), Beech House, Milton Keynes, MK14 6ES, UK
BSI is accredited by UK Accreditation Service, accreditation number: UKAS 003.
The EC declaration only applies if the machine stated above is used in accordance with the operating instructions.

Signed *Responsible Person*
CHRISTIAN DAVIES on behalf of McCONNEL LIMITED

Status: *General Manager*

Date: *May 2016*

**THIS MANUAL IS TO BE HANDED TO THE CUSTOMER BEFORE THE
MACHINE IS TO BE USED FOR THE FIRST TIME**



McCONNEL LIMITED
TEMESIDE WORKS
LUDLOW
SHROPSHIRE
SY8 1JL

TEL: (01584) 873131
Email: sales@mcconnel.com

All dimensions and capacities mentioned in this book are approximate. In pursuance of the Companies policy of constant development, the right is reserved to depart, without notice, from any detail illustrated or specified in this book, without incurring the obligation to provide such modifications on machines previously delivered.

No responsibility will be accepted by McConnel Limited for any injury, damage or loss arising from the improper use or lack of maintenance of any machinery supplied by them or from any failure of the user to comply with all instructions published by Tractor or Loader manufacturers, particularly with regard to maximum load capacities, tyre pressures and stability, or with instructions and regulations pertaining to Tractor Cabs.

INDEX

GENERAL INFORMATION	1
INTRODUCTION	2
GENERAL ARRANGEMENT	3
SPECIFICATIONS	5
HEALTH AND SAFETY	6
GENERAL INSTRUCTIONS	9
OPERATING INSTRUCTIONS	10
SAFETY WHEN ROLLING	12
ROUTINE MAINTENANCE AND LAYING-UP	13

GENERAL INFORMATION

NOTE: This handbook has been designed to help the operator and service/mechanic to use and understand the machine fully, safely and efficiently.

NOTE: It is very important that the handbook/manual has been read thoroughly - throughout, and is completely understood before attempting to attach or use the machine in any way.
The operator should also read and fully understand the manuals supplied by the tractor manufacturer and also any relevant information available from the Health and Safety Executive.

CAUTION: When ordering spares, please state clearly:

- (a) *Machine type and model No.*
- (b) *Part No. of component.*
- (c) *Description of component.*
- (d) *Quantity required.*
- (e) *Full address to which spares are to be sent.*
- (f) *Method of delivery required.*

CAUTION: Always insist on genuine and correct spare parts.

NOTE: Further copies of this handbook/manual can be obtained from:

McCONNEL LIMITED
TEMESIDE WORKS
LUDLOW
SHROPSHIRE
SY8 1ND

TELEPHONE:
01584 873131

INTRODUCTION

This manual describes a range of 3 gang folding Cambridge type rollers available in 6.4m, 7.3m or 8.2m working widths. A choice of Cambridge or Cambridge/breaker ring element combinations is available in 19" (480mm), 22" (560mm) or 24" (610mm) diameter. A set of wheels with pneumatic tyres permits transportation of the machine.

The machines have fabricated steel frames and the roller shafts rotate in sealed roller bearings

The wings are folded and the axle and wheels are raised and lowered from the transport to work positions hydraulically by double acting rams. Hydraulic power is provided from the tractors double acting spool valve.

The hydraulic hoses are provided with quick release couplings complete with dust covers.

Optional levelling boards and stone troughs are available. The levelling boards may be set in the work position or the 'out of work' position hydraulically. A lighting kit is also available for use when transporting the machine on the public highway.

It is designed for attachment to an agricultural vehicle by means of the 'Draw-bar-hitch' couple-up system.

The purpose for its production and its sole intention is to roll suitable pieces of land. Never attempt to use this machine for anything other than the task for which it was designed.



GENERAL ARRANGEMENT

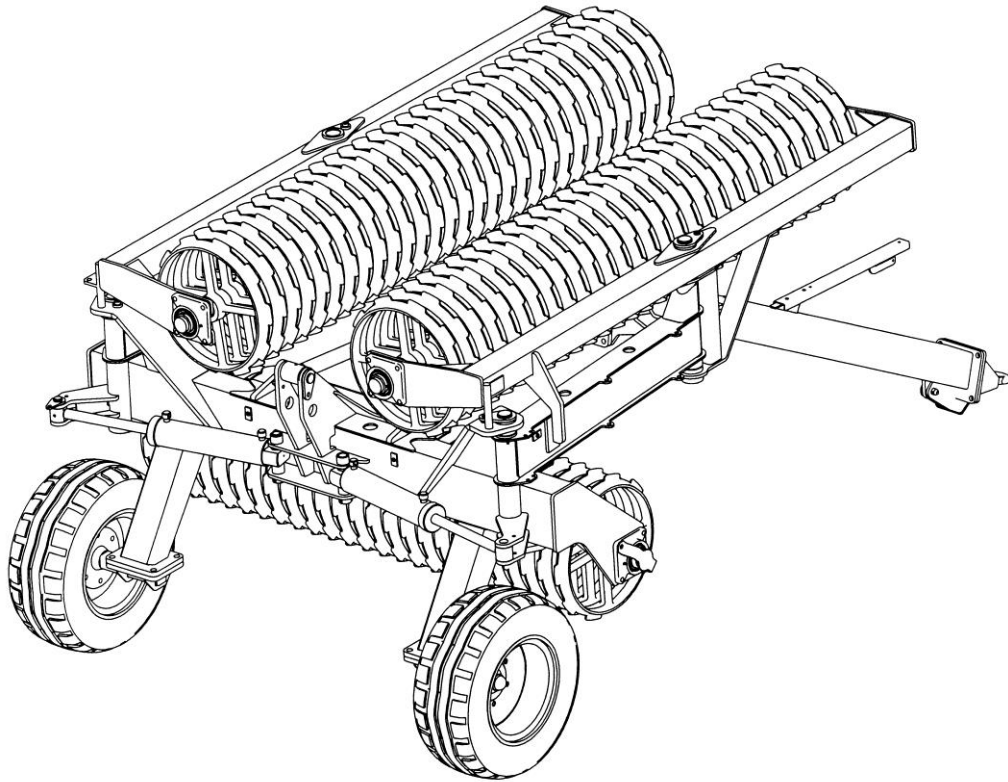

7.3M ROLLER IN FOLDED TRANSPORT POSITION

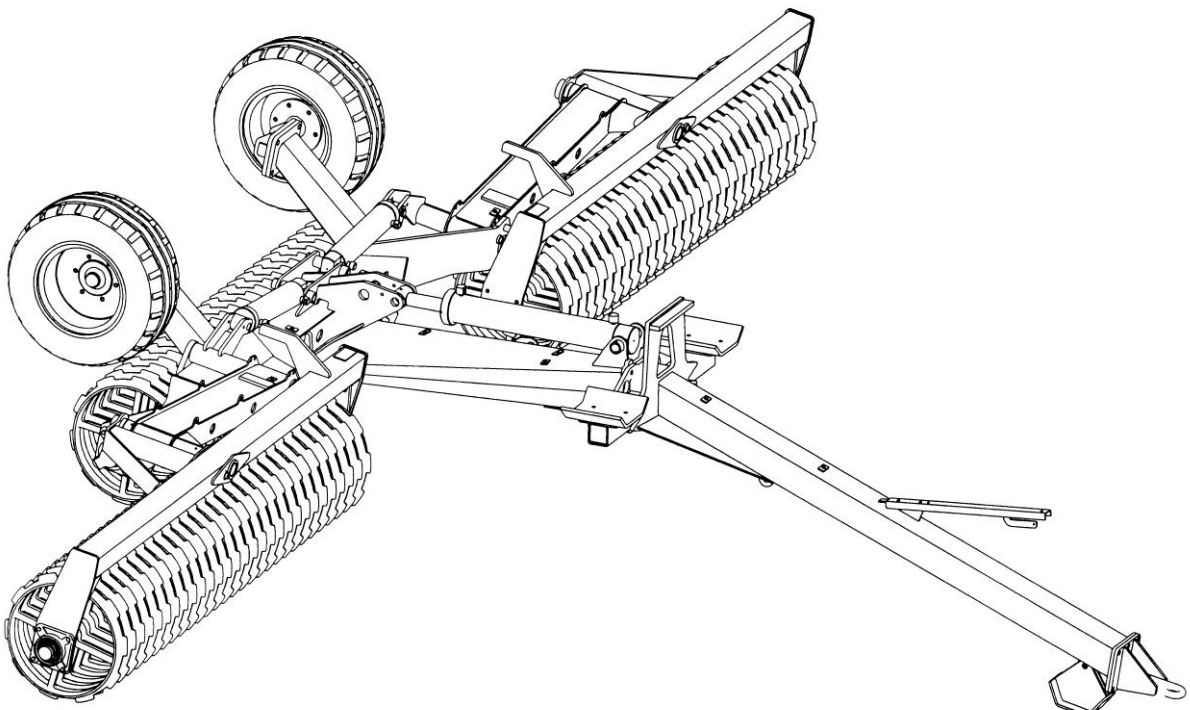

7.3M ROLLER IN WORKING POSITION

GENERAL ARRANGEMENT

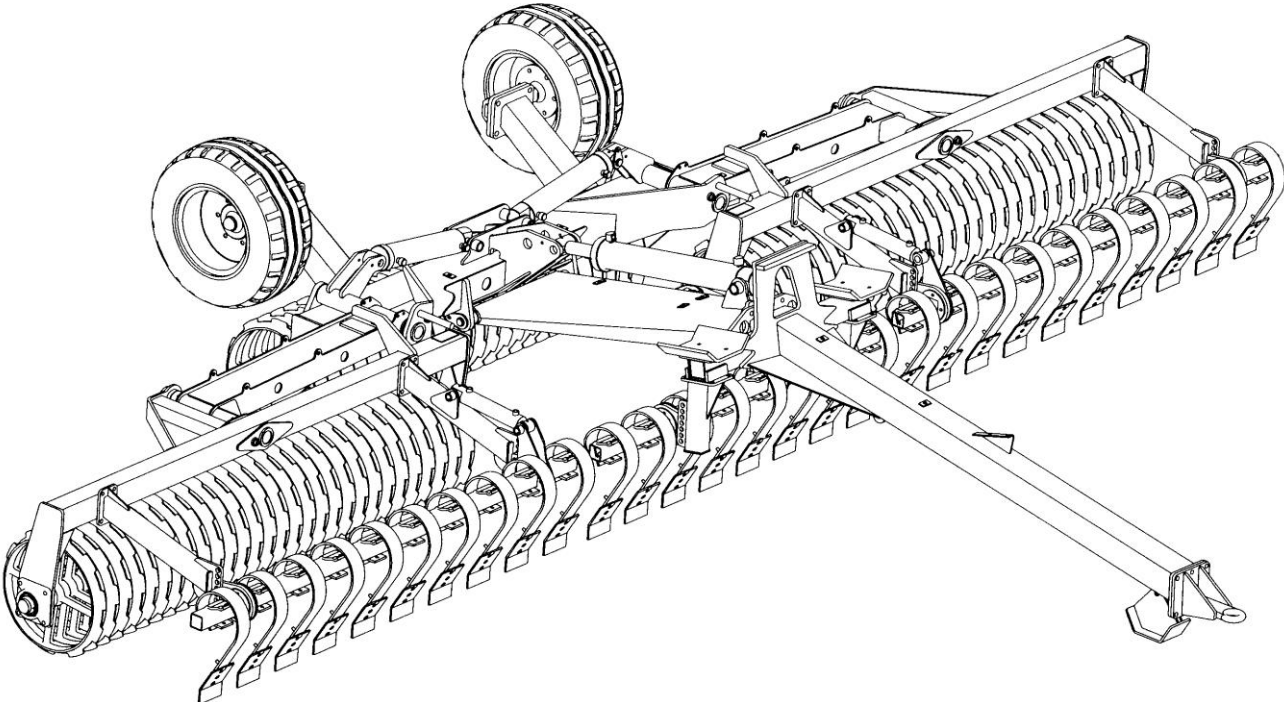

7.3M ROLLER WITH LEVELLING BOARDS ATTACHED

SPECIFICATIONS

ROLLERS

	6.4M	7.3M	8.2M
Height in work	1.4m	1.4m	1.4m
Height folded	1.9m	1.9m	1.9m
Height folded with levelling boards	2.7m	2.7m	2.7m
Length in work	5.3m	5.6m	5.9m
Length folded	4.1m	4.8m	5.5m
Width in work (Rolling width)	6.4m	7.3m	8.2m
Total working width	6.8m	7.7m	8.6m
Width folded	2.7m	2.7m	2.7m

Weight:-19" Rings

CB3 Rings	4150kg	4580kg	4900kg
-----------	--------	--------	--------

Weight:-22" Rings

C2 Rings	4350kg	4650kg	4950kg
CB4 Rings	5000kg	5400kg	5800kg

Weight:-24" Rings

LC2 Rings	4650kg	5050kg	5450kg
-----------	--------	--------	--------

Note: All weights are for machines complete with levelling boards

Tyre Size / Tyre Pressure (All models) 12.5/80 x 15.3 – 14 ply / 70 PSI (5.2 Bar)

TRACTOR REQUIREMENTS

	6.4M	7.3M	8.2M
Power	100hp (min) Recommended	100hp (min) Recommended	100hp (min) Recommended
Hydraulic Supply			
Rollers without Levelling boards	1 Double Acting Spool Valve with float function 1 Single Acting Spool Valve with float function		
Rollers with Levelling boards	2 Double Acting Spool Valves – one with float function 1 Single Acting Spool Valve with float function		

OPTIONS

Weight Trough Light Kit	Weight Trough Light Kit	Weight Trough Light Kit
----------------------------	----------------------------	----------------------------

IMPORTANT

To permit even rolling and to allow the roller sections to follow ground contours the wing and main centre rams should be placed in the float mode. This allows hydraulic oil to enter and exit the hydraulic rams on the roller and the tractor un-pressurised.

The levelling boards (when fitted) should be fully lowered into the work position or folded up when not required. The tine angle cannot be adjusted using the hydraulic rams.

HEALTH AND SAFETY

Throughout the handbook the following sub headings are used to draw attention to various points of importance.



**DANGER
WARNING**

This is to draw attention to very important instructions that MUST be followed precisely to avoid injury or death.

CAUTION This is used to draw attention to instructions that **MUST** be followed to avoid damage to operator, machine, process or the environment.

NOTE This is used to highlight points used for supplementary information.

HEALTH AND SAFETY



**DANGER
WARNING**

Never attempt to assemble, couple up, or operate machinery until you understand fully the functions, controls and safety precautions required, as shown in the operators manual.



**DANGER
WARNING**

Always follow tractor safety operations and instructions VERY carefully.

NEVER TAKE RISKS

CAUTION

Be aware of warning and instruction decals on machine as care must be taken and instructions obeyed.



**DANGER
WARNING**

Transport the machinery only at safe speeds. Never drive machinery at speeds that could cause danger to other persons or properties, or in a manner that may cause accidents.



**DANGER
WARNING**

Never attempt to Service/adjust or work on any machinery in an unsupported state.

Always ensure that machinery is safely supported and propped in position to prevent sudden or inadvertent falling that could cause serious injury or even death.



**DANGER
WARNING**

Ensure helpers and bystanders are well clear of the machine when unfolding or folding the rolls. There is a danger of crushing, trapping, impact or other serious injury

CAUTION

Always 'SWITCH OFF' the tractor's engine before attempting to carry out inspection, adjustments or service repairs on the machine.

HEALTH AND SAFETY



DANGER WARNING

Always be aware of your surroundings - and operate machinery accordingly. Beware of confined or tight areas, low height restrictions, buildings and overhangs etc. Also drive and operate bearing in mind weather conditions such as sun, rain, ice, snow, wind etc. Make allowances in all situations.

CAUTION

Never carry passengers on the machinery or on the tractor. Falling off can result in serious injury or even death. Ensure bystanders/onlookers are kept well away from the operational area of apparatus.

CAUTION

When machine is being removed from tractor's linkage and being 'parked up' it is essential that a good firm base and level site is used.

Always chock and prop machine to prevent moving. Ensure that stand legs of machine (if fitted) are correctly locked into position.

CAUTION

Never allow children to play on, or around, parked machinery.

CAUTION

Never wear loose fitting or ragged clothing that could get caught in machinery or controls.

CAUTION

Always dispose of discarded or worn out parts thoughtfully - by disposing of them in an approved and specified legal scrap site, bin or skip.



DANGER WARNING

Do not mount or exit the Tractor while the tractor is moving. Mount or leave the Tractor only when the Tractor and all moving parts have completely stopped.



DANGER WARNING

Do not operate this Equipment with hydraulic oil leaking. The presence could present a hazard. Do not check for leaks with your hand! Use a piece of heavy paper or cardboard. High-pressure oil streams from breaks in the line could penetrate the skin and cause tissue damage including gangrene. If oil does penetrate the skin get medical attention immediately.

GENERAL INSTRUCTIONS



DANGER WARNING

1. Before attaching any machine to a tractor make sure that implement is still standing firmly on good solid - level site as it will be, providing unit was previously parked correctly.
Check that any wheels are 'chocked' correctly and that supports/props are in position where necessary to prevent booms etc. dropping.
2. Before and during the manoeuvring of the tractor or vehicle in order to attach machinery/implements, - make sure that No other persons are in the vicinity.
Keep other persons well clear and make known your intentions, all the while keeping a sharp lookout whilst reversing and aligning machines for coupling up.
3. Always secure tractor into selected position by ensuring that brakes are applied correctly in order to prevent vehicle moving off on its own to cause injury and damage.
4. Check that the hitch on the tractor is in good condition and that the hitch pin used is of the correct size and type to suit the draw bar of the roller, and is properly secured when fitted.
5. Never attempt to work on, adjust or service repair machinery of any kind whilst it is still running or working. Always stop the machine and **STOP THE TRACTOR ENGINE** before any service/repairs begin.
SWITCH OFF THE TRACTOR ENGINE BEFORE LEAVING THE TRACTOR SEAT
6. In transit always use transport stays or locking devices where provided.
If, as in the case of some longer machines, the unit is transported lengthways - make sure that the front of the tractor is suitably ballasted to maintain stability.
A method of achieving this would be to add suitable weights to a correctly specified and fitted front weight frame.
7. Always use machines in a sensible and reasonable manner and do not attempt to use them in work for which they are not intended. Avoid overloading and abusing them as this can cause damage to machine and tractor and can be very dangerous.
8. When detaching a machine from a tractor ensure that any stands or legs are securely positioned and that the machine is parked where it will not be a safety hazard or cause annoyance to others.
Make sure that chosen 'parking site' is firm and level.
9. Carry out regular periodic maintenance. - Always with safety in mind.

OPERATING INSTRUCTIONS

Attaching Roller to the Tractor

1. Position tractor and align tractor's hitch with draw bar of roller.
2. Attach roller draw bar to the hitch, fit draw bar pin and lock in position.
3. Couple the hydraulic 'quick release' fittings to the tractor,

Note: One single acting service with float function is required for the main lift/draw bar ram.

One double acting spool with float is required for the wing rams.

If levelling boards are fitted a third double acting spool valve is required; this does not require the float function.

4. Remove the draw bar skid and place in the storage position on the draw bar.

CAUTION: To fold or unfold the roller a flat and even site should be used.

To Change the Roller from Transport to In Work Position

1. Extend the main ram to the fully open position.
2. Retract the wing rams so that the wing sections pivot open fully.
3. Retract the main ram so that the transport wheels lift clear of the ground and the machine is supported on the centre roller. Leave the spool valve in the float position.

Note: Depending on surface conditions it may be necessary to move the tractor forward very slowly to assist this operation.

4. Extend the wing rams to lower the wing sections to the ground. Place the spool valve in the float position.

If levelling boards are fitted they can be set in the fully raised or lowered position. The rams **must not** be allowed to float and the tine angle cannot be adjusted hydraulically.

To Change the Roller from In Work to Transport Position

1. Place all spool valves in the neutral position and out of float.
Note:- If levelling boards are fitted they should be fully folded 'out of work'.
2. Operate the wing rams to fully charge the cylinders.
3. Operate the main ram and fully extend it; this will lift the centre roller off the ground and the machine will rest on its transport wheels.
4. Extend the wing rams and slowly fold in the wings.
5. Operate the main ram to lower the wing sections into their carriers.
6. Place all spool valves in the NEUTRAL position.

Parking the Machine

1. Find a good firm level site preferably under cover for long term storage
2. Park roller in the desired position and apply tractor handbrake.
3. Chock the roller wheels to prevent movement.
4. Remove the draw bar skid from stored position into the front hole of draw bar, fit the pin and secure with linch pin.
5. Ensure hoses are not pressurised and remove hydraulic connections from tractor – fit dust caps to tractor and hoses, and disconnect road lighting plug (if fitted).
6. Slot hoses into the hose stand on the draw bar.
7. Lower tractors hitch and. remove towing pin from draw bar
8. Carefully drive tractor forward.

Note: Rollers can be stored in the work or the transport position.

Adjusting Draw-bar Height

The draw hitch height can be adjusted to suit the tractor used by repositioning the hitch eye - see illustrations below.

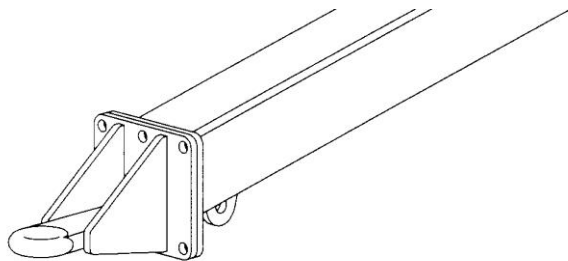

Position 1

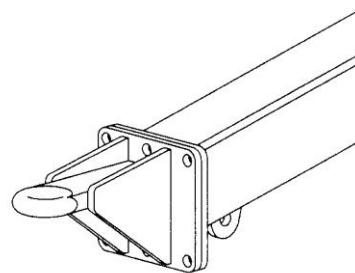

Position 2

Adjusting the Levelling Board Height ►

Four depth settings are available. These can be changed by removing the two bolts in each levelling board pivot and raising or lowering the position of the pivots and beams as necessary.

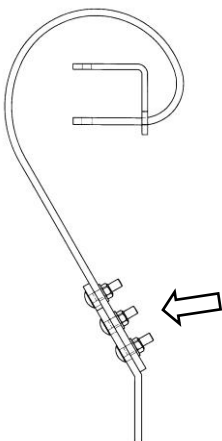
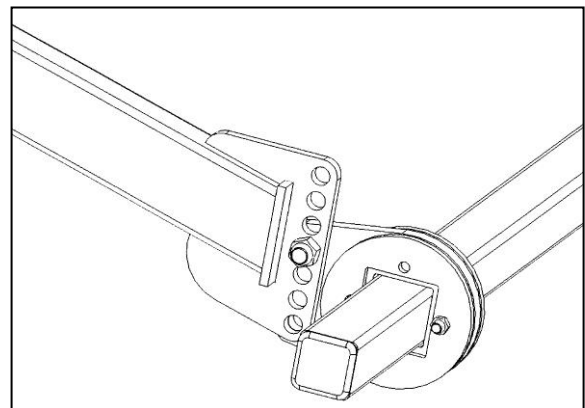

◀ Levelling Board Tine Wear

As the tine feet wear it will be necessary to adjust the position between the body and foot - there are two positions available.

SAFETY WHEN ROLLING



**DANGER
WARNING**

Before starting work with any roller ensure that the bearings are properly greased and that all bolts and nuts are tight.



**DANGER
WARNING**

Remember that a heavy roller will add to your momentum and will require a longer distance for stopping. Particular care will be needed on hilly or sidling ground.



**DANGER
WARNING**

Avoid turning so acutely that the tractor's rear wheels foul the rollers draw bar.



**DANGER
WARNING**

Do not attempt to use rollers when the ground conditions are unsuitable i.e.
When ground is excessively wet or greasy.
When ground is frozen or thawing after a frost.



**DANGER
WARNING**

Do not attempt to use the rollers on very steep sloping ground.

ROUTINE MAINTENANCE AND LAYING-UP

Daily

- Grease wheel bearings.
- Grease shaft bearings thoroughly.
- Check wheel nuts for tightness – 185 lbs.ft. (*250 Nm*).

Weekly

- Grease pivot points thoroughly.
- Check all bolts and nuts for tightness. The bolts securing the front and rear sections of the draw bar should be torque tightened to 255lbsft (*350 Nm*).
- Check all hoses for splits or damage.
- Check all rams for leaks or damage.
- Check tyres for damage and ensure they are inflated to the correct pressure – 70 psi (*5.2Bar*).

Annually & Laying Up

- Periodically (once a year should suffice) check the bearings, wheel bearings, pivot pins, bushes, spacers and axles for wear; dismantling if necessary. Replace any parts that are appreciably worn.
- Apply grease to all exposed ram rods and plated parts.
- Lubricate and use anti-corrosion measures when storing the roller.



McConnel Limited, Temeside Works, Ludlow, Shropshire SY8 1JL. England.
Telephone: 01584 873131. Facsimile: 01584 876463. www.mcconnel.com