

**TWOSE**  
**LEVELLING**  
**ATTACHMENTS**  
**GT-250FL & GT-300FL**  
Operation & Parts Manual

Publication 759 (Dec. 2013)

Part No. 22675.59



# IMPORTANT VERIFICATION OF WARRANTY REGISTRATION



## DEALER WARRANTY INFORMATION & REGISTRATION VERIFICATION

It is imperative that the selling dealer registers this machine with Twose of Tiverton Limited before delivery to the end user – failure to do so may affect the validity of the machine warranty.

To register machines go to the Twose web site at [www.twose.com](http://www.twose.com), log onto 'Dealer Inside' and select the 'Machine Registration button' which can be found in the Service Section of the site. Confirm to the customer that the machine has been registered in the section below.

Should you experience any problems registering a machine in this manner please contact the Twose Office on 01884 253691.

### Registration Verification

Dealer Name: .....
Dealer Address: .....
Customer Name: .....
Date of Warranty Registration: ...../...../..... Dealer Signature: .....

### NOTE TO CUSTOMER / OWNER

*Please ensure that the above section above has been completed and signed by the selling dealer to verify that your machine has been registered with Twose of Tiverton Limited.*

**IMPORTANT:** During the initial 'bedding in' period of a new machine it is the customer's responsibility to regularly inspect all nuts, bolts and hose connections for tightness and re-tighten if required. New hydraulic connections occasionally weep small amounts of oil as the seals and joints settle in – where this occurs it can be cured by re-tightening the connection – *refer to torque settings chart below*. The tasks stated above should be performed on an hourly basis during the first day of work and at least daily thereafter as part of the machines general maintenance procedure.

### TORQUE SETTINGS FOR HYDRAULIC FITTINGS

HYDRAULIC HOSE ENDS		
BSP	Setting	Metric
1/4"	18 Nm	19 mm
3/8"	31 Nm	22 mm
1/2"	49 Nm	27 mm
5/8"	60 Nm	30 mm
3/4"	80 Nm	32 mm
1"	125 Nm	41 mm
1.1/4"	190 Nm	50 mm
1.1/2"	250 Nm	55 mm
2"	420 Nm	70 mm

PORT ADAPTORS WITH BONDED SEALS		
BSP	Setting	Metric
1/4"	34 Nm	19 mm
3/8"	47 Nm	22 mm
1/2"	102 Nm	27 mm
5/8"	122 Nm	30 mm
3/4"	149 Nm	32 mm
1"	203 Nm	41 mm
1.1/4"	305 Nm	50 mm
1.1/2"	305 Nm	55 mm
2"	400 Nm	70 mm

# WARRANTY POLICY

## WARRANTY REGISTRATION

All machines must be registered, by the selling dealer with Twose of Tiverton Ltd, before delivery to the end user. On receipt of the goods it is the buyer's responsibility to check that the Verification of Warranty Registration in the Operator's Manual has been completed by the selling dealer.

### 1. LIMITED WARRANTIES

- 1.01. *All machines supplied by Twose of Tiverton Ltd are warranted to be free from defects in material and workmanship from the date of sale to the original purchaser for a period of 12 months, unless a different period is specified.*
- 1.02. *All spare parts supplied by Twose of Tiverton Ltd and purchased by the end user are warranted to be free from defects in material and workmanship from the date of sale to the original purchaser for a period of 6 months. All parts warranty claims must be supported by a copy of the failed part invoice to the end user. We cannot consider claims for which sales invoices are not available.*
- 1.03. *The warranty offered by Twose of Tiverton Ltd is limited to the making good by repair or replacement for the purchaser any part or parts found, upon examination at its factory, to be defective under normal use and service due to defects in material or workmanship. Returned parts must be complete and unexamined. Pack the component(s) carefully so that any transit damage is avoided. All ports on hydraulic items should be drained of oil and securely plugged to prevent seepage and foreign body ingress. Certain other components, electrical items for example, may require particular care when packing to avoid damage in transit.*
- 1.04. *This warranty does not extend to any product from which Twose of Tiverton Ltd's serial number plate has been removed or altered.*
- 1.05. *This warranty does not apply to any part of the goods, which has been subjected to improper or abnormal use, negligence, alteration, modification, fitment of non-genuine parts, accident damage, or damage resulting from contact with overhead power lines, damage caused by foreign objects (e.g. stones, iron, material other than vegetation), failure due to lack of maintenance, use of incorrect oil or lubricants, contamination of the oil, or which has served its normal life. This warranty does not apply to any expendable items such as blades, belts, clutch linings, filter elements, flails, flap kits, skids, soil engaging parts, shields, guards, wear pads, pneumatic tyres or tracks.*
- 1.06. *Temporary repairs and consequential loss - i.e. oil, downtime and associated parts are specifically excluded from the warranty.*
- 1.07. *Warranty on hoses is limited to 12 months and does not include hoses which have suffered external damage. Only complete hoses may be returned under warranty, any which have been cut or repaired will be rejected.*
- 1.08. *Machines must be repaired immediately a problem arises. Continued use of the machine after a problem has occurred can result in further component failures, for which Twose of Tiverton Ltd cannot be held liable, and may have safety implications.*
- 1.09. *If in exceptional circumstances a non Twose of Tiverton Ltd part is used to effect a repair, warranty reimbursement will be at no more than Twose of Tiverton Ltd's standard dealer cost for the genuine part.*
- 1.10. *Except as provided herein, no employee, agent, dealer or other person is authorised to give any warranties of any nature on behalf of Twose of Tiverton Ltd.*
- 1.11. *For machine warranty periods in excess of 12 months the following additional exclusions shall apply:*
  - 1.11.1. *Hoses, exposed pipes and hydraulic tank breathers.*
  - 1.11.2. *Filters.*
  - 1.11.3. *Rubber mountings.*
  - 1.11.4. *External electric wiring.*
  - 1.11.5. *Bearings and seals.*

- 1.12. All service work, particularly filter changes, must be carried out in accordance with the manufacturer's service schedule. Failure to comply will invalidate the warranty. In the event of a claim, proof of the service work being carried out may be required.
- 1.13. Repeat or additional repairs resulting from incorrect diagnosis or poor quality previous repair work are excluded from warranty.

**NB Warranty cover will be invalid if any non-genuine parts have been fitted or used. Use of non-genuine parts may seriously affect the machine's performance and safety. Twose of Tiverton Ltd cannot be held responsible for any failures or safety implications that arise due to the use of non-genuine parts.**

## **2. REMEDIES AND PROCEDURES**

- 2.01. The warranty is not effective unless the Selling Dealer registers the machine, via the Twose of Tiverton Ltd web site and confirms the registration to the purchaser by completing the confirmation form in the operator's manual.
- 2.02. Any fault must be reported to an authorised Twose of Tiverton Ltd dealer as soon as it occurs. Continued use of a machine, after a fault has occurred, can result in further component failure for which Twose of Tiverton Ltd cannot be held liable.
- 2.03. Repairs should be undertaken within two days of the failure. Claims submitted for repairs undertaken more than 2 weeks after a failure has occurred, or 2 days after the parts were supplied will be rejected, unless the delay has been authorised by Twose of Tiverton Ltd. Please note that failure by the customer to release the machine for repair will not be accepted as a reason for delay in repair or submitting warranty claims.
- 2.04. All claims must be submitted, by an authorised Twose of Tiverton Ltd Service Dealer, within 30 days of the date of repair.
- 2.05. Following examination of the claim and parts, Twose of Tiverton Ltd will pay, at their discretion, for any valid claim the invoiced cost of any parts supplied by Twose of Tiverton Ltd and appropriate labour and mileage allowances if applicable.
- 2.06. The submission of a claim is not a guarantee of payment.
- 2.07. Any decision reached by Twose of Tiverton Ltd is final.

## **3. LIMITATION OF LIABILITY**

- 3.01. Twose of Tiverton Ltd disclaims any express (except as set forth herein) and implied warranties with respect to the goods including, but not limited to, merchantability and fitness for a particular purpose.
- 3.02. Twose of Tiverton Ltd makes no warranty as to the design, capability, capacity or suitability for use of the goods.
- 3.03. Except as provided herein, Twose of Tiverton Ltd shall have no liability or responsibility to the purchaser or any other person or entity with respect to any liability, loss, or damage caused or alleged to be caused directly or indirectly by the goods including, but not limited to, any indirect, special, consequential, or incidental damages resulting from the use or operation of the goods or any breach of this warranty. Notwithstanding the above limitations and warranties, the manufacturer's liability hereunder for damages incurred by the purchaser or others shall not exceed the price of the goods.
- 3.04. No action arising out of any claimed breach of this warranty or transactions under this warranty may be brought more than one (1) year after the cause of the action has occurred.

## **4. MISCELLANEOUS**

- 4.01. Twose of Tiverton Ltd may waive compliance with any of the terms of this limited warranty, but no waiver of any terms shall be deemed to be a waiver of any other term.
- 4.02. If any provision of this limited warranty shall violate any applicable law and is held to be unenforceable, then the invalidity of such provision shall not invalidate any other provisions herein.
- 4.03. Applicable law may provide rights and benefits to the purchaser in addition to those provided herein.





**Twose of Tiverton Limited**

6 Chinon Court,  
Lower Moor Way,  
Tiverton Business Park,  
Tiverton,  
Devon. EX16 6SS.

Telephone: (01884) 253691

Fax: (01884) 255189

Email [sales@twose.com](mailto:sales@twose.com)

Web: [www.twose.com](http://www.twose.com)



# DECLARATION OF CONFORMITY

*Conforming to EU Machinery Directive 2006/42/EC*

We,

**TWOSE of TIVERTON LIMITED,**  
6 Chinon Court, Lower Moor Way,  
Tiverton Business Park, Tiverton, Devon, EX16 6SS, UK

*Hereby declare that:*

The Product; *Tractor Mounted Levelling Attachment*

Product Code; *TFRA*

Serial No. & Date ..... Type .....

Manufactured in; *Denmark*

Complies with the required provisions of the Machinery Directive 2006/42/EC  
The machinery directive is supported by the following harmonized standards;

- BS EN ISO 12100 (2010) Safety of machinery – General principles for design – Risk assessment and risk reduction.
- BS EN 349 (1993) + A1 (2008) Safety of machinery - Minimum distances to avoid the entrapment with human body parts.
- BS EN 953 (1997) + A1 (2009) Safety of machinery - Guards general requirements for the design and construction of fixed and movable guards.
- BS EN 4413 (2010) Hydraulic fluid power. Safety requirements for systems and their components.

Signed  ..... *Responsible Person*  
*CHRISTIAN DAVIES on behalf of TWOSE OF TIVERTON LIMITED*

Status: *General Manager*

Date: *September 2015*



# LIST OF CONTENTS

---

## **Operator Section**

General Information	1
Machine Description & Purpose of Use	2
Machine Identification	2
Technical Specifications	2
Safety Information	3
Vehicle / Tractor Preparation	5
General Instructions	6
Machine Attachment	7
Operation	7
Lubrication & Maintenance	7
Storage	7

## **Parts Section**

Mounting Brackets	9
Main Assembly	11
Blade Assemblies – <i>GT-250FL Model</i>	13
Blade Assemblies – <i>GT-300FL Model</i>	15

## GENERAL INFORMATION

---

Always read this manual before fitting or operating the machine – whenever any doubt exists contact your dealer or the Twose Service Department for advice and assistance.

### Use only Twose Genuine Service Parts on Twose Equipment and Machines

**DEFINITIONS** – The following definitions apply throughout this manual:

#### WARNING

An operating procedure, technique etc., which –  
can result in personal injury or loss of life if not observed carefully.

#### CAUTION

An operating procedure, technique etc., which –  
can result in damage to either machine or equipment if not observed carefully.

#### NOTE

An operating procedure, technique etc., which –  
is considered essential to emphasis.

#### LEFT AND RIGHT HAND

This term is applicable to the machine when attached to the tractor and is viewed  
from the rear – this also applies to tractor references.

## MACHINE & DEALER INFORMATION

---

*Record the Serial Number of your machine on this page and always quote this number when ordering parts. Whenever information concerning the machine is requested remember also to state the make and model of tractor to which the machine is fitted.*

Machine Serial Number:

Installation Date:

Machine Model details:

Dealer Name:

Dealer Address:

Dealer Telephone No:

Dealer Email Address:

## MACHINE DESCRIPTION & PURPOSE OF USE

The GT-250FL & GT-300FL are tractor mounted levelling attachments primarily designed for soil preparation tasks, general levelling duties and snow or ice clearance.

Models are equipped as standard with hydraulically adjustable blade units that offer up to 25° of turn on either side of the machine. Adjustable wheels are available for the provision of setting the blade working height.

*These machines should only be used to perform tasks for which they were designed – use of the machine for any other function may be both dangerous to persons and damaging to components and is therefore not advisable.*

## MACHINE IDENTIFICATION

Each machine is fitted with an identification plate with the following information:

1. Machine (Part Number)
2. Machine Serial No.
3. Machine Weight

When ordering spares or replacement parts from your local dealer it is important to quote both Part Number and Serial Number as stated on the identification plate so the machine and model can be quickly and correctly identified.



**Machine Identification Plate**

## TECHNICAL SPECIFICATIONS

SPECIFICATION	GT-250FL	GT-300FL
Working Width	2.5m (8' 2")	3.0m (9' 7")
Blade Height	0.6m (1' 9")	0.6m (1' 9")
Hydraulic Rams	2	2
Weight	390 kg (859 lbs)	425 kg (936 lbs)
Blade Options	Plain / Plain Plain / Serrated Serrated / Serrated	Plain / Plain Plain / Serrated Serrated / Serrated

## SAFETY INFORMATION

---

### General safety rules:

- ▲ Always read and follow the instructions for the use and maintenance of the machine before carrying out any work operations or servicing tasks.
- ▲ Improper use of the machine is both highly dangerous to persons and damaging to the machine components – only use the machine for its designated task.
- ▲ Both operators and the maintenance fitters should be familiar with the machine and fully aware of dangers surrounding improper use or incorrect repairs.
- ▲ Before starting, checks to both tractor and machine must be carried out as regards: functionality, road safety, accident prevention rules.
- ▲ When using the machine all bystanders and onlookers should be kept at a safe distance from the tractor and machine. Special attention must be paid when working in or near buildings.
- ▲ Use tractor's fitted with safety cabs.
- ▲ The condition of the machine must be checked before use – do not use the machine if components are missing or damaged.
- ▲ During checks or repairs, make sure nobody could start the machine by mistake.
- ▲ Never wear loose or fluttering clothes when operating machines.
- ▲ Never carry passengers on the tractor.
- ▲ Never carry passengers on the machine.
- ▲ Never connect the power takeoff with the engine running.
- ▲ Never leave the tractor seat whilst the engine or machine is running.
- ▲ Before starting, check the surrounding area for the likely presence of children and/or animals.
- ▲ Do not stand near the machine when it is raised or operating.
- ▲ Immediately replace missing or damaged safety decals.
- ▲ Before leaving the tractor with a machine attached, proceed as follows:
  1. Put the machine steadily on the ground using the tractor's hydraulic lift.
  2. Apply the hand brake and, if the ground is steeply sloping, wedge the tractor.
  3. Remove the starting key.

### Transportation Safety

- ▲ In transport, reduce speed, especially on bumpy roads, the weight of the machine may render driving difficult and damage the machine itself.
- ▲ Ensure the levers that operate the hydraulic lift are locked, to avoid the lowering of the machine during transport.
- ▲ When driving on public roads, respect all road rules in force.
- ▲ Be aware of the width of a machine during use and transportation especially when operating in close proximity to obstacles and other vehicles.

## **Operating Safety**

- ▲ Pay special attention when working with the machine not to touch fixed objects such as drains, walls, kerbs, guard rails, tracks etc.
- ▲ It cannot be stressed enough the dangers involved when working in the vicinity of overhead power cables. Keep all machines clear of power lines at all times. Remember electrocution can occur without actually coming into contact with a power line as electricity can 'flash over' when machinery gets close to it.
- ▲ Always lower the machine to rest on the ground when not in use.
- ▲ Always ensure the machine is safely supported before attempting to carry out repairs or maintenance. Never work on a machine that is raised or unsupported.

---

**Although the information given here covers a wide range of safety subjects, it is impossible to predict every eventuality that can occur under differing circumstances whilst operating this machine. No advice given here can replace 'good common sense' and 'total awareness' at all times, but will go a long way towards the safe use of your Twose machine.**

---

## VEHICLE / TRACTOR PREPARATION

---

We recommend vehicles are fitted with cabs using 'safety glass' windows and protective guarding when used with our machines.

Fit Operator Guard (part no. 7313324) using the hooks provided. Shape the mesh to cover all vulnerable areas.

Remember the driver must be looking through mesh and/or polycarbonate

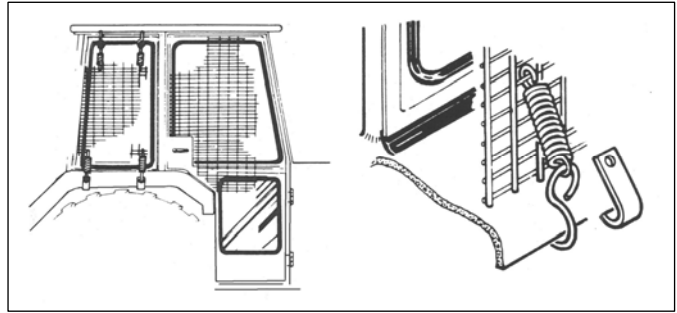

glazing when viewing the machine in all positions - unless the vehicle/ cab manufacturer can demonstrate that the penetration resistance is equivalent to, or higher than, that provided by mesh/polycarbonate glazing. If the tractor has a roll bar only, a frame must be made to carry both mesh and polycarbonate glazing. The operator should also use personal protective equipment to reduce the risk of serious injury such as; eye protection (mesh visor to EN1731 or safety glasses to EN166), hearing protection to EN352, safety helmet to EN297, gloves, filter mask and high visibility clothing.

### Vehicle Ballast

It is imperative when attaching 'third-party' equipment to a vehicle that the maximum possible stability of the machine and vehicle combination is achieved – this can be accomplished by the utilisation of 'ballast' in order to counter-balance the additional equipment added.

Front weights may be required for rear mounted machines to place 15% of total outfit weight on the front axle for stable transport on the road and to reduce 'crabbing' due to the drag of the cutting unit when working on the ground.

Where a machine works to the side of the tractor rear weights may be required to maintain a reasonable amount of rear axle load on the opposing wheel.

All factors must be addressed in order to match the type and nature of the equipment added to the circumstances under which it will be used - factors that effect stability are:

- *Centre of gravity of the tractor/machine combination.*
- *Geometric conditions, e.g. position of the cutting head and ballast.*
- *Weight, track width and wheelbase of the tractor.*
- *Acceleration, braking, turning and the relative position of the cutting unit during these operations.*
- *Ground conditions, e.g. slope, grip, load capability of the soil/surface.*
- *Rigidity of implement mounting.*

### Suggestions to increase stability:

- *Increasing rear wheel track - a vehicle with a wider wheel track is more stable.*
- *Ballasting the wheel; it is preferable to use external weights but liquid can be added to around 75% of the tyre volume – water with anti-freeze or the heavier Calcium Chloride alternative can be used.*
- *Addition of weights – care should be taken in selecting the location of the weights to ensure they are added to a position that offers the greatest advantage.*
- *Front axle locking, check with tractor manufacturer.*

---

The advice above is offered as a guide for stability only and is not a guide to vehicle strength. It is therefore recommended that you consult your vehicle manufacturer or local dealer to obtain specific advice on this subject, additionally advice should be sought from a tyre specialist with regard to tyre pressures and ratings suitable for the type and nature of the machine you intend to fit.

---

## GENERAL INSTRUCTIONS

---

1. Before attaching any machine to a tractor or loader make sure that implement is still standing firmly on a firm level site. Check that any wheels are chocked correctly and that supports/props are in position where necessary to prevent moveable components from dropping.
2. Before and during the maneuvering of the tractor or vehicle to attach machinery or implements, make sure that no other persons are in the vicinity. Keep other persons well clear and make known your intentions, all the while keeping a sharp lookout whilst reversing and aligning machines for coupling up.
3. Always ensure that brakes are applied correctly to secure the tractor into the selected position. This will prevent the vehicle from moving off on its own to cause injury and damage.
4. Make sure that any lift arms are properly fitted to the machine or implement using the correct adapter sleeves where necessary. Secure pins with relevant pin and ring assemblies.
5. Should it become necessary to make any adjustments or service the machine while raised on the tractor linkage or front end loader, trestles or suitable supports must be positioned to support machine to prevent accidental dropping of lift arms, loader arms or mechanical failure.

### MACHINES MUST ALWAYS BE PROPPED AND CHOCKED.

6. Never attempt to work on, adjust, service or repair machinery of any kind whilst it is still running or working. Always stop the machine and STOP THE TRACTOR ENGINE before making adjustments or repairs.

### SWITCH OFF THE TRACTOR ENGINE BEFORE LEAVING THE TRACTOR SEAT

7. In transit always use transport stays or locking devices where provided. If, as in the case of some larger machines make sure that the rear of the tractor or loader is suitably ballasted to maintain stability. A method of achieving this is to add suitable weights to a correctly specified and fitted rear weight frame.
8. Always use machines in a sensible and reasonable manner and do not attempt to use them for work for which they are not intended. Avoid overloading and abusing them as this can cause damage to machine and tractor and can be very dangerous.
9. When unhitching/detaching a machine from a front end loader ensure that any stands or legs are securely positioned. The machine must be parked where it will not be a safety hazard or cause annoyance to others. Make sure that chosen parking site is firm and level.
10. Carry out regular periodic maintenance, always with safety in mind.
11. Ensure regular maintenance procedures are maintained for the lifetime of the machine.

## ATTACHING THE MACHINE

---

The machines are supplied fully assembled and ready for mounting on the tractors front three-point hitch or front end loader. Ensure the machine is located on a firm level site for mounting and dismounting.

Always use the correct fixtures and fittings for securing the machine to the tractor and keep bystanders at a safe distance during the machine attachment procedure.

Attach hydraulic hoses to the tractors hydraulic service connection and check all functions are operating correctly before attempting to use the machine for work.

### **Operation**

Ensure all users of the machine are trained in using a machine of this nature and are familiar with all safety aspects relating to its use. Keep persons and animals clear of the machine at all times when working.

### **Lubrication & Maintenance**

Lubricate the machine with good quality grease once or twice a day during use. Grease nipples are located on pivot points, wheel brackets and wheels. Always lubricate the machine fully prior to use and prior to storage. Inspect the machine on a regular basis and replace excessively worn or damaged components immediately.

### **Machine Storage**

Storage of the machine should be in a clean dry environment protected from the elements. Clean and lubricate the machine prior to storage and ensure it is parked up in a safe condition.



LEVELLING ATTACHMENTS  
**GT-250FL & GT-300FL**

Parts Manual

MOUNTING BRACKETS

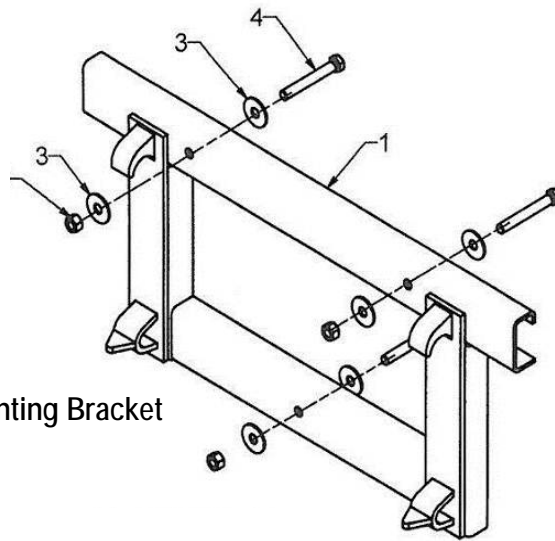

SMS Mounting Bracket

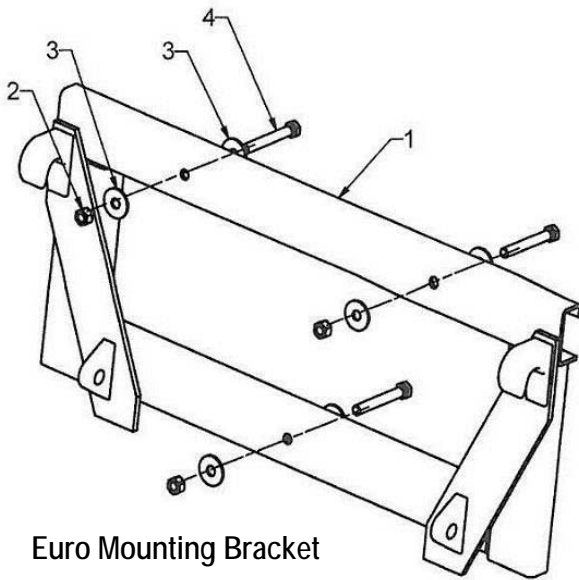

Euro Mounting Bracket

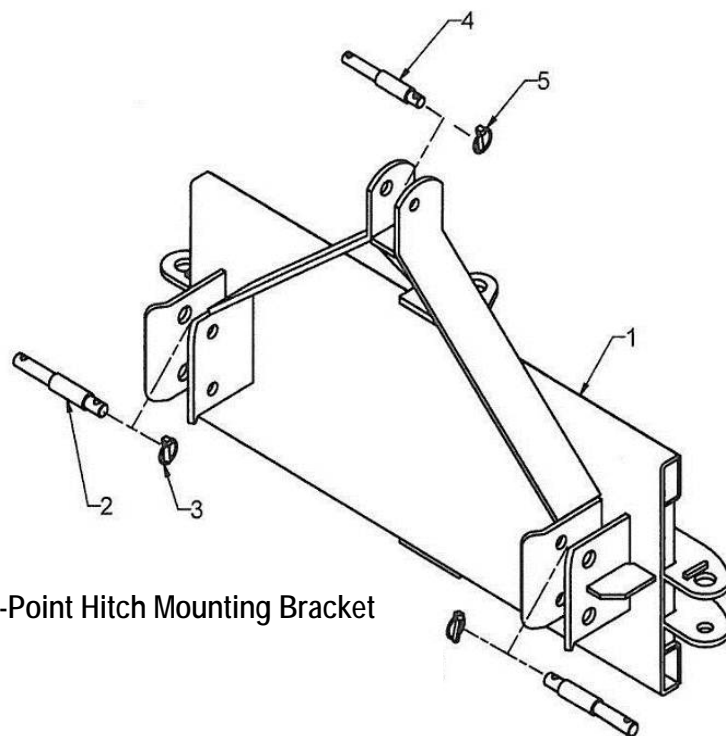

3-Point Hitch Mounting Bracket

## MOUNTING BRACKETS

REF.	QTY.	PART No.	DESCRIPTION
<b>SMS MOUNTING BRACKET</b>			
1	1	FD24520	MOUNTING BRACKET - SMS Type
2	3	FD740420016	LOCK NUT
3	6	FD740600042	WASHER
4	3	FD740211475	STEEL BOLT
<b>EURO MOUNTING BRACKET</b>			
1	1	FD24515	MOUNTING BRACKET - EURO Type
2	3	FD740420016	LOCK NUT
3	6	FD740600042	WASHER
4	3	FD740211475	STEEL BOLT
<b>3-POINT HITCH MOUNTING BRACKET</b>			
1	1	FD24525	MOUNTING BRACKET - 3-POINT Type
2	2	FD15536	3-POINT PIN
3	2	FD1210100	CUTTER
4	1	FD18006	3-POINT PIN
5	1	FD1210080	CUTTER

MAIN ASSEMBLY

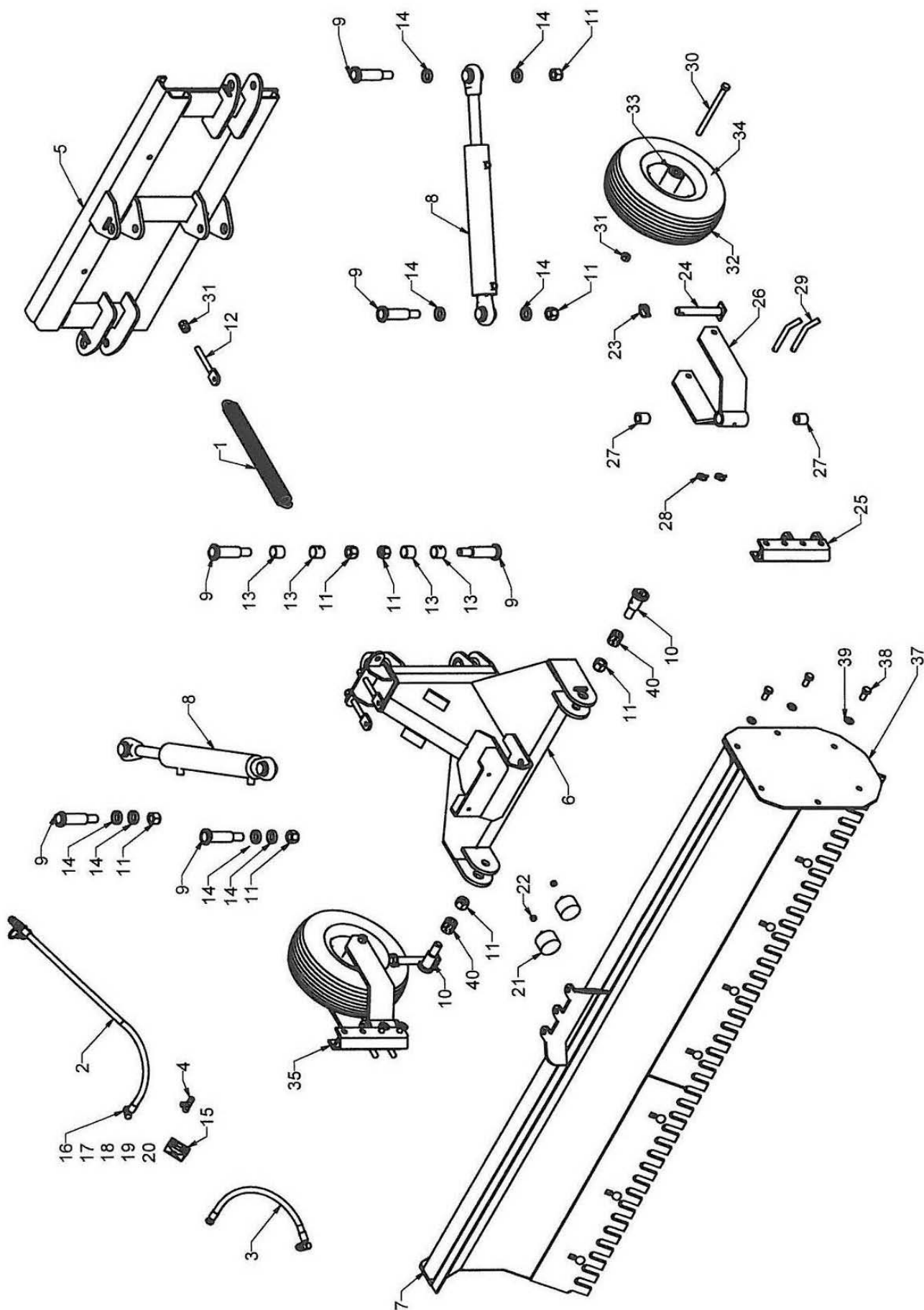

## MAIN ASSEMBLY

REF.	QTY.	PART No.	DESCRIPTION
<b>MAIN ASSEMBLY GT-250FL &amp; GT-300FL</b>			
1	3	FD24501	TENSION SPRING
2	2	FD24502	HYDRAULIC HOSE (COMPLETE)
3	4	FD24503	HYDRAULIC HOSE (COMPLETE)
4	1	FD24504	HYDRAULIC T PIECE
5	1	FD24505	FRONT FRAME
6	1	FD24506	CONNECTING FRAME
7	1	FD24507	LEVELLER - <i>GT-250FL Model</i>
	1	FD24530	LEVELLER - <i>GT-300FL Model</i>
8	2	FD24508	CYLINDER
9	6	FD24509	PIN
10	2	FD24510	PIN
11	8	FD740400045	LOCK NUT
12	3	FD24511	EYE BOLT
13	4	FD10535	BRONZE BEARING
14	8	FD24512	BRONZE BEARING
15	2	FD42603	HOLDER FOR HYDRAULIC HOSE
16	4	FD42419	HEXAGON NIPPLE
17	4	FD42418	WASHER
18	2	FD42414	QUICK COUPLER
19	2	FD42415	WASHER
20	2	FD42416	DUST CAP
21	2	FD46048	SHOCK ABSORBER
22	2	FD740420010	LOCK NUT
23	2	FD1210080	COTTER
24	2	FD25815	SHAFT
25	2	FD25816	BRACKET
26	2	FD25415	YOKE
27	4	FD25417	NYLON BEARING
28	4	FD1210045	COTTER
29	4	FD25418	STEEL PIN
30	2	FD740040595	STEEL BOLT
31	8	FD740390016	NUT
32	2	FD1383050	WHEEL (COMPLETE)
	2	FD1313004	TYRE
33	2	FD1333050	RIM
34	2	FD1323000	INNER TUBE
35	2	FD2514	WHEEL BRACKET (COMPLETE)
36	8	FD881500240	LUBRICATOR NIPPLE
37	1	FD2533	SIDE PLATE
38	3	FD740210545	BOLT
39	3	FD740760040	SPRING WASHER
40	2	FD10536	BRONZE BEARING

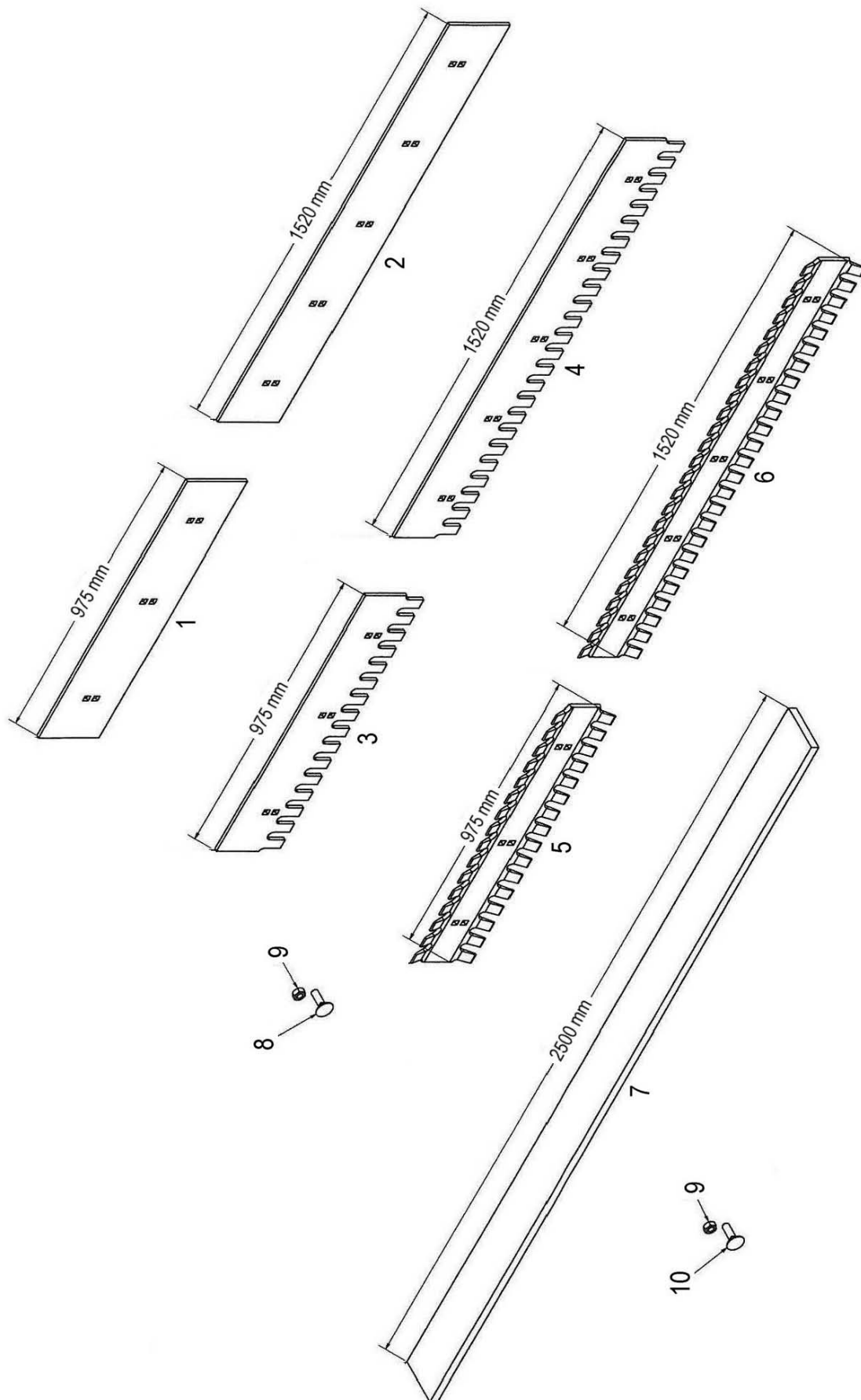

## BLADE ASSEMBLIES – GT-250FL Model

REF.	QTY.	PART No.	DESCRIPTION
			<b>BLADE ASSEMBLIES - GT-250FL Model</b>
1	1	FD26512	BLADE (975mm) - PLAIN / PLAIN
2	1	FD26513	BLADE (1520mm) - PLAIN / PLAIN
3	1	FD26516	BLADE (975mm) - PLAIN / SERRATED
4	1	FD26517	BLADE (1520mm) - PLAIN / SERRATED
5	1	FD26520	BLADE (975mm) - SERRATED / SERRATED
6	1	FD26521	BLADE (1520mm) - SERRATED / SERRATED
7	1	FD2518	RUBBER BLADE (2500mm)
8	8	FD26522	BOLT FOR BLADE
9	8	FD740420016	LOCK NUT
10	8	FD26523	BOLT FOR RUBBER BLADE



BLADE ASSEMBLIES – GT-300FL Model

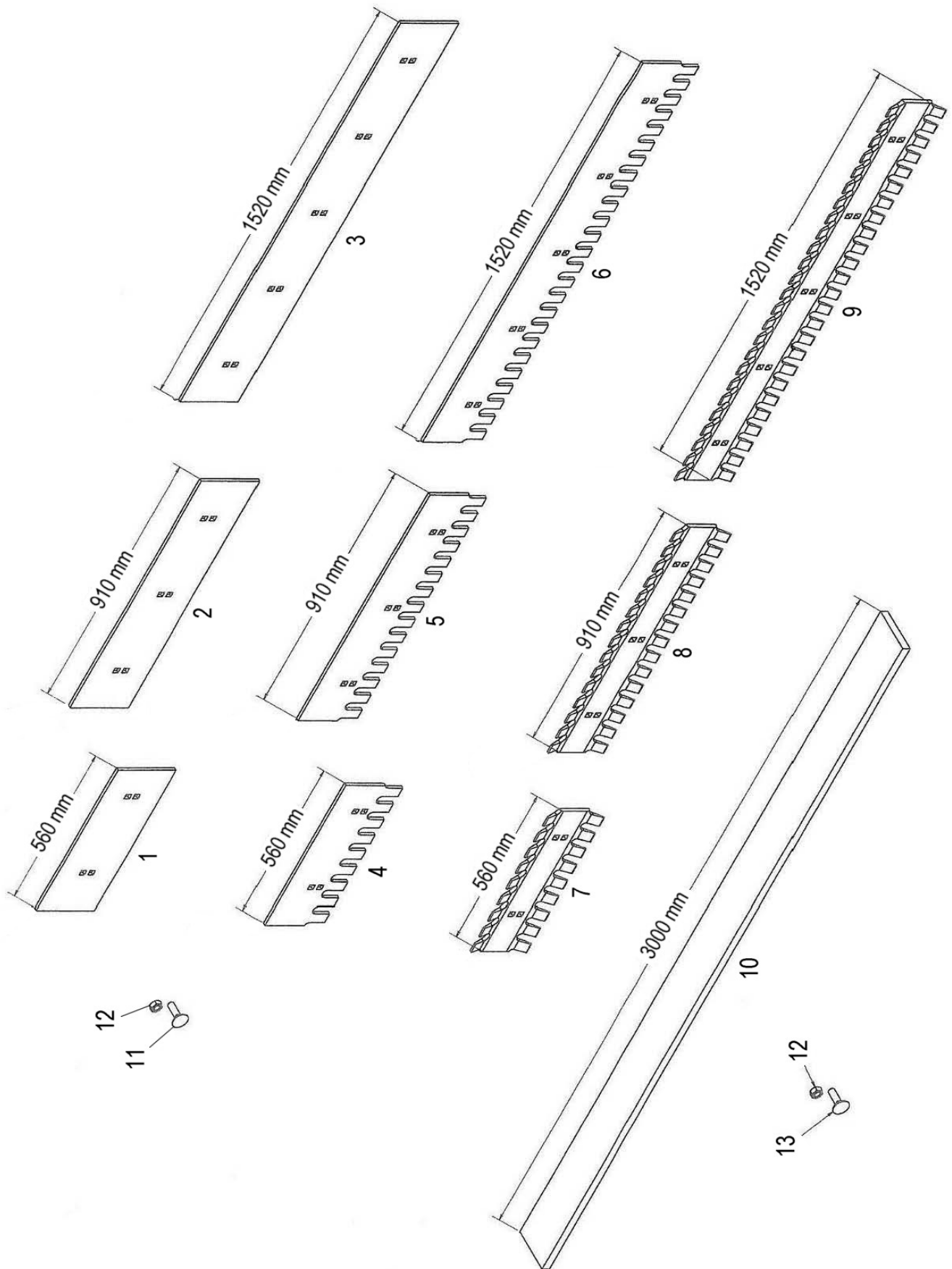



## BLADE ASSEMBLIES – GT-300FL Model

REF.	QTY.	PART No.	DESCRIPTION
			<b>BLADE ASSEMBLIES - GT-300FL Model</b>
1	1	FD26510	BLADE (560mm) - PLAIN / PLAIN
2	1	FD26511	BLADE (910mm) - PLAIN / PLAIN
3	1	FD26513	BLADE (1520mm) - PLAIN / PLAIN
4	1	FD26514	BLADE (560mm) - PLAIN / SERRATED
5	1	FD26515	BLADE (910mm) - PLAIN / SERRATED
6	1	FD26517	BLADE (1520mm) - PLAIN / SERRATED
7	1	FD26518	BLADE (560mm) - SERRATED / SERRATED
8	1	FD26519	BLADE (910mm) - SERRATED / SERRATED
9	1	FD26521	BLADE (1520mm) - SERRATED / SERRATED
10	1	FD2519	RUBBER BLADE (3000mm)
11	10	FD26522	BOLT FOR BLADE
12	10	FD740420016	LOCK NUT
13	10	FD26523	BOLT FOR RUBBER BLADE

