

FLAIL TRIMMERS -

460 520 580

Edition No: 7736-09-99





THIS MANUAL IS TO BE HANDED TO THE CUSTOMER BEFORE THE MACHINE IS TO BE USED FOR THE FIRST TIME.

THIS MANUAL (OR A COPY OF) MUST BE USED AND READ BY OPERATOR.



TWOSE OF TIVERTON LIMITED  
BLUNDELLS ROAD  
TIVERTON  
DEVON  
EX16 4JT

TELEPHONE NO. (01884) 253691  
FAX NO. (01884) 255189

All dimensions and capacities mentioned in this book are approximate. In pursuance of the company's policy of constant development, the right is reserved to depart, without notice, from any detail illustrated or specified in this book, without incurring the obligation to provide such modifications on the machine previously delivered.

No responsibility will be accepted by Twose Of Tiverton Limited for any injury, damage or loss arising from the improper use of or lack of maintenance of any machinery supplied by them or from any failure of the user to comply with all instructions published by Tractor or Loader Manufacturers, particularly with the regard to maximum load capacities, tyre pressures and stability, or with instructions and regulations pertaining to Tractor Cabs.



## RAM IDENTIFICATION

When ordering SEAL SETS, RAM PARTS ETC., please follow the simple guidelines below to ensure receipt of COMPATIBLE PARTS.

Examine the Ram in question at the GLAND NUT. It will be one of THREE TYPES.

TYPE 'A'

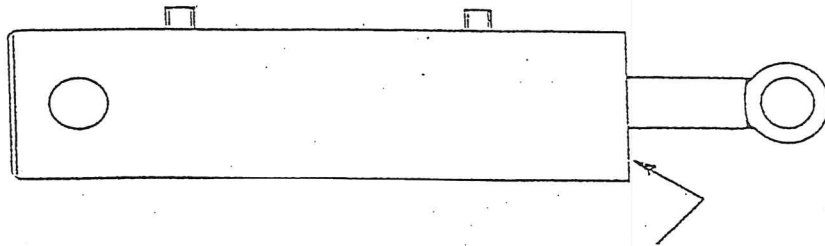

Gland nut internal and flush

TYPE 'B'

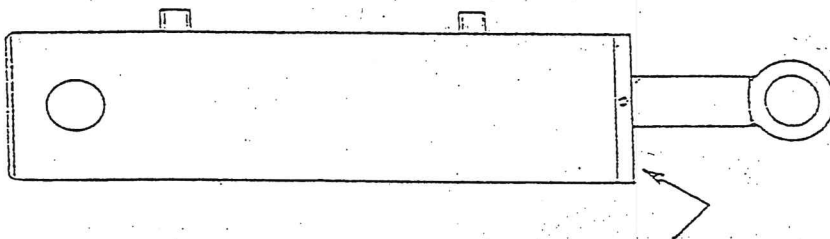

Gland nut exterior and same diameter as cylinder

TYPE 'C'

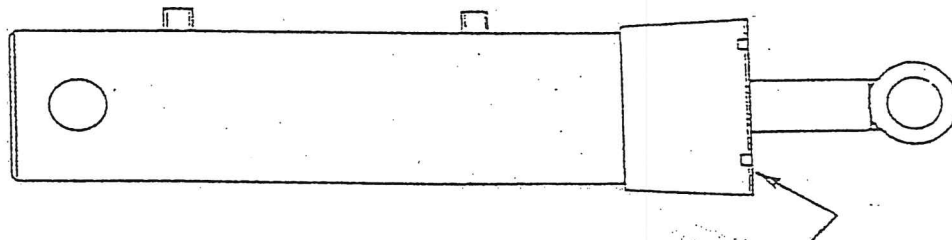

Gland nut is 'large cast Collar type'

WHEN ORDERING PARTS STATE WHETHER TYPE 'A', 'B' OR 'C'

This does NOT apply when a COMPLETE RAM is required, since all ram types are FULLY INTERCHANGEABLE.



# BOOM FLAIL MOWERS & HEDGETRIMMERS

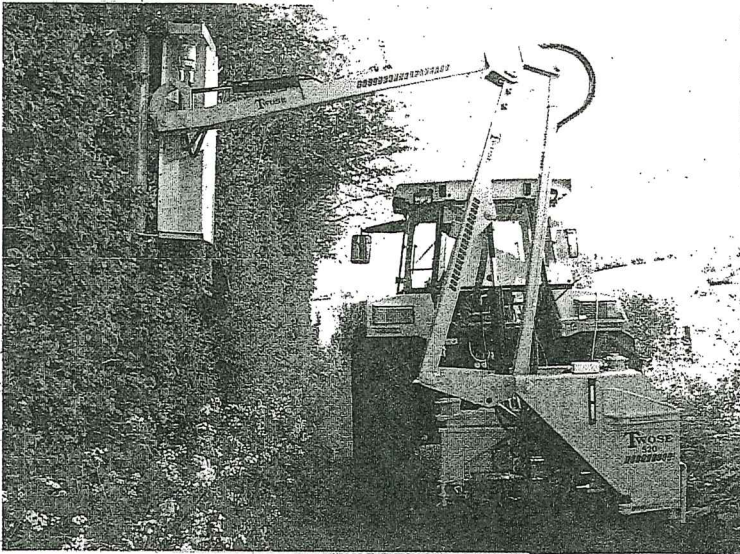

- . Various models for Contractors and farmers.
- . 14.6M (15ft 1in), 5.2m (17ft) or 5.8m (19ft) reach models left or right hand cut
- . Units have main lift float and head floatation.
- . Flail head of double skin design - with wire cutter, in widths of 1.2m, 1.25m or 1.6m.
- . Cable or electronic proportional joystick control.
- . Twin 'safety' vee belt drive from Motor to Rotor.
- . Power slew and hydraulic breakaway

MODELS	460
	520
	580

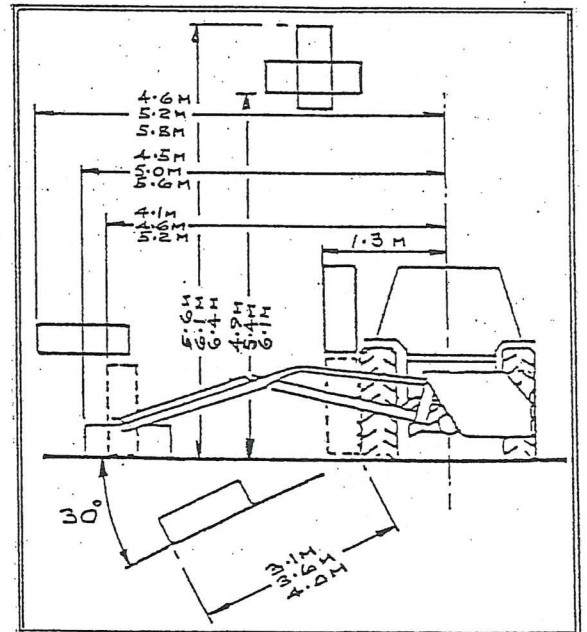
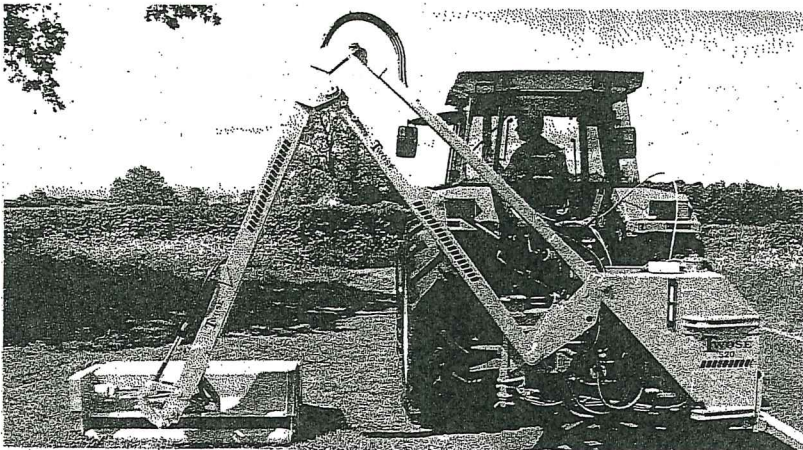

ALL DIMENSIONS ARE APPROXIMATE

TWOSE OF TIVERTON LIMITED  
 BLUNDELLS ROAD  
 TIVERTON, DEVON, EX16 4JT  
 TEL: (01884) 253691, FAX: (01884) 255189

# TWOSE



## INDEX

FLY SHEET	1
HEADER SHEET	2
RAM IDENTIFICATION	3
INFORMATION - PERFORMANCE	4
INDEX	5
SPECIFICATIONS	7
GENERAL INFORMATION	8
SAFETY NOTES AND WARNINGS	9
ABOUT THIS MACHINE	10
HEALTH AND SAFETY	11
NOTES	18
GENERAL INSTRUCTIONS	19
INTRODUCTION	21
TRACTOR SELECTION FOR 460,520 AND 580 MODELS	25
ATTACHING MACHINE TO TRACTOR	26
REMOVING BOOM FLAIL FROM TRACTOR	35
FLAIL TRIMMER - OPERATION INFORMATION	37
HYDRAULIC CONTROLS - CUTTING POSITIONS	41
TRANSPORTING	42
FLAIL HEAD	44
ADJUST ROLLER HEIGHT	45
HYDRAULIC OIL	46
ROUTINE MAINTENANCE AND 'LAYING UP'	47
OBSERVE - HEDGECUTTING OPERATIONS	48
HANDLING AND TRANSPORTING OF MACHINERY	50
PARTS LIST	51
TANK, ROCKER, PINS ETC.	53
SUB-FRAME AND STABILISERS	55
RETURN FILTER AND CONNECTIONS	59
FIRST BOOMS	61
SECOND BOOMS	63
TIE ARMS	65
FORWARD BOOMS	67
SIMPLE FORWARD BOOM	69
HEAD PIVOT AND LINKAGE	71
HEAD ASSEMBLY	73
FLAIL OPTIONS	78
BREAKBACK RAM	81
PRIMARY RAM	83
SECONDARY RAM	85
VALVE BLOCK (SEMI-INDEPENDENT MACHINES)	87
VALVE BLOCK (INDEPENDENT MACHINES)	91
MOTOR SPOOL VALVE (HEAD ROTOR DRIVE)	93

CONTROL LEVERS AND MOUNTING (T.M.C GREY CABLES)	95
5 BANK CONTROLLERS (GREY CABLES)	97
POWER PACK - PTO GEARBOX, PUMPS & FITTINGS	99
SET OF HOSES - 460R	100
SET OF HOSES - 460RI	101
SET OF HOSES - 520R	102
SET OF HOSES - 520RI	103
SET OF HOSES - 580R	104
SET OF HOSES - 580RI	105
ELECTRONIC PROPORTIONAL CONTROLS	106
ELECTRONIC CONTROL MACHINE	107
ATTACHING 'ELECTRIC MACHINE' TO TRACTOR	108
EMERGENCY-MANUAL CONTROL	113
HYDRAULIC CONNECTIONS	114
HYDRAULIC AND ELECTRICAL CIRCUIT	115
HOSE CONNECTION POINTS	116
SET OF HOSES FOR 580 RIEP	119
SET OF HOSES FOR 580 RIEL	120
VALVES AND COMPONENTS	122
FAULT FINDING CHART	125
CONTROL COMPONENTS	128
PUMP AND MOTOR (POWER PACK 2) STD. ON 526 AND 637	132
HYDRAULIC FITTINGS	134
HOSE CONNECTION POINTS	140
HYDRAULIC VALVE - ELECTRIC SWITCH CONTROL	141

## SPECIFICATIONS

### 460 Machine

Overall Height (machine folded for transport)	2.97m
Overall Width (machine folded for transport - taken from tractor's centre-line)	1.3m
Overall length of machine (less PTO shaft)	0.85m
Total weight of machine	1.2 T

### 520 machine

Overall Height (machine folded for transport)	3.18m
Overall Width (machine folded for transport - taken from tractor's centre-line)	1.3 m
Overall length of machine (less PTO shaft)	0.85m
Total weight of machine	1.28T

### 580 Machine

Overall Height (machine folded for transport)	3.35m
Overall width (machine folded for transport - taken from tractor's centre-line)	1.3 m
Overall length of machine (less PTO shaft)	0.85m
Total weight of machine	1.32T

## AIRBORNE NOISE EMISSIONS

The equivalent continuous A - weighted sound pressure level at the workstation (tractor seat) does not exceed 74dB (A). This value was achieved cutting hedges using a Dawe 1405C Sound Meter (BS 3489) on a 3090 Massey Ferguson Tractor complete with M/F Safety Cab.

Note - Dimensions are approximate and will vary from tractor to tractor.



## GENERAL INFORMATION

NOTE:- The provision of this information is a requirement of the Health & Safety at Work Act 1974.

NOTE:- This handbook has been designed to help the operator and service/mechanic to use and understand the machine fully, safely and efficiently, bearing in mind the Health & Safety requirements and the new CE requirements which come into force from January 1st 1995.

NOTE:- The handbook/manual will be supplied in a waterproof plastic outer cover to prevent damage from rain, condensation etc. The cover of the handbook will include its own part number, which includes information as to machine type and issue date of manual in question.

### DANGER

NOTE:- It is very important that the handbook/manual has been read thoroughly - throughout, and is completely understood before attempting to attach or use machine in any way.

CAUTION: When ordering spares, please state clearly:-

- (a) Machine type and model No.
- (b) Part No. of component.
- (c) Description of component.
- (d) Quantity required.
- (e) Full address to which spares are to be sent.
- (f) Method of delivery required.

CAUTION:- Always insist on genuine and correct spare parts.

NOTE:- Further copies of this handbook/manual can be obtained from:-

TWOSE OF TIVERTON LIMITED  
BLUNDELLS ROAD  
TIVERTON  
DEVON  
EX16 4JT

TEL: 01884 253691  
FAX: 01884 255189

## SAFETY NOTES AND WARNINGS

Throughout the handbook the following sub headings are used to draw attention to various points of importance.

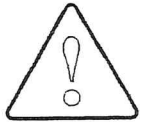

**DANGER  
WARNING**

This is to draw attention to very important instructions which MUST be followed precisely to avoid injury or death.

### CAUTION

This is used to draw attention to instructions which MUST be followed to avoid damage to operator, machine, process or the environment.

### NOTE:-

This is used to highlight points used for supplementary information.

## ABOUT THIS MACHINE

This is a Hedge Trimmer of the type known throughout the agricultural industry as a "Flail type" Hedgetrimmer.

It is intended to be attached to an agricultural vehicle by means of the "Three-point-Linkage" couple-up system, which in turn is locked into position (to prevent movement between tractor and Hedgetrimmer) by means of a pair of adjustable tie arms - forming an 'A' frame to ensure a rigid attachment/lock system.

The purpose for its production and its sole intention is to cut/trim hedges, banks, verges etc.

AT NO TIME must this machine be used for anything other than, or to do any job - other than that for which it has been designed (see note above).

NEVER USE JIB - ARMS AS A CRANE

## HEALTH AND SAFETY



DANGER  
WARNING

Never attempt to assemble, couple up, or operate machinery until you understand fully the functions, controls and safety precautions required, as shown in the operators manual.



DANGER  
WARNING

Always follow tractor safety operations and instructions VERY carefully.  
NEVER TAKE RISKS



DANGER  
WARNING

NEVER LEAVE TRACTOR SEAT WHILST ENGINE - OR MACHINE IS RUNNING



DANGER  
WARNING

NEVER USE HEDGETRIMMER JIB/BOOM ARMS AS A CRANE IN ANY FORM



DANGER  
WARNING

## HEALTH AND SAFETY CONTINUED

It may be found necessary to stabilise whole unit once coupled together - by ballasting tractor rear wheels and/or fitting counterbalance weights to tractor.

Tractor rear wheels could also be set out to a wider track setting as a method of increasing stability. (Check with agent).

### CAUTION.

Be aware of warning stickers and instruction stickers on machine as care must be taken and instructions obeyed.

### CAUTION

Contact your dealer should you need advice, assistance, or if you do not understand the manual or machine. "NEVER ASSUME" - if not sure - ASK.

### CAUTION

Machine **MUST NOT** be altered or modified in any way - without permission - No liability will be accepted in respect of a machine that has been modified without manufacturers permission.

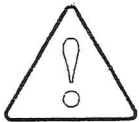

DANGER  
WARNING

Never drive machinery at speeds that could cause danger to other persons or properties, or in a manner that may cause accidents.



DANGER  
WARNING

Never attempt to Service/adjust or work on any machinery in an unsupported state.

## HEALTH AND SAFETY CONTINUED

For Example:-

Any three point linkage mounted machinery  
Front Loaders  
Digger Booms  
Hedgetrimmer booms etc. etc.

Always ensure that machinery is safely supported and propped in position.



DANGER  
WARNING

Always ensure that the wheels of any wheeled implement/machinery are 'chocked' firmly and implement will not move, before attempting to 'service' or 'work on' in any way or form.

### CAUTION

Always "SWITCH-OFF" tractor engine before attempting to carry out adjustment or service repairs and inspections, on machinery.



DANGER  
WARNING

Always be aware of your surroundings - and operate machinery accordingly. Beware of confined-tight areas, low height restrictions, buildings and overhangs etc. Also drive and operate bearing in mind weather conditions such as sun, rain, ice, snow, wind etc. [Make allowances in all situations].

### CAUTION

Hedges, banks etc. must always be 'inspected' before actual cutting/trimming commences - in order to find any unusual, large, unexpected or dangerous objects. Any objects found that may cause a danger or risk must be removed.

### CAUTION

Never operate machine in a reckless or uncaring manner. Respect other road users and be patient.



## HEALTH AND SAFETY CONTINUED

### HIGHWAY USE

When operating machinery on the Highways the "Local Highways Department" should be consulted for approval and notification, as rules and regulations vary from local authority area to area.

But the Highways Department regulations must be followed.

NOTE:- In general it is expected that the "Tractor/implement will follow (WITH) the flow of traffic" - but local Highway rules will confirm this.

Always use 'STOP'-'GO' boards or whatever system Local Highways Department advise, and ensure these are positioned correctly in relation to machine operating area.

Have respect for 'passing' traffic and keep 'passing' lane free from obstruction.

Allow time for walkers and cyclists to clear site. Also when using on the Highway consult the 'Lighting Regulations' for correct procedures.

### CAUTION

Never carry "passengers" on machinery or on tractor.

Ensure bystanders/onlookers are kept well away from operational area of apparatus.

NOTE:- NEVER ALLOW ONLOOKERS/BYSTANDERS TO STAND IN FRONT OF CUTTER HEAD - IN LINE WITH FLYING DEBRIS.

A sideways and rearward NO-GO area should also be kept (see sketch below).

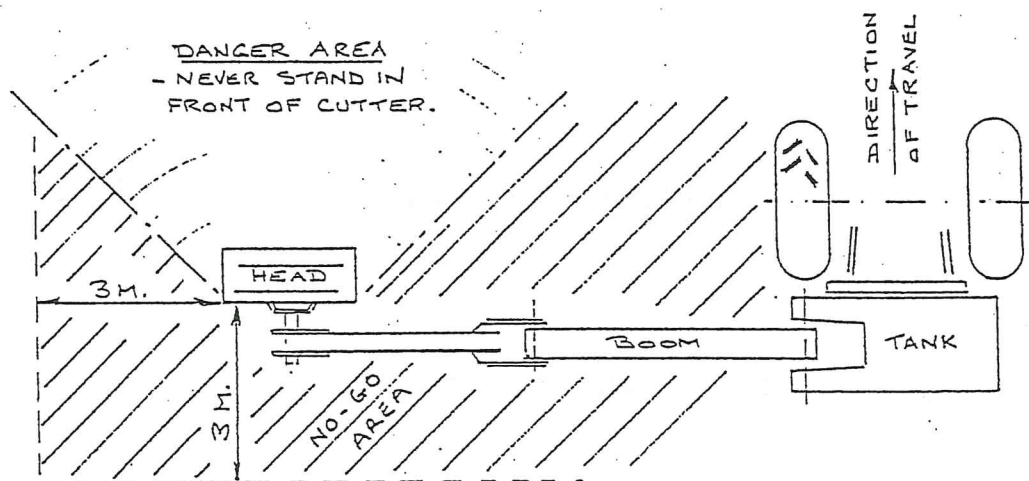

## HEALTH AND SAFETY CONTINUED

### CAUTION

Never operate cutting rotor with blades looking towards operator or towards others. Cutters must always be operated towards hedge or bank/verge etc.

### CAUTION

Never walk underneath the machine for any reason especially if unit is still operating.

### CAUTION

#### 'PARKING UP' MACHINE

When machine is being removed from tractor linkage and being 'parked up' it is essential that a good firm base and level site be found.

Always chock and prop machine to ensure a good firm position to leave parked. Ensure that stand legs of machine are correctly locked into position.

### CAUTION

Never allow children to play on, or around, parked machinery.

### CAUTION

Never wear loose fitting or ragged clothing which could get caught in machinery or controls.



DANGER  
WARNING

Always ensure safety screens are fitted into position to protect operator from flying debris.

### CAUTION

Ensure visibility is clear through cab-screens at all times.



## HEALTH AND SAFETY CONTINUED

### CAUTION

Ensure workstation controls, Joysticks, (Cable levers) etc are positioned correctly to suit operator, and not getting in the way of other driving functions.

Make sure controls do not obstruct entry and exit to cab.

### CAUTION

Always dispose of discarded or worn out parts thoughtfully - by disposing of them in an approved and specified legal scrap site, bin or skip.

### CAUTION

Worn out and spent waste oil, grease and other obnoxious substances must always be disposed of in suitable and legally approved dumping containers suitable for the waste in question.

### CAUTION

Ensure booms are folded onto rubber buffers (which are fitted) and that the whole machine is folded in as close to tractor as possible whilst transporting.

--- \* ---

### CONTROL LEVERS (CABLE MACHINES) (AUTOMATIC SAFETY).

The control levers which operate the hydraulic boom cylinders on cable control machines will automatically centralise themselves in the CENTRE-OFF position as soon as control lever is let go, thus preventing any chance of unwanted movement or overrun of booms.

Cutting heads are equipped with a built-in "wire cutter" member to prevent wire getting wrapped and tied onto rotor.

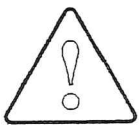

DANGER  
WARNING

## HEALTH AND SAFETY CONTINUED

Great care must be taken when attaching Hedgetrimmer to tractor linkage due to having to actually position oneself between tractor rear and Trimmer in order to connect attachment pins, P.T.O etc. etc.

### CAUTION

#### Flails to Rotor

Special bolts are used to attach flails to rotor these are M16 x 80 (10.9) grade and have fine pitch threads.

NOTE: - this bolt specification must not be changed.

### JOYSTICK CONTROL (ELECTRIC MACHINE) (AUTOMATIC SAFETY)

The electronic-proportional control model of Hedgetrimmer, which has a single joystick as controller, will also go automatically to the "CENTRE OFF" position immediately the joystick is released - cancelling all functions.

[JOYSTICK IS NATURALLY SPRUNG LOADED TO NEUTRAL -  
CENTRE OFF POSITION]

### CAUTION

#### ELECTRIC CONTROLS

The electronic controls, for either 'switch control' or 'Joystick control' Trimmers should be kept in a dry, damp free area whilst machine is 'off' tractor and being stored.

---\*---

NOTES

AMENDMENT

DATE

DETAILS

## GENERAL INSTRUCTIONS

### DANGER WARNING

1. Before attaching any machine to a tractor or loader make sure that implement is still standing firmly on good solid - level site as it will be, providing unit was previously parked correctly.  
- Check that any wheels are 'chocked' correctly and that supports/props are in position where necessary to prevent booms etc. dropping.
2. Before and during the manoeuvring of the tractor or vehicle in order to attach machinery/implements, - make sure that No other persons are in the vicinity. Keep other persons well clear and make known your intentions, all the while keeping a sharp lookout whilst reversing and aligning machines for coupling up.
3. Always secure tractor into selected position by ensuring that brakes are applied correctly in order to prevent vehicle moving off on its own to cause injury and damage.
4. Make sure that the lift arms and top link ball ends of the tractor are properly fitted to the machine/implement by using correct adaptor sleeves where necessary, and that retaining pins of the correct type are used on all three point linkage points. Secure pins with relevant pin and ring assembly.
5. If the machine is of the drawbar type - check that the hitch on the tractor is in good condition and that the hitch pin used is of the correct size and type, and is properly secured when fitted.
6. Should it become necessary to make any adjustments or service on machine while raised on the tractor linkage, or raised on a front end loader - trestles or suitable supports MUST be positioned to support machine to prevent accidental dropping of lift arms, loader arms or mechanical failure.  
[MACHINE MUST ALWAYS BE PROPPED AND CHOCKED]
7. Never attempt to work on, adjust or service repair machinery of any kind whilst it is still running or working. Always stop the machine and **STOP THE TRACTOR ENGINE** - before any service/repairs begin.  
(**SWITCH OFF TRACTOR ENGINE BEFORE LEAVING TRACTOR SEAT**)

8. In transit always use transport stays or locking devices where provided.  
If, as in the case of some longer machines, the unit is transported lengthways - make sure that the front of the tractor is suitably ballasted to maintain stability.  
A method of achieving this would be to add suitable weights to a correctly specified and fitted front weight frame.
  
9. Always use machines in a sensible and reasonable manner and do not attempt to use them in work for which they are not intended. Avoid overloading and abusing them as this can cause damage to machine and tractor and can be very dangerous.
  
10. When unhitching/detaching a machine from a tractor three point linkage or from a front end loader ensure that any stands or legs are securely positioned and that the machine is parked where it will not be a safety hazard or cause annoyance to others. Make sure that chosen 'parking site' is a firm and level site.
  
11. Carry out regular periodic maintenance. - Always with safety in mind.
  
12. Ensure regular maintenance procedures are maintained for the lifetime of the machine.
  
13. **HEALTH AND SAFETY RULES AND REGULATIONS MUST BE ADHERED TO IN ALL AGRICULTURAL RESPECTS.**

--- \* ---



## INTRODUCTION

1. The Twoose range of Boom Flail Trimmers has been designed with both the farmer and the contractor in mind - which has resulted in a boom flail with a very high specification - with many features not found on other machines.
2. The construction is of welded steel fabricated assemblies - with many and varied options available covering such things as controls, hydraulics, heads, booms etc. The cutting head is of a 'double skin' construction.
3. The cutting flail blades offered are:-

(a) Heavy, double-edged design, one piece.

- For UP or DOWN cutting

- Suitable for all types of conditions and growth.

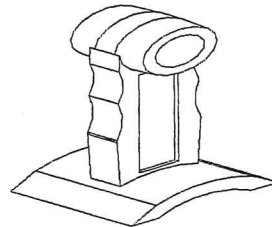

(b) Back to back rigid, one piece blade, in pairs.

- For UP or DOWN cutting, grass mowing and trimming.

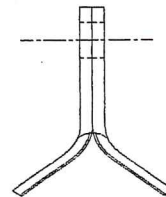

(c) Back to back on shackle, in pairs.

- For UP or DOWN cutting of grass and mowing.

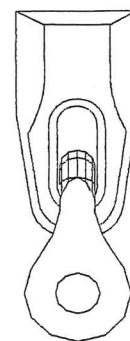

(d) Heavy single edge blade flail (twisted pattern).

- For grass cutting and hedge trimming

- Cuts one direction only



(e) Boot Flail (on shackle).

- For grass cutting and hedge trimming

- Cuts one direction only.

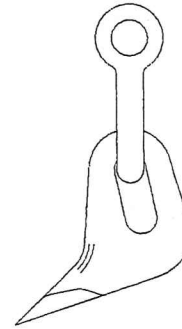

4. The cutter head design is of a double skin construction for greater strength and longer life. The drive is by Vee belts from Hydraulic motor-to-rotor, with the drive completely contained within the width of head for a cleaner cut.
5. Twin Vee belts take the drive from Motor to Rotor - giving a reliable drive with the anti-shock protection that a belt system provides.
6. A hydraulically powered breakback system is built into all models. This is primarily to protect components when encountering obstructions, but also acts as an aid when cutting in difficult and awkward corners.
7. Two parking stand legs are fitted to machine - one of which is of a folded plate construction and is situated at outer face of hydraulic tank. The second leg is a 'T'

shaped assembly which is located on the linkage attachment frame. Both stands stay with machine when working, being stored in a 'reverse position'.

#### ON CABLE OPERATED MACHINES.

8. A float system is included for the cutter head - to allow unit to follow the ground contours when bank/verge mowing. The float position is found simply by putting control valve into 'detent' position.
  
9. Hydraulic hoses on machines have been kept as unobtrusive as possible - few are visible. The booms have been designed to allow the hoses to run through them.
  
10. Forward looking booms are available as options to give a mid-cut position (alongside tractor) as opposed to the in line geometry of standard booms.



11. Float control - Cable operated machine.

These machines have a relief valve in system to main Primary Ram which prevents unit being powered into floor, causing undue pressures. This acts as a safety feature for the whole machine - useful when cutting verges, banks etc.

(Relief only on the drop side of cylinder)

The same valve slice also has a detent facility for head flotation.

Float control - Electric machines

The electric machines have a relief valve in the system to the main primary ram which prevents unit being powered down into the floor causing undue pressure. (Relief only on the drop side of cylinder).

Hydraulic 'head-float' also controlled by ON-OFF toggle switch.

Also these machines have a float system which is switched ON-OFF by means of a simple toggle switch.

The float pressure is variable over a controlled range, setting is by a rotary potentiometer.

12. Machine operation is controlled remotely by either cable via lever, or electronically through a proportional valve system - with single joystick controller. On all fully independent machines direction of cutter head rotor is controlled by a cable.

## TRACTOR SELECTION FOR 460 AND 520 BOOM FLAILS

for 460:-	Tractor size must be a minimum of 45kW (60 HP)
for 520:-	Tractor size must be a minimum of 48kW (65 HP)
for 580:-	Tractor size must be a minimum of 48kW (65 HP)

The tractor must be equipped with a power take off shaft which must run at 450 R.P.M during operation.

The P.T.O shaft should run clockwise when looking at the rear of tractor and ideally should be 1 3/8" S.A.E - 6 spline type shaft enabling a standard P.T.O shaft to be fitted.

Tractor must have counterbalance weights fitted if necessary (on approved mountings) and/or ballasted wheels may be found an advantage to ensure unit is stable.

Tractor rear wheels could also be set at a wider track setting to cure stability problem - contact agent for advice.

Four wheel drive tractors - with the extra weight inbuilt, plus larger front wheels - is an advantage in keeping machine stable.

## ATTACHING MACHINE TO TRACTOR

### IMPORTANT:-

Ensure machine is parked on a firm and level site without any bystanders or onlookers.  
Read and understand the general instructions and Health and Safety of this manual.

#### 1. NOTE:- FOR PIN TYPE LOWER LINKAGE EYES ONLY:-

Remove spring pins, lift pins and spacers as supplied with Hedgetrimmer from lower link positions of linkage frame.

Slowly and very carefully reverse the tractor towards the machine linkage frame.

With care - ensure that tractor lower link ball eyes fit between lower jaws of linkage frame and that pin holes are aligned.

#### SWITCH OFF TRACTOR ENGINE AND ENSURE HANDBRAKE IS ON

With holes of tractor lower link eyes in line with lower jaw holes of frame - the lower linkage pins should now be refitted - with spacers 'in position - on pin, between jaws and outboard'

Spacer is provided to prevent side movement of link arms.

Secure lift pin into position using the 7/16" dia pin and ring assembly.

#### NOTE:- FOR AUTOMATIC QUICK CROOK-ON LOWER LINK ONLY:-

- 2 Remove spring pins, lift pins and spacers as supplied with Hedgetrimmer from lower link positions of linkage frame. Then reassemble lift pin, spacer together with tractor lower link ball end eye - all onto lift pin (between ears of frame) - with spacers to the outside. Then secure into position using 7/16" diameter pin and ring.

Next slowly and very carefully reverse the tractor towards the machine linkage frame.

With care - ensure that tractor lower links fit between lower jaws of linkage frame and are aligned with relevant ball eyes now already on lower lift pins.

Raise tractor lower link arms to a position that allows the ball to engage correctly into its own housing in arm.



3. The adjustable 'A' frame - stabiliser arms should now be set to required length to suit tractor.

The main 20mm diameter locating pin - through both assemblies should be removed after first disconnecting its 7/16" diameter lock-pin and ring.

Next slacken off the M20 setscrew (clamping both halves together)

The pair of stabiliser arms can now be telescoped upwards/forwards to allow the top link coupler to be fitted to the tractor top link position. Secure upper end of stabiliser to tractor top link point using tractor top link pin and spring pin.

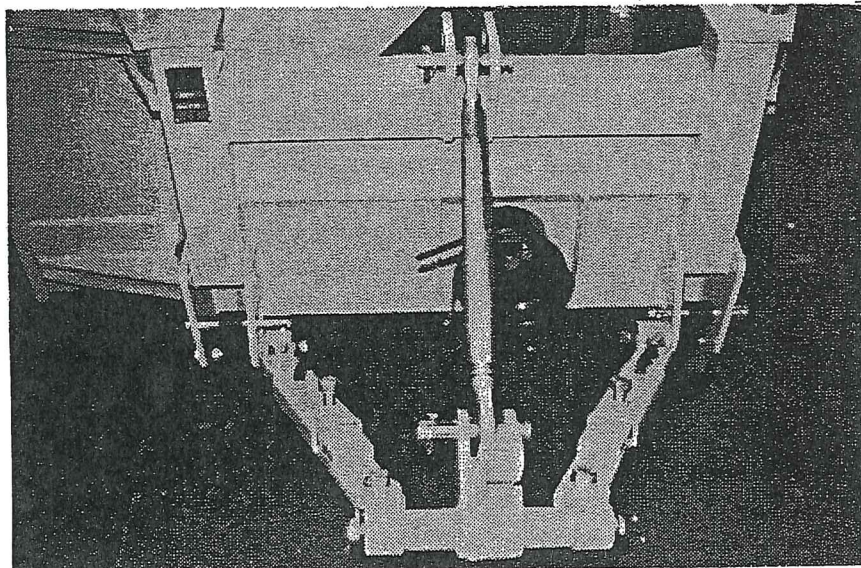
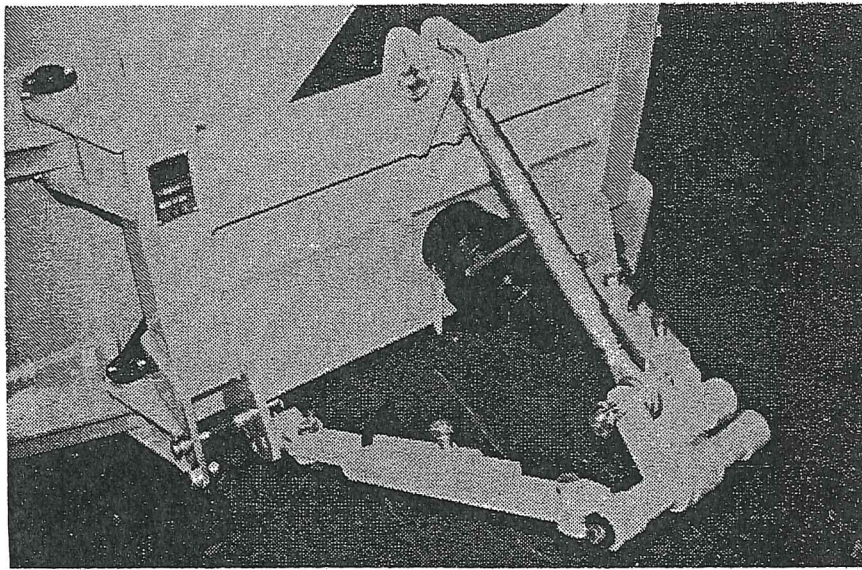

The top link stay - between Hedgetrimmer and stabiliser frame may have to be lengthened/adjusted to suit.

## START-UP TRACTOR

Raise whole machine on linkage until a height is reached which gives a reasonably horizontal path for the P.T.O shaft and approximately 300mm.

With machine at this height setting the 20mm diameter locating pin for stabiliser arms should be fitted through pair of nearest matching holes, and secured with 7/16" pin and ring (both arms). - Ensure chosen setting is same on both arms.

Then tighten M20 setscrew to each stabiliser arm - to lock together.

Lower three point linkage to allow weight of machine to be taken on stabilisers.

Tractor lower linkage check chains assemblies should now be tightened to make sure tractor arms are locked and machine is positioned centrally at rear of tractor.

Top link should be adjusted to ensure hedgetrimmer is upright.

4. Check the P.T.O shaft length.

When connected from tractor to machine it should engage by 1/3rd of the total shaft length, i.e. male part should be halfway from the end to fully bottomed out. Do not use the machine until this has been cut to the correct length.

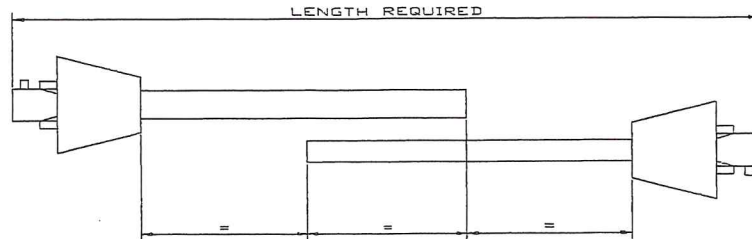

5. Fit the P.T.O shaft.  
Ensure the shaft is correctly fitted to the correct splines - at both ends.  
Fit the anti-spin chains of P.T.O guard to a rigid non turning assembly.

6. Remove both stand legs - one on sub-frame and one on tank.  
The sub-frame mounted stand leg is to be stored where and as indicated below.

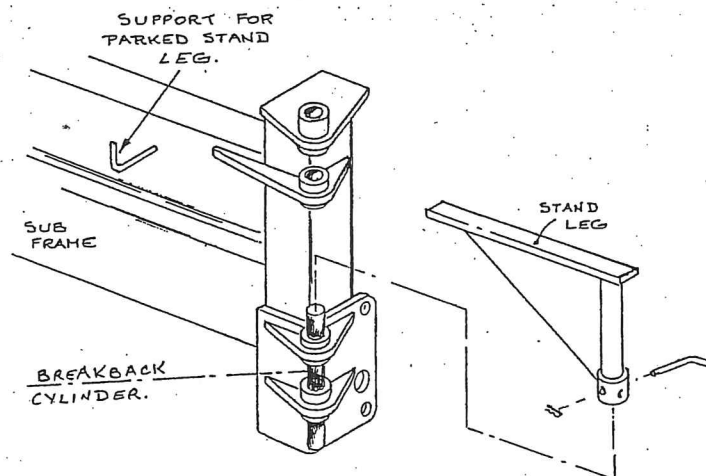

The plate stand at outer face of tank, once removed - should be inverted and located back onto same mounting pins and secured by same 7/16" lynch pins.



Tank stand leg can be used as a warning triangle to warn traffic etc. near the worksite (use in the position shown in left hand drawing).

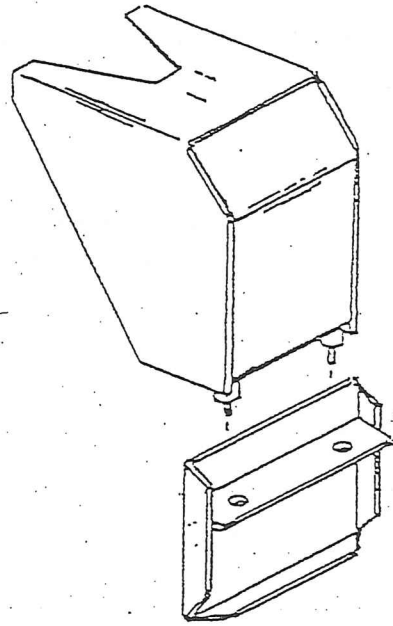
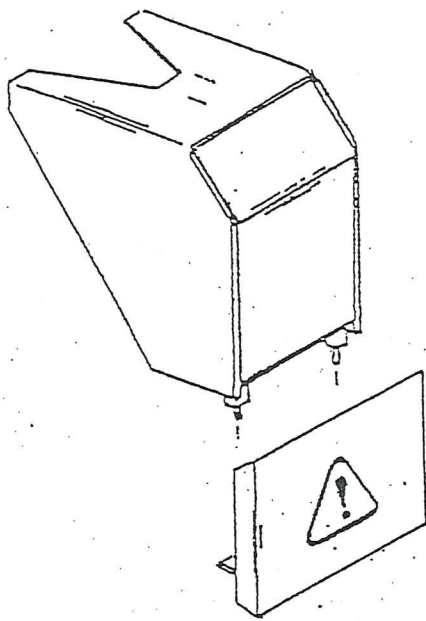

DANGER  
WARNING

7.

The mesh safety screens should now be cut and fitted. They are designed to be fitted to the cutting head side of tractor cab (i.e. for left-hand cut machines to left hand side of cab). Bolts, nuts and washers are supplied for fixing purposes.

- All glass screens on the relevant side of cab must be protected.

8.

Fix valve control handles into position:-

Control levers are supplied bolted together as a unit complete with a support leg to slot into a bracket supplied for fitting to the tractor.

Depending on model there may be 4, 5 or even only one controller in the set. The locating bracket should be positioned on the inner wing face of the tractor cab in a suitable position for easy operation. Bolts, nuts and washers are supplied for fixing.

It is suggested that for four and five bank controller sets the bracket is fitted to the left-hand wing for left-hand cut machines and right-hand wing for right-hand cut machines.

In the case of single-bank controllers, it is suggested that the bracket is fitted to the opposite side for the control of the cutting direction and that the joystick mounting bracket is fitted to the cutting side (both brackets are however the same). Once the bracket is fitted to the cab side the controller unit can be lowered into the brackets slot and secured by tightening screw 'X' (clockwise).

Drawing shows a bank of five controllers to be fitted to a support leg and to be fitted to a locating bracket to be fitted to the inner wing for left-hand cut machines.

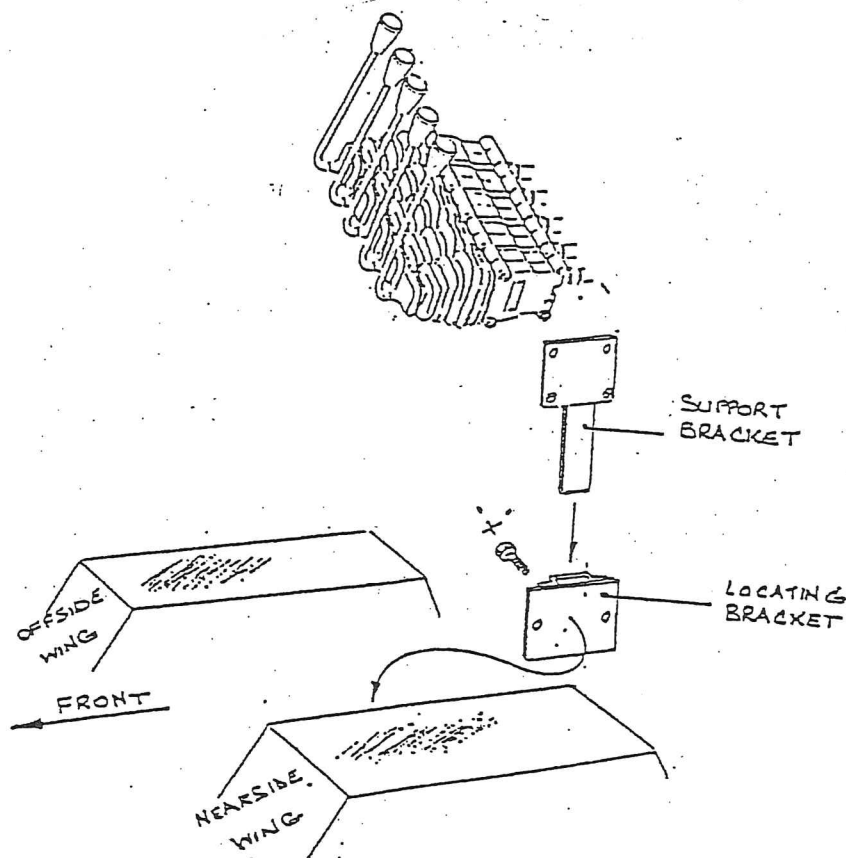



9. **IMPORTANT** - check the level of oil within the tank, it should be halfway up the sight glass.

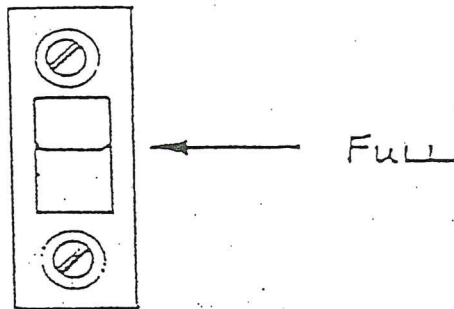

10. **IMPORTANT** Ensure that the ball-valve at the base of the tank is in its 'ON' position.

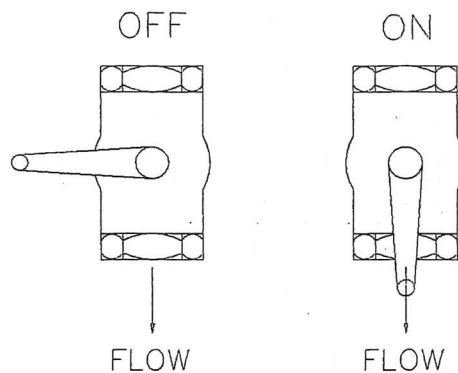

Never use machine with lever in OFF position.



**DANGER  
WARNING**

#### P.T.O Engagement

The tractor power Take Off can now be engaged - **CAREFULLY**. Check that P.T.O. is running correctly and that guard is not spinning.

Oil will now be pumping within the hydraulic system.



DANGER  
WARNING

### CONTROL LEVER OPERATION.

Test the hydraulic valves by operating the control handles. This should be done with great care until the operator gets a good 'feel' for the controls and feels competent.

Each control lever is individually labelled as to which operation it controls.

See drawing below.

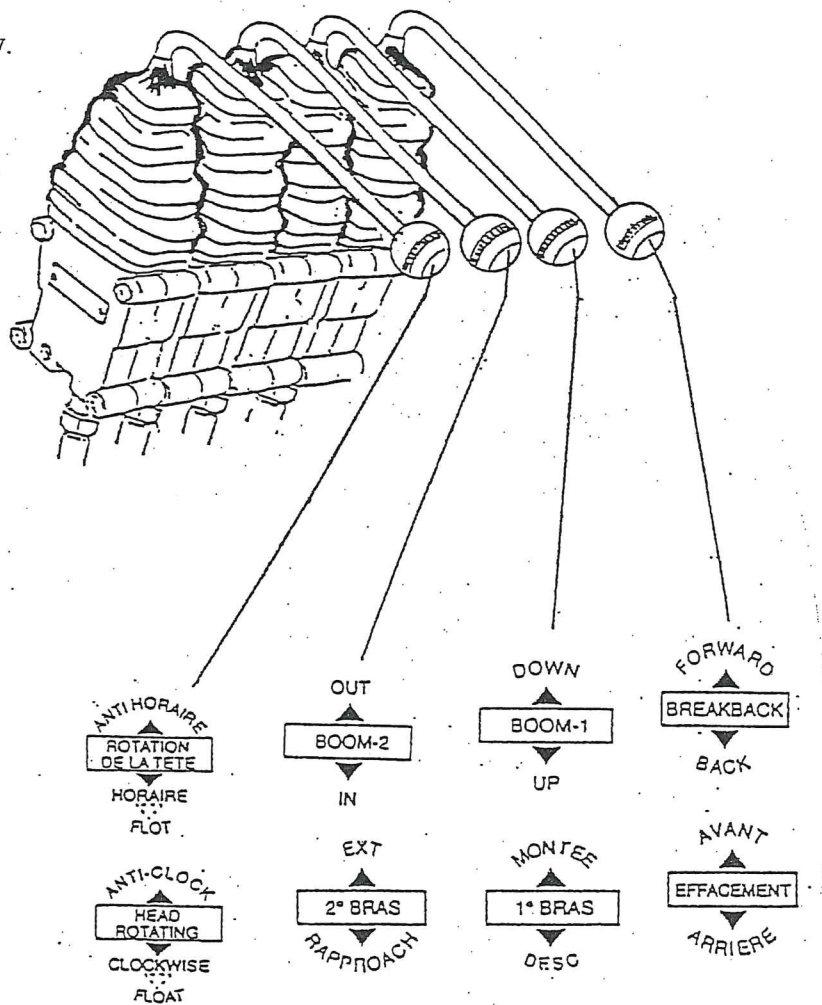

NOTE:-

The above formation of assembly can be changed to suit individual requirements.

NOTE:-

The valve slice sections are assembled in the following formation:-

MAIN BOOMS  
VI SPOOL VALVE

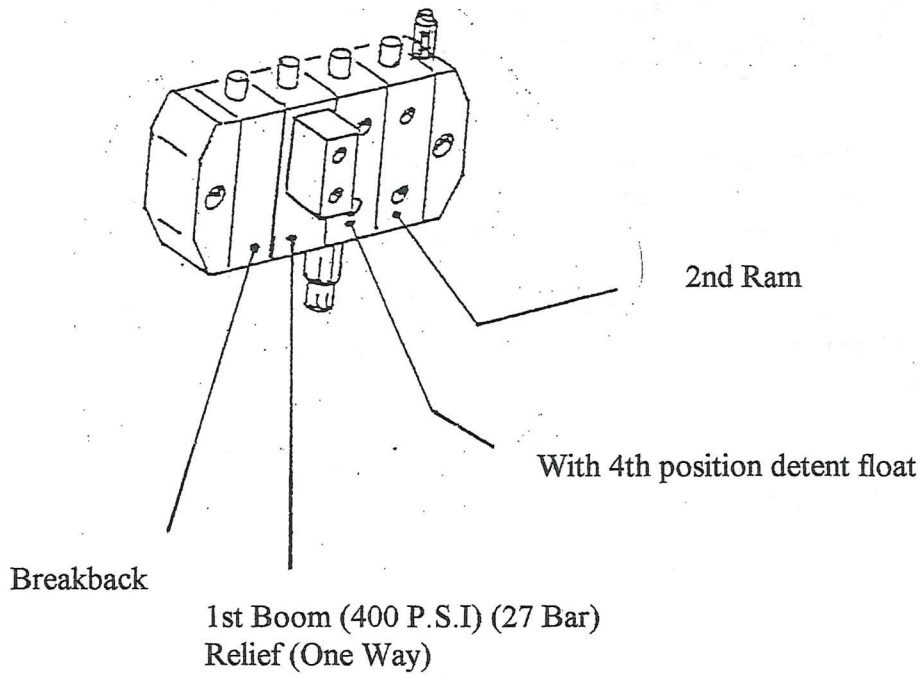

## REMOVING BOOM FLAIL FROM TRACTOR

1. Select a good clear, level and firm site on which to detach and store the machine.
2. **IMPORTANT**  
Use the hydraulics to lower the head onto the ground horizontally (as if you were cutting grass).
3. Disengage the P.T.O. drive -  
**STOP THE TRACTOR ENGINE.**
4. Take the 'T' stand leg from its 'stored' position and put it into its 'down' position, securing it with the lynch pins provided. (If this information is unclear refer to page 31)

Note: Long-foot of 'T' stand **MUST** be furthest from tractor to ensure maximum stability.

5. Similarly - plate stand leg should be removed and replaced in its 'down' position also. Secure with lynch pins provided.
6. Slacken both M20 setscrews on stabiliser arms, remove the 7/16" diameter lynch pins from the stabiliser locating pins, and remove pins. It may be necessary to slightly raise three point linkage to 'free' pins, for removal.

Lower hedgetrimmer so stands are on the floor, by means of lowering tractor 3 point linkage. (Top link may have to be adjusted to ensure trimmer is upright and safe).

When you are sure that trimmer is properly settled and safe on its stands, operate boom '1' lever to release hydraulic pressure from ram.

NOTE:- If the machine is semi-independent (one pump) you may have to stop tractor engine to facilitate this.

Disconnect top link assembly from stabiliser end.

Uncouple stabiliser 'A' frame from tractor top link position - by removing 7/16" lynch pin and tractor top link pin.

7. Remove control handles from tractor and stow on trimmer - Note, for semi-independent machines - 2 hoses (supply and return) must be uncoupled from tractor aux. ports and stowed on machine.
8. Disconnect Power Take off shaft and anti-spin chains (tractor end).
9. - FOR PIN TYPE LOWER LINK ARMS:-  
Remove 7/16" linch pins from lower lift pins and remove pins from linkage.  
  
- FOR QUICK HITCH CROOK ON ARMS:-  
Release crook lock lever on lower link arms and lower/drop arms away.  
  
Tractor linkage arms are now free of Trimmer.
10. Draw tractor slowly away - Many operators stop about 300mm (12") away to double-check that tractor and machine have completely parted company and that no connections or couplings have been forgotten for any reason.  
  
Safety screens can now be removed if so desired.
11. Replace location pins back-through arms of stabiliser assembly and secure in position with 7/16 linch pins.
12. Re-connect top link bar assembly back onto stabiliser with pin and linch pin provided.
13. Replace lower linkage pins back into relevant positions on mounting frame and secure with 7/16 diameter linch pins.
14. Make sure tractor top link pin is replaced and secured with 7/16" linch pin.

**VERY IMPORTANT**

**FLAIL TRIMMER**  
**- OPERATION INFORMATION**

The vehicle driver should be conversant with all tractor controls and capabilities.

It is always advisable for the tractor driver to practice the controls and operations of the Flail Trimmer prior to setting off into work.

The speed of operation of Trimming will depend on the size, quantity, and type of growth to be cut. A slow speed to suit the conditions, should be selected, ensuring that engine speed gives a P.T.O speed of 450 R.P.M for general use.

This 450 R.P.M (P.T.O) is recommended for best trimming results and performance.

Variation from this recommended R.P.M should be kept to a minimum and never at any time should P.T.O R.P.M exceed 540 R.P.M.

**ROTOR ROTATION - DIRECTION:-**

Depending on the type of hedge to be cut, an option of rotation direction is offered. The 'upward' cut is recommended for trimming grass, light growth such as one/two years growth.

**DOWNWARD CUTTING IS NOT RECOMMENDED** - and should only be considered for really heavy - large diameter growth cutting. Even then, it is important that down cutting be limited to minimum, very short periods only.

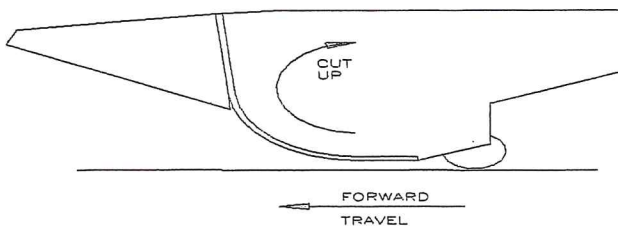

**FORWARD  
TRAVEL**

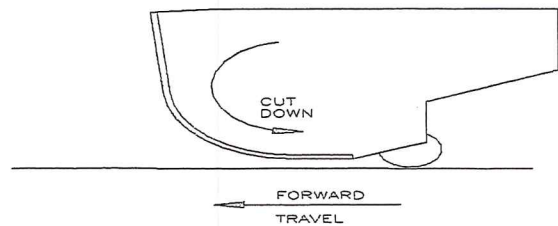

**FORWARD  
TRAVEL**



DANGER

VERY IMPORTANT

It is very important that motor spool and motor spool control lever works one direction, from centre 'OFF' position to selected 'rotor cut' direction 'ON' position. Giving rotor - one direction of cut only, and an 'OFF' setting. Thus eliminating chance of going from cut-up to cut-down in one movement of controller and blowing the system.

Only by altering LOCK-LEVER setting can direction of control lever be changed.

VERY IMPORTANT (DANGER)

DANGER - NEVER CHANGE DIRECTION OF ROTOR CUT WHILST ROTOR IS STILL TURNING.

DANGER - ALWAYS ALLOW ROTOR TO STOP SPINNING COMPLETELY BEFORE CHANGING CUT ROTATION (DIRECTION)

IMPORTANT

When leaving factory the machine will be set for 'standard' 'upward' rotor cutting - unless specifically requested.

DANGER  
IMPORTANT

In heavy going - cutting large diameter growth with front cowling removed, the rotor MUST ALWAYS CUT DOWNWARDS AT FRONT. At no time should the rotor be cutting upwards at front with front cowling removed.

ROTOR CUT DIRECTION MUST NEVER BE CHANGED IN ONE MOVEMENT

The controller lever head for motor spool control is designed with a "LOCK-ARM LEVER" which must be operated as follows:-

NOTE:- FOR MORSE CONTROLLERS ONLY (RED CABLES)

FOR DOWNWARD CUTTING OF ROTOR

Position "LOCK-ARM" forwards and downwards (see drawing page 42)  
Control lever will now only move from neutral 'OFF' position to 'AWAY', down position only.

To change to UPWARD CUTTING OF ROTOR

ENSURE ROTOR IS NOT ROTATING AT ALL - MUST BE TOTALLY STOPPED.

Move 'LOCK-ARM' rearward - fully (see drawing below)

Control lever will only move from neutral - OFF position to 'TOWARDS' up cut position only.

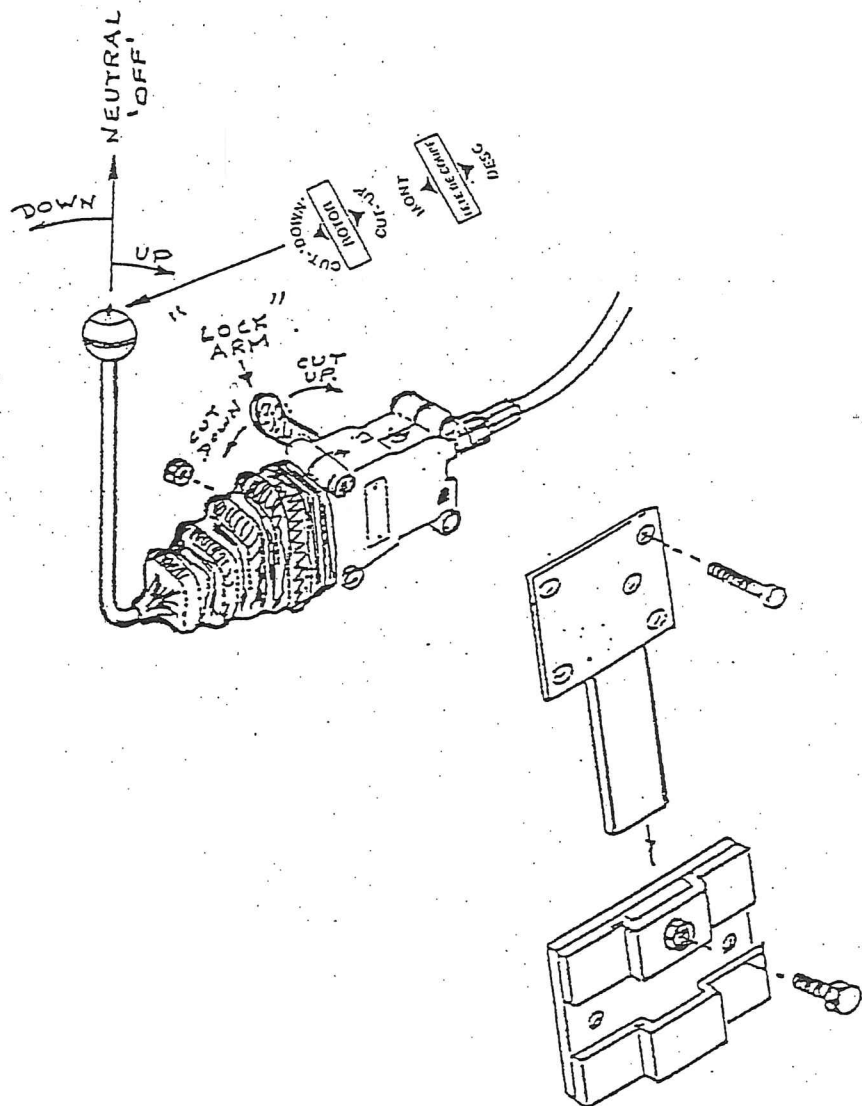

NOTE:-

FOR T.M.C CONTROLLERS ONLY (GREY CABLES)  
(- FOR DOWNWARD CUTTING OF ROTOR)

Position long end of pin through "rotary control spindle" forwards and downwards. (see drawing following this text)

Control lever will now only move from NEUTRAL 'OFF' position to 'AWAY' - down position only, thus giving a down-cut system.

--- \* ---

To change to UPWARD CUTTING OF ROTOR

ENSURE ROTOR IS NOT ROTATING AT ALL - MUST BE TOTALLY STOPPED (AT A STANDSTILL)

Turn rotary control spindle via - pin through shaft to a position where long end of pin is rearwards - horizontally. This will permit lever to travel from NEUTRAL-'OFF' position to 'TOWARDS' - up cut only.

(See drawing following this text).

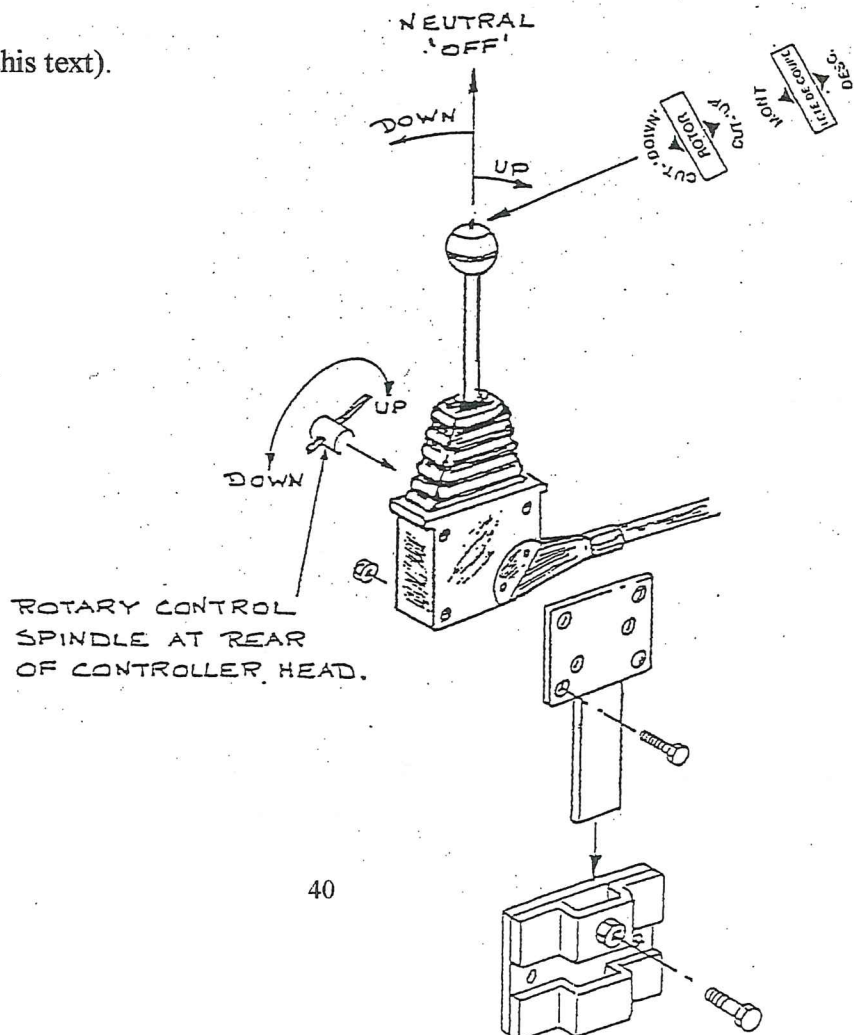

## HYDRAULIC CONTROLS - CUTTING POSITION

The cutting head must at all times be lowered gently into cut position. Never drop head into hedge at speed.

When cutting at ground level (grass etc.) the head must be lowered gently to give a slight contact pressure of roller to ground.

**IMPORTANT:** Ensure rotor and roller do not get involved in high obstacle forces such as rocks, stones, stumps etc. Keep rotor away and free from wire, as to entangle wire into rotor is very dangerous and very costly.

Should large obstacles be encountered or wire caught in rotor **STOP IMMEDIATELY**. Reset or clear before starting.

Normal obstacles and level variations should be overcome by operator by slowing 'forward motion' and raising/lowering the booms of trimmers to suit.

## CUTTING HEAD

The cutting head rotor has been balanced prior to fitting, this will ensure a vibration free cutting unit.

Should the rotor become blocked for any reason, hit an obstacle, loose a blade or blades, the rotor may be put into a state of unbalance. This will result in vibration from the rotor being transmitted through the head.

Should this happen **STOP IMMEDIATELY**, as to continue could have serious consequences.

Once stopped clean rotor and check for loss of blades and bolts, replace as required.

As a result of hitting solid objects with serious force the rotor can be bent, this will obviously cause vibrations. In such cases the only answer will be to get rotor repaired/rebalanced or replaced.

# TRANSPORTING

## STANDARD STRAIGHT BOOM MACHINE

- (1) Turn cutting head to vertical position with flails away from tractor.

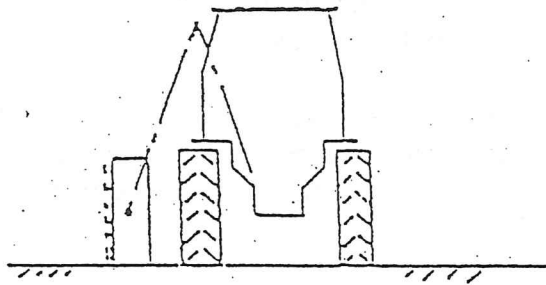

- (2) Swing machine rearwards by powering breakback ram to 'open' position.
- (3) Fold 'in' second/outer boom with cutting head, until boom main tube contacts rubber buffer fixed to first boom.
- (4) The cutting head should now be positioned behind and slightly inside tractor rear tyre.

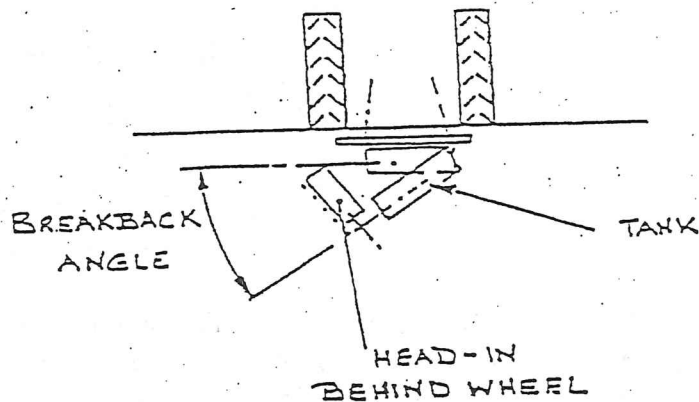

- (5) Unit now ready for transport.



## TRANSPORTING CONT:-

### FORWARD BOOM MACHINES

1. Ensure main breakback ram (Tank to sub frame) is opened to full extent.
2. The smaller breakback at point where (Forward boom meets outer boom) should be extended to its full extent also.
3. With both of these rams opened to their maximum, the machine will be folded rearwards to its transport position. Only the up and down movement of booms in relation to tank will give the optimum position for transport be found to suit individual tractors.
4. Booms should be positioned by operating boom rams to give a cutting head storage position which should be behind nearside rear tractor wheel (on L/H cut machine) and will give approx. 600mm head lower face to floor.

NOTE:- HEAD STORED VERTICALLY (Flails pointing away from tractor.)

(See Drawing Below)

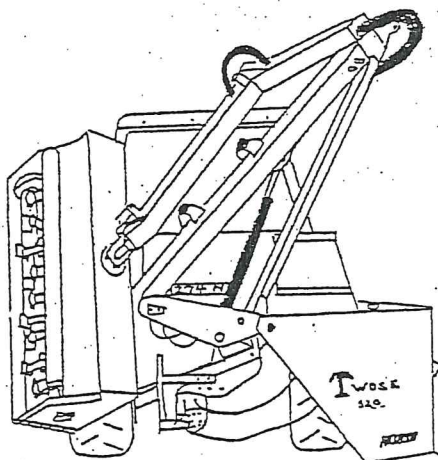

5. To obtain transport position - The main boom will be automatically folded over top of hydraulic oil tank and the outer boom will fold down to meet and rest upon buffer position (On bottom end of main boom). This is important and booms must always fold so as outer boom is in contact with buffer, for transport.

**NEVER TRANSPORT MACHINE WITH BOOMS 'OPEN' AND NOT IN CONTACT WITH EACH OTHER.**



## FLAIL HEAD

Keep the cutting blades VERY SHARP: this should be inspected daily. Bolts and nuts holding flails to rotor should be checked frequently and kept **tight**. Missing or broken flails should be replaced immediately, as the imbalance will rapidly harm bearings and structure. When a flail is renewed its opposing pair should be renewed also to maintain balance.

Check vee belt tension on cutter head daily: a load of 5 Kgs (10 lbs) should give a deflection of 9mm at these pulley centres. Access to the belts is by removing the guard panel on the side of the drive end. Tension is adjusted by first slackening the bolts mounting the motor (nuts are held from turning on the inside). The nuts on the threaded adjuster can now be turned to give the required tension and then re-tightened and the motor mounting bolts then tightened also.

## TO ADJUST ROLLER HEIGHT

The flail head cutting height control roller has various height setting options.

See diagram below:- showing four height settings, ranging from lowest cut through to highest cut.

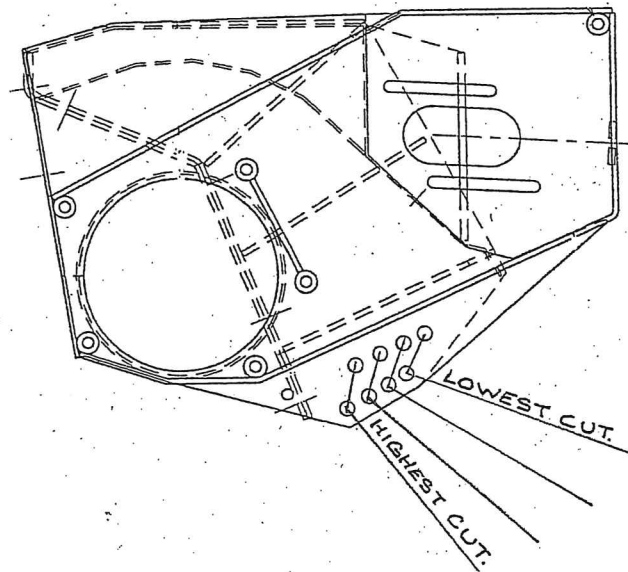

To alter roller position the pair of end brackets and relative securing bolts will need to be positioned at either of the four position height options offered.

NOTE:- Roller generally only required when bank/verge mowing and not hedgetrimming.

## HYDRAULIC OIL

### IMPORTANT

The hydraulic system will have been 'run-up' and checked at factory prior to machine despatch, where 'TEXACO RANDO 46' hydraulic oil is used - and is recommended for the machine.

### DANGER IMPORTANT

The hydraulic tank will have oil in it when delivered.

NOTE:- Oil tank capacity is (43 Gallon) 195 litres

### DANGER IMPORTANT

User must ensure hydraulic tank is full of 'RANDO 46' hydraulic oil (or equivalent) before attempting to start machine from new.

NOTE: The Tank top filter/breather is equipped with a strainer as standard, to ensure all oil is strained when being put into tank. For this reason the strainer basket - should never be removed and all hydraulic oil filling is to be done through the strainer.

### DANGER IMPORTANT

It is advisable NEVER to mix hydraulic oils, but if another suppliers oil is to be used a suitably compatible oil must be chosen (Check with oil supplier).

### DANGER IMPORTANT

**OIL FILTER MUST BE CHANGED AT 50 HOURS INITIALLY AND EVERY 250 HOURS THEREAFTER.**

### HYDRAULIC PUMP - GEARBOX

The standard hydraulic gearbox will be fitted with S.A.E E.P 90 oil and this grade must be ensured when topping up. "Check oil level every 500 hours." NOTE - Gearbox capacity is 0.5 litres.

For the Hi-power gearbox (Hi-ton) universal oil should be used and this grade must be ensured when topping up. "check oil level every 500 hours" - NOTE - Gearbox capacity is 0.5 litres.

## ROUTINE MAINTENANCE AND LAYING UP

### DAILY

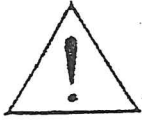

DANGER  
WARNING

Check oil level in main system oil tank



DANGER  
WARNING

Grease pivot points regularly



DANGER  
WARNING

Keep the cutting blades **VERY SHARP** -  
daily inspection is required here.

### WEEKLY



IMPORTANT  
DANGER  
WARNING

Check all hydraulic fittings and hoses



DANGER  
WARNING

Check vee belt tension on cutter head  
drive

### LAYING-UP

DANGER

Clean the machine and note any damage or repairs needed.  
Arrange for spares and repairs as required. Prepare for next  
season.



DANGER  
WARNING

Fully lubricate the machine totally



DANGER  
WARNING

Store machine in dry - undercover  
conditions.



DANGER  
WARNING

Check vee belt tension on cutter  
head drive.

## OBSERVE THE FOLLOWING HEDGE CUTTING OPERATIONS.

### WARNING

P.T.O speed to be 450 RPM. Minimum/540 maximum.

### DANGER

### WARNING

### VERY IMPORTANT

When cutting (in whatever position selected) it is that cutting head be kept as close to tractor as conditions and cutting position permits. This is to ensure maximum stability of unit.

### DANGER

### WARNING

Never operate rotor - with cutter flails directly towards operator, i.e underside of head - cutting face towards operator.

### DANGER

### WARNING

Rotor can be set to cut upwards - at front or to cut downwards - at front. The upward cut is the generally accepted norm - and will cope with grass/verge work as well as normal periodic hedgetrimming of up to approximately 2 years growth. Only when cutting large growth does the downward cut on rotor need to be used.

### WARNING

'DOWN CUTTING' is "NOT RECOMMENDED" and must only be selected for short periods only.

### DANGER

### WARNING

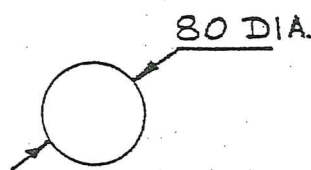

SOFTWOOD

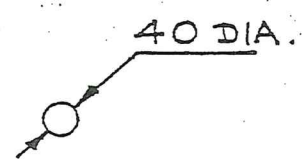

HARDWOOD

Cutting thickness limitation.

### DANGER

### WARNING

To use the rotor - set to cut downwards (at front) the front cowling of head will need to be removed.



**DANGER**  
**WARNING**

**Downward Cutting:-** For cutting larger material only.  
Gives poor finish.  
Higher Power requirements.  
Greater machine wear.

For the above reasons and as stated earlier in this manual DOWNWARD CUTTING IS NOT RECOMMENDED

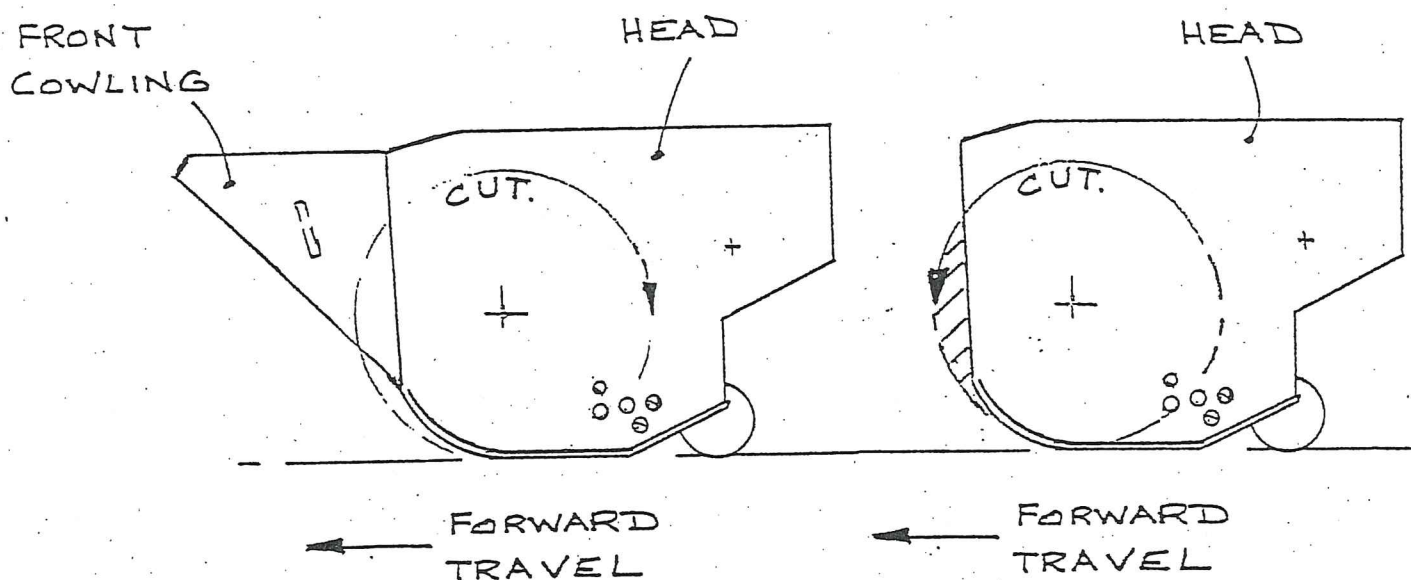

HEAD WITH FRONT COWLING  
IN PLACE - CUT UPWARDS  
AS INDICATED BY ARROW.  
(FOR GENERAL HEDGE-  
TRIMMING AND VERGE WORK)

HEAD WITH FRONT COWLING  
REMOVED, - CUT DOWNWARDS  
AS INDICATED BY ARROW.  
(FOR HEAVY CUTTING ONLY)

DANGER:-

NEVER CUT UPWARDS (AT FRONT) WITH HEAD FRONT COWLING REMOVED.

WARNING

Always use "UP-CUT" mode if possible.  
- Down cutting is (NOT recommended) and should only be considered in very difficult situations, and even then - always keep duration period as brief as possible, before returning to the 'UP-CUT' option.

## HANDLING & TRANSPORTATION OF MACHINERY

The drawing shown below indicates safe lifting points for the three models of Trimmer.

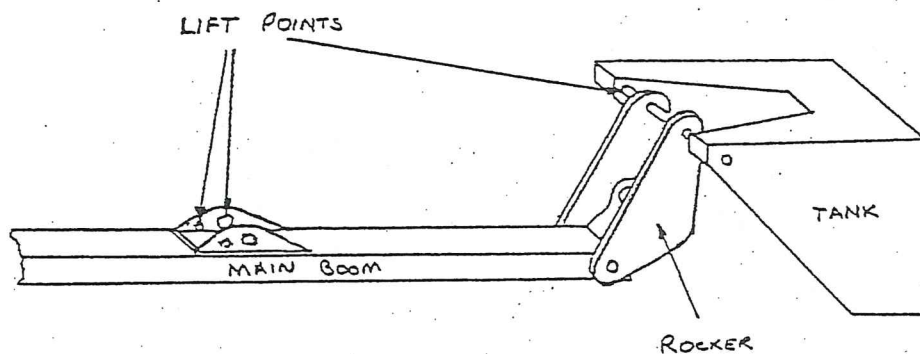

### 460/520/580 - Lift Points

The unladen weight of each Trimmer is given in the specification sheet of this book.

A form of lifting gear is required in order to move or handle this machinery safely. The lifting gear can be attached using a chain, rope or strap of sufficient strength, to the positions shown above.

Once the machinery has been moved, ensure that it comes to rest in a safe position. Supports or stay bars may be necessary to ensure stability of the machinery. Make sure the supports/stay bars are used whenever the machinery is transported.

SHOWN IN FLOAT POSITION ie  
LIFT GLAND TO TANK  
LIFT BASE TO ACCUMULATOR

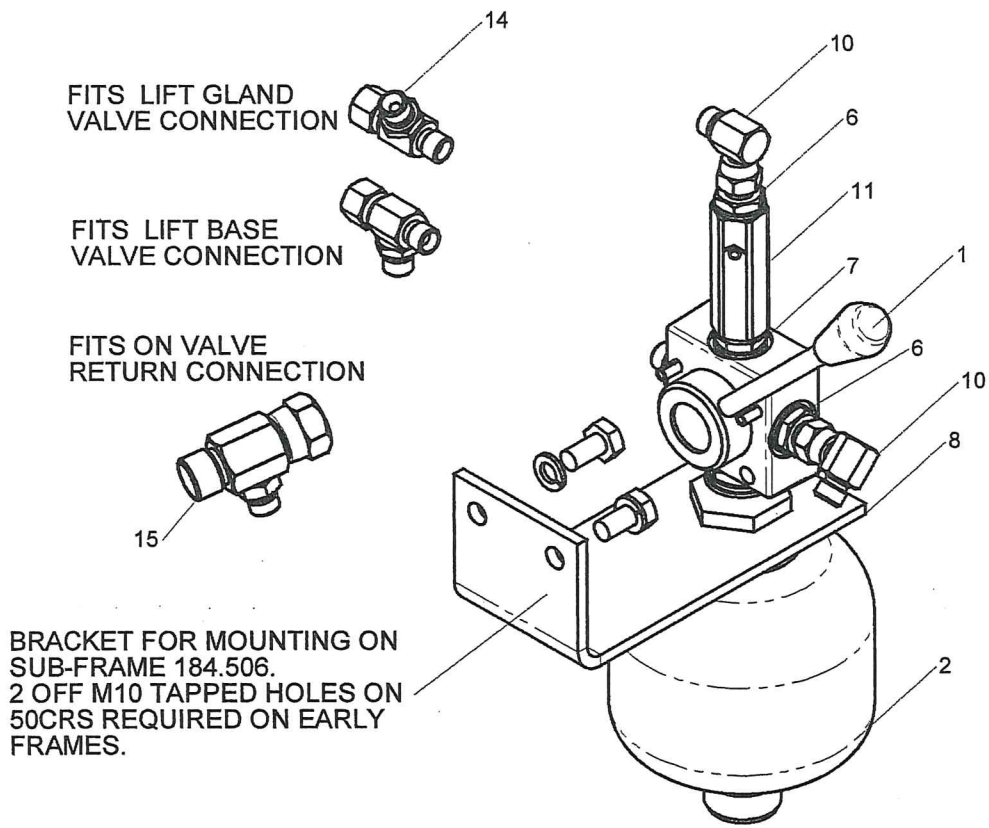

SHOWN VIEWED FROM TRACTOR SIDE  
FITTING TO A LH MACHINE.

Grass flailing can be a slow and tedious task requiring a high degree of operator concentration especially when working on a rough or undulating ground. The Float Kit will allow the task to be performed with greater ease.

### Putting into Lift Float

With the head down on the ground, the valve lever is turned clockwise. The 1<sup>st</sup> ram is now connected to the accumulator. Pressure should then be added to the accumulator via the 1<sup>st</sup> ram control to take approx. 50% of the flail head weight. This is important as with too little weight on the roller the flail head will tend to remain in the air after riding over a bump and leave uncut grass. With too much weight on the roller, the float will be inoperative; the ground will be scalped in places with increased flail wear etc.

It should be noted that the 1<sup>st</sup> ram control may feel spongy. For example when the 1<sup>st</sup> ram control lever is released the ram may continue to move for a short time.

### Putting out of Lift Float

With the head down on the ground, the valve lever is turned anti-clockwise.

ITEM NO.	QTY.	PART NO.	DESCRIPTION
1	1	T8200	VALVE 4 PORT 2 POS 3/8BSP
2	1	41451.02	ACCUMULATOR - 0.7LT (30 BAR)
3	6	8650103	BONDED SEAL 3/8"BSP
4	1	8650104	BONDED SEAL 1/2"BSP"
5	1	6000112	ADAPTOR 3/8x1/2"BSP MM
6	3	8581115	ADAPTOR 1/4x3/8"BSP MM
7	1	6000113	ADAPTOR 3/8"BSP MM
8	1	184.683	BRK ACCUMULATOR
9	1	8126035	NUT
10	2	8581190	ADAP ELBOW 90 1/4"BSP MF
11	1	T6986	CHECK VALVE 3/8"BSP
12	2	9313045	SETSCREW M10x20
13	2	9100205	SPRING WASHER M10
14	2	8581254	ADAPTOR TEE 1/4"BSP MFM
15	1	04.056.25	ADAPTOR TEE 1/2BSPMF+1/4M
16	2	10.002.21	1/4"BSP FS/F90 1100
17	1	10.002.23	1/4"BSP FS/F90 1300





## PARTS LIST

Always order Two genuine spares for your machine. They are correctly designed to give the best operational results.

When ordering spare parts, please specify:-

Type and Serial Number of machine  
Part number, description and quantity of spares  
required.

Always make sure that you have ordered a sufficient quantity to complete the job.

Always make sure that you have ordered the correct parts. In some instances (eg Hydraulic Rams) parts or assemblies are, in the course of time, modified due to introduction of new materials, or improved design.

Always state by what means you wish the goods to be sent. In the absence of specific instructions consignments will be sent by post or railways goods service, if it is not possible to deliver by our own transport.

Always State the number of our Invoice or Sales Slip, and the reason for return should it become necessary to return any items for exchange or credit.

## WARRANTY AND SPARE PARTS

all enquiries regarding these machines and orders for spare parts must be addressed to:-

TWOSE OF TIVERTON LIMITED  
BLUNDELLS ROAD  
TIVERTON  
DEVON  
EX16 4JT

TELEPHONE (01884) 253691  
FAX (01884) 255189

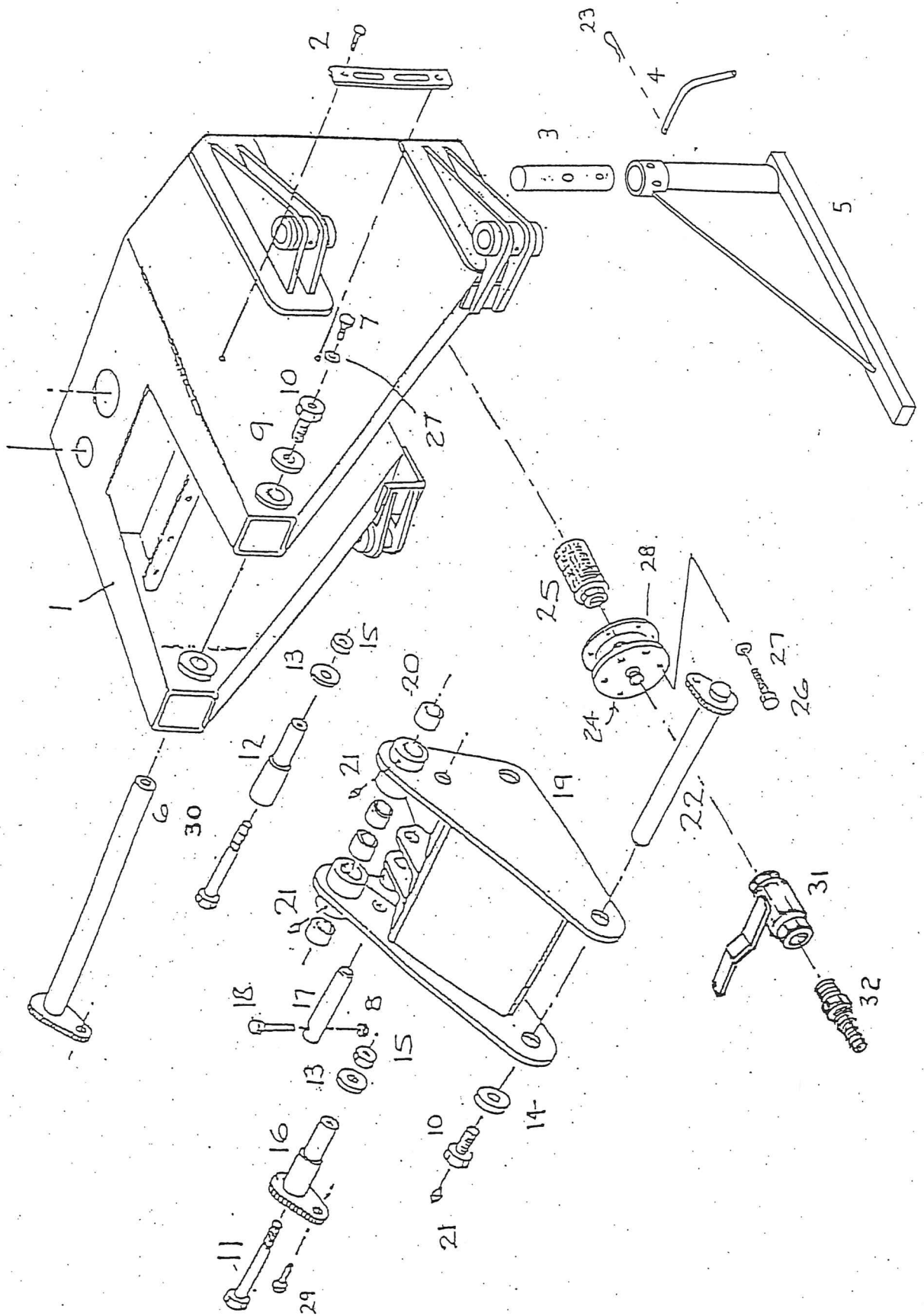

## TANK - ROCKER - PINS ETC

<u>ITEM</u>	<u>PART NO.</u>	<u>DESCRIPTION</u>	<u>QTY</u>
1	184.505	Tank Assembly	1
2	7804	Oil Level Gauge	1
3	184.511	Pin 40 Dia BDMS x 260	1
4	184.293	Pin 12 Dia BDMS x 152	1
5	184.510	Stand leg	1
6	184/438	Main Pivot Pin	1
7	2917	Setscrew M10 x 25	1
8	4421	Stiffnut M10 Nyloc	1
9	184.098	Washer (Special)	1
10	184.089	Setscrew (Special) M24 x 40 (Tapped)	2
11	4398	Bolt M12 x 240 (8.8)	1
12	184.609	Pin 'Ram Lower'	1
13	184.403	Washer 'Special' M12 (60 O.D)	2
14	184.064	Washer 'Special' M12	2
15	3082	Stiffnut M12 Nyloc	2
16	184.610	Pin 'Ram Upper' (460, 520)	1
17	184.238	Pin (2nd Ram Anchor)	1
18	3136	Bolt M10 x 60 (8.8)	1
19	184.422	Rocker Assembly	1
20	7488	Bush 4540 M	4
21	2923	Grease Nipple (M10)	3
22	184.065	Pin - First Boom	1
23	2435	Clip for stand leg	1
24	184.398	Filter & Tap Mounting Plate	1
25	3717	Strainer-Suction 1 1/2" BSP UC-SE-1324	1
26	2917	Setscrew M10 x 25	6
27	2728	Washer M10 Spring	7
28	1840402	Gasket	1
29	2710	Setscrew M10 x 30 (8.8)	1
30	3229	Bolt M12 x 150 (8.8)	1
31	7619	Tap (1 1/4" BSP)	1
32	7999	Hose Tail (1 1/4" BSP)	1

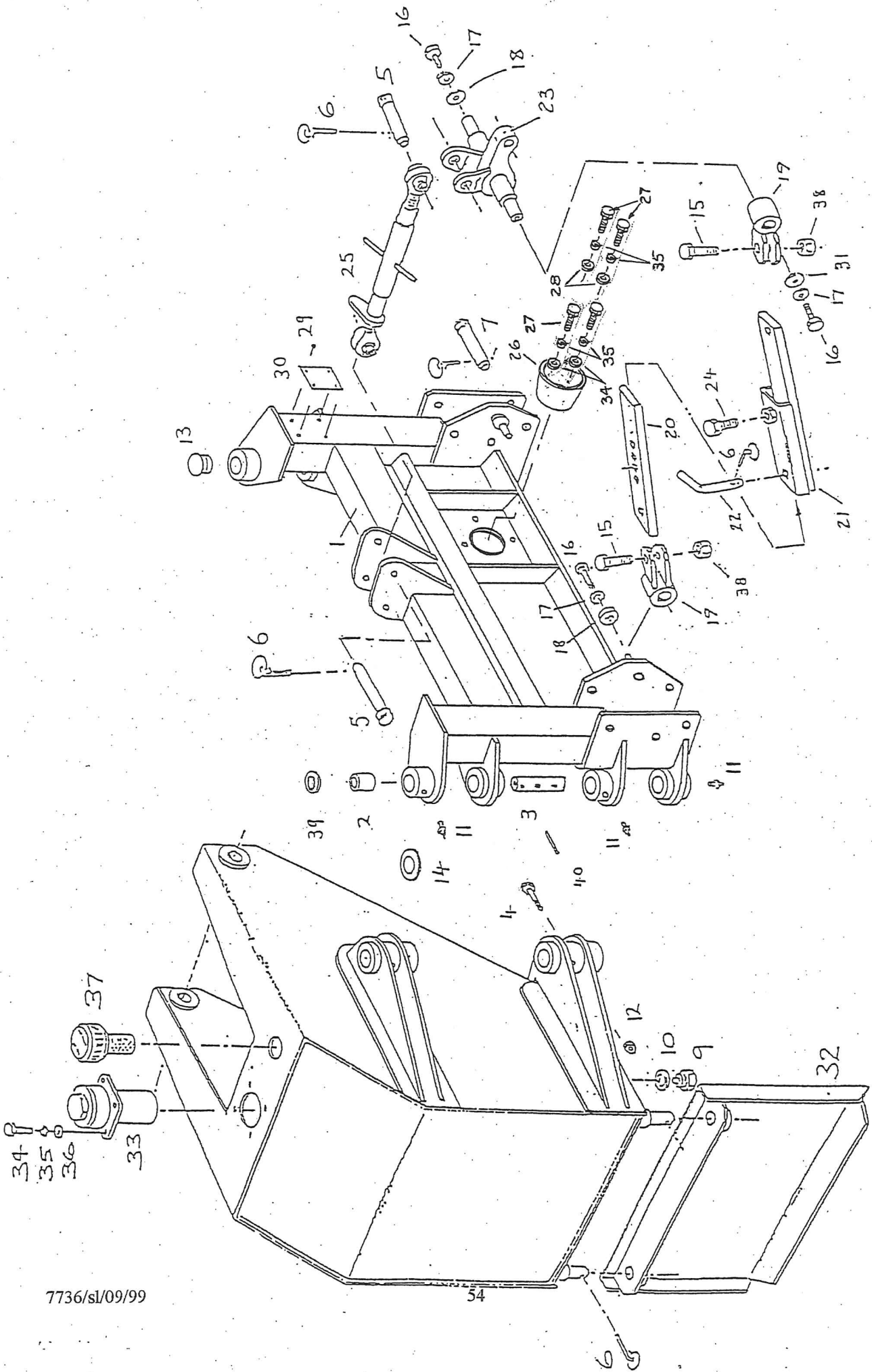

7736/sL/09/99

## SUB FRAME AND STABILIZERS

<u>ITEM</u>	<u>PART NO.</u>	<u>DESCRIPTION</u>	<u>QTY</u>
1	184.506	Sub Frame	1
2	6257G	Bush 4040m Bronze/steel	8
3	184.538	Pin	3
4	3191	Setscrew M8 X 75 (8.8)	2
5	2584	Pin (Linkage) 1"	2
6	0832	Spring pin assy. 7/16" Linch pin	10
7	7482	Pins (Linkage 1-1/8")	2
8	184.308	Spacer I.D (Lower Linkage)	2 (Not Ill.)
9	7753	Plug 1/2" B.S.P. Magnetic	1
10	0909	Seal 1.2" B.S.P	1
11	2923	Grease Nipple (M10)	6
12	3182	Stiffnut M8 Nyloc	2
13	7851	Bung 40 Dia	1
14	7872	Thrust Washer WC400K	1
15	2705	Bolt M20 x 75 (8.8)	4 *
16	2892	Setscrew M16 x 40	4
17	2730	Washer M16 Spring	4
18	184.436	Washer M16 Special	2
19	184.430	Anchor Bracket - Stabiliser	4
20	184.671	Inner Slide - Stabiliser	2
21	184.672	Box - Stabiliser	2
22	184.437	Pin - Stabilisers	2
23	184.435A	Top Link Coupler (Standard)	1
or	184.435B	Top Link Coupler (Narrow)	1
24	3904	Setscrew M20 x 45 (8.8)	2 *
25	7758	Top Link Assembly (Cat.2)	1
26	6385	P.T.O Guard	1
27	2950	Setscrew M12 x 30 (8.8)	4
28	2716	Washer M12 Form 'A'	2
29	0460	Screw St No 6 x 3/8" Type 'U'	4
30	6900	Plate (Serial No.)	1
31	185.096	Washer - Special	2
32	184.295	Plate - Stand - Tank End	1
33	7752	Filter Return - Cable Control M/C	1
	7752.1	Element 25 Micron (Cable Control M/C)	1
34	3192	Washer M12 form 'C'	2
35	2729	Washer M12 Spring	4



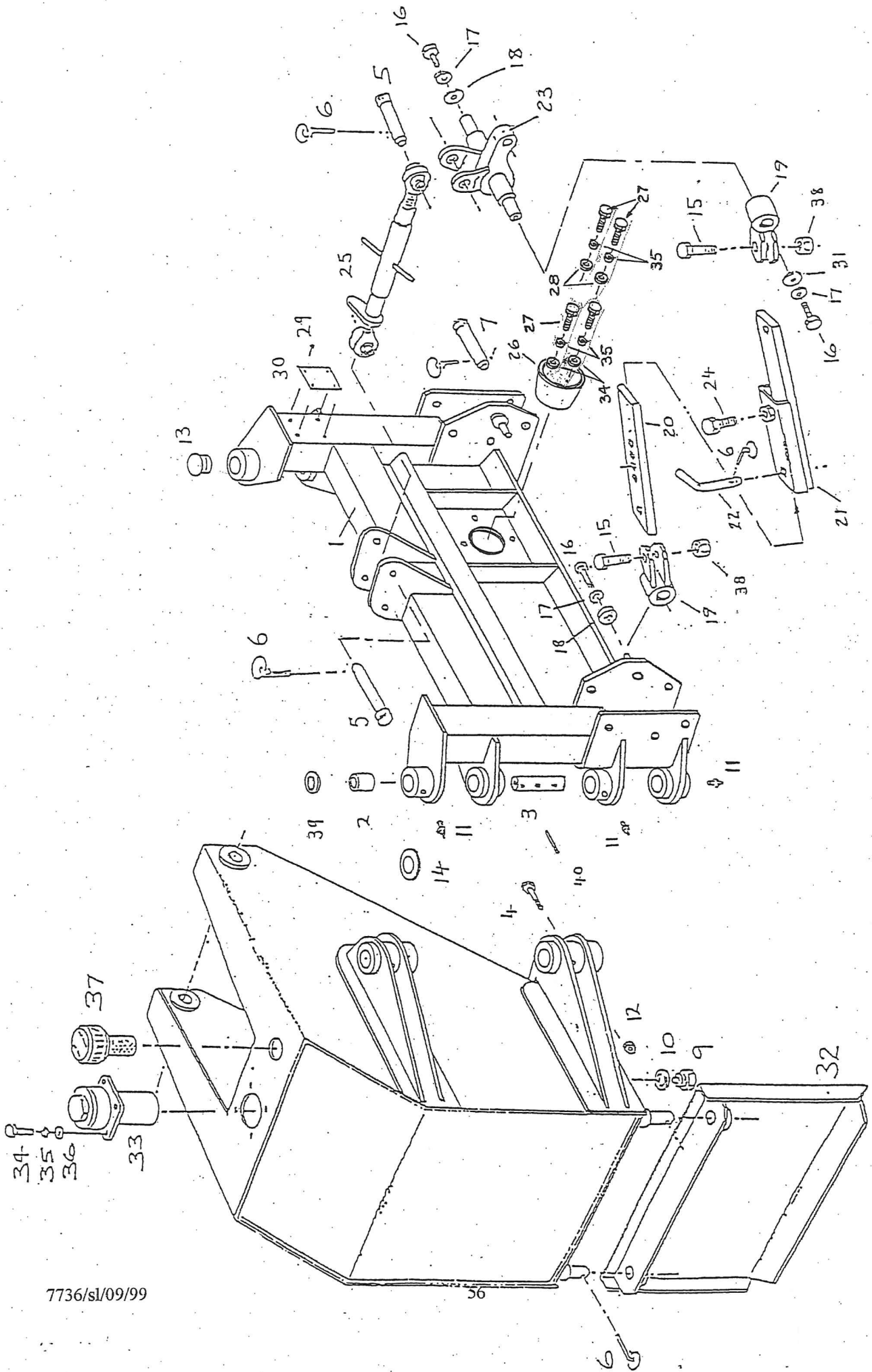



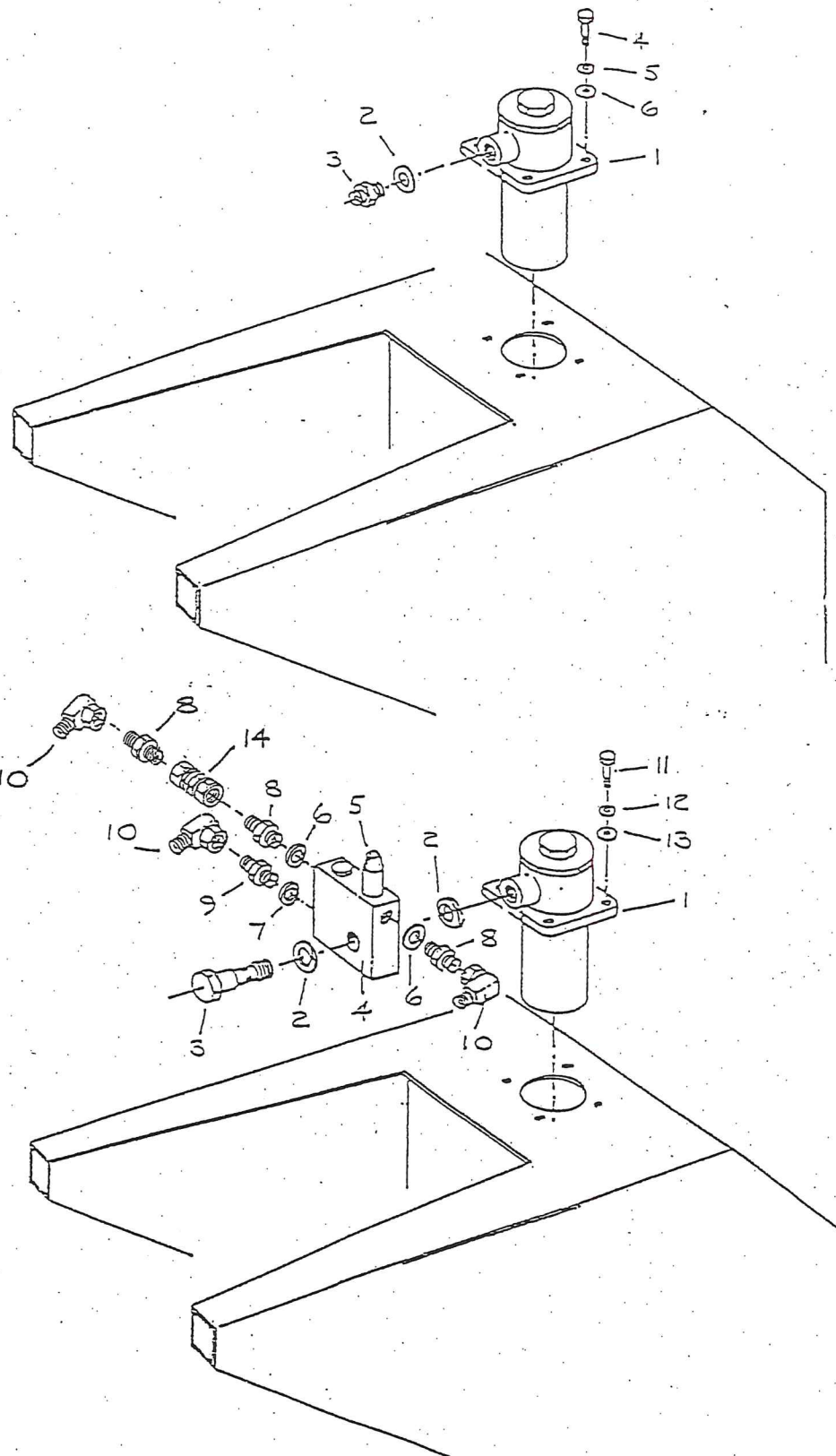

## RETURN FILTER AND CONNECTIONS

<u>ITEM</u>	<u>PART NO.</u>	<u>DESCRIPTION</u>	<u>QTY</u>
<u>Fully Independent Hydraulics -</u>			
For Cable Machines -			
1	7752 7752.1	Filter Return Element 25 micron	1
For Electric Machines -			
1	7761 7761.1	Filter Return Element 10 micron	1
2	3155	Seal 1 1/4" Dowty Bonded	1
3	5241	Adaptor 1 bsp x 1 1/4"	1
4	3110	Setscrew M8 * 30 (8.8)	4
5	3001	Washer M8 Spring	4
6	3111	Washer M8 Form A	4
<u>Tractor Independent Hydraulics -</u>			
1	7752 7752.1	Filter Return Element 25 micron	1
2	3155	Seal 1 1/4" Dowty Bonded	2
3	071.418	Banjo Bolt 1 1/4" BSP	1
4	3154	Valve Relief/Anti-Cav	1
5	7541	Relief Cart. 200 Bar	1
6	0934	Seal 3/4" Dowty Bonded	2
7	1934	Seal 1" Dowty Bonded	1
8	0935	Adaptor 3/4 BSP	3
9	1836	Adaptor 3/4 BSP x 1	1
10	3342	Adaptor 3/4 BSP m/f 91	3
11	3110	Setscrew M8 * 30 (8.8)	4
12	3001	Washer M8 Spring	4
13	3111	Washer M8 Form A	4
14	7830	Adaptor 3/4" BSP F/F loose	1

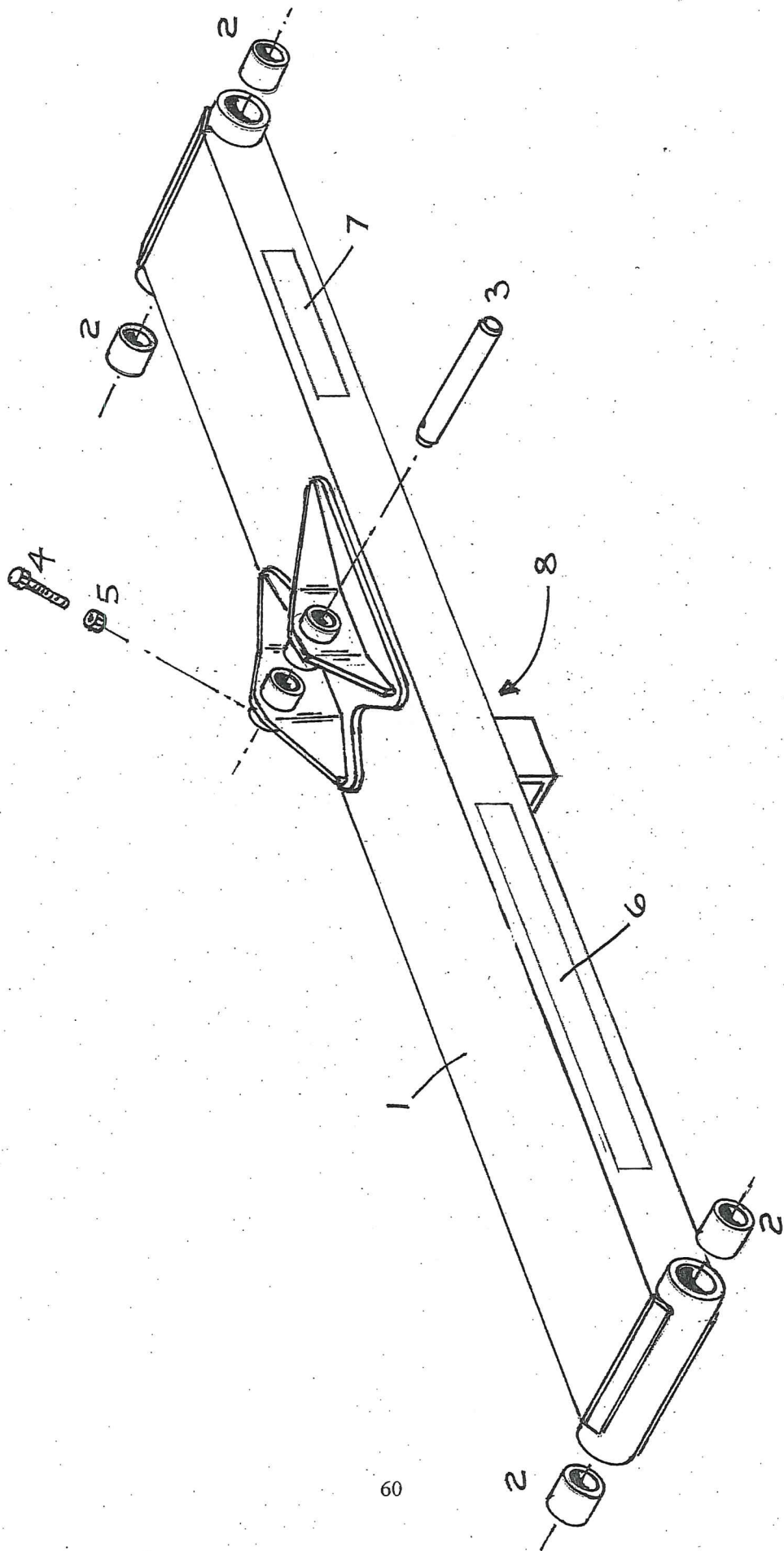



## FIRST BOOM

<u>ITEM</u>	<u>PART NO.</u>	<u>DESCRIPTION</u>	<u>QTY</u>
1	184.603A	First Boom 580	1
or	184.602	First Boom 520	1
or	184.601	First Boom 460	1
2	7488	Bush 4540M	4
3	184.604	Pin (for 2nd ram)	1
4	3262	Bolt M8 x 60 (8.8)	1
5	3182	Stiffnut M8 Nyloc	1
6	410184	Transfer “(<<<<<<<<<)”	2
7	410186	Transfer “Twose” (sm. black)	2
8	1840209	Transfer “Close Boom...”	1

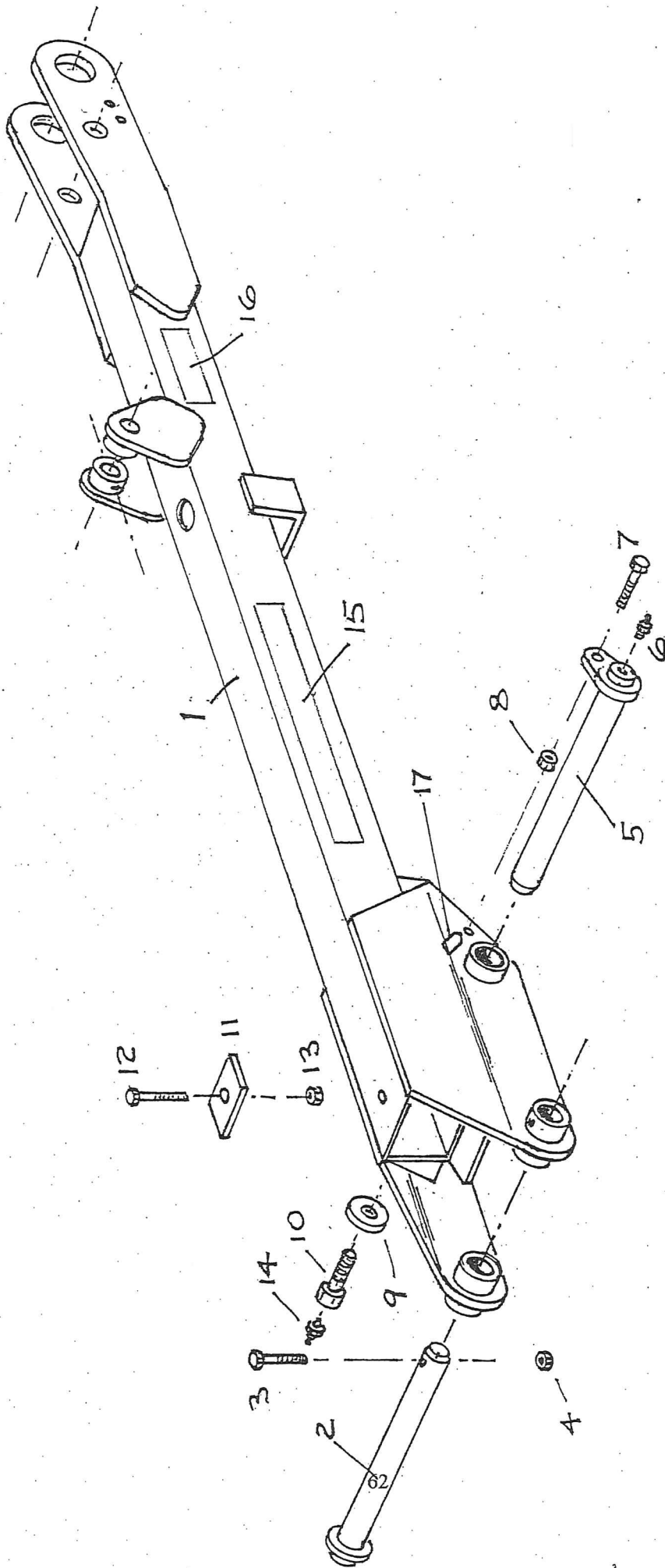

7736/sl/09/99



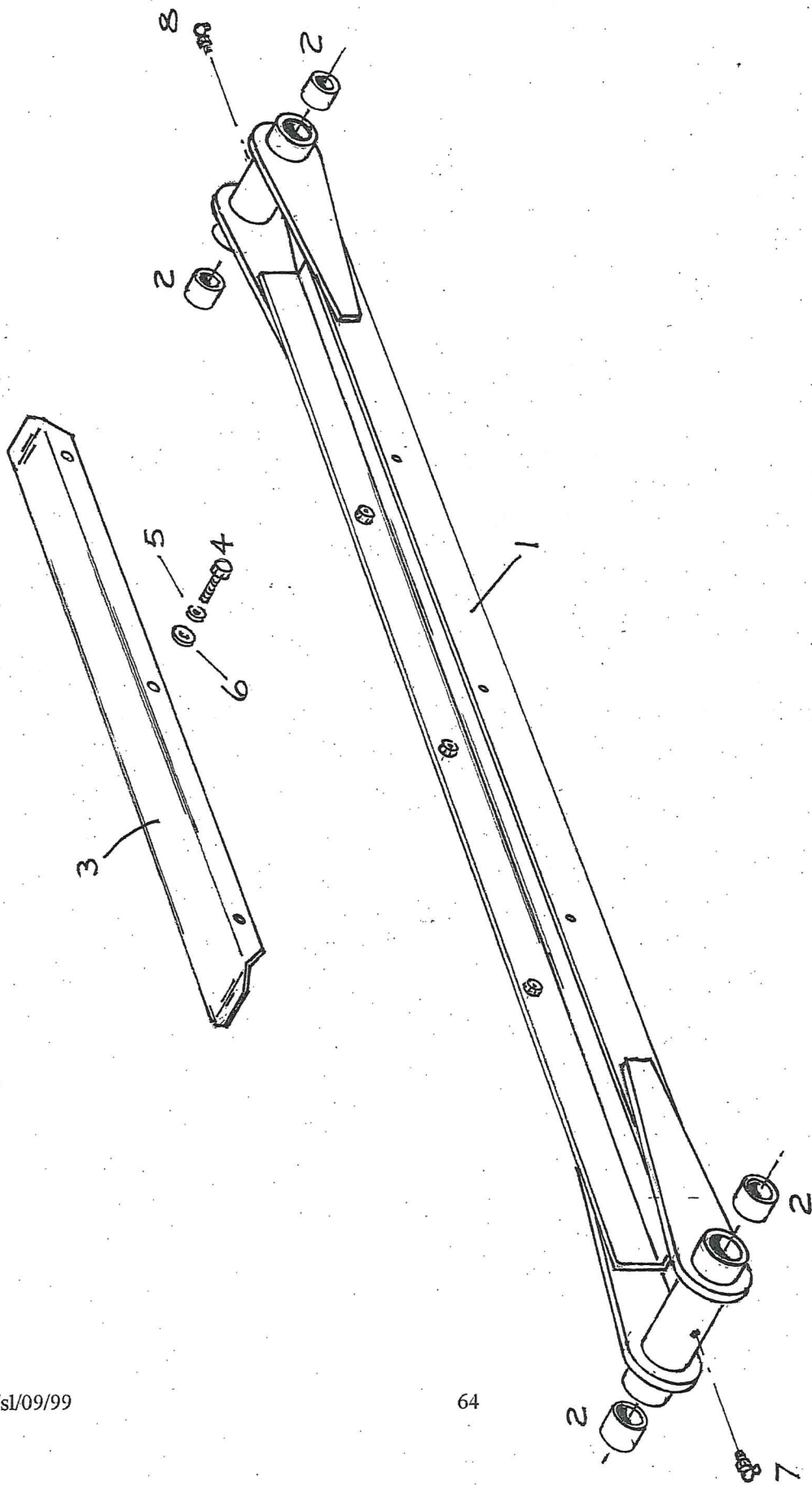

## TIE ARM

<u>ITEM</u>	<u>PART NO.</u>	<u>DESCRIPTION</u>	<u>QTY</u>
1	184.553	Tie Arm - 580	1
or	184.562	Tie Arm - 520	1
or	184.561	Tie Arm - 460	1
2	7488	Bush 4540M	4
3	184.554	Pipe guard - 580	1
or	184.563	Pipe guard - 520	1
or	184.563	Pipe guard - 460	1
4	3731	Setscrew M8 x 16 (8.8) for 184.563	6
or	3731	Setscrew M8 x 16 (8.8) for 184.554	8
5	3001	Washer M8 Spring for 184.563	6
or	3001	Washer M8 Spring for 184.554	8
6	3111	Washer M8 (Form 'A') for 184.563	6
or	3111	Washer M8 (Form 'A') for 184.554	8
7	2944	Grease Nipple 90°, M10 x 1.5	1
8	2944	Grease Nipple 90°, M10 x 1.5	1



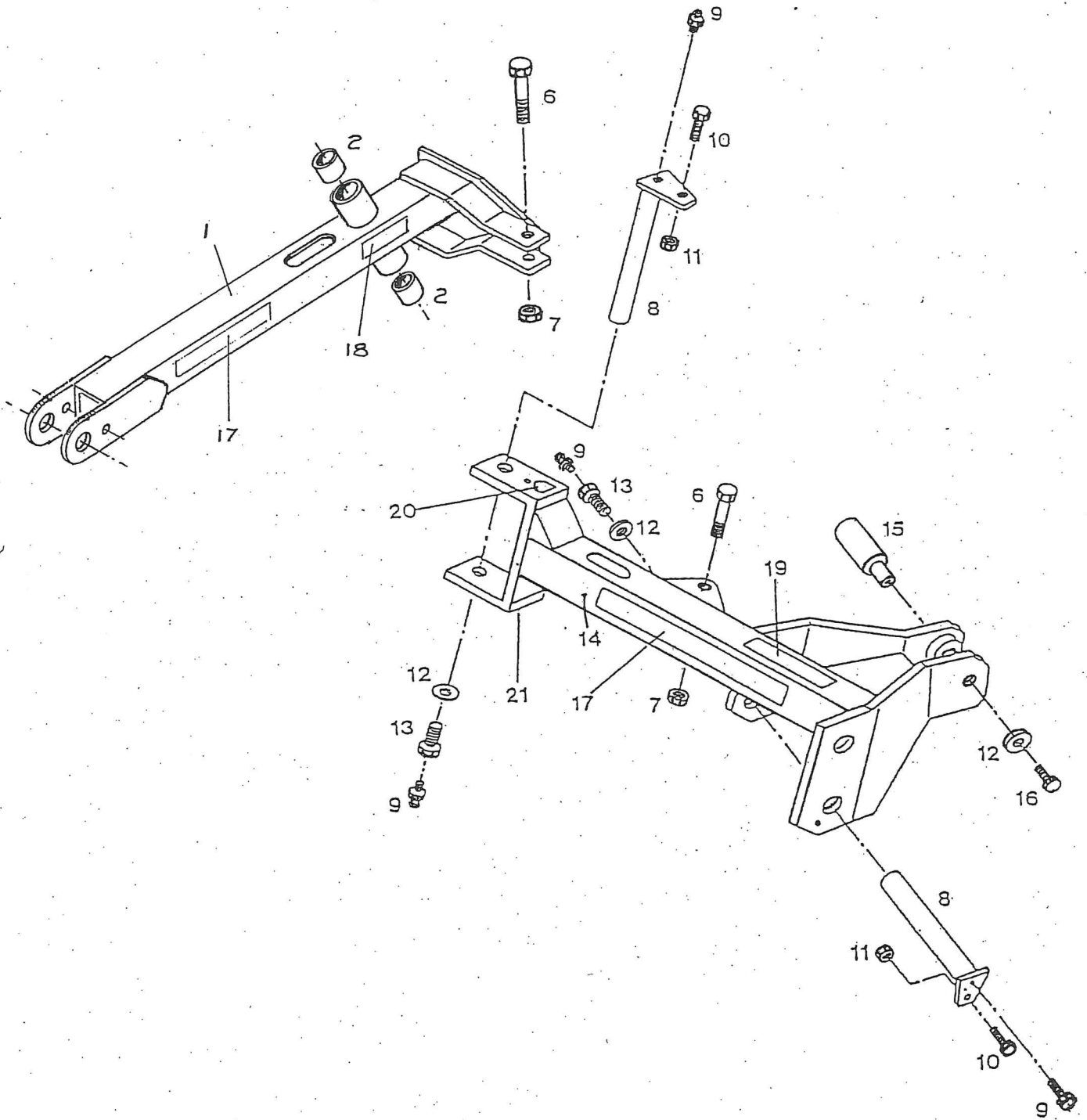

## FORWARD BOOM

<u>ITEM</u>	<u>PART NO.</u>	<u>DESCRIPTION</u>	<u>QTY</u>
1	184.359 A/L	Outer Boom (L/H) 520 Machine	1
OR	184.359 A/R	Outer Boom (R/H) 520 Machine	1
OR	184.359 B/L	Outer Boom (L/H) 460 Machine	1
OR	184.359 B/R	Outer Boom (R/H) 460 Machine	1
2	7488	Bush	2
3			
4			
5			
6	184.358	Pin	2
7	4776	Stiffnut M6 Nyloc	2
8	184.065	Pivot Pin	2
9	6956	Grease Nipple M10	4
10	2710	Setscrew M10 x 30	2
11	4421	Stiffnut M10 (nyloc)	2
12	184.064	Washer	3
13	184.089	Setscrew M24 x 40 Special	2
14	184.357L	Forward Boom L/H Machine	1
OR	184.357R	Forward Boom R/H Machine	1
15	184.298	Pin	1
16	7755	Bolt M12 x 200 (8.8)	1
17	410184	Transfer (Chevron)	3
18	410185	Transfer (Twose) large	2
19	410186	Transfer (Twose) Small	1
20	410201	Transfer (Grease)	3
*	1840283	Breakback Cylinder	1
21	6981	Bolt M6 x 50 (8.8)	2
22	184.360	Tie Arm (Galleried head only)	1
*	2892	Setscrew M16 x 40 (8.8) (For Tie Arm)	2
*	3747	Nut M16 Nyloc (For Tie Arm)	2
23	3082	Nut M12 Nyloc	1

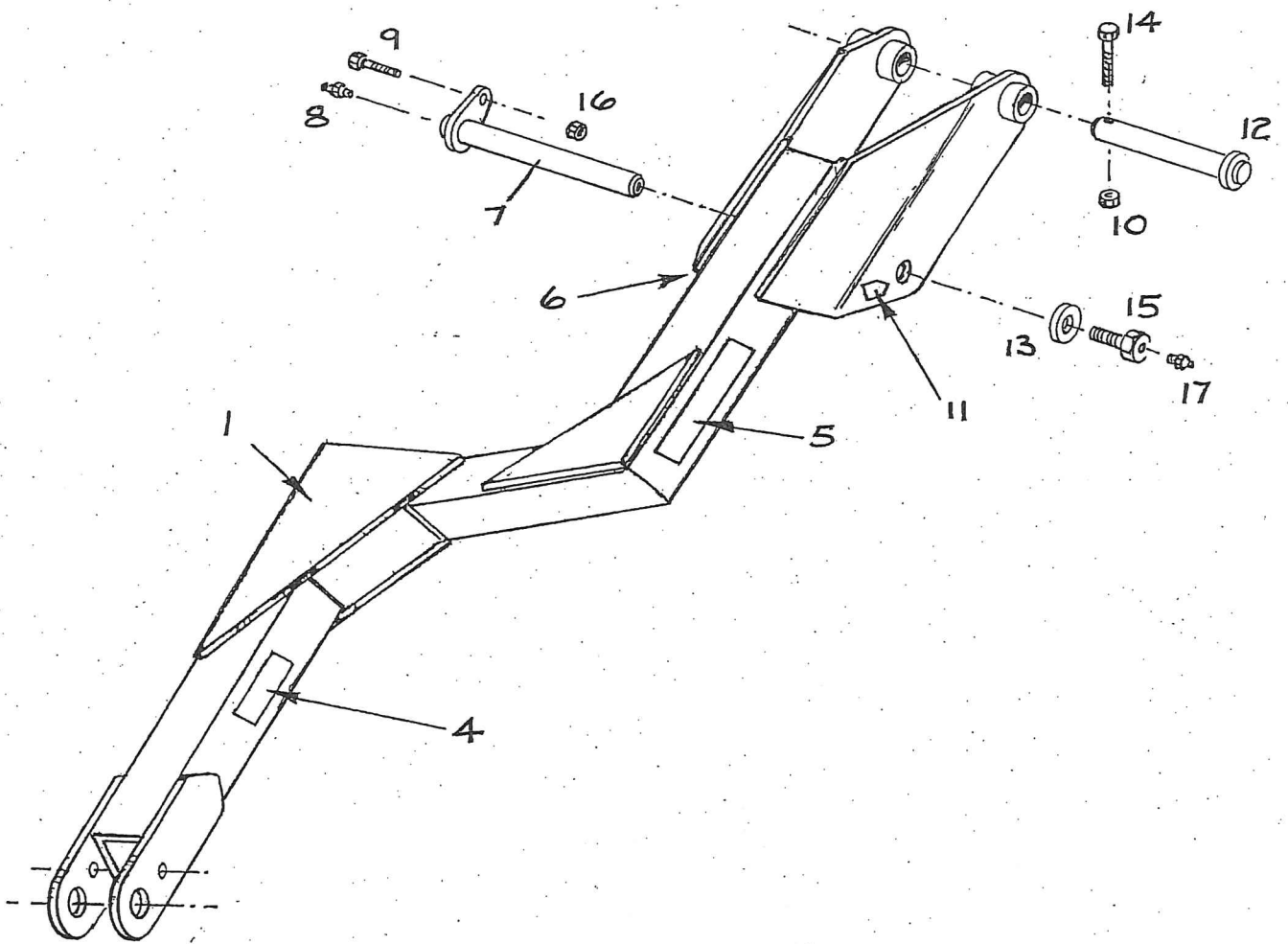

## SIMPLE FORWARD BOOM

<u>ITEM</u>	<u>PART NO.</u>	<u>DESCRIPTION</u>	<u>QTY</u>
1	184.412A/B/CL/R	Main Boom	1
2			
3			
4	410185	Transfer	1
5	410184	Transfer	1
6	410192	Transfer	1
7	184.065	Pin, 'First Boom'	1
8	2923	Grease Nipple (M10)	1
9	2698	Bolt M10 x 40 (8.8)	1
10	3182	Stiffnut M8 Nyloc	1
11	410201	Transfer "Grease Gun"	1
12	184.555	Pin 45 Dia EN8 x 325	1
13	184.098	Washer (60 O.D x 6)	1
14	3191	Setscrew M8 x 75 (8.8)	1
15	184.089	Setscrew M24 x 40 (Tapped)	1
16	4421	M10 Nyloc S/Nut	1
17	2923	Grease Nipple M10	1

NOTE:- Main Boom (Item 1) 184.412 -  
available as follows:-

184.412 A/L	= 520 H.T size and LH (English)
184.412 A/R	= 520 H.T size and RH (French)
184.412 B/L	= 460 H.T size and LH (English)
184.412 B/R	= 460 H.T size and RH (French)
184.412 C/L	= 580 H.T size and LH (English)

# TWOSE

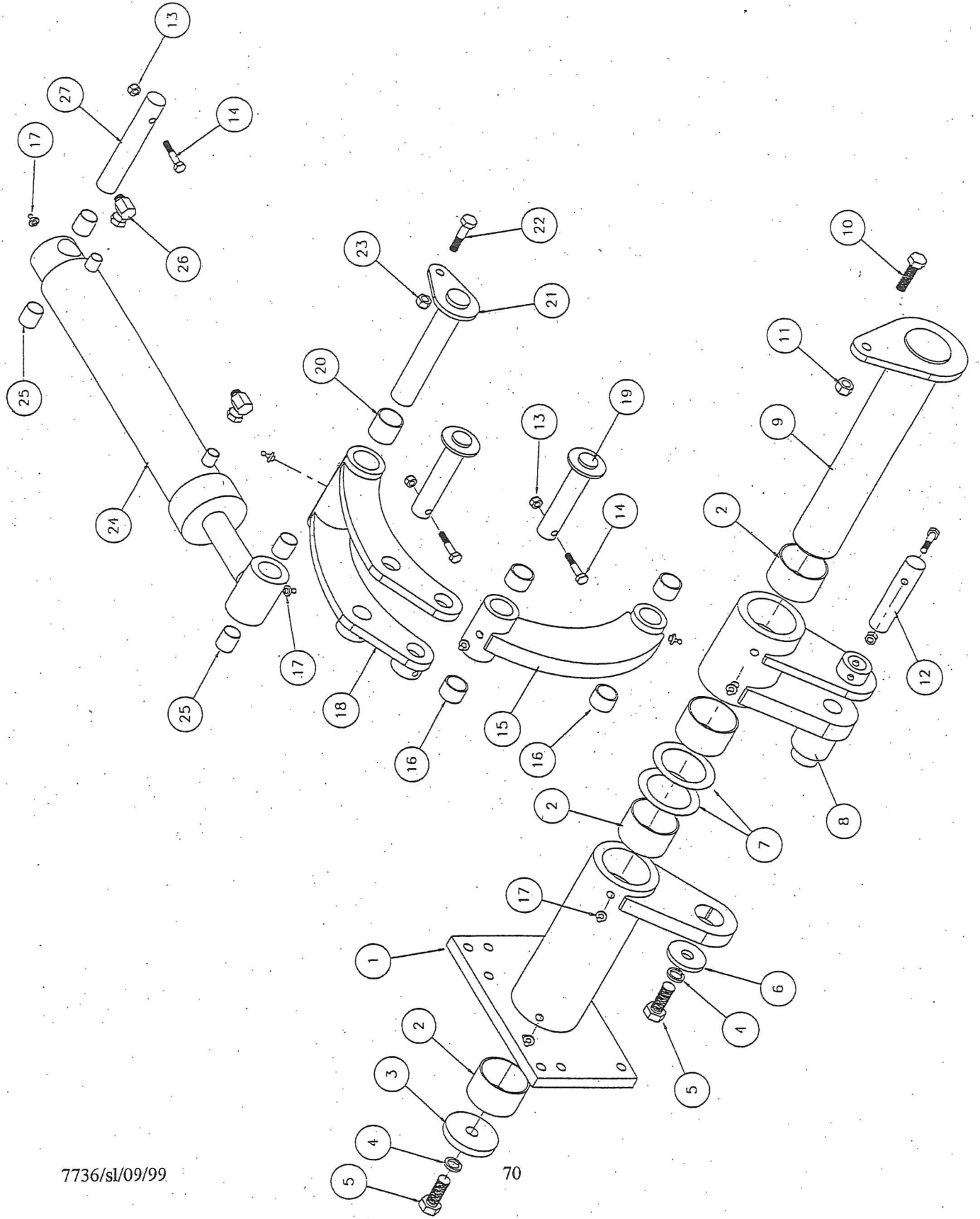

7736/sI/09/99



## HEAD PIVOT AND LINKAGE ASSEMBLY

<u>ITEM</u>	<u>PART NO.</u>	<u>DESCRIPTION</u>	<u>QTY</u>
1	184.494AL	Bracket Head Short LH Machine	1
or	184.494AR	Bracket Head Short RH Machine	1
2	6935	Bush	4
3	184-488-	Washer M16 Special	1
4	2730	Washer M16 Spring	2
5	2892	Setscrew M16 * 40 (8.8)	2
6	185-096-	Washer M16 Special	1
7	184.353	Thrust Washer	2
8	184.485	Bracket Head Angle	1
9	184.600A	Pin head pivot	1
or	184.600B	Pin head pivot long	1
10	5693	Setscrew M12 * 45 (8.8)	1
11	3082	Stiffnut M12 Nyloc	1
12	184.492B	Pin	1
13	3182	Stiffnut M8 Nyloc	4
14	3548	Bolt M8 * 50 (8.8)	4
15	184.491	Banana link Assy	1
16	7854	Bush Nylon	4
17	2923	Grease Nipple M10 x 1.5	8
18	184.486	Banana Double	1
19	184.492A	Pin assembly	2
20	5178	Bush Nylon	2
21	184.483	Pin Anchor for Banana	1
22	2698	Bolt M10 * 40 (8.8)	1
23	4421	Stiffnut M10 Nyloc	2
24	1840493	Ram Head Angle	1
25	8039	Bush 2520M	4
26	6948	Adaptor 1/4 bsp M-FLN 91	2
27	184.492C	Pin	1

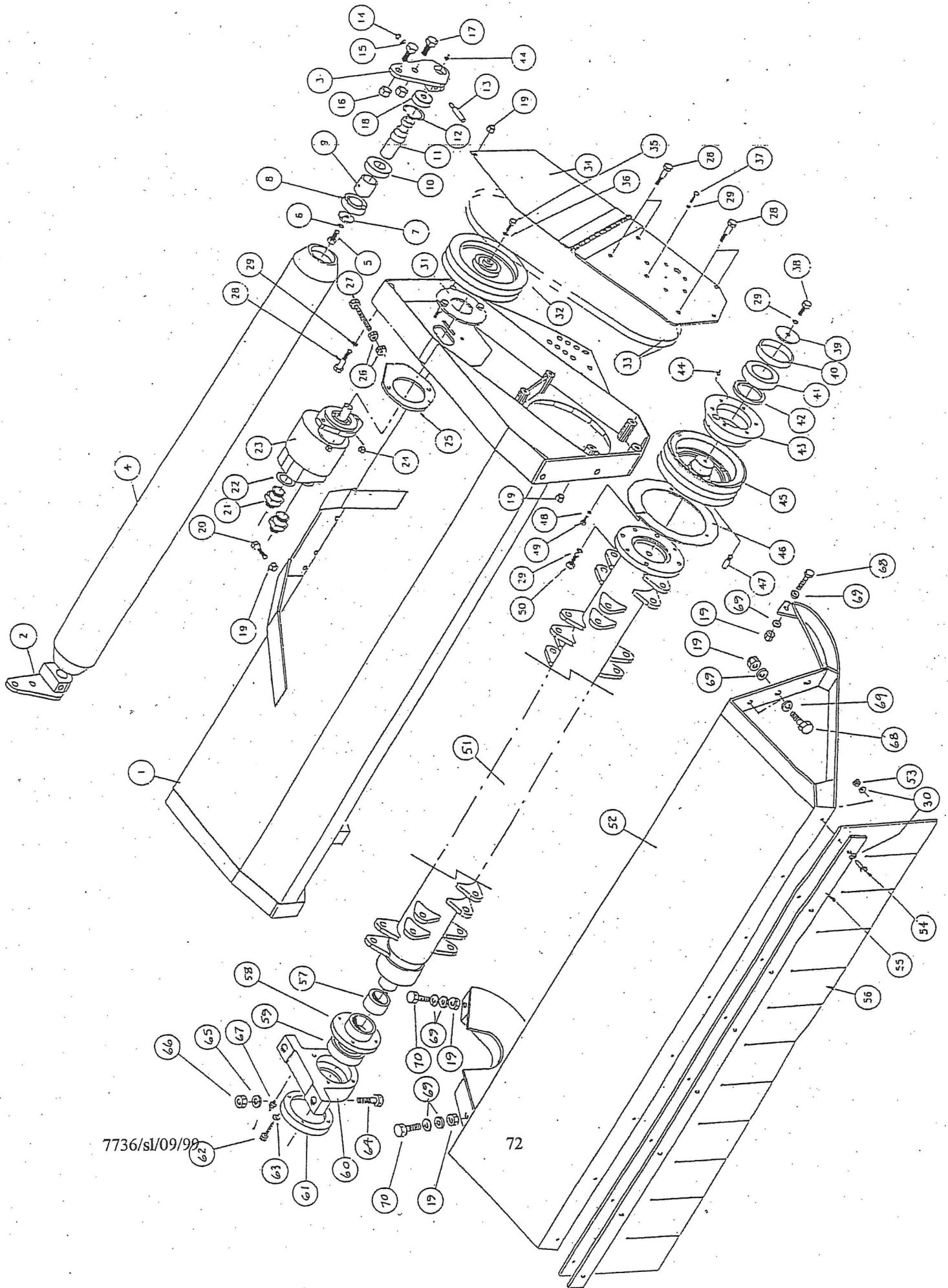

7736/s1/09/99

72

HEAD ASSEMBLY  
1.2M AND 1.52M

<u>ITEM</u>	<u>PART NO.</u>	<u>DESCRIPTION</u>	<u>QTY</u>
1	184.615A	Head 1.2m Weld Assy	1
or	184.615B	Head 1.52m Weld Assy	1
2	184.622R	Bracket Roller RH	1
3	184.622L	Bracket Roller LH	1
4	184.621A	Roller Assy 1.2m	1
or	184.621B	Roller Assy 1.52m	1
5	2711	Setscrew M12 x 20 (8.8)	2
6	2729	Washer M12 Spring	2
7	174.006	Washer M12 Special	2
8	8029	Bearing	2
9	184.589	Spacer	2
10	7898	Bearing	2
11	184.588	Shaft Stub Roller	2
12	8030	Circlip	2
13	1840591	Cotter Pin Special 1/4"	2
14	3182	Stiffnut M8 Nyloc	2
15	3111	Washer M8 Form A	2
16	3747	Stiffnut M16 Nyloc	4
17	2901	Setscrew M16 x 35 (8.8)	4
18	184.587	Spacer 30id	2
19	3082	Stiffnut M12 Nyloc	14
20	2733	Bolt M12 x 40 (8.8)	8
21	0935	Adapter 3/4 BSP	2
22	0934	Seal 3/4"	2
23	8027	Motor Gear Type for H/T	1
24	4421	Stiffnut M10 Nyloc	2
25	184.625	Motor plate assembly	1
26	2799	Fullnut M10	2
27	8172	Setscrew M10 x 80 (8.8)	1
28	2986	Bolt M12 X 80 (8.8)	6
29	2729	Washer M12 Spring	11
30	3111	Washer M8 Form 'A' for 1.2m Head	32
or	3111	Washer M8 Form 'A' for 1.52m Head	40
31	184.463	Motor Fixing Ring	1

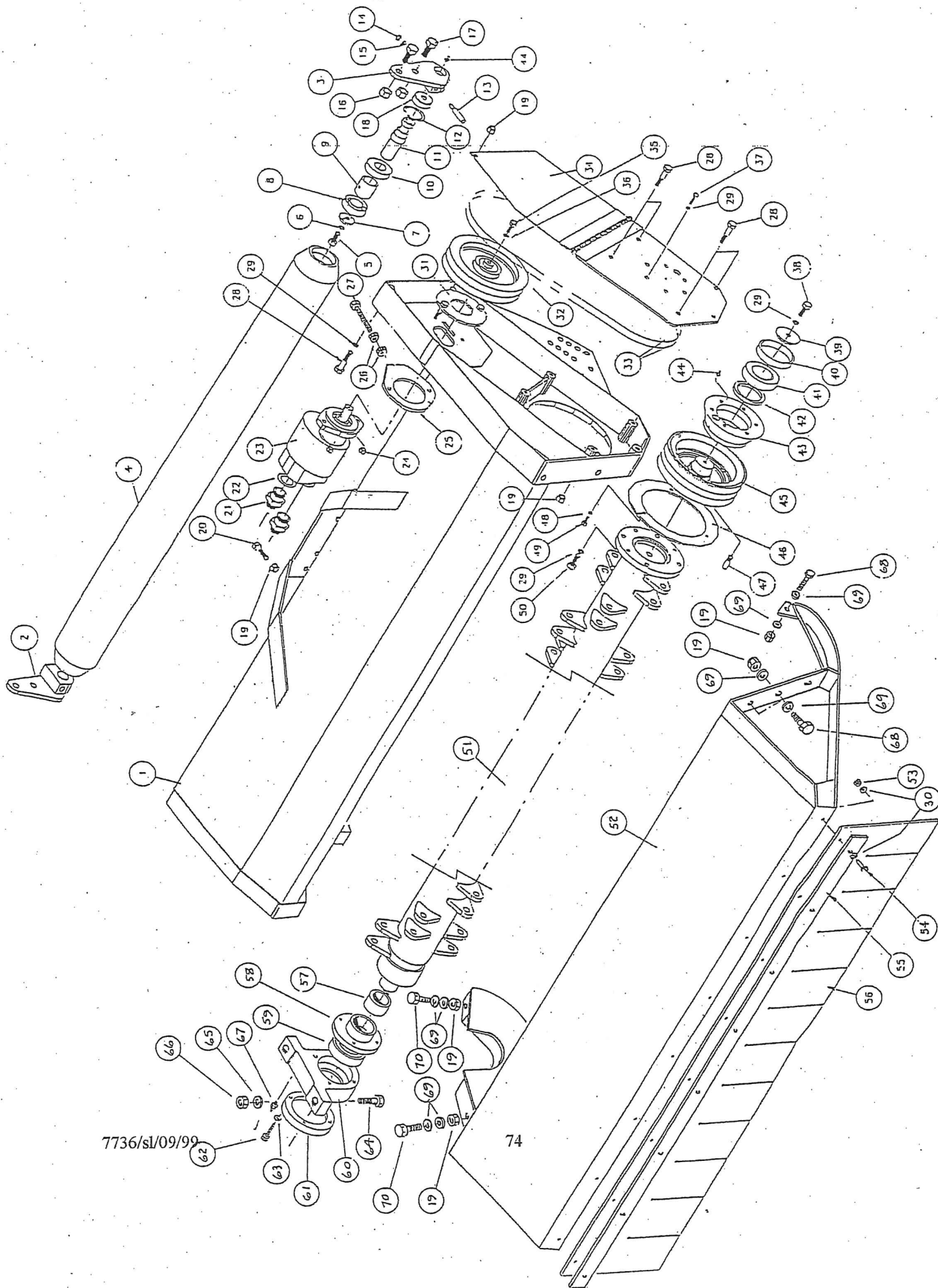

7736/sl/09/99



HEAD ASSEMBLY  
(1.2M AND 1.52M)  
CONTINUED

<u>ITEM</u>	<u>PART NO.</u>	<u>DESCRIPTION</u>	<u>QTY</u>
32	184.445	Pulley Motor 242 PCD	1
33	7692	Belt Vee	2
34	184.623	Drive Plate	1
35	7491	Bolt 3/8" UNF x 1"	1
36	0872	Washer Imp 3/8 Spring	1
37	2711	Setscrew M12 x 20 (8.8)	6
38	2950	Setscrew M12 x 30 (8.8)	4
39	184.461	Washer M12 Special	1
40	184.464	Spacer for Bearing	1
41	7840	Bearing	1
42	7790	Oil Seal	1
43	184.448	Bearing Housing	1
44	2923	G/Nipple M10 x 1.5	4
45	184.446	Pulley Rotor 200 PCD	1
46	184.636	Grass Ring	1
47	184.489	Dowel Pin	1
48	3001	Washer M8 Spring	3
49	2793	Setscrew M8 x 20 (8.8)	3
50	7855	Setscrew M12 x 35 FINE	4
51	184.618A	Rotor 1.2m Balanced - No flails, shackle type	1
or	184.618B	Rotor 1.52m Balanced - No flails, shackle type	1
or	184.619A	Rotor 1.2m Balanced - No flails, standard flails	1
or	184.619B	Rotor 1.52m Balanced - No flails, standard flails	1
or	184.620	Rotor 1.2m Rollicoupe Type	1
52	184.616A	Nose Weld Assy 1.2m	1
or	184.616B	Nose Weld Assy 1.52m	1
53	3182	Stiffnut M8 (for 1.2m head)	16
or	3182	Stiffnut M8 for (1.52m head)	20
54	2987	Setscrew M8 x 25 (8.8) (for 1.2m Head)	16
or	2987	Setscrew M8 x 25 (8.8) (for 1.52m Head)	20
55	184.617A	Clamp Strip for 1.2m Head	2
or	184.617B	Clamp Strip for 1.52m Head	2
56	1840476F	Curtain for 1.2m Head	2
or	1840581	Curtain for 1.52m Head	2



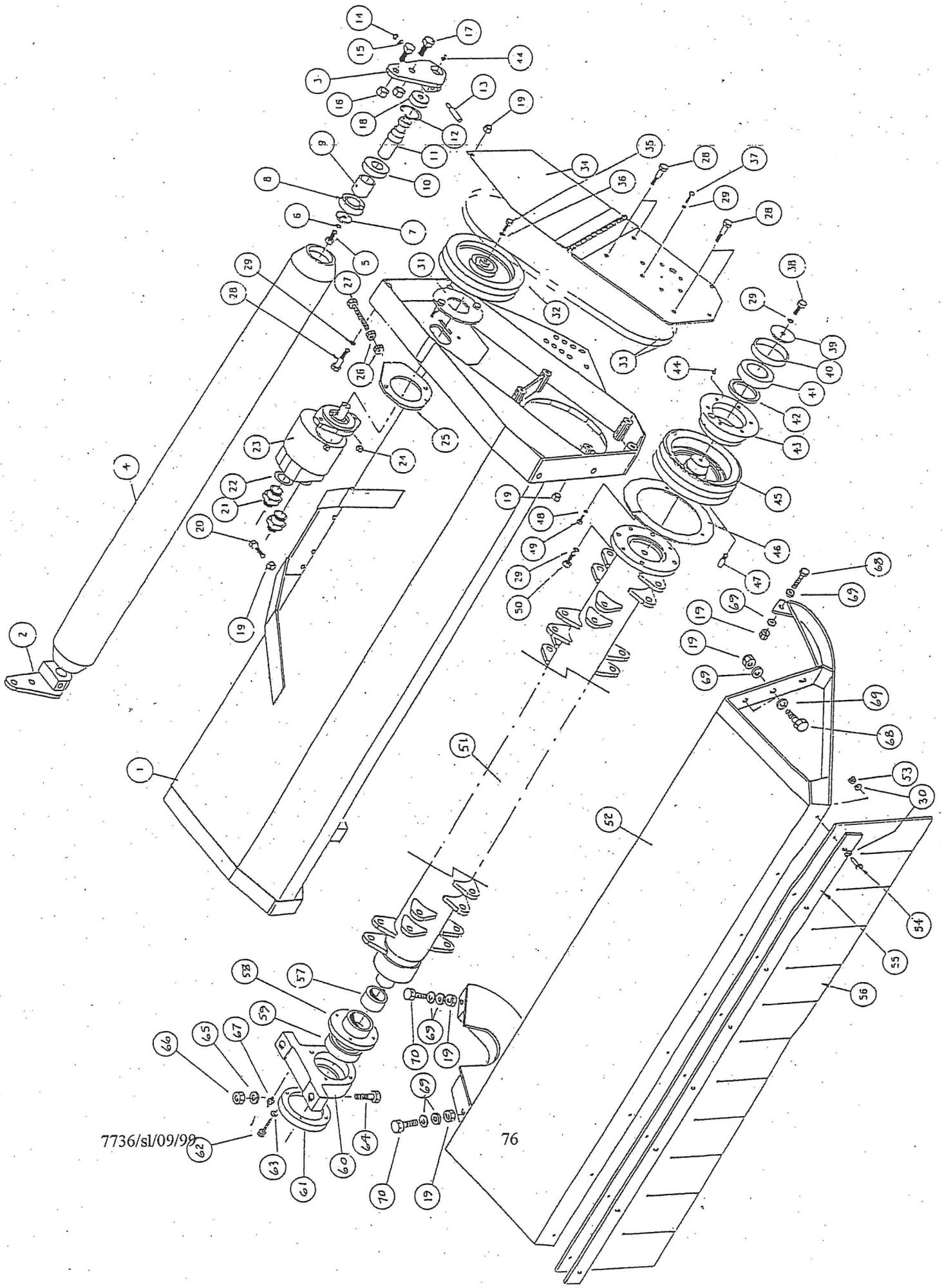

7736/sl/09/99

76

HEAD ASSEMBLY  
(1.2M AND 1.52M)  
CONTINUED

<u>ITEM</u>	<u>PART NO.</u>	<u>DESCRIPTION</u>	<u>QTY</u>
57	192.046	Spacer for bearing	1
58	192.026	Shield for Bearing	1
59	7941	Bearing	1
60	192.024	Housing for bearing	1
61	192.025	Cap for Bearing	1
62	6985	Setscrew-Socket M6 x 45 Cap	4
63	2731	Washer Spring M6	4
64	2878	Bolt M16 x 55 (8.8)	2
65	3747	Washer M16 Form 'A'	4
66	2867	Stiffnut M16	2
67	6956	Grease Nipple M6	1
68	2950	Setscrew M12 x 30 (8.8)	3
69	3192	Washer M12 Form 'C'	10
70	2962	Setscrew M12 x 35	2

## PARTS LIST FOR DS HEAD

Below are shown 3 types of rotor, along with the flail options available to fit each. Part numbers are given for rotors complete with flails and end bearings and also for the flails, spacers, nuts and bolts individually.

Note - though it is possible to supply rotors balanced without flails we do not recommend this.

### 184.618 Type Rotor -

#### Back-to-back flails on shackles -



184.618A(U)	Rotor 1.2m c/w Flails and end brg	1	
184.618B(W)	Rotor 1.52m c/w Flails and end brg		1
192.053	Spacer 12.5id	30	36
1920071	Flail for shackle	60	72
8095	Stiffnut M12 Nyloc Fine	30	36
1920069	Bolt M12 x 87 (10.9)	30	36
1920052	Shackle	30	36

#### Boot flails on shackles -



184.618A(V)	Rotor 1.2m c/w Flails and end brg	1	
184.618B(X)	Rotor 1.52m c/w Flails and end brg		1
192.053	Spacer 12.5id	30	36
1840605	Flail for shackle	30	36
8095	Stiffnut M12 Nyloc Fine	30	36
1920069	Bolt M12 x 87 (10.9)	30	36
1920052	Shackle	30	36

Both the above flail options can be fitted to the same rotor. This rotor is distinguishable from others in that the distance between lugs (inside to inside) is 53mm and the holes are for an M12 bolt.

### 184.619 Type Rotor -

#### Lump flails -

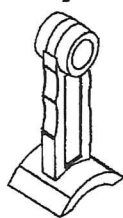

184.619A(C)	Rotor 1.2m c/w Flails and end brg	1	
184.619B(J)	Rotor 1.52m c/w Flails and end brg		1
184.106	Spacer 16.5id	24	30
1840093C	Flail Heavy Duty	24	30
7942	Stiffnut M16 Nyloc Fine	24	30
7943	Bolt M16 x 80 (10.9)	24	30

#### Heavy Duty Grass Flails -



184.619A(D)	Rotor 1.2m c/w Flails and end brg	1	
184.619B(K)	Rotor 1.52m c/w Flails and end brg		1
184.106	Spacer 16.5id	24	30
1840330	Flail Heavy Duty Grass	24	30
7942	Stiffnut M16 Nyloc Fine	24	30
7943	Bolt M16 x 80 (10.9)	24	30

## PARTS LIST FOR DS HEAD CONTINUED

### Rigid Back-to-Back Flails -

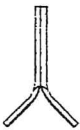
	184.619A(A)	Rotor 1.2m c/w Flails and end brg	1	
	184.619B(H)	Rotor 1.52m c/w Flails and end brg		1
	184.500	Spacer 16.5id	48	60
	1840497	Flail back to back	48	60
	7942	Stiffnut M16 Nyloc Fine	24	30
	7943	Bolt M16 x 80 (10.9)	24	30

All the above 3 flail options can be fitted to the same rotor. This rotor is distinguishable from others in that the distance between lugs (inside to inside) is 40mm and the holes are for an M16 bolt.

### 184.620 Type Rotor -

#### Rollicoupe flails

	184.620(G)	Rotor 1.2m c/w Flails and end brg	1	
	184.571	Spacer 16.5id	20	
	1840572	Flail Rollicoupe	20	
	3747	Stiffnut M16 Nyloc	20	
	8092U	Bolt M16 x 110 (10.9)	20	

This is a highly specialised rotor which accepts only the type of flail listed. The rotor's appearance is totally different from that indicated on pages 72, 74 and 76; as the structure resembles a large cylinder into which the flails can retract.

(For balanced 'bare' rotors the part numbers are as the 'flailed-up' rotor but with 'B' replacing the letter in the brackets. Example: balanced bare 1.2m rotor suitable for HD, HDG and rigid back-to-back flails = 184.619A(B).)



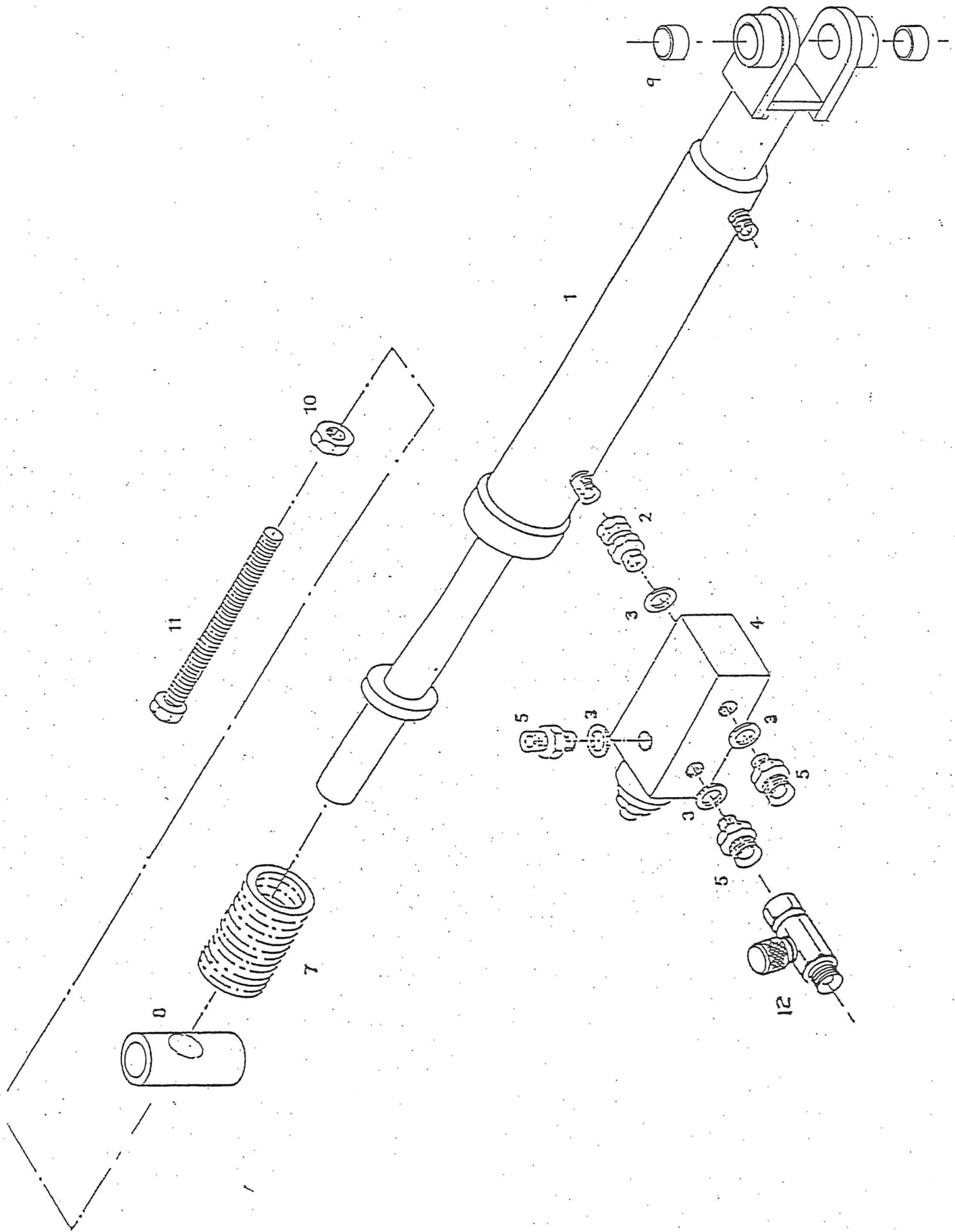

## BREKBACK RAM

<u>ITEM</u>	<u>PART NO.</u>	<u>DESCRIPTION</u>	<u>QTY</u>
1	1840507	Ram Breakback	1
*	1840507.1	Seal Set	
2	7305	Adaptor 1/4 BSP M-FLN	1
3	1181	Seal 1/4" Dowty Bonded	4
4	7484 R2000	Relief Block @ 2000 PSI (Relief block situated on Breakback cylinder - on electric machines only)	1

NOTE:- Relief Block situated on Breakback ram on electric machines only

NOTE:- For Forward Boom Machines this block is set to 3200 PSI (221 Bar) - Part No is then 7484 R3200

5	1823	Adaptor 1/4 BSP	3
7	7710	Spring - Die Blue	1
8	184.512	Pin Pivot Breakback 51 x 9.5 HFS x 74	1
9	6257N	Bush 4040m	2
10	2726	Locknut M20	2
11	7756	Setscrew M20 * 130 (8.8)	1
12	7814	1/4" BSP Pressure Test Point Fitting	1
*	004.393	1/4" Hose x 280 90 x 90 x 90o (5 to Ram Anchor End)	1

NOTE:- System Pressure at 7814 = (2000 PSI) (136 Bar)



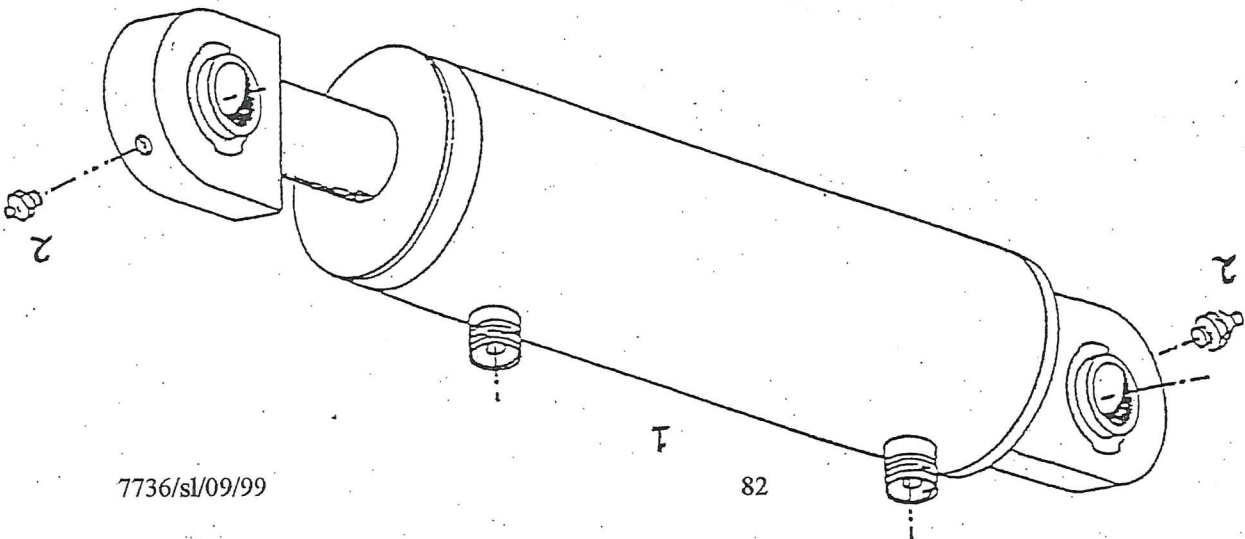
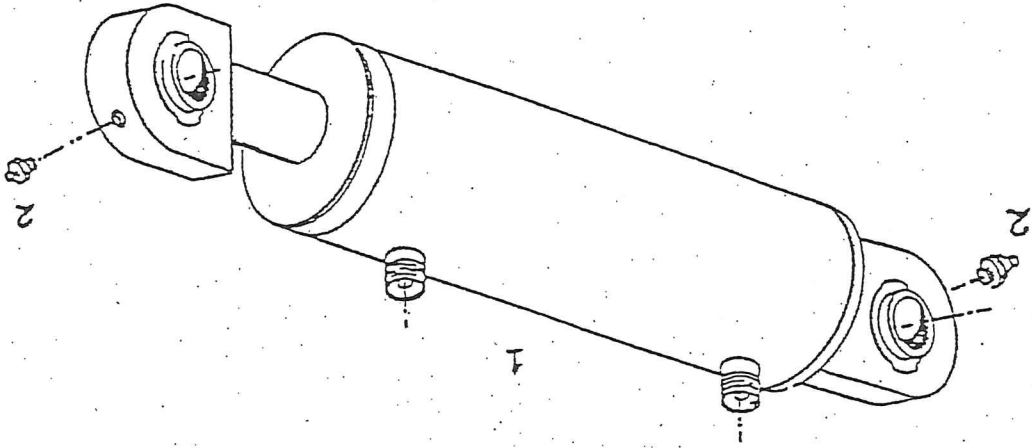

7736/sI/09/99

82

## PRIMARY RAM

<u>ITEM</u>	<u>PART NO.</u>	<u>DESCRIPTION</u>	<u>QTY</u>
1	1880063	Ram complete (Primary Ram)	1
*	1880063.1	Seal Set Complete	1
*	1880063.2	Rod Complete	1
*	1880063.3	Gland Nut	1
2	2923	Grease Nipple (M10)	2

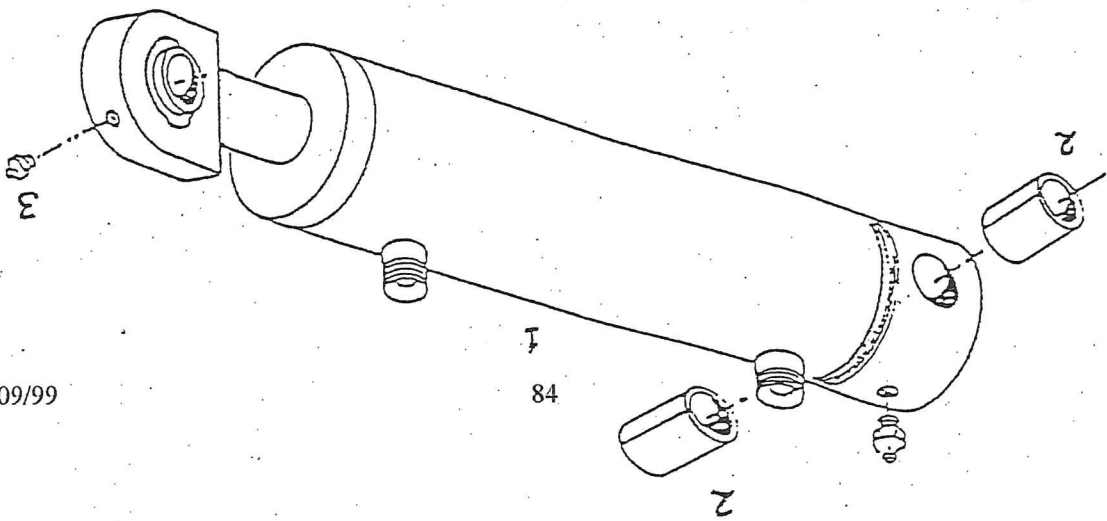
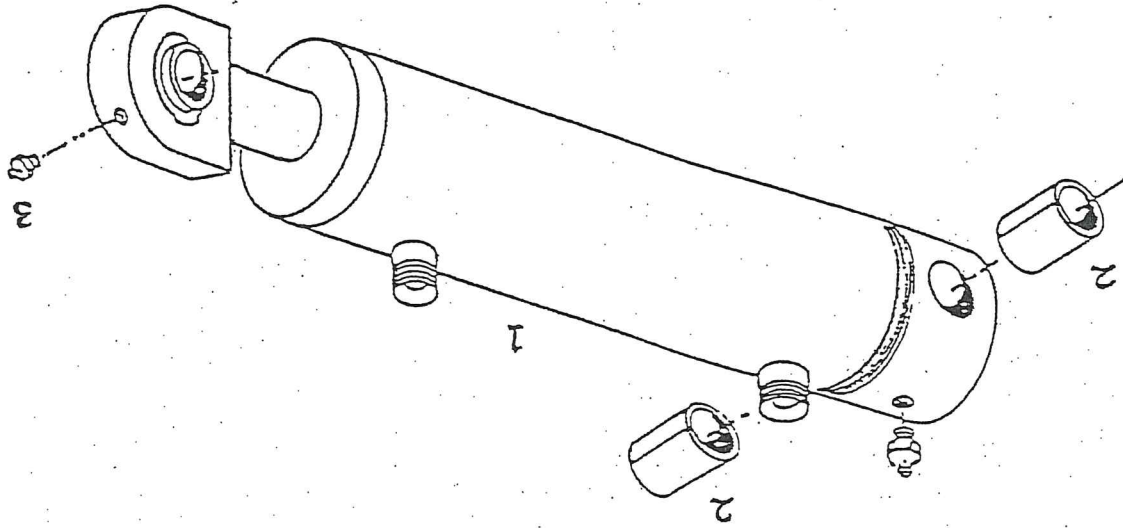

7736/sl/09/99

84

## SECONDARY RAM

<u>ITEM</u>	<u>PART NO.</u>	<u>DESCRIPTION</u>	<u>QTY</u>
1	1840229	Secondary Ram (460 & 520) (Rocker to first boom)	1
*	1840228.1	Seal Set	1
*	1840229.1	Rod Complete	1
*	1840228.3	Gland Nut	1
2	5178	Bush (3030m)	2
3	2923	Grease Nipple (M10)	2

<u>ITEM</u>	<u>PART NO.</u>	<u>DESCRIPTION</u>	<u>QTY</u>
1	1840557	Secondary Ram (580) (Rocker to first boom)	1
*	1840557.1	Seal Set	1
*	1840557.2	Rod Complete	1
*	1840557.3	Gland Nut	1
2	5178	Bush (3030m)	2
3	2923	Grease Nipple (M10)	2

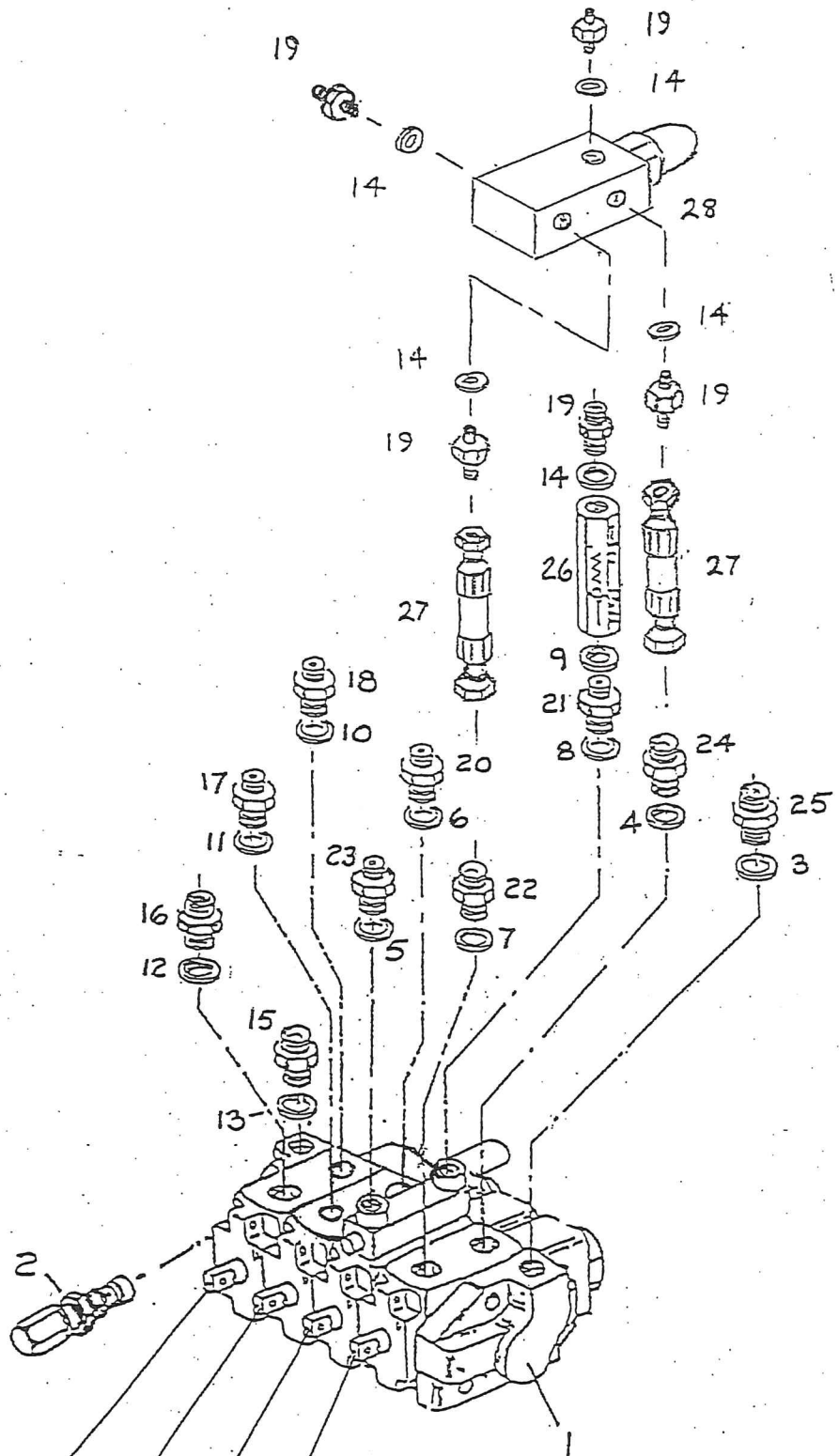

SECOND BOOM

HEAD ANGLING

MAIN RAM

BREAKBACK

## VALVE BLOCK

(FOR SEMI-INDEPENDENT MACHINES)

<u>ITEM</u>	<u>PART NO</u>	<u>DESCRIPTION</u>	<u>QTY</u>
1	7698	Valve block (Inc. Relief valve)	1
2	7698.4	Relief Valve (Spares only) set a 170 bar (2500 PSI)	1
3	0670	Seal 3/8" BSP	1
4	0670	Seal 3/8" BSP	1
5	0670	Seal 3/8" BSP	1
6	0670	Seal 3/8" BSP	1
7	0670	Seal 3/8" BSP	1
8	0670	Seal 3/8" BSP	1
9	1181	Seal 1/4" BSP	1
10	0670	Seal 3/8" BSP	1
11	0670	Seal 3/8" BSP	1
12	0670	Seal 3/8" BSP	1
13	0670	Seal 3/8" BSP	1
14	1181	Seal 1/4" BSP	5
15	0914	Adaptor 3/8" BSP x 1/2" BSP	1
16	1180	Adaptor 3/8" BSP x 1/4" BSP	1
17	1180	Adaptor 3/8" BSP x 1/4" BSP	1
18	1180	Adaptor 3/8" BSP x 1/4" BSP	1
19	1823	Adaptor 1/4" BSP x 1/4" BSP	5
20	1180	Adaptor 3/8" BSP x 1/4" BSP	1
21	1180	Adaptor 3/8" BSP x 1/4" BSP	1
22	1180	Adaptor 3/8" BSP x 1/4" BSP	1
23	1180	Adaptor 3/8" BSP x 1/4" BSP	1
24	1180	Adaptor 3/8" BSP x 1/4" BSP	1
25	0914	Adaptor 3/8" BSP x 1/2" BSP	1
26	7813	Restrictor (1 way) 1.8 (0.5 bar)	1
27	7861	Flow Control Valve V1729(CV1060) @ 2.0-2.5 Gall per min	1
28	0934	Seal 3/4" BSP	1
29	1830	Adaptor 3/8" BSP x 3/4" BSP	1



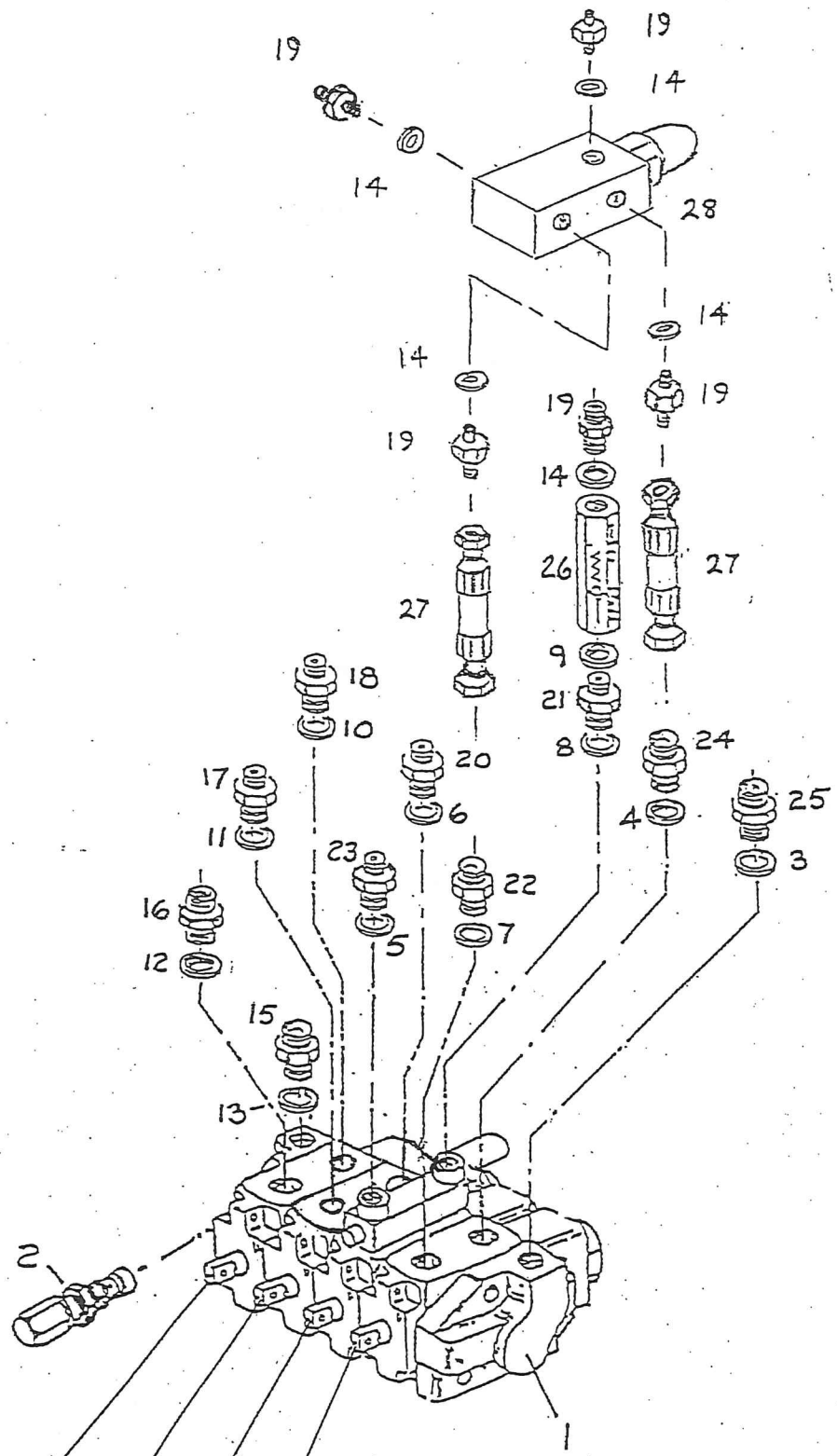

SECOND BOOM  
 HEAD ANGLING  
 MAIN RAM  
 BREAKBACK

## VALVE BLOCK

(FOR SEMI-INDEPENDENT MACHINES)

<u>ITEM</u>	<u>PART NO</u>	<u>DESCRIPTION</u>	<u>QTY</u>
30	0909	Seal 1/2" BSP	1
31	0909	Seal 1/2" BSP	1
32	1826	Adaptor 1/2" BSP x 1/2" BSP	1
33	4927	Adaptor 1/2" BSP M-FLN	1
34	5860	Adaptor 1/2" BSP M-FLN 91	1
35	5002	Tee 1/2" BSP M-F-M	1
36	004.439	1/4 Hose x 75, St x ST	2
37	7484 R2000	Relief Block @ 2000 PSI (Relief block situated on valve block on non-electric machines only).	1
*	004.441	1/2" Hose x 370, 90 x ST (From leg of Tee 5002 to 1826- - in Flow Control Valve)	1

### VALVE BLOCK MOUNTING PLATE AND SCREWS (NOT SHOWN - \*

*	2793	Setscrew M8 x 20 (8.8)	4
*	3111	Washer M8 Form 'A'	4
*	3001	Washer M8 Spring	4
*	184.409	Valve block mounting plate	1

NOTE:- Drawing shows valve set for 'GREY' cables  
(TELE-MECANIQUES)

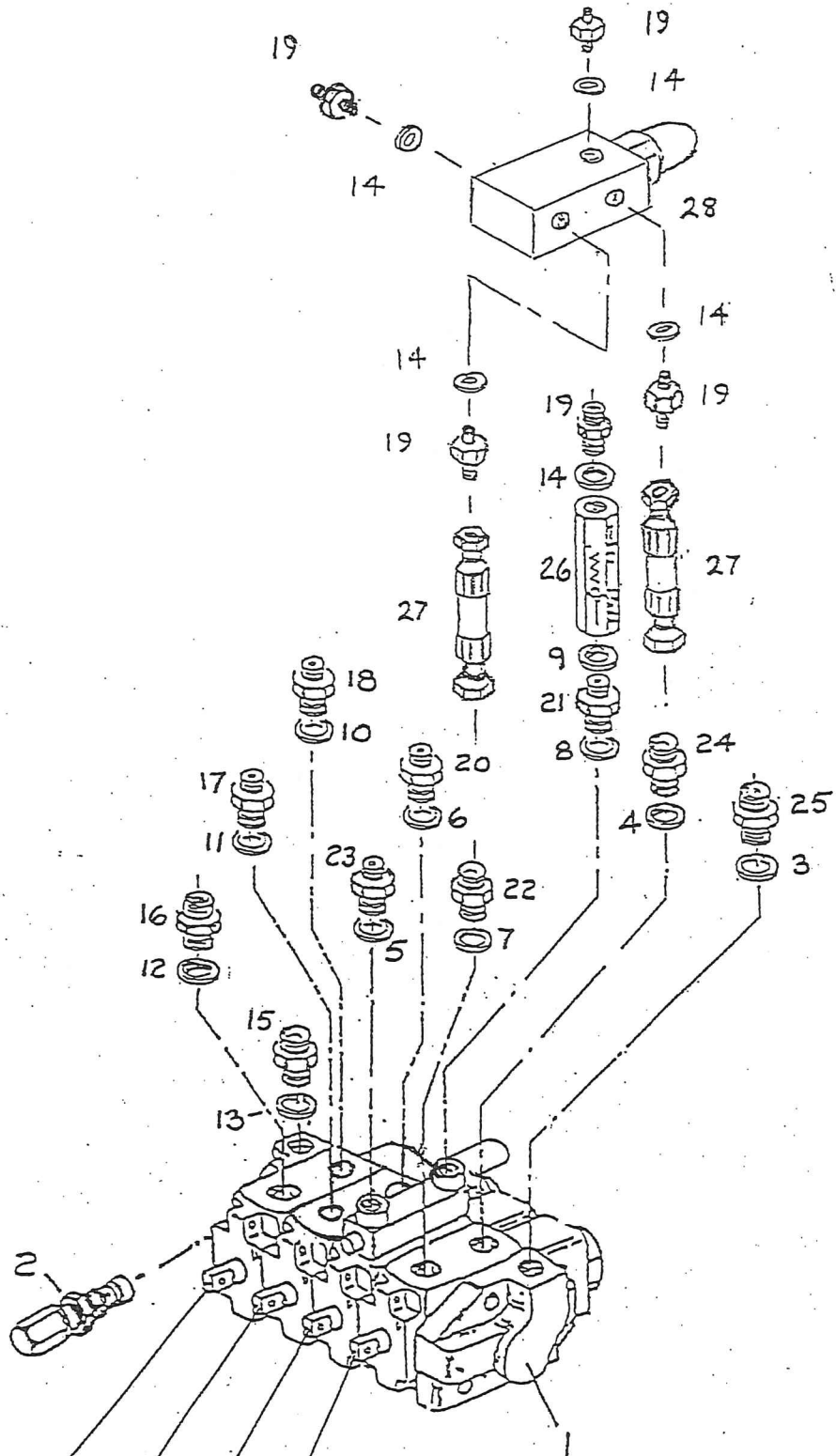

SECOND BOOM

HEAD ANGLING

MAIN RAM

BREAKBACK

VALVE BLOCK  
(FOR INDEPENDENT HYDRAULIC MACHINES)

<u>ITEM</u>	<u>PART NO</u>	<u>DESCRIPTION</u>	<u>QTY</u>
1	7698	Valve block (Inc. Relief valve)	1
2	7698.4	Relief Valve (Spares only) set a 170 bar (2500 PSI)	1
3	0670	Seal 3/8" BSP	1
4	0670	Seal 3/8" BSP	1
5	0670	Seal 3/8" BSP	1
6	0670	Seal 3/8" BSP	1
7	0670	Seal 3/8" BSP	1
8	0670	Seal 3/8" BSP	1
9	1181	Seal 1/4" BSP	1
10	0670	Seal 3/8" BSP	1
11	0670	Seal 3/8" BSP	1
12	0670	Seal 3/8" BSP	1
13	0670	Seal 3/8" BSP	1
14	1181	Seal 1/4" BSP	5
15	0914	Adaptor 3/8" BSP x 1/2" BSP	1
16	1180	Adaptor 3/8" BSP x 1/4" BSP	1
17	1180	Adaptor 3/8" BSP x 1/4" BSP	1
18	1180	Adaptor 3/8" BSP x 1/4" BSP	1
19	1823	Adaptor 1/4" BSP x 1/4" BSP	5
20	1180	Adaptor 3/8" BSP x 1/4" BSP	1
21	1180	Adaptor 3/8" BSP x 1/4" BSP	1
22	1180	Adaptor 3/8" BSP x 1/4" BSP	1
23	1180	Adaptor 3/8" BSP x 1/4" BSP	1
24	1180	Adaptor 3/8" BSP x 1/4" BSP	1
25	0914	Adaptor 3/8" BSP x 1/2" BSP	1
26	7813	Restrictor (1 way) 1.8 (0.5 bar)	1
27	004.439	1/4 Hose x 75, ST x ST	2
28	7484 R2000	Relief Block @ 2000 PSI (Relief block situated on valve block on non-electric machines only)	1

VALVE BLOCK MOUNTING PLATE AND SCREWS (NOT SHOWN - \*)

*	2793	Setscrew M8 x 20 (8.8)	4
*	3111	Washer M8 Form 'A'	4
*	3001	Washer M8 Spring	4
*	184.409	Valve block mounting plate	1

NOTE:- Drawing shows valve set for 'GREY' cables (TELE-MECANIKUES).

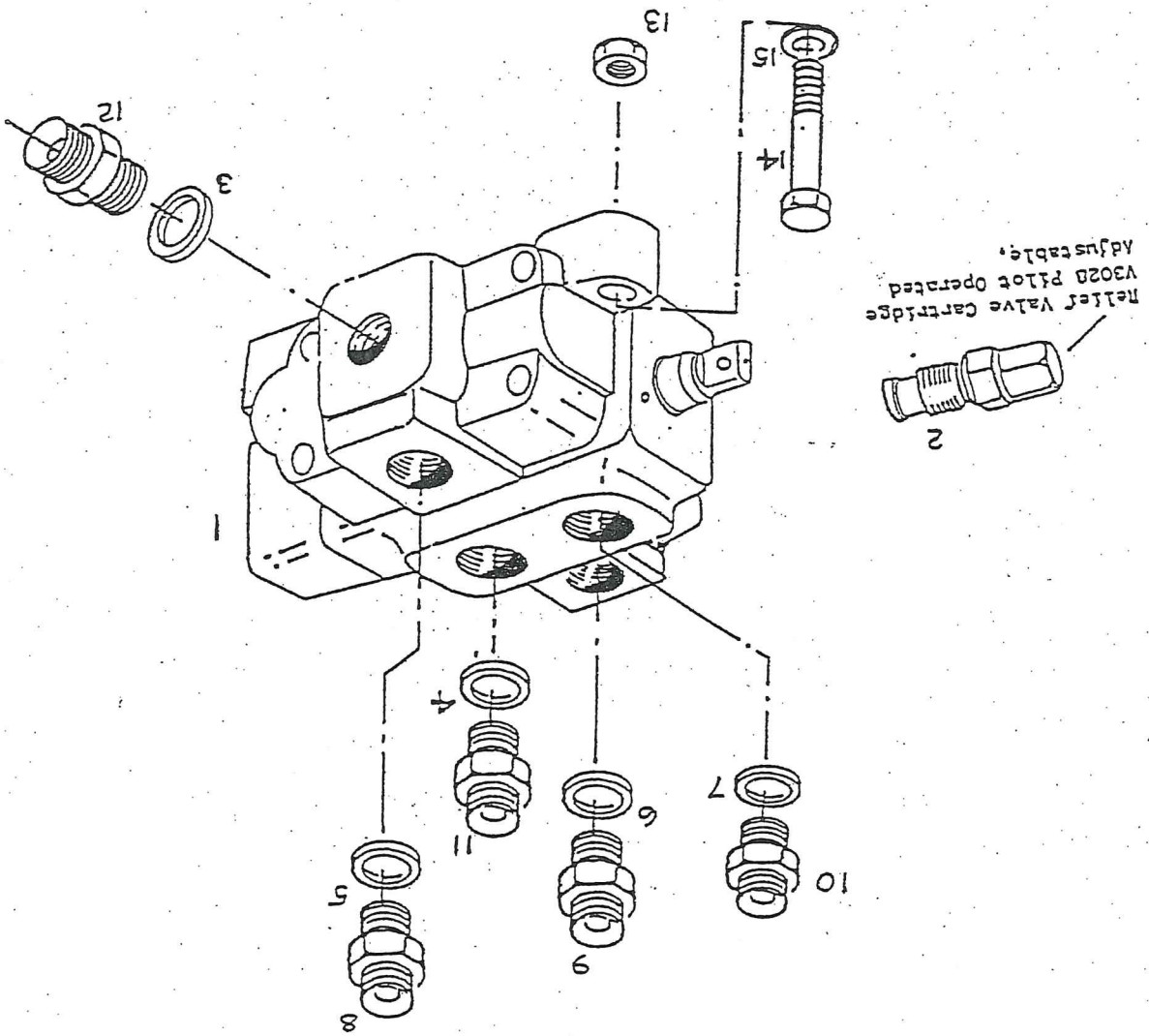

## MOTOR SPOOL VALVE (HEAD ROTOR DRIVE)

<u>ITEM</u>	<u>PART NO</u>	<u>DESCRIPTION</u>	<u>QTY</u>
1	7542 R225	Valve Block (c/w Relief Valve)	1
2	7542.1	Relief Valve (Spares only)	1
3	0909	Seal 1/2" B.S.P	1
4	1934	Seal 3/4" B.S.P	1
5	1934	Seal 3/4" B.S.P	1
6	1934	Seal 3/4" B.S.P	1
7	1934	Seal 3/4" B.S.P	1
8	1836	Adaptor 3/4" B.S.P X 1" B.S.P	1
9	0935	Adaptor 3/4" B.S.P X 3/4" B.S.P	1
10	0935	Adaptor 3/4" B.S.P X 3/4" B.S.P	1
11	0935	Adaptor 3/4" B.S.P X 3/4" B.S.P	1
12	1826	Adaptor 1/2" B.S.P X 1/2" B.S.P	1
13	3182	Stiffnut M8 Nyloc	3
14	3183	Bolt M8 x 45 (8.8)	3
15	3111	Washer-Float M8 (Form A)	3



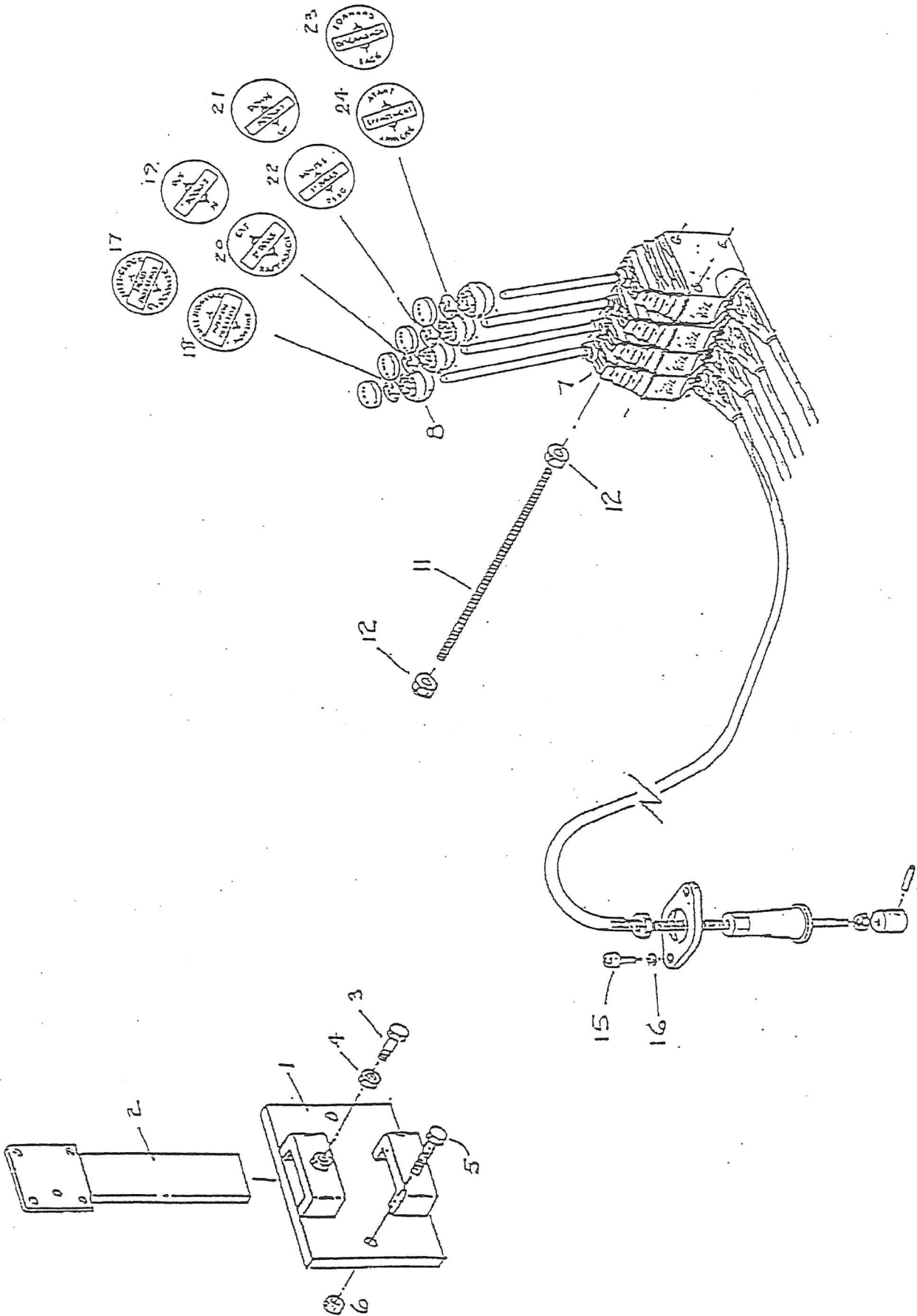

## CONTROL LEVERS AND MOUNTING (T.M.C CONTROLLERS)

### BLACK CABLES

<u>ITEM</u>	<u>PART NO</u>	<u>DESCRIPTION</u>	<u>QTY</u>
1	184.257	Mounting Bracket - "to tractor"	
2	184.258	Controller Support Bracket	1
3	2962	Setscrew M12 x 3 5	1
4	2721	Nut M12	1
5	3730	Setscrew M8 x 40	2
6	3182	Nyloc Nut M8	2

### 4 BANK CONTROLLERS ONLY (AS FOR 'R' MACHINES)

7	7822	Complete Controller	
8	7835	Knob - (black) with lens	4
11	184.481 A	Tie Bolt-Stud (M6 x 190)	3
12	4776	M8 Nyloc Stiffnut	6
15	4695	Caphead Screw M6 x 15	8
16	2731	Spring Washer M6	8
17	1840501	Head Rotating "Transfer" (English)	1
18 OR	1840501F	Head Rotating "Transfer" (French)	1
19	1840374	Boom '2' Transfer (English)	1
20 OR	1840374F	Boom '2' Transfer (French)	1
21	1840373	Boom '1' Transfer (English)	1
22 OR	1840373F	Boom '1' Transfer (French)	1
23	1840372	Breakback Transfer (English)	1
23 OR	1840372F	Breakback Transfer (French)	1



5-BANK CONTROLLERS (AS FOR RI) MACHINES  
(T.M.C CONTROLLERS)

BLACK CABLES

ITEM	PART NO	DESCRIPTION	QTY
7	7822	Complete Controller	
8	7835	Knob (Black) with lens	4
9	7836	Knob (Red) with lens	1
11	184.481B	Tie bolt stud (M6 x 275)	3
12	4776	M6 Nyloc Stiffhut	6
15	4695	Caphead Screw M6 x 15	10
16	2731	Spring Washer M6	10
17	1840375	Head Rotating Transfer (English)	1
18	1840375F	Read Rotating Transfer (French)	1
19	1840374	Boom '2' Transfer (English)	1
20	1840374F	Boom '2' Transfer (French)	1
21	1840373	Boom '1' Transfer (English)	1
22	1840373F	Boom '1' Transfer (French)	1
23	1840372	Breakback Transfer (English)	1
24	1840372F	Breakback Transfer (French)	1
25	1840371	Rotation-cut Transfer (English)	1
26	1840371F	Rotation-cut Transfer (French)	1
27	7823	Controller Complete (Baulk Lock)	1

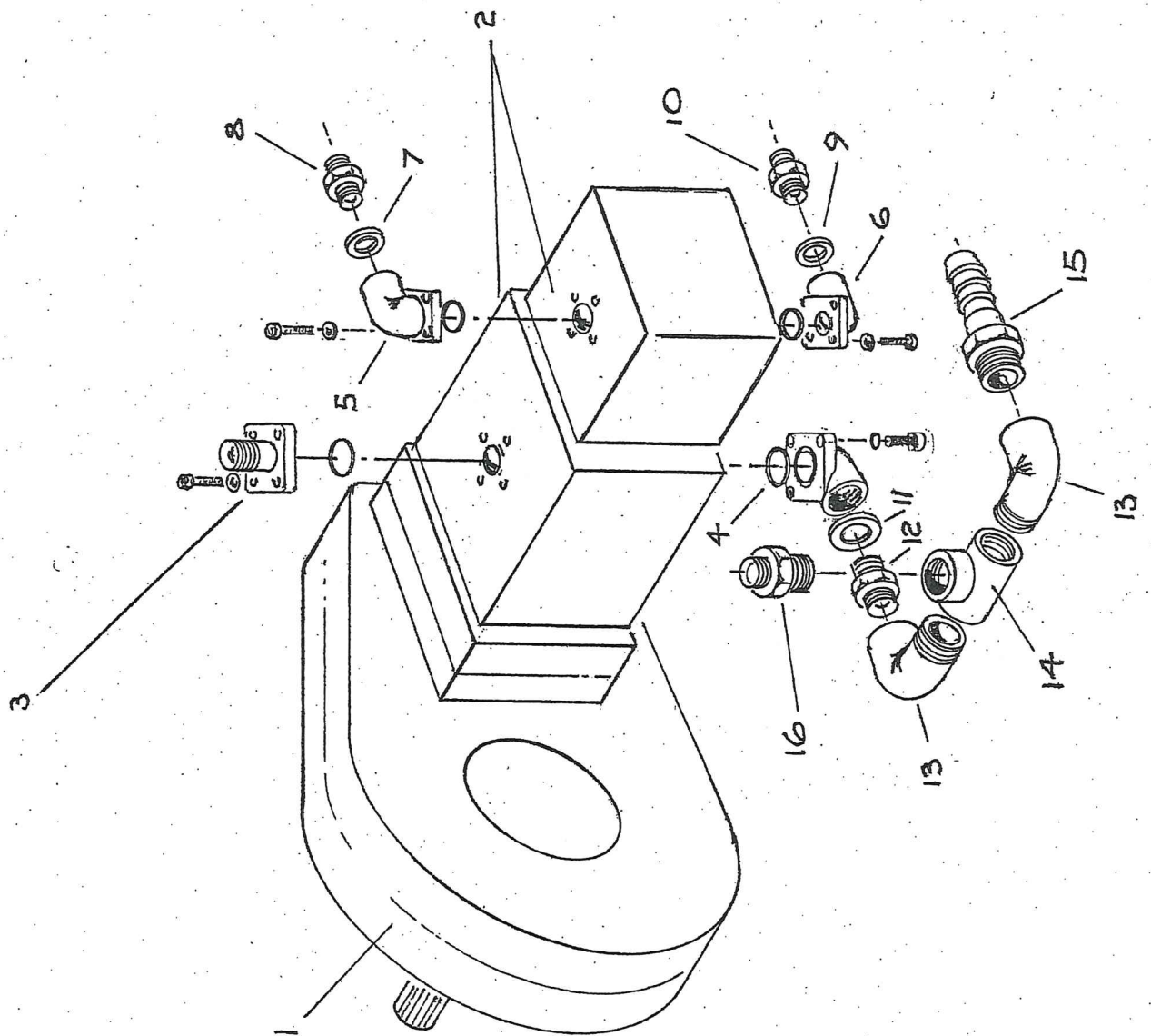

POWER PACK - Including:- PTO Gearbox, Pumps and Fittings

<u>ITEM</u>	<u>PART NO</u>	<u>DESCRIPTION</u>	<u>QTY</u>
1	194.056	P.T.O Gearbox (Manufactured from 8119)	1
*	8159	'O' Ring (to Gearbox flange)	1
2	7939 (41.0.0)	Gear Pump (Standard) (184*R)	1
OR	7939 (41C.8.0)	Pumps Dual (Cast/Alumin) (184*RI, 184*RIE)	1
OR	7939 (41C.16.0)	Pumps Dual (Cast/Alumin) (184*RIEP)	1
3	7939-E06S	Elbow 3/4" IPE6 straight + 'O' ring + 6/16" screws	1
4	7939-E08	Elbow 1" IPE8 c/w 'O' ring + M10 screws	1
5	7939-E04	Elbow 1/2" IPE4 c/w 'O' ring + 5/16" screws	1
6	7939-E06	Elbow 3/4" IPE6 c/w 'O' ring + 5/16" screws	1
7	0909	Seal 1/2"	1
8	1826	Adaptor 1/2" x 1/2" BSP	1
9	0934	Seal 3/4"	1
10	0935	Adaptor 3/4" x 3/4" BSP	1
11	1934	Seal 1"	1
12	7559	Adaptor 1" x 1 1/2" T BSP	1
13	8002	Adaptor 1 1/2" M-F BSPT 90	2
14	8001	Tee 1 1/2" F/F/F	1
15	7999	Hose Tail 1 1/2" BSP (Male)	1
16	8010	Adaptor 3/4" BSP x 1 1/2" BSPT	1





## SET OF HOSES FOR 460R

<u>COMPONENT ITEM</u>	<u>DESCRIPTION</u>	<u>QTY PER</u>
004.316	Hose 3/4 ST x 90 X 1570 --- Pump to Anti Cav	1
004.375	Hose 1/2 ST x ST x 1750 --- Service Hose	1
004.376	Hose 3/8 ST x ST x 1750 --- Service Hose	1
004.411	Hose 1/4 90 x 90 x 300 --- 1st Ram Rod	1
004.412	Hose 1/4 90 x 90 x 480 @180 --- 1st Ram Anch	1
004.415	Hose 1/4 90 x 90 x 1200 @180 --- 2nd Ram Anch	1
004.416	Hose 1/4 90 x 90 x 1400 @ 180 --- 2nd Ram Rod	1
004.431	Hose 3/4 ST x ST x 5820 --- Anticav to Motor	2
004.434	Hose 1/4 ST x 90 x 4800 --- Head Angle Rod	2
004.439	Hose 1/4 ST x ST x 75 --- V1 Block to BB slice	2
004.441	Hose 1/2 ST x 90 x 370 --- Flow Cont.->Tee 5002	1
004.443	Hose 1/4 90 x 90 x 1500 @ 270 --- Valve to BBack Block	2
8000	Hose suction 38mm id --- Suction line	0.55MT

## SET OF HOSES FOR 460RI

<u>COMPONENT ITEM</u>	<u>DESCRIPTION</u>	<u>QTY PER</u>
004.364	Hose 1/2 ST x 90 x 700 --- 2nd pump -> V1 Block	1
004.365	Hose 1 ST x 90 x 480 --- Ret V3 Block -> Filter	1
004.405	Hose 3/4 90 x 90 x 1230 --- 1st Pump -> V3 block	1
004.408	Hose 1/2 ST x 90 x 240 --- Return V1 -> V3 blocks	1
004.411	Hose 1/4 90 x 90 x 300 --- 1st Ram Rod	1
004.412	Hose 1/4 90 x 90 x 480 @180 --- 1st Ram Anch	1
004.415	Hose 1/4 90 x 90 x 1200 @180 --- 2nd Ram Anch	1
004.416	Hose 1/4 90 x 90 x 1400 @180 --- 2nd Ram Rod	1
004.431	Hose 3/4 ST x ST x 5820 --- V3 To Motor	2
004.439	Hose 1/4 ST x ST x 75 --- V1 Block to BB slice	2
004.434	Hose 1/4 ST x 90 x 4800 --- Head Angle Rod	2
004.443	Hose 1/4 90 x 90 x 1500 --- Valve to BBack Block	2
004.572	Hose 3/4 ST x 90 x 420 --- 2nd pump suction	2
8000	Hose suction 38mm id --- Suction line	0.56MT

## SET OF HOSES FOR 520R

<u>COMPONENT ITEM</u>	<u>DESCRIPTION</u>	<u>QTY PER</u>
004.316	Hose 3/4 ST x 90 X 1570 --- Pump to Anti Cav	1
004.375	Hose 1/2 ST x ST x 1750 --- Service Hose	1
004.376	Hose 3/8 ST x ST x 1750 --- Service Hose	1
004.411	Hose 1/4 90 x 90 x 300 --- 1st Ram Rod	1
004.412	Hose 1/4 90 x 90 x 480 @180 --- 1st Ram Anch	1
004.415	Hose 1/4 90 x 90 x 1200 @180 --- 2nd Ram Anch	1
004.416	Hose 1/4 90 x 90 x 1400 @ 180 --- 2nd Ram Rod	1
004.432	Hose 3/4 ST x ST x 6400 --- V3 to Motor	2
004.436	Hose 1/4 ST x 90 x 5650 --- Head Angle Rod	2
004.439	Hose 1/4 ST x ST x 75 --- V1 Block to BB slice	2
004.441	Hose 1/2 ST x 90 x 370 --- Flow Cont. -> Tee 5002	1
004.443	Hose 1/4 90 x 90 x 1500 --- Valve to BBack Block	2
8000	Hose suction 38mm id --- Suction Line	0.55MT

## SET OF HOSES FOR 520RI

<u>COMPONENT ITEM</u>	<u>DESCRIPTION</u>	<u>QTY PER</u>
004.364	Hose 1/2 ST x 90 x 700 --- 2nd Pump-> V1 Block	1
004.365	Hose 1 ST x 90 x 480 --- Ret V3 Block -> Filter	1
004.405	Hose 3/4 90 x 90 x 1230 --- 1st Pump -> V3 block	1
004.408	Hose 1/2 ST x 90 x 240 --- Return V1 to V3 block	1
004.411	Hose 1/4 90 x 90 x 300 --- 1st Ram Rod	1
004.412	Hose 1/4 90 x 90 x 480 @180 --- 1st Ram Anch	1
004.415	Hose 1/4 90 x 90 x 900 @180 --- 2nd Ram Anch	1
004.416	Hose 1/4 90 x 90 x 1400 @180 --- 2nd Ram Rod	1
004.432	Hose 3/4 ST x ST x 6400 --- V3 to Motor	2
004.436	Hose 1/4 ST x 90 x 5650 --- Head Angle Rod	2
004.439	Hose 1/4 ST x ST x 75 --- V1 Block to BB slice	2
004.443	Hose 1/4 90 x 90 x 1500 --- Valve to BBack Block	2
004.572	Hose 3/4 ST x 90 x 420 --- 2nd pump suction	1
8000	Hose suction 38mm id --- Suction line	0.56MT

## SET OF HOSES FOR 580R

<u>COMPONENT ITEM</u>	<u>DESCRIPTION</u>	<u>QTY PER</u>
004.316	Hose 3/4 ST x 90 x 1570 --- Pump to Anti Cav	1
004.375	Hose 1/2 ST x ST x 1750 --- Service Hose	1
004.376	Hose 3/8 ST x ST x 1750 --- Service Hose	1
004.411	Hose 1/4 90 x 90 x 300 --- 1st Ram rod	1
004.412	Hose 1/4 90 x 90 x 480 @ 180 --- 1st Ram Anch	1
004.439	Hose 1/4 ST x ST x 75 --- V1 Block to BB Slice	2
004.441	Hose 1/2 ST x 90 x 370 --- Flow Cont. -> Tee 5002	1
004.443	Hose 1/4 90 x 90 x 1500 --- Valve to BBack Block	2
004.517	Hose 1/4 ST x 90 x 6070 --- Head angle	2
004.518	Hose 3/4 ST x ST x 7500 --- V3 to motor	2
004.415	Hose 1/4 90 x 90 x 1200 @ 180 --- 2nd ram anchor	1
004.416	Hose 1/4 90 x 90 x 1400 @ 180 --- 2nd Ram Rod	1
8000	Hose Suction 38mm id --- Suction line	0.55MT



## SET OF HOSES FOR 580RI

<u>COMPONENT ITEM</u>	<u>DESCRIPTION</u>	<u>QTY PER</u>
004.364	Hose 1/2 ST x 90 x 700 --- 2nd pump-> V1 Block	1
004.365	Hose 1 ST x 90 x 480 --- Ret V3 Block-> Filter	1
004.405	Hose 3/4 90 x 90 x 1230 --- 1st Pump-> V3 Block	1
004.408	Hose 1/2 ST x 90 x 240 --- Return V1 to V3 Block	1
004.411	Hose 1/4 90 x 90 x 300 --- 1st Ram rod	1
004.412	Hose 1/4 90 x 90 x 480 @ 180 --- 1st Ram Anch	1
004.439	Hose 1/4 ST x ST x 75 --- V1 Block to BB Slice	2
004.443	Hose 1/4 90 x 90 x 1500 --- Valve to BBack Block	2
004.517	Hose 1/4 ST x 90 x 6070 --- Head Angle	2
004.518	Hose 3/4 ST x ST x 7500 --- V3 to motor	2
004.415	Hose 1/4 90 x 90 x 1200 @ 180 --- 2nd ram anchor	1
004.416	Hose 1/4 90 x 90 x 1400 @ 180 --- 2nd Ram rod	1
004.572	Hose 3/4 ST x 90 x 420 --- 2nd Pump Suction	1
8000	Hose Suction 38mm id --- Suction line	0.56MT

# ELECTRONIC PROPORTIONAL CONTROL BOOM FLAIL

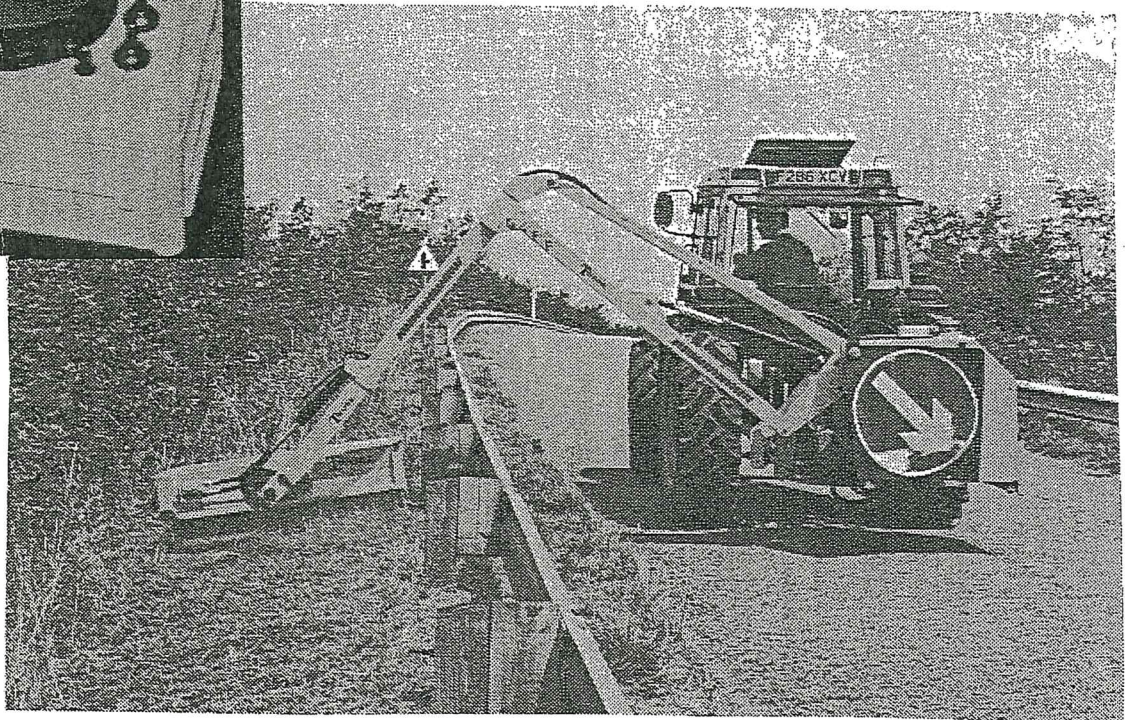
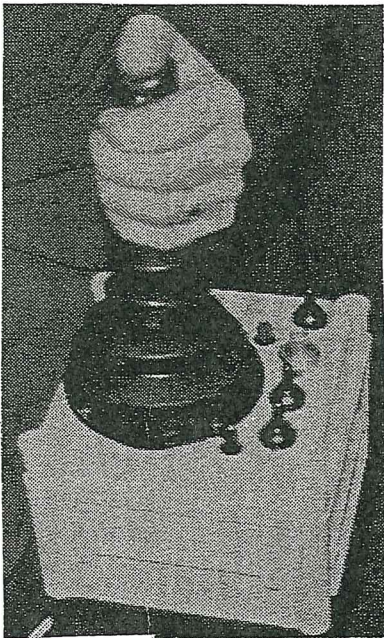

## ELECTRIC CONTROL MACHINE

The electronic - proportional valve control boom flails feature at the upper end of the Twose flail range.

These models include all basic specifications as listed for non- electric control machines but - have the added advantages of:-

1. Fingertip - Joystick control
2. Proportional valve control
3. Power float facility

The main hardmetal components - such as Tank, Booms, Head etc. remain unchanged as only controls and specification alter.

The power supply required to operate the electrical components - proportional valves etc, is taken from the tractor 7 pin rear trailer socket. The side light terminals being the contact points used as power supply, which means therefore that tractor side lights MUST be ON at all times that flail is used.

The power float system incorporated to enable 'more' or 'less' pressure to head contact to floor. This system will reduce downward weight - pressure and therefore reduce 'drag' on head, which in turn protects the booms and pivots by reducing load on each item/component.



## ATTACHING 'ELECTRIC' BOOM FLAIL MACHINE TO TRACTOR

DANGER      ENSURE AREA WHERE COUPLE-UP OPERATION IS TO TAKE PLACE IS CLEAR AND FREE FROM OBJECTS AND BYSTANDERS

DANGER  
IMPORTANT      ASSURE FLAIL IS PARKED ON GOOD LEVEL - SOLID SITE

NOTE      The electric joystick control lever box is supplied from the factory "as a complete assembly" which will be already bolted to its mounting stand.

First - the control box locating bracket should be positioned to inner wing face at a suitable position to suit operator/lever operation. Secure support bracket to wing in chosen/selected position with bolts. Fixing of this bracket will depend on whether machine is L.H or R.H cut.

- For left hand cut machines - fit support bracket to inner face of nearside wing.
  
- For right hand cut machines - fit support bracket to inner face of offside wing.

With support bracket secured into position (to inner wing) - the control box mounting leg should be lowered into slot of locating bracket (see drawing below) and secured by tightening screw 'X' clockwise.

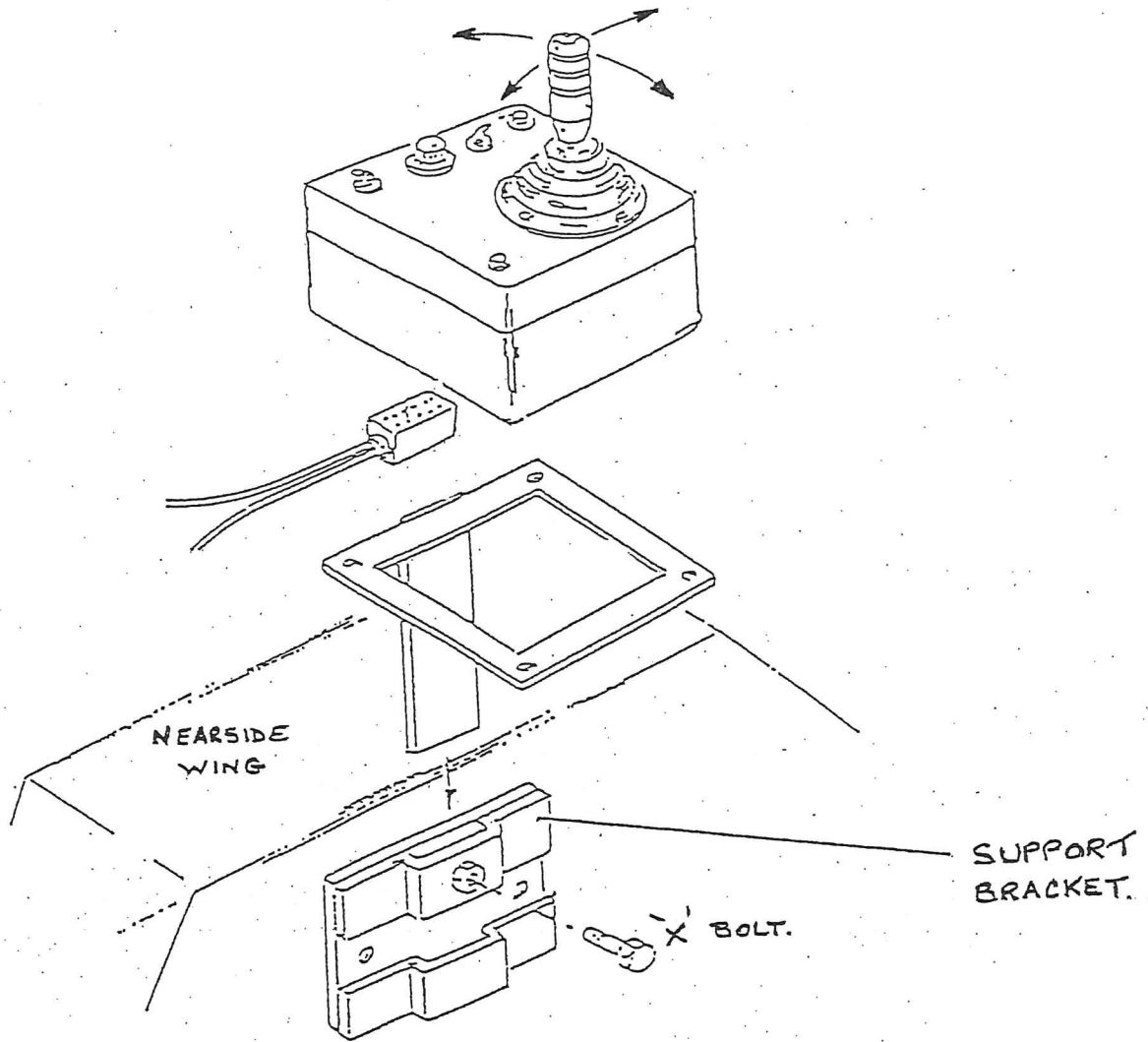

Drawing shows layout of electrical control box fitted to inner nearside wing - to suit a lefthand cut machine.

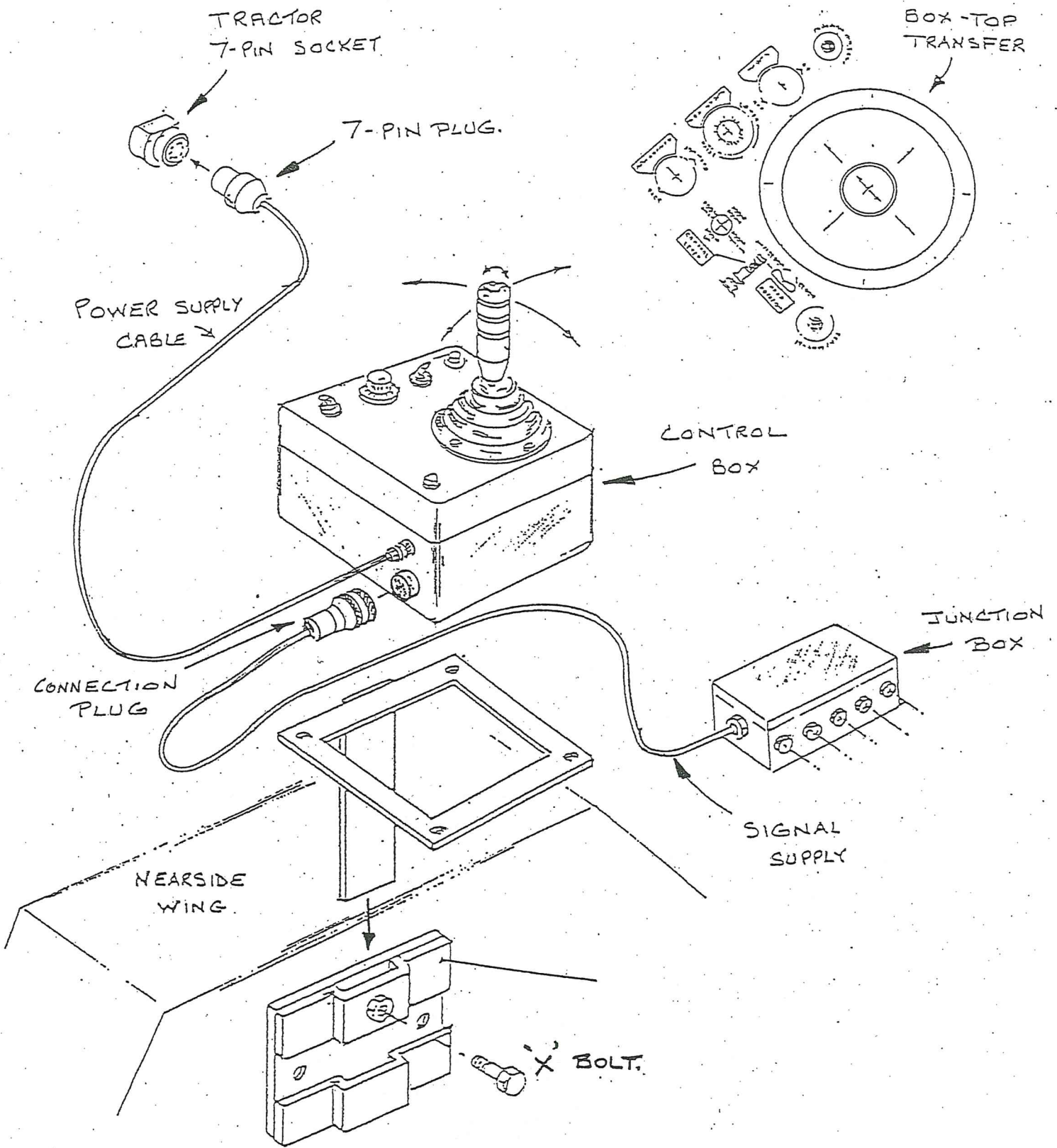



MAIN FLOAT (RED LAMP) [only required when Bank/verge cutting]

- 1/ Ensure head is resting on floor.
- 2/ Switch float ON (red light will show) see drawing below for ref. to switch and lamp.
- 3/ Adjust float pressure by turning potentiometer knob either clockwise for lighter/raise, or anti-clockwise for heavier/down pressure.  
(Drawing below indicates float control section.)

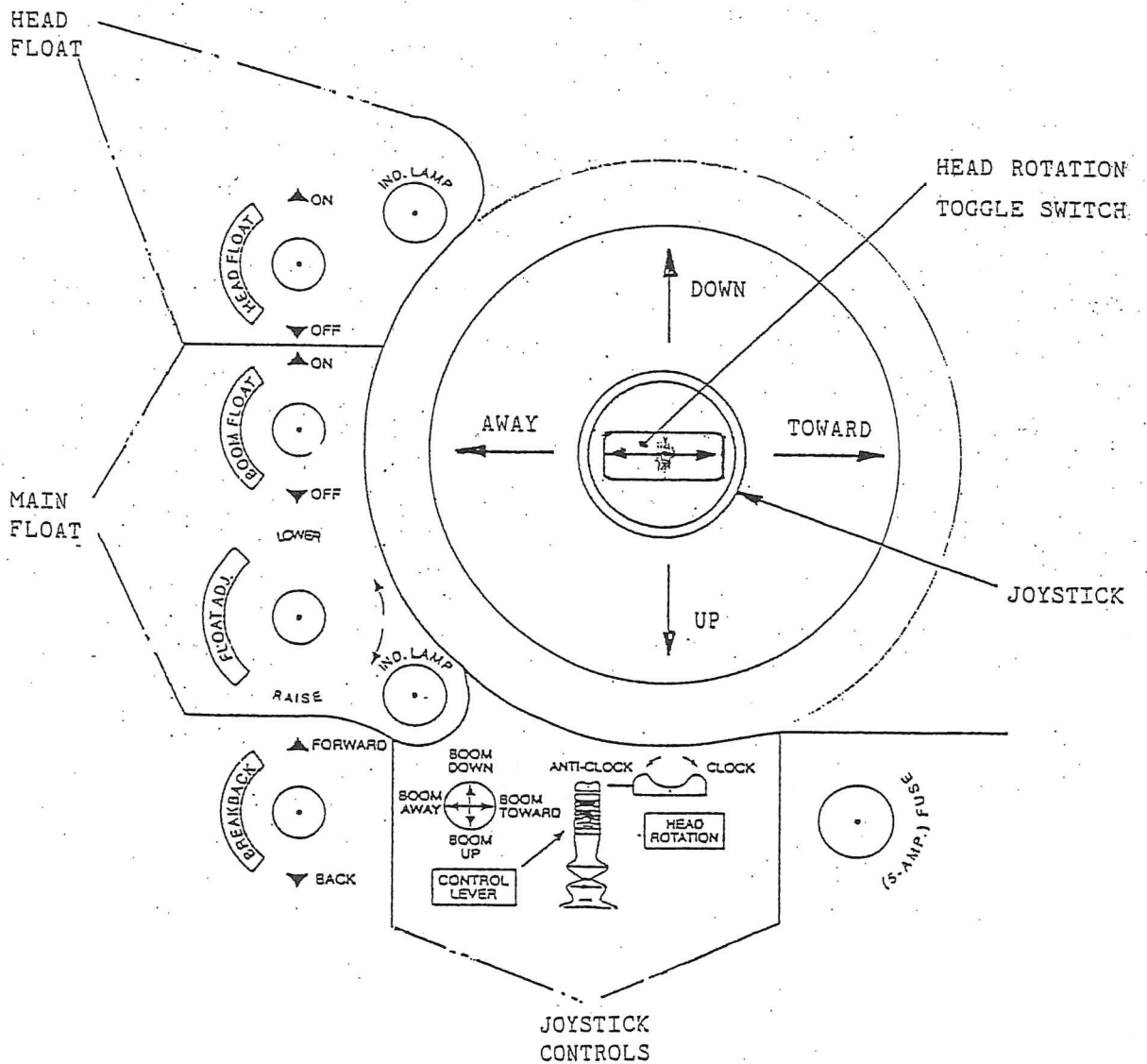

## IMPORTANT

Note ensure setting of float gives a 'JUST HEAVY' position to prevent machine rising from work. By turning clockwise to find where machine rises and then turning anti clock to lower machine back to floor and then - add just a little more anti clock to settle (approx 1/2 of a turn). (Final tuning must always be down to the individual operator).

Float can be overridden by moving joystick handle to raise or lower position. On returning joystick back to its neutral- central position the float will automatically come back into position.

NOTE:- If head is raised from the ground '(with float switch ON)' and handle is returned to neutral position - the head will gradually return to the floor, at this time normal float conditions will resume.

## VERY IMPORTANT

Float switch must be in 'OFF' position if float not required.

### HEAD FLOAT (Blue lamp)

Switch head float switch ON - (blue lamp will show)

-See drawing Page

This float allows head only to float about its centre pivot axis.

Note:- after prolonged use of float usage on banks/verges etc, a slight delay may occur when joystick top rocker switch is energised for head rotation (to recharge system).

## VERY IMPORTANT

Float switch must be 'OFF' if float not required.

--- \* ---

## FUSE

Electrical system is protected by a 5 amp fuse (1in x 1/4in) BS1362.

--- \* ---

## EMERGENCY - MANUAL CONTROL LEVER (ELECTRIC MACHINE)

The Hydraulic Proportional Valve has a manual - control lever (included with every Electric Control Trimmer) which can be used should the Electronic System fail and not function. This manual option enables user/operator to operate Hydraulics and fold machine in order to move from site.

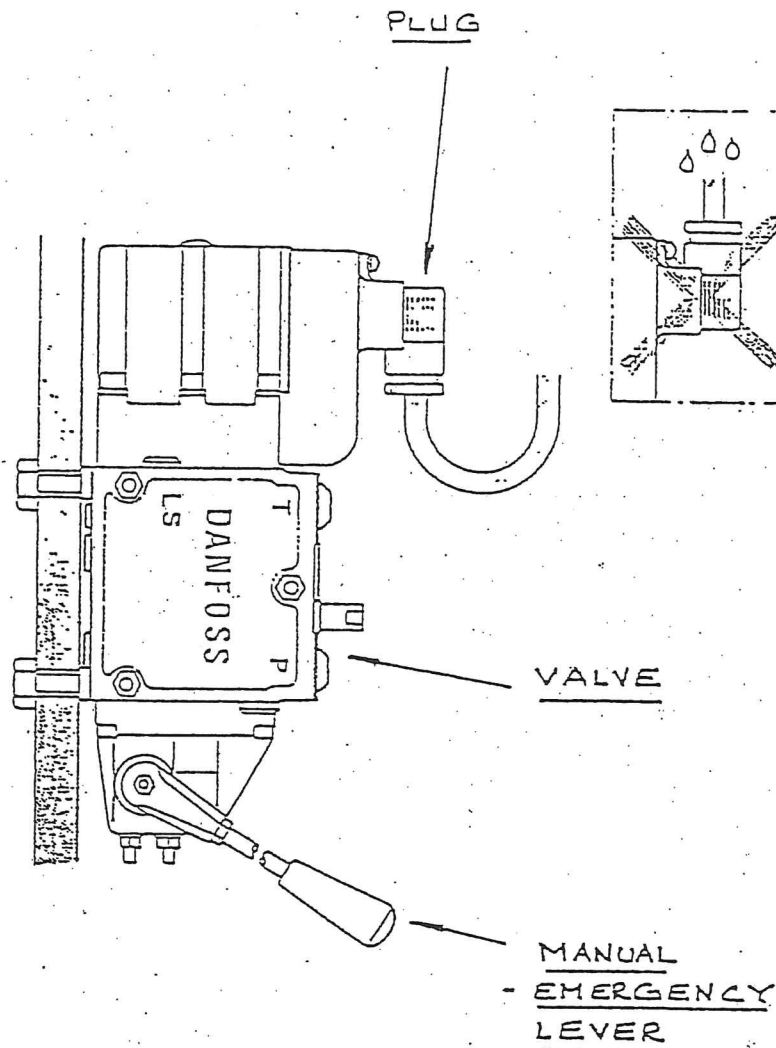

NOTE:- This Emergency valve lever will only function and operate machine provided Hydraulic system is working.





HYDRAULIC AND ELECTRICAL CIRCUIT

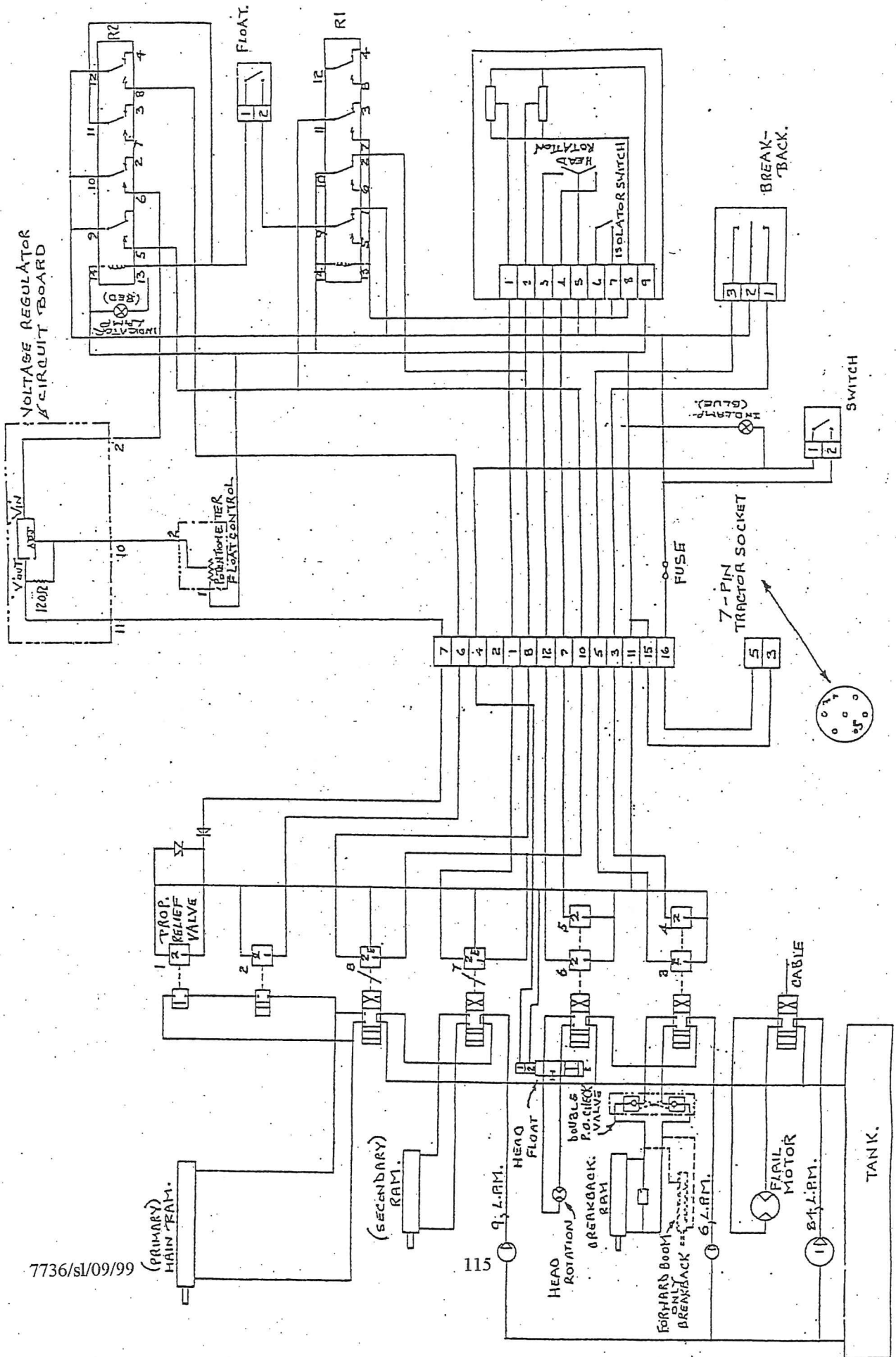

66/6018/9617

## HOSE CONNECTION POINTS

(ELECTRIC HEDGETRIMMER)

<u>CONN REF.</u>	<u>HOSE REF</u>	<u>PART NO</u>	<u>QTY</u>
A-A DD SECOND-P.O CHECK	1/4" HOSE X 185 90x90 @ 180°	004.398	1
B-B DD SECOND-P.O CHECK	1/4" HOSE X 145 90x90 @ 180°	004.399	1
C- BREAKBACK ROD END	1/4" HOSE X 1170 90 x 90 @ 160°	004.445L	1
D- BREAKBACK ANCHOR END	1/4" HOSE X 1170 90 x 90 @ 160°	004.445L	1
E-E DD-V3 (RETURN)	1/2" HOSE X 250 90 x ST	004.400	1
F-F DANFOSS- DD (RETURN)	1/2" HOSE X 220 90 x 90 @ 90°	004.401	1
G-G LINK, ON/OFF - PROP	1/4" HOSE X 180 90 x 90xInline	004.402	1
H-H DANFOSS - ON/OFF	1/4" HOSE X 205 90 x 90 @ 280°	004.403	1
J - SECOND RAM ANCHOR	1/4" HOSE X 1200 90 x 90 @ 90°	004.423	1
K-K DANFOSS - PROP	1/4" HOSE X 315 90 x 90	004.404	1
L-L FIRST RAM ROD END	1/4" HOSE X 550 90 x ST	004.426	1
M-M FIRST RAM ANCHOR END	1/4" HOSE X 700 ST x ST	004.425	1
N - SECOND RAM ROD END	1/4" HOSE X 1250 90 x ST	004.422	1
Q - V3 VALVE TO TANK	1" HOSE X 460 90 x ST	004.420	1
R - PRESSURE	3/4" HOSE X 1230 90x90 @ 225°	004.405L	1
S - PRESSURE (2ND PUMP)	1/2" HOSE X 700 ST x 90	004.364	1
V - PRESSURE LINK PIPE	1/2" HOSE X 290 90 x ST		1
W-W FIRST RAM (ROD END)	1/4" HOSE X 450 ST x 90	004.440	1
	TEE ON 7706		
X-X, D-D RET/FLOAT VALVE	1/4" HOSE X 250 ST x 90	004.381	1
Y-Y LINK PIPE	1/4" HOSE X 75 ST x ST	004.439	1
Z-Z LINK PIPE	1/4" HOSE X 75 ST x ST	004.439	1
	38 BORE SUCTION HOSE x 1100	8000	1
	3/4" HOSE X 540 90 x ST		
	1ST PUMP - 2ND PUMP SECTION	004.564	1



460, 520, 580, -TRIMMERS

(REF. VALVE 'A')

PORTS ① and ② FITTINGS TO BE CHANGED OVER FOR R.H.MACHINES.

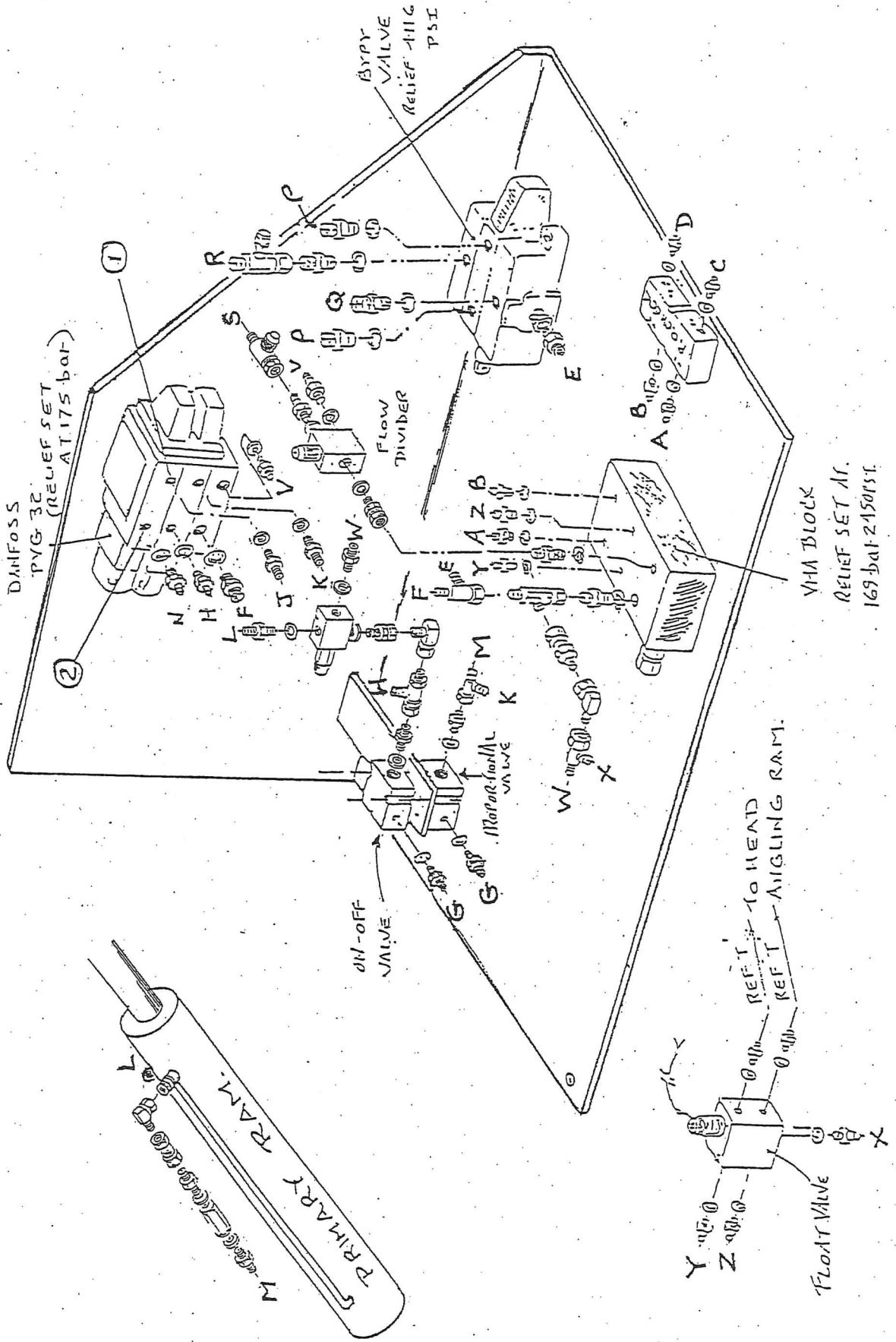

NOTE:-

Hose 004.444 1/4"90 x 90 x 340 @90 is used on all electric machines to connect the Breakback ram to the relief block.

NOTE:-

Electric Hedgetrimmer hoses from:

P - To rotor feed and

T - Head angling

vary from model type to model type, - and are sized and numbered as follows:

520 RIEP (STD HEAD)	P - ROTOR FEED T - HEAD ANGLING T - HEAD ANGLING	3/4" HOSE x 5750 90 x ST 1/4" HOSE x 5650 90 x ST 1/4" HOSE x 5270 90 x ST	004.417 004.436 004.435	2 1 1
460 RIEP (STD HEAD)	P - ROTOR FEED T - HEAD ANGLING	3/4" HOSE x 5170 90 x ST 1/4" HOSE x 4900 90 x ST	004.324 004.414	2 2
520 RIEP (NEW DS HEAD)	P - ROTOR FEED T - HEAD ANGLING	3/4" HOSE x 6400 ST x ST 1/4" HOSE x 5650 90 x ST	004.432 004.436	2 2
460 RIEP (NEW DS HEAD)	P - ROTOR FEED T - HEAD ANGLING	3/4" HOSE x 5820 ST x ST 1/4" HOSE x 4800 90 x ST	1004.431 004.434	2 2
580RIEP (NEW DS HEAD)	P - ROTOR FEED T - HEAD ANGLING	3/4" HOSE x 6400 ST x ST 1/4" HOSE x 5400 90 x ST	004.432 004.379	2 2

NOTE:- FOR NEW TYPE DS HEAD THE 2 OFF  
004.421 HOSES NOT REQUIRED

## SET OF HOSES FOR 580RIEP

<u>COMPONENT ITEM</u>	<u>DESCRIPTION</u>	<u>QTY PER</u>
004.364	Hose 1/2 ST x 90 x 700 --- 2nd pump- Danfoss	1
004.400	Hose 1/2 ST x 90 x 250 --- BYP - Danfoss	1
004.401	Hose 1/2 90 x 90 x 220 --- Return danfoss - V3	1
004.405	Hose 3/4 ST x 90 x 1230 --- 1 <sup>st</sup> pump - V3	1
004.469E	Hose 1/2 90 x 90 x 280 @010 --- Int BYP - Danfoss pressure	1
004.475	Hose 1/4 90 x 90 x 1400 @000 --- B/Back rod - B1	1
004.512	Hose 1/2 ST x 90 x 450 --- Return Inter to V3	1
004.515	Hose 1/4 ST x ST x 240 --- Int E2 - Danfoss top	1
004.533	Hose 1/4 90 x 90 x 1000 @270 --- 2 <sup>nd</sup> ram anchor - Danfoss top	1
004.564	Hose 3/4 ST x 90 x 540 --- 2 <sup>nd</sup> pump suction	1
004.802	Hose 1/4 90 x 90 x 210 @090 --- D2 - Danfoss bottom	1
004.803	Hose 1/4 90 x 90 x 500 --- 1 <sup>st</sup> ram rod - E1	1
004.803	Hose 1/4 90 x 90 x 500 --- 1st ram anchor - D1	1
004.804	Hose 1/4 90 x 90 x 1300 @270 --- 2 <sup>nd</sup> ram rod - Danfoss bottom	1
004.805	Hose 1/4 ST x 90 x 910 --- B/Back anchor - B2	1
004.806	Hose 1 ST x 90 x 580 --- V3 (return) - filter	1
004.517	Hose 1/4 ST x 90 x 6070 --- Head angle	2
004.518	Hose 3/4 ST x ST x 7500 --- V3 - Motor	2
8000	Hose Suction 38mm id	0.53MT

## SET OF HOSES FOR 580RIEL

<u>COMPONENT ITEM</u>	<u>DESCRIPTION</u>	<u>QTY PER</u>
004.364	Hose 1/2 ST x 90 x 700 --- 2nd Pump-> Hy-Pro	1
004.405	Hose 3/4 90 x 90 x 1230 --- 1st Pump - V3	1
004.420	Hose 1 ST x 90 x 460 --- Mo Spool-> Ret Filter	1
004.422	Hose 1/4 ST x 90 x 125 --- Hy-pro - 2nd ram rod	1
004.423	Hose 1/4 90 x 90 x 1200 @090 --- Hy-pro - 2nd ram anchor	1
004.425	Hose 1/4 ST x ST x 700 --- Hy-Pro-> 1st Ram Rod	1
004.426	Hose 1/4 ST x 90 x 550 --- Hy-Pro-> 1st Ram Anch	1
004.445	Hose 1/4 90 x 90 x 1170 --- BB Relief-> Hy-Pro	2
004.517	Hose 1/4 ST x 90 x 6070 --- Head angle	2
004.518	Hose 3/4 ST x ST x 7500 --- Motor	2
004.572	Hose 3/4 ST x 90 x 420 --- 2nd Pump Suction	1
004.654	Hose 1/4 90 x 90 x 1570 @160 --- B/B rod - Hy-pro top	1
8000	Hose Suction 38mm id --- Suction line	0.55MT

460, 500, 520, - INCHES

(REF. VALVE 'A')

PORTS ① & ② FITTINGS TO BE CHANGED OVER FOR R.H. MACHINES.

7736/s/09/99

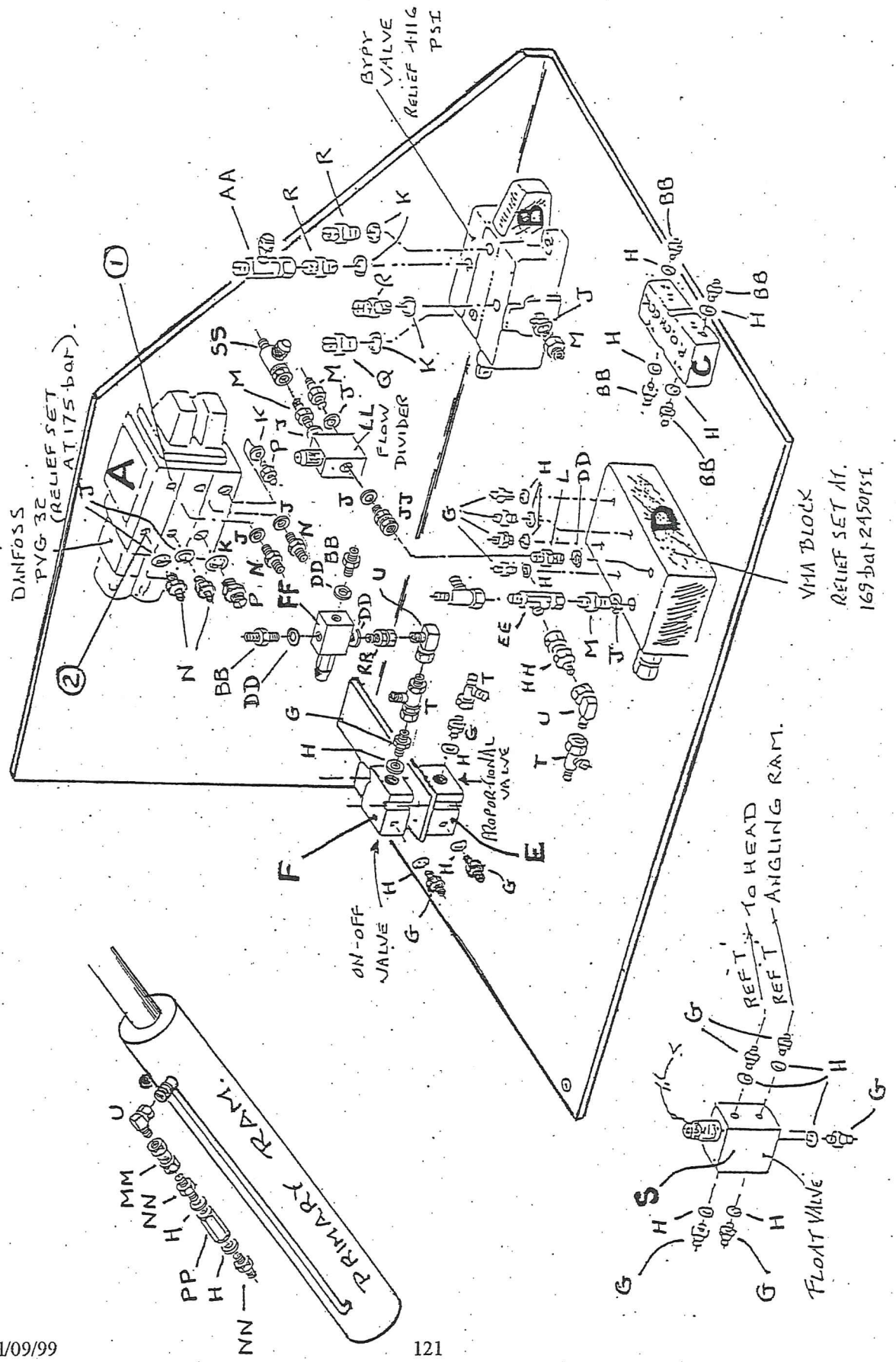



ELECTRIC HEDGETRIMMER -  
VALVES AND COMPONENTS

<u>ITEM</u>	<u>PART NO</u>	<u>DESCRIPTION</u>	<u>QTY</u>
A	7577	DANFOSS PROPORTIONAL VALVE	1
*	2793	SETSCREW M8 X 20 (8.8)	4
*	3001	WASHER M8 SPRING	4
B	7542	MOTOR SPOOL VALVE	1
*	3183	BOLT M8 X 45 (8.8)	3
*	3111	WASHER M8 (FORM A)	3
*	3182	STIFFNUT M8 NYLOC	3
C	7716	DOUBLE P.O CHECK VALVE	1
*	6981	BOLT M6 X 50 (8.8)	2
*	4776	NUT M6 NYLOC	2
D	7706	'VMA' MANIFOLD BLOCK	1
	*INCLUDES 7580	RELIEF CARTRIDGE SET AT 125 BAR	
*	2793	SETSCREW M8 X 20 (8.8)	2
*	3001	WASHER M8 SPRING	2
E	7583	PROPORTIONAL RELIEF VALVE	1
F	7584	ON.OFF VALVE	1
*	184.408	M6 STUDDING X 100 LONG	2
*	4776	NUT M6 NYLOC	4
*	1360	WASHER M6 FLAT	4
G	1823	ADAPTOR 1/4" BSP X 1/4" BSP	13
H	1181	SEAL 1/4" BSP	19
J	0909	SEAL 1/2" BSP	9
K	0934	SEAL 3/4" BSP	6
L	0665	ADAPTOR 3/8" BSP X 3/8" BSP	1





ELECTRIC HEDGETRIMMER -  
VALVES AND COMPONENTS  
CONTINUED

<u>ITEM</u>	<u>PART NO</u>	<u>DESCRIPTION</u>	<u>QTY</u>
M	1826	ADAPTOR 1/2" BSP X 1/2" BSP	4
N	1825	ADAPTOR 1/2" BSP X 1/4" BSP	4
p	1834	ADAPTOR 1/2" BSP X 3/4" BSP	2
Q	1836	ADAPTOR 3/4" BSP X 1" BSP	1
R	0935	ADAPTOR 3/4" BSP X 3/4" BSP	3
S	7859	FLOAT VALVE	1
T	7323	TEE 1/4" BSP FM/M/M	4
U	6948	ADAPTOR 90o 1/4" BSP M/FM	3
AA	7810	PRESSURE TEST FITTING 3/4" BSP	1
BB	1180	ADAPTOR 3/8" BSP X 1/4" BSP	6
CC	184.407	VALVE MOUNTING PANEL	1
*	2987	SETSCREW M8 X 25 (8.8) (PLATE TO TANK)	3
DD	0670	SEAL 3/8" BSP	4
*	184.410	BRACKET FOR JUNCTION BOX	1
*	3731	SETSCREW M8 X 16 (8.8)	2
EE	5002	TEE 1/2" BSP FM/M/M	1
FF	4135 (R400)	RELIEF VALVE (R27 BAR) 400 PSI	1
HH	7833	ADAPTOR (IN LINE) 1/4" BSP F/M X 3/8" BSP M	2
JJ	4927	ADAPTOR 1/2" BSP M-FM	1
KK			
LL	7878	FLOW DIVIDER	1
MM	6943	ADAPTOR 1/4" BSP F.FLN	1
NN	1823	ADAPTOR 1/4" BSP X 1/4" BSP	2
PP	7813	RESTRICTOR (1 WAY) 1.8 (0.5 BAR)	1
RR	7833	ADAPTOR 1/4 FM X 3/8 MALE	1
SS	7811	PRESSURE TEST FITTING 1/2" B.S.P	1

NOTE:- SYSTEM PRESSURE AT TEST POINT 'A-A'  
= (2500 P.S.I) (170 BAR)

## FAULT FINDING CHART

BREAKBACK RAM NOT OPERATIVE	CHECK FOR 12V ON PLUGS 3 & 4	<p>FAULTY HYDRAULIC VALVE</p> <hr/> <p>— FAULTY WIRING OR SWITCH</p>
BREAKBACK GIVES TO EASILY	RESET RELIEF VALVE ON RAM (SHOULD BE SET TO 2000 P.S.I)(136 BAR)	
NO HEAD ROTATION	CHECK FOR 12V ON PLUGS 5 & 6	<p>FAULTY HYDRAULIC VALVE</p> <hr/> <p>FAULTY WIRING OR DANFOSS SWITCH</p>
SLOW HEAD ROTATION OR <360°	RELIEF VALVE NEEDS RE-SETTING (SHOULD BE SET TO 2250PSI) (153 BAR)	
SECOND RAM INOPERATIVE	CHECK FOR 12V ON PIN 1 AND 3-9V ON PIN 2 OF PLUG 7	<p>FAULTY HYDRAULIC VALVE</p> <hr/> <p>FAULTY WIRING OR DANFOSS CONTROL HANDLE</p>
MAIN RAM INOPERATIVE	CHECK FOR 12V ON PIN 1 AND 3-9V ON PIN 2 OF PLUG 8	<p>FAULTY HYDRAULIC VALVE</p> <hr/> <p>FAULTY WIRING OR DANFOSS CONTROL HANDLE</p>
	FLOAT ON/OFF VALVE STUCK IN OPEN POSITION - SEE FLOAT SYSTEM	

## FAULT FINDING CHART CONTINUED

NO FLOAT LAMP ON	<p>IS HYDRAULIC ON/OFF VALVE 2 OPERATING.</p> <hr/> <p>IF MACHINE AND TRACTOR SETTLE WHEN FLOAT SWITCH IS OPERATED THEN THIS VALVE IS WORKING</p> <hr/> <p>PROPORTIONAL RELIEF VALVE NOT WORKING - CHECK VOLTAGE ON PLUG 1. SHOULD RANGE FROM 0V TO 9V AS FLOAT CONTROL KNOB IS TUNED</p>	<p>FAULTY PROPORTIONAL RELIEF VALVE</p> <hr/> <p>CHECK 12V ON PLUG 2</p> <hr/> <p>CHECK OUTPUT ON TERMINAL 11 ON VOLTAGE REGULATOR BOARD. (SHOULD BE 0V TO 9V)</p> <hr/>	<p>FAULTY HYDRAULIC VALVE</p> <hr/> <p>FAULTY WIRING</p> <hr/> <p>FAULTY WIRING</p> <hr/> <p>FAULTY BOARD OR POTENTIOMETER</p>
NO FLOAT LAMP OPER- ATE	<p>DANFOSS VALVE NOT OPERATING CHECK FOR 12V ON PLUG 8</p> <hr/> <p>NOTE:- THIS VALVE CAN BE VISUALLY CHECKED BY FITTING AN OPERATING LEVER &amp; "MANUAL OPERATE" LOOKING FOR MOVEMENT.</p>	<p>FAULTY VALVE</p> <hr/> <p>FAULTY WIRING</p>	
	<p>FLOAT SWITCH FAULTY</p>		

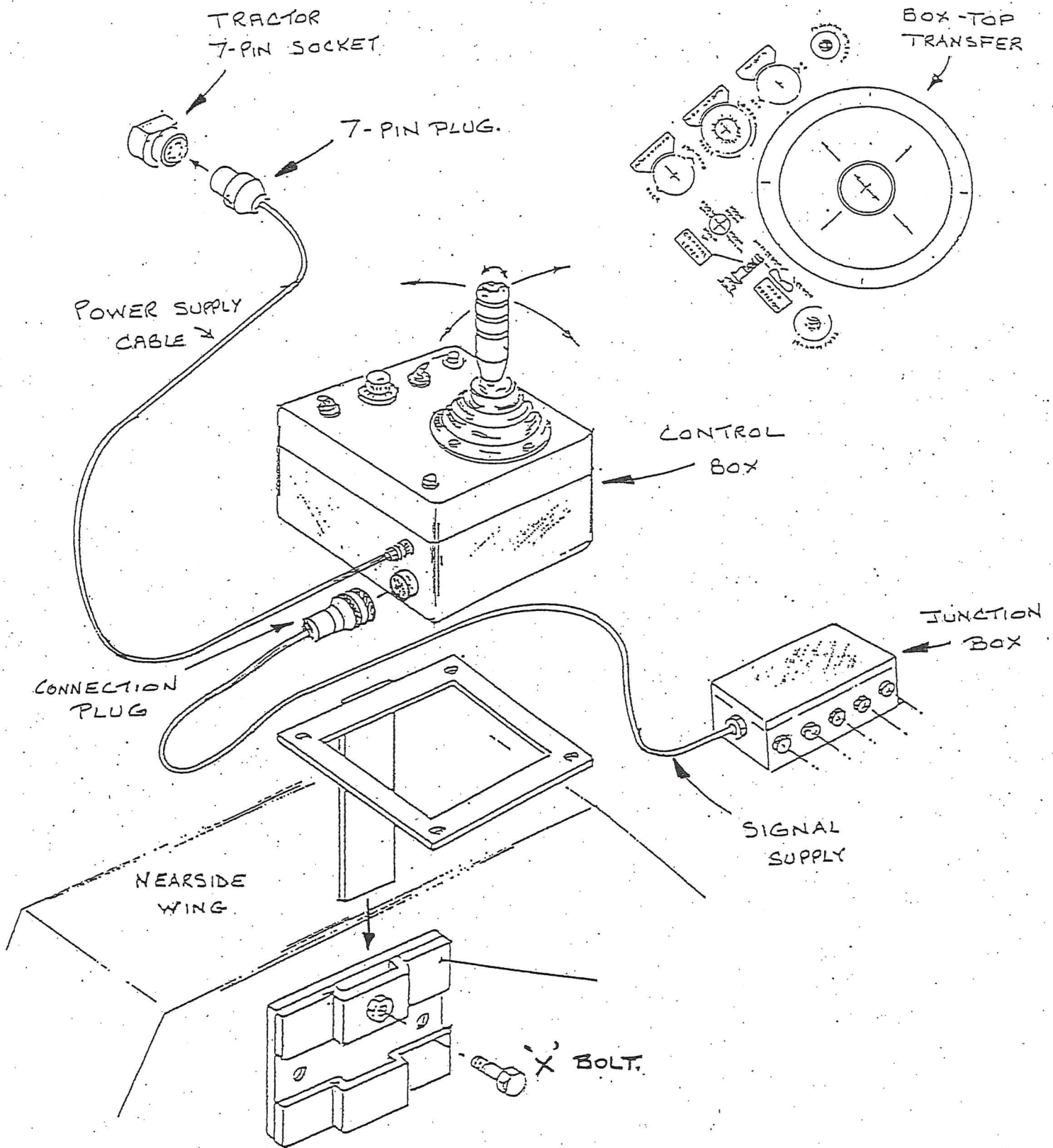

## ELECTRIC MACHINE - CONTROL COMPONENTS

<u>ITEM</u>	<u>PART NO</u>	<u>DESCRIPTION</u>	<u>QTY</u>
	184.660	Wiring Harness (Mch Side)	1
	184.201	Control Box (Tractor Side)	1



LEFT HAND MACHINE AS DRAWN

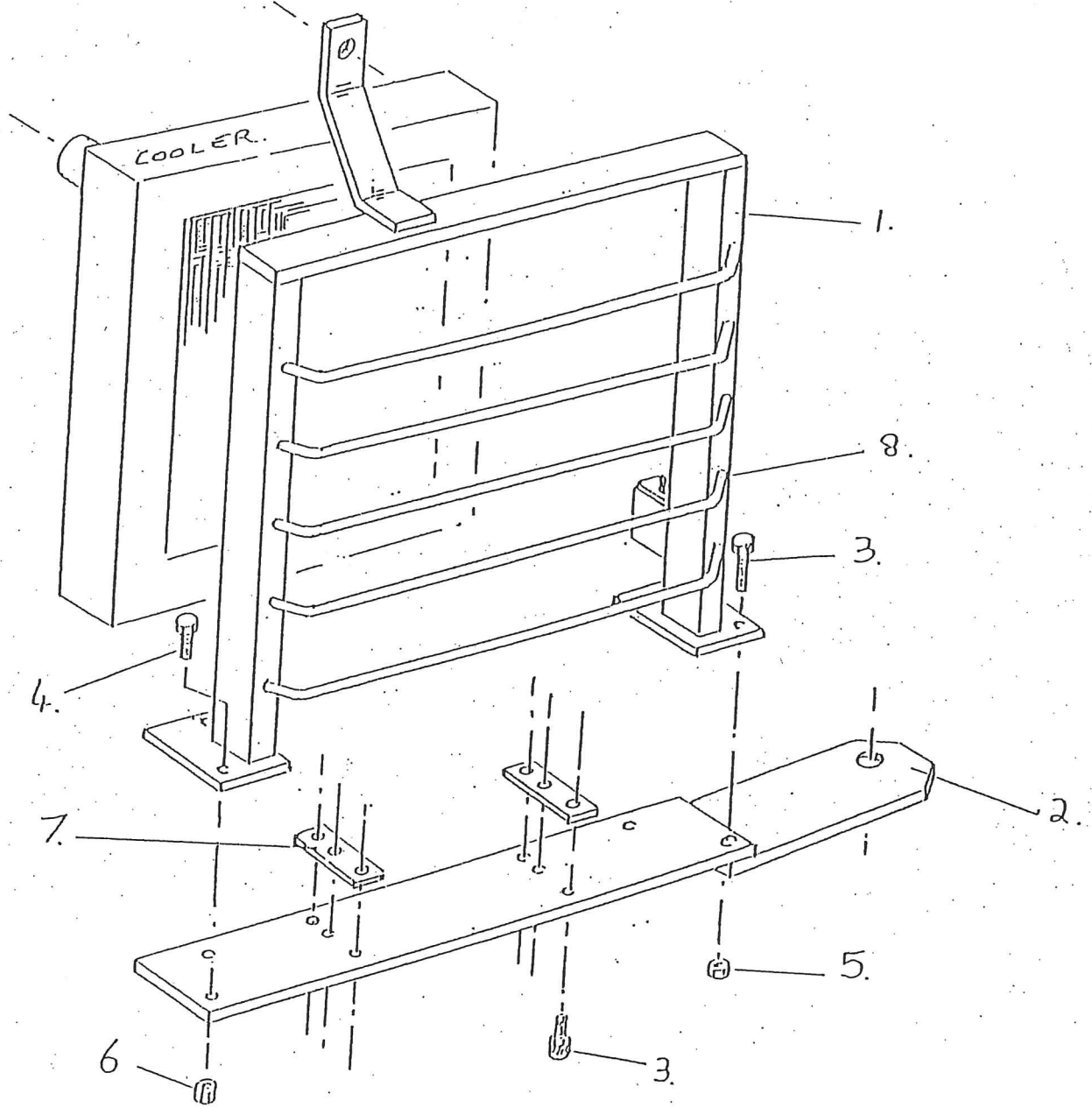

COOLER, MOUNTING FRAME AND GUARD  
LEFT HAND MACHINE ONLY

<u>ITEM</u>	<u>PART NO</u>	<u>DESCRIPTION</u>	<u>QTY</u>
1	184.593 L/R	Cooler Guard (Large)	1-L or L-R
2	184.592 L/R	Base Plate - (Cooler and Guard)	1-L or L-R
3	3110	Setscrew M8 x 30	7
4	2987	Setscrew M8 x 25	3
5	3182	Stiffnut M8 Nyloc	2
6	3182	Stiffnut M8 Nyloc	2
7	186.153	Spacer Plate (Cooler)	2
8	7949	Switch for cooler (RS-317-847 DPDT Ctre Off)	1
*	2962	Setscrew M12 x 35 8.8	1-R/H only
*	2729	Spring Washer M12	1-R/H only
*	2716	Flatwasher M12 (for 184.593R - (anchor to main pin))	1-R/H only

TWOSE

MC

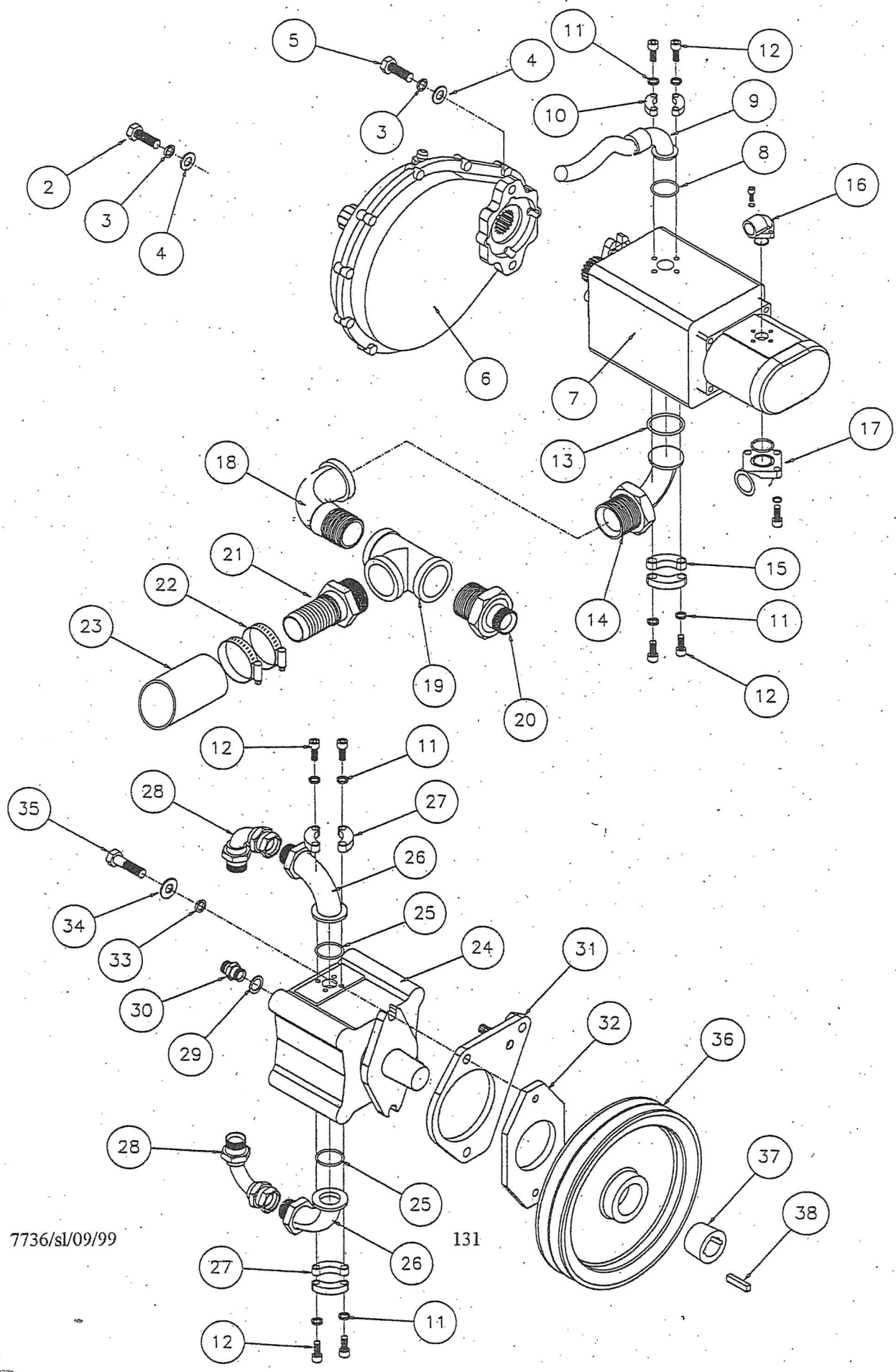

7736/sl/09/99

131

PUMP AND MOTOR ASSEMBLY FOR  
POWER PACK 2 68HP (STD ON 526 AND 637) CONTINUED

<u>ITEM</u>	<u>PART NO</u>	<u>DESCRIPTION</u>	<u>QTY</u>
2	2962	Setscrew M12 * 35 (8.8)	4
3	2729	Washer M12 Spring	6
4	3192	Washer M12 Form C	6
5	2748	Setscrew M12 * 40 (8.8)	2
6	184.628	Gearbox 1:3.6	1
7	8098(52,19)	Pumps Dual	1
8	7987.2	O Ring 3/4"	1
9	004.702	Hose 3/4 90 x FL x 2340 @ 100	1
10	7987.1	Hose 3/4" Split Flange	2
11	2728	Washer M10 Spring	16
12	4234	Setscrew M10 * 30 Sock	16
13	7988.2	O Ring 1"	1
14	184.596	Adaptor Swaged Flange - 1 1/4"	1
15	7988.1	Hose 1" Split Flange	2
16	7552	Elbow 1/2" T30/13.5 c/w O Ring + M6 Screws	1
17	7553	Elbow 3/4" T40/20 c/w O ring + M8 Screws	1
18	8002	Adaptor 1 1/2" M-F BSPT	2
19	8001	Tee 1 1/2" F-F-F (BSPT)	1
20	8010	Adaptor 3/4 bsp x 1 1/4"	1
21	7999	Hose Tail 1 1/2" BSPT	1
22	7455	Clip Jubilee	4
23	8000	Suction Hose	
24	7975	Motor	1
25	7989.2	O Ring 1 1/4"	2
26	188.062	Hose 1" Swaged Flange	2
27	7989.1	Hose 1 1/4 Swaged Flange	4
28	3400	Adaptor 3/4 bsp Swept 90	2
29	0665	Adaptor 3/8 bsp	1
30	0670	Seal 3/8 Dowty bonded	1
31	186.135	Motor Plate WA	1
32	186.136	Motor Fixing Ring	1
33	2729	Washer M12 Spring	2
34	3192	Washer M12 Form C	2
35	2700	Bolt M12 * 45	2
36	188.061	Pulley Motor 242 PCD	1
37	7990.2	Taper lock 1" bore 1210	1
38	7720	Key (Taper lock to pulley)	1
*	7692	Drive belts	2
*	184.531	Motor Adjuster	1
*	2721	Fullnut M12 (to 184.531)	2
*	3192	Washer M12 (form C) (to 184.531)	2
*	3082	Stiffnut M12 Nyloc (to 184.531)	1

460 520 AND 580 TRIMMERS  
WITH OIL COOLER - 65 H.P.  
AT CUTTER.

(REF. VALVE 'A')

PORTS ① & ② FITTINGS TO BE  
 CHANGED OVER FOR R.H. MACHINES.

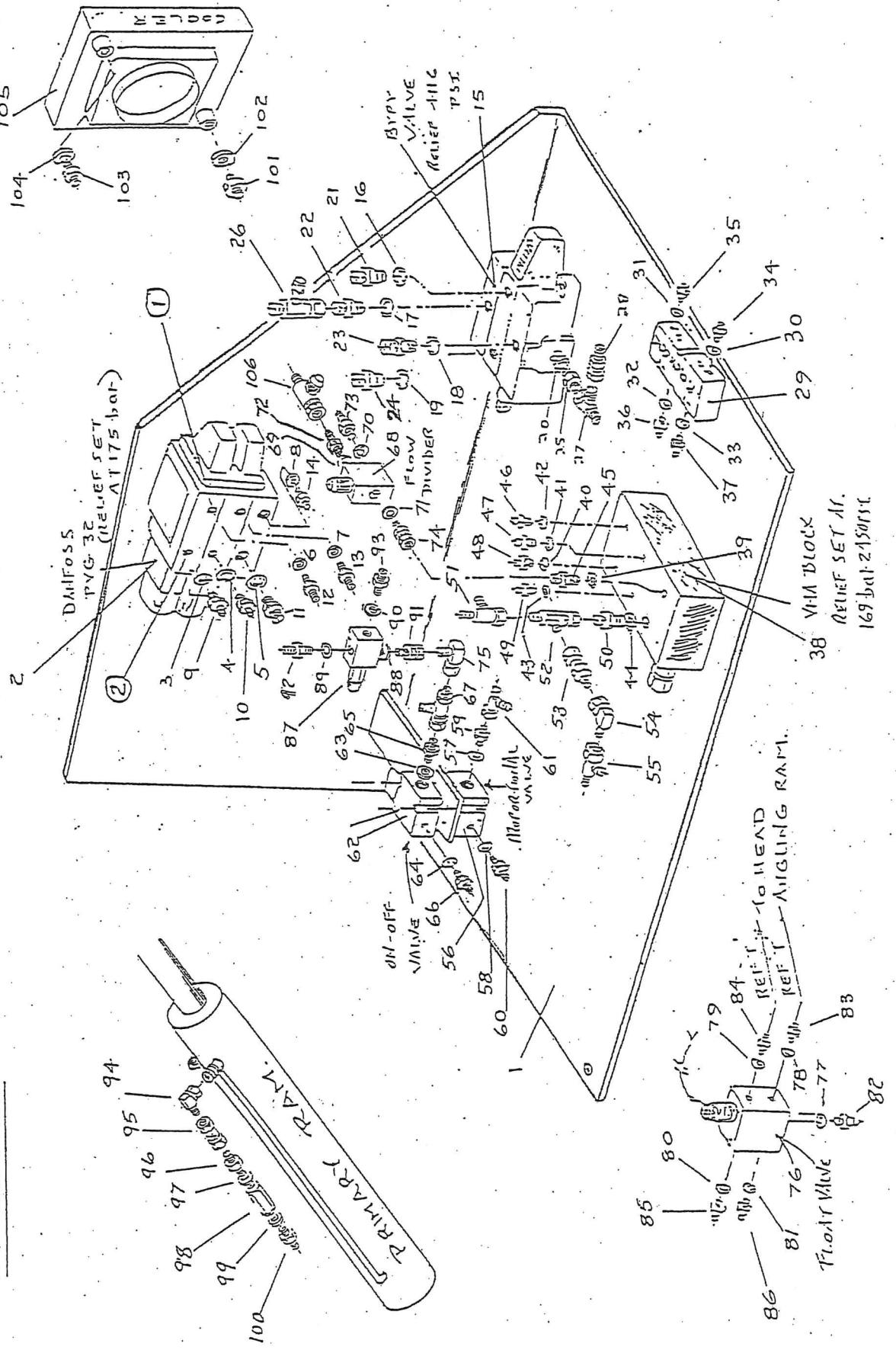



## HYDRAULIC FITTINGS

<u>ITEM</u>	<u>PART NO</u>	<u>DESCRIPTION</u>	<u>QTY</u>
1	184.407	Valve mounting panel	1
*	2987	Setscrew M8 x 25 (plate to tank)	3
2	7577	Danfoss Proportional Valve	1
*	2793	Setscrew M8 x 20	4
*	3001	Washer M8 Spring	4
3	0909	Seal 1/2" BSP	1
4	0909	Seal 1/2" BSP	1
5	0934	Seal 3/4" BSP	1
6	0909	Seal 1/2" BSP	1
7	0909	Seal 1/2" BSP	1
8	0934	Seal 3/4" BSP	1
9	1825	Adaptor 1/2" BSP x 1/4" BSP	1
10	1825	Adaptor 1/2" BSP x 1/4" BSP	1
11	1834	Adaptor 1/2" BSP x 3/4" BSP	1
12	1825	Adaptor 1/2" BSP x 1/4" BSP	1
13	1825	Adaptor 1/2" BSP x 1/4" BSP	1
14	1834	Adaptor 1/2" BSP x 3/4" BSP	1
15	7967	Valve block	
*	7090	Setscrew M10 x 100	3
*	4421	Stiffnut M10	3
*	144.065	Spacer	3
16	0934	Seal 3/4" BSP	1
17	0934	Seal 3/4" BSP	1
18	1934	Seal 1" BSP	1
19	0934	Seal 3/4" BSP	1
20	1934	Seal 1" BSP	1
21	0935	Adaptor 3/4" BSP x 3/4" BSP	1
22	0935	Adaptor 3/4" BSP x 3/4" BSP	1
23	2450	Adaptor 1" BSP x 1" BSP	1
24	0935	Adaptor 3/4" BSP x 3/4" BSP	1
25	5243	Adaptor 1" BSP x 1/2" BSP	1
26	7810	Pressure Test fitting 3/4" BSP	1
27	5002	Tee 1/2" BSP FM/M/M	
28	7856	Adaptor 3/8 x 1/2 M/FLN	1
29	7716	Double PO check valve	1
*	6981	Bolt M6 x 50	2
*	3182	Nut M8 Nyloc	2



460 520 AND 580 TRIMMERS  
WITH OIL COOLER - 65 H.P.  
AT CUTTER.

(REF. VALVE 'A')

PORTS ① & ② FITTINGS TO BE  
 CHANGED OVER FOR R.H. MACHINES.

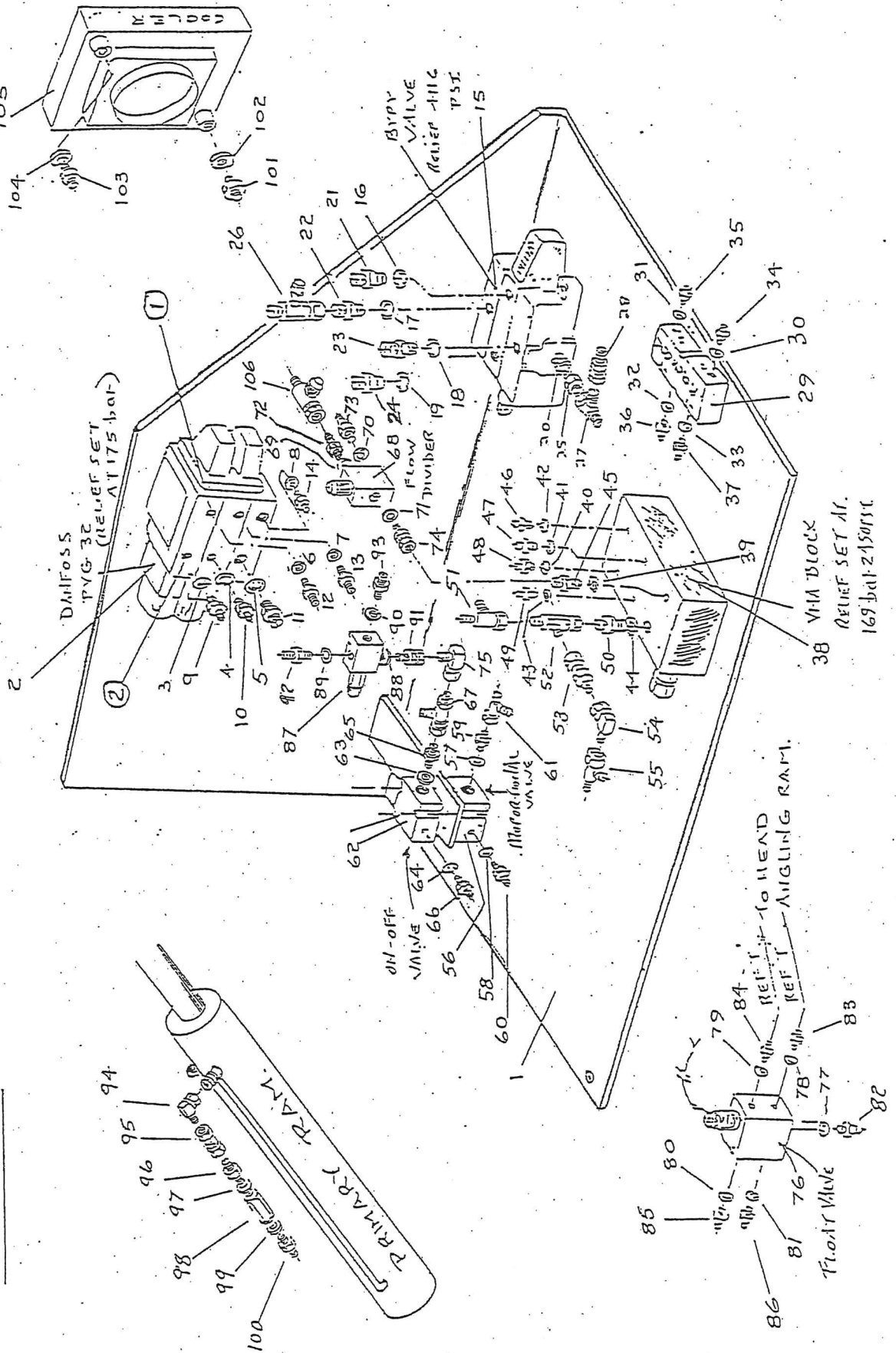

## HYDRAULIC FITTINGS CONTINUED

<u>ITEM</u>	<u>PART NO</u>	<u>DESCRIPTION</u>	<u>QTY</u>
30	1181	Seal 1/4" BSP	1
31	1181	Seal 1/4" BSP	1
32	1181	Seal 1/4" BSP	1
33	1181	Seal 1/4" BSP	1
34	1180	Adaptor 3/8" BSP x 1/4" BSP	1
35	1180	Adaptor 3/8" BSP x 1/4" BSP	1
36	1180	Adaptor 3/8" BSP x 1/4" BSP	1
37	1180	Adaptor 3/8" BSP x 1/4" BSP	1
38	7706	VMA manifold block	1
*	includes 7580 Relief cartridge set at 169 bar		
39	0670	Seal 3/8" BSP	1
40	1181	Seal 1/4" BSP	1
41	1181	Seal 1/4" BSP	1
42	1181	Seal 1/4" BSP	1
43	1181	Seal 1/4" BSP	1
44	0909	Seal 1/2" BSP	1
45	0665	Adaptor 3/8" BSP x 3/8" BSP	1
46	1823	Adaptor 1/4" BSP x 1/6" BSP	1
47	1823	Adaptor 1/4" BSP x 1/6" BSP	1
48	1823	Adaptor 1/4" BSP x 1/6" BSP	1
49	1823	Adaptor 1/4" BSP x 1/6" BSP	1
50	1826	Adaptor 1/2" BSP x 1/2" BSP	1
51	7323	Tee 1/4" BSP FM/M/M	1
52	5002	Tee 1/2" BSP FM/M/M	1
53	7833	Adaptor 1/4" FLN BSP X 3/8" M BSP	1
54	6948	Adaptor 1/4" BSP M-FLN 91	1
55	7323	Tee 1/4" BSP FM/M/M	1
56	7583	Proportional Relief Valve	1
57	1181	Seal 1/4" BSP	1
58	1181	Seal 1/4" BSP	1
59	1823	Adaptor 1/4" BSP X 1/4" BSP	1
60	1823	Adaptor 1/4" BSP x 1/4" BSP	1
61	7323	Tee 1/4" BSP FM/M/M	1
62	7584	ON/OFF valve	1
*	184.408	M6 studding x 100 long	2
*	4776	Nut M6 Nyloc	4
*	1360	Washer M6 Flat	4
63	1181	Seal 1/4" BSP	1
64	1181	Seal 1/4" BSP	1



## HYDRAULIC FITTINGS CONTINUED

<u>ITEM</u>	<u>PART NO</u>	<u>DESCRIPTION</u>	<u>QTY</u>
65	1823	Adaptor 1/4" BSP x 1/4" BSP	1
66	1823	Adaptor 1/4" BSP x 1/4" BSP	1
67	7323	Tee 1/4" BSP FM/M/M	1
68	7878	Flow Divider	1
69	0909	Seal 1/2" BSP	1
70	0909	Seal 1/2" BSP	1
71	0909	Seal 1/2" BSP	1
72	1826	Adaptor 1/2" BSP x 1/2" BSP	1
73	1826	Adaptor 1/2" BSP x 1/2" BSP	1
74	4927	Adaptor 1/2" BSPM/FM	1
75	6948	Adaptor 90° 1/4" BSPM/FM	1
76	7859	Float Valve	1
77	1181	Seal 1/4" BSP	1
78	1181	Seal 1/4" BSP	1
79	1181	Seal 1/4" BSP	1
80	1181	Seal 1/4" BSP	1
81	1181	Seal 1/4" BSP	1
82	1823	Adaptor 1/4" BSP x 1/4" BSP	1
83	1823	Adaptor 1/4" BSP x 1/4" BSP	1
84	1823	Adaptor 1/4" BSP x 1/4" BSP	1
85	1823	Adaptor 1/4" BSP x 1/4" BSP	1
86	1823	Adaptor 1/4" BSP x 1/4" BSP	1
87	4135 (R400)	Relief valve (R27 Bar) 400 psi	1
88	0670	Seal 3/8" BSP	1
89	0670	Seal 3/8" BSP	1
90	0670	Seal 3/8" BSP	1
91	7833	Adaptor 1/4" FM x 3/8 Male	1
92	1180	Adaptor 3/8" BSP x 1/4" BSP	1
93	1180	Adaptor 3/8" BSP x 1/4" BSP	1
94	6948	Adaptor 1/4" BSP M-FLN 91	1
95	6943	Adaptor 1/4" BSP F-FLN	1
96	1823	Adpator 1/4" BSP x 1/4" BSP	1
97	1181	Seal 1/4" BSP	1
98	7813	Restrictor (1 way) 1.8 (0.5 bar)	1
99	1181	Seal 1/4" BSP	1
100	1823	Adaptor 1/4" x 1/4" BSP	1
101	2450	Adaptor 1" BSP x 1" BSP	1
102	1934	Seal 1" BSP	1
103	2450	Adaptor 1" BSP x 1" BSP	1
104	1934	Seal 1" BSP	1
105	7950	Cooler-Fan c/w Fan guard	1
106	7811	Pressure test fitting 1/2" B.S.P	1

460 520 AND 580 TRIMMERS  
WITH OIL COOLER - 65 H.P.  
AT CUTTER.

(REF. VALVE 'A')  
 PORTS ① & ② FITTINGS TO BE  
 CHANGED OVER FOR R.H. MACHINES.

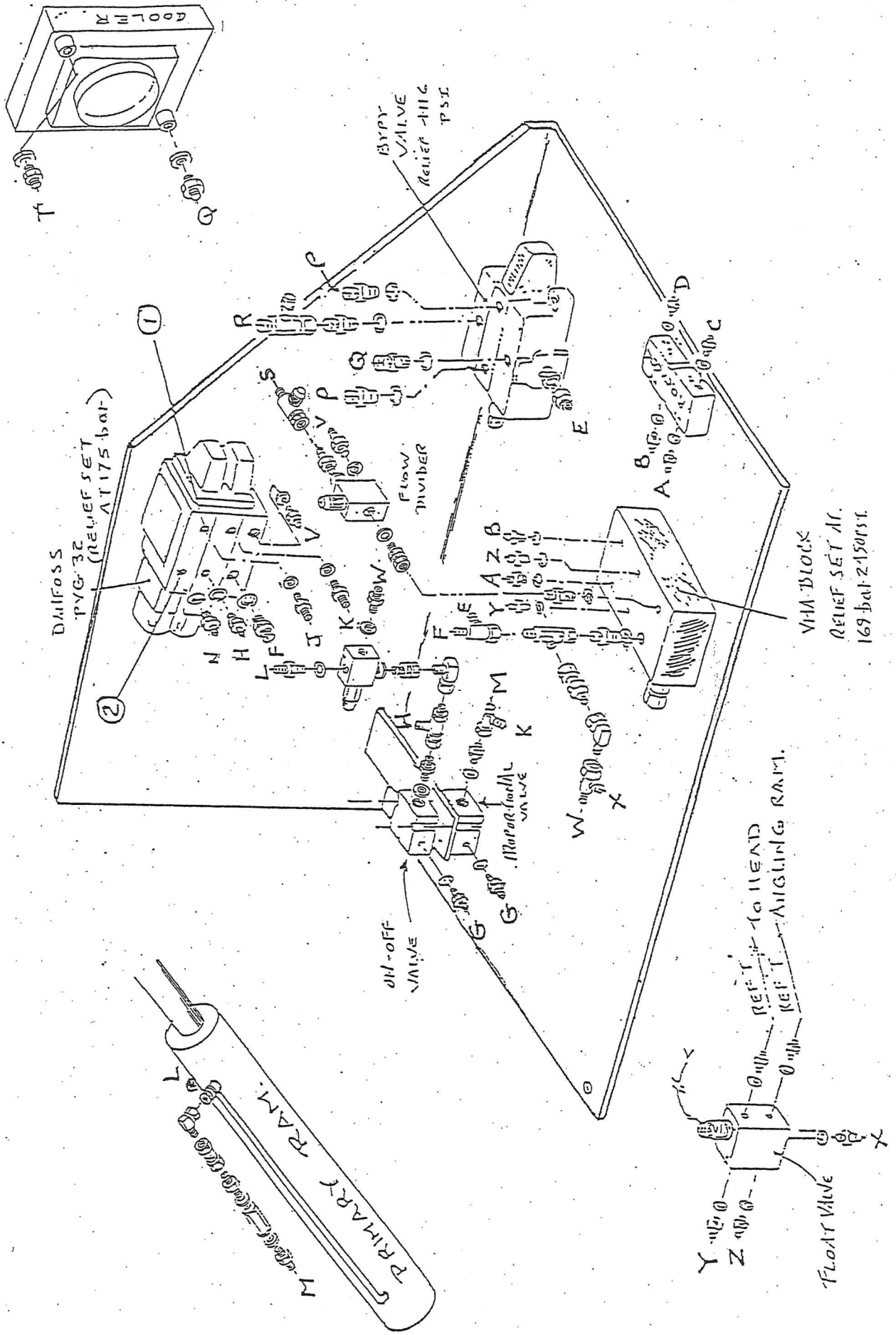



HOSE CONNECTION POINTS  
(ELECTRIC HEDGETRIMMER  
520 WITH COOLER (65HP) @ CUTTER)

<u>CONN REF.</u>	<u>HOSE REF</u>	<u>PART NO</u>	<u>QTY</u>
A-A	1/4" HOSE X 185 90x90 @ 180°	004.398	1
B-B	1/4" HOSE X 145 90x90 @ 180°	004.399	1
C- BREAKBACK ROD END	1/4" HOSE X 1170 90x90 @ 160°	004.445L	1
D- BREAKBACK ANCHOR END	1/4" HOSE X 1170 90x90 @ 160°	004.445L	1
E-E	1/2" HOSE X 250 90xST	004.400	1
F-F	1/2" HOSE X 220 90x90 @ 90°	004.401	1
G-G	1/4" HOSE X 180 90x90xInline	004.402	1
H-H	1/4" HOSE X 205 90x90 @ 280°	004.403	1
J- SECOND RAM ANCHOR	1/4" HOSE X 600 90x90 @ 90°	004.423	1
K-K	1/4" HOSE X 315 90x90	004.404	1
L-L FIRST RAM ROD END	1/4" HOSE X 550 90xST	004.426	1
M-M FIRST RAM ANCHOR END	1/4" HOSE X 900 90xST	004.425	1
N- SECOND RAM ROD END	1/4" HOSE X 1250 90xST	004.422	1
P- MOTOR BLEED	3/8" HOSE X 6600 ST x ST	004.652	
Q- BYPY VALVE TO COOLER	1" HOSE X 430 90 x ST	004.650	1 L/H
or Q- BYPY VALVE TO COOLER	1" HOSE X 560 90 x 90 @ 320°	004.707	1 R/H
R- PRESSURE	3/4" HOSE X 1230 90x90 @ 225°	004.405L	1
S- PRESSURE (2ND PUMP)	1/2" HOSE X 840 STxST	004.651	1
T- COOLER TO FILTER (ON TANK)	1" HOSE X 850 90xST	004.653	1 L/H
or T- COOLER TO FILTER	1" HOSE X 665 90 x 90	004.708	1 R/H
V- PRESSURE LINK PIPE	1/2" HOSE X 250 90 x ST	004.400	1
W-W FIRST RAM (ROD END)	1/4" HOSE X 450 ST x 90 TEE ON 7706	004.440	1
X-X, D-D RET/FLOAT VALVE	1/4" HOSE X 250 ST x 90	004.381	1
Y-Y LINK PIPE	1/4" HOSE X 75 ST x ST	004.439	1
Z-Z LINK PIPE	1/4" HOSE X 75 ST x ST	004.439	1
	1" HOSE X 1080 90xST FIRST RAM SUCTION	004.321	1
	3/4" HOSE X 970 90x90 @ 220° 2ND PUMP SUCTION	004.325L	1
	1/2" HOSE X 330 90xST SUCTION 2ND TO 3RD PUMP	004.331	1
	3/4" HOSE X 325 STxST PIVOT TO MOTOR	004.421	2



4607520 AND 580 HEDGETRIMMER  
 HY-PRO. SOLENOID VALVE  
 FOR HYDRAULIC CONTROL  
 - VIA-ELECTRONIC SWITCHES  
 (RELIEF SET AT 170 bar)

NOTE: VALVE REF = CV1111.  
 TWOSE No =

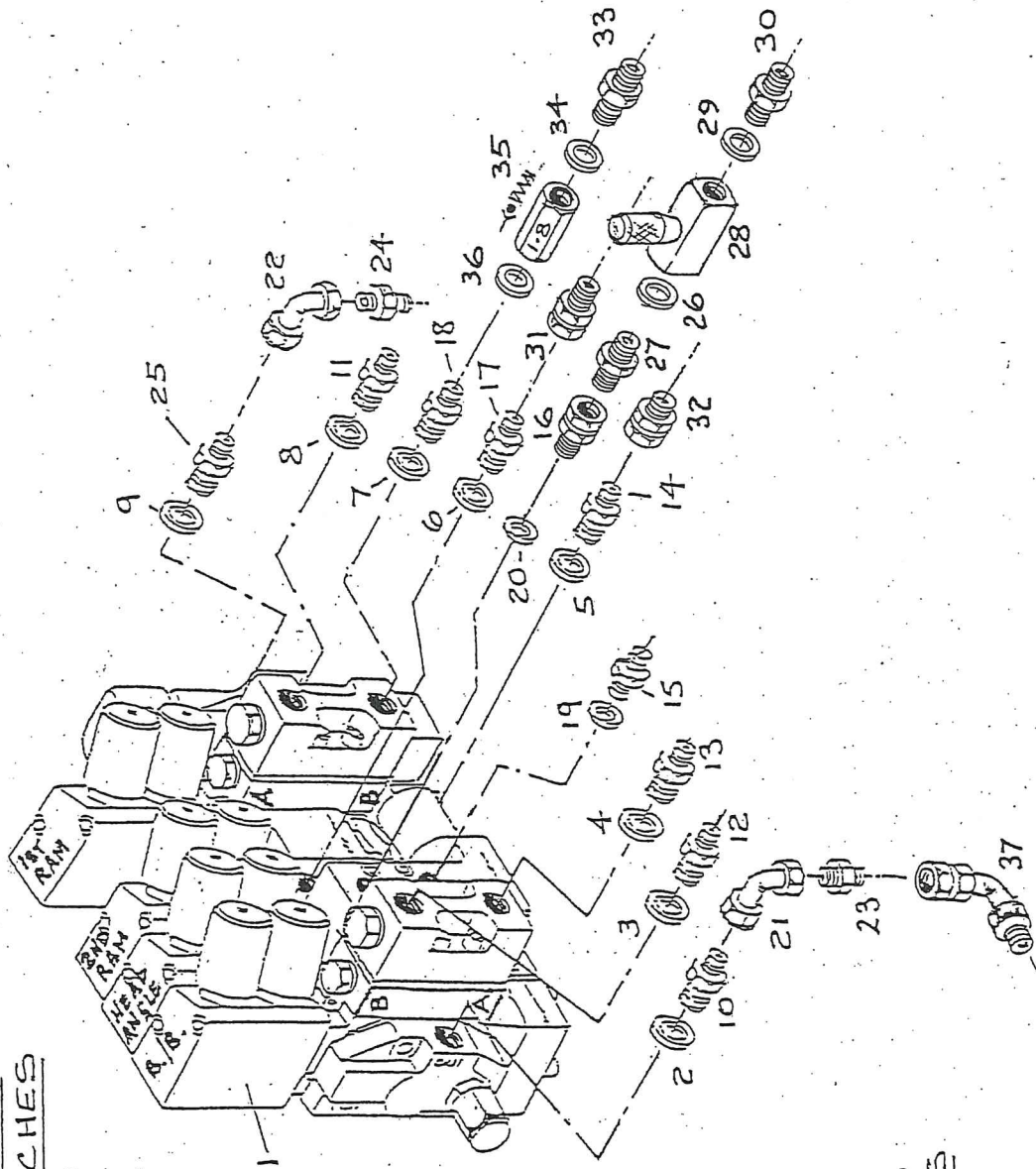

IMPORTANT  
 WITH VALVE FITTED-ALL  
 TOP PORTS MUST BE  
 CONNECTED TO ROD ENDS  
 OF RELEVANT CYLINDERS

460, 520 AND 580 HEDGETRIMMER  
HYDRAULIC VALVE AND FITTINGS  
(ELECTRIC SWITCH CONTROL)

<u>ITEM</u>	<u>PART NO</u>	<u>DESCRIPTION</u>	<u>QTY</u>
1	7944A	Valve block (ref CV1111) R 170 Bar	1
*	7698.4	Relief valve (for valve ) set @ 170 bar.	
2	0670	Seal 3/8" BSP	1
3	0670	Seal 3/8" BSP	1
4	0670	Seal 3/8" BSP	1
5	0670	Seal 3/8" BSP	1
6	0670	Seal 3/8" BSP	1
7	0670	Seal 3/8" BSP	1
8	0670	Seal 3/8" BSP	1
9	0670	Seal 3/8" BSP	1
10	0665	Adaptor 3/8 BSP	1
11	1180	Adaptor 1/4" x 3/8 BSP	1
12	1180	Adaptor 1/4" x 3/8" BSP	1
13	1180	Adaptor 1/4" x 3/8" BSP	1
14	7740	Adaptor 1/4" x 3/8" BSP (1.5 Restricted)	1
15	1823	Adaptor 1/4" BSP	1
16	7305	Adaptor 1/4" BSP M/FM	1
17	1180	Adaptor 1/4 x 3/8 BSP	1
18	1180	Adaptor 1/4 x 3/8 BSP	1
19	1181	Seal 1/4" BSP	1
20	1181	Seal 1/4" BSP	1
21	7819	Adaptor 3/8 BSP FLN/FLN 90°	1
22	7819	Adaptor 3/8" BSP FLN/FLN 90°	1
23	4928	Adaptor 3/8 x 1/2" BSP	1
24	4928	Adaptor 3/8" x 1/2" BSP	1
25	0665	Adaptor 3/8 x 3/8 BSP	1
26	1181	Seal 1/4" BSP	1
27	1823	Adaptor 1/4" BSP	1
28	6953	Valve for flow control	1
29	1181	Seal 1/4" BSP	1
30	1823	Adaptor 1/4" BSP	1
31	7305	Adaptor 1/4" BSP M/FM	1

460, 520 AND 580 HEDGE TRIMMER

HY-PRO. SOLENOID VALVE  
FOR HYDRAULIC CONTROL  
- VINELECTRONIC SWITCHES

(RELIEF SET AT 170 bar)

NOTE:- VALVE REF = CV11111.

TWOSE No =

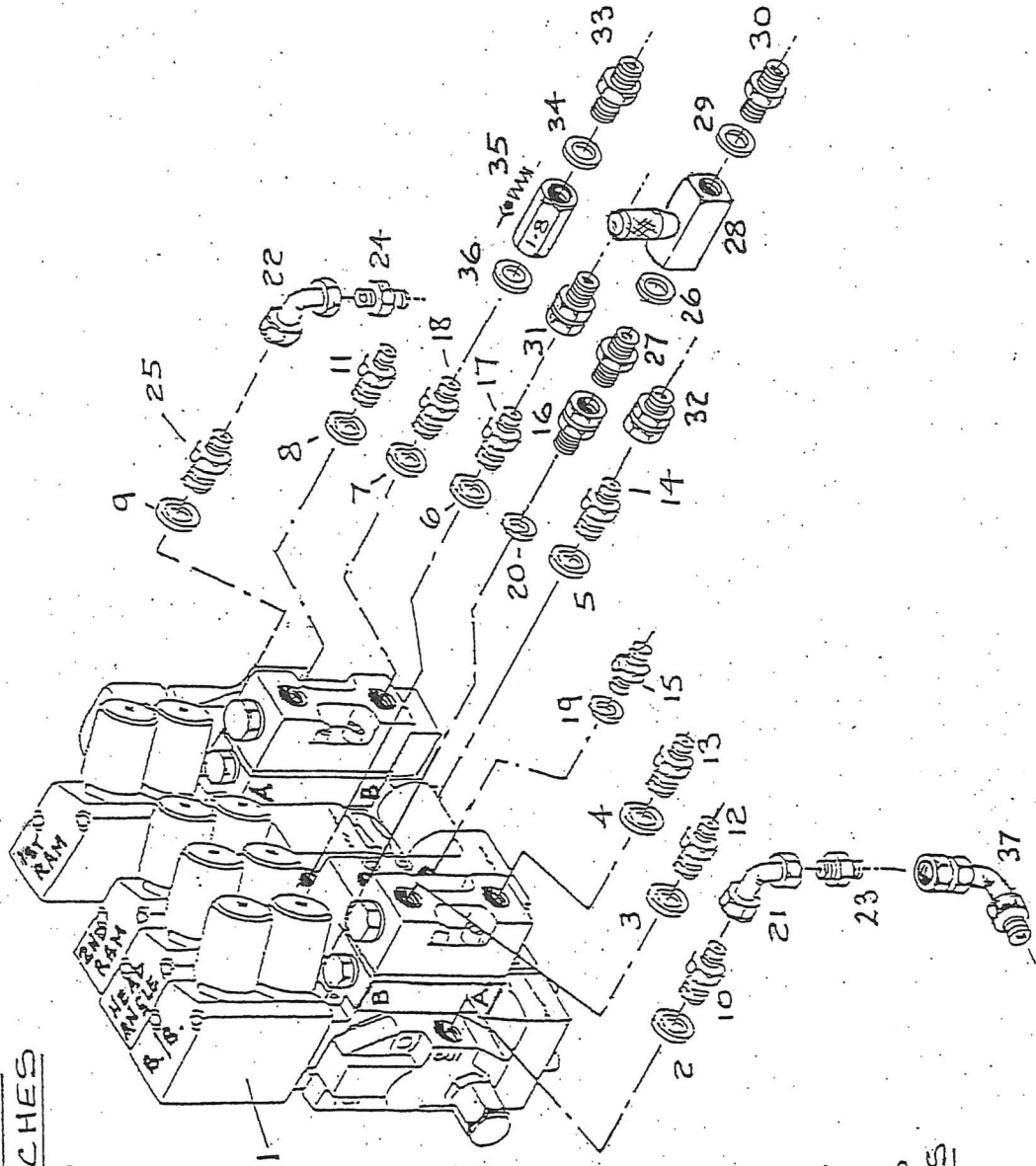

IMPORTANT

WITH VALVE FITTED-ALL  
TOP PORTS MUST BE  
CONNECTED TO ROD ENDS  
OF RELEVANT CYLINDERS

460, 520 AND 580 HEDGETRIMMER  
HYDRAULIC VALVE AND FITTINGS  
(ELECTRIC SWITCH CONTROL) CONTINUED

<u>ITEM</u>	<u>PART NO</u>	<u>DESCRIPTION</u>	<u>QTY</u>
32	7305	Adaptor 1/4" BSP M/FM	1
33	1823	Adaptor 1/4" BSP	1
34	1181	Seal 1/4" BSP	1
35	7813	Restricted one way fitting (1.8)	1
36	1181	Seal 1/4" BSP	1
37	7075	Adaptor 1/2 x 1/2" M/FM 90°	1
* * * *	3038 3001 3111 187.098	Bolt M8 x 40 (8.8) (Valve to Valve plate) Washer M8 Spring (Valve to Valve plate) Washer M8 flat- Form A (Valve to Valve plate) Spacer (Valve to Valve plate)	4 4 4 4

NOTE: Standard mounting plate 184.407 used for this build.

NOTE: Hoses for electric switchable valve machines, remain same as for cable operator machines.

