

TWOSE TREESAW

Models: TS1401 / TS1601 / TS2001 / TS2401
Inc. Telehandler Carriage TS3300

Operator & Parts Manual

(Revised 07.04.15)

Publication 684

Part No. 22674.84

IMPORTANT VERIFICATION OF WARRANTY REGISTRATION



DEALER WARRANTY INFORMATION & REGISTRATION VERIFICATION

It is imperative that the selling dealer registers this machine with Twose of Tiverton Limited before delivery to the end user – failure to do so may affect the validity of the machine warranty.

To register machines go to the Twose web site at www.twose.com, log onto 'Dealer Inside' and select the 'Machine Registration button' which can be found in the Service Section of the site. Confirm to the customer that the machine has been registered in the section below.

Should you experience any problems registering a machine in this manner please contact the Twose Office on 01884 253691.

Registration Verification

Dealer Name:
Dealer Address:
Customer Name:
Date of Warranty Registration:/...../..... Dealer Signature:

NOTE TO CUSTOMER / OWNER

Please ensure that the above section above has been completed and signed by the selling dealer to verify that your machine has been registered with Twose of Tiverton Limited.

IMPORTANT: During the initial 'bedding in' period of a new machine it is the customer's responsibility to regularly inspect all nuts, bolts and hose connections for tightness and re-tighten if required. New hydraulic connections occasionally weep small amounts of oil as the seals and joints settle in – where this occurs it can be cured by re-tightening the connection – *refer to torque settings chart below*. The tasks stated above should be performed on an hourly basis during the first day of work and at least daily thereafter as part of the machines general maintenance procedure.

TORQUE SETTINGS FOR HYDRAULIC FITTINGS

HYDRAULIC HOSE ENDS		
BSP	Setting	Metric
1/4"	18 Nm	19 mm
3/8"	31 Nm	22 mm
1/2"	49 Nm	27 mm
5/8"	60 Nm	30 mm
3/4"	80 Nm	32 mm
1"	125 Nm	41 mm
1.1/4"	190 Nm	50 mm
1.1/2"	250 Nm	55 mm
2"	420 Nm	70 mm

PORT ADAPTORS WITH BONDED SEALS		
BSP	Setting	Metric
1/4"	34 Nm	19 mm
3/8"	47 Nm	22 mm
1/2"	102 Nm	27 mm
5/8"	122 Nm	30 mm
3/4"	149 Nm	32 mm
1"	203 Nm	41 mm
1.1/4"	305 Nm	50 mm
1.1/2"	305 Nm	55 mm
2"	400 Nm	70 mm

WARRANTY POLICY

WARRANTY REGISTRATION

All machines must be registered, by the selling dealer with Twose of Tiverton Ltd, before delivery to the end user. On receipt of the goods it is the buyer's responsibility to check that the Verification of Warranty Registration in the Operator's Manual has been completed by the selling dealer.

1. LIMITED WARRANTIES

- 1.01. *All machines supplied by Twose of Tiverton Ltd are warranted to be free from defects in material and workmanship from the date of sale to the original purchaser for a period of 12 months, unless a different period is specified.*
- 1.02. *All spare parts supplied by Twose of Tiverton Ltd and purchased by the end user are warranted to be free from defects in material and workmanship from the date of sale to the original purchaser for a period of 6 months. All parts warranty claims must be supported by a copy of the failed part invoice to the end user. We cannot consider claims for which sales invoices are not available.*
- 1.03. *The warranty offered by Twose of Tiverton Ltd is limited to the making good by repair or replacement for the purchaser any part or parts found, upon examination at its factory, to be defective under normal use and service due to defects in material or workmanship. Returned parts must be complete and unexamined. Pack the component(s) carefully so that any transit damage is avoided. All ports on hydraulic items should be drained of oil and securely plugged to prevent seepage and foreign body ingress. Certain other components, electrical items for example, may require particular care when packing to avoid damage in transit.*
- 1.04. *This warranty does not extend to any product from which Twose of Tiverton Ltd's serial number plate has been removed or altered.*
- 1.05. *This warranty does not apply to any part of the goods, which has been subjected to improper or abnormal use, negligence, alteration, modification, fitment of non-genuine parts, accident damage, or damage resulting from contact with overhead power lines, damage caused by foreign objects (e.g. stones, iron, material other than vegetation), failure due to lack of maintenance, use of incorrect oil or lubricants, contamination of the oil, or which has served its normal life. This warranty does not apply to any expendable items such as blades, belts, clutch linings, filter elements, flails, flap kits, skids, soil engaging parts, shields, guards, wear pads, pneumatic tyres or tracks.*
- 1.06. *Temporary repairs and consequential loss - i.e. oil, downtime and associated parts are specifically excluded from the warranty.*
- 1.07. *Warranty on hoses is limited to 12 months and does not include hoses which have suffered external damage. Only complete hoses may be returned under warranty, any which have been cut or repaired will be rejected.*
- 1.08. *Machines must be repaired immediately a problem arises. Continued use of the machine after a problem has occurred can result in further component failures, for which Twose of Tiverton Ltd cannot be held liable, and may have safety implications.*
- 1.09. *If in exceptional circumstances a non Twose of Tiverton Ltd part is used to effect a repair, warranty reimbursement will be at no more than Twose of Tiverton Ltd's standard dealer cost for the genuine part.*
- 1.10. *Except as provided herein, no employee, agent, dealer or other person is authorised to give any warranties of any nature on behalf of Twose of Tiverton Ltd.*
- 1.11. *For machine warranty periods in excess of 12 months the following additional exclusions shall apply:*
 - 1.11.1. *Hoses, exposed pipes and hydraulic tank breathers.*
 - 1.11.2. *Filters.*
 - 1.11.3. *Rubber mountings.*
 - 1.11.4. *External electric wiring.*
 - 1.11.5. *Bearings and seals.*

- 1.12. All service work, particularly filter changes, must be carried out in accordance with the manufacturer's service schedule. Failure to comply will invalidate the warranty. In the event of a claim, proof of the service work being carried out may be required.
- 1.13. Repeat or additional repairs resulting from incorrect diagnosis or poor quality previous repair work are excluded from warranty.

NB Warranty cover will be invalid if any non-genuine parts have been fitted or used. Use of non-genuine parts may seriously affect the machine's performance and safety. Twose of Tiverton Ltd cannot be held responsible for any failures or safety implications that arise due to the use of non-genuine parts.

2. REMEDIES AND PROCEDURES

- 2.01. The warranty is not effective unless the Selling Dealer registers the machine, via the Twose of Tiverton Ltd web site and confirms the registration to the purchaser by completing the confirmation form in the operator's manual.
- 2.02. Any fault must be reported to an authorised Twose of Tiverton Ltd dealer as soon as it occurs. Continued use of a machine, after a fault has occurred, can result in further component failure for which Twose of Tiverton Ltd cannot be held liable.
- 2.03. Repairs should be undertaken within two days of the failure. Claims submitted for repairs undertaken more than 2 weeks after a failure has occurred, or 2 days after the parts were supplied will be rejected, unless the delay has been authorised by Twose of Tiverton Ltd. Please note that failure by the customer to release the machine for repair will not be accepted as a reason for delay in repair or submitting warranty claims.
- 2.04. All claims must be submitted, by an authorised Twose of Tiverton Ltd Service Dealer, within 30 days of the date of repair.
- 2.05. Following examination of the claim and parts, Twose of Tiverton Ltd will pay, at their discretion, for any valid claim the invoiced cost of any parts supplied by Twose of Tiverton Ltd and appropriate labour and mileage allowances if applicable.
- 2.06. The submission of a claim is not a guarantee of payment.
- 2.07. Any decision reached by Twose of Tiverton Ltd is final.

3. LIMITATION OF LIABILITY

- 3.01. Twose of Tiverton Ltd disclaims any express (except as set forth herein) and implied warranties with respect to the goods including, but not limited to, merchantability and fitness for a particular purpose.
- 3.02. Twose of Tiverton Ltd makes no warranty as to the design, capability, capacity or suitability for use of the goods.
- 3.03. Except as provided herein, Twose of Tiverton Ltd shall have no liability or responsibility to the purchaser or any other person or entity with respect to any liability, loss, or damage caused or alleged to be caused directly or indirectly by the goods including, but not limited to, any indirect, special, consequential, or incidental damages resulting from the use or operation of the goods or any breach of this warranty. Notwithstanding the above limitations and warranties, the manufacturer's liability hereunder for damages incurred by the purchaser or others shall not exceed the price of the goods.
- 3.04. No action arising out of any claimed breach of this warranty or transactions under this warranty may be brought more than one (1) year after the cause of the action has occurred.

4. MISCELLANEOUS

- 4.01. Twose of Tiverton Ltd may waive compliance with any of the terms of this limited warranty, but no waiver of any terms shall be deemed to be a waiver of any other term.
- 4.02. If any provision of this limited warranty shall violate any applicable law and is held to be unenforceable, then the invalidity of such provision shall not invalidate any other provisions herein.
- 4.03. Applicable law may provide rights and benefits to the purchaser in addition to those provided herein.

EC Declaration of Conformity

**Conforming to EEC directive
2006/42/EF**



We GreenTec A/S, Merkurvej 25, DK-6000 Kolding, declare under our sole responsibility that the

Product	Quadsaw (Treesaw) / Carriage Unit
Models	1401 / 1601 / 2001 / 2401 / TS3300
Serial no.	
Type	4 blade Saw

Manufactured by the above company, according to the announcement no. 693 of 10. Jun 2013 that implements the DIRECTIVE 2006/42/EF.

On behalf of GreenTec A/S
Merkurvej 25
DK-6000 Kolding

Date 16/3-2006

Signature 

Status John Christensen. Sales Director

CONTENTS

Operation Section

General Information	2
Safety Information	3
Safety Decals	7
Vehicle Preparation	8
Treesaw Overview	9
Treesaw Installation	10
Treesaw Operation	11
Treesaw Maintenance	12
TS3300 Mounting Carriage	14
TS3300 Attachment	14
TS3300 Transport & Work Positions	15
TS3300 Operation	16
TS3300 Valves & Electrics	16
TS3300 Maintenance	19

Parts Section

Main Assembly – <i>Treesaw TS1401 Model</i>	24
Blade Assembly – <i>Treesaw TS1401 Model</i>	26
Motor Plate Assembly – <i>Treesaw TS1401 Model</i>	28
Tensioner Assembly – <i>Treesaw TS1401 Model</i>	29
Main Assembly – <i>Treesaw TS1601 Model</i>	30
Drive Assembly - <i>Treesaw TS1601 Model</i>	32
Blade Unit - <i>Treesaw TS1601 Model</i>	34
Main Frame - <i>Treesaw TS2001 / TS2401 Models</i>	36
Blade Shaft - <i>Treesaw TS2001 / TS2401 Models</i>	38
Adjusting System - <i>Treesaw TS2001 / TS2401 Models</i>	39
Piston Motor - <i>Treesaw TS2001 / TS2401 Models</i>	40
Machine Decals	41
TS3300 Loader Carriage - <i>Treesaw TS2001 / TS2401 Models</i>	42
Loader Carriage Valve	43

GENERAL INFORMATION

Read this manual before fitting or operating the machine or accessory. Whenever any doubt exists contact your local dealer or the Twose of Tiverton Service Department for assistance.

Only use 'Genuine Twose Parts' on Twose machinery and equipment.

DEFINITIONS: *The following definitions apply throughout this manual;*

⚠ DANGER

DANGER: Alerts to a hazardous situation which will result in death or serious injury if not observed carefully.

⚠ WARNING

WARNING: Alerts to a hazardous situation which could result in death or serious injury if not observed carefully.

⚠ CAUTION

CAUTION: Alerts to a hazardous situation which could result in damage to the machine and/or equipment if not observed carefully.

NOTICE

NOTICE: Specific or general information considered important or useful to emphasise.

LEFT HAND (LH) & RIGHT HAND (RH): *These terms are applicable to the machine when fitted to the tractor and viewed from the rear; these terms also apply to tractor references.*

SERIAL PLATE

All machines are equipped with a serial number plate containing important information relating to the machine including a unique serial number used for identification purposes.

Note: Images in this manual are provided for instruction and informational purposes only and may not show components in their entirety. In certain instances images may appear different to the actual machine; where this occurs the general procedure will be basically the same. E&OA.

MACHINE & DEALER INFORMATION

Record the serial number of your machine on this page and always quote it when ordering parts. Whenever information concerning the machine is requested remember to also state the make and model of tractor to which the machine is fitted.	
Machine Serial Number:	Installation Date:
Machine Model Details:	
Dealer Name & Branch:	
Dealer Address:	
Dealer Telephone No:	
Dealer Email Address:	



This machine has the potential to be extremely dangerous - in the wrong hands it can kill or maim; it is therefore imperative that both owner and operator of the machine reads and understands the following section to ensure they are fully aware of the dangers that do, or may exist, and their responsibilities surrounding the use and operation of the machine. The operator of this machine is responsible not only for their own safety but equally for the safety of others who may come into the close proximity of the machine, as the owner you are responsible for both.

All operators must be fully competent in the use of this machine and also the machine to which it is attached and must read and understand the operation manuals for both machines before attempting to attach or operate this equipment.

When the machine is not in use it should be lowered to rest on the ground. In the event of any fault being detected with the machine's operation it must be stopped immediately and not used again until the fault has been corrected by a qualified technician

POTENTIAL DANGERS ASSOCIATED WITH THE USE OF THIS MACHINE:

- ▲ *Being hit by debris thrown by rotating components.*
- ▲ *Being hit by machine parts ejected through damage during use.*
- ▲ *Being caught on a rotating power take-off (PTO) shaft.*
- ▲ *Being caught in other moving parts i.e.: belts, pulleys and cutting heads.*
- ▲ *Electrocution from Overhead Power Lines (by contact with or 'flashover' from).*
- ▲ *Being hit by cutting heads or machine arms as they move.*
- ▲ *Becoming trapped between tractor and machine when hitching or unhitching.*
- ▲ *Tractor overbalancing when machine arm is extended.*
- ▲ *Injection of high-pressure oil from hydraulic hoses or couplings.*
- ▲ *Machine overbalancing when freestanding (out of use).*
- ▲ *Road traffic accidents due to collision or debris on the road.*

BEFORE USING THIS MACHINE YOU MUST:

- ▲ *Ensure you read all sections of the operator handbook.*
- ▲ *Ensure the operator is, or has been, properly trained to use the machine.*
- ▲ *Ensure the operator has been issued with and reads the operator handbook.*
- ▲ *Ensure the operator understands and follows the instructions in operator handbook.*
- ▲ *Ensure the tractor front, rear and sides are fitted with metal mesh or polycarbonate guards of suitable size and strength to protect the operator against thrown debris or parts.*
- ▲ *Ensure tractor guards are fitted correctly, are undamaged and kept properly maintained.*
- ▲ *Ensure that all machine guards are in position, are undamaged, and are kept maintained in accordance with the manufacturer's recommendations.*
- ▲ *Ensure blades and their fixings are of a type recommended by the manufacturer, are securely attached and that none are missing or damaged.*
- ▲ *Ensure hydraulic pipes are carefully and correctly routed to avoid damage by chaffing, stretching or pinching and that they are held in place with the correct fittings.*
- ▲ *Always follow the manufacturer's instructions for attachment and removal of the machine from the tractor.*
- ▲ *Check that the machine fittings and couplings are in good condition.*
- ▲ *Ensure the tractor meets the minimum weight recommendations of the machine's manufacturer and that ballast is used as necessary.*
- ▲ *Always inspect the work area thoroughly before starting to note obstacles and remove wire, bottles, cans and other debris.*
- ▲ *Use clear suitably sized warning signs to alert others to the nature of the machine working within that area. Signs should be placed at both ends of the work site. (It is recommended that signs used are of a size and type specified by the Department of Transport and positioned in accordance with their, and the Local Highways Authority, guidelines).*
- ▲ *Ensure the operator is protected from noise. Ear defenders should be worn and tractor cab doors and windows must be kept closed. Machine controls should be routed through proprietary openings in the cab to enable all windows to be shut fully.*
- ▲ *Always work at a safe speed taking account of the conditions i.e.: terrain, highway proximity and obstacles around and above the machine. Extra special attention should be applied to Overhead Power Lines. Some of our machines are capable of reach in excess of 8 metres (26 feet) this means they have the potential to well exceed, by possibly 3 metres (9' 9"), the lowest legal minimum height of 5.2 metres from the ground for 11,000 and 33,000 volt power lines. It cannot be stressed enough the dangers that surround this capability, it is therefore vital that the operator is fully aware of the maximum height and reach of the machine, and that they are fully conversant with all aspects regarding the safe minimum distances that apply when working with machines in close proximity to Power Lines. (Further information on this subject can be obtained from the Health & Safety Executive or your Local Power Company).*

- ▲ *Always disengage the machine, kill the tractor engine, remove and pocket the key before dismounting for any reason.*
- ▲ *Always clear up all debris left at the work area, it may cause hazard to others.*
- ▲ *Always ensure when you remove your machine from the tractor that it is left in a safe and stable position using the stands and props provided and secured if necessary.*

WHEN NOT TO USE THIS MACHINE:

- ▲ *Never attempt to use this machine if you have not been trained to do so.*
- ▲ *Never use a machine until you have read and understood the operator handbook, are familiar with it, and practiced the controls.*
- ▲ *Never use a machine that is poorly maintained.*
- ▲ *Never use a machine if guards are missing or damaged.*
- ▲ *Never use a machine on which the hydraulic system shows signs of wear or damage.*
- ▲ *Never fit, or use, a machine on a tractor that does not meet the manufacturer's minimum specification level.*
- ▲ *Never use a machine fitted to a tractor that does not have suitable front, rear and side(s) cab guarding made of metal mesh or polycarbonate.*
- ▲ *Never use the machine if the tractor cab guarding is damaged, deteriorating or badly fitted.*
- ▲ *Never turn a machine cutting head to an angle that causes debris to be ejected towards the cab.*
- ▲ *Never start or continue to work a machine if people are nearby or approaching - Stop and wait until they are at a safe distance before continuing. WARNING: Some cutting heads may continue to 'freewheel' for up to 40 seconds or more after being stopped.*
- ▲ *Never attempt to use a machine on materials in excess of its capability.*
- ▲ *Never use a machine to perform a task it has not been designed to do.*
- ▲ *Never operate the tractor or machine controls from any position other than from the driving seat, especially whilst hitching or unhitching the machine.*
- ▲ *Never carry out maintenance of a machine or a tractor whilst the engine is running – the engine should be switched off, the key removed and pocketed.*
- ▲ *Never leave a machine unattended in a raised position – it should be lowered to the ground in a safe position on a level firm site.*
- ▲ *Never leave a tractor with the key in or the engine running.*
- ▲ *Never carry out maintenance on any part or component of a machine that is raised unless that part or component has been properly substantially braced or supported.*
- ▲ *Never attempt to detect a hydraulic leak with your hand – use a piece of cardboard.*
- ▲ *Never allow children near to, or play on, a tractor or machine under any circumstances.*

ADDITIONAL SAFETY ADVICE

Training

Operators need to be competent and fully capable of operating this machine in a safe and efficient way prior to attempting to use it in any public place. We advise therefore that the prospective operator make use of relevant training courses available such as those run by the Agricultural Training Board, Agricultural Colleges and Dealers.

Working in Public Places

When working in public places such as roadsides, consideration should be paid to others in the vicinity. Stop the machine immediately when pedestrians, cyclists and horse riders etc. pass. Restart only when they are at a distance that causes no risk to their safety.

Warning Signs

It is advisable that any working area be covered by suitable warning signs and statutory in public places. Signs should be highly visible and well placed in order to give clear advanced warning of the hazard. Contact the Department of Transport or your Local Highways Authority to obtain detailed information on this subject. The latter should be contacted prior to working on the public highway advising them of the time and location of the intended work asking what is required by way of signs and procedure. – ‘*Non-authorized placement of road signs may create offences under the Highways Act*’.

Suggested Warning Signs Required

‘Road works ahead’ warning sign with a supplementary ‘Hedge cutting’ plate. ‘For 1 mile’ or appropriate shorter distance may be added to the plate.

‘Road narrows’ warning signs with supplementary ‘Single file traffic’ plate.

White on blue ‘Keep right’ () arrow sign on rear of machine.*

** Note – this applies to UK Market machines where traffic passes to the right of a machine working in the same direction as the traffic flow. The direction, use and colour of the arrow sign will depend on the country of use and the Local Highway Authorities regulations in the locality.*

Use of Warning Signs

- ▲ *On two-way roads one set of signs is needed facing traffic in each direction.*
- ▲ *Work should be within 1 mile of the signs.*
- ▲ *Work only when visibility is good and at times of low risk e.g.: NOT during ‘rush-hour’.*
- ▲ *Vehicles should have an amber-flashing beacon.*
- ▲ *Ideally, vehicles should be conspicuously coloured.*
- ▲ *Debris should be removed from the road and path as soon as practicable, and at regular intervals, wearing high visibility clothing and before removing the hazard warning signs.*
- ▲ *Collect all road signs promptly when the job is completed.*

Safety Gear: It is recommended that the following personal protective equipment is worn when operating and/or maintaining this machine; Coveralls, safety boots, safety glasses, hearing protection, safety helmet, protective gloves, protective dust mask.



Although the information stated here covers a wide range of safety subjects it is impossible to predict every eventuality that can occur under differing circumstances whilst operating this machine. No advice given here can replace ‘good common sense’ and ‘total awareness’ at all times, but will go a long way towards the safe use of your Twose machine.

SAFETY DECALS



WARNING
Pressurised oil, beware of leaks.
Consult technical manual for
service procedures.



WARNING
Stop engine and remove key
before performing maintenance
or repair work.



WARNING
Danger – flying objects. Keep a
safe distance from the machine
when the engine is running.



WARNING
Check tightness of bolts every 8
hours – retighten if required.



WARNING
Danger - keep clear of rotating
blades.



WARNING
Read the operator's manual
before handling or using the
machine. Observe the safety
rules when operating.



WARNING
Keep clear of the machines
swing area.



WARNING
Danger - keep clear of overhead
power lines.
Where doubt exists, contact your
local power company for advice.

VEHICLE / TRACTOR PREPARATION

We recommend vehicles are fitted with cabs using 'safety glass' windows and protective guarding when used with our machines.

Fit Operator Guard (Part No. 7313324) using the hooks provided. Shape the mesh to cover all vulnerable areas. The driver must be looking through mesh and/or polycarbonate glazing when viewing the flail head in any working position - unless the vehicle/ cab

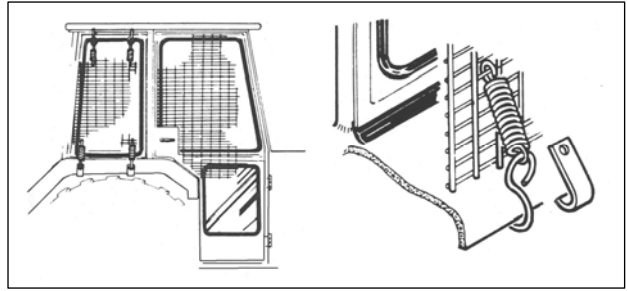

manufacturer can demonstrate that the penetration resistance is equivalent to, or higher than, that provided by mesh/polycarbonate glazing. If the tractor has a roll bar only, a frame must be made to carry both mesh and polycarbonate glazing. The operator should also use personal protective equipment to reduce the risk of serious injury such as; eye protection (mesh visor to EN1731 or safety glasses to EN166), hearing protection to EN352, safety helmet to EN297, gloves, filter mask and high visibility clothing.

Vehicle Ballast: It is imperative when attaching 'third-party' equipment to a vehicle that the maximum possible stability of the machine and vehicle combination is achieved – this can be accomplished by the utilisation of 'ballast' in order to counter-balance the additional equipment added.

Front weights may be required for rear mounted machines to place 15% of total outfit weight on the front axle for stable transport on the road and to reduce 'crabbing' due to the drag of the cutting unit when working on the ground.

Rear weights may be required to maintain a reasonable amount of rear axle load on the opposite wheel from the arms when in work; for normal off-ground work i.e. hedge cutting this should be 20% of rear axle weight or more for adequate control, and for ground work i.e. verge mowing with experienced operators, this can be reduced to 10%.

All factors must be addressed in order to match the type and nature of the equipment added to the circumstances under which it will be used – in the instance of Power Arm hedgecutters it must be remembered that the machines centre of gravity during work will be constantly moving and will differ from that during transport mode, therefore balance becomes critical.

Factors that affect stability:

- Centre of gravity of the tractor/machine combination.
- Geometric conditions, e.g. position of the cutting head and ballast.
- Weight, track width and wheelbase of the tractor.
- Acceleration, braking, turning and the relative position of the cutting head during these operations.
- Ground conditions, e.g. slope, grip, load capability of the soil/surface.
- Rigidity of implement mounting.

Suggestions to increase stability:

- Increasing rear wheel track; a vehicle with a wider wheel track is more stable.
- Ballasting the wheel; it is preferable to use external weights but liquid can be added to around 75% of the tyre volume – water with anti-freeze or the heavier Calcium Chloride alternative can be used.
- Addition of weights – care should be taken in selecting the location of the weights to ensure they are added to a position that offers the greatest advantage.
- Front axle locking (check with tractor manufacturer).

NOTE: The advice above is offered as a guide for stability only and is not a guide to vehicle strength. It is recommended that you consult your vehicle manufacturer or local dealer to obtain specific advice on this subject, additionally advice should be sought from a tyre specialist with regard to tyre pressures and ratings suitable for the type and nature of the machine you intend to fit.

OVERVIEW

Two Treesaws TS1401, TS1601, TS2001 and TS2401 are a range of hydraulic arm mounted 4 blade saw units used for the cutting of trees and branches. Available in widths of 1.4, 1.6, 2.1 & 2.4m the machines are equipped with 340mm, 400mm, 500mm & 600mm 'belt-driven' blades respectively.

The machines have the following cutting capabilities;

TS1401 up to 50mm diameter material (up to 70mm when cutting single branches)

TS1601 up to 70mm diameter material (up to 100mm when cutting single branches)

TS2001 up to 80mm diameter material (up to 120mm when cutting single branches)

TS2401 up to 120mm diameter material (up to 160mm when cutting single branches)

Best performance is achieved if the unit is angled at no more than 45° from the upright when vertical cutting.

When working horizontally on hedges, best performance will be achieved on hedge widths of less than 100mm for the TS1401 and TS1601 model and less than 1200mm for the TS2001 and TS2401 models with branch diameters of up to 40mm; thicker diameter materials may cause the blades to stall or get stuck.

SPECIFICATIONS

Specification / Model	TS1401	TS1601	TS2001	TS2401
Working Width	1.4m	1.6m	2.1m	2.4m
Blade Diameter	340mm	400mm	500mm	600mm
Teeth per Blade	52	60	72	78
Blade Material	Hardened Steel	Hardened Steel	Hardened Steel	Hardened Steel
Blade Speed	2800RPM	2600-2700RPM	3000-3200RPM	2700-2800RPM
Oil Flow Rate	25 l/min	40 l/min	50 l/min	45 l/min
Cutting Performance (<i>single branch</i>)	Up to 70mm	Up to 100mm	Up to 120mm	Up to 160mm
Main Application	Vertical Cutting	Vertical Cutting	Vertical Cutting	Vertical Cutting
Weight	45kg	98kg	220kg	280kg

Noise Level

Noise measurements tests (*) by the manufacturer using an 'Elma 1350B Noise Measurer', (ICE 651 Type II), performed under normal working conditions, produced the following result;
The energy A-weighted Sound pressure is below 90 dB (A).

() Noise measurement was performed at a distance of 1 meter from the machine's critical noise maker positioned at a height of 1.5 meters above the ground.*

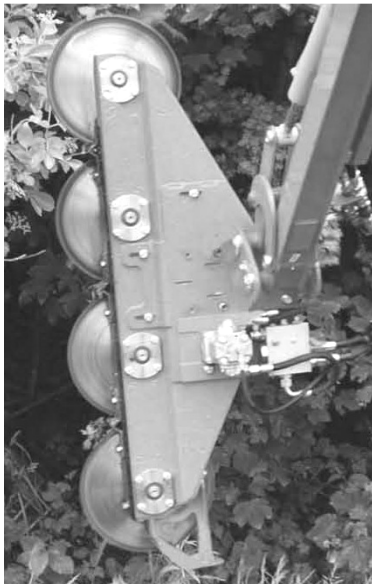

Treesaw TS1601 Model



Treesaw TS2001 & TS2401 Models

MACHINE ATTACHMENT

⚠ WARNING

Attachment of the machine must be performed in a safe location on a firm level site. Care should be adopted at all times when handling or manoeuvring the machine during the attachment procedure; ensure all persons remain clear of the cutting blades which possess the potential to cause injury even when stationary. For reasons of safety the blade guard should be fitted to machine at all times and only removed for machine operation.

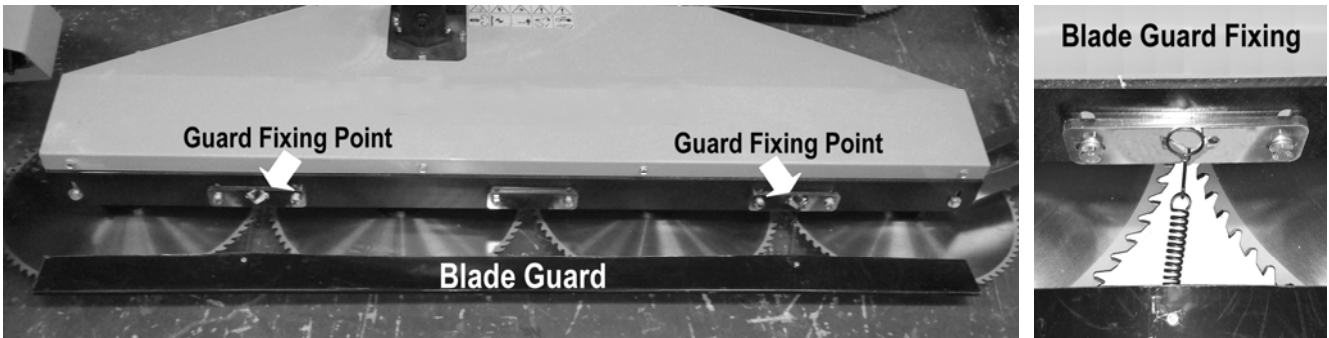

Attachment to Boom Arm

Machines are attached to boom arms with a clamp bracket; fixing nuts should be torqued to 203Nm (150 ft lb).

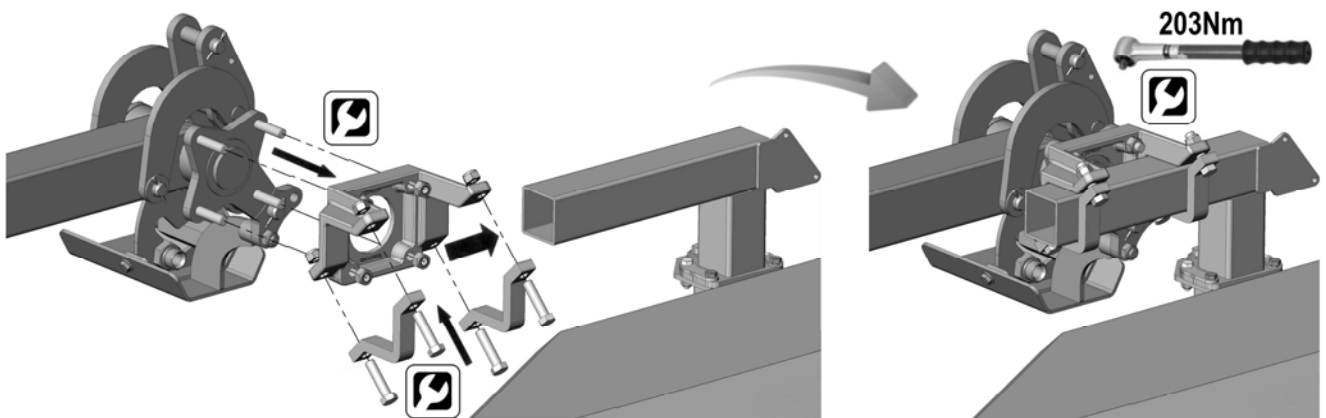

- Ensure blades are correctly mounted. Blades **MUST** be mounted in a downward cut rotation in relation to the tractors driving direction – *refer to illustrations on following page.*
- Install and connect the hydraulic hoses ensuring the correct cutting direction is achieved. The separate drainage hose (max. 1.5 bar) must be led directly back to the oil reservoir.
- Check system for leaks.
- Check belt tension before using the machine; *refer to belt tensioning section for details.*
- On initial installation the blade speed should be measured and the flow control valve adjusted to achieve the optimum working speeds of;

2800RPM for 1.4m models (*Treesaw TS1401*)

2600-2700RPM for 1.6m models (*Treesaw TS1601*)

3000-3200RPM for 2.1m models (*Treesaw TS2001*)

2700-2800RPM for 2.4m models (*Treesaw TS2401*)

Blade Cutting Direction

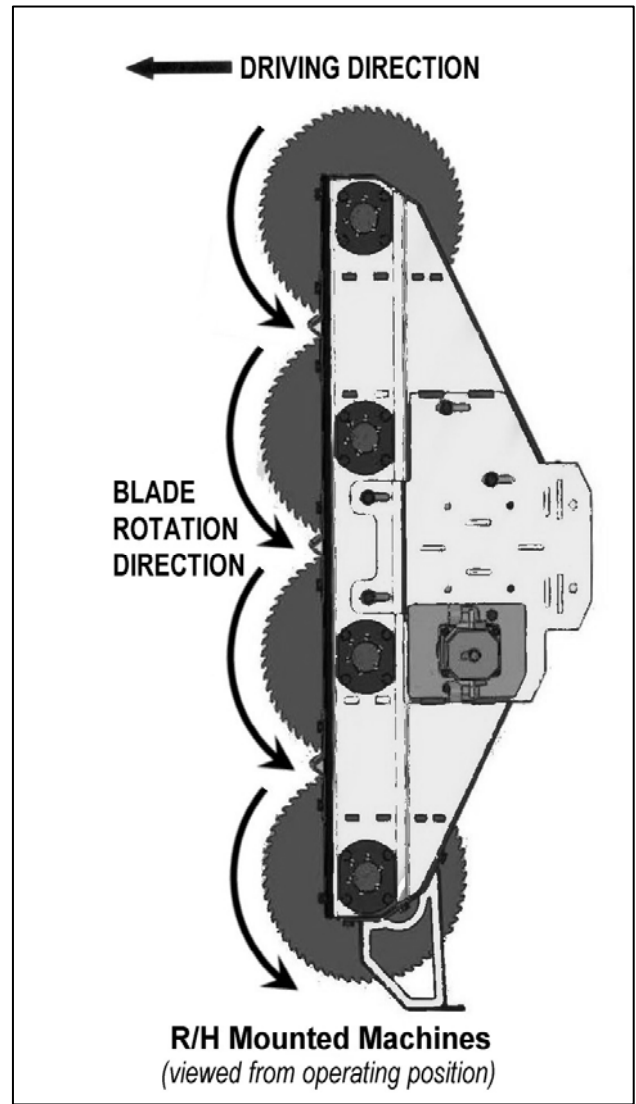
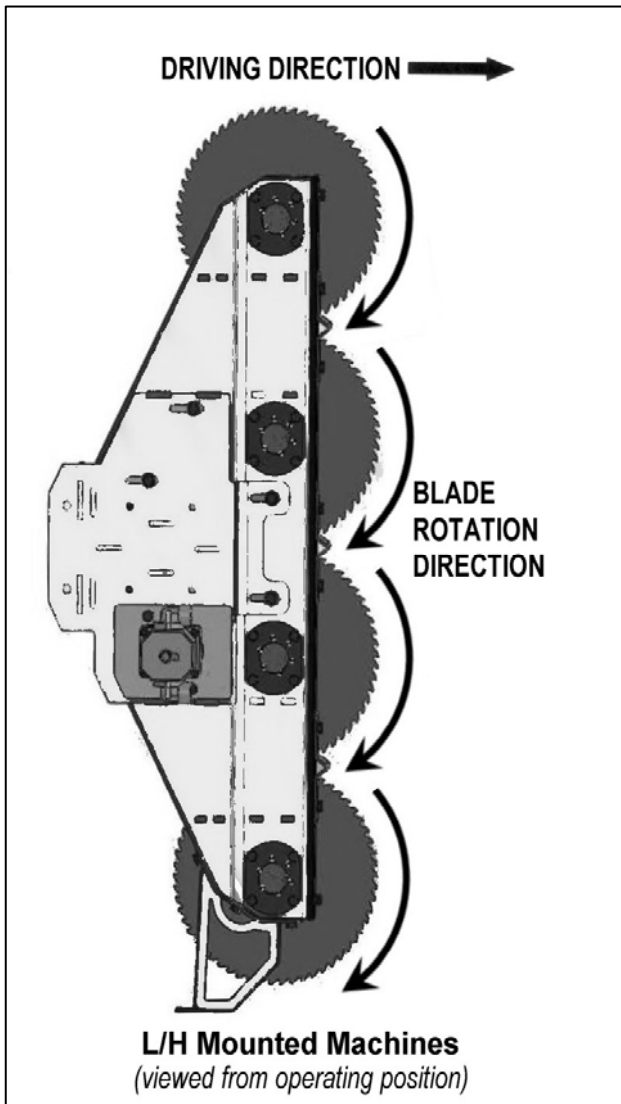

⚠ WARNING Blades must be mounted to cut in a downward direction only.

TREESAW OPERATION

It is recommended that forward speed is kept to a minimum when starting work in order to retain the correct working speed of the blades. Set the angle of the Treesaw so it is positioned at right angles to the work and adjust the machine position so the branches meet the saw blades 'straight on'.

Wherever possible try to keep the blades running vertical in relation to the direction of travel, this will help prevent them from 'distorting' during operations.

A skid is available as an option which can be mounted on the base of the machine to prevent the blades from hitting the ground.

Should small branches, debris or unwanted material get stuck in the blades the **machine and tractor must be switched off** and the starting key removed before attempting to clear the blockage. If necessary, remove the belt cover to gain better access to the blockage; replace cover immediately before starting or using the machine.

⚠ WARNING Never attempt to run the machine with the belt cover removed.

⚠ WARNING Great care must taken when attempting to clear debris from the blade and/or belt area of the machine; sharp components and numerous pinch risk points exist in these locations. Safety gloves and safety eyewear should be worn and wherever possible the use a suitable tool should be used to remove any debris to ensure hands and fingers are kept clear of any risk areas.

When in charge of the machine always obey the following rules;

- Always inspect the work area prior to operation and remove any dangerous materials.
- Never operate the machine with persons or animals in close proximity.
- Ensure all cab guarding is in place and the tractor windows are kept shut.
- Only operate the machine at the correct blade speed.
- Never use the machine in excess of the maximum oil pressure in the hoses (250 bar, 210 bar for 1401 models).
- Never stop the engine with the PTO engaged.
- Never transport the machine with the PTO engaged.
- Never transport the machine without the blade protection guards fitted.
- Never approach the machine when it is running, always switch it off and stop the tractor.
- Always remove the tractor ignition key before leaving the cab.
- Never use the machine to perform tasks it was not designed for.
- Always lower the machine to rest on the ground with blade protection guards fitted when the unit is parked up or not in use.

TREESA W MAINTENANCE

⚠ WARNING Beware of blades and belt areas when maintaining and servicing.

Initial Maintenance

- After an initial 2 hours work, re-tighten taper-lock bushes to 31Nm.
- After the first day's work, all bolts, screws and taper-lock bushes must be re-tightened - if the bushes loosen at a future time they should be secured with 'Loctite' or similar.

Regular Maintenance

- Check all bolts and screws on a regular basis and re-tighten as and when required.
- The plastic strips should be adjusted down to a 1mm clearance from the blades – these strips must be replaced when no further adjustment is available and the clearance distance exceeds 5mm.
- Branch deflectors must be adjusted as close as possible to the blades without touching.
- Remove belt guard and clean the housing.
- Inspect belts and check their tension, adjust if required.
- Check condition of protection guards – always replace guards before using the machine.

Belts

It is important that belts are kept in good condition and are correctly tensioned at all times. The correct tensions are as follows;

Treesaw TS1401: Both belts 450Nm (*New belts 600Nm*)

Treesaw TS1601: Short belt 550Nm / Long belts 650Nm (*New belts 700Nm / 900Nm respectively*)

Treesaw TS2001: Short belt 550Nm / Long belts 650Nm (*New belts 700Nm / 900Nm respectively*)

Treesaw TS2401: Short belt 900Nm / Long belts 1100Nm (*New belts 1100Nm / 1300Nm respectively*)

TS1601 / TS2001 / TS2401 Models

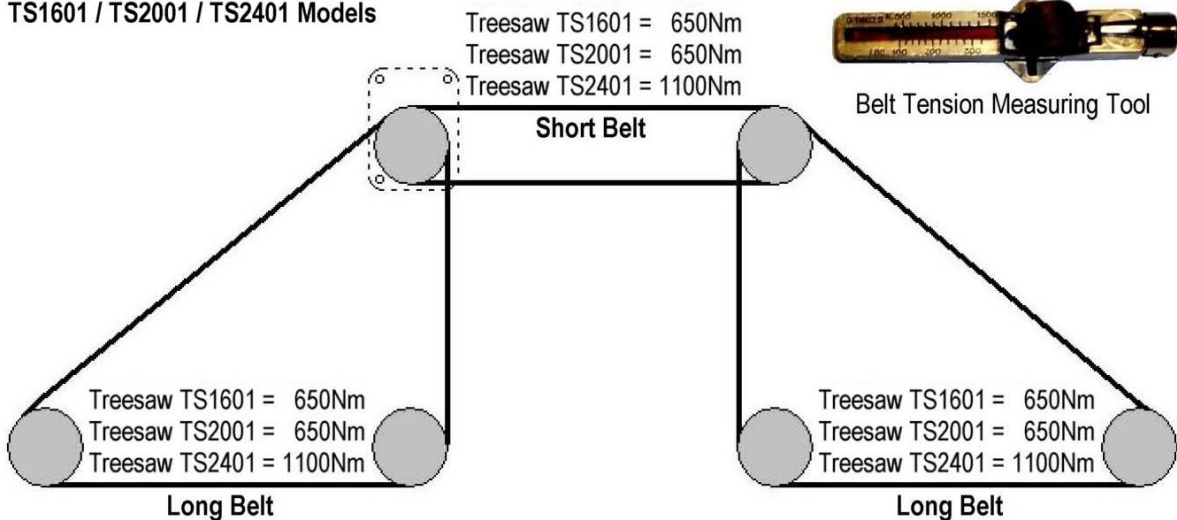

TS1401 Model

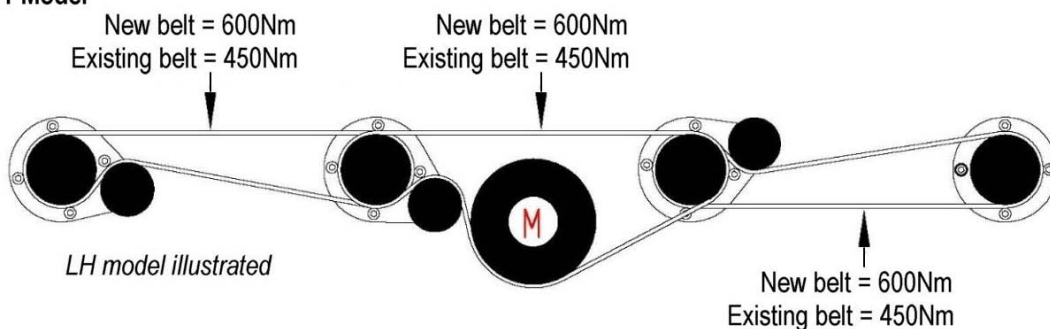

Tensioning the Belts

⚠ WARNING

Great care must be adopted when servicing this part of the machine as there is risk of trapping hands or fingers in the belts, pulleys or blades.

Loosen bolts indicated

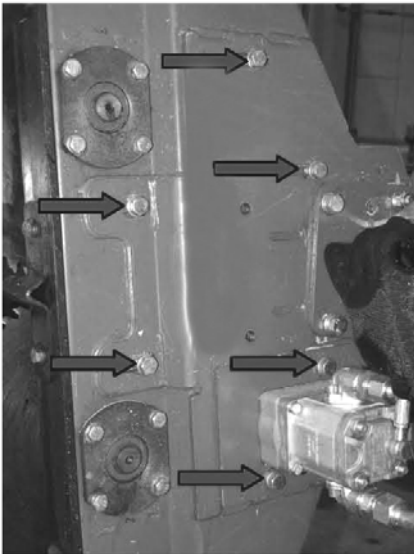

Remove cover

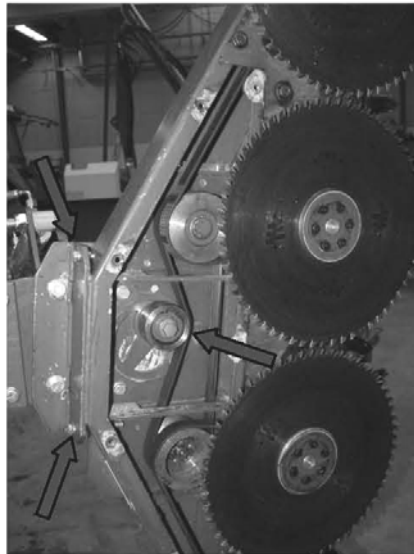

Loosen bolt and turn idler roller

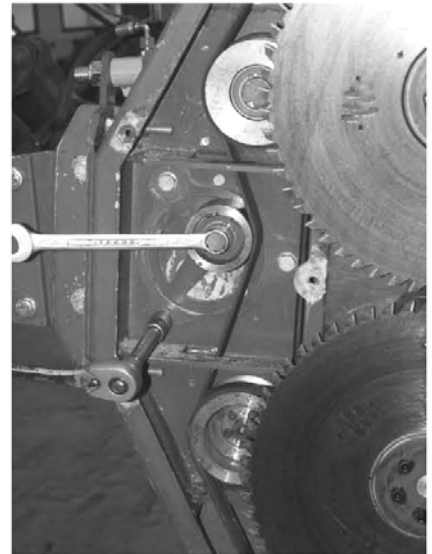

Set tension of the centre belt



Set tension of lower belt



Set tension of upper belt



Set the tensions at centre point of the belts between the pulleys, turn blades a few times and re-check.

Treesaw TS1401 - Belt Configurations / Motor Direction

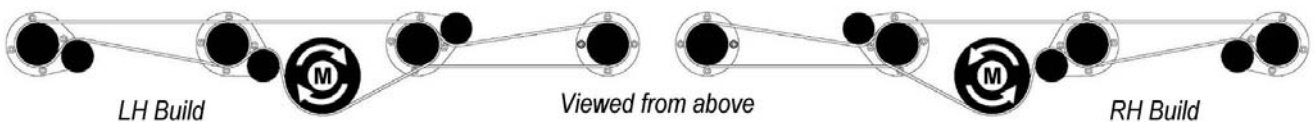

⚠ WARNING

Replace cover and tighten bolts before attempting to use the machine.

TS3300 MOUNTING CARRIAGE

The TS3300 is a mounting carriage specifically designed for attaching TS2001 and TS2401 models to Telehandlers. The TS3300 features a reach of approximately 2.5 metres, 180° manual folding system, and hydraulic collision safety. The overall weight of the unit, without tools, is 225kg. If necessary, suitable ballasting should be fitted to the vehicle to ensure the unit remains stable and balanced in all working positions under all conditions.

⚠ DANGER Never use the machine on a vehicle that is unstable or unsuitable.

ATTACHING THE CARRIAGE

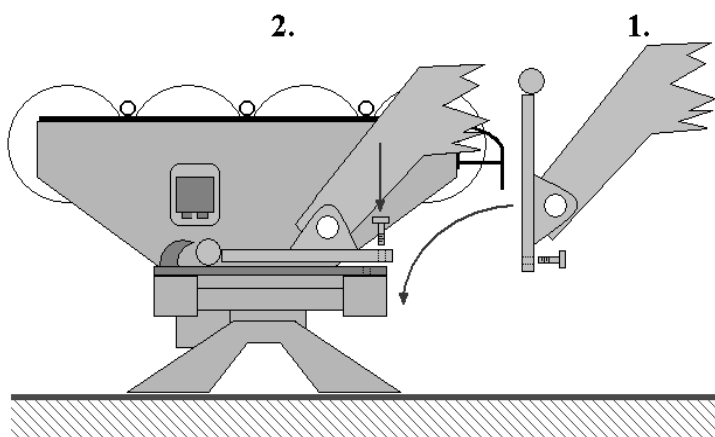

1) Drive up to the machine, tilt attachment bracket into the horizontal position.

2) Locate attachment bar into hooks and secure latches.

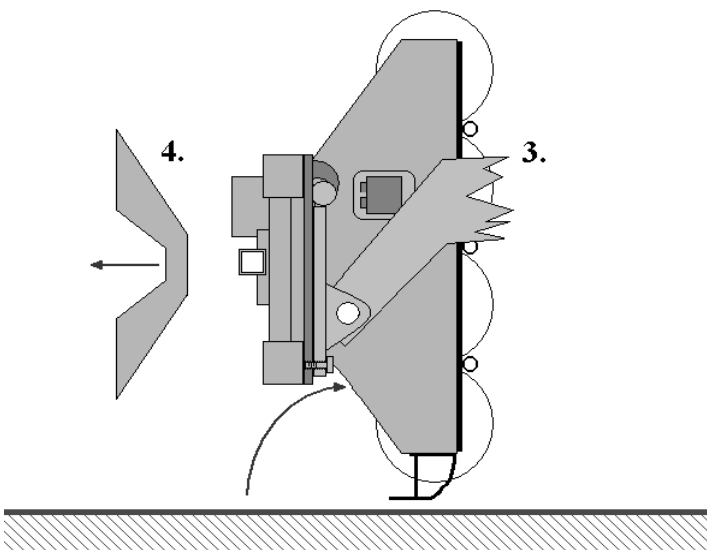

3) Tilt bracket backwards 90°.

4) Detach supporting legs.



⚠ DANGER

Keep well clear of all overhead power lines when manoeuvring or operating this machine.

TRANSPORT & WORK POSITIONS

Transport Position

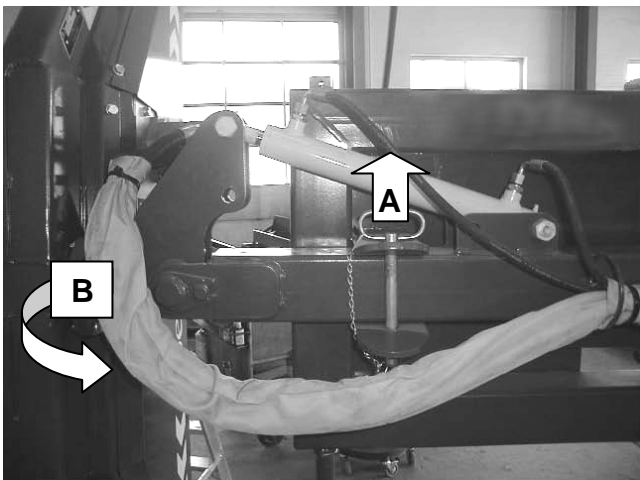

Work Position

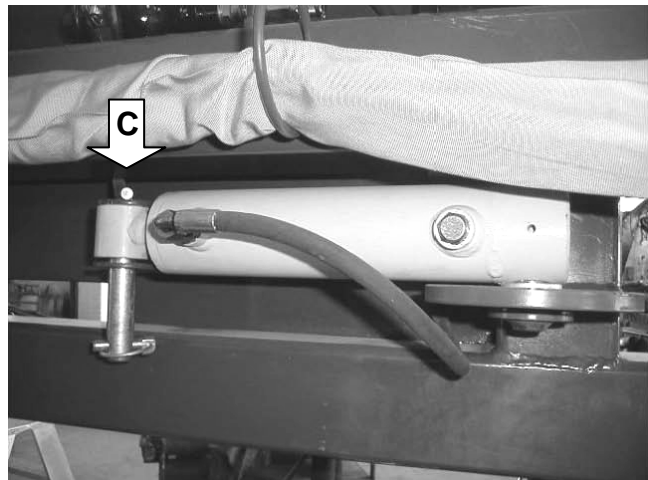

The procedure for moving the machine from transport position to work position is as follows;

- A) Remove transport pin.
- B) Manually fold the arm out by 180° into the work position.
- C) Fit and secure the ram pin.

Storage Position

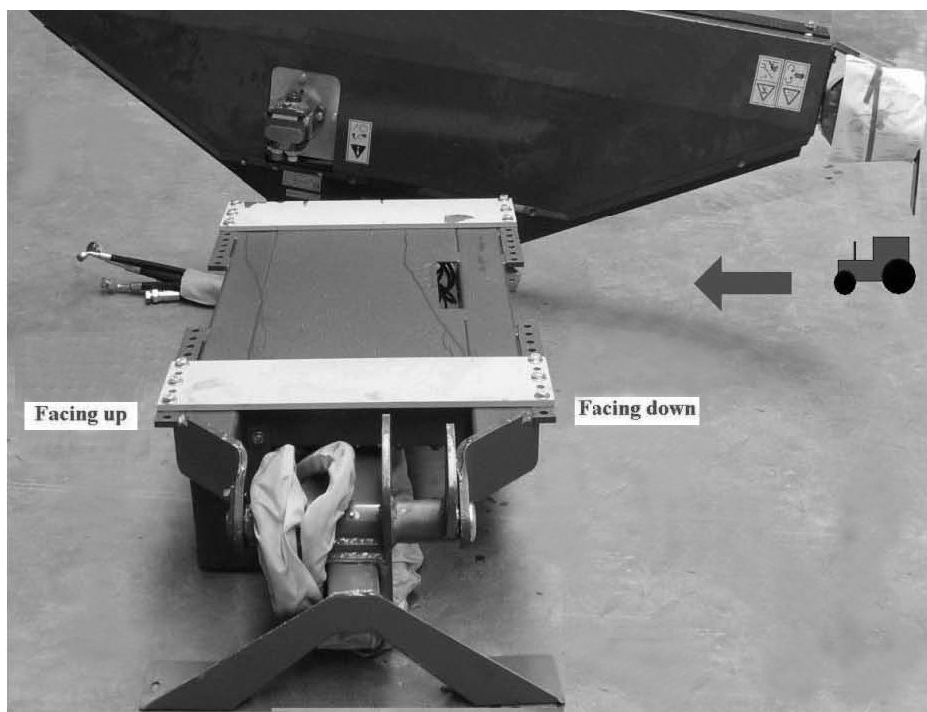

⚠ WARNING

Blade guard must be fitted when the machine is in storage or parked.

TS3300 CONTROLS

Operator Controls

- 1) On/Off Switch.
- 2) Cutting Angle Switch.
- 3) Tool On/Off Switch.
- 4) Control Unit Fuse (8 Amp).

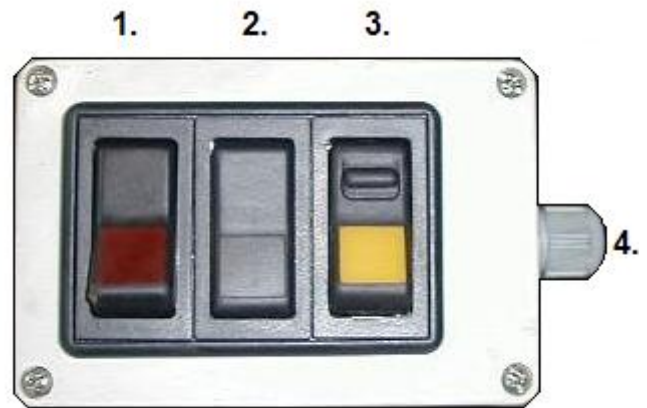

Cutting Angle Adjustment

The cutting angle is adjusted hydraulically by operation of the rocker switch (2); operate the switch in the required direction to set the desired cutting angle before starting work. The angle switch may be operated during work to make minor angling adjustments, but it is recommended to halt work before making major adjustments to the cutting angle.

Valve Unit

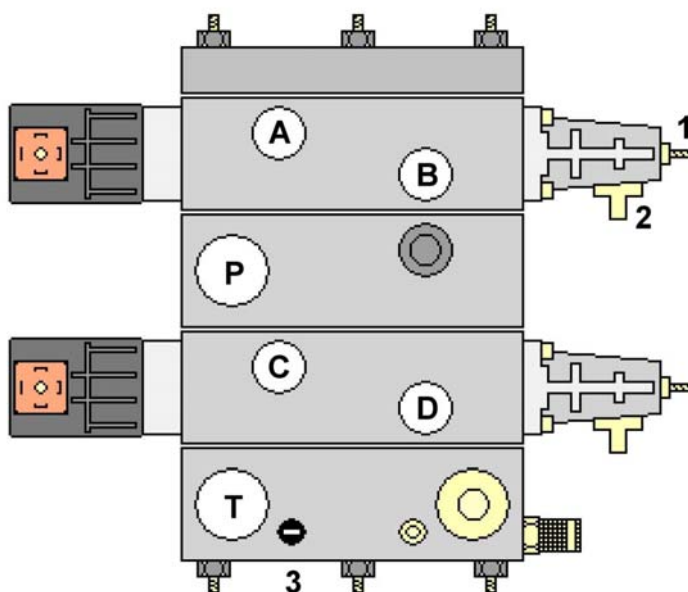

- 1) Flow Adjustment.
 - 2) Manual Override.
 - 3) Pressure Relief Valve (200 bar).
- A) Flow for Tool (regulated).
B) N/A
C) Cutting Angle
D) Cutting Angle
P) Pressure (flow from pump).
T) Tank Connection
(pressureless + T from motor).

Splitter Valve

- P) Pressure from pump (Max. 150L/min).
- R) Regulated oil flow (Max. 90L/min).
- T1) Return from motor.
- T) Tank connection.
- M) Manometer test plug.

P / R / T1 / T = 3/4" Thread
 M = 1/4" Thread

TS3300
 50 L/min
 150 bar

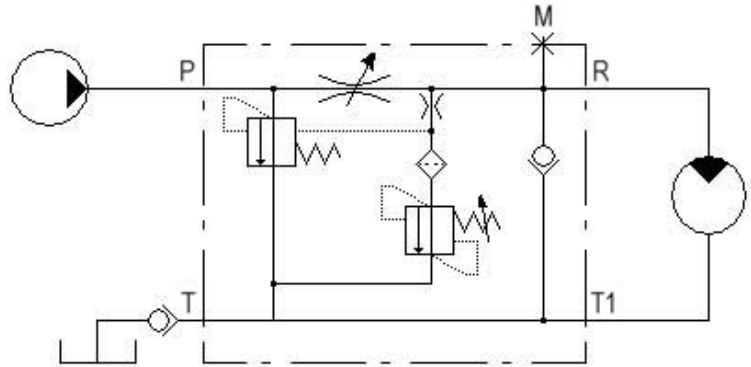
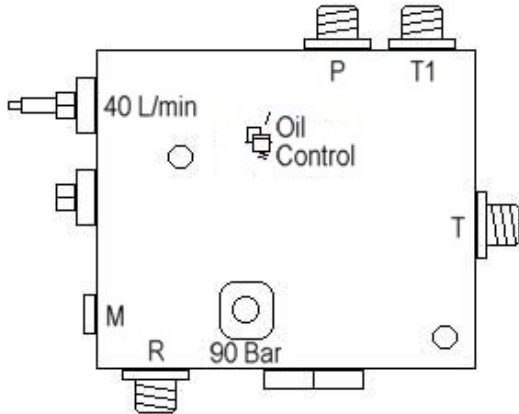

Electrical Diagram

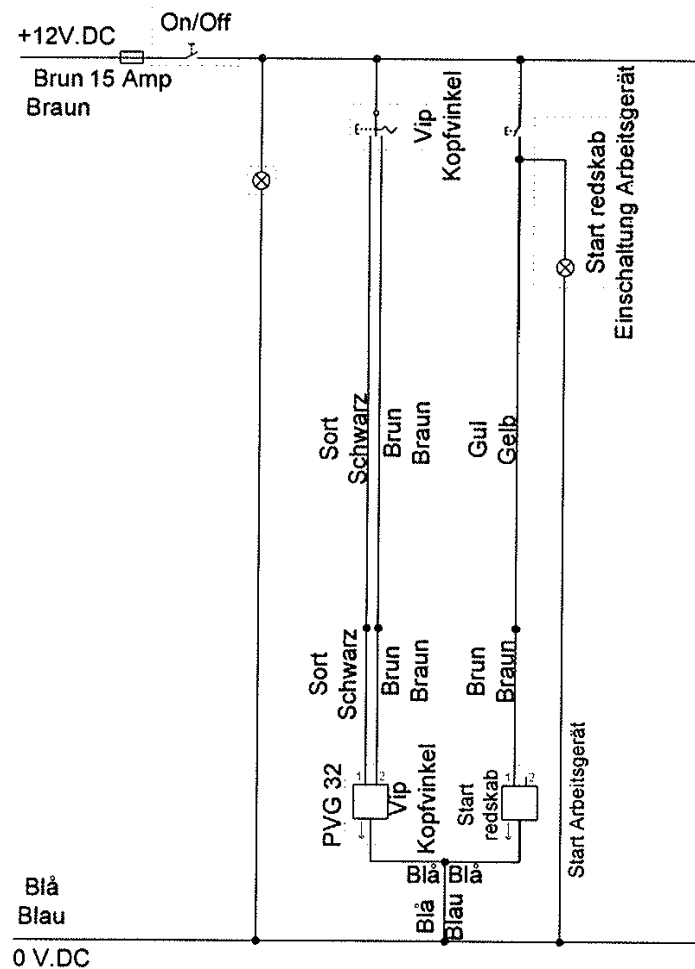

Hydraulic Diagrams

Break-back 40-50 bar

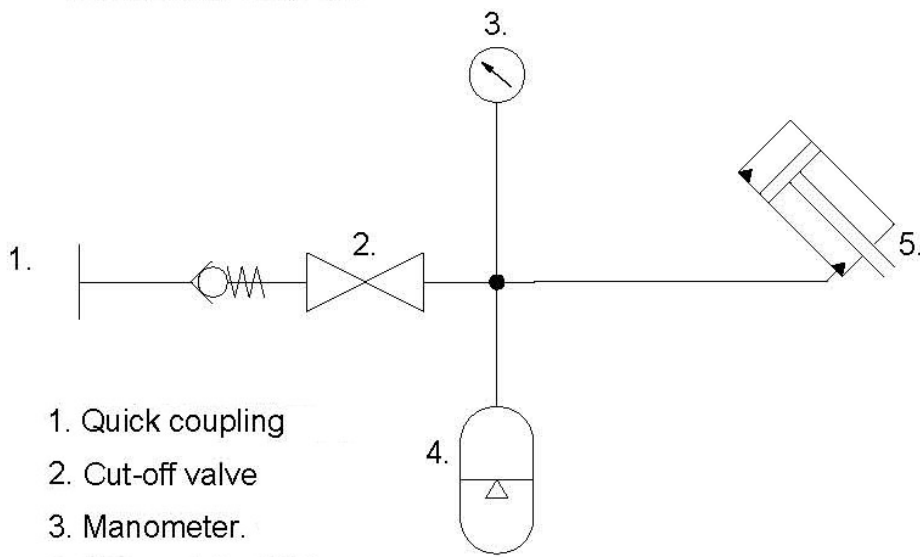

- 1. Quick coupling
- 2. Cut-off valve
- 3. Manometer.
- 4. Accumulator 32 bar
- 5. Break back ram

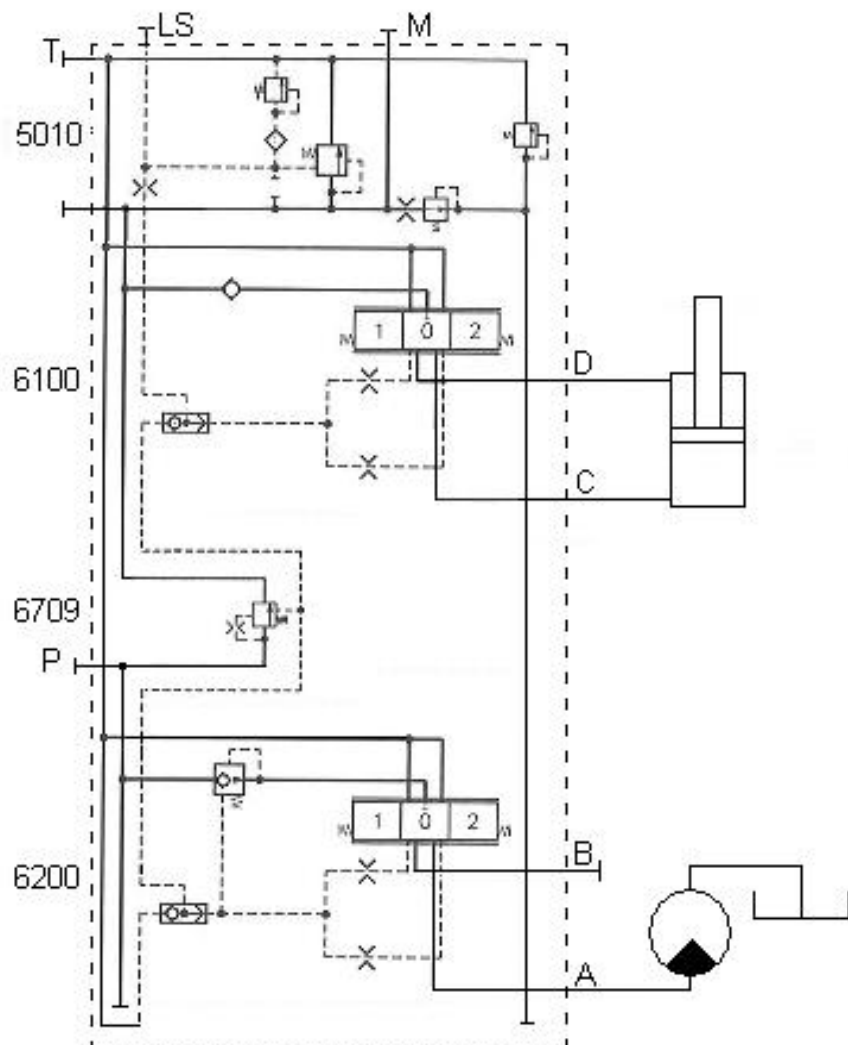

TS3300 MAINTENANCE

Lubrication

Grease the lubrication points on machine on the following basis;

- Daily prior to use.
- Always prior to storage.
- Always after it has been washed.

NOTE: Never use grease that contains Molybdenum Disulfide on nylon bushes.

Hydraulic Hoses

Inspect hydraulic hoses and fittings on a daily basis prior to using the machine; ensure they are free from damage or leaks and that the hoses are not rubbing on machine components. Any damaged hoses or fittings should be repaired or replaced immediately.

Run new hoses alongside the old ones prior to removal to ensure the correct routing is retained. When replacing a hose avoid twisting it, use 2 spanners to tighten it.

Ensure hoses bend with machine movements and that they do not twist or strain.

All hose connections are of a 'soft seal' type and should only be turned a further 1/2 turn more than hand tight in order to be leak-proof (*see table below*).

BSP (size)	Nm	
	1/4"	24 Nm
3/8"	33 Nm	24 lbs/ft
1/2"	44 Nm	35 lbs/ft
3/4"	84 Nm	62 lbs/ft
1"	115 Nm	85 lbs/ft

Oil Supply

Check oil level in the tank each day prior to starting work - it is good practice to constantly keep an eye on the sight glass level as a ruptured pipeline can empty a system within minutes; a pump or motor that runs out of oil will be damaged beyond repair very quickly.

The oil must be changed if there are signs that it is contaminated (discolored).

Ensure cleanliness when replacing or topping up the oil by;

- Carefully cleaning around the filler neck prior to opening.
- Always using clean containers for refilling the system.
- Regular inspection of the filtration system.
- Never letting the oil level fall below the level in the sight glass.

Check daily for all hydraulic connections and fittings are in good condition. Any defect or leak must be immediately repaired, it is part of the daily maintenance that will reduce costs and prolong machine life.

If fittings require retightening always use 2 spanners and avoid over tightening. If the fitting continues to leak, replace it.

Regular Maintenance Tasks

After every 4 hours of use the following maintenance task should be observed;

- Check bolts for tightness and – *retighten if required*.
- Check valve block, hoses and fittings for signs of leaks – *retighten or replace seals if required*.
- Bolts and bushes should be greased and retightened.

Bolts and Bushes

All major pivot points are equipped with replaceable bushings, if they show signs of wear, replace them. **NOTE: Never use grease that contains Molybdenum Disulfide on nylon bushes.**

Machine Storage

Before the machine is placed into storage, it should be thoroughly washed. Remove all traces of grass, leaves and dirt.

Take care if using high pressure jet hoses or steam cleaners as these can quickly damage paintwork and decals. Remove all cleaning products thoroughly to avoid them from staining or damaging the paint.

Grease lubrication points until fresh grease comes out.

Where applicable, rotor drive belts should be loosened to remove tension and 'relax' the belts.

Ideally, the machine should be stored in a clean dry environment where it is protected from the elements; if the machine has to be stored outside it is advisable to keep it covered over to protect it from rain and sunlight. Control units should be stored clear of the ground and protected from the damp. It is recommended that canvas tarpaulin or similar coverings are used to cover the machine rather than plastic sheeting which would harbor condensation and promote rapid corrosion.



WARNING Blade guard must be fitted when the machine is in storage or parked.

TROUBLESHOOTING GUIDE

Problem	Possible Cause	Solution
Valve or motor leak.	Oil pressure too high. Hose incorrectly fitted or loose.	Check pressure. Replace gasket. Refit and tighten correctly.
Overheating.	Tool speed incorrect. Incorrect oil level. Wrong oil type. Blades clogged. Air temperature too high.	Check PTO speed. Check oil level. Empty tank and fill with correct oil. Stop machine and clear blades. Reduce operating speed/install fan.
Electrical failure.	Wrong supply from tractor. Contacts exposed to water.	Check fuse and supply from tractor. Always store protected from water.
Hydraulic failure.	Oil level too low. Pressure hose kinked. Oil leak in pressure hose. Oil pump suction filter blocked.	Top up oil to correct level. Check pump rotates / check hoses. Check machine for leaks. Replace filter element.
Irregular arm movements.	Broken spring in the PVG valve. Defective ram seals.	Check spring – <i>replace if required.</i> Check seals – <i>replace if required.</i>
Electric valve not responding.	Faulty wiring. Dirt in valve. Valve stuck. Insufficient voltage.	Check wiring and switches. Check and clean valve. Replace valve. Check for bad connection.

MACHINE DISPOSAL

At the end of its working life disposal of this machine and any component parts must be performed in an environmentally friendly manner respecting the current laws relating to the subject. Materials forming the machine that must undergo differentiated division and disposal are;

- Steel
- Rubber
- Plastic

**Parts Manual for
TWOSE TREESAWS
TS1401 / TS1601 / TS2001 / TS2401
TELEHANDLER CARRIAGE
TS3300**

TREESA W TS1401 – MAIN ASSEMBLY

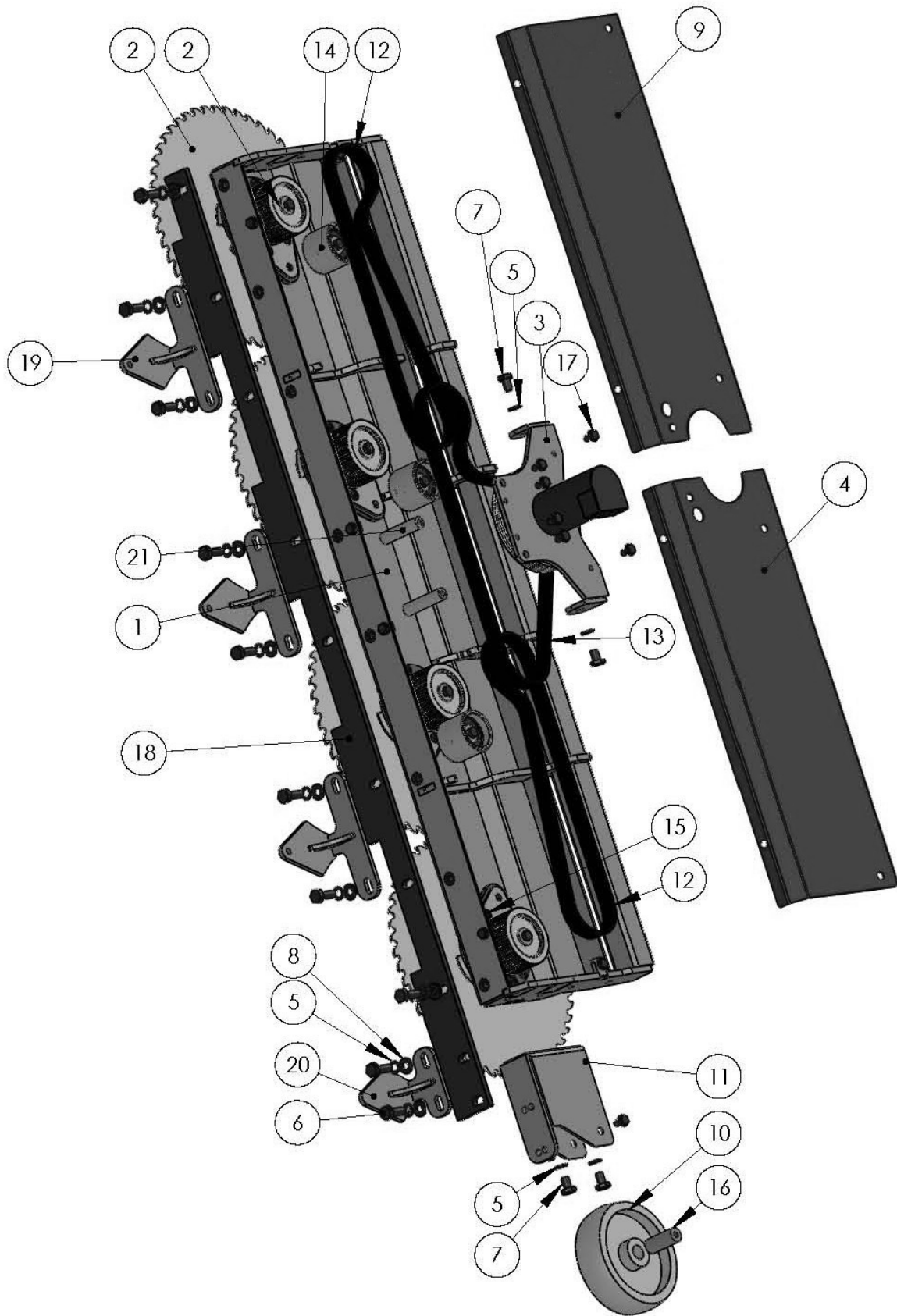

TREESAW TS1401 – MAIN ASSEMBLY

REF.	QTY.	PART No.	DESCRIPTION
		1070931	TREESAW TS1401 - MAIN ASSEMBLY
1	1	1070155	FRAME
2	4	1070156	BLADE ASSEMBLY
3	1	1070157	MOTOR PLATE ASSEMBLY
4	1	1070158	LH DECK COVER PLATE
5	14	1070159	LOCK WASHER
6	10	1070160	BOLT
7	4	1070161	BOLT
8	10	1070162	WASHER
9	1	1070163	RH DECK COVER PLATE
10	1	1070164	WHEEL
11	1	1070165	WHEEL BRACKET
12	2	1070166	BELT (OUTER)
13	1	1070167	BELT (CENTRE)
14	3	1070175	TENSIONER ASSEMBLY
15	16	1070168	ALLEN SCREW
16	1	1070169	WHEEL BUSHING
17	14	1070170	BOLT
18	1	1070171	FRONT STRIP
19	3	1070172	BRANCH DEFLECTOR (LONG)
20	1	1070173	BRANCH DEFLECTOR (SHORT)
21	2	1070174	SPACER PIECE

TREESAW TS1401 – BLADE ASSEMBLY

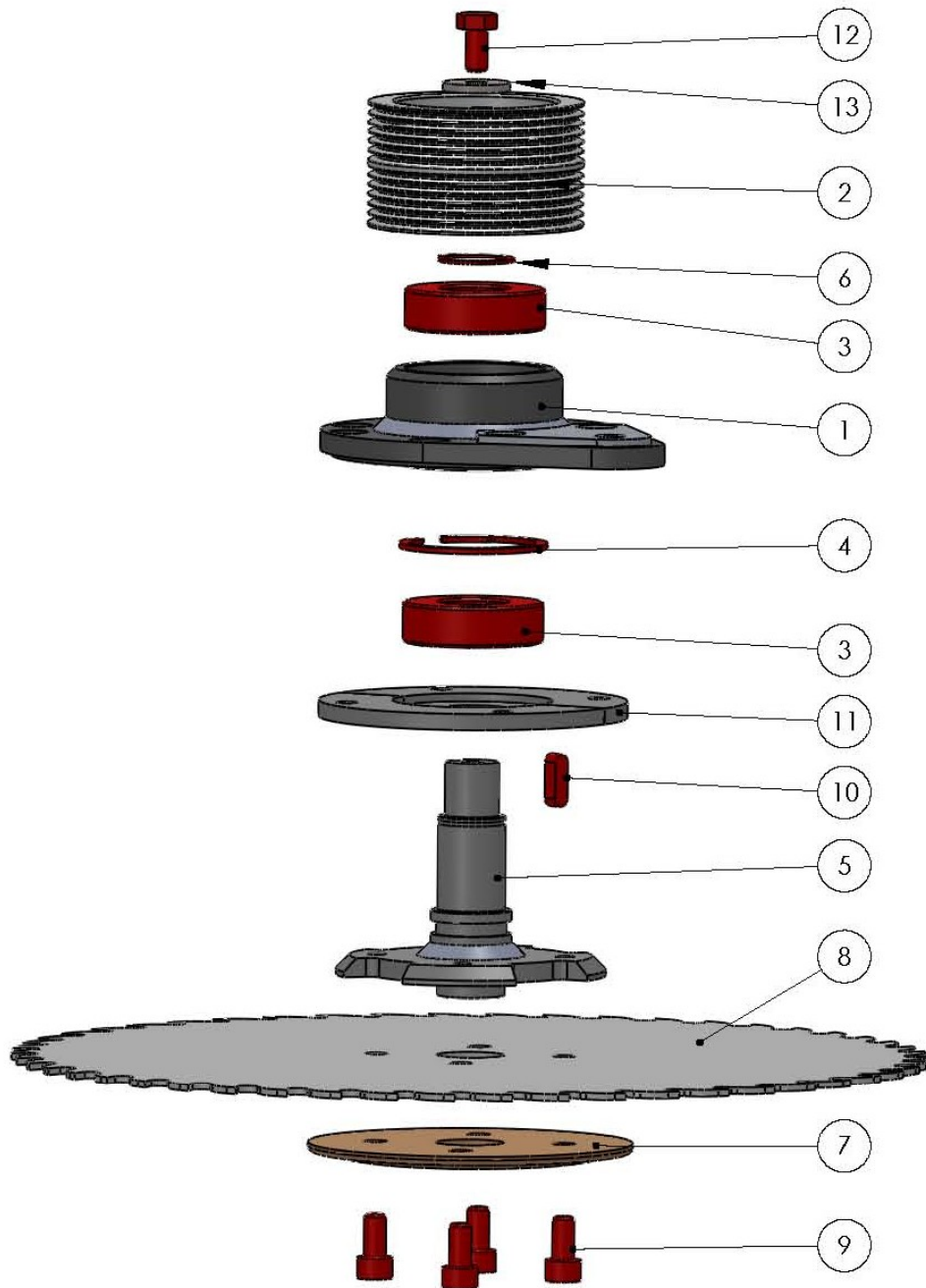

TREESAW TS1401 – BLADE ASSEMBLY

REF.	QTY.	PART No.	DESCRIPTION
		1070156	TREESAW 1401 - BLADE ASSEMBLY
1	1	1070176	BEARING HOUSING
2	1	1070177	DRIVE PULLEY
3	2	1070178	BEARING
4	1	1070179	CIRCLIP
5	1	1070180	BLADE SHAFT
6	1	1070181	CIRCLIP
7	1	1070182	BLADE PLATE
8	1	1070183	BLADE
9	4	1070168	BOLT
10	1	1070184	KEY
11	2	1070185	SPACER PLATE
12	1	1070186	BOLT
13	1	1070187	WASHER

TREESAW TS1401 – MOTOR PLATE ASSEMBLY

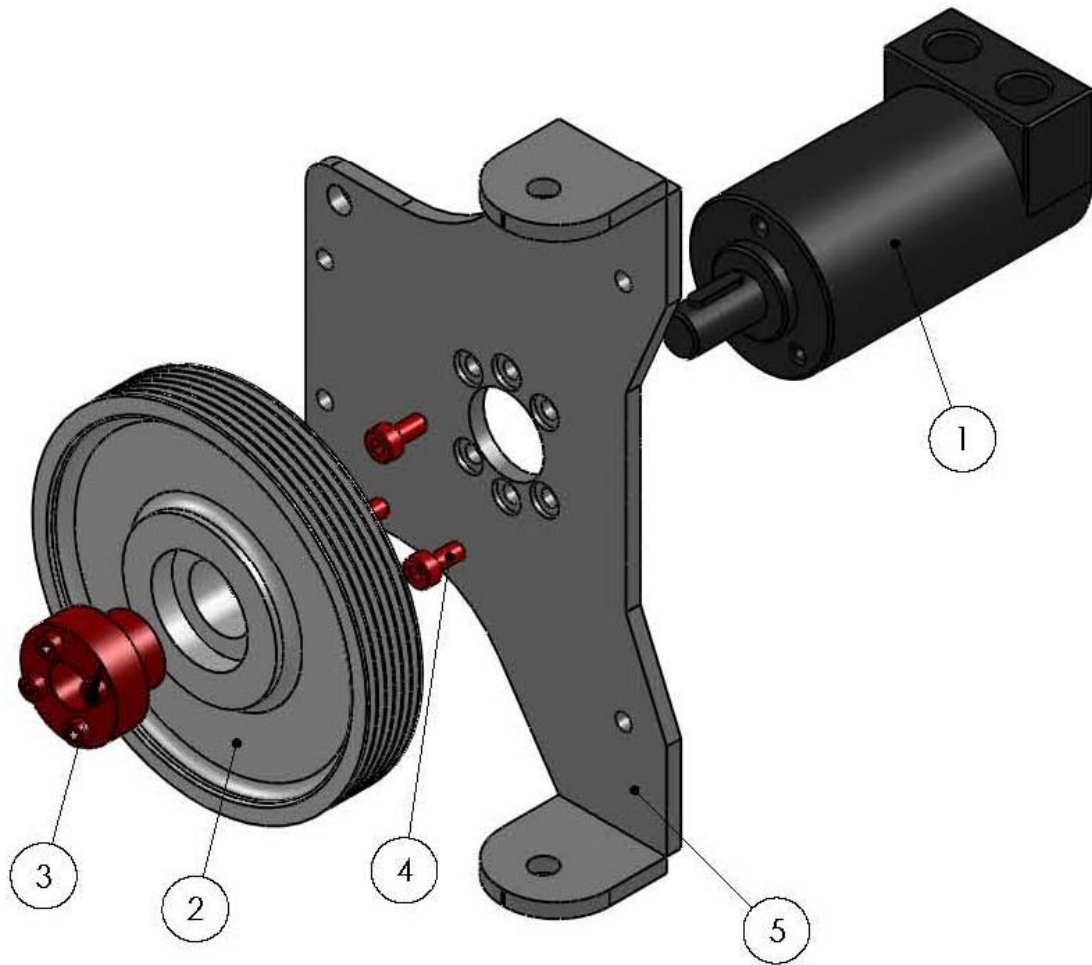

REF.	QTY.	PART No.	DESCRIPTION
		1070157	TREESAW 1401 - MOTOR PLATE ASSEMBLY
1	1	1070188	HYDRAULIC MOTOR
2	1	1070189	BELT PULLEY
3	1	1070190	ROTA-FIX
4	3	1070191	ALLEN SCREW
5	1	1070192	MOTOR PLATE

TREESAW TS1401 – TENSIONER ASSEMBLY

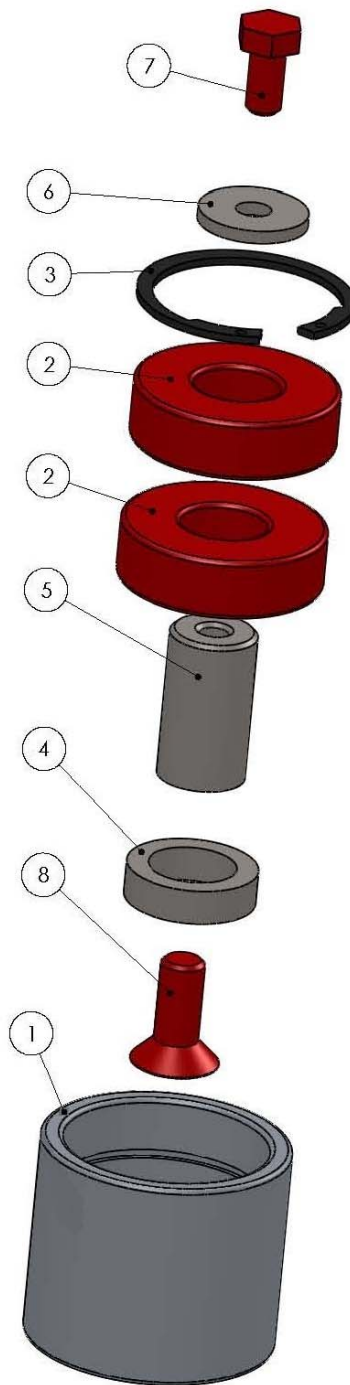

REF.	QTY.	PART No.	DESCRIPTION
		1070175	TREESAW 1401 - TENSIONER ASSEMBLY
1	1	1070193	TENSIONER PULLEY
2	2	1070194	BEARING
3	1	1070195	CIRCLIP
4	1	1070196	SEAL
5	1	1070197	SPACER
6	1	1070187	WASHER
7	1	1070186	BOLT
8	1	1070198	SCREW

TREESA W TS1601 – MAIN ASSEMBLY

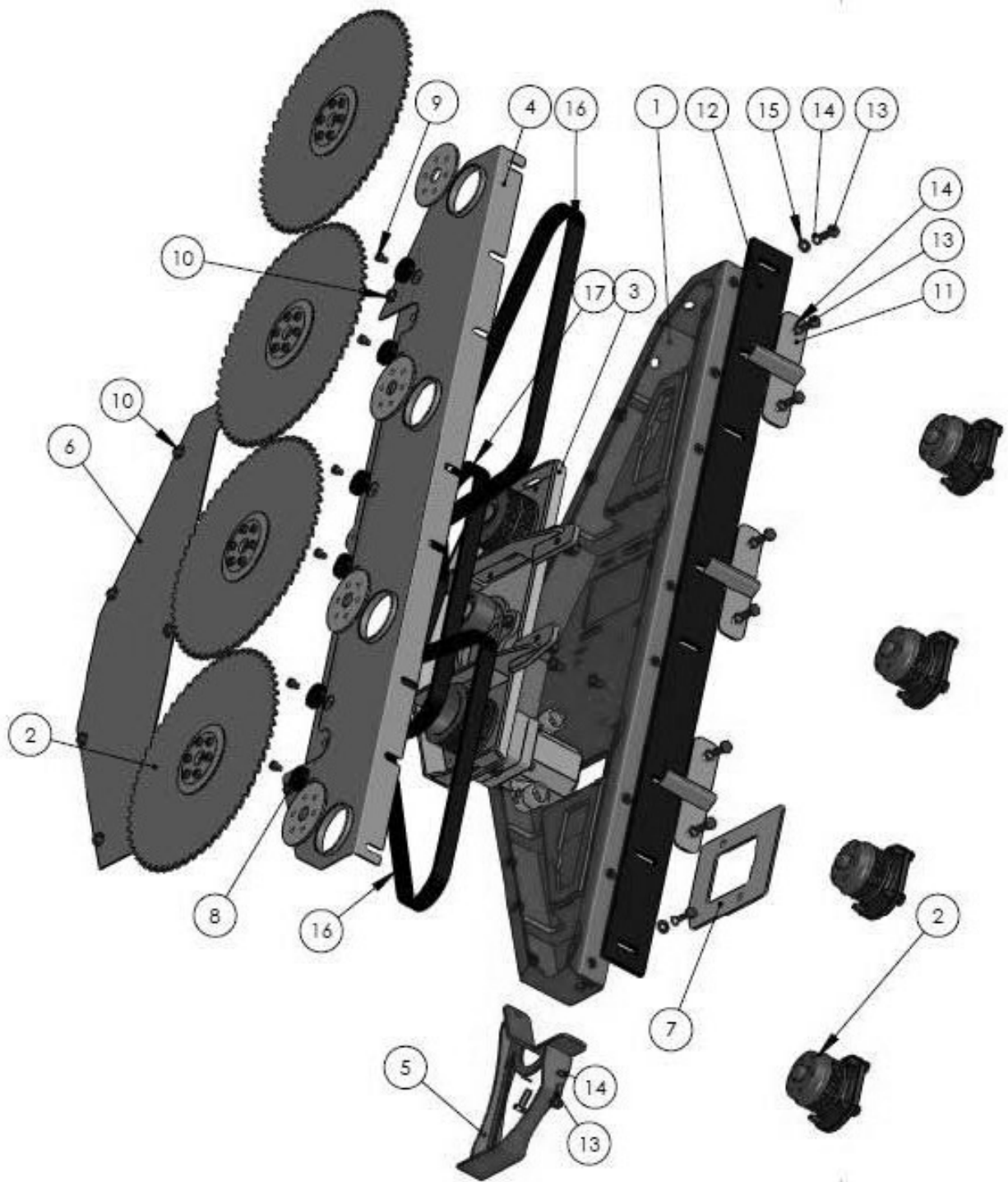

TREESAW TS1601 – MAIN ASSEMBLY

REF.	QTY.	PART No.	DESCRIPTION
			TREESAW TS1601 - MAIN ASSEMBLY
1	1	1070072	FRAME
2	<i>See blade unit page</i>		DRIVE PULLEY ASSEMBLY
3	1	1070088	DRIVE BOX
4	1	1070073	DECK
5	1	1070074	SKID
6	1	1070075	BELT COVER
7	1	1070076	PLATE
8	6	1070077	RUBBER BLOCK
9	6	1070078	BOLT
10	9	1070079	BOLT
11	3	1070080	BRANCH DEFLECTOR
12	1	1070081	PLASTIC STRIP
13	11	1070082	BOLT
14	11	1070083	WASHER
15	2	1070084	WASHER
16	2	1070085	BELT (LONG)
17	1	1070086	BELT (SHORT)
18	1	1070087 *	PROTECTION

* *not illustrated*

TREESAW TS1601 – DRIVE ASSEMBLY

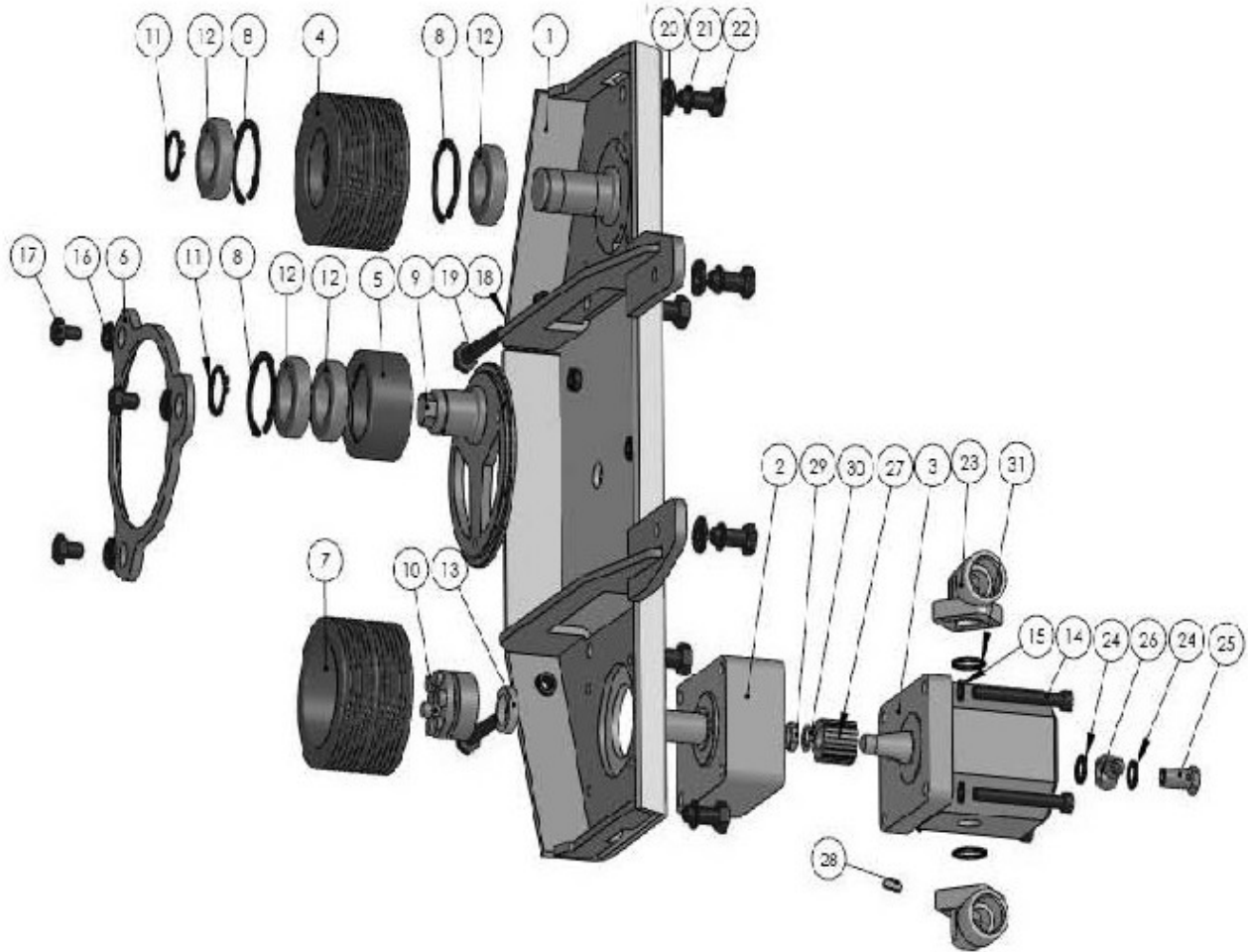

TREESAW TS1601 – DRIVE ASSEMBLY

REF.	QTY.	PART No.	DESCRIPTION
TREESAW TS1601 - DRIVE ASSEMBLY			
1	1	1070088	DRIVE BOX
2	1	1070089	DRIVE SUPPORT
3	1	1070090	MOTOR (17cc)
4	1	1070091	BELT PULLEY
5	1	1070092	IDLER PULLEY
6	1	1070093	ADJUSTER RING
7	1	1070094	DRIVE PULLEY
8	3	1070095	CIRCLIP
9	1	1070096	ADJUSTMENT WHEEL
10	1	1070097	EASY LOCK BUSH
11	2	1070098	CIRCLIP
12	4	1070099	BEARING
13	1	1070100	ADJUSTER
14	4	1070101	BOLT
15	4	1070064	WASHER
16	3	1070084	WASHER
17	3	1070102	BOLT
18	2	1070103	NUT
19	2	1070104	BOLT
20	4	1070105	WASHER
21	6	1070106	WASHER
22	6	1070107	BOLT
23	2	1070108	FLANGE CONNECTOR
24	2	1070109	WASHER
25	1	1070110	BANJO BOLT
26	1	1070111	BANJO
27	1	1070112	SPLINED COUPLING
28	1	1070113	SOCKET
29	1	1070114	NUT
30	1	1070115	WASHER
31	2	1070116	O RING

TREESA W TS1601 – BLADE UNIT ASSEMBLY

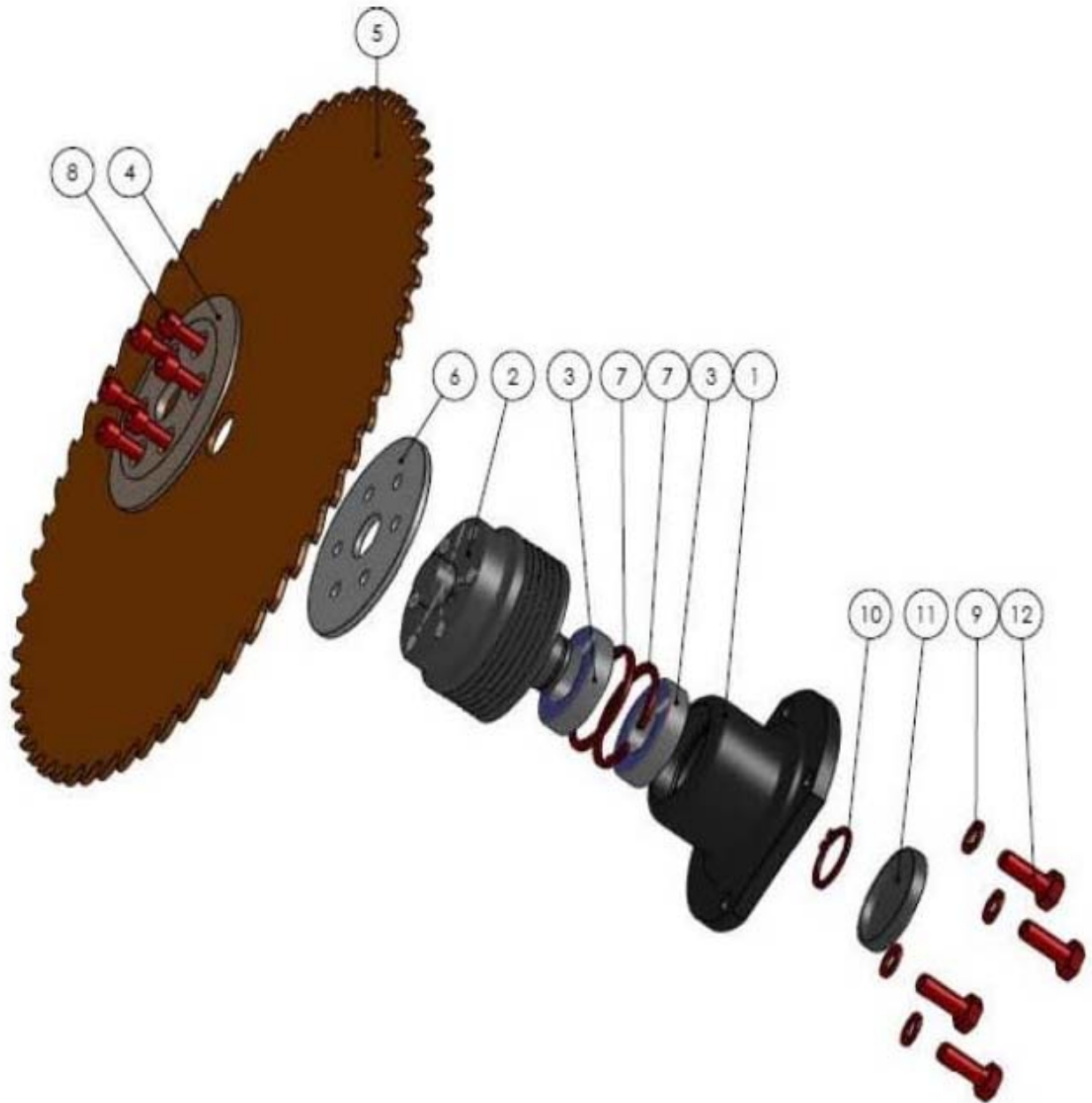

TREESAW TS1601 – BLADE UNIT ASSEMBLY

REF.	QTY.	PART No.	DESCRIPTION
			TREESAW TS1601 - BLADE ASSEMBLY
1	1	1070117	BEARING HOUSING
2	1	1070118	DRIVE PULLEY
3	2	1070099	BEARING
4	1	1070119	OUTER BLADE PLATE
5	1	1070001	BLADE
6	1	1070120	INNER BLADE PLATE
7	2	1070095	CIRCLIP
8	6	1070121	SETSCREW
9	4	1070083	WASHER
10	1	1070098	CIRCLIP
11	1	1070122	COVER PLATE
12	4	1070082	BOLT

TREESAW TS2001/TS2401 – MAINFRAME (1)

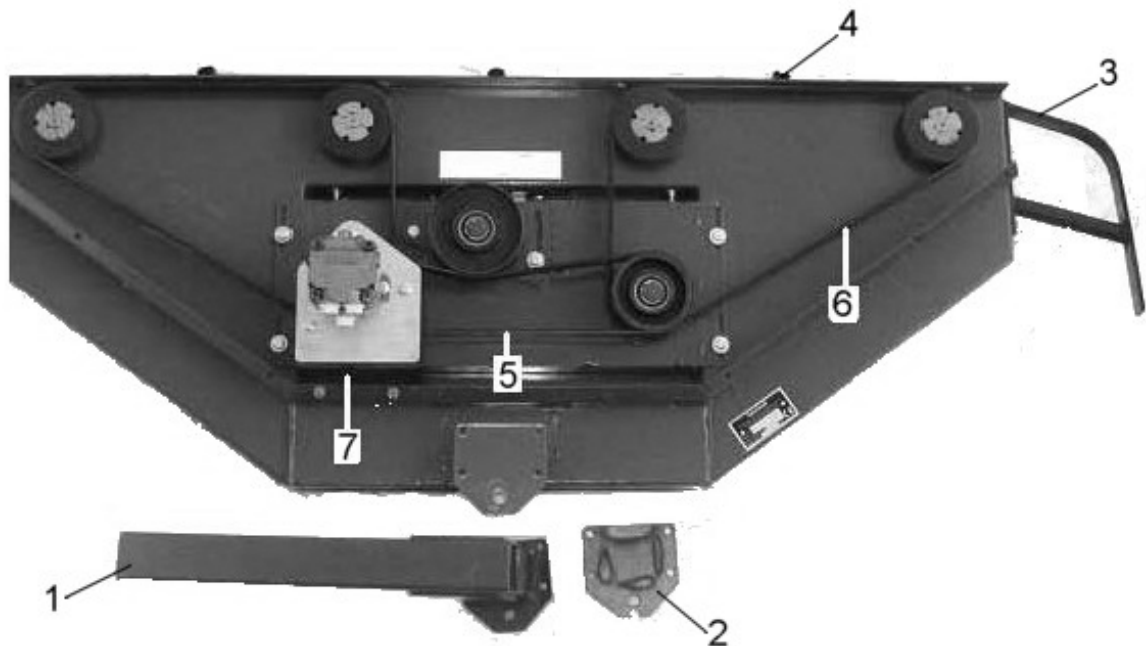

REF.	QTY.	PART No.	DESCRIPTION
TREESAW TS2001/TS2401 - MAINFRAME (1)			
1	1	1070005	MOUNTING ARM - <i>Treesaw TS2001</i>
	1	1070006	MOUNTING ARM - <i>Treesaw TS2401</i>
2	1	1070007	MOUNTING PLATE
3	1	1070010	SKID (LH USE) - <i>Treesaw TS2001</i>
	1	1070011	SKID (LH USE) - <i>Treesaw TS2401</i>
	1	1070008	SKID (RH USE) - <i>Treesaw TS2001</i>
	1	1070009	SKID (RH USE) - <i>Treesaw TS2401</i>
4	3	1070012	BRANCH CARRIER - <i>Treesaw TS2001</i>
	3	1070013	BRANCH CARRIER - <i>Treesaw TS2401</i>
5	1	1070014	BELT (SHORT) - <i>Treesaw TS2001</i>
	1	1070015	BELT (SHORT) - <i>Treesaw TS2401</i>
6	2	1070016	BELT (LONG) - <i>Treesaw TS2001</i>
	2	1070017	BELT (LONG) - <i>Treesaw TS2401</i>
7	1	1070018	RUBBER PROTECTION

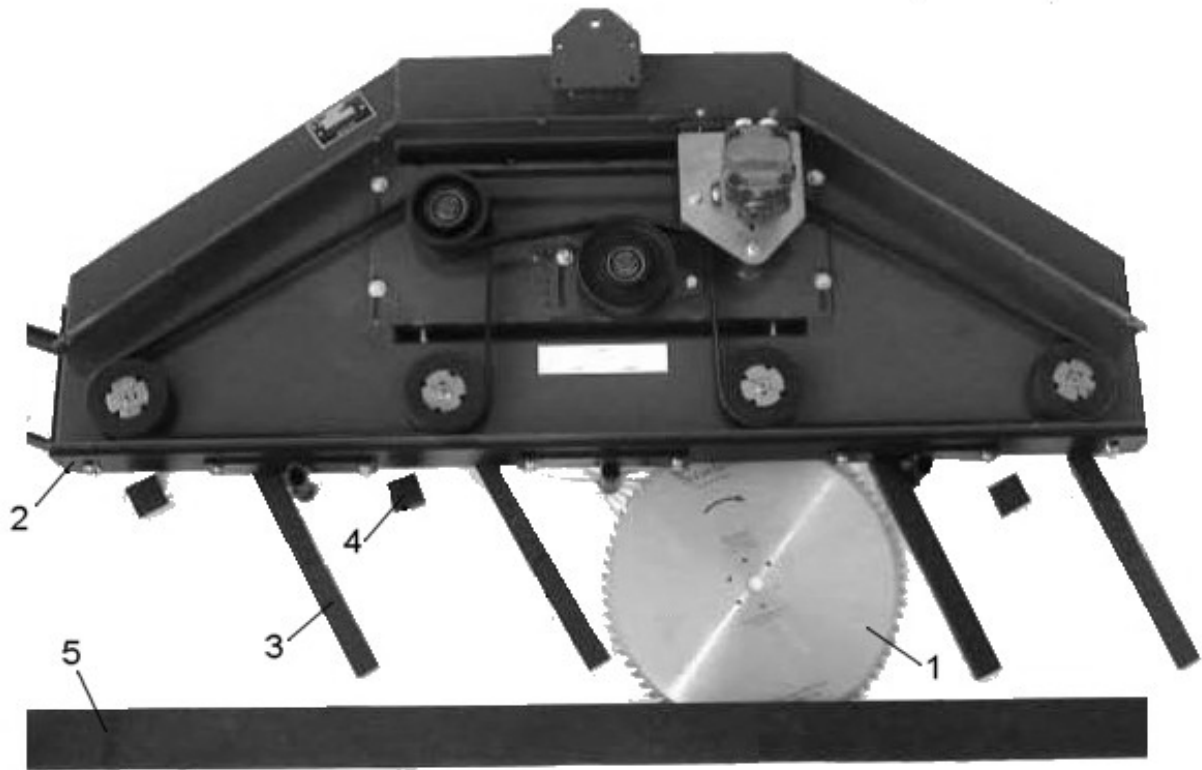

REF.	QTY.	PART No.	DESCRIPTION
TREESAW TS2001/TS2401 - MAINFRAME (2)			
1	4	1070002	BLADE - <i>Treesaw TS2001</i>
	4	1070003	BLADE - <i>Treesaw TS2401</i>
2	1	1070019	PLASTIC STRIP - <i>Treesaw TS2001</i>
	1	1070020	PLASTIC STRIP - <i>Treesaw TS2401</i>
3	4	1070021	WEAR PLATE (LONG) - <i>Treesaw TS2401</i>
4	4	1070022	WEAR PLATE (SHORT)
5	1	1070023	TRANSPORT PROTECTOR

TREESAW TS2001/TS2401 – BLADE SHAFT

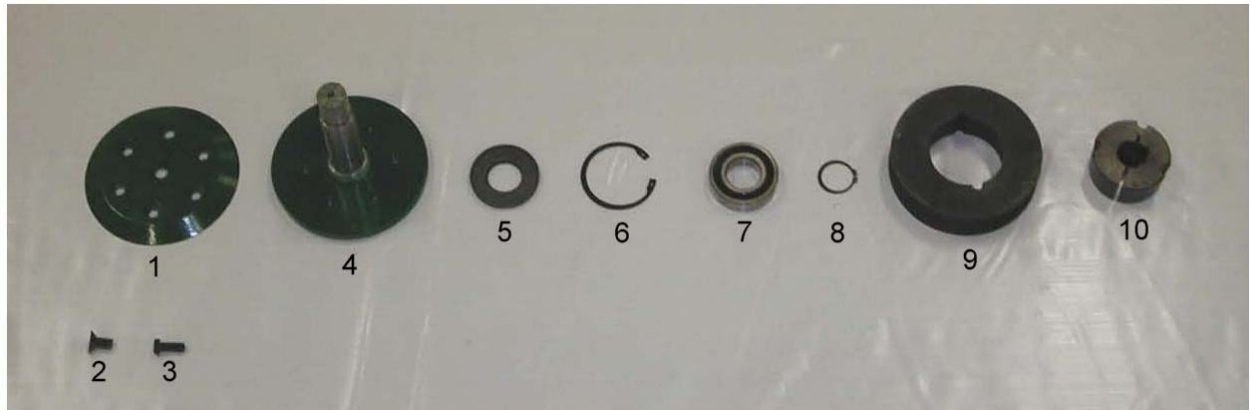

REF.	QTY.	PART No.	DESCRIPTION
TREESAW TS2001/TS2401 - BLADE SHAFT			
1	4	1070024	MOUNTING PLATE
2	4	1070025	CENTRE BOLT (CONICAL) - <i>Treesaw TS2001</i>
	4	1070026	CENTRE BOLT (ALLEN) - <i>Treesaw TS2001/TS2401</i>
3	24	1070027	BOLT
4	4	1070028	BLADE SHAFT - <i>Treesaw TS2001</i>
	4	1070029	BLADE SHAFT - <i>Treesaw TS2401</i>
5	4	1070030	SEAL - <i>Treesaw TS2001</i>
	4	1070031	SEAL - <i>Treesaw TS2401</i>
6	8	1070032	CIRCLIP - <i>Treesaw TS2001</i>
	8	1070033	CIRCLIP - <i>Treesaw TS2401</i>
7	8	1070034	BEARING - <i>Treesaw TS2001</i>
	8	1070035	BEARING - <i>Treesaw TS2401</i>
8	4	1070036	CIRCLIP - <i>Treesaw TS2001</i>
	4	1070037	CIRCLIP - <i>Treesaw TS2401</i>
9	4	1070038	PULLEY - <i>Treesaw TS2001</i>
	4	1070039	PULLEY - <i>Treesaw TS2401</i>
10	4	1070040	TAPERLOCK - <i>Treesaw TS2001</i>
	4	1070041	TAPERLOCK - <i>Treesaw TS2401</i>

NOTE: Quantities stated are per machine

TREESAW TS2001/TS2401 – ADJUSTING SYSTEM

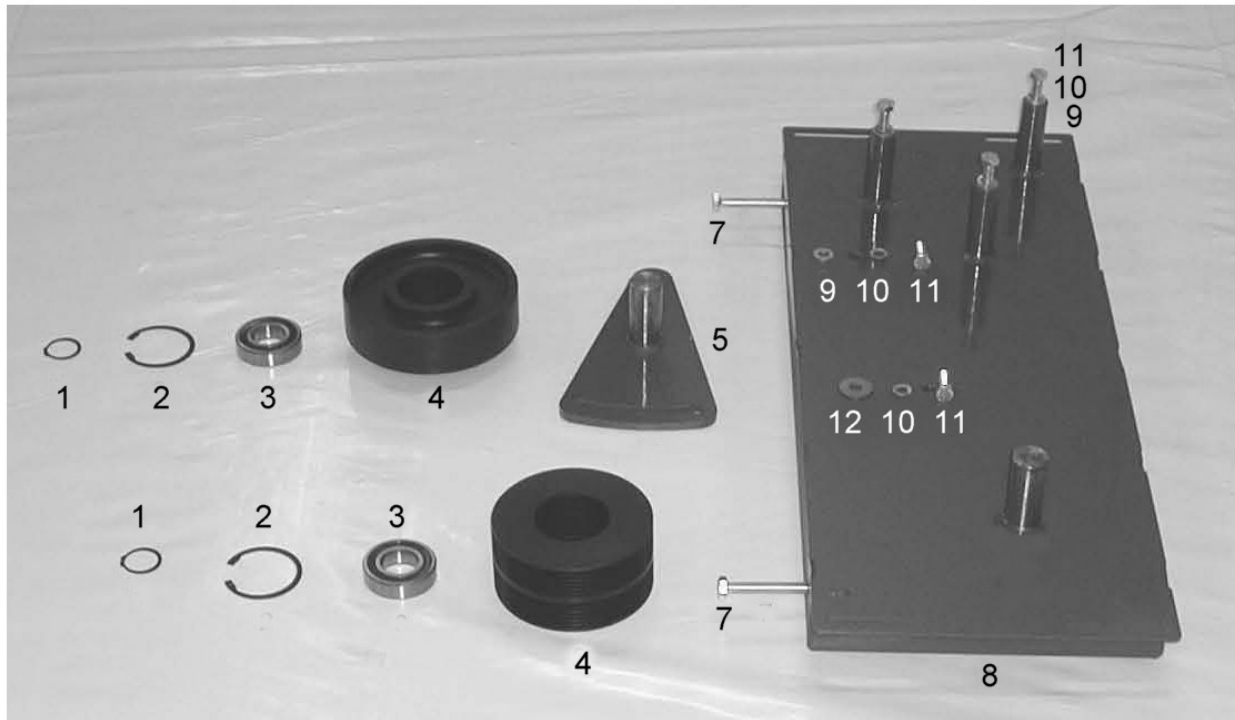

REF.	QTY.	PART No.	DESCRIPTION
TREESAW TS2001/TS2401 - ADJUSTER SYSTEM			
1	2	1070036	CIRCLIP
2	4	1070032	CIRCLIP
3	4	1070034	BEARING
4	1	1070042	TENSION PULLEY - <i>Treesaw TS2001</i>
	1	1070043	TENSION PULLEY - <i>Treesaw TS2401</i>
5	1	1070044	ADJUSTER PLATE - <i>Treesaw TS2001</i>
	1	1070045	ADJUSTER PLATE - <i>Treesaw TS2401</i>
6	1	1070046	DOUBLE PULLEY - <i>Treesaw TS2001</i>
	1	1070047	DOUBLE PULLEY - <i>Treesaw TS2401</i>
7	2	1070048	ADJUSTMENT BOLT
8	1	1070051	ADJUSTMENT BOX - <i>Treesaw TS2001 LH</i>
	1	1070049	ADJUSTMENT BOX - <i>Treesaw TS2001 RH</i>
	1	1070052	ADJUSTMENT BOX - <i>Treesaw TS2401 LH</i>
	1	1070050	ADJUSTMENT BOX - <i>Treesaw TS2401 RH</i>
9	4	1070053	WASHER
10	5	1070054	SPRING WASHER
11	5	1070055	BOLT
12	1	1070056	WASHER

NOTE: Quantities stated are per machine

TREESAW TS2001/TS2401 – PISTON MOTOR

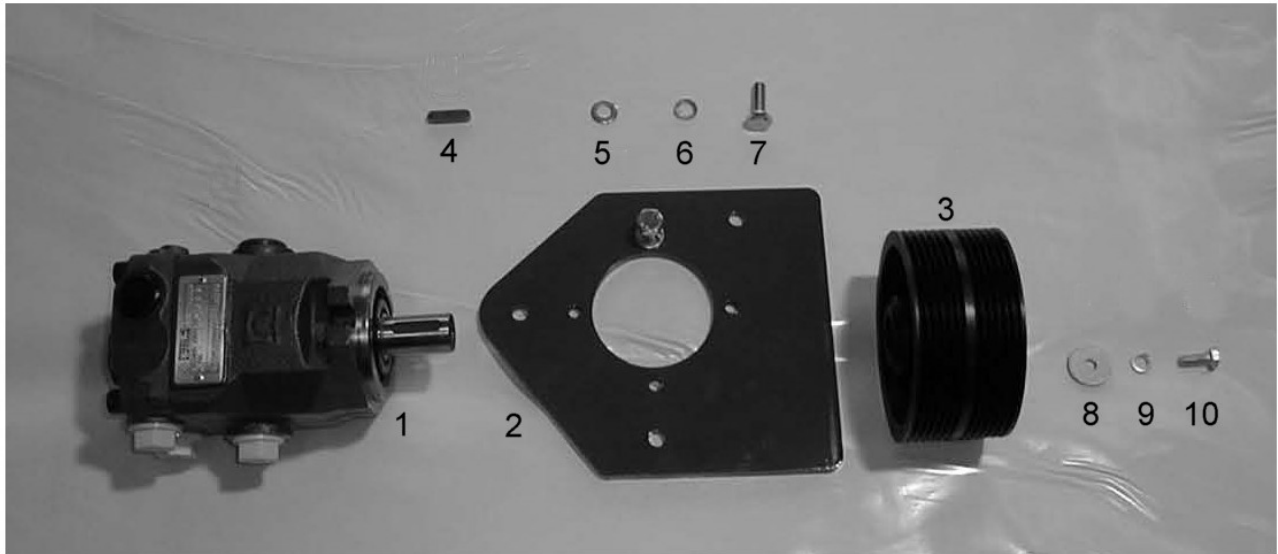

REF.	QTY.	PART No.	DESCRIPTION
			TREESAW TS2000/TS2400 - PISTON MOTOR
1	1	1070058	PISTON MOTOR (28cc)
	1	1070057	PISTON MOTOR (15cc) - <i>Telehandler builds only</i>
2	1	1070061	MOUNTING PLATE - <i>Treesaw TS2001</i>
	1	1070062	MOUNTING PLATE - <i>Treesaw TS2401</i>
3	1	1070063	PULLEY - <i>Treesaw TS2001</i>
	1	1070064	PULLEY - <i>Treesaw TS2401</i>
4	1	1070065	KEY
5	2	1070053	WASHER
6	2	1070054	SPRING WASHER
7	2	1070055	BOLT
8	1	1070066	WASHER
9	1	1070067	SPRING WASHER
10	1	1070068	BOLT
11	2	1070069	3/4" HYDRAULIC HOSE
12	1	1070070	3/8" HYDRAULIC HOSE
13	1	1070071	HOSE PROTECTION (1600mm)
		1070059	SEAL & O RING (Output Shaft)
		1070060	SEAL KIT COMPLETE

TREESAW DECALS



1



2



3



4



5



6

TREESAW

7

REF.	QTY.	PART No.	DESCRIPTION
MULTISAW - DECALS			
1	1	1070123	DANGER ROTATING PARTS
2	1	1070124	KEEP DISTANCE FROM ELECTRIC
3	1	1070125	KEEP SAFE DISTANCE FROM MACHINE
4	1	1070126	CHECK BOLT TIGHTNESS (8 HOURS)
5	1	1070127	READ THE BOOK
6	1	1290937	DECAL - TWOSE
7	2	1290944	DECAL - TREESAW

TS3300 LOADER CARRIAGE

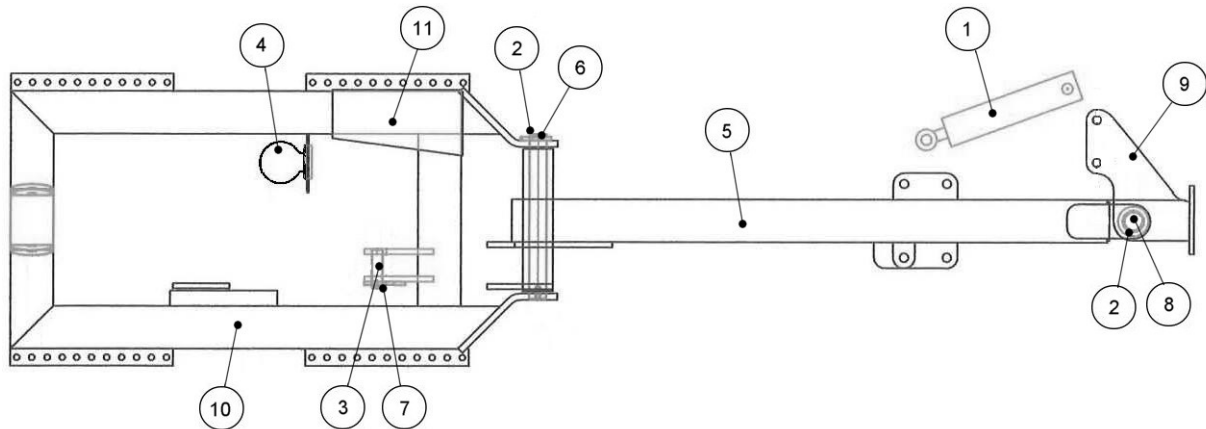

REF.	QTY.	PART No.	DESCRIPTION
LOADER CARRIAGE FOR TREESAW			
1	1	1070128	RAM
2	4	1070130	BUSH
3	1	1070131	RAM
4	1	1070132	ACCUMULATOR
5	1	1070133	ARM
6	1	1070134	PIN
7	1	1070135	PIN
8	1	1070136	PIN
9	1	1070137	BRACKET - L/H
	1	1070138	BRACKET - R/H
10	1	1070139	MAINFRAME
11	1	1070140	GUARD
12	1	1070129	TOP LINK - <i>Not shown</i>

TS3300 LOADER CARRIAGE VALVE ASSEMBLY

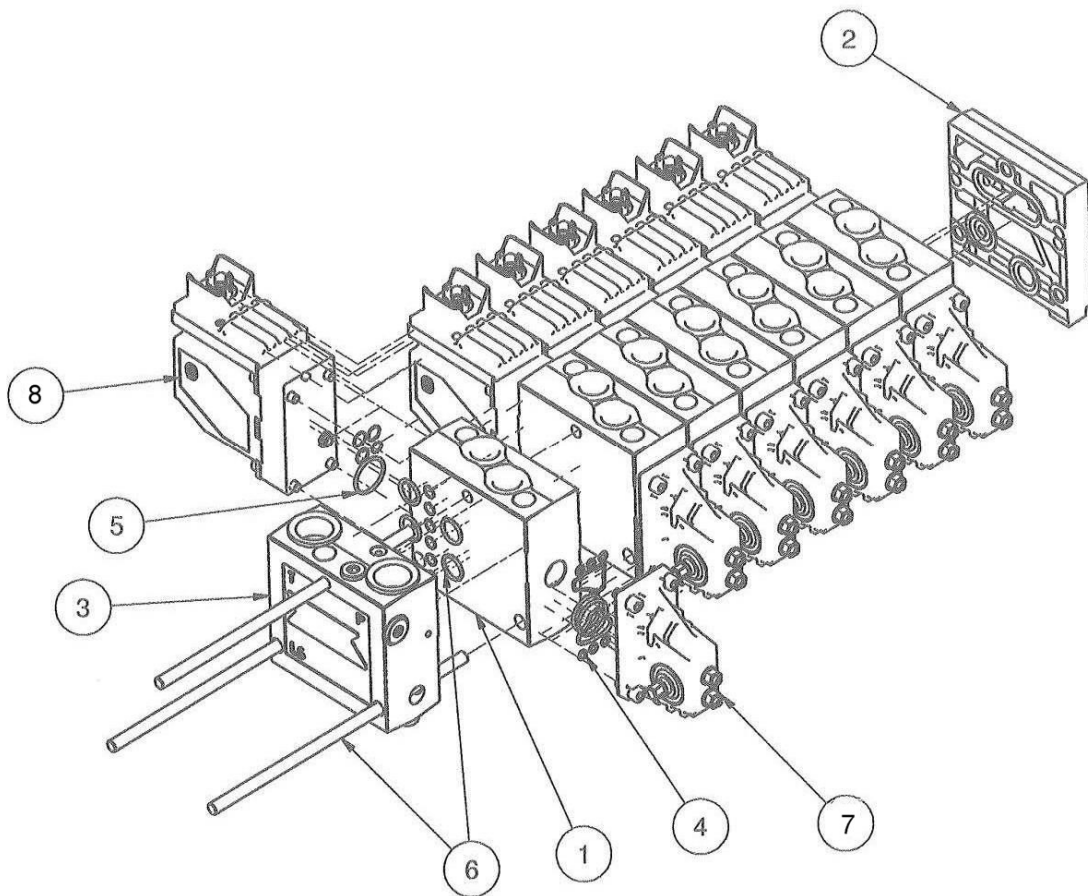

REF.	QTY.	PART No.	DESCRIPTION
			LOADER CARRIAGE VALVE
1	1	1070141	PRIORITY VALVE
2	1	1070142	MOTOR VALVE
3	1	1070143	TOOL VALVE
4	1	1070144	END COVER
5	1	1070145	END COVER
6	1	1070146	LEVER SEAL KIT
7	1	1070147	O RING KIT
8	1	1070148	SEAL KIT
9	1	1070149	LEVER HOUSING c/w SEAL KIT 1070146
10	1	1070150	ELECTRIC VALVE c/w O RING KIT 1070147
11	1	1070151	SPOOL
12	1	1070152	SPOOL

