

**TWOSE 315 & 395
FLAIL TRIMMERS
Operation & Parts Manual**

Publication 440 (8176-11-11)

IMPORTANT VERIFICATION OF WARRANTY REGISTRATION



DEALER WARRANTY INFORMATION & REGISTRATION VERIFICATION

It is imperative that the selling dealer registers this machine with Twose of Tiverton Limited before delivery to the end user – failure to do so may affect the validity of the machine warranty.

To register machines go to the Twose web site at www.twose.com, log onto 'Dealer Inside' and select the 'Machine Registration button' which can be found in the Service Section of the site. Confirm to the customer that the machine has been registered in the section below.

Should you experience any problems registering a machine in this manner please contact the Twose Office on 01884 253691.

Registration Verification

Dealer Name:
Dealer Address:
Customer Name:
Date of Warranty Registration:/...../..... Dealer Signature:

NOTE TO CUSTOMER / OWNER

Please ensure that the above section above has been completed and signed by the selling dealer to verify that your machine has been registered with Twose of Tiverton Limited.

IMPORTANT: During the initial 'bedding in' period of a new machine it is the customer's responsibility to regularly inspect all nuts, bolts and hose connections for tightness and re-tighten if required. New hydraulic connections occasionally weep small amounts of oil as the seals and joints settle in – where this occurs it can be cured by re-tightening the connection – *refer to torque settings chart below*. The tasks stated above should be performed on an hourly basis during the first day of work and at least daily thereafter as part of the machines general maintenance procedure.

TORQUE SETTINGS FOR HYDRAULIC FITTINGS

HYDRAULIC HOSE ENDS		
BSP	Setting	Metric
1/4"	18 Nm	19 mm
3/8"	31 Nm	22 mm
1/2"	49 Nm	27 mm
5/8"	60 Nm	30 mm
3/4"	80 Nm	32 mm
1"	125 Nm	41 mm
1.1/4"	190 Nm	50 mm
1.1/2"	250 Nm	55 mm
2"	420 Nm	70 mm

PORT ADAPTORS WITH BONDED SEALS		
BSP	Setting	Metric
1/4"	34 Nm	19 mm
3/8"	47 Nm	22 mm
1/2"	102 Nm	27 mm
5/8"	122 Nm	30 mm
3/4"	149 Nm	32 mm
1"	203 Nm	41 mm
1.1/4"	305 Nm	50 mm
1.1/2"	305 Nm	55 mm
2"	400 Nm	70 mm

WARRANTY POLICY

WARRANTY REGISTRATION

All machines must be registered, by the selling dealer with Twose of Tiverton Limited before delivery to the end user. On receipt of the goods it is the buyer's responsibility to check that the Verification of Warranty Registration in the Operator's Manual has been completed by the selling dealer.

1. LIMITED WARRANTIES

- 1.01. All machines supplied by Twose of Tiverton Limited are warranted to be free from defects in material and workmanship from the date of sale to the original purchaser for a period of 12 months, unless a different period is specified.
- 1.02. All spare parts supplied by Twose of Tiverton Limited are warranted to be free from defects in material and workmanship from the date of sale to the original purchaser for a period of 6 months.
- 1.03. The manufacturer will replace or repair for the purchaser any part or parts found, upon examination at its factory, to be defective under normal use and service due to defects in material or workmanship. Returned parts must be complete and unexamined.
- 1.04. This warranty does not apply to any part of the goods, which has been subjected to improper or abnormal use, negligence, alteration, modification, fitment of non-genuine parts, accident damage, or damage resulting from contact with overhead power lines, damage caused by foreign objects (e.g. stones, iron, material other than vegetation), failure due to lack of maintenance, use of incorrect oil or lubricants, contamination of the oil, or which has served its normal life. This warranty does not apply to any expendable items such as blades, flails, flap kits, skids, soil engaging parts, shields, guards, wear pads or pneumatic tyres.
- 1.05. Temporary repairs and consequential loss - i.e. oil, downtime and associated parts are specifically excluded from the warranty.
- 1.06. Warranty on hoses is limited to 12 months and does not include hoses which have suffered external damage. Only complete hoses may be returned under warranty, any which have been cut or repaired will be rejected.
- 1.07. Machines must be repaired immediately a problem arises. Continued use of the machine after a problem has occurred can result in further component failures, for which Twose of Tiverton Limited cannot be held liable, and may have safety implications.
- 1.08. Except as provided herein, no employee, agent, dealer or other person is authorised to give any warranties of any nature on behalf of Twose of Tiverton Limited.
- 1.09. For machine warranty periods in excess of 12 months the following additional exclusions shall apply:
 - 1) Hoses, external seals, exposed pipes and hydraulic tank breathers.
 - 2) Filters.
 - 3) Rubber mountings.
 - 4) External electric wiring.

N.B. Warranty cover will be invalid if any non-genuine parts have been fitted or used. Use of non-genuine parts may seriously affect the machine's performance and safety. Twose of Tiverton Limited cannot be held responsible for any failures or safety implications that arise due to the use of non-genuine parts.

2. REMEDIES AND PROCEDURES

- 2.01. The warranty is not effective unless the Selling Dealer registers the machine, via the Twose web site and confirms the registration to the purchaser by completing the Verification of Warranty Registration in the operator's manual.
- 2.02. Any fault must be reported to an authorised Twose dealer as soon as it occurs. Continued use of a machine, after a fault has occurred, can result in further component failure for which Twose of Tiverton Limited cannot be held liable.
- 2.03. Repairs should be undertaken within two days of the failure. Claims submitted for repairs undertaken more than 2 weeks after a failure has occurred, or 2 days after the parts were supplied will be rejected, unless the delay has been authorised by Twose of Tiverton Limited.
- 2.04. All claims must be submitted, by an authorised Twose Service Dealer, within 30 days of the date of repair.
- 2.05. Following examination of the claim and parts the manufacture will pay, at their discretion, for any valid claim the cost of any parts and an appropriate labour allowance if applicable.
- 2.06. The submission of a claim is not a guarantee of payment.
- 2.07. Any decision reached by Twose of Tiverton Limited is final.

3. LIMITATION OF LIABILITY

- 3.01. The manufacturer disclaims any express (except as set forth herein) and implied warranties with respect to the goods including, but not limited to, merchantability and fitness for a particular purpose.
- 3.02. The manufacturer makes no warranty as to the design, capability, capacity or suitability for use of the goods.
- 3.03. Except as provided herein, the manufacturer shall have no liability or responsibility to the purchaser or any other person or entity with respect to any liability, loss, or damage caused or alleged to be caused directly or indirectly by the goods including, but not limited to, any indirect, special, consequential, or incidental damages resulting from the use or operation of the goods or any breach of this warranty. Notwithstanding the above limitations and warranties, the manufacturer's liability hereunder for damages incurred by the purchaser or others shall not exceed the price of the goods.
- 3.04. No action arising out of any claimed breach of this warranty or transactions under this warranty may be brought more than one (1) year after the cause of the action has occurred.

4. MISCELLANEOUS

- 4.01. The manufacturer may waive compliance with any of the terms of this limited warranty, but no waiver of any terms shall be deemed to be a waiver of any other term.
- 4.02. If any provision of this limited warranty shall violate any applicable law and is held to be unenforceable, then the invalidity of such provision shall not invalidate any other provisions herein.
- 4.03. Applicable law may provide rights and benefits to the purchaser in addition to those provided herein.

EC DECLARATION OF CONFORMITY

Conforming to EEC Directive 89/392/EEC

We,

TWOSE OF TIVERTON LIMITED,
6 Chinon Court, Lower Moor Way,
Tiverton Business Park, Tiverton, Devon, EX16 6SS.

Declare under our sole responsibility that:

The product (type) *Tractor Mounted Hedgecutter/Trimmer*

.....

Product Code *T315, T393, T400, T420, T455, T460, T520, T540, T580, T585, T600*

Serial No. & Date Type

Manufactured by the above company/*

.....

(insert business name and full address if not stated above)*

Complies with the required provisions of the Directive 89/392/EEC, and AMD 91/368/EEC,
AMD 93/44/EEC, AMD 93/63/EEC and conforms with European Norm. BS EN 292.

Part 1: 1991 – Safety of Machinery – Terminology, methodology.

Part 2: 1991 – Safety of Machinery – Technical Specifications.

and other national standards associated with its design and construction as listed in the
Technical File.

Signed *John Fawk*
on behalf of TWOSE of TIVERTON LIMITED *Responsible Person*

..... *Chief Design Engineer* *June 2003*

Status

Date

EC DECLARATION OF CONFORMITY

Conforming to EEC Directive 89/392/EEC

We,

TWOSE OF TIVERTON LIMITED,
6 Chinon Court, Lower Moor Way,
Tiverton Business Park, Tiverton, Devon, EX16 6SS.

Declare under our sole responsibility that:

The product (type) ... Hydraulic Arm Mounted Flailhead

.....

Product Code .. TWHD

Serial No. & Date Type

Manufactured by the above company/*

.....
(insert business name and full address if not stated above)*

Complies with the required provisions of the Directive 89/392/EEC, and AMD 91/368/EEC,
AMD 93/44/EEC, AMD 93/63/EEC and conforms with European Norm. BS EN 292.

Part 1: 1991 – Safety of Machinery – Terminology, methodology.

Part 2: 1991 – Safety of Machinery – Technical Specifications.

and other national standards associated with its design and construction as listed in the
Technical File.

Signed *John Frank*

on behalf of TWOSE of TIVERTON LIMITED

Responsible Person

..... **Chief Design Engineer**

Status

..... **June 2003**

Date

**THIS MANUAL IS TO BE HANDED TO THE CUSTOMER BEFORE
THE MACHINE IS TO BE USED FOR THE FIRST TIME.**

**THIS MANUAL (OR A COPY OF) MUST BE USED AND READ BY
ALL OPERATORS OF THIS MACHINE.**

TWOSE OF TIVERTON LIMITED

6 CHINON COURT
LOWER MOOR WAY
TIVERTON BUSINESS PARK
TIVERTON
DEVON
EX16 6SS

Telephone: 01884 253691
Fax: 01884 255189

All dimensions and capacities mentioned in this book are approximate. In pursuance of the company's policy of constant development, the right is reserved to depart, without notice, from any detail illustrated or specified in this book, without incurring the obligation to provide such modifications on the machine previously delivered.

No responsibility will be accepted by Twose of Tiverton Limited for any injury, damage or loss arising from the improper use of or lack of maintenance of any machinery supplied by them or from any failure of the user to comply with all instructions published by Tractor or Loader Manufacturers, particularly with the regard to maximum load capacities, tyre pressures and stability, or with instructions and regulations pertaining to Tractor Cabs.

INDEX

	<i>Page No.</i>
OPERATOR SECTION	
INDEX	3
GENERAL	4
SPECIFICATIONS	4
AIRBORNE NOISE EMISSIONS	4
GENERAL INFORMATION	5
SAFETY NOTES AND WARNINGS	6
ABOUT THE MACHINE	6
HEALTH AND SAFETY POINTS	7
PARKING MACHINE	10
NOTES	12
VEHICLE/TRACTOR PREPARATION	12
GENERAL INSTRUCTIONS	13
INTRODUCTION	15
OPERATIONS	16
TRACTOR SELECTION FOR 315/395 FLAIL HEDGETRIMMERS	16
ATTACHING HEDGETRIMMER TO TRACTOR	16
REMOVING HEDGETRIMMER FROM TRACTOR	20
OPERATING THE HEDGETRIMMER	22
TRANSPORTATION	25
MAINTENANCE	26
GREASE POINTS	26
PTO SHAFT	26
HYDRAULIC OIL	26
GEARBOX FOR HYDRAULIC PUMP	26
HOSES	27
CABLE AND CONTROL HANDLES	27
FLAIL HEAD	27
LAYING UP	27
PARTS SECTION	
FLAIL HEAD PARTS	30
FLAIL HEAD PARTS - Continued	32
PARTS FOR BOOMS	34
PARTS FOR MAIN FRAME	36
PARTS FOR MAIN FRAME CONTINUED	38
PUMP AND GEARBOX	40
PARTS FOR CONTROLS	42
RAM VALVE AND HOSES	44
ROTOR DRIVE - VALVES AND HOSES	46
HOSE LIST	48

GENERAL

SPECIFICATIONS

Specification for 315 Machine

Overall Height (machine folded for transport)	1.96m
Overall Width (machine folded for transport, from tractor's centre-line)	0.74m
Overall Length of machine (less PTO shaft)	0.67m
Total weight of machine (inc. Oil)	0.29 T

Specification for 395 Machine

Overall Height (machine folded for transport)	1.96m
Overall Width (machine folded for transport, from tractor's centre-line)	0.74m
Overall Length of machine (less PTO shaft)	0.67m
Total weight of machine (inc. Oil)	0.31 T

Note - Dimensions are approximate and will vary from tractor to tractor.

AIRBORNE NOISE EMISSIONS

The equivalent continuous A-weighted sound pressure level at the workstation (tractor seat) does not exceed 74dB(A). This value was recorded cutting hedges using a Dawe 1405C Sound Meter (BS 3489) on a Massey Ferguson 3090 Tractor complete with M/F Safety Cab.

GENERAL INFORMATION

- NOTE:- The provision of this information is a requirement of the Health & Safety at Work Act 1974.
- NOTE:- This handbook has been written to help the operator and service engineer/mechanic to use and understand the machine fully, safely and efficiently. It is written bearing in mind the Health & Safety requirements and the CE requirements which came into force from January 1st 1995.
- NOTE:- The handbook/manual will be supplied in a waterproof plastic outer cover to prevent damage from rain, condensation etc. The cover of the handbook will include its own part number, which includes information as to the type of machine and issue date of the manual in question.
- NOTE:- A 'CE' self certification document is supplied in a separate plastic cover and attached to the machine.
- DANGER NOTE:- It is very important that the handbook/manual is read thoroughly throughout, and is completely understood before attempting to attach, use or maintain the machine in any way.
- NOTE:- Further copies of this handbook/manual can be obtained from:-

TWOSE OF TIVERTON LIMITED
BLUNDELLS ROAD
TIVERTON
DEVON
EX16 4JT

TEL: 01884 253691
FAX: 01884 255189

SAFETY NOTES AND WARNINGS

Throughout the handbook the following sub headings are used to draw attention to various points of importance.



DANGER
WARNING

This is used to draw attention to very important instructions which **MUST** be followed precisely to avoid injury or death.

CAUTION

This is used to draw attention to instructions which **MUST** be followed to avoid damage to operator, machine, process or the environment.

NOTE:-

This is used to highlight points used for supplementary information.

ABOUT THE MACHINE

This machine is a Hedgetrimmer of the type known throughout the agricultural industry as a "Flail Hedgetrimmer".

The machine is intended to be attached to an agricultural vehicle by means of the three-point-Linkage couple-up system. The linkage is in turn locked into position (to prevent movement between tractor and Hedgetrimmer) by means two sets of adjustable tie bars - forming an 'A' frame to ensure a rigid attachment/lock system.

The purpose for its production and its sole intention is to cut/trim hedges, banks, verges etc.

AT NO TIME must this machine be used for anything other than, or to do any job other than that for which it has been designed (see above) - In particular:

NEVER USE JIB ARMS AS A CRANE

HEALTH AND SAFETY POINTS



DANGER
WARNING

Never attempt to assemble, couple up, or operate machinery until you understand fully the functions, controls and safety precautions required, as shown in the operators manual.



DANGER
WARNING

Always follow tractor safety operations and instructions VERY carefully. NEVER TAKE RISKS



DANGER
WARNING

NEVER LEAVE TRACTOR SEAT WHILST ENGINE - OR MACHINE IS RUNNING



DANGER
WARNING

NEVER USE HEDGETRIMMER BOOM ARMS AS A CRANE IN ANY FORM



DANGER
WARNING

It may be necessary to stabilise the whole unit once coupled up- by ballasting tractor's rear wheels and/or fitting counterbalance weights to the tractor.

Tractor rear wheel track setting could also be widened as a further method of increasing stability. (Check with agent).

CAUTION.

Be aware of warning stickers and instruction stickers on the machine as care must be taken and instructions obeyed.

CAUTION

Contact your dealer should you need advice, assistance, or if you do not understand any part of the manual or machine. NEVER ASSUME - if you are not sure - ASK.

CAUTION

Machine MUST NOT be altered or modified in any way without permission. No liability will be accepted in respect of a machine which has been modified without manufacturers permission.



DANGER
WARNING

Never attempt to Service/work on/adjust in any way any machinery that is in an unsupported or poorly supported state.

Most machines will need additional support in order that the worker's safety is not reliant only on hydraulic or other services of the machine or tractor.

For Example:-

Any three point linkage mounted machinery
Front Loaders
Digger Booms
Hedgetrimmer booms etc. etc.

Always ensure that machinery is safely supported and propped in position.



DANGER
WARNING

Always ensure that the wheels of any wheeled implement/machinery are 'chocked' firmly and that the implement will not move, before attempting to 'service' or 'work on' the implement/machine in any way or form.

CAUTION

Always SWITCH OFF tractor engine before attempting to carry out adjustment, service repairs or inspections on machinery.



DANGER
WARNING

Always be aware of your surroundings, and operate machinery accordingly. Beware of confined or tight areas and restricted height due to buildings, overhangs etc. Drive and operate machines with weather conditions in mind; such as sun, rain, ice, snow, wind etc. **Make allowances in all situations.**

CAUTION

Never operate machine in a reckless or uncaring manner. Respect other road users and be patient.

Highway Use

When operating machinery on the Highways the operator should consult the Local Highways Department regarding notification and approval, as rules and regulations will vary from local authority area to area. The Highways Department regulations must be followed.

NOTE:- In general it is expected that the Tractor/implement will follow (go with) the flow of traffic - but this should be confirmed by consulting the local Highway Authority rules.

Always use 'STOP'-'GO' boards or whatever system the Local Highways Department advise, and ensure these are positioned correctly in relation to machine's operating area.

Have respect for passing traffic and keep passing any lane free from obstruction.

Allow time for walkers and cyclists to clear the site. Consult the Lighting Regulations for correct procedures when using or travelling on the highway.

CAUTION

Never carry passengers on machinery or on tractors.
Ensure bystanders/onlookers are kept well away from operational area of the machine.

NOTE:-

NEVER ALLOW ONLOOKERS/BYSTANDERS TO STAND IN FRONT OF CUTTER HEAD OR IN LINE WITH FLYING DEBRIS.

A sideways and rearward NO-GO area should be kept:

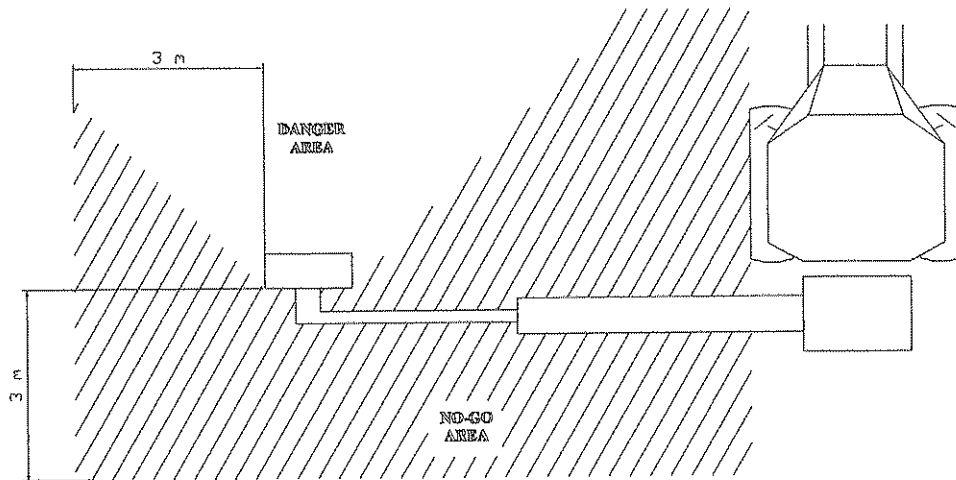

CAUTION

Never operate cutting rotor with blades looking towards operator or towards others. Cutters must always be operated towards hedge or bank/verge etc.

CAUTION

Never walk underneath the machine for any reason, especially if unit is still operating.

PARKING MACHINE

When machine is being removed from tractor linkage and being parked up it is essential that a good firm base and level site be found.

Always chock and prop machine to ensure a good firm position to leave parked. Ensure that stand legs of machine are correctly locked into position.

CAUTION

Never allow children to play on, or around, parked machinery.

CAUTION

Never wear loose fitting or ragged clothing which could get caught in machinery or controls.



DANGER
WARNING

Always ensure safety screens are fitted into position to protect operator from flying debris.

CAUTION

Ensure visibility is clear through cab-screens at all times.

CAUTION

Ensure workstation controls, Joysticks, Cable levers etc. are positioned correctly to suit operator, and not obstructing other driving functions.

Controls must NOT obstruct entry and exit to cab.

Worn-out and spent waste oil, grease and other noxious substances must always be disposed of in suitable and legally approved dumping containers suitable for the waste in question.

CAUTION

Always dispose of discarded or worn out parts thoughtfully - by disposing of them in an approved and specified legal scrap site, bin or skip.

CAUTION

If the head is not closed-up during transportation from job to job and especially between bouts, whip can be caused in the booms due to uneven surfaces etc. Such whip will stress the machine much more than typical work.

For transportation ensure that the whole machine is folded in fully and the transport strut employed.

Safety of control levers/joystick controllers

The control levers which operate the hydraulic boom cylinders on the machine will automatically centralise themselves in the CENTRE-OFF when the control lever is released. This reduces the chance of unwanted movement or overrun of booms.

VEHICLE / TRACTOR PREPARATION

We recommend vehicles are fitted with cabs using 'safety glass' windows and protective guarding when used with our machines.

Fit Operator Guard (*part no. 73 13 324*) using the hooks provided. Shape the mesh to cover all vulnerable areas.

Remember the driver must be looking through mesh and/or polycarbonate glazing

when viewing the flail head in any working position - unless the vehicle/ cab manufacturer can demonstrate that the penetration resistance is equivalent to, or higher than, that provided by mesh/polycarbonate glazing. If the tractor has a roll bar only, a frame must be made to carry both mesh and polycarbonate glazing. The operator should also use personal protective equipment to reduce the risk of serious injury such as; eye protection (*mesh visor to EN1731 or safety glasses to EN166*), hearing protection to EN352, safety helmet to EN297, gloves, filter mask and high visibility clothing.

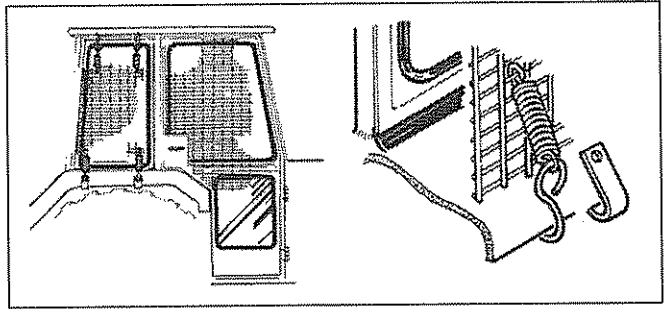

Vehicle Ballast: It is imperative when attaching 'third-party' equipment to a vehicle that the maximum possible stability of the machine and vehicle combination is achieved – this can be accomplished by the utilisation of 'ballast' in order to counter-balance the additional equipment added.

Front weights may be required for rear mounted machines to place 15% of total outfit weight on the front axle for stable transport on the road and to reduce 'crabbing' due to the drag of the cutting unit when working on the ground.

Rear weights may be required to maintain a reasonable amount of rear axle load on the opposite wheel from the arms when in work; for normal off-ground work i.e. hedge cutting this should be 20% of rear axle weight or more for adequate control, and for ground work i.e. verge mowing with experienced operators, this can be reduced to 10%.

All factors must be addressed in order to match the type and nature of the equipment added to the circumstances under which it will be used – in the instance of Power Arm Hedgecutters it must be remembered that the machines centre of gravity during work will be constantly moving and will differ from that during transport mode, therefore balance becomes critical.

Factors that effect stability:

- Centre of gravity of the tractor/machine combination.
- Geometric conditions, e.g. position of the cutting head and ballast.
- Weight, track width and wheelbase of the tractor.
- Acceleration, braking, turning and the relative position of the cutting head during these operations.
- Ground conditions, e.g. slope, grip, load capability of the soil/surface.
- Rigidity of implement mounting.

Suggestions to increase stability:

- Increasing rear wheel track; a vehicle with a wider wheel track is more stable.
- Ballasting the wheel; it is preferable to use external weights but liquid can be added to around 75% of the tyre volume – water with anti-freeze or the heavier Calcium Chloride alternative can be used.
- Addition of weights – care should be taken in selecting the location of the weights to ensure they are added to a position that offers the greatest advantage.
- Front axle locking, check with tractor manufacturer.

The advice above is offered as a guide for stability only and is not a guide to vehicle strength. It is therefore recommended that you consult your vehicle manufacturer or local dealer to obtain specific advise on this subject, additionally advice should be sought from a tyre specialist with regard to tyre pressures and ratings suitable for the type and nature of the machine you intend to fit.

GENERAL INSTRUCTIONS

1. Before attaching any machine to a tractor or loader make sure that implement is still standing firmly on a good solid level site. (This will depend of course on how well the site was chosen previously).
Check that any wheels are chocked correctly and that supports/props are in position where necessary to prevent booms etc. from dropping.
2. Before and during the manoeuvring of the tractor or vehicle in order to attach machinery/implements, make sure that NO other persons are in the vicinity. Keep other persons well clear and make known your intentions, all the while keeping a sharp lookout whilst reversing and aligning machines for coupling up.
3. Always ensure that brakes are applied correctly to secure the tractor into the selected position. This will prevent the vehicle from moving off on its own to cause injury and damage.
4. Make sure that the lift arms and top link ball ends of the tractor are properly fitted to the machine/implement by using the correct adaptor sleeves where necessary. Retaining pins of the correct type must be used on all three point linkage points. Secure pins with relevant pin and ring assembly.
5. If the machine is of the drawbar type - check that the hitch on the tractor is in good condition and that the hitch pin used is of the correct size and type, and is properly secured when fitted.
6. Should it become necessary to make any adjustments or service the machine while raised on the tractor linkage, or raised on a front end loader, trestles or suitable supports **MUST** be positioned to support machine to prevent accidental dropping of lift arms, loader arms or mechanical failure.

MACHINES MUST ALWAYS BE PROPPED AND CHOCKED

7. Never attempt to work on, adjust or service repair machinery of any kind whilst it is still running or working. Always stop the machine and **STOP THE TRACTOR ENGINE** before any service/repairs begin.

SWITCH OFF TRACTOR ENGINE BEFORE LEAVING TRACTOR SEAT

8. In transit always use transport stays or locking devices where provided.

If, as in the case of some longer machines, the unit is transported lengthwise, make sure that the front of the tractor is suitably ballasted to maintain stability.

A method of achieving this to add suitable weights to a correctly specified and fitted front weight frame.

9. Always use machines in a sensible and reasonable manner and do not attempt to use them for work which they are not intended. Avoid overloading and abusing them as this can cause damage to machine and tractor and can be very dangerous.

10. When unhitching/detaching a machine from a three point linkage or from a front end loader ensure that any stands or legs are securely positioned. The machine must be parked where it will not be a safety hazard or cause annoyance to others. Make sure that chosen parking site is firm and level.

11. Carry out regular periodic maintenance, always with safety in mind.

12. Ensure regular maintenance procedures are maintained for the lifetime of the machine.

13. **HEALTH AND SAFETY RULES AND REGULATIONS MUST BE ADHERED TO IN ALL AGRICULTURAL RESPECTS.**

INTRODUCTION

1. The construction is of welded steel fabricated assemblies. The 315 machine has a horizontal reach of 3.2m and the 395 of 4m. The cutting heads are of a robust construction; with a cutting width of 0.85m on the 315 and 1m on the 395.
2. The machine is fitted with back-to-back flail blades mounted on shackles. These are intended for cutting grass and light growth in 'UP' and if necessary 'DOWN' cutting directions. No other flail options are offered: this is because the machine is intended for lighter work.
3. The drive is direct from the hydraulic motor to the rotor.
4. A swinging link 'break back' system is built into all models. This protects components by allowing the head to swing backwards and upwards through a short distance when encountering obstructions.
5. Two parking stand legs are fitted to the machine. At the head side of the machine one can be moved from work to parking by removing the retaining clip and replacing the stand back into its socket from above. The other, at the tank end, can be moved from work to parking by removing pins and park at rear of machine. The machine is most stable when the head and booms are closed into the transport position.
6. The use of a single-acting main lift ram prevents any chance of the head unit being powered into the ground; which would cause undue stresses. This protects the whole machine and is most useful when cutting verges, banks, etc. An optional accumulator float kit allows most of the weight of the head to be carried by the booms even when cutting undulating terrain.
7. Hydraulic hoses on machines have been kept as unobtrusive as possible to minimise the risk of their snagging.
8. The control valve slice for angling the cutting head has a detent facility for head flotation which is of value when cutting verges, banks, etc.
9. The nose or front guard of the flail head incorporates a welded-in strip to reduce the risk of wire being dragged onto the rotor at high speed. This is not, however, as good a safeguard as ensuring that the machine doesn't come into contact with wire in the first place.

OPERATIONS

TRACTOR SELECTION FOR 315/395 FLAIL HEDGETRIMMERS

For the 315 tractor size must be a minimum of 26kW (35 HP)

For the 395 tractor size must be a minimum of 26kW (35 HP)

The tractor must be equipped with a power take off shaft which must run at no more than 540 rpm during operation.

The PTO shaft should run clockwise when looking at the rear of tractor and should be 1 3/8" SAE - 6 spline type, enabling the standard PTO shaft supplied to be fitted.

It may be necessary to fit counterbalance weights (on approved mountings) or to ballast the tractor's rear wheels. **It is vital to ensure that the unit is stable.**
A wider track setting can be advantageous in curing stability problems: contact your agent for advice.

Four wheel drive tractors, with their extra weight, larger front wheels and better grip tend to be more stable when operating these machines.

ATTACHING HEDGETRIMMER TO TRACTOR

IMPORTANT:- Ensure machine is parked on a firm and level site without any bystanders or onlookers.

READ AND UNDERSTAND the General and Health and Safety instructions given in this manual.

1. FOR PIN TYPE LOWER LINKAGE EYES ONLY

Remove spring pins, lift pins and spacers supplied with Hedgetrimmer from lower link positions of linkage frame.

Slowly and very carefully reverse the tractor towards the machine linkage frame.

With care, ensure that tractor lower link ball eyes fit between the lower jaws of the linkage frame and that the pin holes are aligned.

SWITCH OFF TRACTOR ENGINE AND ENSURE HANDBRAKE IS ON

With holes of tractor lower link eyes in line with lower jaw holes of frame, the lower linkage pins should now be refitted.

Secure lift pin into position using the 7/16" diameter pin and ring assembly.

1(b). FOR AUTOMATIC QUICK CROOK-ON ONLY LOWER LINK

Remove spring pins and lift pins supplied with Hedgetrimmer from lower link positions of linkage frame. Then push lift pin through the tractor's lower link ball end between ears of frame. Then secure into position using 7/16" diameter pin and ring also supplied.

Next slowly and very carefully reverse the tractor towards the machine's linkage frame.

Carefully ensure that tractor lower links fit between the lower jaws of the linkage frame and are aligned with the relevant ball eyes (now already on lower lift pins).

Raise tractor lower link arms to a position that allows the ball to engage correctly into the housing in the lift arm.

2. The staybars are designed to allow for Category 1 or Category 2 linkages. The holes in one of each pair of bars will be found to be 3/4" Diameter, 20mm (Cat 1) and in the other 1", 25mm (Cat 2).

The shouldered spacer which fixes the lower ends of the bars to the main frame can be placed so that it suits whichever hole size remains.

For 'continental' hitches, placing the 1", 25mm holes to the top will allow the staybars to be affixed to the 'continental' ladder hitch frame rather than the top link position.

With the bases of the staybars detached from the main frame of the machine their tops can be secured along with the top link to the tractor's top link position (or ladder frame of 'continental' hitch).

3. Start up tractor. Raise the whole machine on the linkage until a height is reached which is a compromise between a horizontal path for the PTO shaft and 300mm (12") of ground clearance for the main frame.

With the machine at this height, remove the two M12 bolts on each side to move the lower staybar of each pair in relation to the upper to get its bottom hole closest to alignment with the intended position in the main frame. The two M12 bolts for each pair can then be replaced (ensuring the two sides match) and the height of the linkage adjusted to allow the bolt and spacer to secure the lower ends of the staybars to the main frame. Tighten all relevant nuts/bolts.

Lower the three point linkage to allow weight of machine to be taken on stabilisers.

Tractor lower linkage check chains assemblies should now be tightened to ensure that tractor arms are locked sideways and machine is positioned centrally at rear of tractor.

Loose check chains are the primary cause of machines rocking on the back of the tractor.

Top link should now be adjusted to ensure Hedgetrimmer is level from front to rear.

4. Check the length of the PTO shaft.

When connected from tractor to machine the shaft should engage by $1/3^{\text{rd}}$ of the total shaft length: that is the male part should be halfway from disengaged to fully bottomed out.

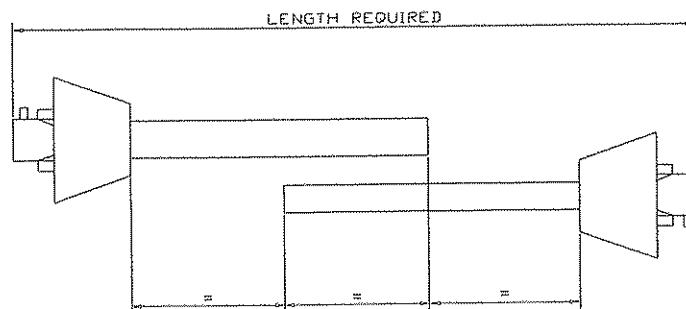

Do not use the machine until shafts have been cut to the correct length.

5. Fit the PTO shaft.

Ensure the shaft is correctly fitted to matching splines at both ends.

Fit the anti-spin chains of the PTO guard to a rigid non turning assembly.

6. Two parking stand legs are fitted to the machine. Remove the retaining clip from the head end stand leg, invert it and replace it in the socket, replacing the clip. Remove one pin and clip from the tank end stand leg, swing up into the work position and replace pin and clip.

7. The mesh safety screens should now be fitted.



**DANGER
WARNING**

All glass screens on the relevant side of the cab must be protected.

The screens are designed to be fitted to the tractor cab on the cutting head side (i.e. for left-hand cut machines to left hand side of cab). Bolts, nuts and washers are supplied for fixing purposes.

8. Fix valve control handles into position:-

Control levers are supplied bolted together as a unit. Cables should not be forced into arcs of less than 150mm (6") in radius otherwise the controls will be stiff to operate and the cables will be damaged. The unit includes a support leg, which will slot into a bracket supplied for fitting to the tractor.

There are 3 controllers in the set. The locating bracket should be positioned on the inner wing face of the tractor cab in a suitable position for easy operation. It is suggested that the bracket is fitted to the left-hand wing for left-hand cut machines and right-hand wing for right-hand cut machines.

Bolts, nuts and washers are supplied for fixing. Certain cabs should not have any holes drilled in their sides: if in doubt check with your tractor dealer, who will be able to advise how to proceed if this is the case.

Once the bracket is fitted the controller unit can be lowered into the slot in the bracket and secured by tightening the securing screw (clockwise).

9. **IMPORTANT** - Check the oil level within the tank: it should be at or near the green dipstick band (on the filler/breather unit cap) and well above the red band.

10. The tractor's power take off can now be engaged **CAREFULLY**.

Check that PTO is running correctly and that the guard is not spinning. Oil will now be pumping within the hydraulic system.

11. Check the movement of the hydraulic valves by operating the control handles. This should be done with great care until the operator gets a good 'feel' for the controls and feels competent. Each control lever is individually labelled as to which operation it controls.

The controller units are assembled in the following formation:

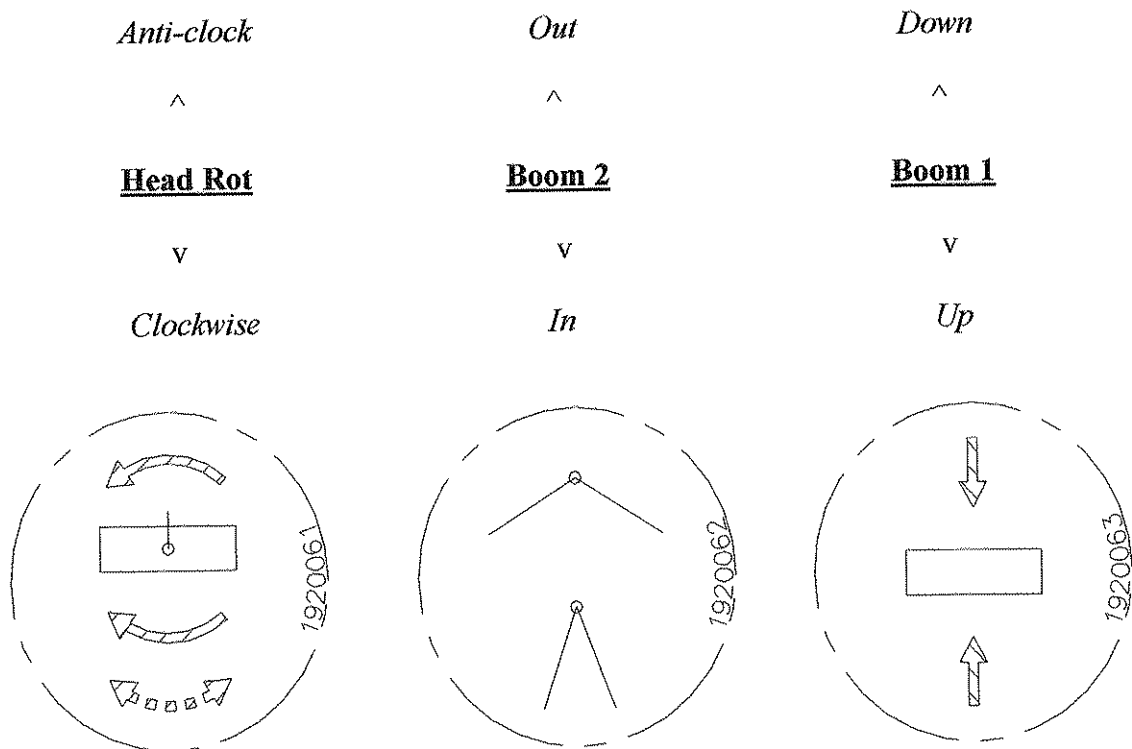

The formation could be changed to suit the individual, if so desired. Note that the order in which the valve slices are grouped on the block differs from this.

REMOVING HEDGETRIMMER FROM TRACTOR

1. Select a good clear, level and firm site on which to detach and store machine.
2. **IMPORTANT**
Using the hydraulics, fully close the head angling ram. Then fully close the first and second rams and fit the transport strut; bringing the machine to a stable closed position.
3. Disengage the PTO drive and **STOP THE TRACTOR ENGINE.**
4. Move the stands from their work positions to their parked positions, securing them with the pins and R clips provided.

5. Unbolt the stabiliser bars at their bases. Carefully taking the weight of the machine on the linkage will ease the tasks of loosening and removing the bolts.
Using tractor 3 point linkage lower the Hedgetrimmer so that stands are on the floor.
The top link may have to be adjusted to ensure that the trimmer is upright and safe.
Make sure that the trimmer is properly settled and safe on the stands.
Disconnect top link assembly from tractor.

6. Remove control handle set from tractor and stow on trimmer. Note, for semi-independent machines, 2 hoses (supply and return) must be uncoupled from tractor auxiliary ports and stowed on the machine.

7. Disconnect PTO shaft and anti-spin chains (tractor end).

8. For pin type lower link arms, remove lower lift pins from linkage.
For quick hitch crook-on arms, release crook locking levers and lower arms away.

Tractor linkage arms are now free of Trimmer.

9. Draw tractor slowly away. Many operators stop about 300mm (12") away to double-check that tractor and machine have completely parted company and that no connections or couplings have been forgotten for any reason.

Safety screens can now be removed if so desired.

10. Replace lower linkage pins back into relevant positions on mounting frame and secure with link pins.

11. Make sure tractor top link pin is replaced and secured with its linch pin.

OPERATING THE HEDGETRIMMER

The vehicle driver should be conversant with all tractor controls and capabilities.

It is always advisable for the tractor driver to practice the controls and operations of the Hedgetrimmer **before** commencing work.

The speed of cutting when Trimming will depend on the size, quantity, and type of growth to be cut. A speed slow enough to suit the conditions should be selected, ensuring that engine speed gives a PTO speed of 450 rpm for general use.

This 450 rpm is recommended for best trimming results and performance.

Variation from this recommended rpm should be kept to a minimum and never at any time should PTO rpm exceed 540 rpm.



DANGER
WARNING

Cutting head should be kept as close to tractor as conditions and cutting position permit. This ensures the maximum stability of the unit.



DANGER
WARNING

Never operate rotor with cutter flails directly towards operator, i.e., underside of head towards operator.

CUTTING THICKNESS LIMIT

SOFTWOOD

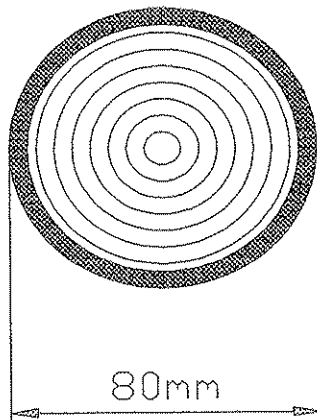

HARDWOOD

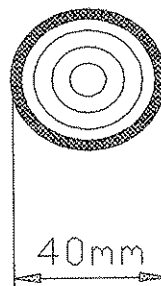

ROTOR ROTATION DIRECTION

On fully-independent machines (only) a choice of rotation direction is offered.

The 'upward' cut is recommended for trimming grass and one to two years growth of hedge.

DOWNWARD CUTTING IS NOT RECOMMENDED - and should only be considered for really heavy cutting of large diameter growth. Even then, it is important that down cutting be limited to a minimum and only for very short periods. There is a risk of serious damage to the hydraulic system should the rotor direction be reversed without it first coming to rest.



DANGER
WARNING

At NO TIME should the rotor be cutting upwards at front with front cowling removed.



DANGER
WARNING

With rotor cutting downwards at the front the roller must not be removed.

On leaving the factory the machine will be set for upward rotor cutting.

NEVER CHANGE DIRECTION OF CUT WHILST ROTOR IS STILL TURNING.

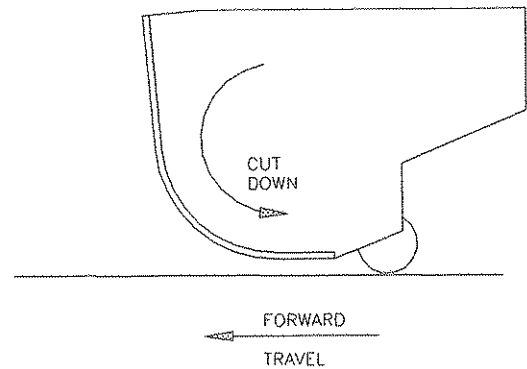
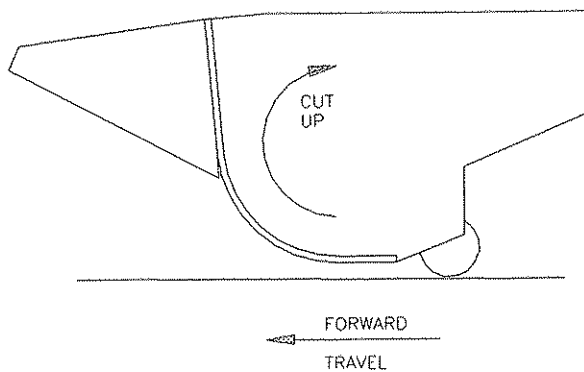

The motor spool control lever, sited on the motor spool valve, has a 'balk lock' device fitted to it to ensure that the rotor's cut direction cannot be accidentally reversed. The control allows the lever to be moved in one direction only, from centre OFF position to selected rotor cut direction.

ADJUSTING ROLLER HEIGHT

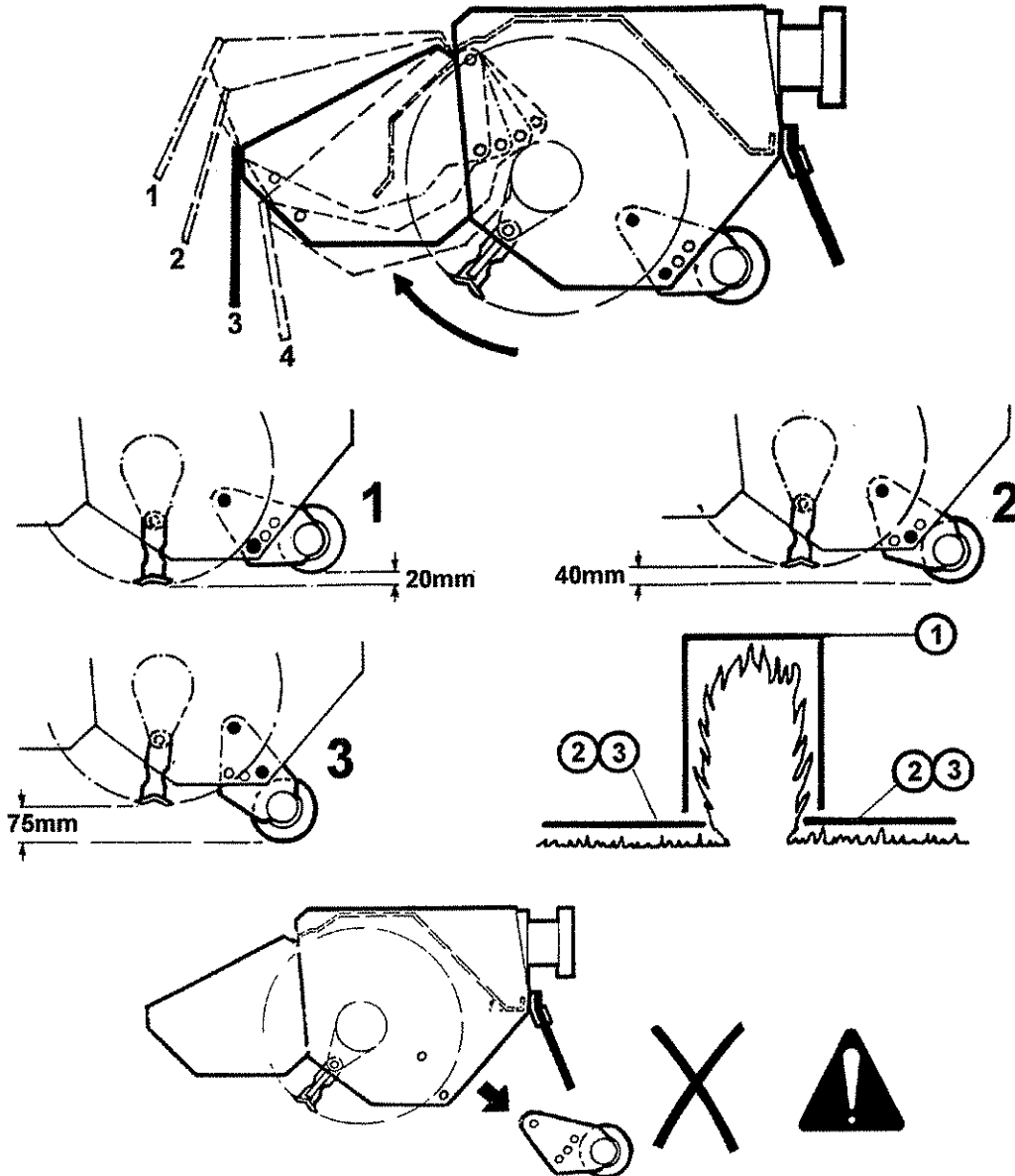

HYDRAULIC CONTROLS - CUTTING POSITION

The cutting head must at all times be lowered gently into its cut position. Never drop the head into work at speed.

When cutting at ground level (grass etc.), the head must be lowered gently to give a slight contact pressure of roller to ground.

IMPORTANT: Ensure rotor and roller do not get involved in high obstacle forces such as rocks, stones, stumps etc. Keep rotor away and free from wire, as to entangle wire into rotor is very dangerous and very costly.

Should large obstacles be encountered or wire be caught in the rotor you must STOP IMMEDIATELY - Reset or clear before starting.

Normal obstacles and level variations should be overcome by operator by slowing the forward speed and raising or lowering the head to suit.

CUTTING HEAD

The rotor of the cutting head has been balanced prior to fitting: this is to ensure a vibration free cutting unit.

Should the rotor become blocked, hit an obstacle, loose a blade or blades, the rotor may be put into a state of imbalance. This will result in vibration in the rotor that will also be transmitted to other parts of the machine.

Should vibration occur **STOP IMMEDIATELY**, as to continue working could have serious consequences, not least damaging bearings and weakening the structure.

Once stopped clean rotor and check for loss of blades and bolts, replacing as required.

In severe cases, perhaps as a result of hitting solid objects with serious force, rotors can become bent, which will also cause vibrations. In such cases the rotor will have to be re-balanced, repaired or even replaced.

BREAKAWAY

When the head meets an obstruction a swinging link, to which the head side lower tractor link is attached, allows the head to swing backwards and upwards. This gives the operator time to stop the forward motion of the machine before damage can take place. Once the obstacle is cleared the weight of the machine causes the link to swing back, resetting the position of the cutting head.

Note - the machine can be damaged if it is worked with the link in a 'broken away' position.

TRANSPORTATION

- (1) Disengage rotor drive.
- (2) In a suitable sequence close all the rams. This will leave the head closed against the second boom, the second boom against the first and the first boom vertical.
- (3) Fit the transport strut. This will ensure that the booms/head cannot drift out into traffic or other obstacle.
- (4) Disengage PTO.
- (5) The unit is now ready for transport.

MAINTENANCE

GREASE POINTS

On the rotor end bearing and on some pivots of booms, links or rams a grease nipple will be found. Where it is not obvious its position will be highlighted by a transfer symbolising a grease gun. These should be greased daily.

PTO SHAFT

The PTO shaft should be examined weekly, both in regard to its mechanical condition and that of its plastic guarding. Any damage to the guarding should be rectified with urgency and the anti-spin chains **must** be used. Universal joints should be greased sparingly at this time. Fortnightly the internal shaft should be greased along its length to ensure that it will continue to allow the unit to telescope.

HYDRAULIC OIL

The hydraulic system will have been run-up and checked at factory prior to the machine being despatched.

The hydraulic tank will be filled with EXCELUBE ULTRA 46 hydraulic oil when the machine is delivered. Oil tank capacity is 85 litres (19 Gallons).

It is advisable NEVER to mix hydraulic oils, but if another suppliers' oil is to be used, then one that is known to be compatible must be chosen (check with oil supplier).

A bypass will operate should the return filter become excessively clogged. Though this protects the operator and other personnel it does mean that filtration then ceases. It is important therefore that:

THE OIL FILTER MUST BE CHANGED AT 50 HOURS INITIALLY AND EVERY 250 HOURS THEREAFTER

The oil level in the tank should be checked daily, using the dipstick integral with the filler/breather cap.

Contamination of the oil will necessitate it being changed: this is indicated by a darkening in its colour and/or it smelling 'burnt'.

Keeping the area around the filler cap clean (particularly when removing the cap), changing filters on time and using clean containers will all help to reduce oil contamination.

GEARBOX FOR HYDRAULIC PUMP

The gearbox powering the hydraulic pump(s) will be pre-filled to the correct volume of 0.5 litres, with an SAE EP90 gear oil. This grade must be used when topping up. Levels should be checked every few months using the sight glass on the gearbox and the oil should be replaced every 2 years.

HOSES

Hoses should be regularly checked to ensure that the metal braiding is undamaged.

Should damage have occurred, affected hoses should be replaced as their ability to withstand pressure will be reduced, increasing the risk of their bursting. Care should be exercised when replacing hoses to ensure that each new hose terminates at the same place as the hose it replaces and that its route is as the original.

Hose ends and other hydraulic connections should be checked daily to ensure there are no leaks.

CABLE AND CONTROL HANDLES

No maintenance of cables or controllers is necessary and cables should **not** be lubricated. Should the controls become difficult to operate the route of the cables should be checked to ensure that there are no kinks or excessively small radii.

FLAIL HEAD

Keep the cutting blades **VERY SHARP**; this should be inspected daily. Bolts and nuts holding flails to rotor should be checked frequently and kept **tight**. Missing or broken flails should be replaced immediately, as the imbalance will rapidly harm bearings and structure. When a single flail has to be renewed; if it has an opposing pair, this should be renewed also to maintain balance.

LAYING UP

Clean the machine and note any damage or repairs needed. Arrange for spares and repairs as required in preparation for next season.

The machine should be lubricated fully and any exposed bright surfaces greased **particularly** any exposed rods of rams.

Store machine in dry conditions, preferably undercover.

Twose 315 & 395
FLAIL TRIMMERS
Parts Manual

Edition No. 8176-11-11

FLAIL HEAD CASING ASSEMBLY

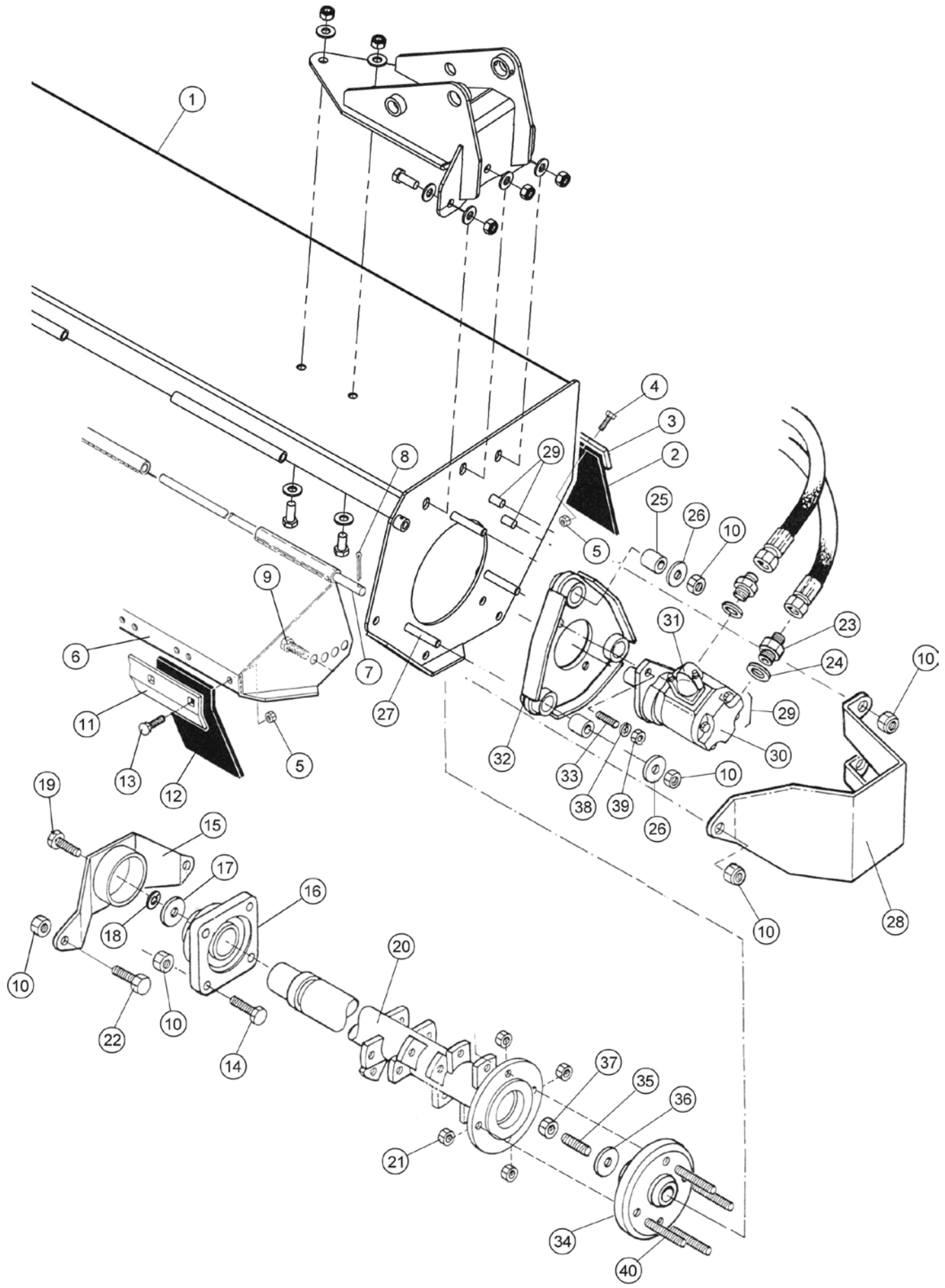

Ref.	Part Number	Description	Qty.	
			0.9m	1.0m
1	193.054	0.9 Metre Flailhead Casing - L/H Build	1	-
	193.055	0.9 Metre Flailhead Casing - R/H Build	1	-
	193.053	1.0 Metre Flailhead Casing - L/H Build	-	1
	193.051	1.0 Metre Flailhead Casing - R/H Build	-	1
2	41289.01	Rear Flap - 0.9m models	1	-
	41289.02	Rear Flap - 1.0m models	-	1
3	41290.01	Rear Clamp Strip - 0.9m models	1	-
	41290.02	Rear Clamp Strip - 1.0m models	-	1
4	9313034	Setscrew	8	9
5	9163004	Nyloc Nut	20	23
6	41283.01	Front Hood - 0.9m models	1	-
	41283.02	Front Hood - 1.0m models	-	1
7	41293.01	Hood Pivot Bar - 0.9m models	1	-
	41293.02	Hood Pivot bar - 1.0m models	-	1
8	9501325	Split Pin	1	1
9	9313046	Setscrew	2	2
10	9163006	Nyloc Nut	17	17
11	41291.01	Front Clamp Strip - 0.9m models	1	-
	41291.02	Front Clamp Strip - 1.0m models	-	1
12	41296.01	Front Flap - 0.9m models	6	-
	41296.02	front Flap - 1.0m models	-	7
13	9293054	Cup screw	12	14
14	9313086	setscrew	6	4
15	42496.01	Bearing Cover	1	1
16	03.008.01	Bearing Assembly	1	1
17	02.824.01	Special washer	1	1
18	9100206	Spring Washer	1	1
19	9313076	Setscrew	1	5
20	41284.03	Rotor - 0.9m	1	-
	41284.02	Rotor - 1.0m	-	1
21	05.968.02	Fine Nut	4	4
22	9313056	Setscrew	4	4
23	8581136	Adaptor	2	2
24	8650106	Bonded Seal	2	2
25	03.871.01	Rubber Bush	3	3
26	21259.01	Special washer	2	2
27	9213136	Bolt	3	3
28	41288.01	Motor Cover	1	1
29	193.067	Motor Assembly - consisting of:	1	1
30	T8131	Motor c/w Bearings	1	1
31	7939-E06	Elbow	2	2
32	09.132.01	Motor Mounting Plate	1	1
33	04.282.56	Stud	1	1
34	03.833.01	Motor Drive Plate	1	1
35	03.960.02	Stud	1	1
36	03.959.02	Washer	1	1
37	0141003	Clevelok Nut	1	1
38	9100205	Spring washer	2	2
39	9113005	Plain Nut	2	2
40	03.917.01	Stud	4	4

FLAIL HEAD CASING ASSEMBLY - Continued

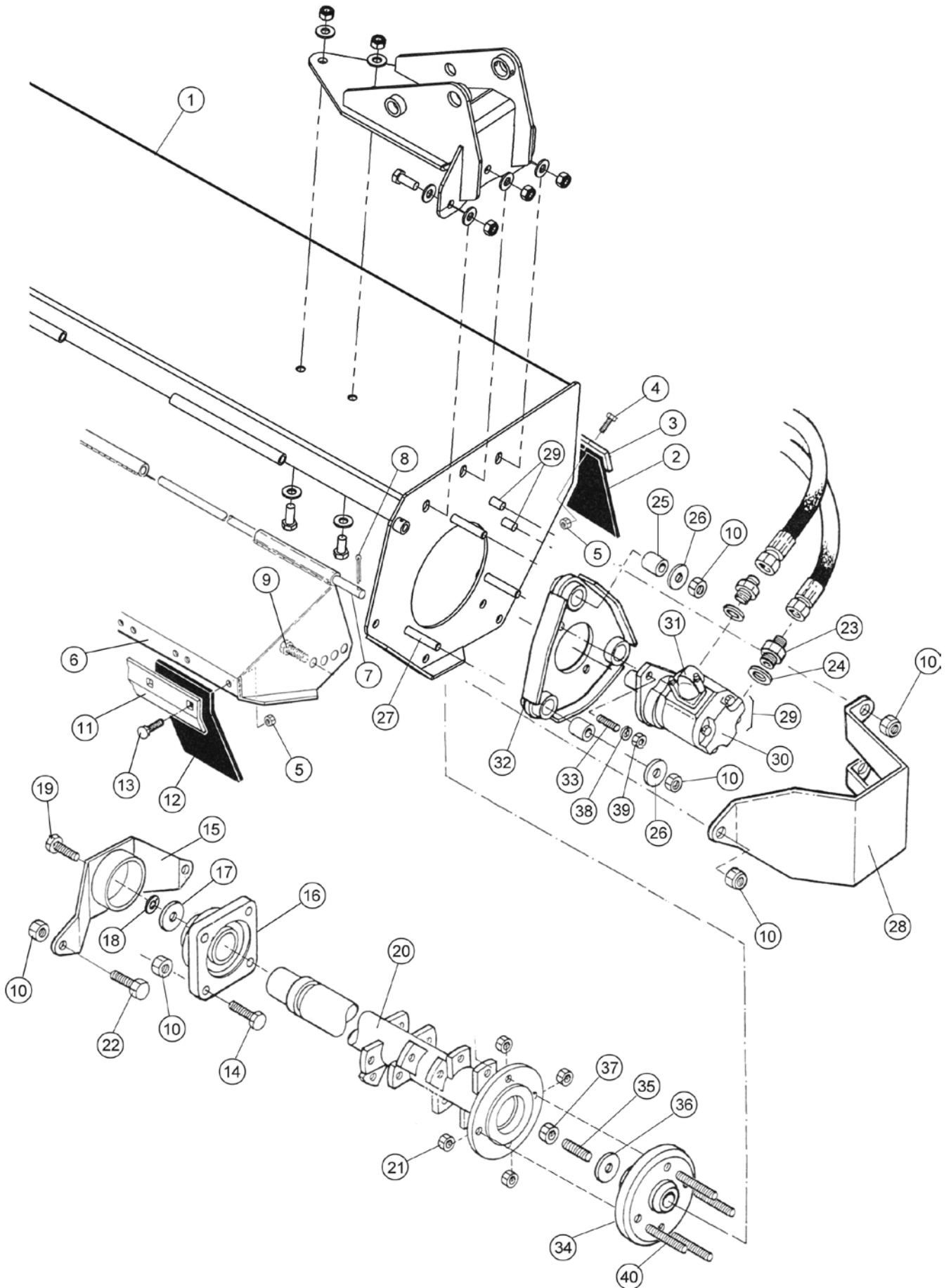

FLAILHEAD COMPONENTS NOT ILLUSTRATED

Ref.	Part No.	Description	Qty.	
41	45429.01	SERIAL NUMBER PLATE	1	1
42	7103230	1/8" POP RIVET	4	4
43	T410185	STICKER - 'TWOSE'	1	1
44	T1840280	STICKER - 'CUT DOWN'	1	1
45	T1850152	STICKER - 'WARNING DANGER AREA'	1	1
46	T1850151	STICKER - 'ENSURE BLADES ARE FREE'	1	1
47	T410184	STICKER - '//////////'	1	1
48	T410201	STICKER - 'GREASE POINT'	1	1

ROTORS & ROLLERS

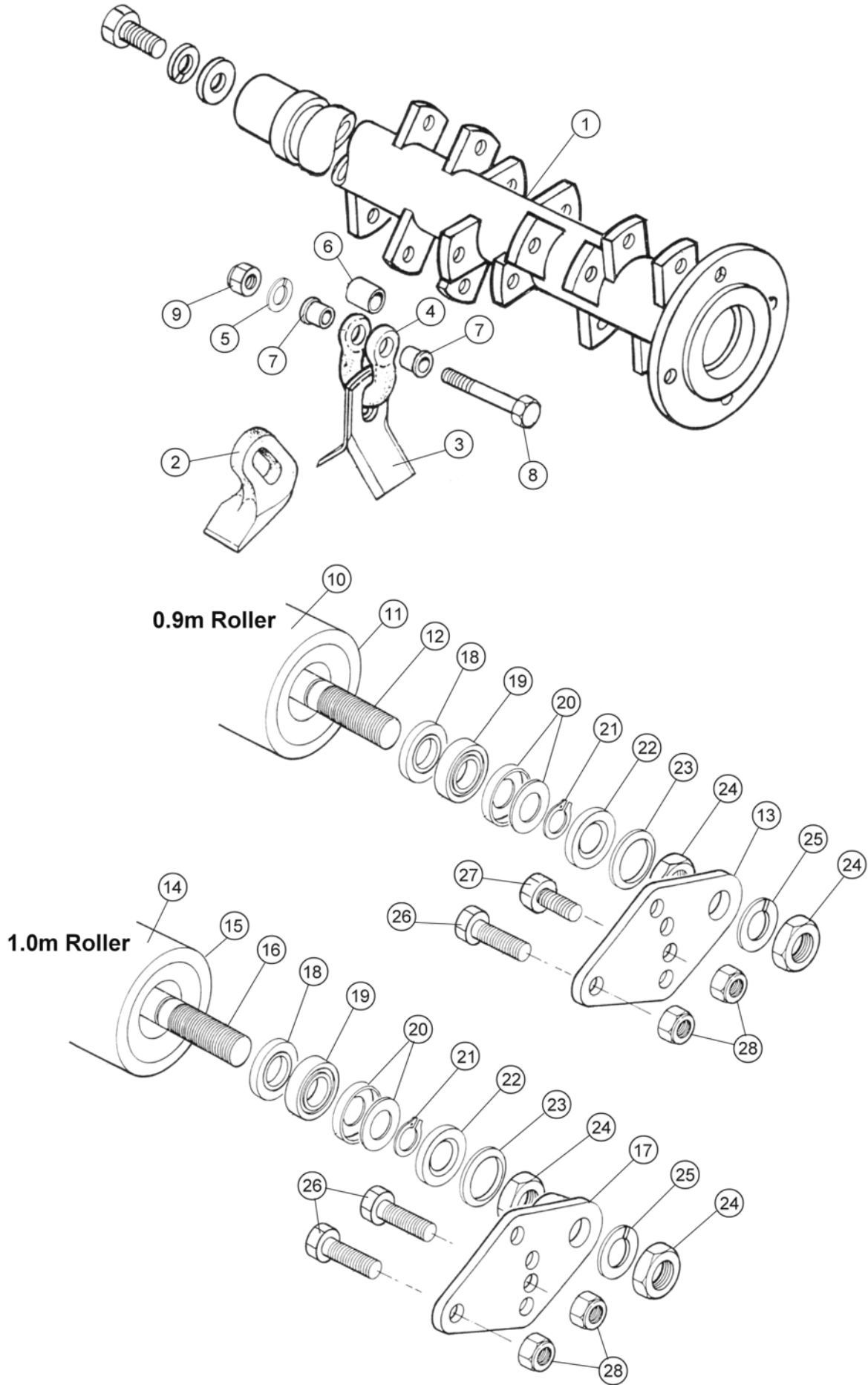

Ref.	Part Number	Description	Qty.	
			0.9m	1.0m
Rotors				
1	41284.01	Rotor - 0.9 Metre	1	-
	41284.02	Rotor - 1.0 Metre	-	1
2	7190463	Flail - Universal	24	28
3	7190166	Flail - Grass	48	56
4	05.895.01	Shackle	24	28
5	9100207	Spring Washer	-	28
6	02.807.01	Spacer	24	28
7	02.801.01	Collar - 0.9m Rotor only	48	-
8	05.775.10	Special Bolt - 1.0m Rotor only	-	28
	05.775.02	Special Bolt - 0.9m Rotor only	24	-
9	05.968.06	Self-Locking Nut - 1.0m Rotors only	-	28
	05.968.02	Self-Locking Nut - 0.9m Rotors only	24	-
Rollers				
10	41301.01	Roller Assembly - 0.9m	1	-
11	41301.31	Roller - 0.9m	1	-
12	41301.32	Roller Shaft - 0.9m	1	-
13	41285.01	Roller Bracket - 0.9m Heads only	2	-
14	41301.02	Roller Assembly - 1.0m	-	1
15	41301.33	Roller - 1.0m	-	1
16	41301.34	Roller Shaft - 1.0m	-	1
17	41285.03	Roller Bracket L/H - 1.0m Heads only	-	1
	41285.04	Roller Bracket R/H - 1.0m Heads only	-	1
18	04.456.07	Seal	2	2
19	04.456.11	Bearing	2	2
20	04.456.06	Labyrinth Seal	2	2
21	04.456.04	External Circlip	2	2
22	04.456.08	V Seal	2	2
23	04.456.05	Bearing Retainer	2	2
24	9113008	Plain Nut	4	4
25	9100208	Spring Washer	2	2
26	9313076	Setscrew	2	4
27	9313066	Setscrew - 0.9m only	2	-
28	9163006	Nyloc Nut	4	4

BOOM

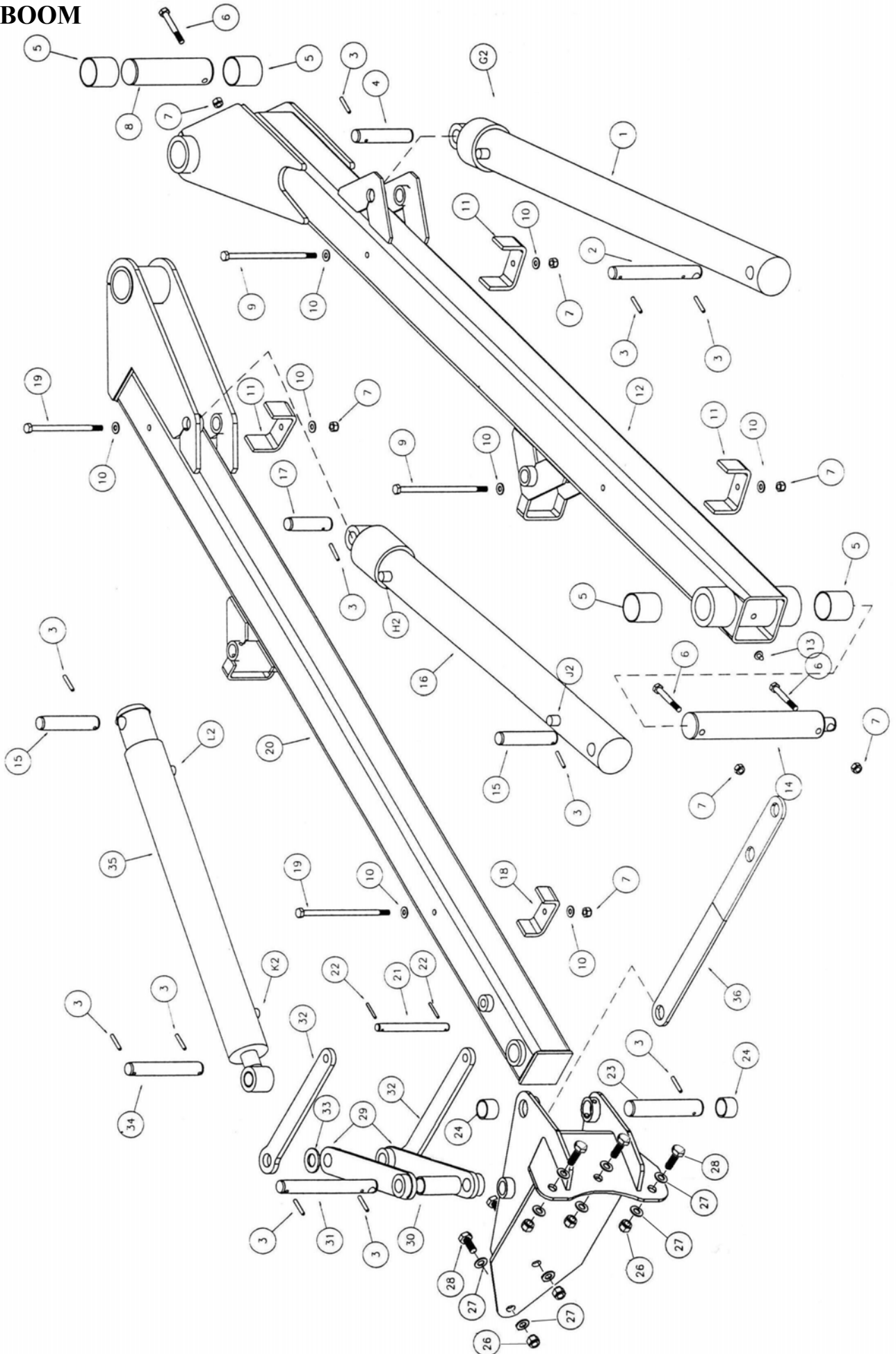

PARTS FOR BOOMS

<u>Ref.</u>	<u>Part Number</u>	<u>Description</u>	<u>Qty.</u>
1	1930001	Ram Primary	1.0
2	193.020	Pin 1st Ram Anchor	1.0
		20 Dia EN8 x 158 12/5xd	
3	8132	Spring Pin M 5 * 30	8.0
4	193.021B or 193.021A	Pin 1st Ram Rod	1.0
		20 Dia EN8 x 78 Sxd or 102 Sxd 5	
5	6257G	Bush 4040M Bronze/Steel	4.0
6	3262	Bolt M 8 * 60 (8.8)	3.0
7	3182	Stiffnut M8 Nyloc	8.0
8	193.022	Pin 2nd Boom Anchor	1.0
		40 Dia EN8 x 142 9xd	
9	8036	Bolt M 8 * 130 (8.8)	2.0
10	3111	Washer M8 Form A	10.0
11	193.042B	Pipe Clamp	3.0
12	193.008B or 193.008A	First Boom 4m or 3.2m	1.0
13	2923	G/Nipple M14 x 1.5	1.0
14	193.019	Pin Main Pivot	1.0
		40 Dia EN8 x 263 12/9xd	
15	193.023	Pin 2nd/HA Ram Anchor	2.0
		20 Dia EN8 x 103 5xd	
16	1930002	Ram Secondary	1.0
17	193.024	Pin 2nd ram rod	1.0
		20 Dia EN8 x 76 5xd	
18	193.042A	Pipe Clamp	1.0
19	8179	Bolt M8 * 150 (8.8)	2.0
20	193.009B or 193.009A	Second Boom 4m or 3.2m	1.0
21	193.028	Pin HA Pivot	1.0
		12 Dia EN8 x 130 4xd	
22	6351	Spring Pin M 4 * 30	2.0
23	193.025	Pin Head Pivot	1.0
		25 Dia EN8 x 128 5xd	
24	8039	Bush 2520M	2.0
25	193.052	Mounting Bracket Head	1.0
26	9163006	Stiffnut M12 Nyloc	5.0
27	9100106	Washer M12	10.0
28	9313066	Setscrew M12x30	5.0
29	193.011	Banana 2nd	2.0
30	193.030	Spacer 3/4 NB Med.x 65	1.0
31	193.029	Pin Head Angling	1.0
		20 Dia EN8 x 173 12/5xd	
32	193.010	Banana 1st	2.0
33	3062	Washer M20 Form A Bright	6.0
34	193.027	Pin HA Ram Rod	1.0
		20 Dia EN8 x 132 5xd	
35	1930003	Ram Head Angling	1.0
36	193-031-	Transport Strut	1.0

MAIN FRAME

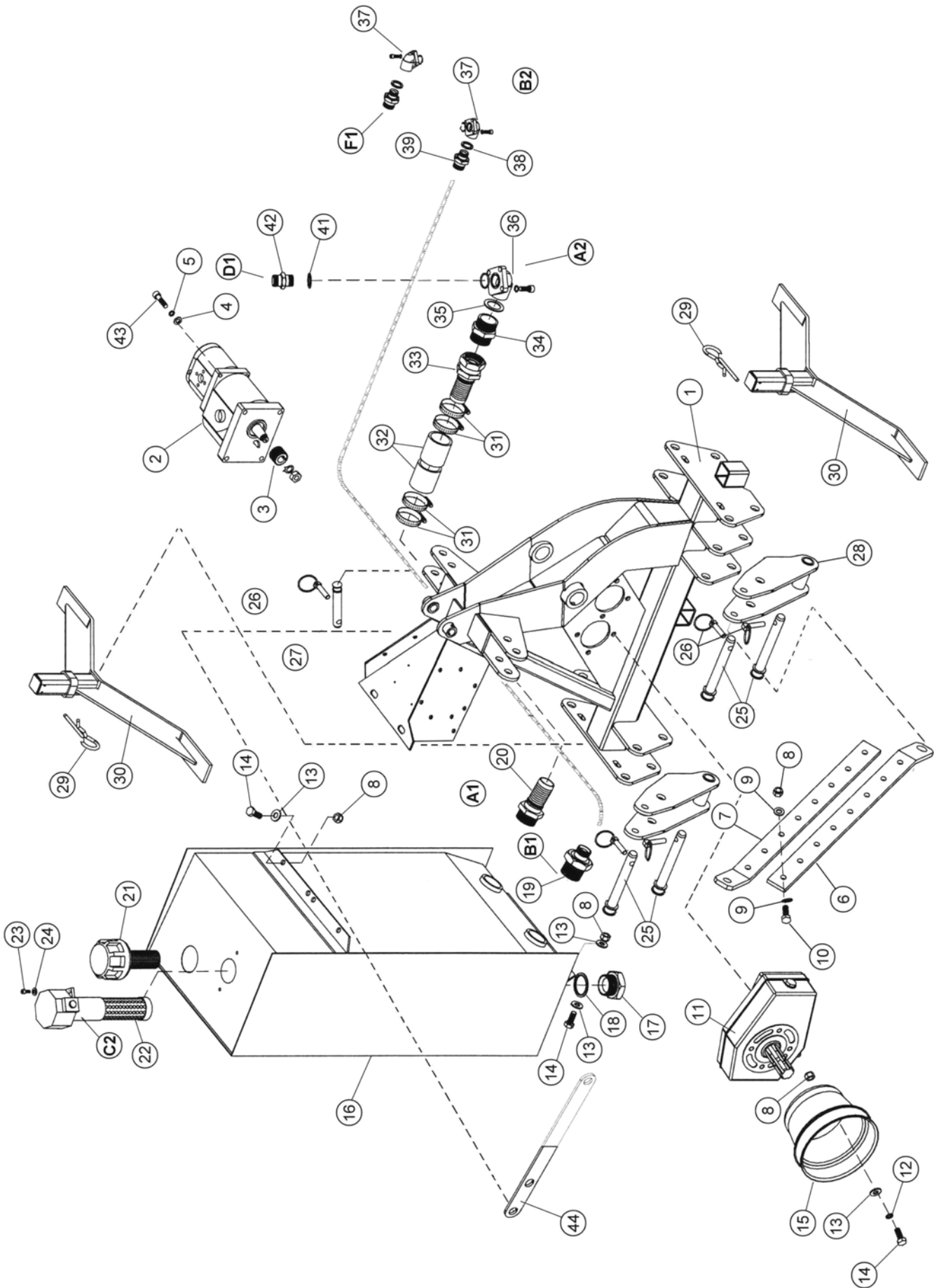

PARTS FOR MAIN FRAME

<u>Ref.</u>	<u>Part Number</u>	<u>Description</u>	<u>Qty.</u>
1	193.046	Main Frame	1.0
2	8201466	Pumps dual 9423E	1.0
3	7551	Coupling Taper GR3	1.0
4	3219	Washer M10 Form A Plated	4.0
5	2728	Washer M10 Spring	4.0
6	193.048	Stabiliser Bar	2.0
7	193.049	Stabiliser Bar	2.0
8	3082	Stiffnut M12 Nyloc	4.0
9	2716	Washer M12 Form A Bright	8.0
10	2962	Setscrew M12 * 35 (8.8)	4.0
11	8013573	Gearbox 1:3.4	1.0
12	2729	Washer M12 Spring	4.0
13	3192	Washer M12 Form C	14.0
14	2950	Setscrew M12 * 30 (8.8)	8.0
15	6385	PTO Guard	1.0
16	193.005	Tank	1.0
17	7894	Plug 1.1/2 bsp	1.0
18	3078	Seal 1.1/2" Dowty Bonded	1.0
19	8010	Adaptor 3/4 bsp x 1.1/2T	1.0
20	7999	Hose Tail 1. 1/2" BSP Male	1.0
21	6334	Filler/Breather	1.0
22	8133	Filter return	1.0
23	3494	Setscrew M 6 * 25 Cap Sock	2.0
24	2731	Washer M 6 Spring	2.0
25	8138	Pin Linkage 7/8" Long	4.0
26	0832	Pin Linch 7/16"	5.0
27	1657	Pin Linkage 3/4" (Bare).	1.0
28	193.045	Link Breakback	2.0
29	0806	R Clip mk4	4.0
30	193.007	Stand	2.0
31	7455	Clip Jubilee Diameter 40-55	4.0
32	8000	Hose Suction 38mm id	0.2
33	8087	Hose Tail 1.1/2" BSP Female	1.0
34	8088	Adaptor 1 B SP x 1.1/2cParallel	1.0
35	1934	Seal 1" Dowty Bonded	1.0
36	8135-E08	Elbow 1" 2PE8 IN c/w O Ring + 5/16" Whit Bolts	1.0
37	7939-E04	Elbow 1/2" 1PE4 c/w O Ring + 5/16" Screws	2.0
38	0909	Seal 1/2" Bonded	1.0
39	1834	Adaptor 1/2 bsp x 3/4	1.0
41	0934	Seal 3/4" Dowty Bonded	1.0
42	0935	Adaptor 3/4 bsp	1.0
43	5639	Setscrew M10 * 40 Cap Sock	4.0
44	193-031-	Transport Strut	1.0

PUMP & GEARBOX ASSEMBLY

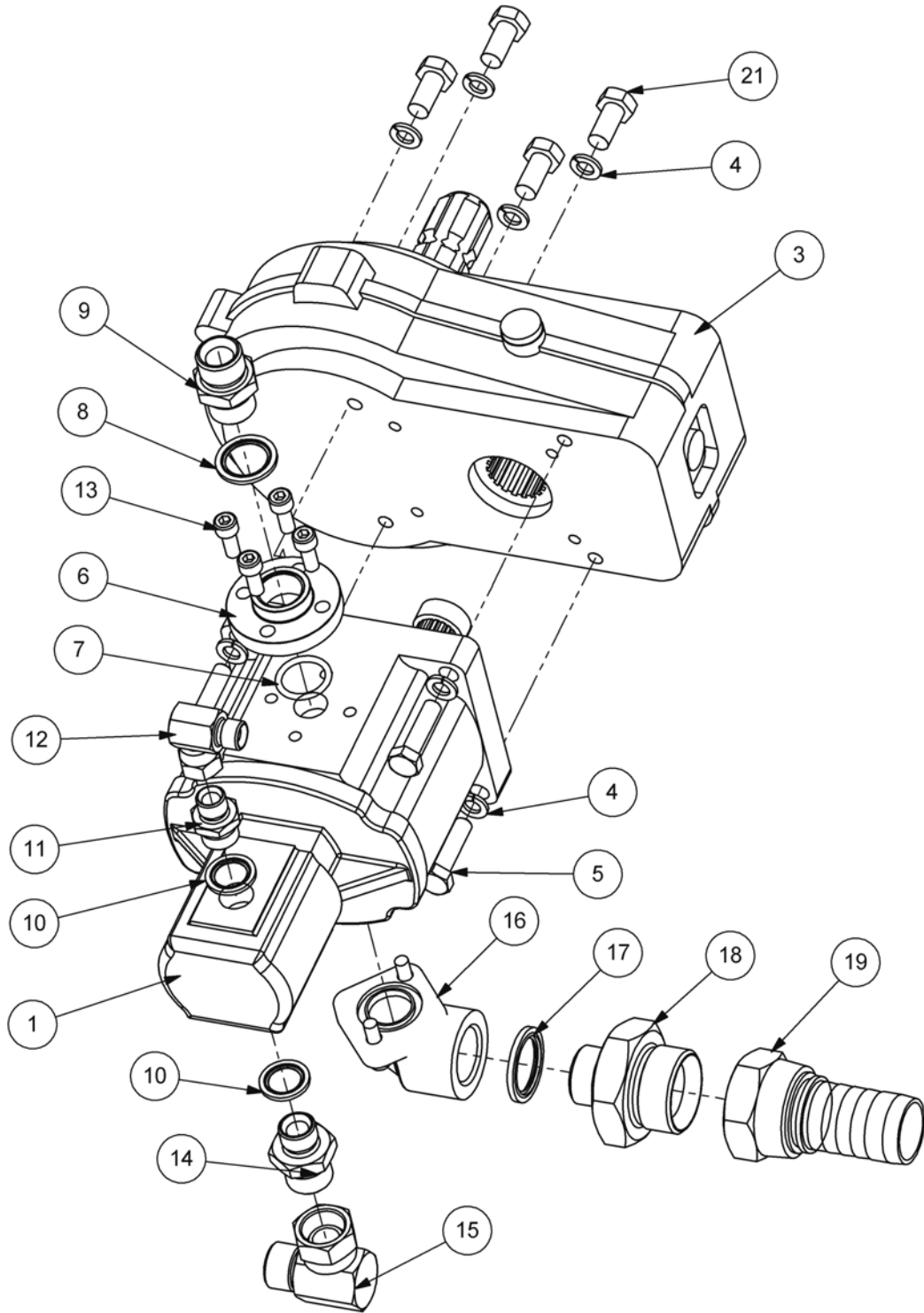

PUMP & GEARBOX ASSEMBLY

<u>Ref.</u>	<u>Part No.</u>	<u>Description</u>	<u>Qty.</u>
1	8201466	Tandum gear Pump	1
2	8013097	Coupling	1
3	8013573	Gearbox	1
4	9100205	Spring washer	8
5	9213085	Bolt	4
6	8013088	Pump Flange	1
7	8600119	O Ring	1
8	8650106	Bonded Seal	1
9	8581136	Adaptor	1
10	8650104	Bonded Seal	2
11	T0914	Adaptor	1
12	8581117	Adaptor Elbow	1
13	9343044	capscrew	4
14	8581130	Adaptor	1
15	05.835.03	Adaptor Elbow	1
16	8135-E08	Elbow c/w O Ring & Bolts	1
17	8650108	Bonded seal	1
18	T8088	Adaptor	1
19	T8087	Hose Tail	1
20	42415.03	Spacer	1
21	9313056	Setscrew	4

CONTROLS

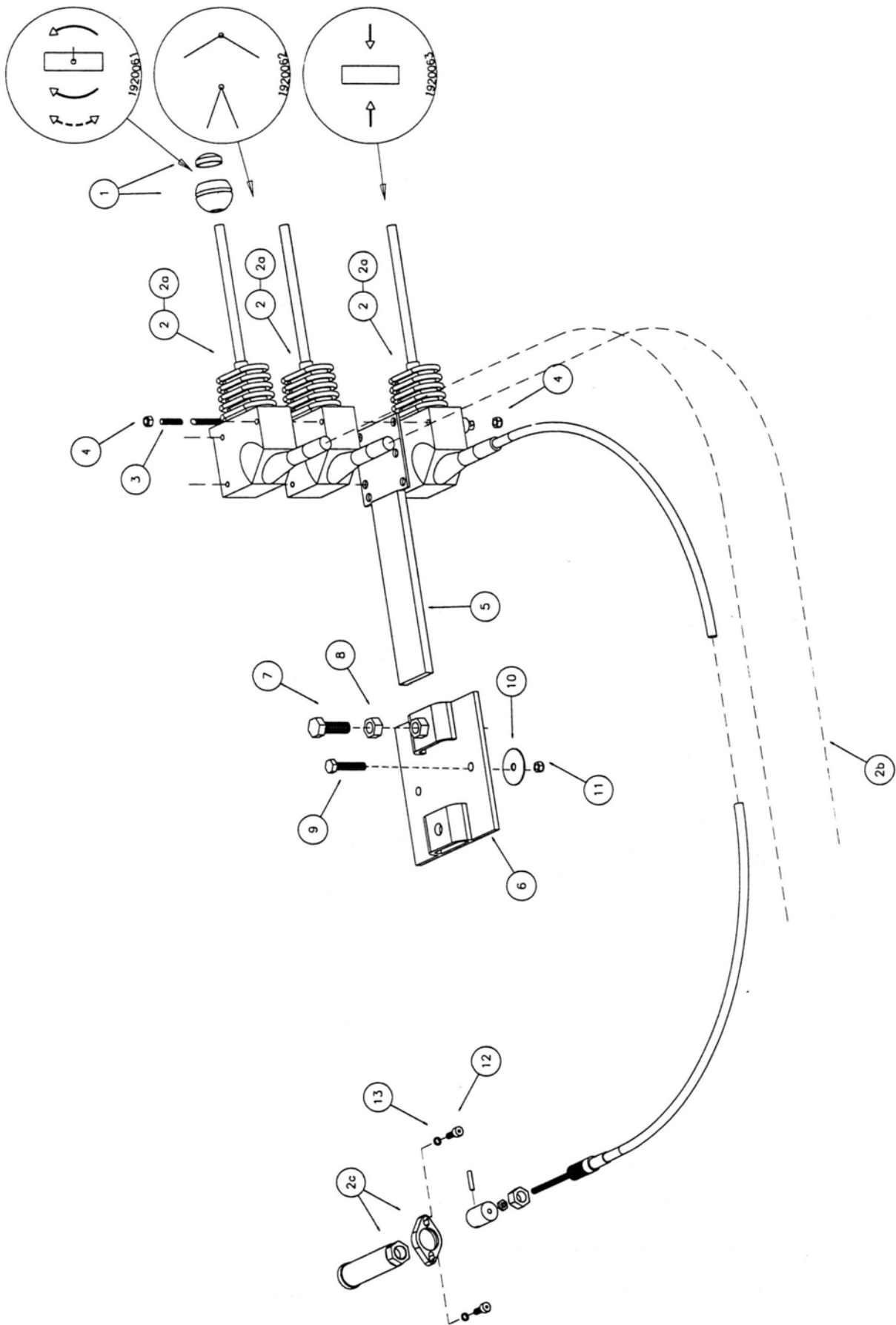

CONTROLS

<u>Ref.</u>	<u>Part No.</u>	<u>Description</u>	<u>Qty.</u>
	1920061	Transfer "Head Angle (symbol)"	1.0
	1920062	Transfer "2nd Boom (symbol)"	1.0
	1920063	Transfer "Lift (symbol)"	1.0
1	7835	Cable Control Knob and Lens Black	3.0
2	8045	Cable Control Assy 2.0m	3.0
2a	7822.2	Controller only	3.0
2b	8045.1	Cable Only - 2.0m long	3.0
2c	8045.2	Connection Kit	4.0
3	184.259F	Studding	3.0
4	4776	Nyloc Stiffnut	6.0
5	184.258	Mounting Bracket Controller	1.0
6	184.257	Fixing Bracket - Controllers	1
7	2962	Setscrew	1
8	2721	Fullnut	1
9	3730	Setscrew	2
10	3770	Washer - Mudguard	2
11	3182	Nyloc Stiffnut	2
12	4695	Setscrew - Cap Socket	8
13	2731	Washer	8

RAM VALVE & HOSES

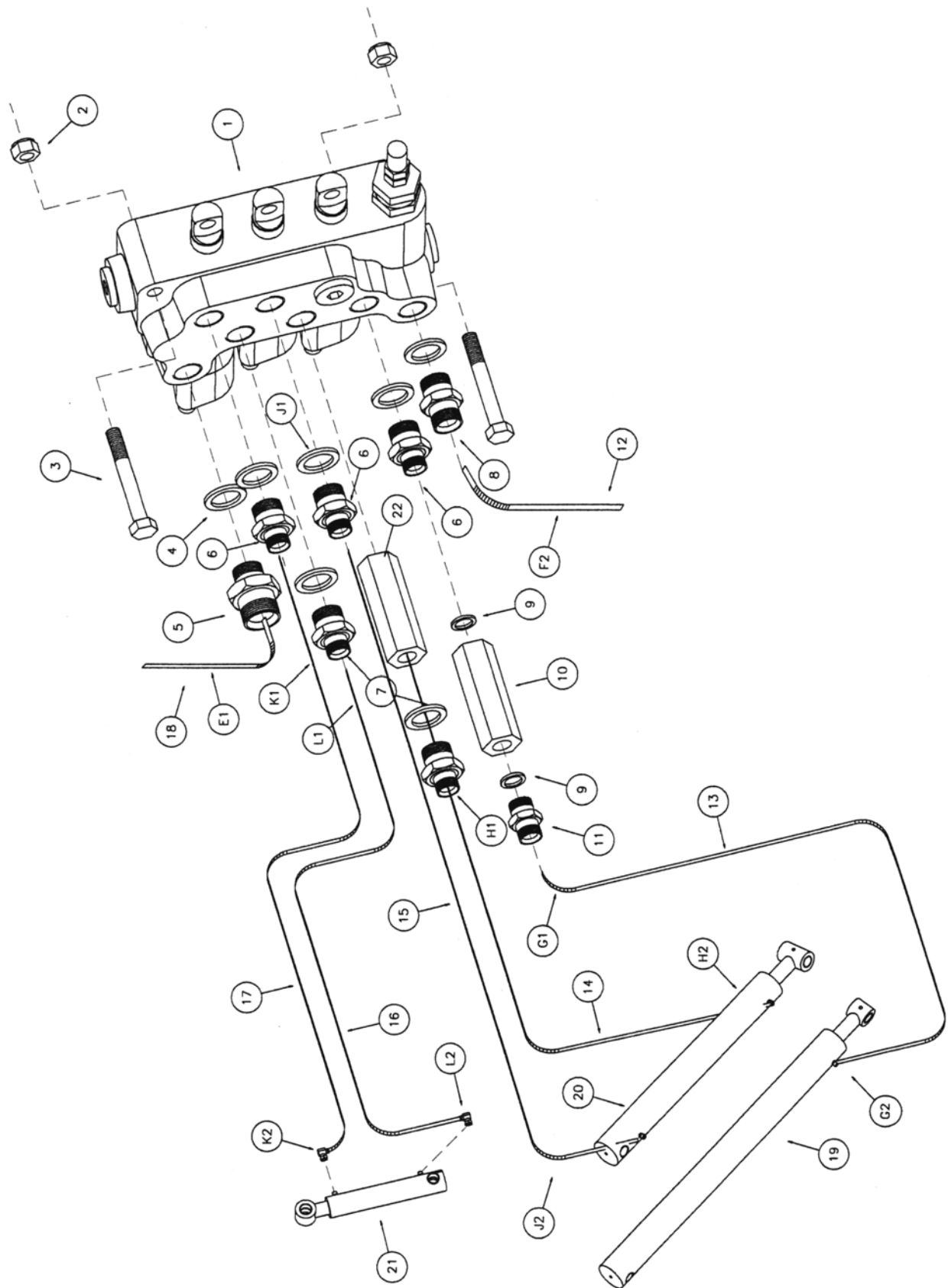

RAM VALVE & HOSES

<u>Ref.</u>	<u>Part No.</u>	<u>Description</u>	<u>Qty.</u>
1	8134	Valve block	1
2	3182	Nyloc Stiffnut	2
3	2962	Setscrew	2
4	0670	Seal - Bonded	7
5	0914	Adaptor	1
6	1180	Adaptor	3
7	7740	Adaptor	2
8	0665	Adaptor	1
9	1181	Seal - Bonded	2
10	7002	Restrictor	1
11	1823	Adaptor	1
12	004.719	Hose - 3/8" 90 x 90 x 345 @330	1
13	004.720	Hose - 1/4" 90 x 91 x 1170 @300	1
14	004.727	Hose - 1/4" 90 x 91 x 1580 @000	1
15	004.728	Hose - 1/4" 90 x 91 x 1080 @000	1
16	004.730	Hose - 1/4" 90 x 91 x 2900 @000	1
17	004.729	Hose - 1/4" 90 x 91 x 3320 @000	1
18	004.718	Hose - 1/2" 90 x 90 x 640 @000	1
19	1930001	Ram Primary	1
20	1930002	Ram Secondary	1
21	1930003	Ram Head Angling	1
22	8184	Restrictor	1

ROTOR DRIVE - VALVES & HOSES

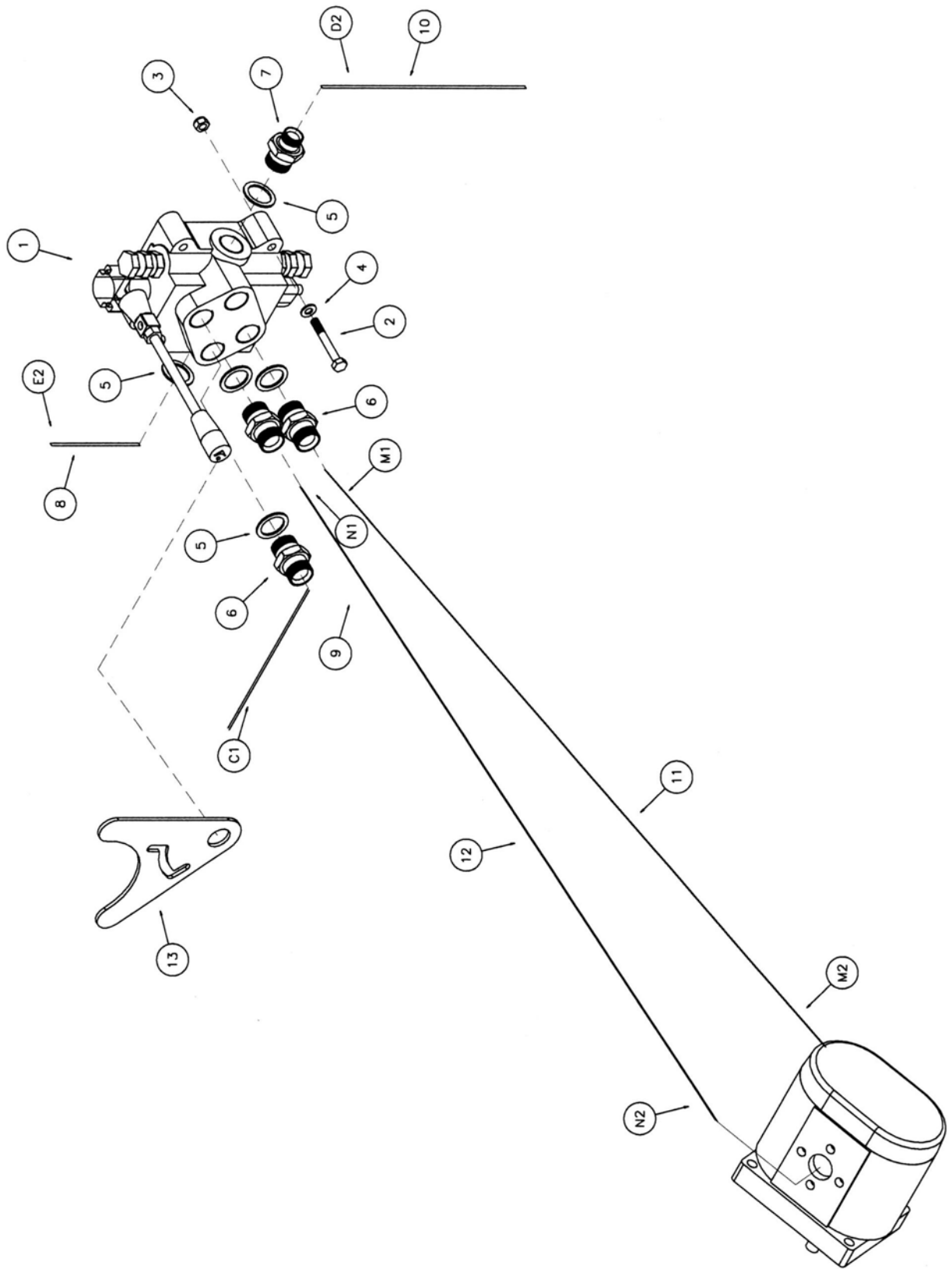

ROTOR DRIVE - VALVES & HOSES

<u>Ref.</u>	<u>Part No.</u>	<u>Description</u>	<u>Qty.</u>
1	8040 R240	Valve Block Motor Spool c/w Lever	1
2	3262	Bolt	3
3	3182	Nyloc Stiffnut	3
4	3111	Washer	3
5	0934	Seat - Bonded	5
6	0935	Adaptor	4
7	1834	Adaptor	1
8	004.718	Hose - 1/2" 90 x 90 x 640 @000	1
9	004.716	Hose - 3/4" 90 x 45 x 670 @090	1
10	004.717	Hose - 1/2" 90 x 90 x 670 @180	1
11	004.731	Hose - 3/4" ST x 90 x 4480	1
12	004.732	Hose - 3/4" 90 x 45 x 4520 @270	1
13	193-036-	Gate Detent	1

HOSE LIST

315 Models

Part No.	Description	Qty.
8501308	Hose - 1 1/2" Bore x 130mm long	1
10.010.14	Hose - 3/4" BSP FS/F90 x 700mm long	3
8501309	Hose - 3/4" BSP FS/F135 Swept x 400mm long	1
10.006.14	Hose - 1/2" BSP ST/90 x 700mm long	1
10.004.08	Hose - 3/8" BSP ST/90 x 400mm long	1
10.002.22	Hose - 1/4" BSP ST/90 x 1200mm long	1
10.002.23	Hose - 1/4" BSP ST/90 x 1300mm long	1
10.002.16	Hose - 1/4" BSP ST/90 x 800mm long	1
10.002.36	Hose - 1/4" BSP ST/90 x 2600mm long	1
10.002.32	Hose - 1/4" BSP FS/F90 x 2200mm long	1
10.009.48	Hose - 3/4" BSP FS/FS x 3800mm long	2

395 Models

Part No.	Description	Qty.
8501308	Hose - 1 1/2" Bore x 130mm long	1
10.010.14	Hose - 3/4" BSP FS/F90 x 700mm long	3
8501309	Hose - 3/4" BSP FS/F135 Swept x 400mm long	1
10.006.14	Hose - 1/2" BSP ST/90 x 700mm long	1
10.004.08	Hose - 3/8" BSP ST/90 x 400mm long	1
10.002.22	Hose - 1/4" BSP ST/90 x 1200mm long	1
10.002.26	Hose - 1/4" BSP ST/90 x 1600mm long	1
10.002.21	Hose - 1/4" BSP ST/90 x 1100mm long	1
10.002.43	Hose - 1/4" BSP FS/F90 x 3300mm long	1
10.002.39	Hose - 1/4" BSP ST/90 x 2900mm long	1
10.009.55	Hose - 3/4" BSP FS/FS x 4500mm long	2