



TRM6 & TRM8  
Roller Mowers  
Operation & Parts Manual

Publication 540

November 2009



# IMPORTANT VERIFICATION OF WARRANTY REGISTRATION



## DEALER WARRANTY INFORMATION & REGISTRATION VERIFICATION

It is imperative that the selling dealer registers this machine with Twose of Tiverton Limited before delivery to the end user – failure to do so may affect the validity of the machine warranty.

To register machines go to the Twose web site at [www.twose.com](http://www.twose.com), log onto 'Dealer Inside' and select the 'Machine Registration button' which can be found in the Service Section of the site. Confirm to the customer that the machine has been registered in the section below.

Should you experience any problems registering a machine in this manner please contact the Twose Office on 01884 253691.

### Registration Verification

Dealer Name: .....
Dealer Address: .....
Customer Name: .....
Date of Warranty Registration: ...../...../..... Dealer Signature: .....

### NOTE TO CUSTOMER / OWNER

*Please ensure that the above section above has been completed and signed by the selling dealer to verify that your machine has been registered with Twose of Tiverton Limited.*

**IMPORTANT:** During the initial 'bedding in' period of a new machine it is the customer's responsibility to regularly inspect all nuts, bolts and hose connections for tightness and re-tighten if required. New hydraulic connections occasionally weep small amounts of oil as the seals and joints settle in – where this occurs it can be cured by re-tightening the connection – *refer to torque settings chart below*. The tasks stated above should be performed on an hourly basis during the first day of work and at least daily thereafter as part of the machines general maintenance procedure.

### TORQUE SETTINGS FOR HYDRAULIC FITTINGS

HYDRAULIC HOSE ENDS		
BSP	Setting	Metric
1/4"	18 Nm	19 mm
3/8"	31 Nm	22 mm
1/2"	49 Nm	27 mm
5/8"	60 Nm	30 mm
3/4"	80 Nm	32 mm
1"	125 Nm	41 mm
1.1/4"	190 Nm	50 mm
1.1/2"	250 Nm	55 mm
2"	420 Nm	70 mm

PORT ADAPTORS WITH BONDED SEALS		
BSP	Setting	Metric
1/4"	34 Nm	19 mm
3/8"	47 Nm	22 mm
1/2"	102 Nm	27 mm
5/8"	122 Nm	30 mm
3/4"	149 Nm	32 mm
1"	203 Nm	41 mm
1.1/4"	305 Nm	50 mm
1.1/2"	305 Nm	55 mm
2"	400 Nm	70 mm

# WARRANTY POLICY

## WARRANTY REGISTRATION

All machines must be registered, by the selling dealer with Twose of Tiverton Ltd, before delivery to the end user. On receipt of the goods it is the buyer's responsibility to check that the Verification of Warranty Registration in the Operator's Manual has been completed by the selling dealer.

### 1. LIMITED WARRANTIES

- 1.01. *All machines supplied by Twose of Tiverton Ltd are warranted to be free from defects in material and workmanship from the date of sale to the original purchaser for a period of 12 months, unless a different period is specified.*
- 1.02. *All spare parts supplied by Twose of Tiverton Ltd and purchased by the end user are warranted to be free from defects in material and workmanship from the date of sale to the original purchaser for a period of 6 months. All parts warranty claims must be supported by a copy of the failed part invoice to the end user. We cannot consider claims for which sales invoices are not available.*
- 1.03. *The warranty offered by Twose of Tiverton Ltd is limited to the making good by repair or replacement for the purchaser any part or parts found, upon examination at its factory, to be defective under normal use and service due to defects in material or workmanship. Returned parts must be complete and unexamined. Pack the component(s) carefully so that any transit damage is avoided. All ports on hydraulic items should be drained of oil and securely plugged to prevent seepage and foreign body ingress. Certain other components, electrical items for example, may require particular care when packing to avoid damage in transit.*
- 1.04. *This warranty does not extend to any product from which Twose of Tiverton Ltd's serial number plate has been removed or altered.*
- 1.05. *This warranty does not apply to any part of the goods, which has been subjected to improper or abnormal use, negligence, alteration, modification, fitment of non-genuine parts, accident damage, or damage resulting from contact with overhead power lines, damage caused by foreign objects (e.g. stones, iron, material other than vegetation), failure due to lack of maintenance, use of incorrect oil or lubricants, contamination of the oil, or which has served its normal life. This warranty does not apply to any expendable items such as blades, belts, clutch linings, filter elements, flails, flap kits, skids, soil engaging parts, shields, guards, wear pads, pneumatic tyres or tracks.*
- 1.06. *Temporary repairs and consequential loss - i.e. oil, downtime and associated parts are specifically excluded from the warranty.*
- 1.07. *Warranty on hoses is limited to 12 months and does not include hoses which have suffered external damage. Only complete hoses may be returned under warranty, any which have been cut or repaired will be rejected.*
- 1.08. *Machines must be repaired immediately a problem arises. Continued use of the machine after a problem has occurred can result in further component failures, for which Twose of Tiverton Ltd cannot be held liable, and may have safety implications.*
- 1.09. *If in exceptional circumstances a non Twose of Tiverton Ltd part is used to effect a repair, warranty reimbursement will be at no more than Twose of Tiverton Ltd's standard dealer cost for the genuine part.*
- 1.10. *Except as provided herein, no employee, agent, dealer or other person is authorised to give any warranties of any nature on behalf of Twose of Tiverton Ltd.*
- 1.11. *For machine warranty periods in excess of 12 months the following additional exclusions shall apply:*
  - 1.11.1. *Hoses, exposed pipes and hydraulic tank breathers.*
  - 1.11.2. *Filters.*
  - 1.11.3. *Rubber mountings.*
  - 1.11.4. *External electric wiring.*
  - 1.11.5. *Bearings and seals.*

- 1.12. All service work, particularly filter changes, must be carried out in accordance with the manufacturer's service schedule. Failure to comply will invalidate the warranty. In the event of a claim, proof of the service work being carried out may be required.
- 1.13. Repeat or additional repairs resulting from incorrect diagnosis or poor quality previous repair work are excluded from warranty.

**NB Warranty cover will be invalid if any non-genuine parts have been fitted or used. Use of non-genuine parts may seriously affect the machine's performance and safety. Twose of Tiverton Ltd cannot be held responsible for any failures or safety implications that arise due to the use of non-genuine parts.**

## **2. REMEDIES AND PROCEDURES**

- 2.01. The warranty is not effective unless the Selling Dealer registers the machine, via the Twose of Tiverton Ltd web site and confirms the registration to the purchaser by completing the confirmation form in the operator's manual.
- 2.02. Any fault must be reported to an authorised Twose of Tiverton Ltd dealer as soon as it occurs. Continued use of a machine, after a fault has occurred, can result in further component failure for which Twose of Tiverton Ltd cannot be held liable.
- 2.03. Repairs should be undertaken within two days of the failure. Claims submitted for repairs undertaken more than 2 weeks after a failure has occurred, or 2 days after the parts were supplied will be rejected, unless the delay has been authorised by Twose of Tiverton Ltd. Please note that failure by the customer to release the machine for repair will not be accepted as a reason for delay in repair or submitting warranty claims.
- 2.04. All claims must be submitted, by an authorised Twose of Tiverton Ltd Service Dealer, within 30 days of the date of repair.
- 2.05. Following examination of the claim and parts, Twose of Tiverton Ltd will pay, at their discretion, for any valid claim the invoiced cost of any parts supplied by Twose of Tiverton Ltd and appropriate labour and mileage allowances if applicable.
- 2.06. The submission of a claim is not a guarantee of payment.
- 2.07. Any decision reached by Twose of Tiverton Ltd is final.

## **3. LIMITATION OF LIABILITY**

- 3.01. Twose of Tiverton Ltd disclaims any express (except as set forth herein) and implied warranties with respect to the goods including, but not limited to, merchantability and fitness for a particular purpose.
- 3.02. Twose of Tiverton Ltd makes no warranty as to the design, capability, capacity or suitability for use of the goods.
- 3.03. Except as provided herein, Twose of Tiverton Ltd shall have no liability or responsibility to the purchaser or any other person or entity with respect to any liability, loss, or damage caused or alleged to be caused directly or indirectly by the goods including, but not limited to, any indirect, special, consequential, or incidental damages resulting from the use or operation of the goods or any breach of this warranty. Notwithstanding the above limitations and warranties, the manufacturer's liability hereunder for damages incurred by the purchaser or others shall not exceed the price of the goods.
- 3.04. No action arising out of any claimed breach of this warranty or transactions under this warranty may be brought more than one (1) year after the cause of the action has occurred.

## **4. MISCELLANEOUS**

- 4.01. Twose of Tiverton Ltd may waive compliance with any of the terms of this limited warranty, but no waiver of any terms shall be deemed to be a waiver of any other term.
- 4.02. If any provision of this limited warranty shall violate any applicable law and is held to be unenforceable, then the invalidity of such provision shall not invalidate any other provisions herein.
- 4.03. Applicable law may provide rights and benefits to the purchaser in addition to those provided herein.





## **Twose of Tiverton Limited**

6 Chinon Court,  
Lower Moor Way,  
Tiverton Business Park,  
Tiverton,  
Devon. EX16 6SS.  
Telephone: (01884) 253691  
Fax: (01884) 255189  
Email [sales@twose.com](mailto:sales@twose.com)  
Web: [www.twose.com](http://www.twose.com)



# DECLARATION OF CONFORMITY

*Conforming to EU Machinery Directive 2006/42/EC*

We,

**TWOSE of TIVERTON LIMITED,**  
6 Chinon Court, Lower Moor Way,  
Tiverton Business Park, Tiverton, Devon, EX16 6SS, UK

*Hereby declare that:*

The Product; *Tractor Mounted Rotary Finishing Mower*

Product Code; *RM18, RM24*

Serial No. & Date ..... Type .....

Manufactured in; *United Kingdom*

Complies with the required provisions of the Machinery Directive 2006/42/EC  
The machinery directive is supported by the following harmonized standards;

- BS EN ISO 12100 (2010) Safety of machinery – General principles for design – Risk assessment and risk reduction.
- BS EN 349 (1993) + A1 (2008) Safety of machinery - Minimum distances to avoid the entrapment with human body parts.
- BS EN 953 (1997) + A1 (2009) Safety of machinery - Guards general requirements for the design and construction of fixed and movable guards.
- BS EN 4413 (2010) Hydraulic fluid power. Safety requirements for systems and their components.

Signed  ..... *Responsible Person*  
*CHRISTIAN DAVIES on behalf of TWOSE OF TIVERTON LIMITED*

Status: *General Manager*

Date: *September 2015*



# LIST OF CONTENTS

---

## **Operator Section**

General Information	1
Machine Description	2
Machine Identification	2
Technical Specification	2
Safety Information	3
Machine Guards & Component Locations	5
Pre-Installation & Handling	5
Attachment, Detachment & Storage	6
Fitting PTO Drive Shaft	7
PTO Shaft Length Adjustment	8
Special Instructions for Rough Terrain Operation	8
Adjustment & Setup	9
Use & Operation	11
Machine Maintenance	12
Torque Setting Chart	13

## **Parts Section**

Main Assemblies – <i>TRM6</i>	15
Main Assemblies – <i>TRM8</i>	16
Deck Assembly – <i>TRM6</i>	17
Deck Assembly – <i>TRM8</i>	19
Drive Assembly – <i>TRM6</i>	21
Drive Assembly – <i>TRM8</i>	23
Blade & Shaft Assembly – <i>TRM6 &amp; TRM8</i>	25
A-Frame Assembly – <i>TRM6 &amp; TRM8</i>	27
Side Skid Assembly – <i>TRM6 &amp; TRM8</i>	29
Decals	31

## GENERAL INFORMATION

---

*Always read this manual before fitting or operating the machine – whenever any doubt exists contact your dealer or the Twose Service Department for advice and assistance.*

### **Use only Twose Genuine Service Parts on Twose Equipment and Machines**

**DEFINITIONS** – The following definitions apply throughout this manual:

#### **WARNING**

An operating procedure, technique etc., which –  
can result in personal injury or loss of life if not observed carefully.

#### **CAUTION**

An operating procedure, technique etc., which –  
can result in damage to either machine or equipment if not observed carefully.

#### **NOTE**

An operating procedure, technique etc., which –  
is considered essential to emphasis.

#### **LEFT AND RIGHT HAND**

This term is applicable to the machine when attached to the tractor and is viewed  
from the rear – this also applies to tractor references.

## MACHINE & DEALER INFORMATION

***Record the Serial Number of your machine on this page and always quote this number when ordering parts. Whenever information concerning the machine is requested remember also to state the make and model of tractor to which the machine is fitted.***

<b>Machine Serial Number:</b>	<b>Installation Date:</b>
<b>Machine Model details:</b>	
<b>Dealer Name:</b>	
<b>Dealer Address:</b>	
<b>Dealer Telephone No:</b>	
<b>Dealer Email Address:</b>	

## MACHINE DESCRIPTION & PURPOSE OF USE

---

The TRM6 & TRM8 Series of Rotary Finishing Mowers are primarily designed for turf and grass maintenance in areas such as parks and playing fields. Their lightweight design and low power requirement make them best suited to small tractors. Any other use is considered improper and the manufacturer disclaims all responsibility for any consequential injuries to people or for damage to the machine caused by improper use or failure to adhere to the safety and maintenance information provided.

*These machines should only be used to perform tasks for which they were designed – use of the machine for any other function may be both dangerous to persons and damaging to components and is therefore not advisable.*

## MACHINE IDENTIFICATION

---

Each machine is fitted with an identification plate with the following information:

1. Machine (Part Number)
2. Machine Serial No.
3. Machine Weight

When ordering spares or replacement parts from your local dealer it is important to quote both Part Number and Serial Number as stated on the identification plate so the machine and model can be quickly and correctly identified.

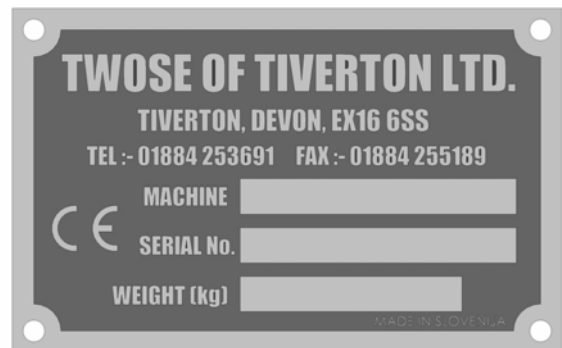

**Machine Identification Plate**

## TECHNICAL SPECIFICATIONS

---

Specification	TRM6	TRM8
Width of Cut	1860mm	2460mm
Min. Tractor Power req'd	25kw / 32hp	30kw / 40hp
PTO Speed ( <i>max</i> )	540 rpm	540 rpm
Weight	540 kg	646 kg
Tractor Attachment	Cat. 1& Cat. 2	Cat. 1& Cat. 2
No. of Blades Spindles	3	4
Height of Cut ( <i>min / max</i> )	12mm / 90mm	12mm / 90mm
Overall Width	2020mm	2620mm
Length	1520mm	1520mm
Blade Tip Speed	86m/s	86m/s
Blade Overlap	38mm	38mm

## SAFETY INFORMATION

---

### General safety rules:

- ▲ Always read and follow the instructions for the use and maintenance of the machine before carrying out any work operations or servicing tasks.
- ▲ Improper use of the machine is both highly dangerous to persons and damaging to the machine components – only use the machine for its designated task.
- ▲ Both operators and the maintenance fitters should be familiar with the machine and fully aware of dangers surrounding improper use or incorrect repairs.
- ▲ Before starting, checks to both tractor and machine must be carried out as regards: functionality, road safety, accident prevention rules.
- ▲ Even when using the machine correctly, stones or other objects may be thrown a long distance. Therefore nobody must stand within the danger area. Special attention must be paid when working near roads or buildings.
- ▲ Use tractor's fitted with safety cabs.
- ▲ The condition of flails and of machine guards must be checked before beginning the daily work - they must be replaced if damaged or missing before you use the machine.
- ▲ During checks or repairs, ensure nobody can start the machine by mistake.
- ▲ Never wear loose or fluttering clothes.
- ▲ Never carry passengers on the tractor.
- ▲ Never carry passengers on the machine.
- ▲ Never connect the power takeoff with the engine running.
- ▲ Never approach the machine until the rotor has completely stopped.
- ▲ Do not enter the working zone of the PTO shaft. It is dangerous to approach the rotating parts of a machine.
- ▲ Keep the PTO shaft guard in good condition.
- ▲ Before starting, check the surrounding area for the likely presence of children and/or animals.
- ▲ Do not stand near the machine when it is operating.
- ▲ The PTO shaft must be assembled and disassembled only with the engine stopped and the starting key removed.
- ▲ Before connecting the power takeoff, check that the speed and the rotational direction correspond to those of the machine.
- ▲ Immediately replace missing or damaged safety decals.
- ▲ Before leaving the tractor with the machine attached, proceed as follows:
  1. Disconnect the power takeoff,
  2. Put the machine steadily on the ground using the tractor's hydraulic lift.
  3. Apply the hand brake and, if the ground is steeply sloping, wedge the tractor.
  4. Remove the starting key.

## **Transportation Safety**

- ▲ In transport, reduce speed, especially on bumpy roads, the weight of the machine may render driving difficult and damage the machine itself.
- ▲ Ensure the levers that operate the hydraulic lift are locked, to avoid the lowering of the machine during transport.
- ▲ When driving on public roads, respect all road rules in force.
- ▲ Never transport the machine with the rotor running, even for short distances.

## **Operating Safety**

- ▲ Pay special attention when working with the machine not to touch fixed objects such as road drain, walls, shafts, kerbs, guard rails, tracks etc. This could cause the breakage of the blades, which would be thrown out of the machine at very high speed.
- ▲ If wires, ropes or chains should become entangled in the rotor stop immediately to prevent damage or dangerous situations; stop the rotor and the tractor, take out the starting key. Put working gloves on; clear the rotor with the aid of pliers or shears. Do not try to disentangle by inverting the rotational direction of the rotor.
- ▲ Do not use the machine when excessive vibration is experienced, as this may cause breakage and serious damage - find the cause of the vibration and eliminate it before using the machine again.

---

**Although the information given here covers a wide range of safety subjects, it is impossible to predict every eventuality that can occur under differing circumstances whilst operating this machine. No advice given here can replace 'good common sense' and 'total awareness' at all times, but will go a long way towards the safe use of your Twose machine.**

---

## MACHINE GUARDS & COMPONENT LOCATIONS

---

1. Belt, Pulley & Drive Guard
2. Front & Rear Rubber Skirts
3. PTO Shaft Guard
4. Side Skids
5. Front & Rear Roller
6. A-Frame
7. PTO Shaft

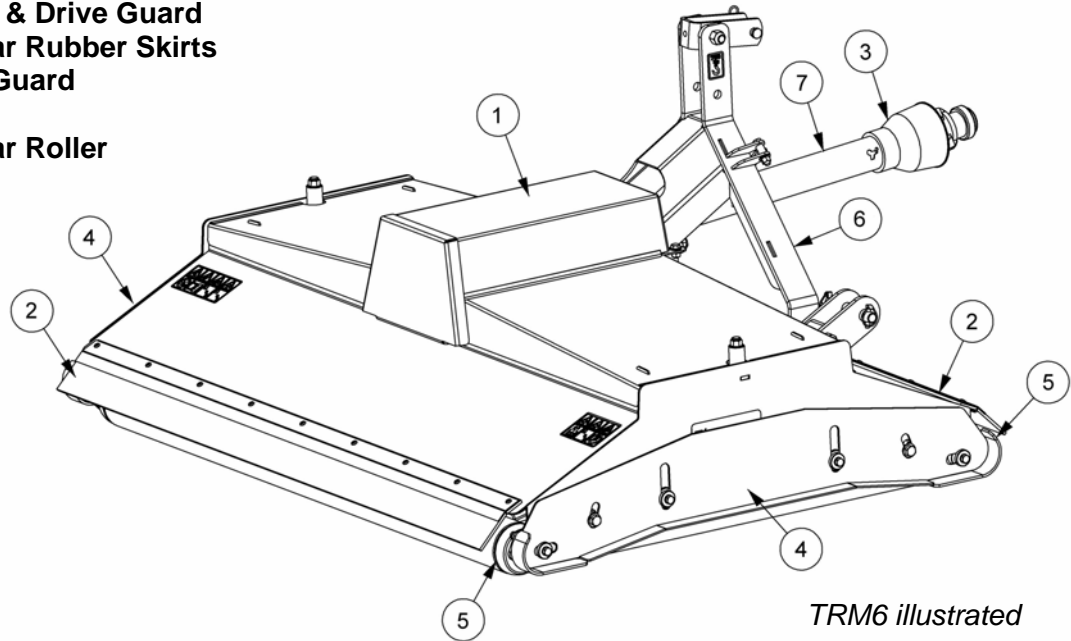

## PRE-INSTALLATION AND HANDLING INSTRUCTIONS

---

### Lifting and Unloading

To handle the machine, use an elevator with a lifting capability suitable to the weight of the machine.

### Pre-Attachment

Before attaching the machine to the tractor for use it is mandatory to;

- Visually check the condition of the machine in general.
- Ensure all guards are fitted correctly and are in good condition.
- Ensure Blades are fitted correctly and are in good condition.
- Grease bearings and any other part as indicated by a decal.
- Check that the number of revolutions and the rotational direction of the PTO correspond to the requirement of the machine.

## ATTACHMENT, DETACHMENT & STORAGE

---

### Attaching the Machine

- With the tractor and machine on firm level ground, back the tractor up to the machine so that the lower draft links are in alignment with the machines lower lift pins
- Place tractor in park, switch off engine and remove key.
- Connect the tractor and stabiliser bars to the lower lift pins.
- Lock the parallel links of the power lift with the relative chains and rods on the tractor to prevent the coupled machine from moving in a horizontal direction.
- Fit the driveline to the power takeoff on the tractor making sure it has seated in the correct position and that it is free to turn and fixed with the relative latches, both on the tractor and on the machine. *Refer to following page for details of PTO fitment.*
- Connect the top link and adjust as necessary to achieve alignment with the ground.

*With both tractor and mower on firm level ground adjust the top link to give an angle at 'A' of approx. 45° so that the mower (sitting on its rollers) is able to follow ground undulations behind the tractor, both up and down - Refer to diagram below.*

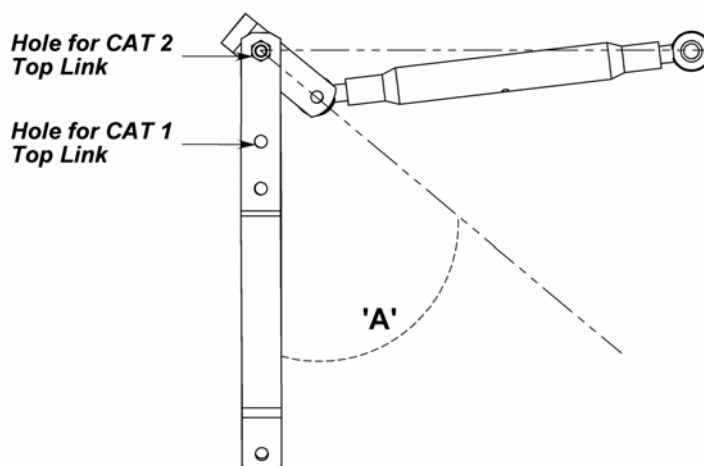

### Detaching the Machine

Detachment of the machine is a reversal of the procedure above. Ensure the site chosen for machine detachment is a firm, level location for both safe parking and subsequent ease of re-attachment. Chock rollers to prevent any risk of machine movement whilst parked.

### Machine Storage

The machine should be stored in a clean, dry environment where it is protected from the elements. Clean and lubricate the machine prior to storage, and inspect for damaged and/or missing components so they can be pre-ordered and fitted ready for the next seasons work. Ensure the machine is parked safely at all times with no risk of moving or falling.

## FITTING THE PTO DRIVE SHAFT

### WARNING!

A loose shaft could slip off resulting in personal injury or damage to the machine. When attaching PTO yoke to tractor PTO shaft ensure that the spring activated locking collar slides freely and that the locking balls are seated in the groove on PTO shaft.

NOTE: QS-lock is fully engaged if collar can be rotated freely.

### WARNING!

Before operating mower:

Check to make sure the driveline will not 'bottom out' or become disengaged.

- Disengage the driveline from the tractor PTO shaft.
- Slide the driveline together until it 'bottoms out' solidly. Extend shaft 40mm, then apply coloured tape level with outer tube shield – *this shows minimum shaft length*.
- Slide driveline apart until  $\frac{1}{2}$  PU length of inner shaft shield is exposed, see *diagram below*, apply coloured tape level with outer tube shield as before, this then indicates maximum shaft length.
- Re-attach driveline to tractor PTO shaft.

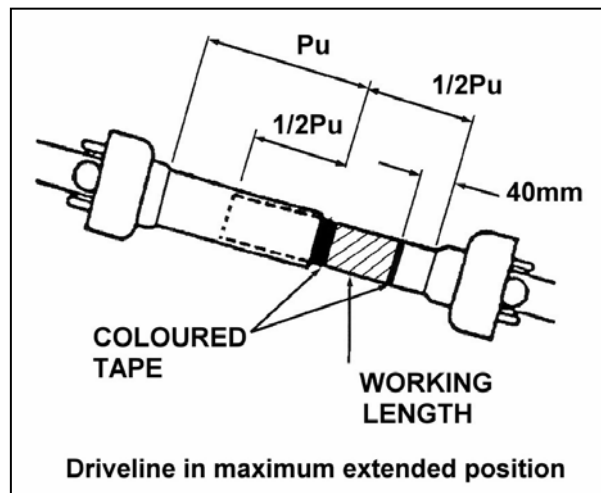

With the PTO disengaged (not turning), slowly drive the tractor with mower attached through the most severe terrain conditions expected and watch shaft movement. The end of the outer shield should always be located between the tape markers.

Check position which places driveline at maximum extended length and at minimum compressed length – *the minimum compressed length should always maintain at least 40mm (1-9/16") clearance, if not shorten as described in the following page.*

If driveline cannot be shortened and still maintain  $\frac{1}{2}$  PU dimension engagement when at maximum extended length, then the operator should be aware of it, so that they can recognise the terrain conditions that might cause problems i.e. avoiding possible damage by disconnecting driveline from tractor and/or crossing the terrain in a different manner. If driveline is shortened, re-apply the coloured tapes and re-check length, as above.

See special instructions for rough terrain operations on following page.



## PTO Shaft Length Adjustment

1. Shorten outer plastic tube to 40mm less than shortest envisaged PTO shaft length.
2. Remove the marked tube, ensure a square cut.
3. Remove same length from inner plastic tube and metal shaft profiles (inner & outer).
4. De-burr all edges and remove swarf to ensure smooth operation.

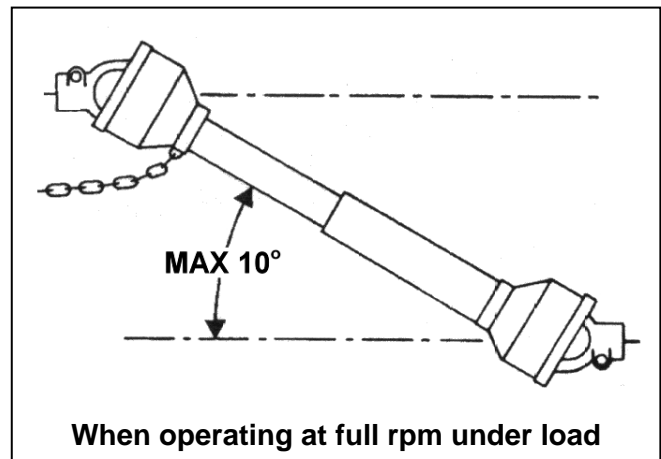
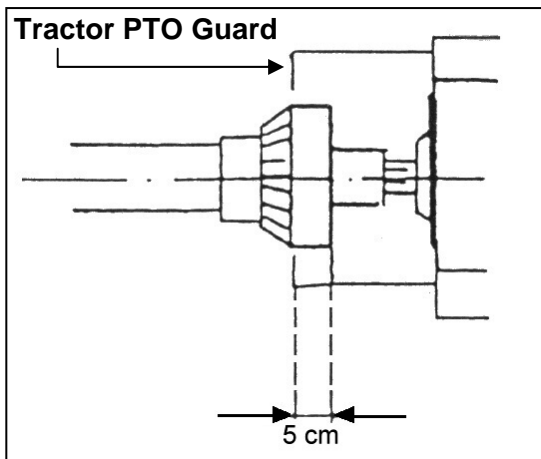
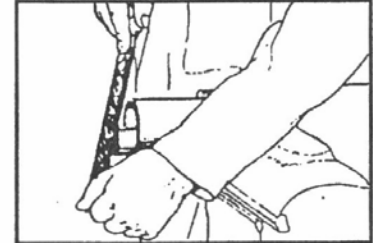
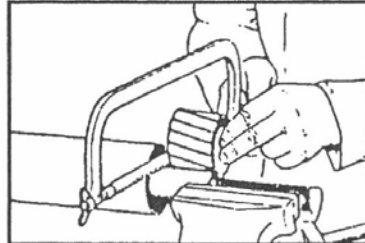
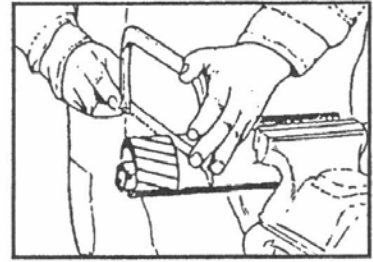
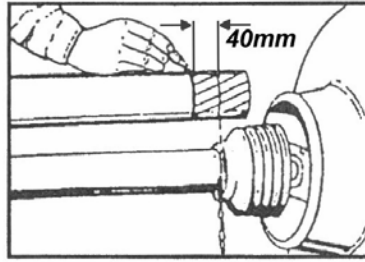

## Special Instructions for Rough Terrain Operations

When crossing ditches with steep banks or manoeuvring up sharp inclines it is possible to 'bottom out' the driveline that connects the tractor PTO to the gearbox on the mower.

To 'bottom out' means that the inner shaft has penetrated into the outer housing to its maximum depth until the assembly becomes solid – it can shorten no more (see *diagram opposite*). If this happens, it can cause serious damage to the tractor PTO by pushing the PTO into the tractor through the support bearings or downward onto the PTO shaft, breaking it off.

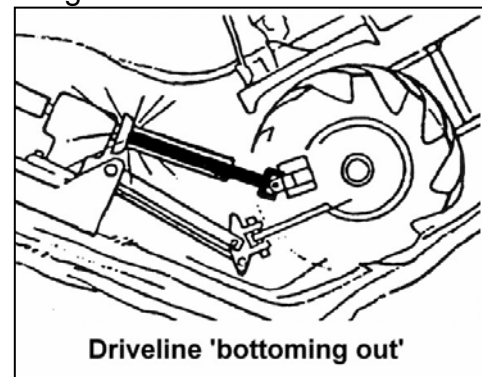

### WARNING!

Either failure can allow the driveline to come loose from the tractor which could cause bodily injury to the operator or others in the vicinity in addition to expensive damage to the tractor and/or mower.

If you have a condition where your tractor will be manoeuvring up a steep incline whilst the mower remains on flat ground or coming down the opposite incline, you have a potential problem. The correct preventative measure is to cross this type of terrain at an angle, *refer to diagrams below*. This will reduce the angle between the tractor and the mower.

**CORRECT**

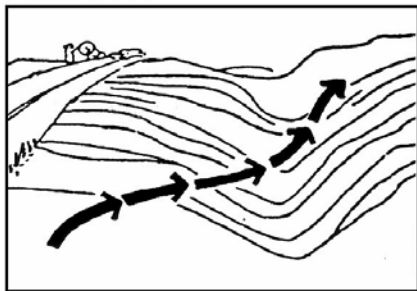

**Approach ditch at angle**

**INCORRECT**

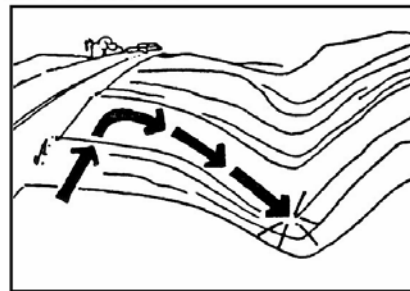

**DO NOT approach ditch straight on**

**Tractor Stability**

Due to the design of mowers and the work they do, it is essential to ensure tractor stability in order to eliminate any risk of imbalance or overturning. Lift the machine and check that it does not mount up, if imbalance is detected it should be counteracted by the fitting of suitable ballast weights.

**Parking**

Parking of the tractor and machine should be in a safe place away from risk on a firm, flat surface with the mower lowered to the ground to prevent rolling over or falling. Never park up and leave the machine raised. Remove the tractor key before leaving the tractor and machine.

**ADJUSTMENT & SETUP**

**Cutting Height Adjustment**

Adjustment to the cutting height is achieved by means of raising or lowering the front and rear rollers. The procedure for adjusting the cutting height is as follows;

- With the mower coupled to the tractor, raise the mower with the power lift to a position that will enable adjustment of the rollers.

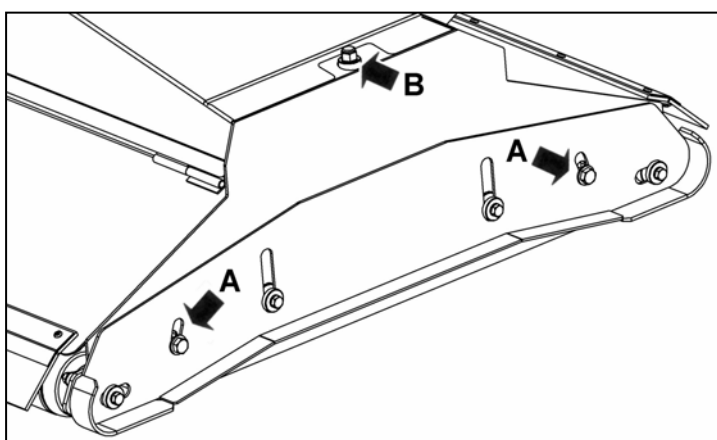

**A) Adjustment Locking Bolts**

**B) Height Adjustment Bolt**

- Turn off the tractor engine, engage the parking brake, remove and pocket the key.

**CAUTION!**  
Ensure that no part of your body is under the machine as the machine will be unpropped.

- Working on one side of the mower at a time, slacken the height adjustment locking bolts and adjust roller height with the top adjustment bolt, retighten locking bolts when correct height has been achieved - *refer to decal on machine.*
- Repeat procedure for other side. Ensure adjustments made are the same for both sides of the mower.

**Note for easiest roller height adjustment;**

To raise the cutting height; *raise mower clear of ground to adjust so you are lowering the weight of the rollers.*

To lower the cutting height; *adjust with mower on the ground so you are lowering the weight of the deck.*

**Belt Adjustment**

The two belts are adjusted independently as follows;

- Slacken locknut **1** only sufficient enough to allow the pulley to move in the slot.
- Back off locknut **2**.
- Tension belt by adjustment of nut **3** to correct deflection – *see note below.*
- Re-tighten all locking nuts, and re-check belt tension.

**NOTE;** It is important to pull the belt ‘around’ by hand as it is being tensioned to allow the belt to ‘creep’ on the drive pulley – tightening the belt without pulling it round will over tension the belt between drive and centre pulley causing premature failure of the belt.

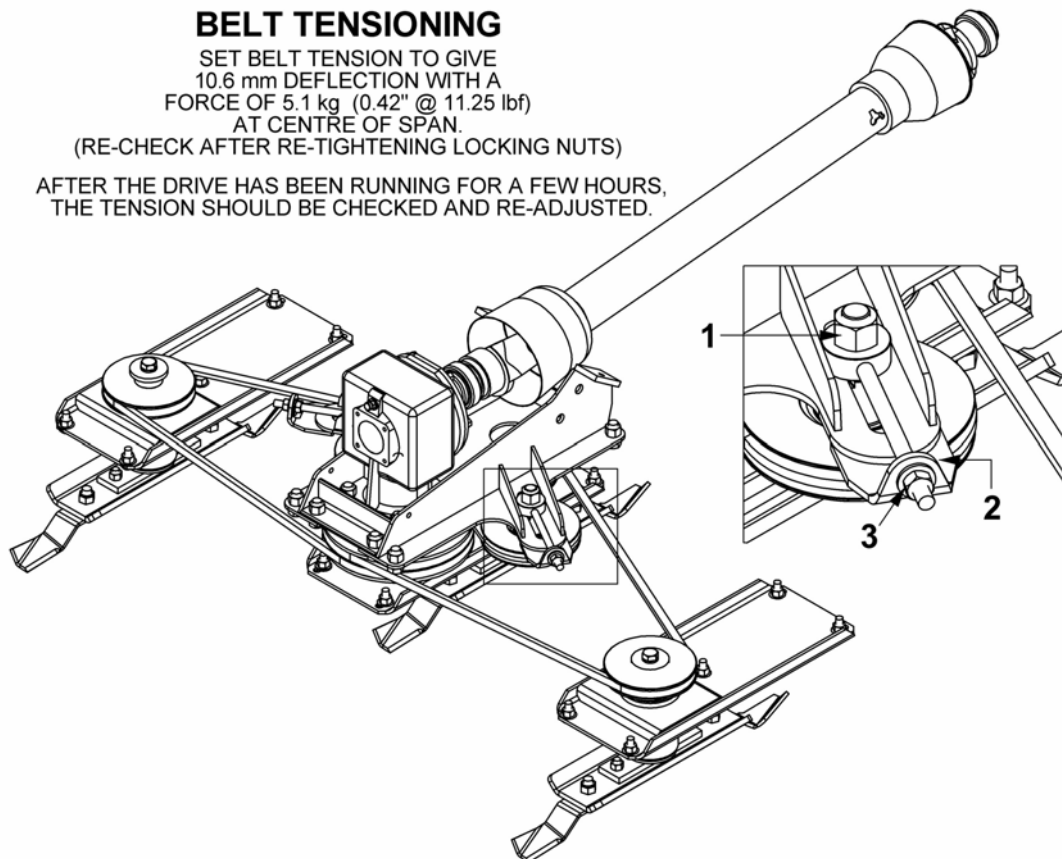

## USE AND OPERATION

---

### Starting

Before using the machine ensure that you, and all other operators, have read and fully understood this entire manual, and that you are familiar with all aspects relating to correct use of this mower with the emphasis on safety.

Before beginning work:

- Check oil level in Gearbox before starting.
- Check all parts for signs of wear or deterioration, replace if worn or damaged.
- Ensure all guards are in position and in good condition.
- Check PTO rpm and rotational direction corresponds to machine – *refer to gearbox decal for details.*
- Always engage PTO at low engine rpm to avoid damage to gearbox and belts.

### Working

- Adjust the machines cutting height to suit the type of work to be done and the materials to be cut.
- Work at a speed to suit the materials to be cut and the degree of chopping required – *optimum speed range is from 3 to 8 km/h (2-6 mph)*
- Start tractor and raise mower before engaging PTO, allow mower to achieve working speed and lower onto material to be cut.
- After a short distance mowing, check that the grass is being cut to the desired height.

### Stopping

- Lower machine to the ground.
- Disconnect the PTO.
- Stop the tractor, apply handbrake and remove the key. If the ground is sloping block tractor wheels.

### Transport Position

During transportation of the machine ensure the following;

- Observe all road transport regulations and display all necessary warning signs.
- Reduce speed especially on bumpy or uneven roads as the weight of the machine may render driving difficult and damage the machine itself.
- Always disengage the PTO.

## MACHINE MAINTENANCE

---

All maintenance, cleaning, and repair operations must be carried out with the machine firmly lowered to the ground and detached from the tractor, or with the PTO disconnected, engine off, and the starting key removed.

### Initial Checks

After the first two hours of operation from new, or after the fitting of new belts, check the belt tension.

Check the level of the oil in the gearbox after the first 10 hours of operation – *the level is correct when it reaches the lower edge of the plug hole at the side of the housing.* If 'top up' with oil is required, pour it through the fill hole after having unscrewed the vent plug. Refit the fill plug and the vent plug on completion of this operation.

### Regular Maintenance

#### Every 8 hours of work

- Ensure the nuts that fix the blades to the rotors are firmly torqued.
- Grease the PTO shaft.
- Check Gearbox Oil level – Top up if required using SAE 90EP oil - fill to level hole on side of gearbox.
- Ensure blades are in good condition, replace worn or damaged blades (in pairs) immediately; *Replacement of blades requires the mower to be raised, and supported in position, with strong, suitable stands.*

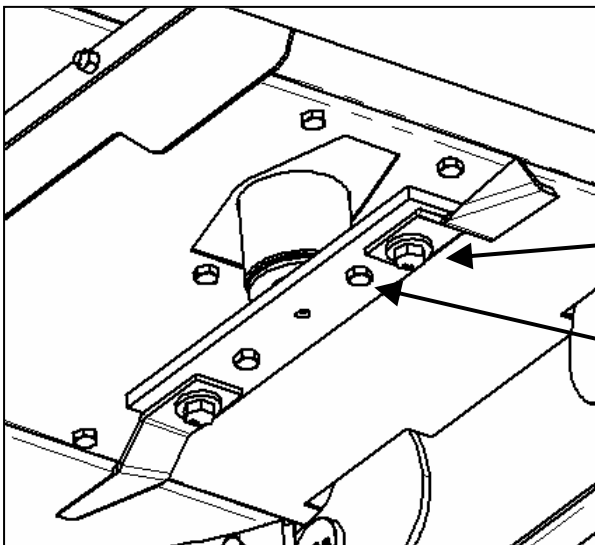

Check blade pivot bolts and nuts are tightened to correct torque settings.

Ensure blade carrier bolts/nuts are tight.

*Refer to Torque Setting Chart on next page for tightening details.*

#### Every 4 Weeks

- Grease Roller Bearings (4 off) - this should be done slowly using 1 shot of grease only to avoid blowing out the seals.
- Grease Roller Adjuster Slides - 1 each side, inside of cover.
- Remove plastic plug at top of adjuster screws and run oil around adjuster threads, replace plugs.

# TORQUE SETTINGS FOR FASTENERS

The Chart below lists the correct tightening torque for fasteners. The Chart should be referred to when tightening or replacing bolts in order to determine the grade of bolt and the correct torque except where specific torque values are assigned in the text of this manual.

*Recommended torque is quoted in Foot-Pounds and Newton-Metres within this manual. The equation for conversion is 1 Nm. = 1.356 ft. lbs.*

## TORQUE VALUES FOR IMPERIAL BOLTS

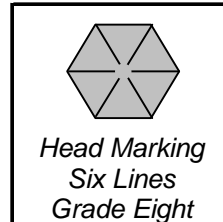
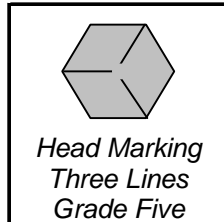
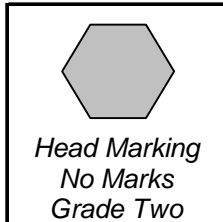

**NOTE:**  
*The values in the chart apply to fasteners as received from the supplier, dry or when lubricated with normal engine oil. They DO NOT apply if special graphited, molydisulphide greases, or other extreme pressure lubricants are used. This applies to both UNF and UNC coarse threads.*

Bolt Dia.
1/4"
5/16"
3/8"
7/16"
1/2"
9/16"
5/8"
3/4"
7/8"
1"
1-1/8"
1-1/4"
1-3/8"
1-1/2"

Value (Dry)	
ft.lb.	Nm.
5.5	7.5
11	15.0
20	27.0
32	43.0
50	68.0
70	95.0
100	135.0
175	240.0
175	240.0
270	360.0
375	510.0
530	720.0
700	950.0
930	1250.0

Value (Dry)	
ft.lb.	Nm.
9	12.2
18	25.0
33	45.0
52	70.0
80	110.0
115	155.0
160	220.0
280	380.0
450	610.0
675	915.0
850	115.0
1200	1626.0
1550	2100.0
2100	2850.0

Value (Dry)	
ft.lb.	Nm.
12.5	17.0
26	35.2
46	63.0
75	100.0
115	155.0
160	220.0
225	305.0
400	540.0
650	880.0
975	1325.0
1350	1830.0
1950	2650.0
2550	3460.0
3350	4550.0

## TORQUE VALUES FOR METRIC BOLTS.

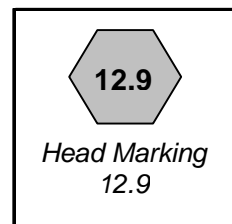
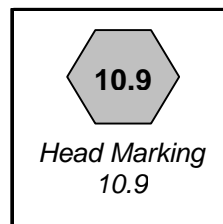
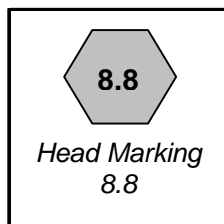
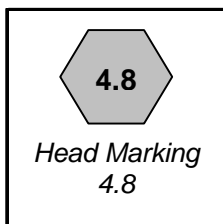

Bolt Dia.
6mm
8mm
10mm
12mm
14mm
16mm
18mm
20mm
22mm
24mm
27mm
30mm

Value (Dry)	
ft.lb.	Nm.
4.5	6.1
11	14.9
21	28.5
37	50.2
60	81.4
92	125.0
125	170.0
180	245.0
250	340.0
310	420.0
450	610.0
625	850.0

Value (Dry)	
ft.lb.	Nm.
8.5	11.5
20	27.1
40	54.2
70	95.0
110	150.0
175	240.0
250	340.0
350	475.0
475	645.0
600	810.0
875	1180.0
1200	1626.0

Value (Dry)	
ft.lb.	Nm.
12	16.3
30	40.1
60	81.4
105	140.0
165	225.0
255	350.0
350	475.0
500	675.0
675	915.0
850	1150.0
1250	1700.0
1700	2300.0

Value (Dry)	
ft.lb.	Nm.
14.5	20.0
35	47.5
70	95.0
120	160.0
190	260.0
300	400.0
410	550.0
580	790.0
800	1090.0
1000	1350.0
1500	2000.0
2000	2700.0

# TRM6 & TRM8 Roller Mowers

## Parts Manual

**TRM6 MAIN ASSEMBLIES**

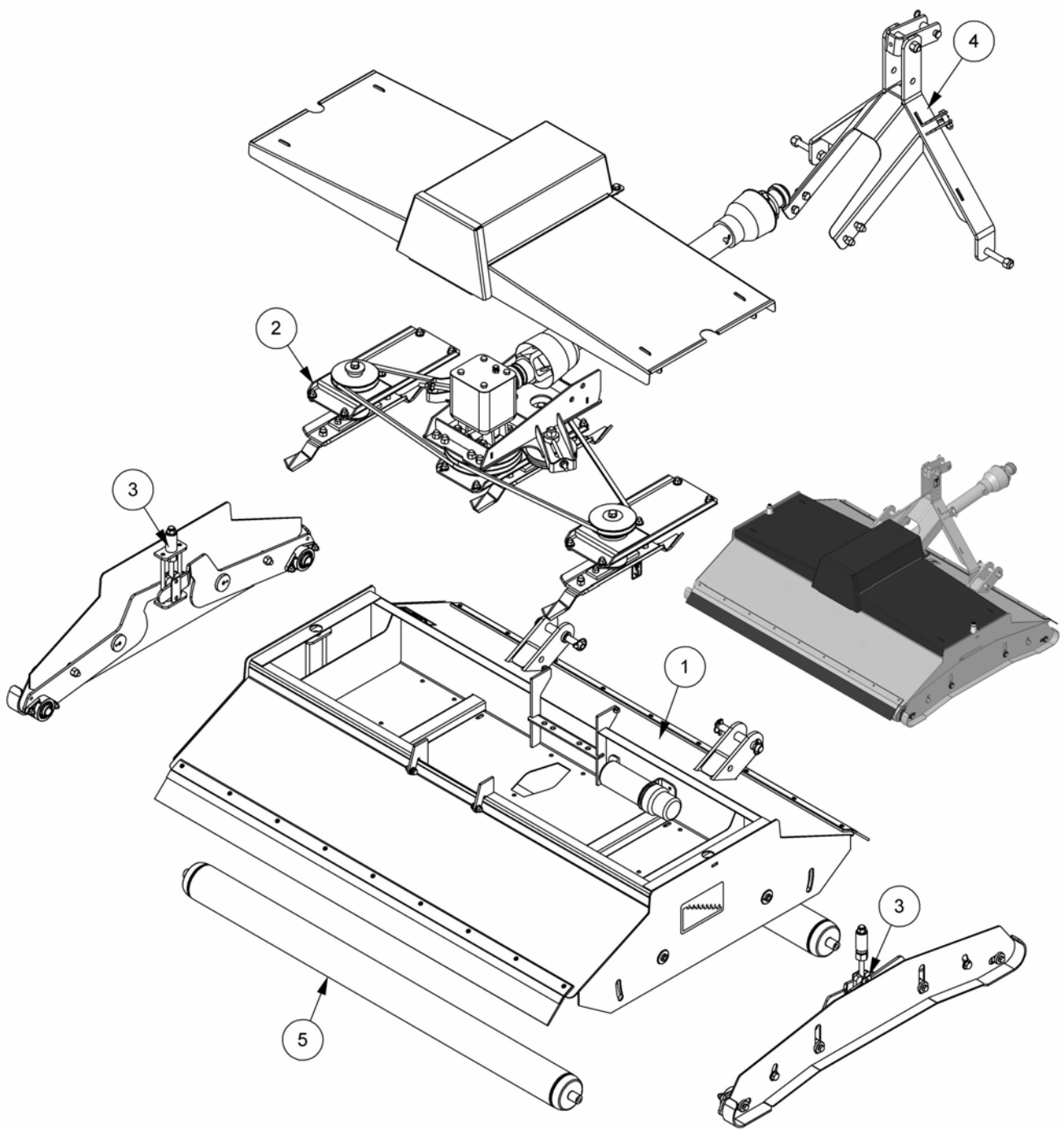

REF.	QTY.	PART No.	DESCRIPTION
		<b>1057904</b>	<b>TRM6 REAR MOUNT ROLLER MOWER</b>
1	1	1057700	TRM6 DECK MODULE
2	1	1057702	TRM6 DRIVE MODULE
3	2	1057706	TRM6/TRM8 SIDE SKID & ADJUSTER MODULE
4	1	1057707	TRM6/TRM8 A-FRAME MODULE
5	2	21019.01	TRM6 ROLLER ASSEMBLY



**TRM8 MAIN ASSEMBLIES**

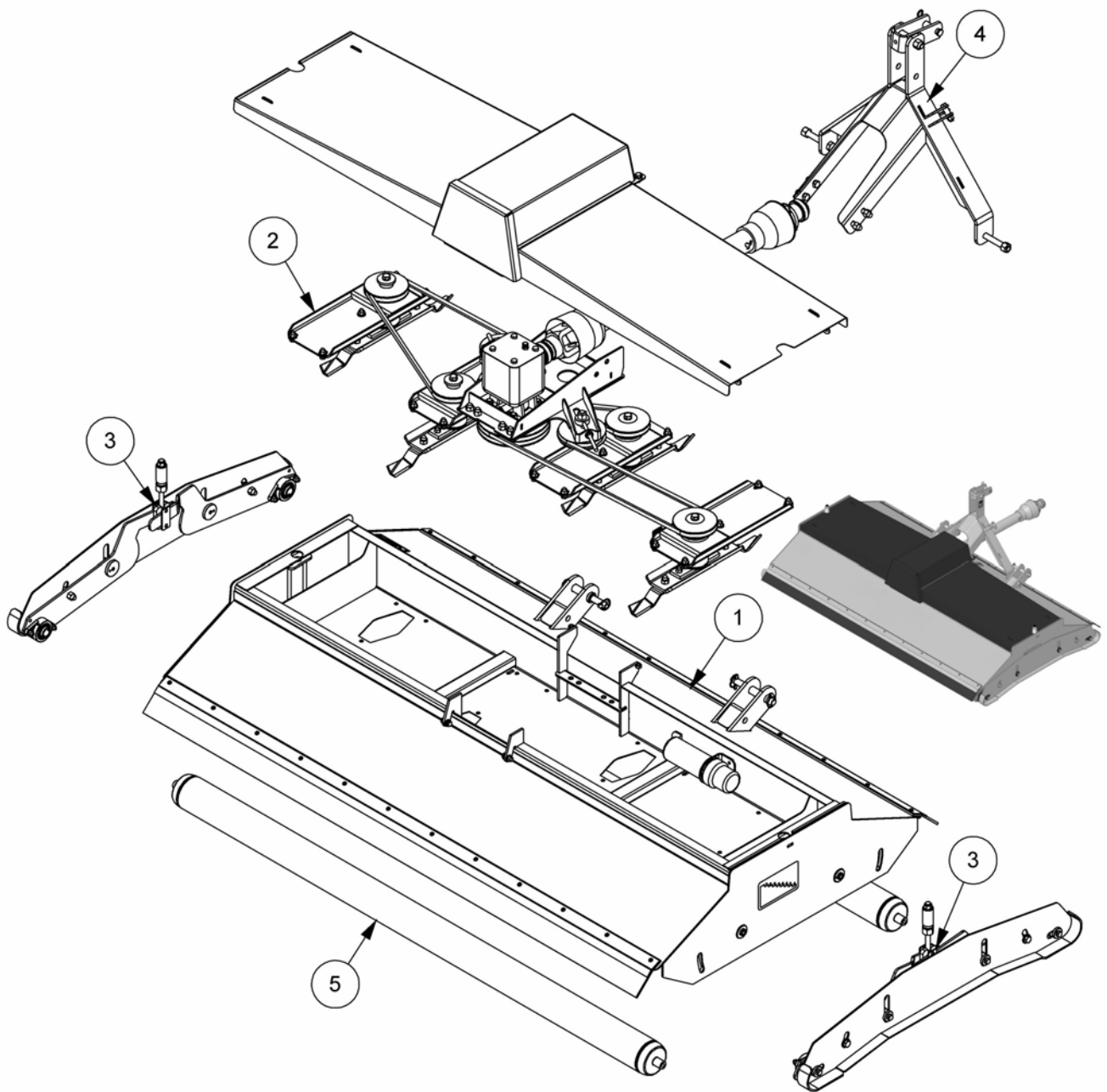

REF.	QTY.	PART No.	DESCRIPTION
		<b>1057911</b>	<b>TRM8 REAR MOUNT ROLLER MOWER</b>
1	1	1057701	TRM8 DECK MODULE
2	1	1057703	TRM8 DRIVE MODULE
3	2	1057706	TRM6/TRM8 SIDE SKID & ADJUSTER MODULE
4	1	1057707	TRM6/TRM8 A-FRAME MODULE
5	2	21019.02	TRM8 ROLLER ASSEMBLY

# TRM6 DECK ASSEMBLY

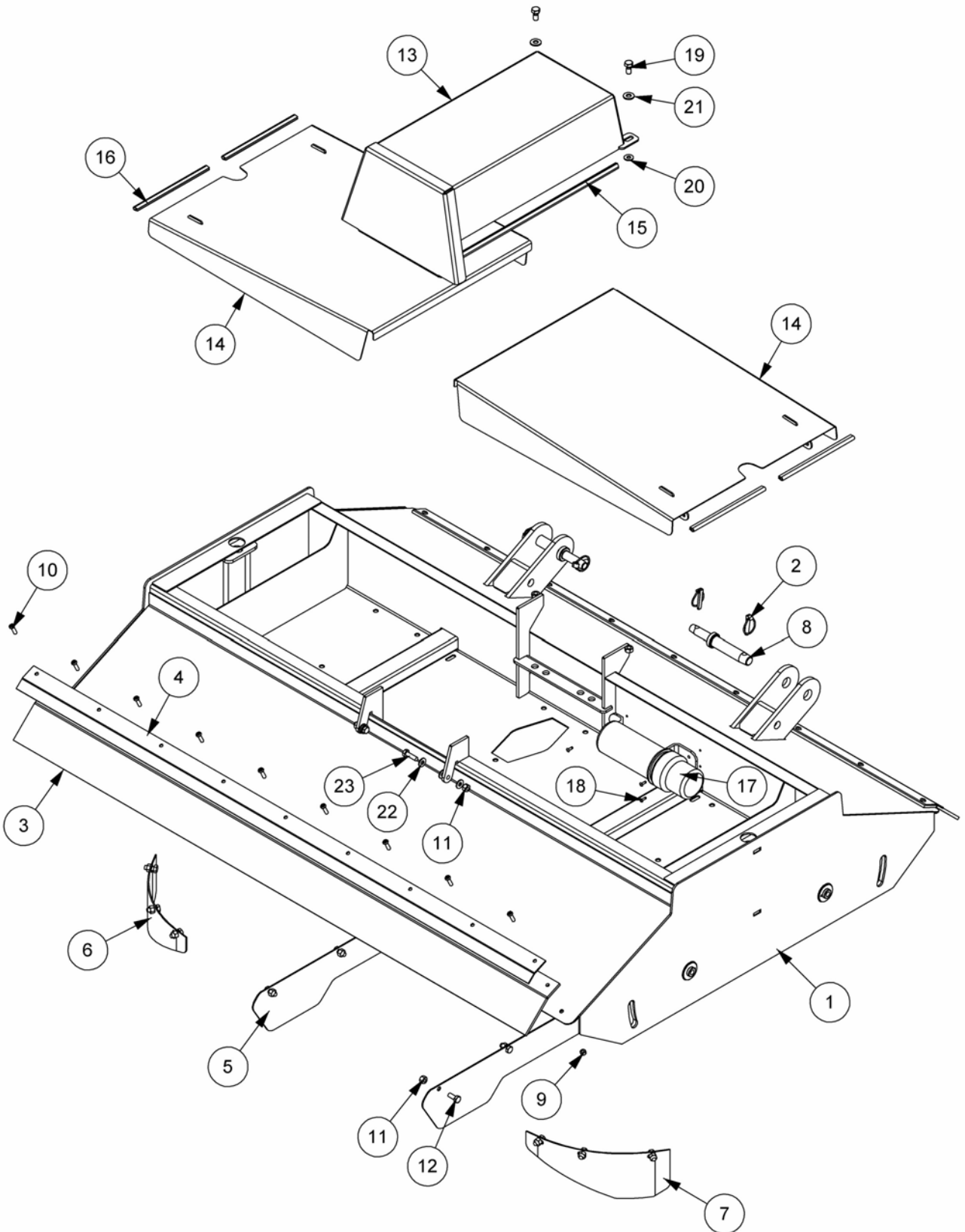

**TRM6 DECK ASSEMBLY**

REF.	QTY.	PART No.	DESCRIPTION
		<b>1057700</b>	<b>TRM6 DECK ASSEMBLY</b>
1	1	21003.06	DECK - TRM6
2	4	0431217	LINCH PIN
3	2	21038.01	RUBBER SKIRT
4	2	21038.02	SKIRT PLATE
5	2	21037.01	BAFFLE PLATE
6	1	21003.72	BAFFLE - L/H
7	1	21003.73	BAFFLE - R/H
8	2	21158.01	LOWER LINK PIN
9	18	9143004	SELF-LOCKING NUT
10	18	9300151	BUTTON HEAD CAP SCREW
11	18	9143005	SELF-LOCKING NUT
12	16	9313055	SETSCREW
13	1	21016.05	GEARBOX COVER
14	2	21016.07	DRIVE COVER - TRM6
15	2	41741.18	EDGING STRIP (570mm)
16	4	41741.17	EDGING STRIP (260mm)
17	1	46505.01	LITERATURE HOLDER
18	3	21612.01	POP RIVET
19	2	21044.01	CAPTIVE SCREW
20	2	21044.02	CAPTIVE WASHER
21	2	9100106	FLAT WASHER
22	6	9100105	FLAT WASHER
23	2	9313075	SETSCREW

# TRM8 DECK ASSEMBLY

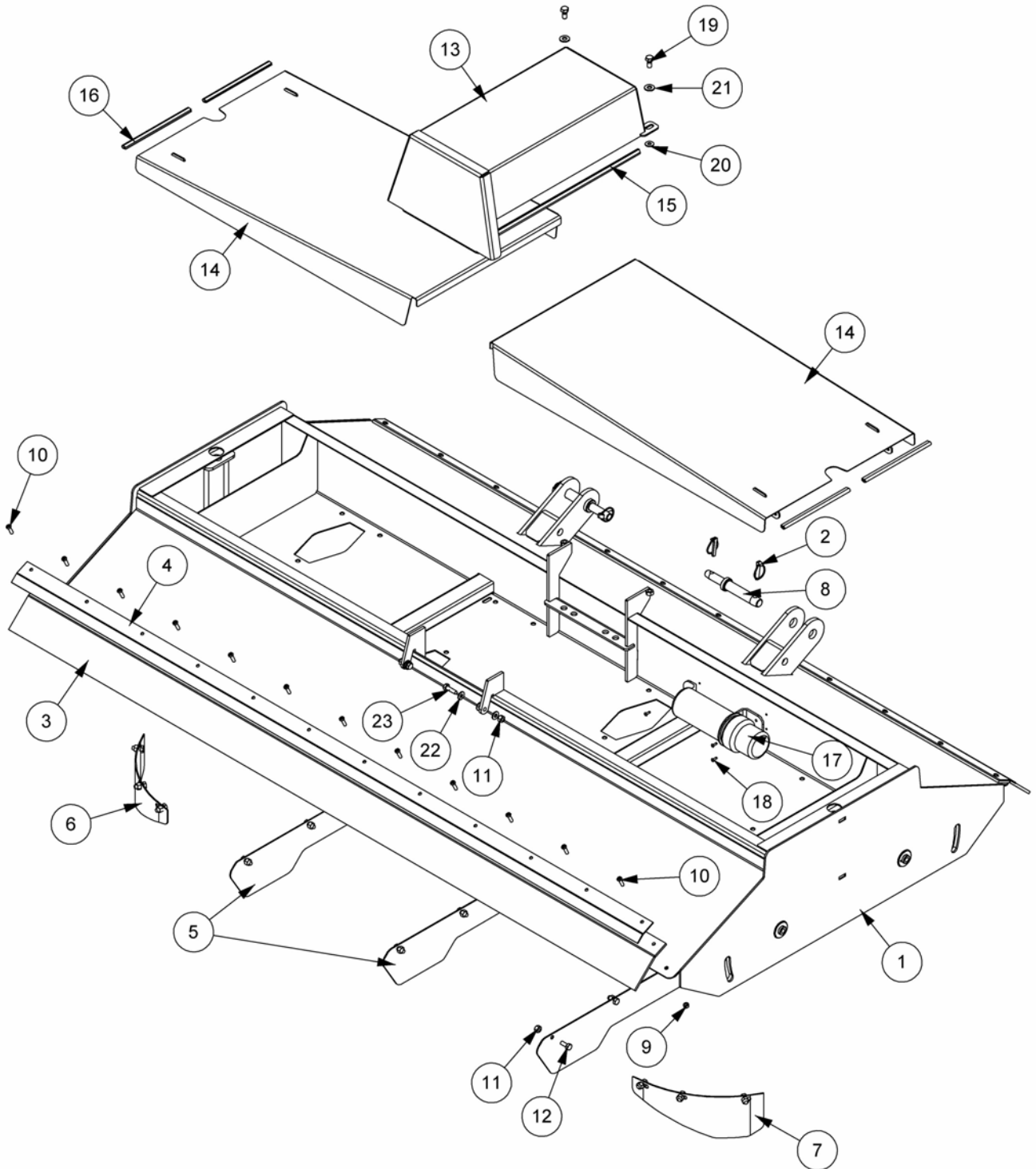

**TRM8 DECK ASSEMBLY**

REF.	QTY.	PART No.	DESCRIPTION
		<b>1057701</b>	<b>TRM8 DECK ASSEMBLY</b>
1	1	21003.05	DECK - TRM8
2	4	0431217	LINCH PIN
3	2	21038.03	RUBBER SKIRT
4	2	21038.04	SKIRT PLATE
5	3	21037.01	BAFFLE PLATE
6	1	21003.72	BAFFLE - L/H
7	1	21003.73	BAFFLE - R/H
8	2	21158.01	LOWER LINK PIN
9	24	9143004	SELF-LOCKING NUT
10	24	9300151	BUTTON HEAD CAP SCREW
11	23	9143005	SELF-LOCKING NUT
12	21	9313055	SETSCREW
13	1	21016.05	GEARBOX COVER
14	2	21016.06	DRIVE COVER - TRM8
15	2	41741.18	EDGING STRIP (570mm)
16	4	41741.17	EDGING STRIP (260mm)
17	1	46505.01	LITERATURE HOLDER
18	3	21612.01	POP RIVET
19	2	21044.01	CAPTIVE SCREW
20	2	21044.02	CAPTIVE WASHER
21	2	9100106	FLAT WASHER
22	6	9100105	FLAT WASHER
23	2	9313075	SETSCREW

**TRM6 DRIVE ASSEMBLY**

*NOTE: One belt runs in the upper groove of pulley's #4 & #17 the other belt in the lower grooves - spacers #9 are placed above or below respective pulley's #5 as shown to align the belt runs.*

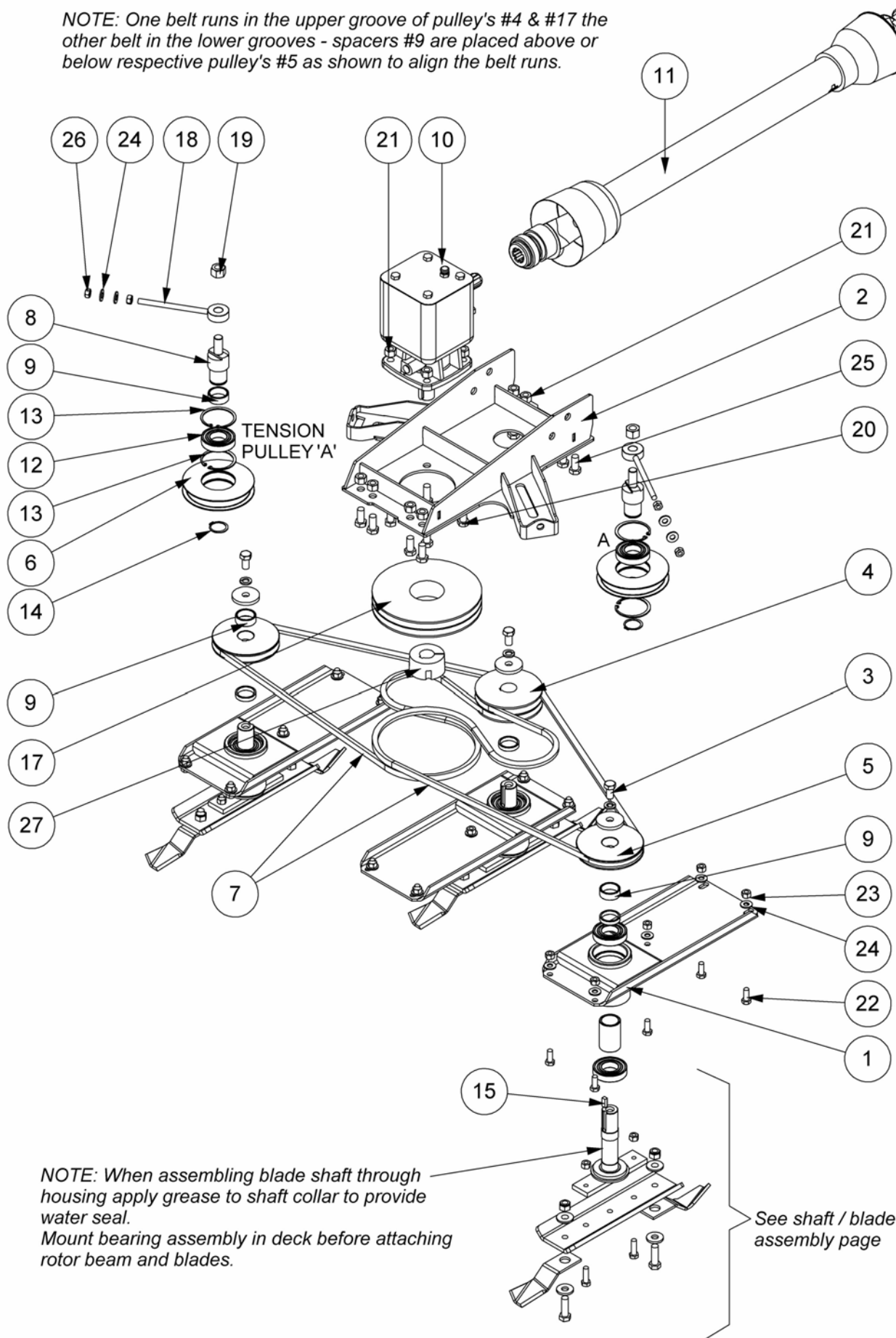

*NOTE: When assembling blade shaft through housing apply grease to shaft collar to provide water seal.  
Mount bearing assembly in deck before attaching rotor beam and blades.*



**TRM6 DRIVE ASSEMBLY**

REF.	QTY.	PART No.	DESCRIPTION
		<b>1057702</b>	<b>TRM6 DRIVE ASSEMBLY</b>
1	3	21024.01	BEARING FABRICATION
2	1	21017.04	GEARBOX MOUNTING PLATE
3	3	21025.21	SHAFT BLADE ASSEMBLY
4	1	21028.02	DRIVEN PULLEY
5	2	21028.03	DRIVEN PULLEY
6	2	21028.04	TENSION PULLEY
7	2	21032.01	WEDGE BELT
8	2	21029.31	TENSIONER SHAFT
9	4	21028.31	SPACER TUBE
10	1	21030.01	GEARBOX
11	1	21040.01	PTO SHAFT
12	2	0600014	BALL BEARING
13	4	0411280	INTERNAL CIRCLIP
14	2	0401240	EXTERNAL CIRCLIP
15	2	21025.37	KEY
16	1	21025.33	KEY
17	1	21028.01	2-BELT PULLEY
18	2	21025.03	TENSION ADJUSTER
19	2	9143008	SELF-LOCKING NUT
20	4	9313087	SETSCREW
21	12	9143007	SELF-LOCKING NUT
22	15	9313066	SETSCREW
23	15	9143006	SELF-LOCKING NUT
24	19	9100106	FLAT WASHER
25	8	9313077	SETSCREW
26	4	9113006	NUT
27	1	05.424.23	TAPER LOCK BUSH

**TRM8 DRIVE ASSEMBLY**

*NOTE: One belt runs in the upper groove of pulley's #6 & #7 the other belt in the lower grooves - spacers #11 are placed above or below respective pulley's #5 as shown to align the belt runs.*

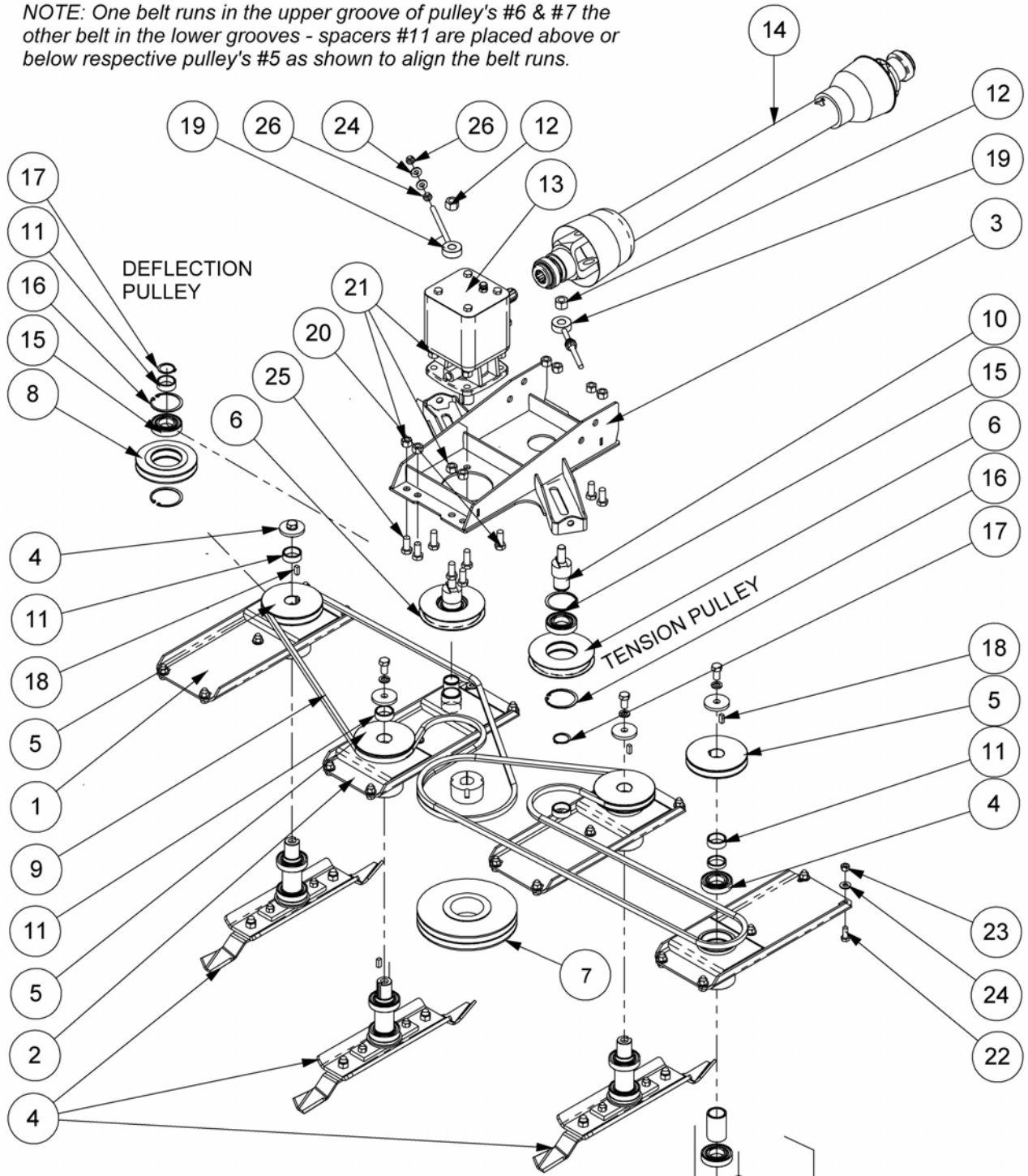

*NOTE: When assembling blade shaft through housing apply grease to shaft collar to provide water seal.  
Mount bearing assembly in deck before attaching rotor beam and blades.*

*See shaft / blade assembly page*



**TRM8 DRIVE ASSEMBLY**

REF.	QTY.	PART No.	DESCRIPTION
		<b>1057703</b>	<b>TRM8 DRIVE ASSEMBLY</b>
1	3	21024.01	BEARING FABRICATION
2	1	21024.02	BEARING FABRICATION
3	1	21017.03	GEARBOX MOUNTING PLATE
4	4	21025.21	SHAFT BLADE ASSEMBLY
5	4	21028.03	DRIVEN PULLEY
6	2	21028.04	TENSION PULLEY
7	1	21028.01	2-BELT PULLEY
8	1	21028.06	DEFLECTION PULLEY
9	2	21032.02	WEDGE BELT
10	2	21029.31	TENSIONER SHAFT
11	7	21028.31	SPACER TUBE
12	2	9143008	SELF-LOCKING NUT
13	1	21030.01	GEARBOX
14	1	21040.01	PTO SHAFT
15	3	0600014	BALL BEARING
16	6	0411280	INTERNAL CIRCLIP
17	3	0401240	EXTERNAL CIRCLIP
18	4	21025.37	KEY
19	2	21025.03	TENSION ADJUSTER
20	4	9313087	SETSCREW
21	12	9143007	SELF-LOCKING NUT
22	20	9313066	SETSCREW
23	20	9143006	SELF-LOCKING NUT
24	24	9100106	FLAT WASHER
25	8	9313077	SETSCREW
26	4	9113006	NUT
27	1	05.424.23	TAPER LOCK BUSH

**BLADE & SHAFT ASSEMBLY – TRM6 & TRM8**

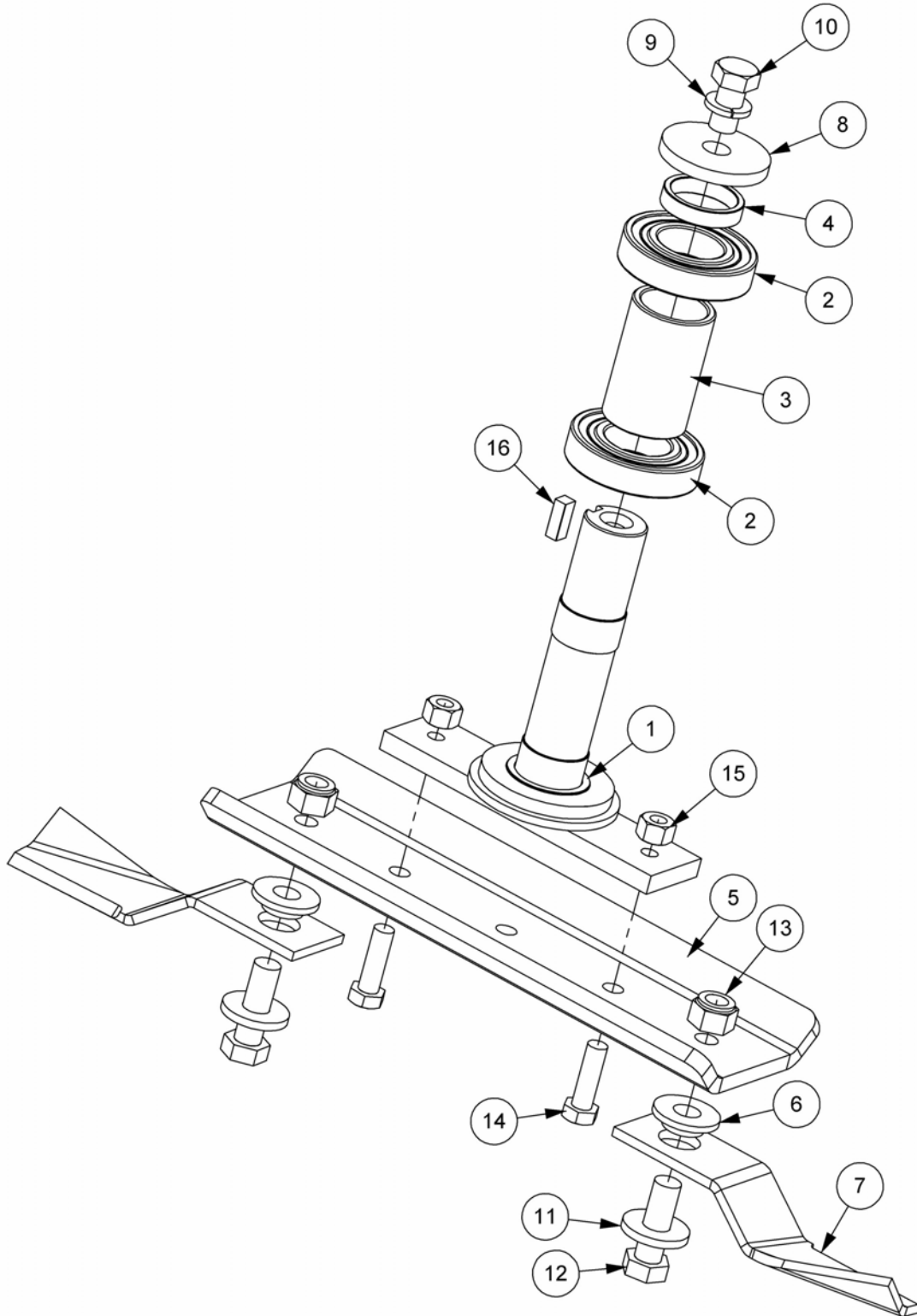

**BLADE & SHAFT ASSEMBLY – TRM6 & TRM8**

<b>REF.</b>	<b>QTY.</b>	<b>PART No.</b>	<b>DESCRIPTION</b>
		<b>21025.21</b>	<b>BLADE &amp; SHAFT ASSEMBLY</b>
1	1	21025.01	ROTOR SHAFT
2	2	0600014	BALL BEARING
3	1	06.782.01	BEARING SPACER
4	1	21025.34	PULLEY SPACER
5	1	21025.32	ROTOR BEAM
6	2	06.237.02	COLLAR
7	2	06.208.02	BLADE (CCW)
8	1	04.252.01	WASHER
9	1	9100207	SPRING WASHER
10	1	9313067	SETSCREW
11	2	06.236.01	WASHER
12	2	05.839.06	BOLT
13	2	05.948.17	NUT
14	2	9313086	SETSCREW
15	2	9143006	SELF-LOCKING NUT
16	1	21025.37	KEY

**A-FRAME ASSEMBLY – TRM6 & TRM8**

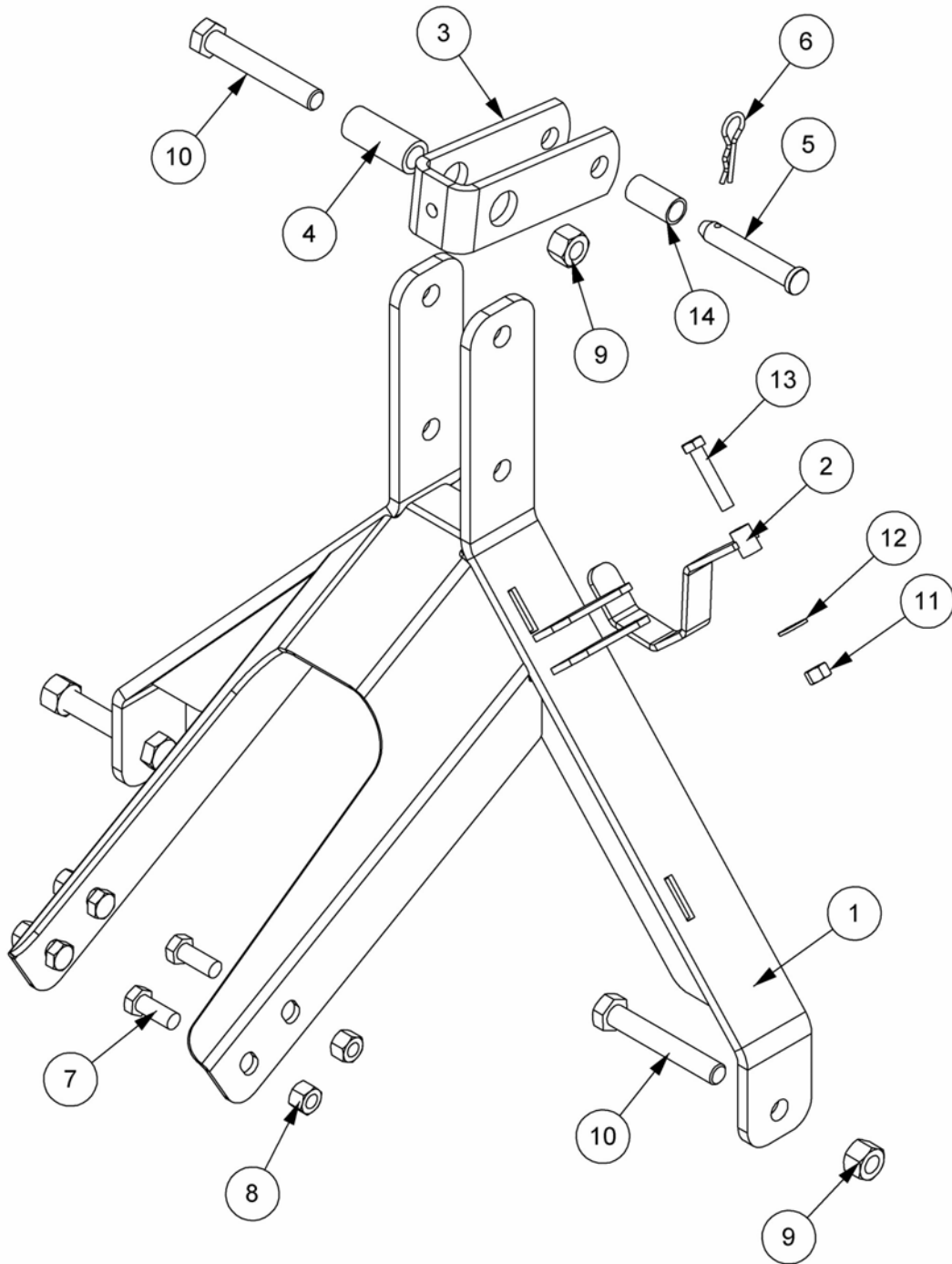

**A-FRAME ASSEMBLY – TRM6 & TRM8**

<b>REF.</b>	<b>QTY.</b>	<b>PART No.</b>	<b>DESCRIPTION</b>
		<b>1057707</b>	<b>A-FRAME ASSEMBLY</b>
1	1	22593.01	A-FRAME
2	1	21159.02	PTO SUPPORT
3	1	00766540	TOP LINK
4	1	00766542	BUSHING
5	1	37107B12	PIN - TOP LINK
6	1	0431105	SPRING COTTER
7	4	9313087	SETSCREW
8	4	9143007	SELF-LOCKING NUT
9	3	9143008	SELF-LOCKING NUT
10	3	9213268	BOLT
11	1	9143006	SELF-LOCKING NUT
12	1	9100106	FLAT WASHER
13	1	9313126	SETSCREW
14	1	1467063	SLEEVE (CAT.1 TO CAT.2)

**SIDE SKID ASSEMBLY – TRM6 & TRM8**

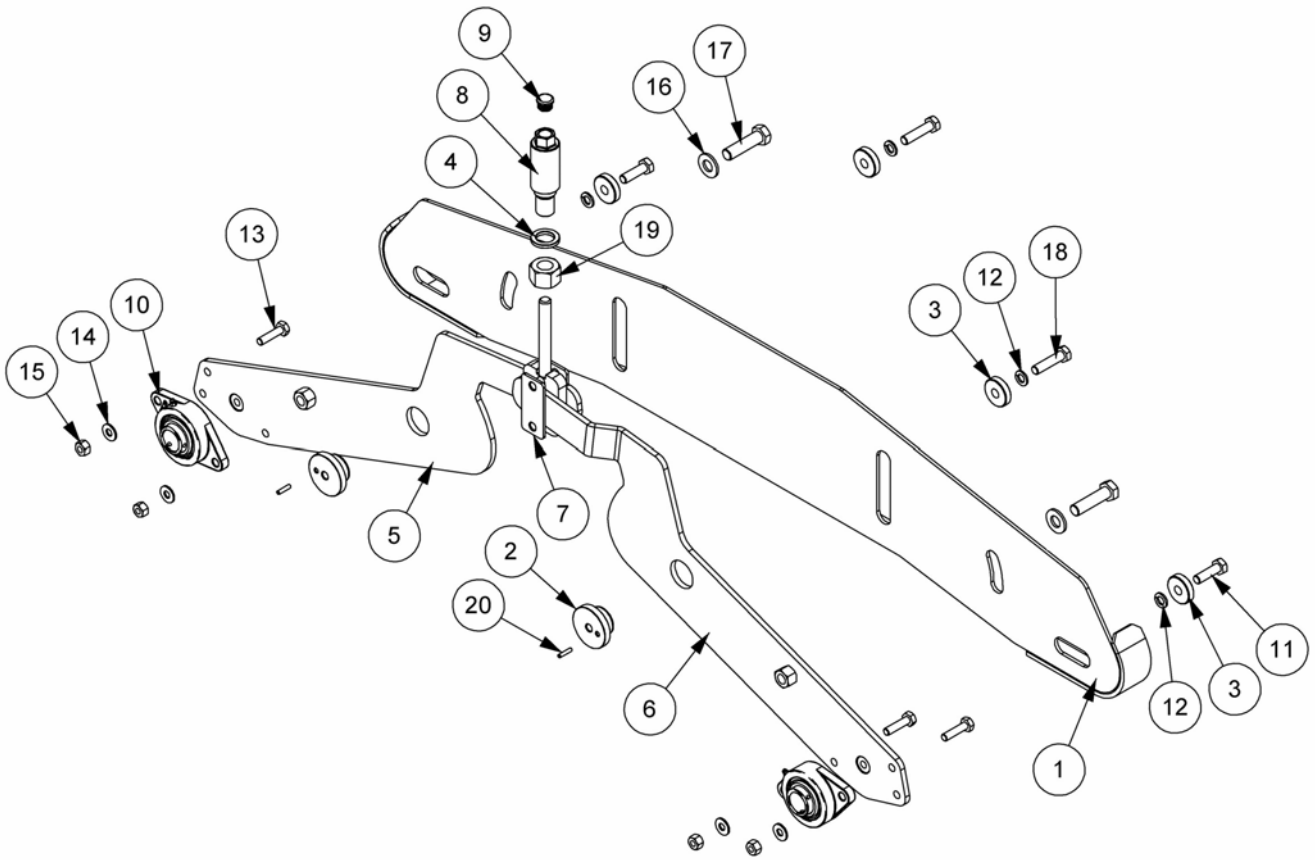

**SIDE SKID ASSEMBLY – TRM6 & TRM8**

REF.	QTY.	PART No.	DESCRIPTION
		<b>1057706</b>	<b>SIDE SKID ASSEMBLY</b>
1	1	21018.01	SIDESKID ASSEMBLY
2	2	21020.10	TAPPED BOSS
3	4	21020.12	WASHER PLATE
4	1	21020.15	THRUST WASHER
5	1	21020.16	STRAIGHT ROLLER SIDE PLATE
6	1	21020.17	OFFSET ROLLER SIDE PLATE
7	1	21020.18	ADJUSTABLE SLIDE
8	1	21020.50	SHORT ADJUSTMENT NUT
9	1	43358.02	PLASTIC BUNG
10	2	46092.01	FLANGE BEARING UNIT
11	2	9213086	BOLT
12	4	9100206	SPRING WASHER
13	4	9213085	BOLT
14	4	9100105	FLAT WASHER
15	4	9143005	SELF-LOCKING NUT
16	2	0100106	WASHER
17	2	9213127	BOLT
18	2	9213106	BOLT
19	1	9143009	SELF-LOCKING NUT
20	2	0425522	SPRING DOWEL

**DECALS**

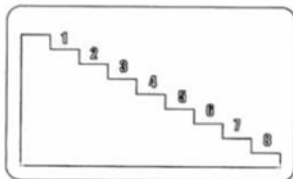
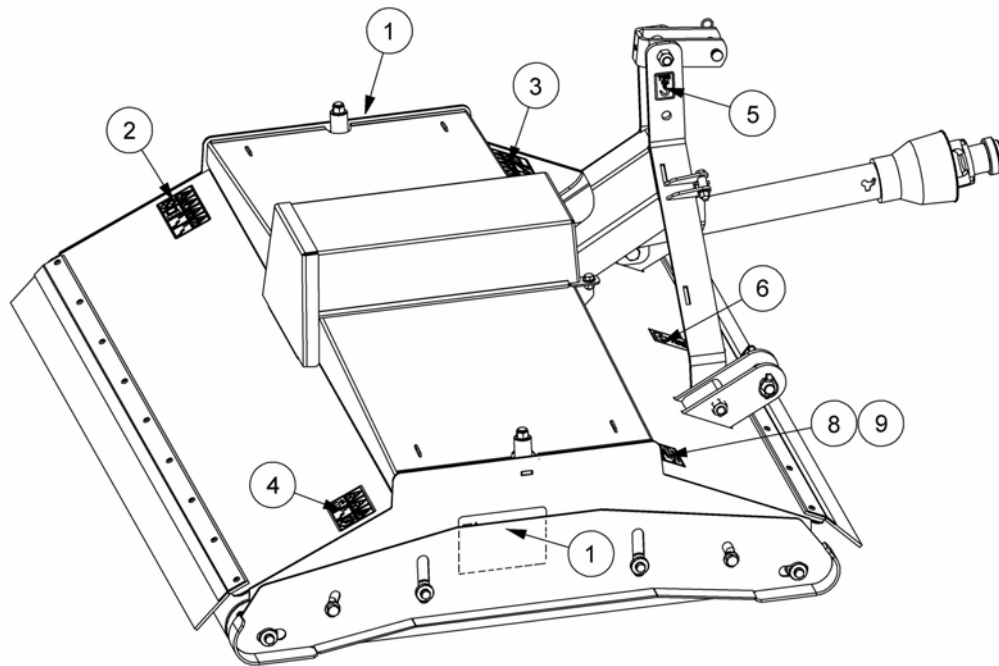

21048.31



09.821.29



09.821.34



09.821.30



1290527



09.811.04 (540RPM)  
09.811.02 (1000RPM)

REF.	QTY.	PART No.	DESCRIPTION
1	2	21048.31	DECAL - CUTTING HEIGHT
2	1	09.821.29	COMBINED EURODECAL
3	1	09.821.34	COMBINED EURODECAL
4	1	09.821.30	EURODECAL ROTARY
5	1	09.843.04	DECAL - 750 Kg
6	1	09.811.04	DECAL - 540 MAX ACW
	1	09.811.02	DECAL - 1000 MAX ACW
7	1	45429.03	SERIAL No. PLATE
8	4	7103230	POP RIVET



