

TWOSE
TORNADO EURO
& EURO OPEN
Models 230/250/280
Operation & Parts Manual

Machines 04/16 ►

Publication 540

(April 2016)

IMPORTANT VERIFICATION OF WARRANTY REGISTRATION



DEALER WARRANTY INFORMATION & REGISTRATION VERIFICATION

It is imperative that the selling dealer registers this machine with Twose of Tiverton Limited before delivery to the end user – failure to do so may affect the validity of the machine warranty.

To register machines go to the Twose web site at www.twose.com, log onto 'Dealer Inside' and select the 'Machine Registration button' which can be found in the Service Section of the site. Confirm to the customer that the machine has been registered in the section below.

Should you experience any problems registering a machine in this manner please contact the Twose Office on 01884 253691.

Registration Verification

Dealer Name:
Dealer Address:
Customer Name:
Date of Warranty Registration:/...../..... Dealer Signature:

NOTE TO CUSTOMER / OWNER

Please ensure that the above section above has been completed and signed by the selling dealer to verify that your machine has been registered with Twose of Tiverton Limited.

IMPORTANT: During the initial 'bedding in' period of a new machine it is the customer's responsibility to regularly inspect all nuts, bolts and hose connections for tightness and re-tighten if required. New hydraulic connections occasionally weep small amounts of oil as the seals and joints settle in – where this occurs it can be cured by re-tightening the connection – *refer to torque settings chart below*. The tasks stated above should be performed on an hourly basis during the first day of work and at least daily thereafter as part of the machines general maintenance procedure.

TORQUE SETTINGS FOR HYDRAULIC FITTINGS

HYDRAULIC HOSE ENDS		
BSP	Setting	Metric
1/4"	18 Nm	19 mm
3/8"	31 Nm	22 mm
1/2"	49 Nm	27 mm
5/8"	60 Nm	30 mm
3/4"	80 Nm	32 mm
1"	125 Nm	41 mm
1.1/4"	190 Nm	50 mm
1.1/2"	250 Nm	55 mm
2"	420 Nm	70 mm

PORT ADAPTORS WITH BONDED SEALS		
BSP	Setting	Metric
1/4"	34 Nm	19 mm
3/8"	47 Nm	22 mm
1/2"	102 Nm	27 mm
5/8"	122 Nm	30 mm
3/4"	149 Nm	32 mm
1"	203 Nm	41 mm
1.1/4"	305 Nm	50 mm
1.1/2"	305 Nm	55 mm
2"	400 Nm	70 mm

WARRANTY POLICY

WARRANTY REGISTRATION

All machines must be registered, by the selling dealer with Twose of Tiverton Ltd, before delivery to the end user. On receipt of the goods it is the buyer's responsibility to check that the Verification of Warranty Registration in the Operator's Manual has been completed by the selling dealer.

1. LIMITED WARRANTIES

- 1.01. *All machines supplied by Twose of Tiverton Ltd are warranted to be free from defects in material and workmanship from the date of sale to the original purchaser for a period of 12 months, unless a different period is specified.*
- 1.02. *All spare parts supplied by Twose of Tiverton Ltd and purchased by the end user are warranted to be free from defects in material and workmanship from the date of sale to the original purchaser for a period of 6 months. All parts warranty claims must be supported by a copy of the failed part invoice to the end user. We cannot consider claims for which sales invoices are not available.*
- 1.03. *The warranty offered by Twose of Tiverton Ltd is limited to the making good by repair or replacement for the purchaser any part or parts found, upon examination at its factory, to be defective under normal use and service due to defects in material or workmanship. Returned parts must be complete and unexamined. Pack the component(s) carefully so that any transit damage is avoided. All ports on hydraulic items should be drained of oil and securely plugged to prevent seepage and foreign body ingress. Certain other components, electrical items for example, may require particular care when packing to avoid damage in transit.*
- 1.04. *This warranty does not extend to any product from which Twose of Tiverton Ltd's serial number plate has been removed or altered.*
- 1.05. *This warranty does not apply to any part of the goods, which has been subjected to improper or abnormal use, negligence, alteration, modification, fitment of non-genuine parts, accident damage, or damage resulting from contact with overhead power lines, damage caused by foreign objects (e.g. stones, iron, material other than vegetation), failure due to lack of maintenance, use of incorrect oil or lubricants, contamination of the oil, or which has served its normal life. This warranty does not apply to any expendable items such as blades, belts, clutch linings, filter elements, flails, flap kits, skids, soil engaging parts, shields, guards, wear pads, pneumatic tyres or tracks.*
- 1.06. *Temporary repairs and consequential loss - i.e. oil, downtime and associated parts are specifically excluded from the warranty.*
- 1.07. *Warranty on hoses is limited to 12 months and does not include hoses which have suffered external damage. Only complete hoses may be returned under warranty, any which have been cut or repaired will be rejected.*
- 1.08. *Machines must be repaired immediately a problem arises. Continued use of the machine after a problem has occurred can result in further component failures, for which Twose of Tiverton Ltd cannot be held liable, and may have safety implications.*
- 1.09. *If in exceptional circumstances a non Twose of Tiverton Ltd part is used to effect a repair, warranty reimbursement will be at no more than Twose of Tiverton Ltd's standard dealer cost for the genuine part.*
- 1.10. *Except as provided herein, no employee, agent, dealer or other person is authorised to give any warranties of any nature on behalf of Twose of Tiverton Ltd.*
- 1.11. *For machine warranty periods in excess of 12 months the following additional exclusions shall apply:*
 - 1.11.1. *Hoses, exposed pipes and hydraulic tank breathers.*
 - 1.11.2. *Filters.*
 - 1.11.3. *Rubber mountings.*
 - 1.11.4. *External electric wiring.*
 - 1.11.5. *Bearings and seals.*

- 1.12. All service work, particularly filter changes, must be carried out in accordance with the manufacturer's service schedule. Failure to comply will invalidate the warranty. In the event of a claim, proof of the service work being carried out may be required.
- 1.13. Repeat or additional repairs resulting from incorrect diagnosis or poor quality previous repair work are excluded from warranty.

NB Warranty cover will be invalid if any non-genuine parts have been fitted or used. Use of non-genuine parts may seriously affect the machine's performance and safety. Twose of Tiverton Ltd cannot be held responsible for any failures or safety implications that arise due to the use of non-genuine parts.

2. REMEDIES AND PROCEDURES

- 2.01. The warranty is not effective unless the Selling Dealer registers the machine, via the Twose of Tiverton Ltd web site and confirms the registration to the purchaser by completing the confirmation form in the operator's manual.
- 2.02. Any fault must be reported to an authorised Twose of Tiverton Ltd dealer as soon as it occurs. Continued use of a machine, after a fault has occurred, can result in further component failure for which Twose of Tiverton Ltd cannot be held liable.
- 2.03. Repairs should be undertaken within two days of the failure. Claims submitted for repairs undertaken more than 2 weeks after a failure has occurred, or 2 days after the parts were supplied will be rejected, unless the delay has been authorised by Twose of Tiverton Ltd. Please note that failure by the customer to release the machine for repair will not be accepted as a reason for delay in repair or submitting warranty claims.
- 2.04. All claims must be submitted, by an authorised Twose of Tiverton Ltd Service Dealer, within 30 days of the date of repair.
- 2.05. Following examination of the claim and parts, Twose of Tiverton Ltd will pay, at their discretion, for any valid claim the invoiced cost of any parts supplied by Twose of Tiverton Ltd and appropriate labour and mileage allowances if applicable.
- 2.06. The submission of a claim is not a guarantee of payment.
- 2.07. Any decision reached by Twose of Tiverton Ltd is final.

3. LIMITATION OF LIABILITY

- 3.01. Twose of Tiverton Ltd disclaims any express (except as set forth herein) and implied warranties with respect to the goods including, but not limited to, merchantability and fitness for a particular purpose.
- 3.02. Twose of Tiverton Ltd makes no warranty as to the design, capability, capacity or suitability for use of the goods.
- 3.03. Except as provided herein, Twose of Tiverton Ltd shall have no liability or responsibility to the purchaser or any other person or entity with respect to any liability, loss, or damage caused or alleged to be caused directly or indirectly by the goods including, but not limited to, any indirect, special, consequential, or incidental damages resulting from the use or operation of the goods or any breach of this warranty. Notwithstanding the above limitations and warranties, the manufacturer's liability hereunder for damages incurred by the purchaser or others shall not exceed the price of the goods.
- 3.04. No action arising out of any claimed breach of this warranty or transactions under this warranty may be brought more than one (1) year after the cause of the action has occurred.

4. MISCELLANEOUS

- 4.01. Twose of Tiverton Ltd may waive compliance with any of the terms of this limited warranty, but no waiver of any terms shall be deemed to be a waiver of any other term.
- 4.02. If any provision of this limited warranty shall violate any applicable law and is held to be unenforceable, then the invalidity of such provision shall not invalidate any other provisions herein.
- 4.03. Applicable law may provide rights and benefits to the purchaser in addition to those provided herein.



DECLARATION OF CONFORMITY

Conforming to EU Machinery Directive 2006/42/EC

We,

TWOSE of TIVERTON LIMITED,
6 Chinon Court, Lower Moor Way,
Tiverton Business Park, Tiverton, Devon, EX16 6SS, UK

Hereby declare that:

The Product; *Tractor Mounted Flail Mower*

Product Code; *T23E, T25E, T28E*

Serial No. & Date Type

Manufactured in; *Slovenija*

Complies with the required provisions of the Machinery Directive 2006/42/EC
The machinery directive is supported by the following harmonized standards;

- BS EN ISO 12100 (2010) Safety of machinery – General principles for design – Risk assessment and risk reduction.
- BS EN 349 (1993) + A1 (2008) Safety of machinery - Minimum distances to avoid the entrapment with human body parts.
- BS EN 953 (1997) + A1 (2009) Safety of machinery - Guards general requirements for the design and construction of fixed and movable guards.
- BS EN 4413 (2010) Hydraulic fluid power. Safety requirements for systems and their components.

Signed  *Responsible Person*
CHRISTIAN DAVIES on behalf of TWOSE OF TIVERTON LIMITED

Status: *General Manager*

Date: *September 2015*

LIST OF CONTENTS

OPERATOR SECTION

General Information	1
Machine Description & Purpose of Use	2
Machine Identification	2
Technical Data	2
Technical Specifications	3
Safety Information	4
Safety Decals	5
Vehicle / Tractor Preparation	6
Machine Attachment	7
PTO Shaft	8
Pre-Operational Checks	8
Setting Up and Adjustment	9
Drive Belts	10
Operation	11
Detachment and Storage	12
Maintenance	13
Troubleshooting	15

PARTS SECTION

Tornado Euro Assembly	17
Tornado Euro Open Assembly	23
Support Wheels	31

GENERAL INFORMATION

Always read this manual before fitting or operating the machine – whenever any doubt exists contact your dealer or the Twose Service Department for advice and assistance.

Use only Twose Genuine Service Parts on Twose Equipment and Machines

DEFINITIONS – The following definitions apply throughout this manual:

WARNING

An operating procedure, technique etc., which –
can result in personal injury or loss of life if not observed carefully.

CAUTION

An operating procedure, technique etc., which –
can result in damage to either machine or equipment if not observed carefully.

NOTE

An operating procedure, technique etc., which –
is considered essential to emphasis.

LEFT AND RIGHT HAND

This term is applicable to the machine when attached to the tractor and is viewed
from the rear – this also applies to tractor references.

MACHINE & DEALER INFORMATION

Record the Serial Number of your machine on this page and always quote this number when ordering parts. Whenever information concerning the machine is requested remember also to state the make and model of tractor to which the machine is fitted.

Machine Serial Number:

Installation Date:

Machine Model details:

Dealer Name:

Dealer Address:

Dealer Telephone No:

Dealer Email Address:

MACHINE DESCRIPTION & PURPOSE OF USE

The Tornado Euro series of machines are '3- point linkage' tractor mounted universal flail mower/shredders designed primarily for the mulching of grasses, brambles, small bushes, branches, vines, and general crop residues. Their tough construction, working widths of 2.3, 2.5 or 2.8m and offset capability of up to 0.5m makes them ideal for maintenance use in all green areas, vineyards, orchards, on verges and in scrubland by farmers and contractors alike. Open models feature an opening rear cover that allows for quicker discharge of materials when working in denser vegetation.

These machines should only be used to perform tasks for which they were designed – use of the machine for any other function may be both dangerous to persons and damaging to components and is therefore not advisable.

MACHINE IDENTIFICATION

Each machine is fitted with an identification plate with the following information:

1. Machine (Part Number)
2. Machine Serial No.
3. Machine Weight

When ordering spares or replacement parts from your local dealer it is important to quote both Part Number and Serial Number as stated on the identification plate so the machine and model can be quickly and correctly identified.

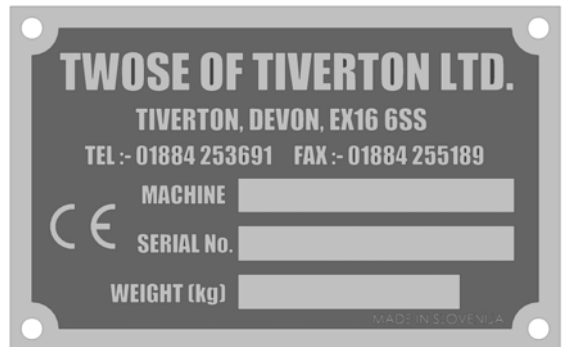

Machine Identification Plate

TECHNICAL DATA

COMPONENT IDENTIFICATION

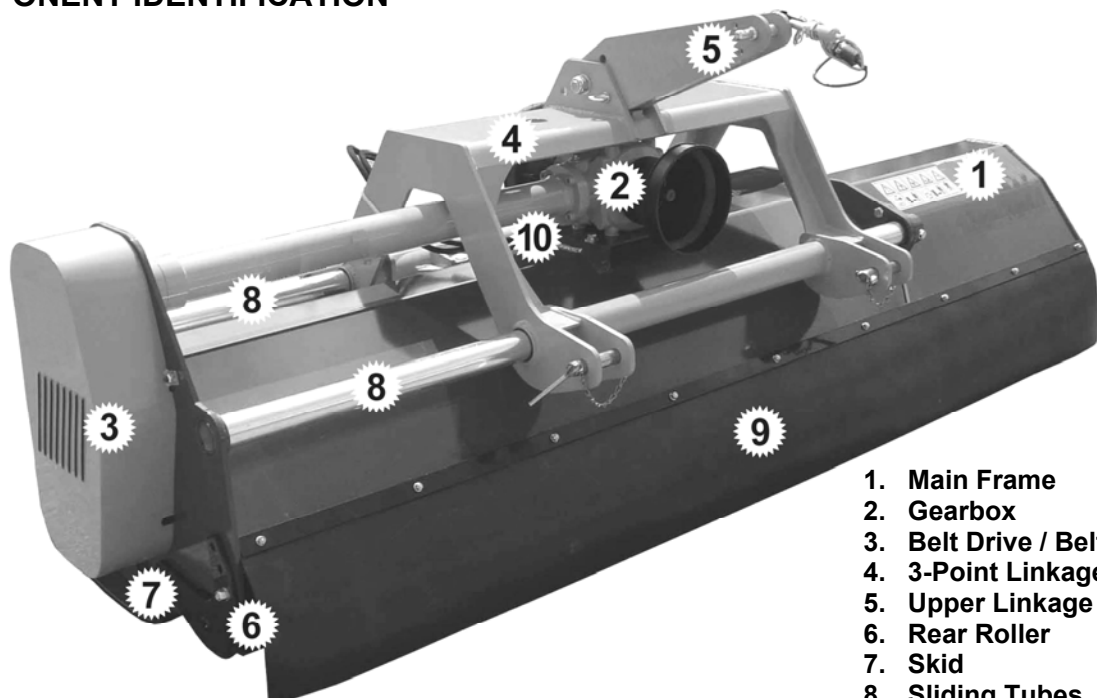

1. Main Frame
2. Gearbox
3. Belt Drive / Belt Guard
4. 3-Point Linkage
5. Upper Linkage
6. Rear Roller
7. Skid
8. Sliding Tubes
9. Rubber Guard
10. Hydraulic Ram

TECHNICAL SPECIFICATIONS

Euro Models

SPECIFICATION	230	250	280
Working Width	2280mm	2440mm	2770mm
Tractor Power Requirement	55-60 HP	65-75 HP	75-85 HP
PTO RPM	1000 RPM	1000 RPM	1000 RPM
Rotor Shaft RPM	2243 RPM	2243 RPM	2243 RPM
Hammer Blades	26	28	32
Y-Blades	78	84	96
Machine Weight	750kg	785kg	850kg
Offset Capability	500mm	500mm	500mm
Linkage Type	3-Point (Cat. II)	3-Point (Cat. II)	3-Point (Cat. II)
Machine Width	2510mm	2670mm	3000mm
Machine Length	1010mm	1010mm	1010mm
Machine Height	1050mm	1050mm	1050mm

Euro Open Models

SPECIFICATION	230	250	280
Working Width	2280mm	2440mm	2770mm
Tractor Power Requirement	55-60 HP	65-75 HP	75-85 HP
PTO RPM	1000 RPM	1000 RPM	1000 RPM
Rotor Shaft RPM	2243 RPM	2243 RPM	2243 RPM
Hammer Blades	26	28	32
Y-Blades	78	84	96
Machine Weight	780kg	815kg	865kg
Offset Capability	500mm	500mm	500mm
Linkage Type	3-Point (Cat. II)	3-Point (Cat. II)	3-Point (Cat. II)
Machine Width	2510mm	2670mm	3000mm
Machine Length	1010mm	1010mm	1010mm
Machine Height	1050mm	1050mm	1050mm

OPTIONAL EQUIPMENT

The standard flails fitted to the machine are the hammer blade type; Y-blade flails are optional. The cutting capability of the each particular type of flail will be dependant on the sort and hardness of the material being cut, but in general the following cutting thicknesses apply:

Y-blade flails – for materials up to a maximum of 30mm diameter.

Hammer flails – for materials up to a maximum of 50mm diameter.

NOISE LEVEL

The sound level of this machine, as measured at the operator's ear, is within the range of 70 to 90 dB when the rear window of the tractor is open. We recommend that ear protectors are worn and the tractor windows kept closed at all times when operating this machine.

SAFETY INFORMATION

General safety rules:

- ▲ Always read and follow the instructions for the use and maintenance of the machine before carrying out any work operations or servicing tasks.
- ▲ Improper use of the machine is both highly dangerous to persons and damaging to the machine components – only use the machine for its designated task.
- ▲ Both operators and the maintenance fitters should be familiar with the machine and fully aware of dangers surrounding improper use or incorrect repairs.
- ▲ Before starting, checks to both tractor and machine must be carried out as regards: functionality, road safety, accident prevention rules.
- ▲ Even when using the machine correctly, stones or other objects may be thrown a long distance. Therefore nobody must stand within the danger area. Special attention must be paid when working near roads or buildings.
- ▲ Use tractor's fitted with safety cabs.
- ▲ The condition of flails and of machine guards must be checked before beginning the daily work - they must be replaced if damaged or missing before you use the machine.
- ▲ During checks or repairs, make sure nobody could start the machine by mistake.
- ▲ Never wear loose or fluttering clothes.
- ▲ Never carry passengers on the tractor.
- ▲ Never carry passengers on the machine.
- ▲ Never connect the power takeoff with the engine running.
- ▲ Never approach the machine until the rotor has completely stopped.
- ▲ Do not enter the working zone of the PTO shaft. It is dangerous to approach the rotating parts of a machine.
- ▲ Keep the PTO shaft guard in good condition.
- ▲ Before starting, check the surrounding area for the likely presence of children and/or animals.
- ▲ Do not stand near the machine when it is operating.
- ▲ The PTO shaft must be assembled and disassembled only with the engine stopped and the starting key removed.
- ▲ Before connecting the power takeoff, check that the speed and the rotational direction correspond to those of the machine.
- ▲ Immediately replace missing or damaged safety decals.
- ▲ Before leaving the tractor with the machine attached, proceed as follows:
 1. Disconnect the power takeoff,
 2. Put the machine steadily on the ground using the tractor's hydraulic lift.
 3. Apply the hand brake and, if the ground is steeply sloping, wedge the tractor.
 4. Remove the starting key.

Transportation Safety

- ▲ In transport, reduce speed, especially on bumpy roads, the weight of the machine may render driving difficult and damage the machine itself.
- ▲ Ensure the levers that operate the hydraulic lift are locked, to avoid the lowering of the machine during transport.
- ▲ When driving on public roads, respect all road rules in force.
- ▲ Never transport the machine with the rotor running, even for short distances.

Operating Safety

- ▲ Pay special attention when working with the machine not to touch fixed objects such as road drain, walls, shafts, kerbs, guard rails, tracks etc. This could cause the breakage of the flails, which would be thrown out of the machine at very high speed.
- ▲ If wires, ropes or chains should become entangled in the rotor stop immediately to prevent damage or dangerous situations; stop the rotor and the tractor, take out the starting key. Put working gloves on; clear the rotor with the aid of pliers or shears. Do not try to disentangle by inverting the rotational direction of the rotor.
- ▲ Do not use the machine when excessive vibration is experienced, as this may cause breakage and serious damage - find the cause of the vibration and eliminate it before using the machine again.

Although the information given here covers a wide range of safety subjects, it is impossible to predict every eventuality that can occur under differing circumstances whilst operating this machine. No advice given here can replace 'good common sense' and 'total awareness' at all times, but will go a long way towards the safe use of your Twose machine.

SAFETY DECALS

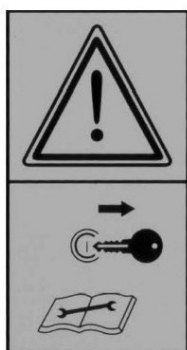

1.

1. Always switch machine off, remove starting key and read instruction manual before performing service or maintenance work on the machine.



2.

2. Keep a safe distance from the machine at all times - risk from projection of objects.



3.

3. Risk of hand injury – always ensure all guards are fitted and in place when machine is operating.



4.

4. Risk of feet injury – keep at a safe distance from the machine when it is operating.



5.

5. Never stand or ride on the machine.

VEHICLE / TRACTOR PREPARATION

We recommend vehicles are fitted with cabs using 'safety glass' windows and protective guarding when used with our machines.

Fit Operator Guard (part no. 7313324) using the hooks provided. Shape the mesh to cover all vulnerable areas.

Remember the driver must be looking through mesh and/or polycarbonate

glazing when viewing the machine in all positions - unless the vehicle/ cab manufacturer can demonstrate that the penetration resistance is equivalent to, or higher than, that provided by mesh/polycarbonate glazing. If the tractor has a roll bar only, a frame must be made to carry both mesh and polycarbonate glazing. The operator should also use personal protective equipment to reduce the risk of serious injury such as; eye protection (mesh visor to EN1731 or safety glasses to EN166), hearing protection to EN352, safety helmet to EN297, gloves, filter mask and high visibility clothing.

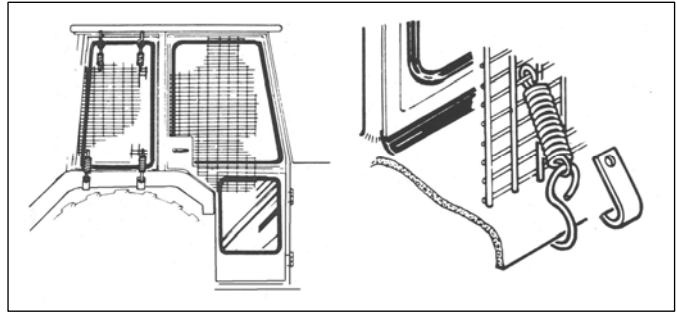

Vehicle Ballast

It is imperative when attaching 'third-party' equipment to a vehicle that the maximum possible stability of the machine and vehicle combination is achieved – this can be accomplished by the utilisation of 'ballast' in order to counter-balance the additional equipment added.

Front weights may be required for rear mounted machines to place 15% of total outfit weight on the front axle for stable transport on the road and to reduce 'crabbing' due to the drag of the cutting unit when working on the ground.

Where a machine works to the side of the tractor rear weights may be required to maintain a reasonable amount of rear axle load on the opposing wheel.

All factors must be addressed in order to match the type and nature of the equipment added to the circumstances under which it will be used - factors that effect stability are:

- Centre of gravity of the tractor/machine combination.
- Geometric conditions, e.g. position of the cutting head and ballast.
- Weight, track width and wheelbase of the tractor.
- Acceleration, braking, turning and the relative position of the cutting unit during these operations.
- Ground conditions, e.g. slope, grip, load capability of the soil/surface.
- Rigidity of implement mounting.

Suggestions to increase stability:

- Increasing rear wheel track - *a vehicle with a wider wheel track is more stable.*
- Ballasting the wheel; it is preferable to use external weights but liquid can be added to around 75% of the tyre volume – water with anti-freeze or the heavier Calcium Chloride alternative can be used.
- Addition of weights – care should be taken in selecting the location of the weights to ensure they are added to a position that offers the greatest advantage.
- Front axle locking, check with tractor manufacturer.

The advice above is offered as a guide for stability only and is not a guide to vehicle strength. It is therefore recommended that you consult your vehicle manufacturer or local dealer to obtain specific advice on this subject, additionally advice should be sought from a tyre specialist with regard to tyre pressures and ratings suitable for the type and nature of the machine you intend to fit.

ATTACHING THE MACHINE TO THE TRACTOR

Attachment of the machine to the tractor should always be performed on a firm level site.

Upper Linkage Position

The upper linkage of the machine has two working modes to allow the machine to be mounted and operated either on the front of the tractor or on the rear:

1. Front Mounted Linkage Position
2. Rear Mounted Linkage Position

To swap the linkage position, remove the position locking pin and swing the linkage over to the opposing side of the machine, replace the position locking pin and secure in place with a locking clip.

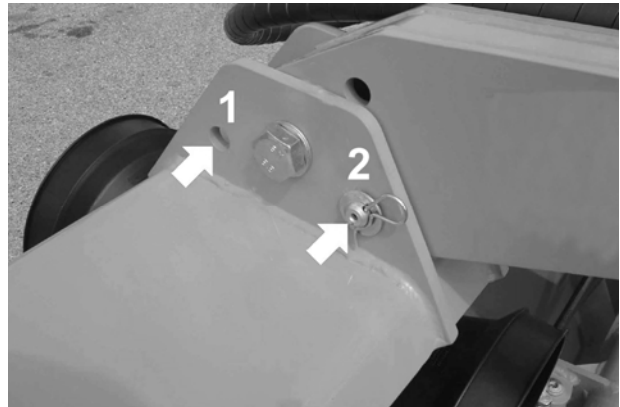

NOTE: The position locking pin must always be in position during attachment and transportation of the machine but can be removed during work for a floating position. Always remember to replace the pin before re-transporting the machine.

Linkage Points

- A – Lower Attachment Points (Linkage Arms)
- B – Upper Attachment Point (Top Link)

Attachment to Tractor

Determine if the machine is to be front mounted or rear mounted and set the upper linkage into the required position as described above.

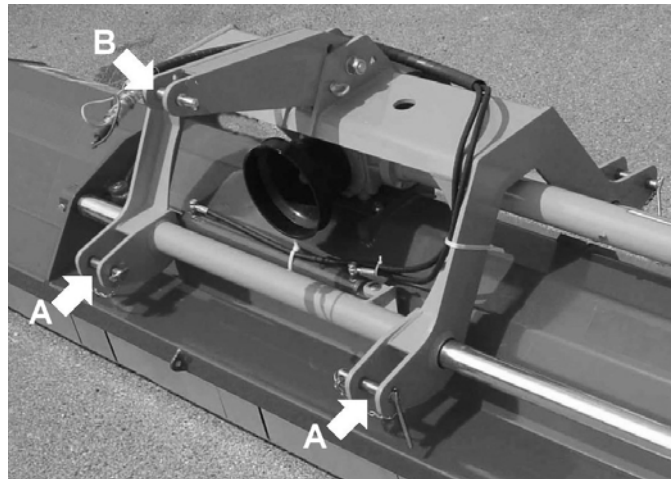

Position the tractor's lower linkage at the same height as the machine's lower attachment points – indicated 'A' in the diagram above.

Remove the machine lower linkage pins from location 'A'.

Carefully manoeuvre the tractor squarely to the machine and into its position within the attachment points – fine adjustment of the tractor lower linkage height may be necessary to correctly position the linkage and permit refitting of the linkage pins.

Insert linkage pins at location 'A' and secure in position with locking clips.

Fit top link to upper attachment point 'B'.

Raise the machine on the tractor's hydraulics and adjust top link so that the machine is parallel to the ground.

Fit and adjust check chains and/or stabiliser bars to lock the machine into a central position on the tractor.

Connect hydraulics.

Fit PTO Shaft and attach torque chains to a suitable location – refer to following page for details of PTO measurement and shaft length adjustment.

PTO Shaft Measurement

Measure the PTO shaft and cut to the dimension shown – the finished length of the PTO shaft should be 75mm (3") less than the measured distance 'A' - between tractor shaft and gearbox stub shaft - to enable fitting.

NOTE:

For subsequent use with different tractors measure again, there must be a minimum shaft overlap of 150mm (6").

Fit PTO in position and attach the torque chains to a convenient location to prevent the shaft guards from rotating.

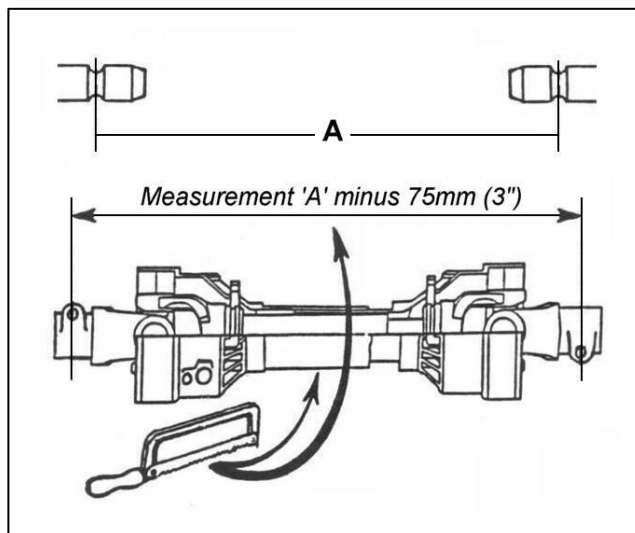

PTO Shaft Length Adjustment

1. Shorten outer plastic tube to 40mm less than the shortest envisaged shaft length.
2. Remove the marked tube.
3. Remove same length from inner plastic tube and metal shaft profiles (inner and outer).
4. De-burr all edges and remove 'swarf' to ensure smooth operation.

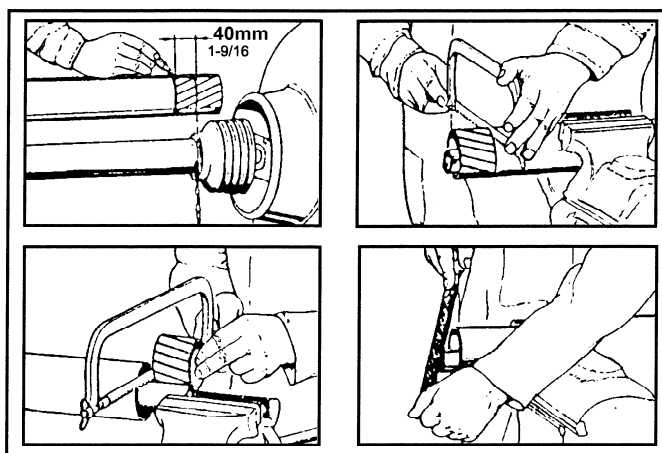

Pre-Operational Checks

Before commencing work with the machine the following checks should be performed:

- Make a visual inspection of the machine to ensure it is in good operational condition.
- Check all safety guarding is in position and in full working order.
- Check rotor for missing or damaged flails and replace if required.
- Check all greasing points are well lubricated.
- Check gearbox oil level.
- Check belt tension and adjust if required.
- Check PTO speed and direction match that of the machine.

SETTING UP AND ADJUSTMENT

The height of cut is dependent on working conditions and volume of material. The cutting height can be regulated with the hydraulic system on the tractor and/or rear roller adjustment. The minimum height of cut should be between 1 – 3cm.

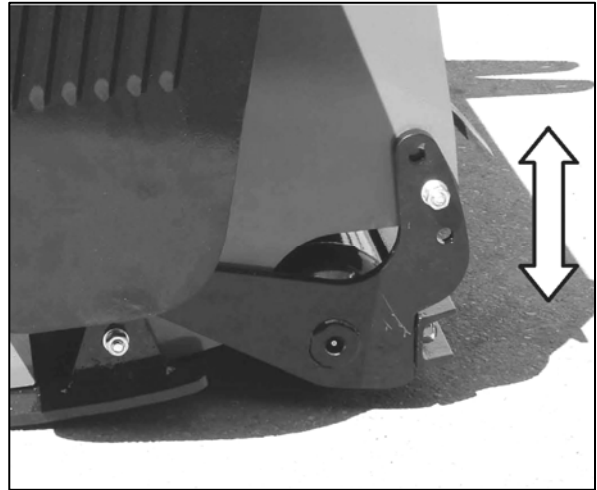

NOTE: The machine must always run on the rear roller not the side skids – side skids are a protection feature and in normal working conditions remain clear of the ground. Do not allow the rotor flails to contact the ground - set roller height to allow a minimum flail to ground clearance of 1 to 3cm.

Offsetting

The machine features a hydraulically operated offsetting capability of up to 500mm allowing the machine to cut larger areas of material beyond the wheel tracks of the tractor – this is particularly useful for verge mowing duties and work in areas of limited or restricted accessibility. The machine offsets to the right hand side of the tractor.

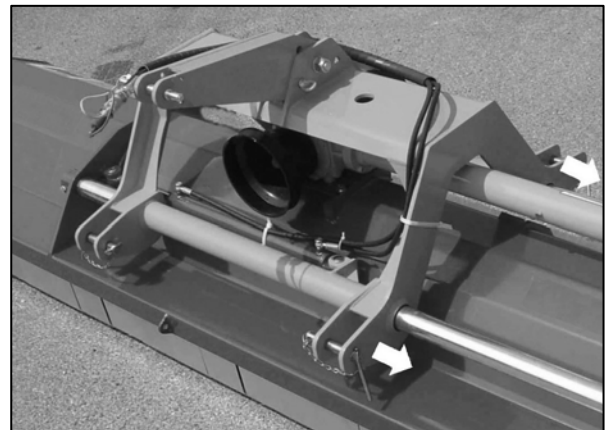

Hydraulically operated offset of up to 500mm

DRIVE BELTS

Power from the tractor via the machine's gearbox and half-shaft is transferred to the rotor through sets of belts - *the Euro 230 models employ a 4 belt system and Euro 250 & 280 models employ a 5 belt system.* Correct tensioning of the belts is required for both optimal operation of the machine and long lasting belt life – in order to ensure correct belt tension the machines are fitted with automatic belt tensioning.

Check tightness of the taper lock bolts on a regular basis, the torque setting is 45Nm.

Belt Tensioner

Machines are fitted as standard with an automatic belt tensioning system. The system consists of a pre-tensioned arm and strain pulley set at 22° that permanently runs on the belts exerting sufficient pressure to keep the belts correctly tensioned.

For correct tension the system must be set at an angle of 22° – an arrow is marked on the tension device to aid its setting, which should always be performed when the belts are cold.

No other adjustment or maintenance will be required on the belt tensioning system other than routine inspection and general cleaning of components when inspecting belt wear.

WARNING: Checking of belts and drive components should only be carried out with tractor's engine switched off, starting key removed and the PTO shaft disconnected. Never attempt to run the machine with the belt guard removed.

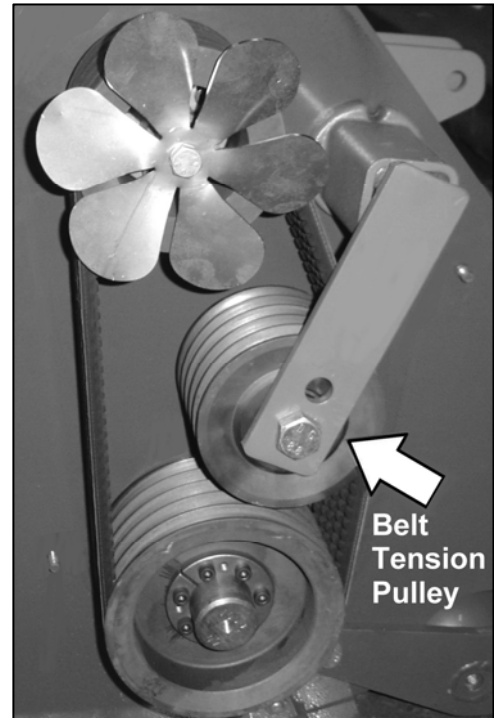

Belt Tensioner ►

Machine RPM

These machines are all 1000 RPM - before operating the machine always ensure the RPM is compatible with the tractor PTO speed – this is particularly important on tractors that have different PTO speeds front and rear.

WARNING: Always check machine and tractor PTO speeds are compatible before using the machine.

Flail Types

Two types of flails are available for use with these machines, these are shown below;

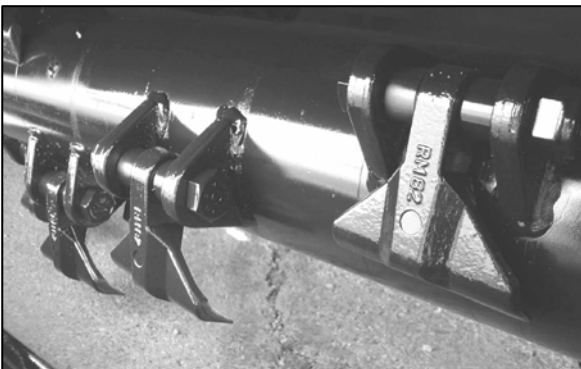

Hammer Flails

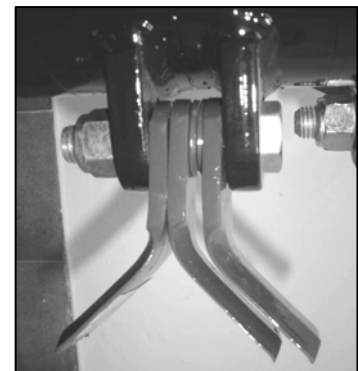

Y-Flails

OPERATION

Ensure that the operator is suitably qualified to use a machine of this nature and that they have fully read and understood this manual - they should be aware of all safety aspects relating to the safe use of the machine. It is advisable that all 'first time' operators practice using the machine in a clear safe area prior to work in order to familiarise themselves with its operation.

After the initial first 2 hours of work with a new machine, nuts and bolts should be checked for tightness and the drive belts inspected and re-tensioned if required – refer to belt section for details.

Prior to starting work the area should be checked for dangerous objects such as large stones, wood, wire, glass etc. – hazardous objects should be removed from the area prior to operation with the machine. The location of unmovable or natural hazards should be noted, or if necessary 'marked', to indicate to the operator that the area should either be avoided or additional caution adopted whilst working around the hazard.

Starting Work

With the machine switched off, lower it into a position approximately 10cm above the ground, start the machine and allow it to build up to the correct working speed before gently lowering the it onto the ground - the machine is now in its work position and forward travel can begin.

Forward Speed

The forward working speed will depend on the working conditions and nature of the material being cut. Optimal speed will be in the region of 3-8 km/h (2-5 mph).



Optimal forward working speed 3-8 km/h



Raise the machine before turning or reversing

Reversing & Turning

When reversing or turning the unit the machine must always be lifted clear of the ground to avoid damage.

Transport

The following must be observed at all times when transporting the machine:

- Machine must always be switched off.
- Machine must be raised and placed into its central position.
- Speed must be kept to a minimum especially on bumpy roads or terrain.
- Always abide with local laws and road regulations.
- Be aware of the machines width.

DETACHMENT & STORAGE

Detaching the machine from the tractor

- Removal of the machine should be performed on a firm level site. The procedure for detachment is as follows:
- Place the machine in its central position.
- Gently lower the machine fully to the ground.
- Switch off the tractor and remove its starting key.
- Detach hydraulic hoses from the tractor service and stow them neatly on the machine.
- Remove the PTO driveshaft.
- 'Chock' the rear roller to prevent movement of the machine during the detachment procedure and whilst in storage.
- Remove the top link and both pins from the lower attachment points.
- Carefully and slowly drive the tractor clear of the machine.
- Clean and lubricate the machine in preparation for next use.

Storage

For extended periods of storage it is advisable that the machine be kept in a clean dry environment protected from the elements to avoid risk of corrosion. The machine should be thoroughly cleaned and lubricated prior to storage. At this point it is good practice to check the machine for worn or damaged components - any parts that require replacing should be ordered and fitted at the earliest opportunity so the machine is fully prepared for the next seasons work.

MAINTENANCE

All maintenance, cleaning and repair operations must be performed with the machine firmly lowered to the ground and detached from the tractor or with the PTO disconnected, engine switched off and starting key removed. For any repairs or maintenance that requires access from underneath, the machine should be firmly and safely raised and propped using suitable purpose designed supports capable of bearing the machines full weight. Care should be adopted at all times when working with or under a raised machine.

MAINTENANCE TASKS

The following preventive maintenance tasks should be performed at the timescales stated to both maximise efficiency and prolong the working life of the machine.

After first 2 hours of work - new machine or machine fitted with new belts.

- ✓ Check all nuts and bolt for tightness – *retighten if required.*
- ✓ Check belt tension and adjust if required – *refer to belt section for details of adjustment.*

After every 8 hours of work

- ✓ Check all nuts and bolt for tightness – *retighten if required.*
- ✓ Check belt tension and adjust if required – *refer to belt section for details of adjustment.*
- ✓ Check wear and condition of flails – *replacing missing, or damaged flails immediately.*
- ✓ Check condition of safety guards – *repair or replace if not performing their function.*
- ✓ Lubricate grease points – *see below for locations of the machines grease points.*
- ✓ Check gearbox oil level – *top up if required.*
- ✓ Check rotor – *remove foreign objects that may be fouling or lodged in the rotor.*
- ✓ Check frame and 3-point hitch – *ensure all components are in a safe working condition.*

After every 100 hours

- ✓ Grease PTO driveshaft – *separate telescopic drive and apply grease to internal shaft.*

Every 12 months

- ✓ Change gearbox oil

Grease Points

Lubricate the points indicated below using type LIS 3 grease.

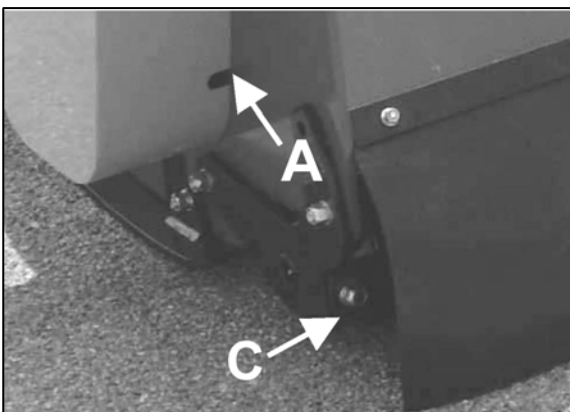

A. Rotor Shaft L/H Bearing
C. Rear Roller L/H Bearing

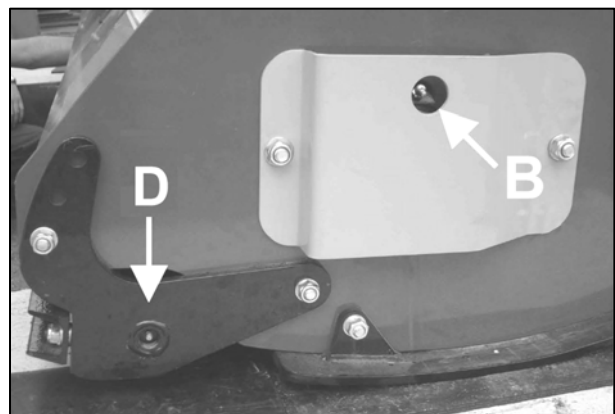

B. Rotor Shaft R/H Bearing
D. Rear Roller R/H Bearing

Gearbox Lubrication

The illustrations opposite show the lubrication access points for the gearbox and the half shaft drive.

- A. Filler Plug
- B. Level Plug
- C. Drain Plug

Lubricant level should be checked on a daily basis during work and topped up only if required.

Checking the level is by removal of plug 'B' – lubricant should be inline with the bottom of this aperture. Topping up the lubricant is performed via filler plug 'A' to a point where the oil starts to drip out of plug 'B' aperture. Replace and tighten the plugs before using the machine.

Gearbox oil should be replaced annually – draining the gearbox is via plug 'C'.

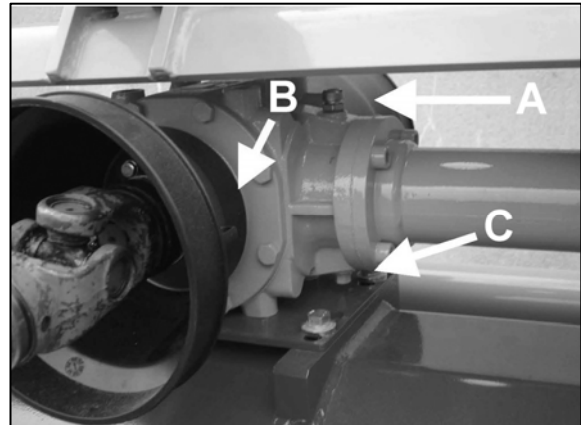

Gearbox - lubrication access points

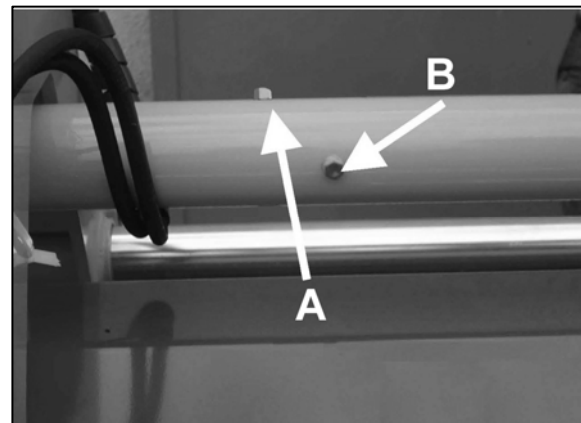

Half Shaft - lubrication access points

Capacities & Lubricant

Gearbox

1.5 Litre SAE90 – *All models*

Half Shaft

0.9 Litre SAE90 – *Euro 230 & Euro 250 models*

1.3 Litre SAE90 – *Euro 280 model*

Flail replacement

The rotor and flails should be inspected for wear or damage on a regular basis – missing, damaged or worn flails should be replaced immediately. When replacing a flail the diametrically opposite flail should also be replaced at the same time in order to maintain rotor balance.

DANGER: Machine and tractor should be switched off and the starting key removed at all times when inspecting or maintaining the machine – Never work on a machine that is switch on and running.

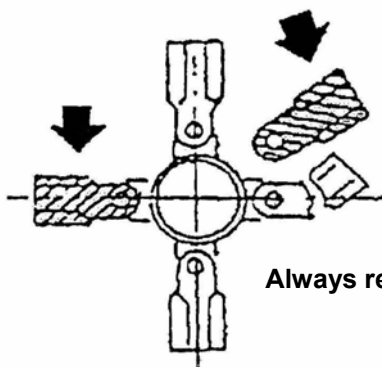

Always replace flails in opposing pairs

Rotor Vibration

If vibration of the rotor is experienced the machine should be stopped immediately – this is often a sign that a flail is either missing or severely damaged, if this is the case do not use the machine until the problem has been rectified. If vibration continues, or occurs for no apparent reason, the rotor must be checked and, if necessary, rebalanced before using the machine again. Contact your local dealer for further advice or assistance on this subject.

TROUBLESHOOTING

PROBLEM	POSSIBLE CAUSES	REMEDIES
Irregular Cut	Worn, bent or broken flails	<i>Replace flails</i>
	RPM too low	<i>Increase RPM</i>
	Machine not level to the ground	<i>Correct mounting on tractor</i>
	Clogged material caused by excessive forward speed	<i>Reduce forward speed</i>
Noise	Loose bolts	<i>Check and tighten bolts</i>
	Damaged components	<i>Repair or replace</i>
Noisy gearbox	Lack of lubrication	<i>Top up oil to correct level</i>
	Worn gears	<i>Replace worn components</i>
	Worn bearings	<i>Replace worn components</i>
Vibration	Broken, worn or missing flails	<i>Replace flails</i>
	Rotor out of balance	<i>Balance or replace rotor</i>
	Worn rotor bearings	<i>Replace rotor bearings</i>
Excessive backlash in joints	Worn pins	<i>Replace pins</i>
Tight bearings	Bearings dirty or ungreased	<i>Clean and grease</i>
	Violent lowering down of machine	<i>Lower machine gently</i>
Belts overheating	Belts slipping on pulleys	<i>Tension belts</i>
	Flails contacting the ground	<i>Raise cutting height</i>
	Working speed too high	<i>Reduce working speed</i>

Machine Disposal

Disposal of this machine and any of its component parts must be performed in a responsible and inoffensive manner respecting all current laws relating to this subject. Materials forming this machine that must undergo differentiated division and disposal are:

- Steel
- Mineral Oil
- Rubber
- Plastic

TORNADO

EURO & EURO OPEN

Models 230, 250 & 280

Machines 04/14▶

Parts Manual

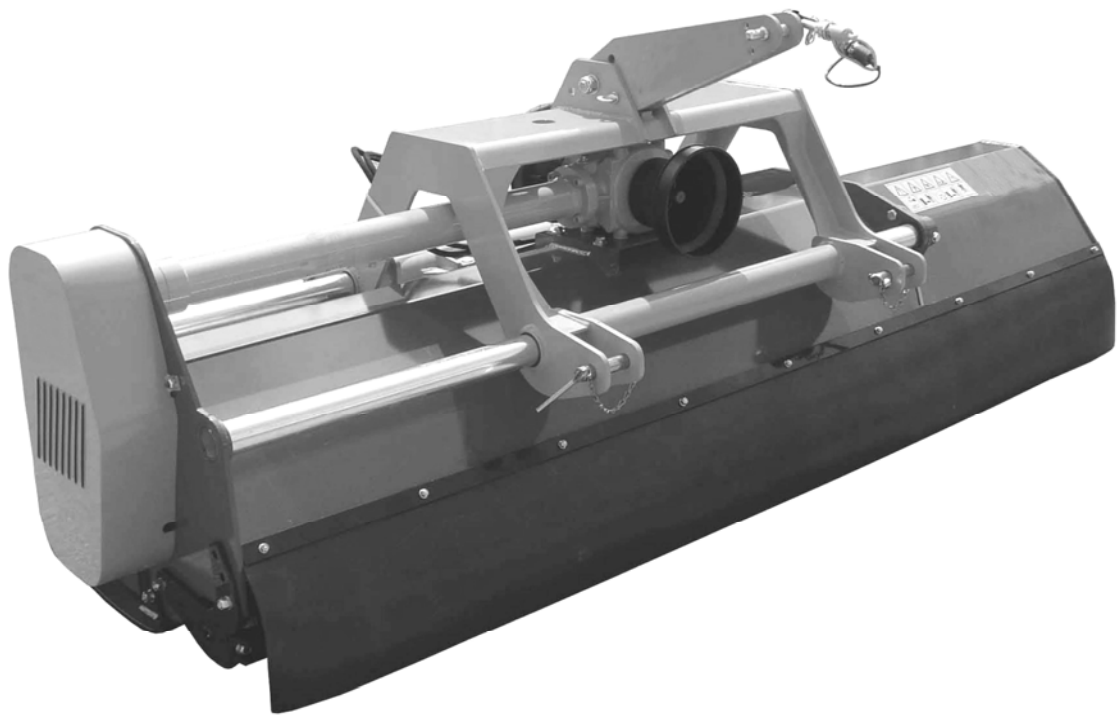

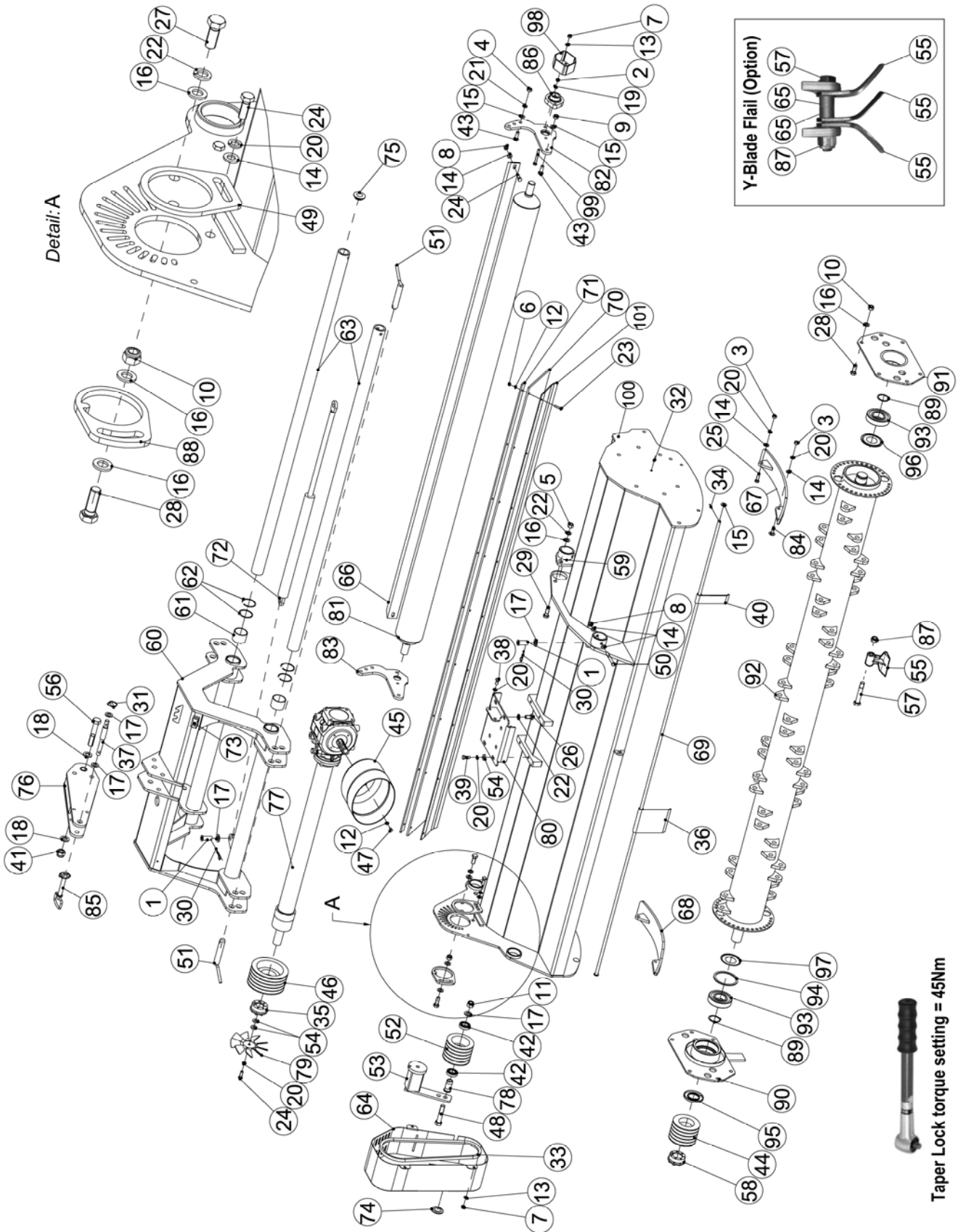

Taper Lock torque setting = 45Nm

MAIN ASSEMBLY – EURO 230/250/280 – 04/16▶

REF.	DESCRIPTION	PART No.	QUANTITY		
			230	250	280
1	PIVOT PIN	1061532	2	2	2
2	NUT	9113005	4	4	4
3	NUT	9113006	4	4	4
4	NUT	1061121	2	2	2
5	NUT	9113007	2	2	2
6	SELF-LOCKING NUT	9163004	7	8	9
7	SELF-LOCKING NUT	9163005	7	7	7
8	SELF-LOCKING NUT	9163006	4	4	4
9	SELF-LOCKING NUT	1061042	2	2	2
10	SELF-LOCKING NUT	9163007	13	13	13
11	SELF-LOCKING NUT	9163008	1	1	1
12	WASHER	9100104	15	16	17
13	WASHER	9100105	7	7	7
14	WASHER	9100106	15	19	21
15	WASHER	05.281.14	9	9	9
16	WASHER	9100106	17	17	17
17	WASHER	9100108	5	5	5
18	WASHER	9100109	2	2	2
19	SPRING WASHER	9100205	4	4	4
20	SPRING WASHER	9100208	12	12	12
21	SPRING WASHER	05.282.08	2	2	2
22	SPRING WASHER	9100206	7	7	7
23	BOLT	9313074	7	8	9
24	BOLT	9313076	4	4	4
25	BOLT	9213086	2	2	2
26	BOLT	9313067	4	4	4
27	BOLT	9313087	1	1	1
28	BOLT	9313097	13	13	13
29	BOLT	9313107	2	2	2
30	PIN	1061076	2	2	2
31	LYNCH PIN	1061097	1	1	1
32	GREASE NIPPLE	1061079	2	2	2
33	BELT	1062285	4	5	5
34	SPLIT PIN	1061077	1	1	1
35	CLUTCH ELVE	1061165	1	1	1
36	FLAP	1061171	16	12	19
37	PIN	1061168	1	1	1
38	BOLT	9313056	2	2	2
39	BOLT	9313066	4	4	4
40	FLAP (50mm)	1061482	-	-	1
	FLAP (70mm)	1061170	-	1	-
	FLAP (130mm)	1061098	-	5	-
41	NUT	9163009	1	1	1

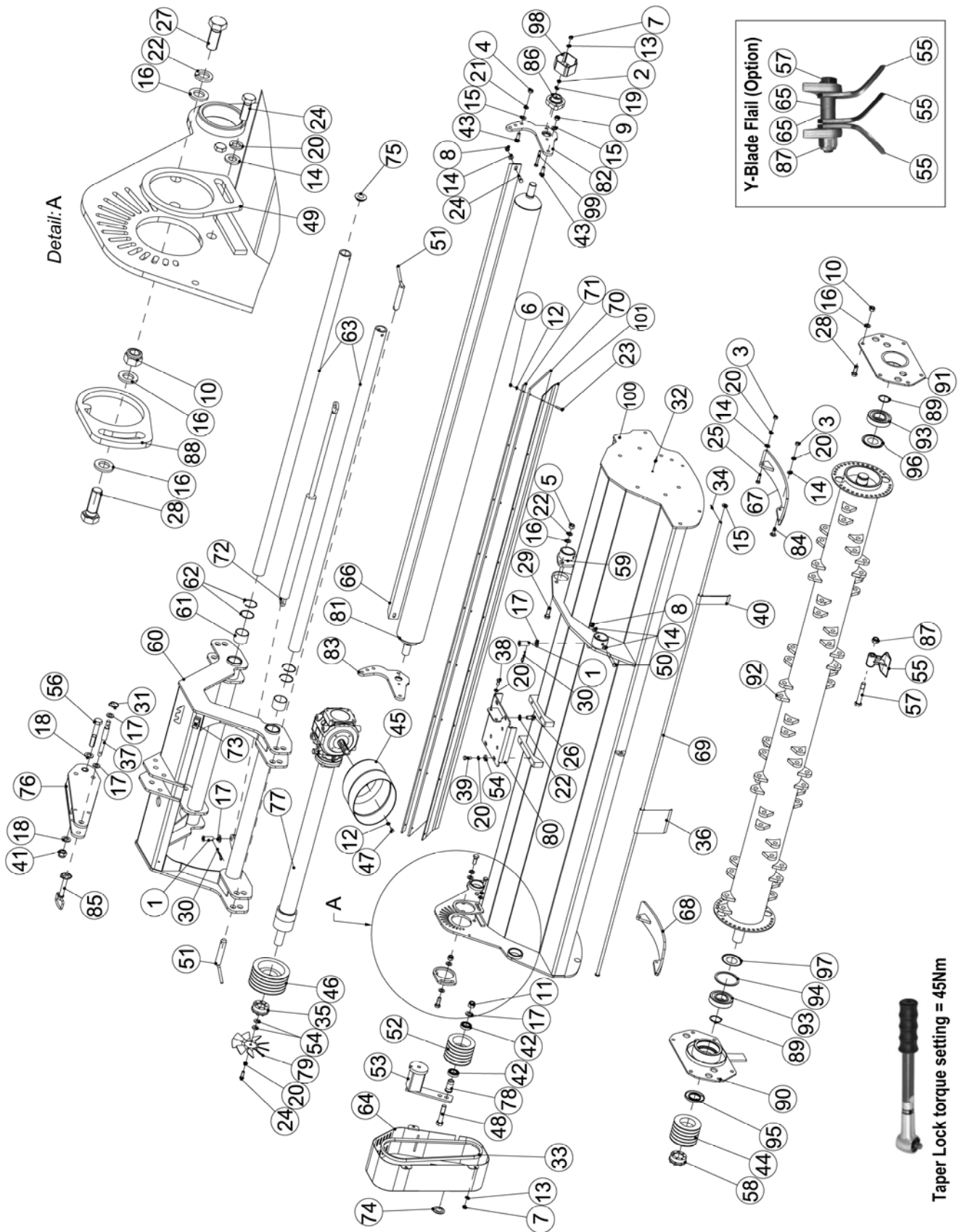

 Taper Lock torque setting = 45Nm

MAIN ASSEMBLY – EURO 230/250/280 – 04/16▶

REF.	DESCRIPTION	PART No.	QUANTITY		
			230	250	280
42	BEARING	1061336	2	2	2
43	BOLT	1061687	4	4	4
44	PULLEY 130/80-4	1061113	1	-	-
	PULLEY 130/80-5	1061479	-	1	1
45	PVC SHAFT GUARD	1061246	2	2	2
46	PULLEY 180/80-4	1061114	1	-	-
	PULLEY 180/80-5	1061414	-	1	1
47	BOLT	1061531	8	8	8
48	BOLT	1061556	1	-	-
	BOLT	1061555	-	1	1
49	FLANGE	1061142	1	1	1
50	BOLT	9213206	2	2	2
51	PIVOT PIN	1061268	2	2	2
52	STRAIN PULLEY 130/4	1061049	1	-	-
	STRAIN PULLEY 130/5	1061335	-	1	1
53	BELT TENSIONER	1061539	1	1	1
54	WASHER (THICK)	1062112	-	-	4
55	HAMMER FLAIL	1062286	26	28	32
	Y-BLADE FLAIL (OPTION)	1061034	78	84	96
56	BOLT	1061557	1	1	1
57	BOLT	1061530	26	28	32
58	CLUTCH ELVE	1061490	1	1	1
59	BUSHING	1061572	1	1	1
60	LINKAGE - LH	1061567	1	1	1
61	BUSHING	1061493	4	4	4
62	CIRCLIP	1061494	4	4	4
63	SLIDING TUBE	1061496	-	-	2
	SLIDING TUBE	1061495	2	2	-
64	BELT SHIELD - LH	1061571	1	1	1
65	SPACER <i>(For use with Y-Blade Flails only)</i>	1061501	52	56	64
66	SCRAPER - EURO 230	1061507	1	-	-
	SCRAPER - EURO 250	1061508	-	1	-
	SCRAPER - EURO 280	1061509	-	-	1
67	SKID (LEFT)	1061510	1	1	1
68	SKID (RIGHT)	1061511	1	1	1
69	FLAP BAR 230	1061512	1	-	-
	FLAP BAR 250	1061513	-	1	-
	FLAP BAR 280	1061514	-	-	1
70	RUBBER GUARD - EURO 230	1062295	1	-	-
	RUBBER GUARD - EURO 250	1062296	-	1	-
	RUBBER GUARD - EURO 280	1062297	-	-	1
71	BAR (RUBBER GUARD) - 230	1061518	1	-	-
	BAR (RUBBER GUARD) - 250	1061519	-	1	-
	BAR (RUBBER GUARD) - 280	1061520	-	-	1

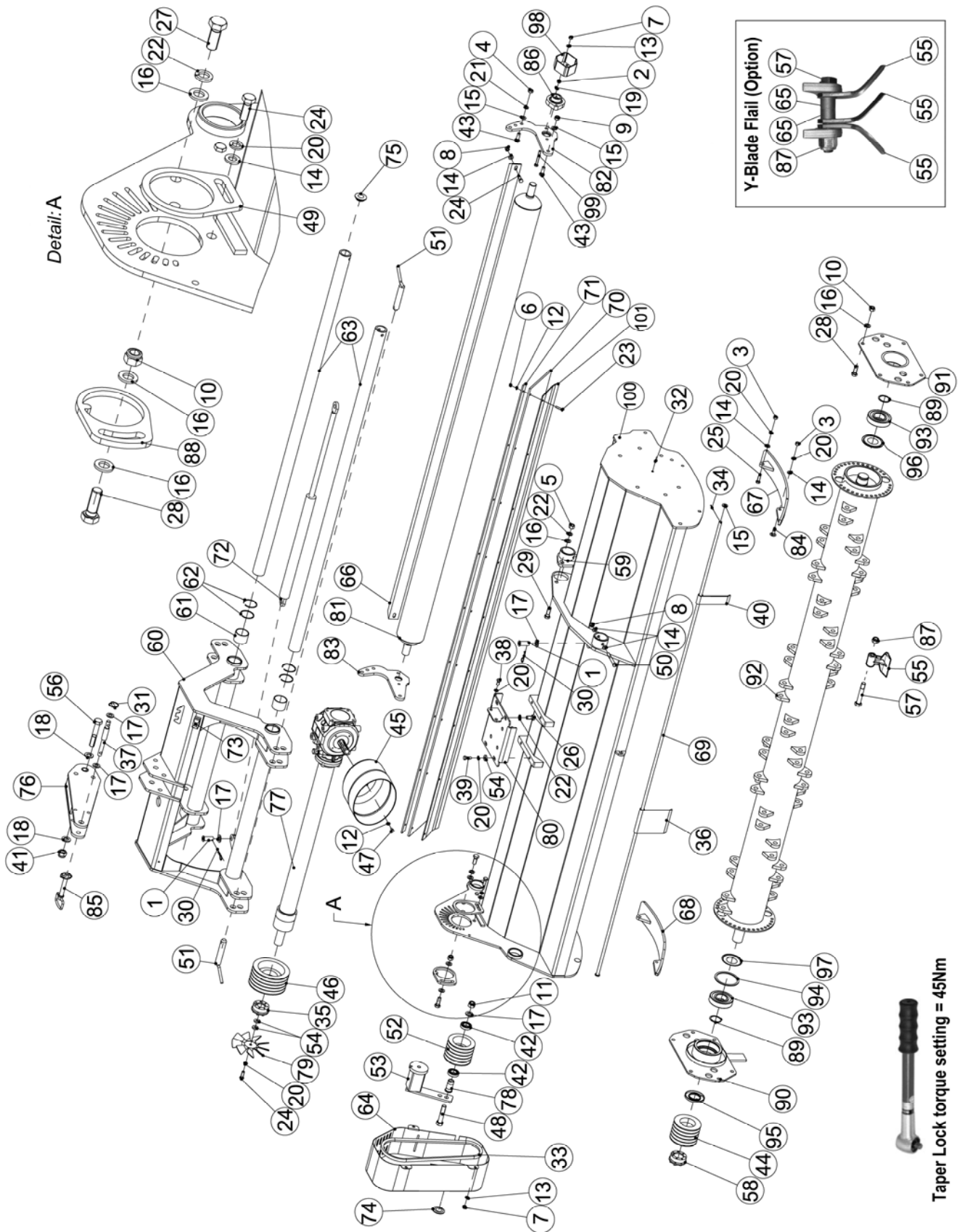

Detail: A

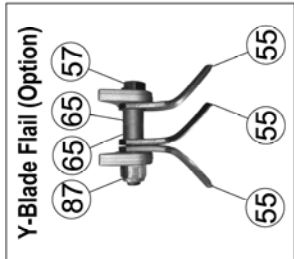

Taper Lock torque setting = 45Nm

MAIN ASSEMBLY – EURO 230/250/280 – 04/16▶

REF.	DESCRIPTION	PART No.	QUANTITY		
			230	250	280
72	HYDRAULIC CYLINDER	1061523	1	1	1
73	CLAMP	1061559	1	1	1
74	BELT SHIELD CAP	1062046	1	1	1
75	CAP	1061561	4	4	4
76	UPPER LINKAGE	1061562	1	1	1
77	GEARBOX 312 950 - LH	1061575	1	1	-
	GEARBOX 312 1200 - LH	1061574	-	-	1
78	BUSHING FOR STRAIN PULLEY	1061622	1	-	-
	BUSHING FOR STRAIN PULLEY	1061565	-	1	1
79	FAN	1062128	1	1	1
80	GEARBOX PLATE - LH	1061689	1	1	1
81	REAR ROLLER 230	1062287	1	-	-
	REAR ROLLER 250	1062288	-	1	-
	REAR ROLLER 280	1062289	-	-	1
82	REAR ROLLER BRACKET LH	1062291	1	1	1
83	REAR ROLLER BRACKET RH	1062290	1	1	1
84	BOLT	9213086	2	2	2
85	PIN c/w CHAIN	1062172	1	1	1
86	BEARING & CASING	1062138	2	2	2
87	NUT	1062173	26	28	32
88	FLANGE	1062174	1	1	1
89	EXTERNAL CIRCLIP	1062175	2	2	2
90	BEARING CASING (L)	1062176	1	1	1
91	BEARING CASING (R)	1062177	1	1	1
92	ROTOR SHAFT c/w BEARING - 230	1062292	1	-	-
	ROTOR SHAFT c/w BEARING - 250	1062293	-	1	-
	ROTOR SHAFT c/w BEARING - 280	1062294	-	-	1
93	BEARING	1062181	2	2	2
94	INTERNAL CIRCLIP	1062182	1	1	1
95	OIL WASHER	1062183	1	1	1
96	WASHER	1062184	1	1	1
97	WASHER	1062185	1	1	1
98	BEARING GUARD	1062186	2	2	2
99	BOLT	1062187	4	4	4
100	FRAME - 230 LH	1062188	1	1	1
	FRAME - 250 LH	1062189	1	1	1
	FRAME - 280 LH	1062190	1	1	1
101	FLAP SUPPORT - 230	1062191	1	-	-
	FLAP SUPPORT - 250	1062192	-	1	-
	FLAP SUPPORT - 280	1062193	-	-	1
*	HYDRAULIC OFFSETTING PIPES (2000)	1061581	1	1	1
*	HYDRAULIC OFFSETTING PIPES (2500)	1061582	1	1	1
*	PTO SHAFT	1061690	1	1	1

* Components not illustrated

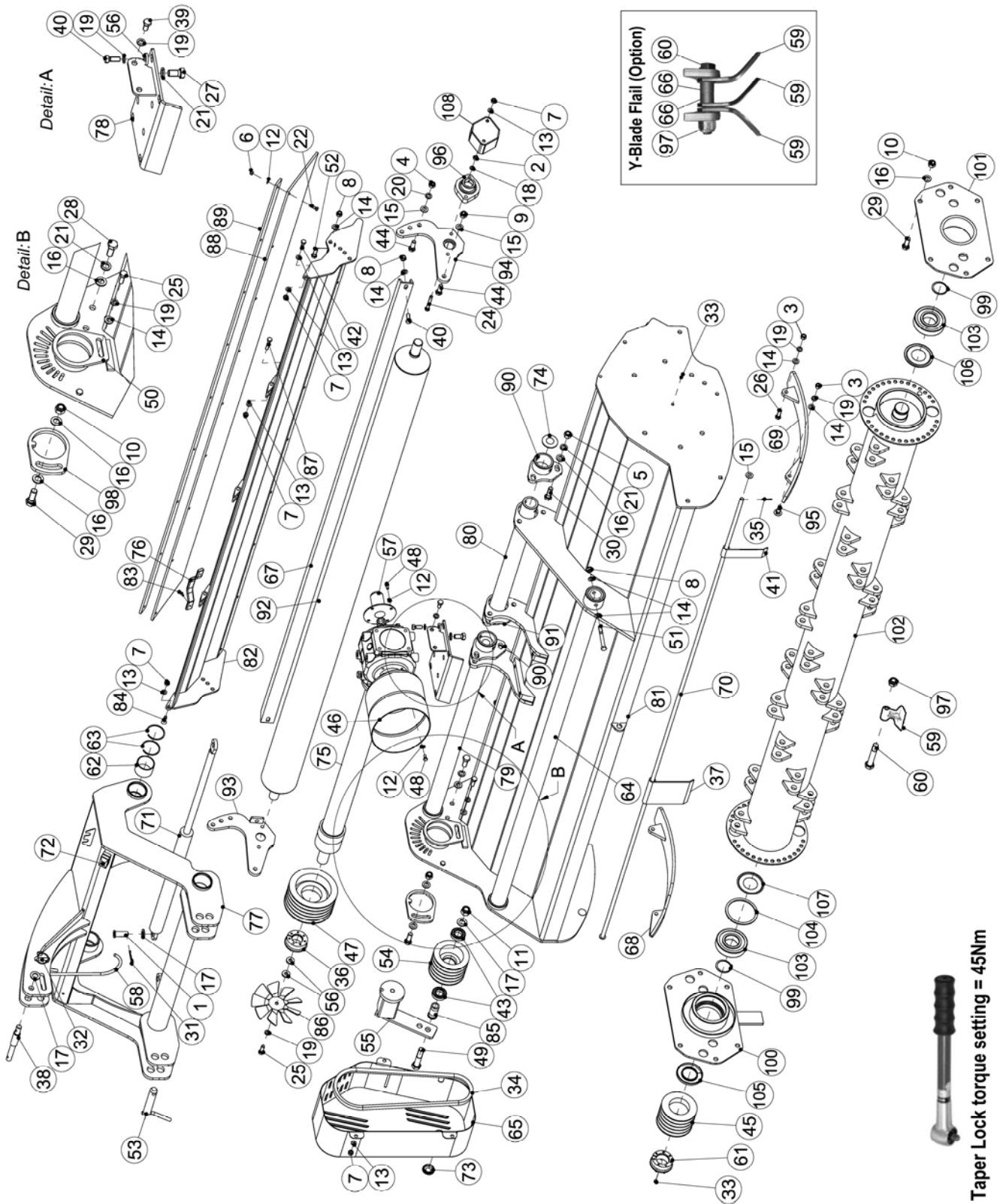

MAIN ASSEMBLY – EURO OPEN 230/250/280 – 04/16▶

REF.	DESCRIPTION	PART No.	QUANTITY		
			230	250	280
1	PIVOT PIN	1061532	2	2	2
2	NUT	9113005	4	4	4
3	NUT	9113006	4	4	4
4	NUT	1061121	2	2	2
5	NUT	9113007	6	6	6
6	SELF-LOCKING NUT	9163004	7	8	9
7	SELF-LOCKING NUT	9163005	11	11	11
8	SELF-LOCKING NUT	9163006	7	7	7
9	SELF-LOCKING NUT	1061042	2	2	2
10	SELF-LOCKING NUT	9163007	13	13	13
11	SELF-LOCKING NUT	9163008	1	1	1
12	WASHER	9100104	15	16	17
13	WASHER	9100105	13	13	13
14	WASHER	9100106	13	13	13
15	WASHER	05.281.14	5	5	5
16	WASHER	9100106	21	21	21
17	WASHER	9100108	4	4	4
18	SPRING WASHER	9100205	5	5	5
19	SPRING WASHER	9100206	12	12	12
20	SPRING WASHER	05.282.08	2	2	2
21	SPRING WASHER	9100207	11	11	11
22	BOLT	9213064	7	8	9
23	BOLT	9313045	7	8	9
24	BOLT	9213165	4	4	4
25	BOLT	9313076	2	2	2
26	BOLT	9213086	2	2	2
27	BOLT	9313067	4	4	4
28	BOLT	1061047	1	1	1
29	BOLT	9313097	13	13	13
30	BOLT	9213107	6	6	6
31	PIN	1062197	2	2	2
32	LYNCH PIN	1061097	1	1	1
33	GREASE NIPPLE	1061079	2	2	2
34	BELT	1062285	4	5	5
35	SPLIT PIN	1061077	1	1	1
36	CLUTCH ELVE	1061165	1	1	1
37	FLAP	1061171	16	12	19
38	PIN	1061168	1	1	1
39	BOLT	9313056	2	2	2
40	BOLT	9313066	6	6	6
41	FLAP (50mm)	1061482	-	-	1
	FLAP (70mm)	1061170	-	1	-
	FLAP (130mm)	1061098	-	5	-

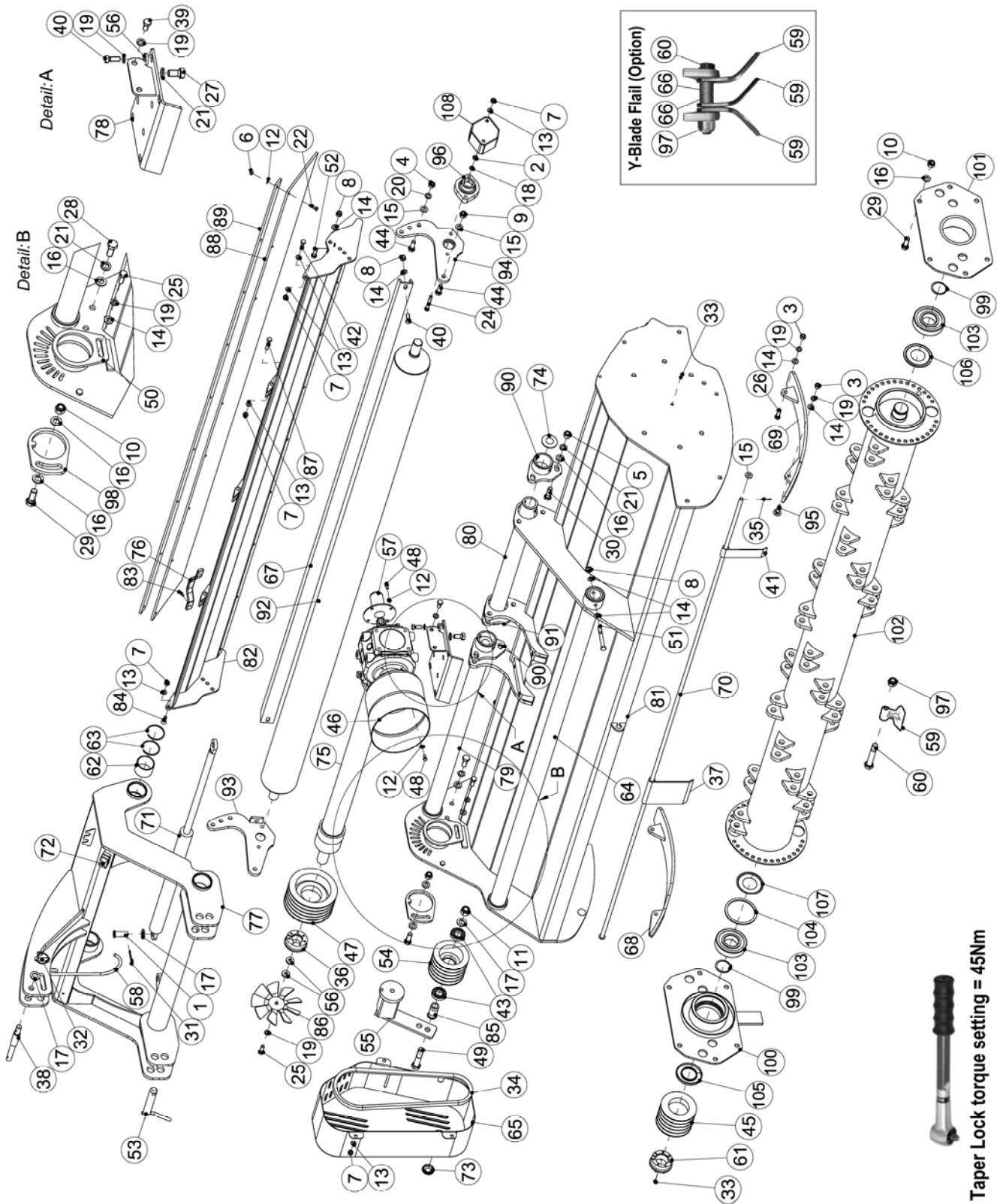

MAIN ASSEMBLY – EURO OPEN 230/250/280 – 04/16▶

REF.	DESCRIPTION	PART No.	QUANTITY		
			230	250	280
42	NUT	9213085	1	1	1
43	BEARING	1061336	2	2	2
44	BOLT	1061687	4	4	4
45	PULLEY 130/80-4	1061113	1	-	-
	PULLEY 130/80-5	1061479	-	1	1
46	PVC SHAFT GUARD	1061484	1	1	1
47	PULLEY 180/80-4	1061114	1	-	-
	PULLEY 180/80-5	1061414	-	1	1
48	BOLT	1061531	8	8	8
49	BOLT	1061556	1	-	-
	BOLT	1061555	-	1	1
50	FLANGE	1061142	1	1	1
51	BOLT	9213206	3	3	3
52	BOLT	9213086	2	2	2
53	PIVOT PIN	1061268	2	2	2
54	STRAIN PULLEY 130/4	1061049	1	-	-
	STRAIN PULLEY 130/5	1061335	-	1	1
55	BELT TENSIONER	1061539	1	1	1
56	WASHER	9100106	6	6	6
57	SHIELD CAP	1061552	1	1	1
58	PTO HOOK	1061551	1	1	1
59	HAMMER FLAIL	1062286	26	28	32
	Y-BLADE FLAIL (OPTION)	1061034	78	84	96
60	BOLT	1061530	26	28	32
61	CLUTCH ELVE	1061490	1	1	1
62	BUSHING	1061493	4	4	4
63	CIRCLIP	1061494	4	4	4
64	SLIDING TUBE	1061496	-	-	1
	SLIDING TUBE	1061495	1	1	-
65	BELT SHIELD - LH	1061571	1	1	1
66	SPACER <i>(For use with Y-Blade Flails only)</i>	1061501	52	56	64
67	SCRAPER - EURO 230	1061507	1	-	-
	SCRAPER - EURO 250	1061508	-	1	-
	SCRAPER - EURO 280	1061509	-	-	1
68	SKID (RIGHT)	1061511	1	1	1
69	SKID (LEFT)	1061510	1	1	1
70	FLAP BAR 230	1061512	1	-	-
	FLAP BAR 250	1061513	-	1	-
	FLAP BAR 280	1061514	-	-	1
71	HYDRAULIC CYLINDER	1061523	1	1	1
72	CLAMP	1061559	1	1	1
73	BELT SHIELD CAP	1062046	1	1	1
74	CAP	1061561	5	5	5

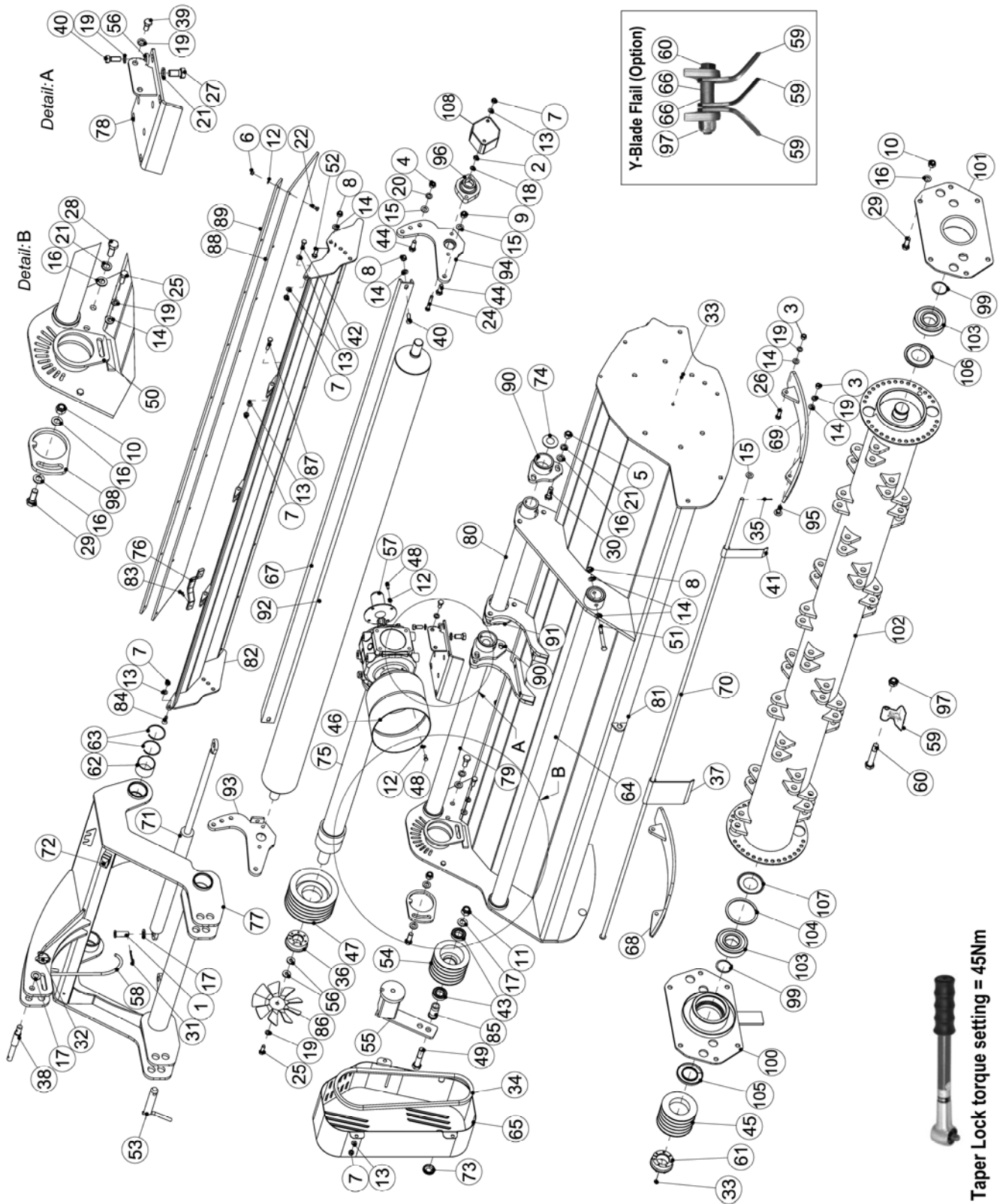

MAIN ASSEMBLY – EURO OPEN 230/250/280 – 04/16▶

REF.	DESCRIPTION	PART No.	QUANTITY		
			230	250	280
75	GEARBOX 312 950 - LH	1061575	1	1	-
	GEARBOX 312 1200 - LH	1061574	-	-	1
76	HANDLE	1062152	2	2	2
77	LINKAGE	1062153	1	1	1
78	GEARBOX PLATE - LH	1062118	1	1	1
79	SLIDING TUBE	1062236	1	1	-
	SLIDING TUBE	1062119	-	-	1
80	SLIDING TUBE	1062120	1	1	-
	SLIDING TUBE	1062121	-	-	1
81	FRAME 230	1062240	1	-	-
	FRAME 250	1062241	-	1	-
	FRAME 280	1062242	-	-	1
82	REAR GATE 230	1062125	1	-	-
	REAR GATE 250	1062126	-	1	-
	REAR GATE 280	1062127	-	-	1
83	BOLT	1062239	4	4	4
84	BOLT	1062243	1	1	1
85	BUSHING FOR STRAIN PULLEY	1061622	1	-	-
	BUSHING FOR STRAIN PULLEY	1061565	-	1	1
86	FAN	1062128	1	1	1
87	BOLT	1062129	3	3	3
88	RUBBER GUARD 230	1062130	1	-	-
	RUBBER GUARD 250	1062131	-	1	-
	RUBBER GUARD 280	1062132	-	-	1
89	BAR (RUBBER GUARD) 230	1062133	1	-	-
	BAR (RUBBER GUARD) 250	1062134	-	1	-
	BAR (RUBBER GUARD) 280	1062135	-	-	1
90	BUSHING (L)	1062136	2	2	2
91	BUSHING (R)	1062137	1	1	1
92	REAR ROLLER 230	1062287	1	-	-
	REAR ROLLER 250	1062288	-	1	-
	REAR ROLLER 280	1062289	-	-	1
93	REAR ROLLER BRACKET RH	1062290	1	1	1
94	REAR ROLLER BRACKET LH	1062291	1	1	1
95	BOLT	9213086	2	2	2
96	BEARING & CASING	1062138	2	2	2
97	NUT	1062173	26	28	32
98	FLANGE	1062174	1	1	1
99	EXTERNAL CIRCLIP	1062175	2	2	2
100	BEARING CASING (L)	1062176	1	1	1
101	BEARING CASING (R)	1062177	1	1	1

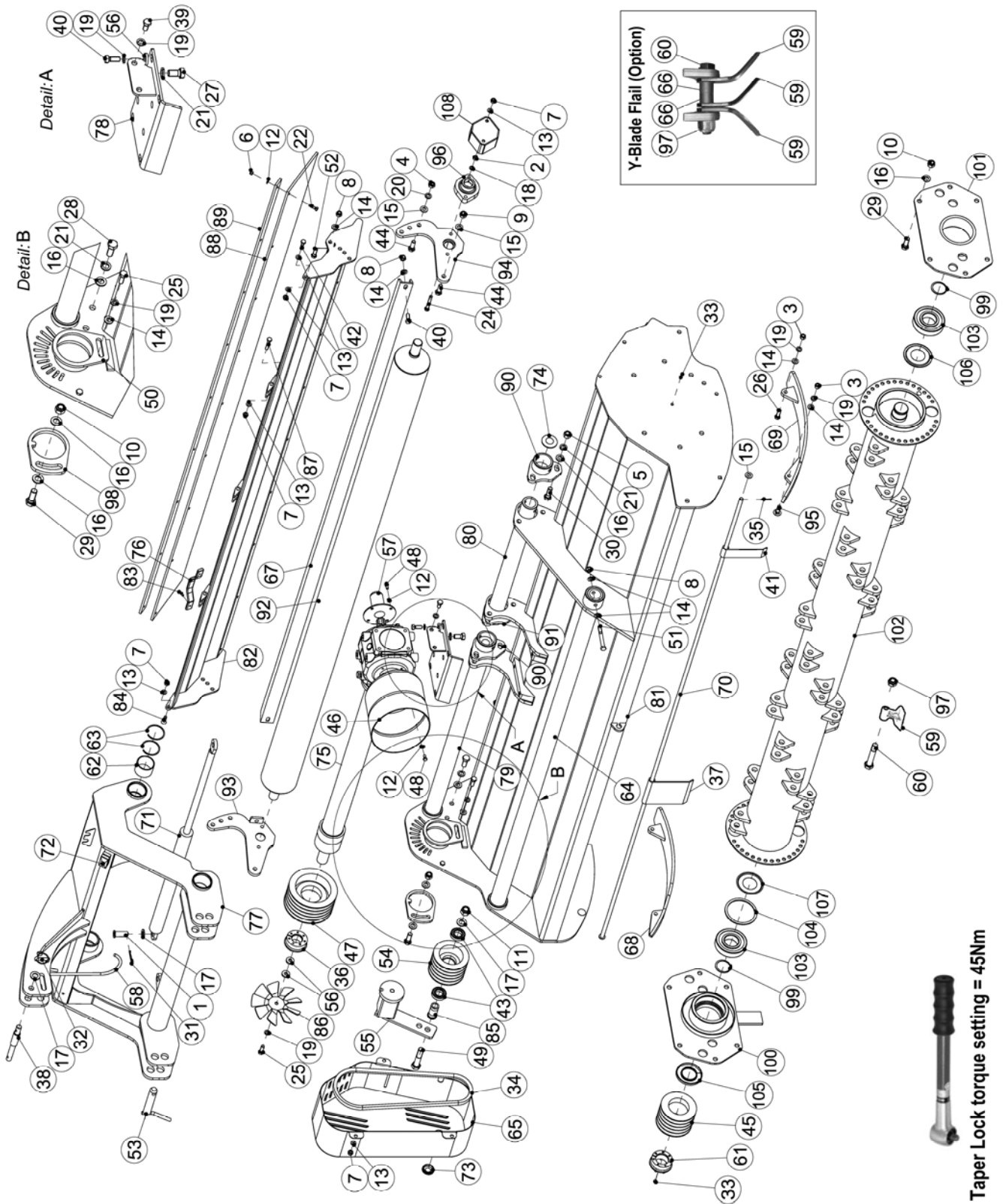

Taper Lock torque setting = 45Nm

REF.	DESCRIPTION	PART No.	QUANTITY		
			230	250	280
102	ROTOR SHAFT c/w BEARING 230	1062292	1	-	-
	ROTOR SHAFT c/w BEARING 250	1062293	-	1	-
	ROTOR SHAFT c/w BEARING 280	1062294	-	-	1
103	BEARING	1062181	2	2	2
104	INTERNAL CIRCLIP	1062182	1	1	1
105	OIL WASHER	1062183	1	1	1
106	WASHER	1062184	1	1	1
107	WASHER	1062185	1	1	1
108	BEARING GUARD	1062186	2	2	2
*	HYDRAULIC OFFSETTING PIPES (2000)	1062234	1	1	1
*	HYDRAULIC OFFSETTING PIPES (2500)	1062235	1	1	1
*	PTO SHAFT	1062246	1	-	-
*	PTO SHAFT	1061690	-	1	1

* *Components not illustrated*

SUPPORT WHEELS ASSEMBLY (Option)

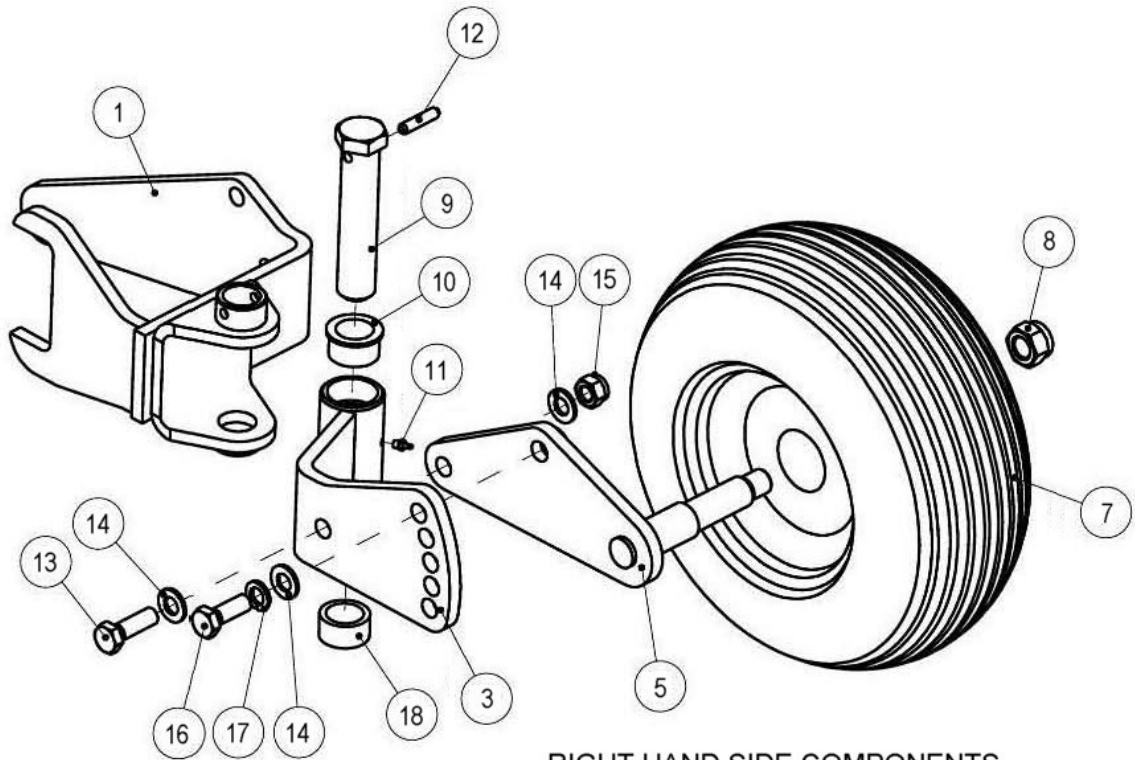

RIGHT HAND SIDE COMPONENTS

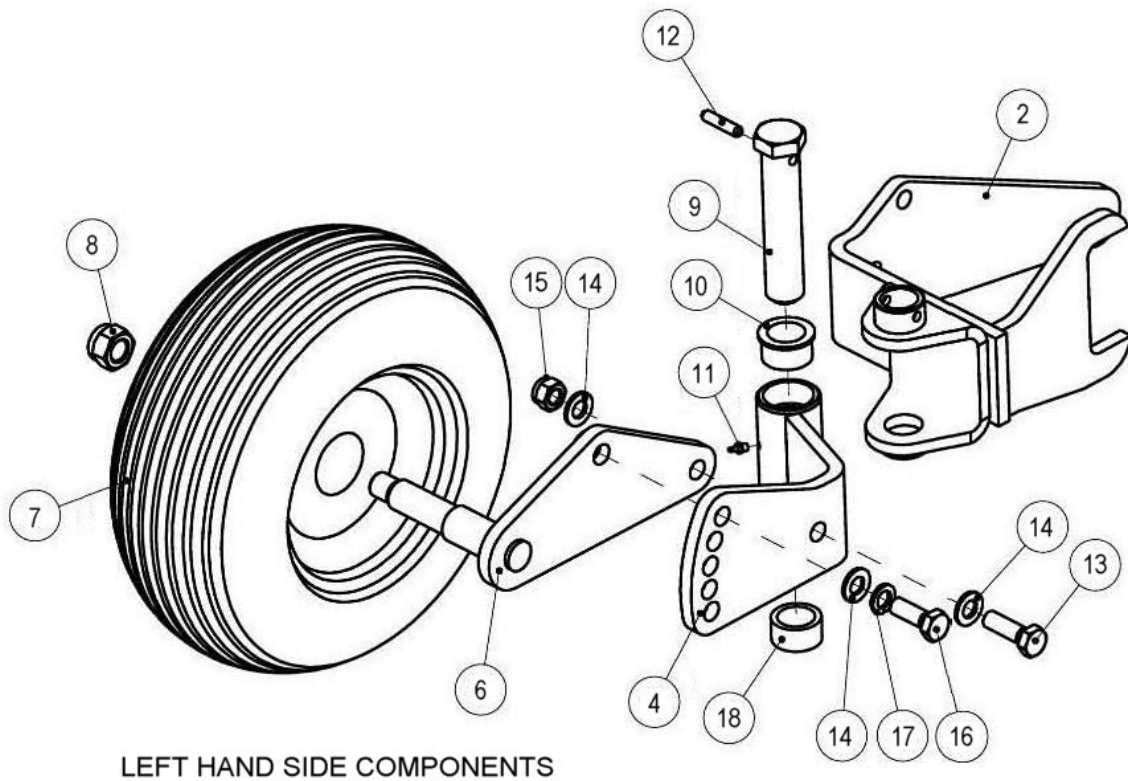

LEFT HAND SIDE COMPONENTS

SUPPORT WHEELS ASSEMBLY (Option)

REF.	DESCRIPTION	PART No.	QUANTITY		
			230	250	280
	SUPPORT WHEEL MODULE (OPTION)	1062150			
1	BRACKET SUPPORT RH	1062147	1	1	1
2	BRACKET SUPPORT LH	1062148	1	1	1
3	WHEEL BRACKET RH	1062143	1	1	1
4	WHEEL BRACKET LH	1062144	1	1	1
5	WHEEL AXLE RH	1062145	1	1	1
6	WHEEL AXLE LH	1062146	1	1	1
7	WHEEL	1062139	2	2	2
8	NUT	9113008	2	2	2
9	PIN	1062141	2	2	2
10	BUSHING	1062142	2	2	2
11	GREASE NIPPLE	1061554	2	2	2
12	PIN	1062149	2	2	2
13	BOLT	1062140	2	2	2
14	WASHER	05.281.14	6	6	6
15	NUT	1062108	2	2	2
16	BOLT	1061687	2	2	2
17	WASHER	05.282.08	2	2	2
18	BUSHING	1061337	2	2	2

