

Fransgård

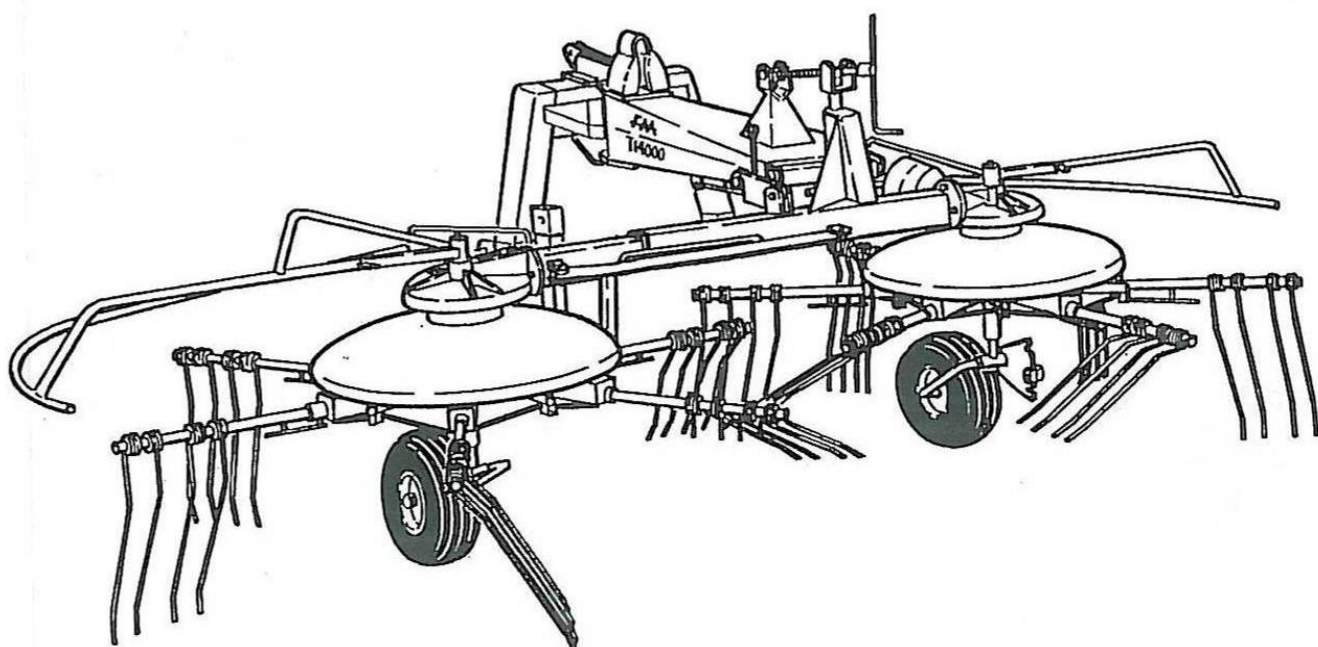

Manual



GB



Universal Haymaker

TI-4000
TI-4000S

Fransgård	
Fredbjergvej 132, Denmark-9640 Farsø www.fransgard.dk	
Model	TI-4000
Kg.	420
KW	30
Serie nr.	
	
	
Made in Denmark	

Fransgård	
Fredbjergvej 132, Denmark-9640 Farsø www.fransgard.dk	
Model	TI-4000S
Kg.	420
KW	30
Serie nr.	
	
	
Made in Denmark	

Fransgård Maskinfabrik A/S
Fredbjergvej 132
DK - 9640 Farsø
Telefon : +45 98 63 21 22
Fax : +45 98 63 18 65
www.fransgard.dk
mail@fransgard.dk

LIST OF CONTENTS

Page

Technical Specifications	1
Safety Precautions	2
Introduction	2
Mounting	2
Raking up.....	3
Tedding.....	3
Transport position.....	3
Ordering Spare Parts.....	4
Lubrication and Maintenance.....	4

TECHNICAL SPECIFICATIONS

Working width TI-4000.....	3,40 m / 11,5' - 4,00 m / 13,5'
Working width TI-4000S	3,60 m / 11,8' - 4,20 m / 13,8'
Transport width	2,15 m/7,1'
Working speed, up to.....	10-15km/h / 7-10 mph
Power requirement	40hp / 30kW.
PTO	400 - 540 rpm.
Tire size	16,5 x 6,5-6 ply.
Weight	425 kg / 937 lbs.
Number of tines	24 pieces

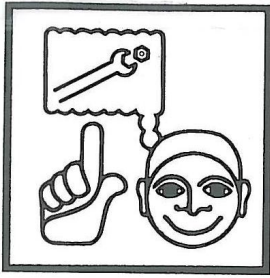

SAFETY PRECAUTIONS

All screens must be correctly positioned and checked before starting the tedder. It is not advisable to remain in the working area of the tedder while working parts are rotating.

The machine is made to work in hay and straw crops, and must not be used for anything else.

The machine must only be operated by qualified operator.

Machine lubrication, adjustment and setting may only take place while the tedder is not in use and while the power take-off is switched off.

Tighten bolts and check settings after approx. 5 hours of use.

Only use original Fransgård spare parts.

Read instructions for use carefully before starting.

INTRODUCTION

The Fransgård Combirake model TI-4000 / TI-4000S is one of the fastest and most effective combirakes on the global market, and has all the working functions: tedding, turning over and raking up.

For tedding, the rake arms are in the locked position, and the machine leans forward to level the material evenly.

For raking up, the rake arms are cam-track controlled so in the fact that the tines tilt upwards, allowing the material to be treated very gently.

When driving with the top bar handle in floating position, the bolt (42400) has to be removed and the top bar adjusted as shown in the illustration.

The machine is fitted with balloon tires with a wide bearing surface. The rotor speed and forward speed of the tractor must be selected on the basis of the type and state of the crop.

PTO: Tedding and turning over, 400-max. 500 rpm.

PTO: Raking up, 350-max. 400 rpm.

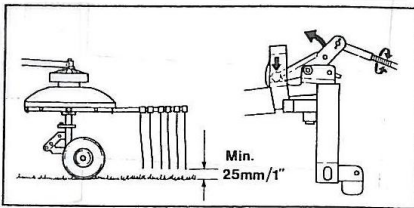
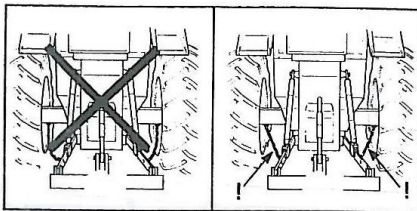

MOUNTING

Mount the connecting frame (55006) on the middle frame (55013) (55113) by means of the adjustment fitting (55005).

Mount the middle frame (55034) (55052) on the connecting frame (55006) using the bolt (55004), and then screw the handle (51259) and thread spindle onto the fitting on the middle frame (55034) (55052).

Mount the three point hitch (55033) (55050) on the middle frame (55034) (55052) using the bolt (55523) (55051).

Mount the wheel fittings (55032).

Finally mount the supporting leg (55525).

Fit the protection hoop (55015) and (55025) and the bracket (55010).

Mount the PTO shaft, and use the PTO fitting (55001).

Mount fitting (55017) with tines.

Note that there are left-hand and right-hand tines.

See also the mounting / spare parts drawings on the following pages.

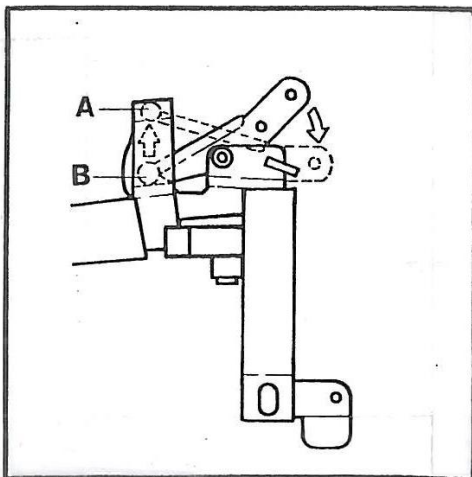

WORKING POSITION

The TI-4000 / TI-4000S combirake has two work settings for the three-point suspension:

A: Top bar handle in fixed position.

B: Top bar handle in floating position.

When driving on slopes and hillsides, etc., it is best to have the three-point suspension in the fixed position (A:)

The TI-4000 / TI-4000S combirake has four different working positions in all.

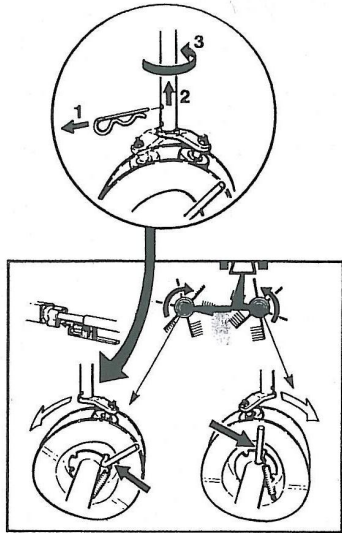

POS. 3

RAKING UP

For raking up, mount the fittings with the tines in the cam-track controlled fitting on the rotors. Adjust the wheel height by means of the wheel fitting under the rotors in the bottom or next-to-bottom hole. The machine must be adjusted for horizontal position using the handle located at the top of the middle frame. Do not allow the tines to touch the ground.

At the back the machine is equipped with handles for setting the working width. The selection of working width depends on the crop to be tedded and the desired swath width.

Under the rotors the cam-tracks are equipped with a handle which can be used to select one of three settings which determine how the tines deliver the material. The selection depends on the state of the crop and the desired swath width.

The machine is set to middle / ground position at the factory.

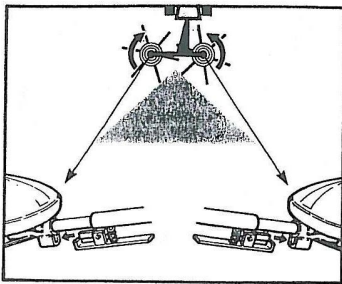

POS. 4

TEDDING

For tedding, mount the fitting with the tines in the fixed position on the rotors. Set the wheel height in the top hole in the fitting under the rotors, and set the machine by means of the handle located at the top of the middle frame so it leans forward. Do not allow the tines to touch the ground.

This working position gives a choice of three working widths which are selected by means of the handle as described in "Raking up".

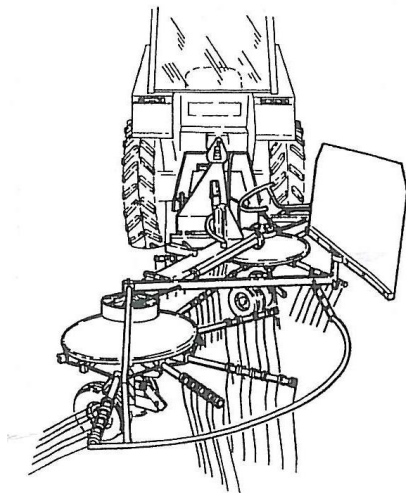

TRANSPORT POSITION

Change-over from working position to transport position is as follows: Lift the machine a little off the ground and set it to the intermediate working width by means of the adjustment fitting (55012). Release the retaining brackets (55010) and turn both protection braces behind the machine. Refit the retaining brackets in the second hole in the protection braces.

Release the machine from the Lock ratchet (55014) and the fitting (55003) from the middle frame. The machine then needs to be turned around until the fitting (55003) can be mounted as intended on the middle frame (55013) (55113). Remember to fit the locking clip (1210045). Move fittings with tines to the fittings which face towards the middle of the machine.

ORDERING SPARE PARTS

The spare part order must contain the following information:

- 1. Machine type.
- 2. Spare part number and description-possibly dimensions and number of parts.

LUBRICATION AND MAINTENANCE

Lubricate PTO shaft after every 10 hours of operation, and lubricate the indicated lubrication points as and when required.
Retighten bolts.

