



Twose Series Reach Arms

**TA320 & TA420**

Operation Manual

Publication 653

May 2016

# IMPORTANT VERIFICATION OF WARRANTY REGISTRATION



## DEALER WARRANTY INFORMATION & REGISTRATION VERIFICATION

It is imperative that the selling dealer registers this machine with McConnel Limited before delivery to the end user – failure to do so may affect the validity of the machine warranty.

To register machines go to the McConnel Limited web site at [www.mcconnel.com](http://www.mcconnel.com), log onto 'Dealer Inside' and select the 'Machine Registration button' which can be found in the Service Section of the site. Confirm to the customer that the machine has been registered in the section below.

Should you experience any problems registering a machine in this manner please contact the McConnel Service Department on 01584 875848.

### Registration Verification

Dealer Name: .....
Dealer Address: .....
Customer Name: .....
Date of Warranty Registration: ...../...../..... Dealer Signature: .....

### NOTE TO CUSTOMER / OWNER

*Please ensure that the above section above has been completed and signed by the selling dealer to verify that your machine has been registered with McConnel Limited.*

**IMPORTANT:** During the initial 'bedding in' period of a new machine it is the customer's responsibility to regularly inspect all nuts, bolts and hose connections for tightness and re-tighten if required. New hydraulic connections occasionally weep small amounts of oil as the seals and joints settle in – where this occurs it can be cured by re-tightening the connection – refer to torque settings chart below. The tasks stated above should be performed on an hourly basis during the first day of work and at least daily thereafter as part of the machines general maintenance procedure.

**CAUTION: DO NOT OVER TORQUE HYDRAULIC FITTINGS AND HOSES**

### TORQUE SETTINGS FOR HYDRAULIC FITTINGS

HYDRAULIC HOSE ENDS		
BSP	Setting	Metric
1/4"	18 Nm	19 mm
3/8"	31 Nm	22 mm
1/2"	49 Nm	27 mm
5/8"	60 Nm	30 mm
3/4"	80 Nm	32 mm
1"	125 Nm	41 mm
1.1/4"	190 Nm	50 mm
1.1/2"	250 Nm	55 mm
2"	420 Nm	70 mm

PORT ADAPTORS WITH BONDED SEALS		
BSP	Setting	Metric
1/4"	34 Nm	19 mm
3/8"	47 Nm	22 mm
1/2"	102 Nm	27 mm
5/8"	122 Nm	30 mm
3/4"	149 Nm	32 mm
1"	203 Nm	41 mm
1.1/4"	305 Nm	50 mm
1.1/2"	305 Nm	55 mm
2"	400 Nm	70 mm

# WARRANTY POLICY

## WARRANTY REGISTRATION

All machines must be registered, by the selling dealer with McConnel Ltd, before delivery to the end user. On receipt of the goods it is the buyer's responsibility to check that the Verification of Warranty Registration in the Operator's Manual has been completed by the selling dealer.

### 1. LIMITED WARRANTIES

- 1.01. *All machines supplied by McConnel Ltd are warranted to be free from defects in material and workmanship from the date of sale to the original purchaser for a period of 12 months, unless a different period is specified.*
- 1.02. *All spare parts supplied by McConnel Ltd and purchased by the end user are warranted to be free from defects in material and workmanship from the date of sale to the original purchaser for a period of 6 months. All parts warranty claims must be supported by a copy of the failed part invoice to the end user. We cannot consider claims for which sales invoices are not available.*
- 1.03. *The warranty offered by McConnel Ltd is limited to the making good by repair or replacement for the purchaser any part or parts found, upon examination at its factory, to be defective under normal use and service due to defects in material or workmanship. Returned parts must be complete and unexamined. Pack the component(s) carefully so that any transit damage is avoided. All ports on hydraulic items should be drained of oil and securely plugged to prevent seepage and foreign body ingress. Certain other components, electrical items for example, may require particular care when packing to avoid damage in transit.*
- 1.04. *This warranty does not extend to any product from which McConnel Ltd's serial number plate has been removed or altered.*
- 1.05. *This warranty does not apply to any part of the goods, which has been subjected to improper or abnormal use, negligence, alteration, modification, fitment of non-genuine parts, accident damage, or damage resulting from contact with overhead power lines, damage caused by foreign objects (e.g. stones, iron, material other than vegetation), failure due to lack of maintenance, use of incorrect oil or lubricants, contamination of the oil, or which has served its normal life. This warranty does not apply to any expendable items such as blades, belts, clutch linings, filter elements, flails, flap kits, skids, soil engaging parts, shields, guards, wear pads, pneumatic tyres or tracks.*
- 1.06. *Temporary repairs and consequential loss - i.e. oil, downtime and associated parts are specifically excluded from the warranty.*
- 1.07. *Warranty on hoses is limited to 12 months and does not include hoses which have suffered external damage. Only complete hoses may be returned under warranty, any which have been cut or repaired will be rejected.*
- 1.08. *Machines must be repaired immediately a problem arises. Continued use of the machine after a problem has occurred can result in further component failures, for which McConnel Ltd cannot be held liable, and may have safety implications.*
- 1.09. *If in exceptional circumstances a non McConnel Ltd part is used to effect a repair, warranty reimbursement will be at no more than McConnel Ltd's standard dealer cost for the genuine part.*
- 1.10. *Except as provided herein, no employee, agent, dealer or other person is authorised to give any warranties of any nature on behalf of McConnel Ltd.*
- 1.11. *For machine warranty periods in excess of 12 months the following additional exclusions shall apply:*
  - 1.11.1. *Hoses, exposed pipes and hydraulic tank breathers.*
  - 1.11.2. *Filters.*
  - 1.11.3. *Rubber mountings.*
  - 1.11.4. *External electric wiring.*
  - 1.11.5. *Bearings and seals.*

- 1.12. *All service work, particularly filter changes, must be carried out in accordance with the manufacturer's service schedule. Failure to comply will invalidate the warranty. In the event of a claim, proof of the service work being carried out may be required.*
- 1.13. *Repeat or additional repairs resulting from incorrect diagnosis or poor quality previous repair work are excluded from warranty.*

***NB Warranty cover will be invalid if any non-genuine parts have been fitted or used. Use of non-genuine parts may seriously affect the machine's performance and safety. McConnel Ltd cannot be held responsible for any failures or safety implications that arise due to the use of non-genuine parts.***

## **2. REMEDIES AND PROCEDURES**

- 2.01. *The warranty is not effective unless the Selling Dealer registers the machine, via the McConnel Ltd web site and confirms the registration to the purchaser by completing the confirmation form in the operator's manual.*
- 2.02. *Any fault must be reported to an authorised McConnel Ltd dealer as soon as it occurs. Continued use of a machine, after a fault has occurred, can result in further component failure for which McConnel Ltd cannot be held liable.*
- 2.03. *Repairs should be undertaken within two days of the failure. Claims submitted for repairs undertaken more than 2 weeks after a failure has occurred, or 2 days after the parts were supplied will be rejected, unless the delay has been authorised by McConnel Ltd. Please note that failure by the customer to release the machine for repair will not be accepted as a reason for delay in repair or submitting warranty claims.*
- 2.04. *All claims must be submitted, by an authorised McConnel Ltd Service Dealer, within 30 days of the date of repair.*
- 2.05. *Following examination of the claim and parts, McConnel Ltd will pay, at their discretion, for any valid claim the invoiced cost of any parts supplied by McConnel Ltd and appropriate labour and mileage allowances if applicable.*
- 2.06. *The submission of a claim is not a guarantee of payment.*
- 2.07. *Any decision reached by McConnel Ltd is final.*

## **3. LIMITATION OF LIABILITY**

- 3.01. *McConnel Ltd disclaims any express (except as set forth herein) and implied warranties with respect to the goods including, but not limited to, merchantability and fitness for a particular purpose.*
- 3.02. *McConnel Ltd makes no warranty as to the design, capability, capacity or suitability for use of the goods.*
- 3.03. *Except as provided herein, McConnel Ltd shall have no liability or responsibility to the purchaser or any other person or entity with respect to any liability, loss, or damage caused or alleged to be caused directly or indirectly by the goods including, but not limited to, any indirect, special, consequential, or incidental damages resulting from the use or operation of the goods or any breach of this warranty. Notwithstanding the above limitations and warranties, the manufacturer's liability hereunder for damages incurred by the purchaser or others shall not exceed the price of the goods.*
- 3.04. *No action arising out of any claimed breach of this warranty or transactions under this warranty may be brought more than one (1) year after the cause of the action has occurred.*

## **4. MISCELLANEOUS**

- 4.01. *McConnel Ltd may waive compliance with any of the terms of this limited warranty, but no waiver of any terms shall be deemed to be a waiver of any other term.*
- 4.02. *If any provision of this limited warranty shall violate any applicable law and is held to be unenforceable, then the invalidity of such provision shall not invalidate any other provisions herein.*
- 4.03. *Applicable law may provide rights and benefits to the purchaser in addition to those provided herein.*



# DECLARATION OF CONFORMITY

*Conforming to EU Machinery Directive 2006/42/EC*

We,

**McCONNEL LIMITED**, Temeside Works, Ludlow, Shropshire SY8 1JL, UK

*Hereby declare that:*

The Product; *Tractor Mounted Hedgecutter / Grass Mower*

Product Code; *TW32*

Serial No. & Date ..... Type .....

Manufactured in; *United Kingdom*

Complies with the required provisions of the Machinery Directive 2006/42/EC  
The machinery directive is supported by the following harmonized standards;

- BS EN ISO 12100 (2010) Safety of machinery – General principles for design – Risk assessment and risk reduction.
- BS EN 349 (1993) + A1 (2008) Safety of machinery - Minimum distances to avoid the entrapment with human body parts.
- BS EN 953 (1997) + A1 (2009) Safety of machinery - Guards general requirements for the design and construction of fixed and movable guards.
- BS EN 4413 (2010) Hydraulic fluid power. Safety requirements for systems and their components.

McCONNEL LIMITED operates an ISO 9001:2008 quality management system, certificate number: FM25970.

This system is continually assessed by the;

British Standards Institution (BSI), Beech House, Milton Keynes, MK14 6ES, UK  
BSI is accredited by UK Accreditation Service, accreditation number: UKAS 003.  
The EC declaration only applies if the machine stated above is used in accordance with the operating instructions.

Signed  ..... *Responsible Person*  
*CHRISTIAN DAVIES on behalf of McCONNEL LIMITED*

Status: *General Manager*

Date: *May 2016*



# DECLARATION OF CONFORMITY

*Conforming to EU Machinery Directive 2006/42/EC*

We,

**McCONNEL LIMITED**, Temeside Works, Ludlow, Shropshire SY8 1JL, UK

*Hereby declare that:*

The Product; *Hydraulic Arm Mounted Flail Head*

Product Code; *TWHD*

Serial No. & Date ..... Type .....

Manufactured in; *United Kingdom*

Complies with the required provisions of the Machinery Directive 2006/42/EC  
The machinery directive is supported by the following harmonized standards;

- BS EN ISO 12100 (2010) Safety of machinery – General principles for design – Risk assessment and risk reduction.
- BS EN 349 (1993) + A1 (2008) Safety of machinery - Minimum distances to avoid the entrapment with human body parts.
- BS EN 953 (1997) + A1 (2009) Safety of machinery - Guards general requirements for the design and construction of fixed and movable guards.
- BS EN 4413 (2010) Hydraulic fluid power. Safety requirements for systems and their components.

McCONNEL LIMITED operates an ISO 9001:2008 quality management system, certificate number: FM25970.

This system is continually assessed by the;

British Standards Institution (BSI), Beech House, Milton Keynes, MK14 6ES, UK  
BSI is accredited by UK Accreditation Service, accreditation number: UKAS 003.  
The EC declaration only applies if the machine stated above is used in accordance with the operating instructions.

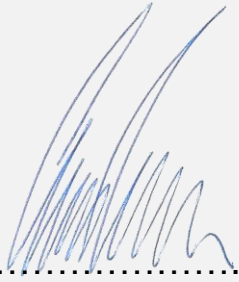
Signed  ..... *Responsible Person*  
*CHRISTIAN DAVIES on behalf of McCONNEL LIMITED*

Status: *General Manager*

Date: *May 2016*



# LIST OF CONTENTS

---

	<i>Page No.</i>
General Information	1
Features and Specifications	2
Safety Information	4
Tractor Requirements	8
Vehicle/Tractor Preparation	9
Closed Centre Conversion	10
Delivery & Pre-Attachment	11
Attachment to Tractor	12
Stabilizer Adjustment	14
PTO Driveshaft Installation	15
Fitting Operator Control Units	16
Hydraulic Oil	17
Flail Motor Hose Installation	18
Detachment	19
Rotor Operation	20
Cable Controls	21
Low Pressure Hydraulic Controls	23
Transport Position	24
Operation	25
Running Up Procedure	26
Reversing Rotation ( <i>Semi-Independent Machines</i> )	27
Operating Speeds	28
Breakaway Protection System	29
Angle Float Kit	29
Lift Float Kit	30
Hazards & Dangers	31
Overhead Power Lines	32
Hedge Cutting Procedure	33
General Maintenance	34
Hydraulic System	35
Hydraulic Hoses	36
PTO Shaft Maintenance	37





## GENERAL INFORMATION

---

Always read this manual before fitting or operating the machine – whenever any doubt exists contact your dealer or the McConnel Service Department for advice and assistance.

### **Use only Twose Classic Line Parts on Twose Classic Line Equipment and Machines**

**DEFINITIONS** – *The following definitions apply throughout this manual:*

#### WARNING

An operating procedure, technique etc., which –  
***can result in personal injury or loss of life if not observed carefully.***

#### CAUTION

An operating procedure, technique etc., which –  
***can result in damage to either machine or equipment if not observed carefully.***

#### NOTE

An operating procedure, technique etc., which is –  
***considered essential to emphasis.***

#### LEFT AND RIGHT HAND

This term is applicable to the machine when attached to the tractor and is viewed from the rear – this also applies to tractor references.

**Note:** The illustrations in this manual are for instructional purposes only and may on occasion not show some components in their entirety. In some instances an illustration may appear slightly different to that of your particular model but the general procedure will be the same. E&OE.

## MACHINE & DEALER INFORMATION

**Record the Serial Number of your machine on this page and always quote this number when ordering parts. Whenever information concerning the machine is requested remember also to state the make and model of tractor to which the machine is fitted.**

Machine Serial Number:

Installation Date:

Machine Model details:

Dealer Name:

Dealer Address:

Dealer Telephone No:

Dealer Email Address:

## FEATURES & SPECIFICATIONS

---

### All Models

- Three-point Linkage Mounting System
- Right or Left Hand Build Options
- Front Mount Build Options
- Low Power Requirement
- High Performance Hydraulic System
- Parallel Arm Geometry
- Hydraulic Safety Breakaway
- Operator Guard
- Storage Support Legs
- Choice of Attachments
- Head Angle Float Kit

### Additional Options

- Lift Float Kit





This machine has the potential to be extremely dangerous - in the wrong hands it can kill or maim; It is therefore imperative that both owner and operator of the machine reads and understands the following section to ensure they are fully aware of the dangers that do, or may exist, and their responsibilities surrounding the use and operation of the machine.

The operator of this machine is responsible not only for their own safety but equally for the safety of others who may come into the close proximity of the machine, as the owner you are responsible for both.

When the machine is not in use the cutting head should be lowered to rest on the ground. In the event of any fault being detected with the machine's operation it must be stopped immediately and not used again until the fault has been corrected by a qualified technician.

### **POTENTIAL SIGNIFICANT DANGERS ASSOCIATED WITH THE USE OF THIS MACHINE:**

- ▲ *Being hit by debris thrown by rotating components.*
- ▲ *Being hit by machine parts ejected through damage during use.*
- ▲ *Being caught on a rotating power take-off (PTO) shaft.*
- ▲ *Being caught in other moving parts i.e.: belts, pulleys and cutting heads.*
- ▲ *Electrocution from Overhead Power Lines (by contact with or 'flashover' from).*
- ▲ *Being hit by cutting heads or machine arms as they move.*
- ▲ *Becoming trapped between tractor and machine when hitching or unhitching.*
- ▲ *Tractor overbalancing when machine arm is extended.*
- ▲ *Injection of high-pressure oil from hydraulic hoses or couplings.*
- ▲ *Machine overbalancing when freestanding (out of use).*
- ▲ *Road traffic accidents due to collision or debris on the road.*

## **BEFORE USING THIS MACHINE YOU MUST:**

- ▲ *Ensure you read all sections of the operator handbook.*
- ▲ *Ensure the operator is, or has been, properly trained to use the machine.*
- ▲ *Ensure the operator has been issued with and reads the operator handbook.*
- ▲ *Ensure the operator understands and follows the instructions in operator handbook.*
- ▲ *Ensure the tractor front, rear and sides are fitted with metal mesh or polycarbonate guards of suitable size and strength to protect the operator against thrown debris or parts.*
- ▲ *Ensure tractor guards are fitted correctly, are undamaged and kept properly maintained.*
- ▲ *Ensure that all machine guards are in position, are undamaged, and are kept maintained in accordance with the manufacturer's recommendations.*
- ▲ *Ensure flails and their fixings are of a type recommended by the manufacturer, are securely attached and that none are missing or damaged.*
- ▲ *Ensure hydraulic pipes are carefully and correctly routed to avoid damage by chaffing, stretching or pinching and that they are held in place with the correct fittings.*
- ▲ *Always follow the manufacturer's instructions for attachment and removal of the machine from the tractor.*
- ▲ *Check that the machine fittings and couplings are in good condition.*
- ▲ *Ensure the tractor meets the minimum weight recommendations of the machine's manufacturer and that ballast is used as necessary.*
- ▲ *Always inspect the work area thoroughly before starting to note obstacles and remove wire, bottles, cans and other debris.*
- ▲ *Use clear suitably sized warning signs to alert others to the nature of the machine working within that area. Signs should be placed at both ends of the work site. (It is recommended that signs used are of a size and type specified by the Department of Transport and positioned in accordance with their, and the Local Highways Authority, guidelines).*
- ▲ *Ensure the operator is protected from noise. Ear defenders should be worn and tractor cab doors and windows must be kept closed. Machine controls should be routed through proprietary openings in the cab to enable all windows to be shut fully.*
- ▲ *Always work at a safe speed taking account of the conditions i.e.: terrain, highway proximity and obstacles around and above the machine. Extra special attention should be applied to Overhead Power Lines. Some of our machines are capable of reach in excess of 8 metres (26 feet) this means they have the potential to well exceed, by possibly 3 metres (9' 9"), the lowest legal minimum height of 5.2 metres from the ground for 11,000 and 33,000 volt power lines. It cannot be stressed enough the dangers that surround this capability, it is therefore vital that the operator is fully aware of the maximum height and reach of the machine, and that they are fully conversant with all aspects regarding the safe minimum distances that apply when working with machines in close proximity to Power Lines. (Further information on this subject can be obtained from the Health & Safety Executive or your Local Power Company).*

- ▲ *Always disengage the machine, kill the tractor engine, remove and pocket the key before dismounting for any reason.*
- ▲ *Always clear up all debris left at the work area, it may cause hazard to others.*
- ▲ *Always ensure when you remove your machine from the tractor that it is left in a safe and stable position using the stands and props provided and secured if necessary.*

#### **WHEN NOT TO USE THIS MACHINE:**

- ▲ *Never attempt to use this machine if you have not been trained to do so.*
- ▲ *Never use a machine until you have read and understood the operator handbook, are familiar with it, and practiced the controls.*
- ▲ *Never use a machine that is poorly maintained.*
- ▲ *Never use a machine if guards are missing or damaged.*
- ▲ *Never use a machine on which the hydraulic system shows signs of wear or damage.*
- ▲ *Never fit, or use, a machine on a tractor that does not meet the manufacturer's minimum specification level.*
- ▲ *Never use a machine fitted to a tractor that does not have suitable front, rear and side(s) cab guarding made of metal mesh or polycarbonate.*
- ▲ *Never use the machine if the tractor cab guarding is damaged, deteriorating or badly fitted.*
- ▲ *Never turn a machine cutting head to an angle that causes debris to be ejected towards the cab.*
- ▲ *Never start or continue to work a machine if people are nearby or approaching - Stop and wait until they are at a safe distance before continuing. WARNING: Some cutting heads may continue to 'freewheel' for up to 40 seconds after being stopped.*
- ▲ *Never attempt to use a machine on materials in excess of its capability.*
- ▲ *Never use a machine to perform a task it has not been designed to do.*
- ▲ *Never operate the tractor or machine controls from any position other than from the driving seat, especially whilst hitching or unhitching the machine.*
- ▲ *Never carry out maintenance of a machine or a tractor whilst the engine is running – the engine should be switched off, the key removed and pocketed.*
- ▲ *Never leave a machine unattended in a raised position – it should be lowered to the ground in a safe position on a level firm site.*
- ▲ *Never leave a tractor with the key in or the engine running.*
- ▲ *Never carry out maintenance on any part or component of a machine that is raised unless that part or component has been properly substantially braced or supported.*
- ▲ *Never attempt to detect a hydraulic leak with your hand – use a piece of cardboard.*
- ▲ *Never allow children near to, or play on, a tractor or machine under any circumstances.*

## ADDITIONAL SAFETY ADVICE

### Training

Operators need to be competent and fully capable of operating this machine in a safe and efficient way prior to attempting to use it in any public place. We advise therefore that the prospective operator make use of relevant training courses available such as those run by the Agricultural Training Board, Agricultural Colleges and Dealers.

### Working in Public Places

When working in public places such as roadsides, consideration should be paid to others in the vicinity. Stop the machine immediately when pedestrians, cyclists and horse riders etc. pass. Restart only when they are at a distance that causes no risk to their safety.

### Warning Signs

It is advisable that any working area be covered by suitable warning signs and statutory in public places. Signs should be highly visible and well placed in order to give clear advanced warning of the hazard. Contact the Department of Transport or your Local Highways Authority to obtain detailed information on this subject. The latter should be contacted prior to working on the public highway advising them of the time and location of the intended work asking what is required by way of signs and procedure. – *‘Non-authorized placement of road signs may create offences under the Highways Act’*.

### Suggested Warning Signs Required

*‘Road Works Ahead’ warning sign with a supplementary ‘Hedge Cutting’ plate. ‘For 1 mile’ or appropriate shorter distance may be added to the plate.*

*‘Road Narrows’ warning signs with supplementary ‘Single File Traffic’ plate.*

*White on blue ‘Keep Right’ (\*) arrow sign on rear of machine.*

*\* Note – this applies to UK Market machines where traffic passes to the right of a machine working in the same direction as the traffic flow. The direction, use and colour of the arrow sign will depend on the country of use and the Local Highway Authorities regulations in the locality.*

### Use of Warning Signs

- ▲ *On two-way roads one set of signs is needed facing traffic in each direction.*
- ▲ *Work should be within 1 mile of the signs.*
- ▲ *Work only when visibility is good and at times of low risk e.g. NOT during ‘rush-hour’.*
- ▲ *Vehicles should have an amber-flashing beacon.*
- ▲ *Ideally, vehicles should be conspicuously coloured.*
- ▲ *Debris should be removed from the road and path as soon as practicable, and at regular intervals, wearing high visibility clothing and before removing the hazard warning signs.*
- ▲ *Collect all road signs promptly when the job is completed.*

---

*Although the information stated here covers a wide range of safety subjects it is impossible to predict every eventuality that can occur under differing circumstances whilst operating this machine. No advice given here can replace ‘good common sense’ and ‘total awareness’ at all times, but will go a long way towards the safe use of your McConnel machine.*

---



## VEHICLE / TRACTOR REQUIREMENTS

---

### **Minimum Tractor Weights** *(including ballast weights if necessary)*

TA320 Models – 1300kg

TA420 Models – 2000kg

### **Minimum HP Requirements**

25HP for TA320 & TA420 Models with Cutterbar.

30HP for TA320 & TA420 Models with Flailhead.

### **Linkage Type**

Category 1 or Category 2.

### **Linkage Isolation**

A linkage isolation facility is necessary for semi-independent models.

### **Check Chains/Stabilizers**

Check Chains and/or Stabilizer Bars must be fitted and tightened.

### **Tractor Relief Valve**

On Semi-independent models only, tractor relief valve must be set above 160Bar (2300 PSI).

### **Tractor Hydraulic Flow Rate**

Hydraulic flow rates are not crucial for semi-independent models.

### **PTO Shaft**

The tractor must be equipped with a 'live drive' independent PTO to allow the flailhead to continue to operate when tractor forward motion is halted.

## VEHICLE / TRACTOR PREPARATION

**Guarding:** We recommend vehicles are fitted with cabs using safety glass windows and protective guarding when used with our machines. Fit Operator Guard (*part no. 7313324*) using the hooks provided. Shape mesh to cover all vulnerable areas. Remember the driver must be looking through mesh and/or polycarbonate glazing when viewing the flail head in any

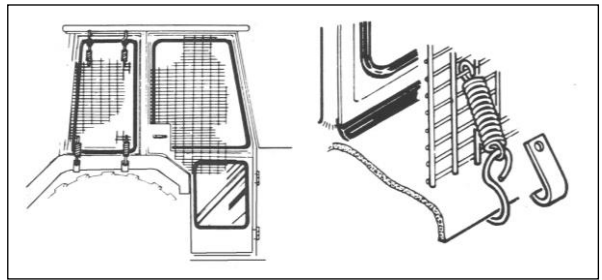

working position - unless the vehicle/ cab manufacturer can demonstrate that the penetration resistance is equivalent to, or higher than, that provided by mesh/polycarbonate glazing. If the tractor has a roll bar only, a frame must be made to carry both mesh and polycarbonate glazing. The operator should also use personal protective equipment to reduce the risk of serious injury such as; eye protection (mesh visor to EN1731 or safety glasses to EN166), hearing protection to EN352, safety helmet to EN297, gloves, filter mask and high visibility clothing.

**Vehicle Ballast:** It is imperative when attaching 'third-party' equipment to a tractor that the maximum possible stability of the machine and tractor combination is achieved – this can be accomplished by the utilisation of 'ballast' in order to counter-balance the additional equipment added.

**Front weights** may be required to place 15% of total outfit weight on the front axle for stable transport on the road and to reduce 'crabbing' due to drag of the cutting unit when working on the ground.

Rear weights may be required to maintain a reasonable amount of rear axle load on the opposite wheel from the arms when in work; for normal off-ground work i.e. hedge cutting this should be 20% of rear axle weight or more for adequate control, and for ground work i.e. verge mowing with experienced operators, this can be reduced to 10%.

All factors must be addressed in order to match the type and nature of the equipment added to the circumstances under which it will be used – in the instance of hedgecutters it must be remembered that the machine's centre of gravity during work will be constantly moving and will differ from that during transport mode, therefore balance becomes critical.

### Factors that effect stability

- *Centre of gravity of the tractor/machine combination.*
- *Geometric conditions, e.g. position of the cutting head and ballast.*
- *Weight, track width and wheelbase of the tractor.*
- *Acceleration, braking, turning and the relative position of the cutting head during these operations.*
- *Ground conditions, e.g. slope, grip, load capability of the soil/surface.*
- *Rigidity of implement mounting.*

### Suggestions to increase stability:

- *Increasing rear wheel track; a tractor with a wider wheel track is more stable.*
- *Ballasting the wheel; it is preferable to use external weights but liquid can be added to around 75% of the tyre volume – water with anti-freeze or the heavier Calcium Chloride alternative can be used.*
- *Addition of weights – care should be taken in selecting the location of the weights to ensure they are added to a position that offers the greatest advantage.*
- *Front axle locking; a ram can be used to 'lock' the front axle in work only – locking the axle moves the 'balance line' and can be used to transfer weight to the front axle from the rear (check with tractor manufacturer).*

**NOTE;** The advice above is offered as a guide for stability only and is not a guide to tractor strength - it is therefore recommended that you consult your tractor manufacturer or local dealer to obtain specific advice on this subject, additionally advice should be sought from a tyre specialist with regard to tyre pressures and ratings suitable for the type and nature of the machine you intend to fit.

## CLOSED CENTRE CONVERSION KIT – Semi-Independent models only

### Closed Centre Conversion Kit 8130059

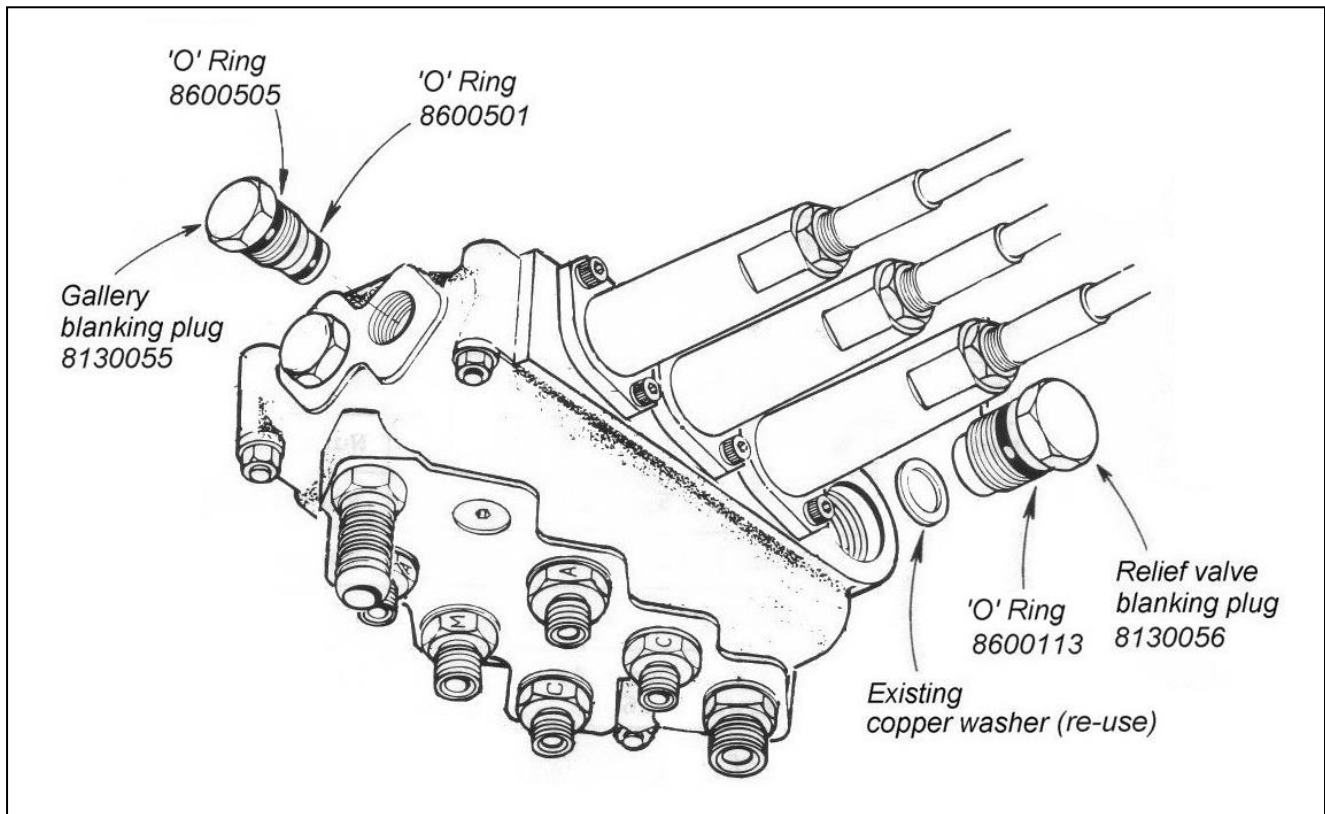

The Control Valve Conversion Kit (*Part No. 8130059*) consists of a relief valve blanking plug which should be installed in place of the existing relief valve, and a pressure gallery blanking plug which is installed in place of the standard blanking plug at the valve outlet end next to the lift ram gland connection. Take care when extracting the relief valve not to damage the copper sealing washer as this needs to be re-used.

**Note:** When working in this mode the tractor's pressure control valve must not exceed 170Bar (2500 PSI).

## DELIVERY & PRE-ATTACHMENT (Dealer Reference)

---

### Delivery

The machine will be delivered in a partially dismantled condition secured with transport straps and banding. Select a firm level site on which to place the machine before removing the straps, banding and other loose items.

### Handling the Machine

Handling of the machine should always be performed using suitable overhead lifting equipment with a minimum safe lifting capacity over and above the maximum weight of the machine. Always ensure the machine is balanced during the lifting procedure and that all bystanders are kept well clear of the raised machine.

### Lifting Points

To ensure even weight distribution when handling the machine it should be lifted using the sling eye and sling shackle attached to the machine at the lifting points as illustrated below. The lifting sling or chain should be adjusted to ensure the machine is level and balanced when raised clear of the ground.

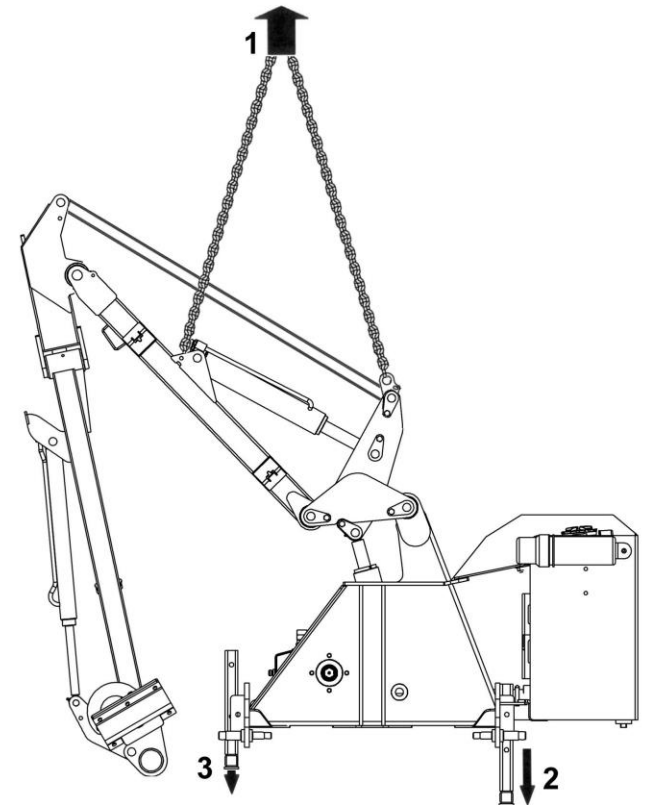

### Stand Legs

Raise the machine and lower the stand legs - secure the legs in the required position using pins and locking pins. Carefully lower the machine back onto the ground and check the machine is stable before attempting to unhitch the lifting gear.

# ATTACHMENT TO TRACTOR

Attachment to the tractor should be performed on a firm level site.

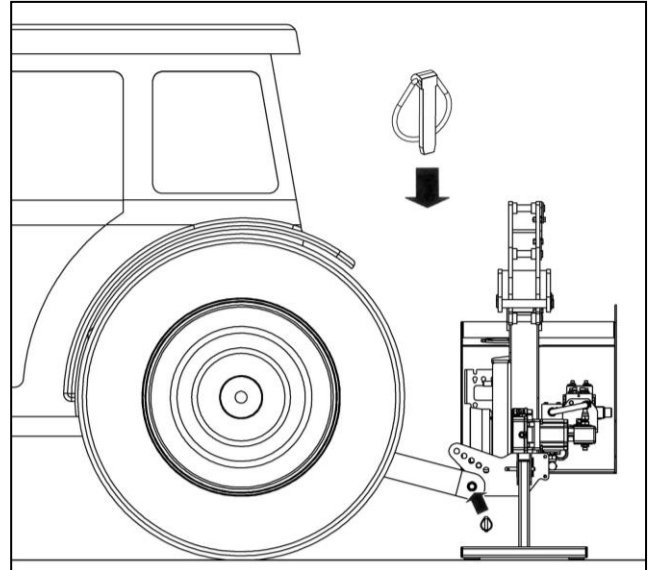
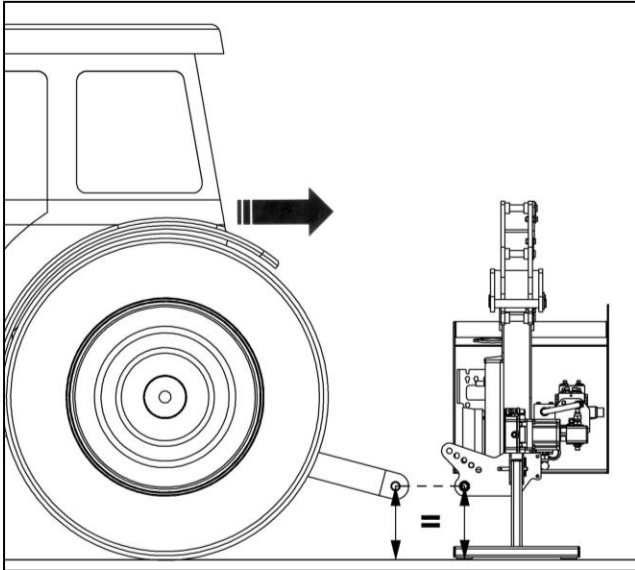

Reverse tractor squarely to the machine with lower links in line with machine attachment points, fit and secure with lynch pins.

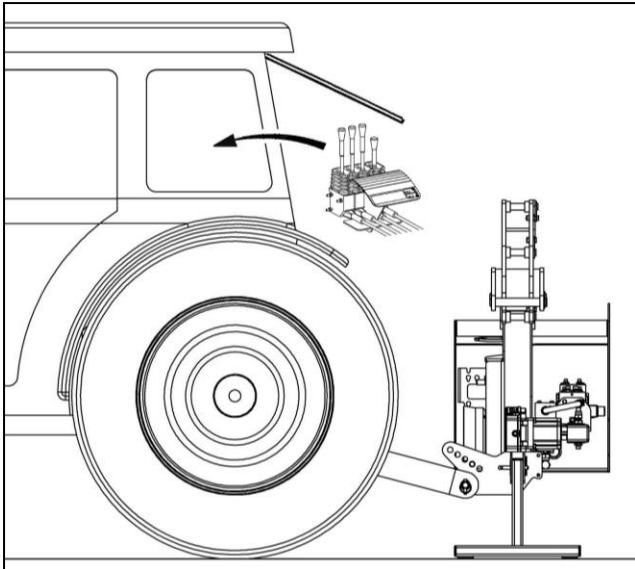

Fit machine operation controls in the tractor cab.  
On SI Models; Connect supply & return hoses to the tractor.

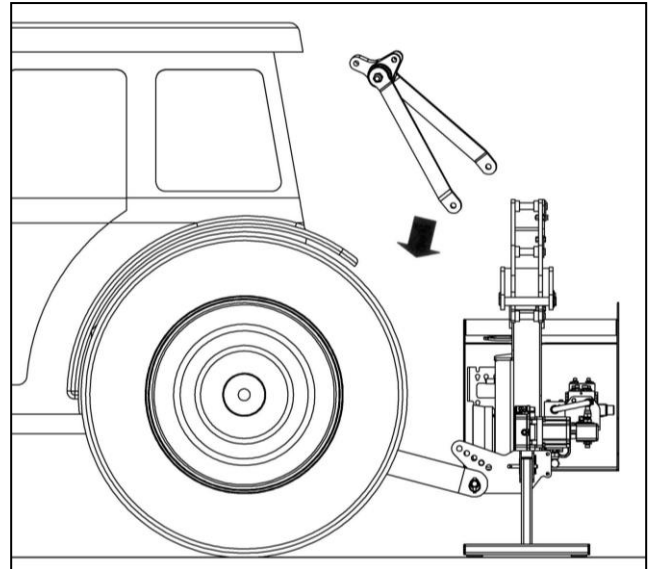

Offer stabilizer to tractor and mainframe – adjust to achieve optimum position (*refer to stabilizer adjustment page*).

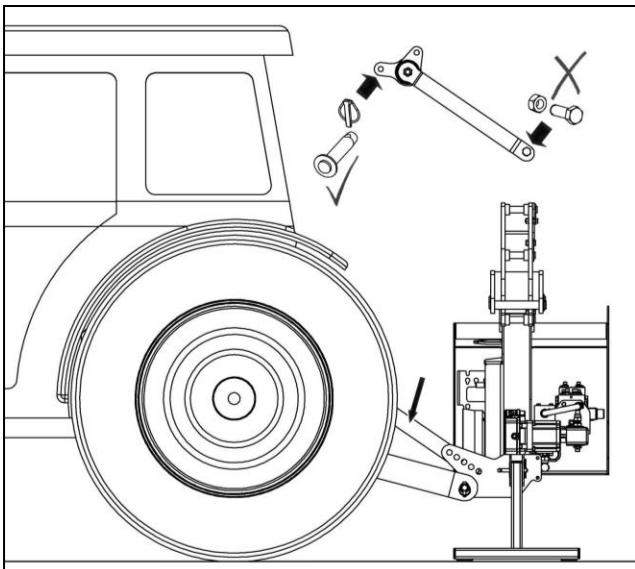

Secure stabilizer to tractor – do not secure to mainframe yet.

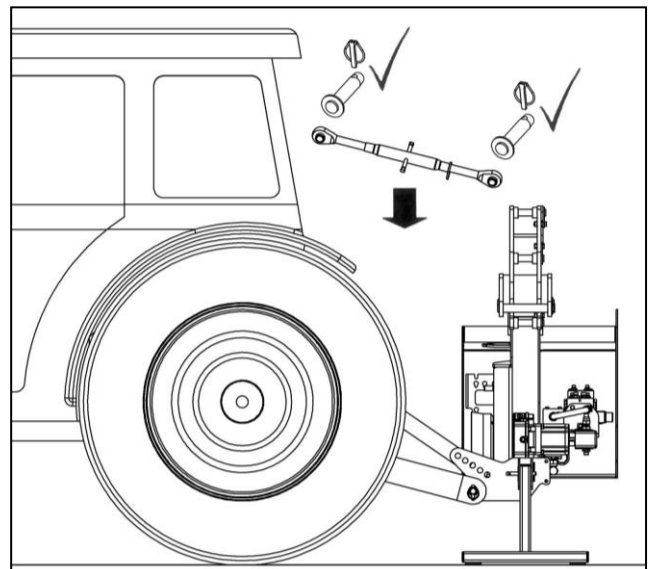

Fit top link between tractor and machine – secure in position.

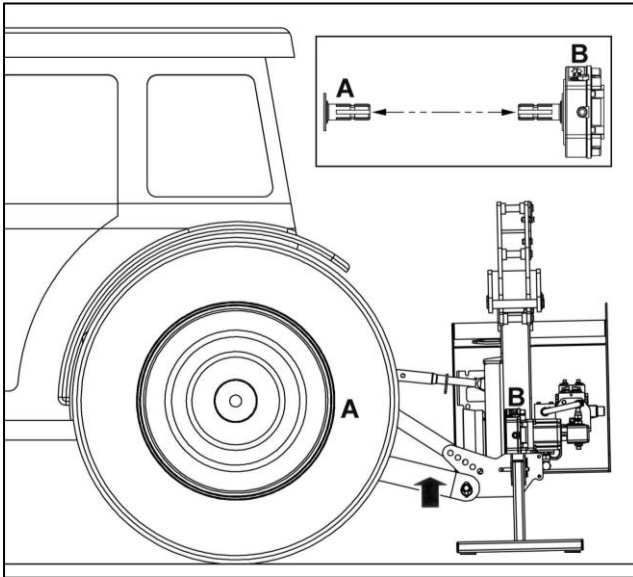

Raise machine on linkage until tractor's PTO (A) and gearbox stub shaft (B) are aligned as near as possible. Secure stabilizer to the machine lower mainframe with nuts and bolts supplied - selecting a suitable hole position that will retain the alignment.

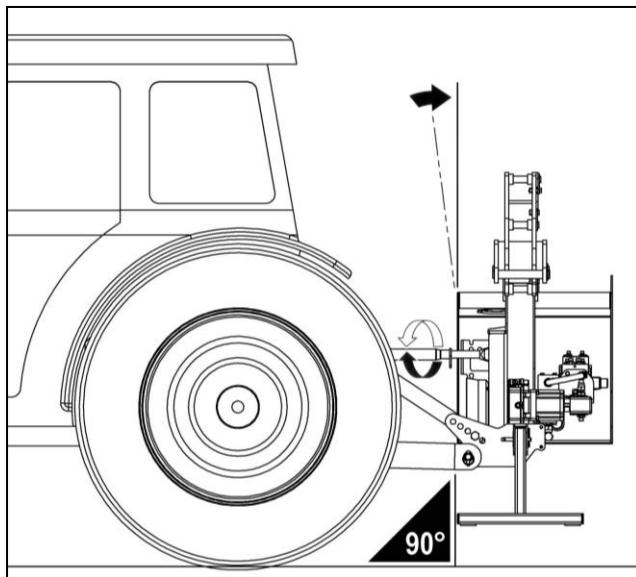
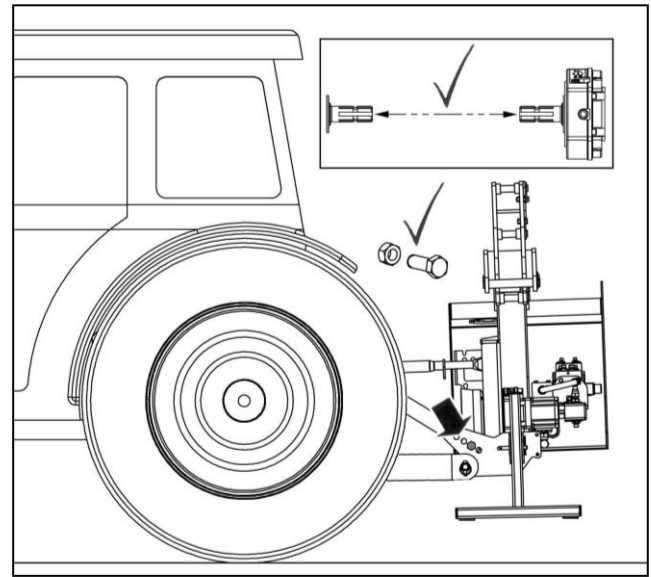

Lower tractor linkage until machine's weight is supported by the yoke - adjust the top link to place the machine vertical.

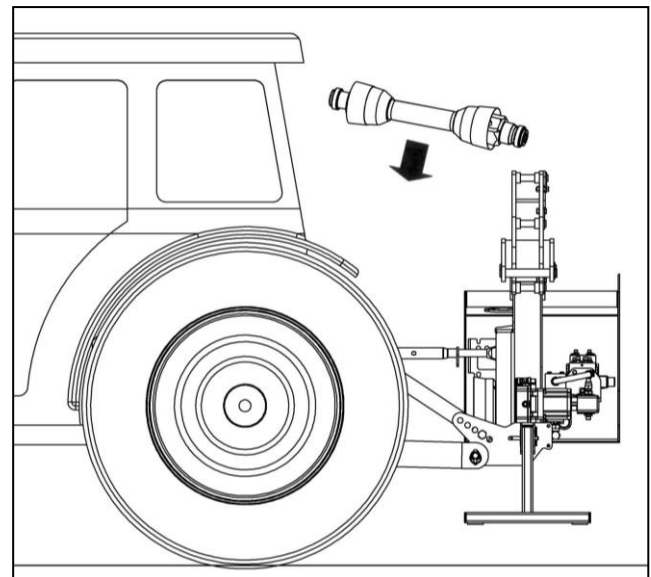

Measure and fit the PTO shaft - refer to the specific PTO installation page for information on measuring a PTO shaft.

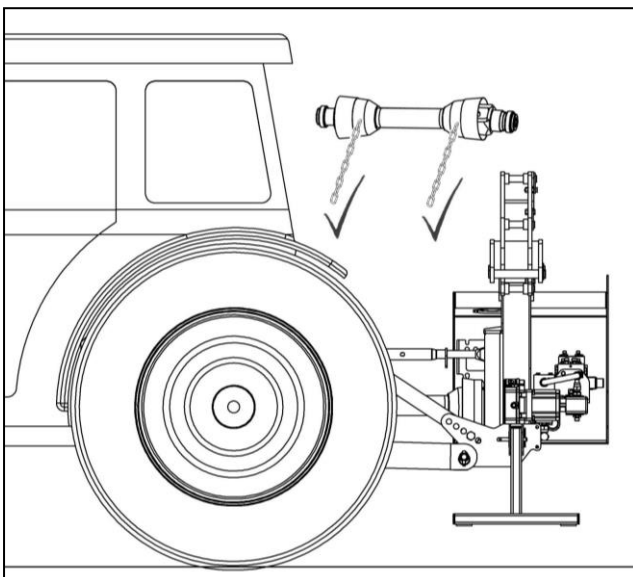

Fit torque chains from PTO guards to suitable locations on the tractor and/or machine to stop the guards from rotating.

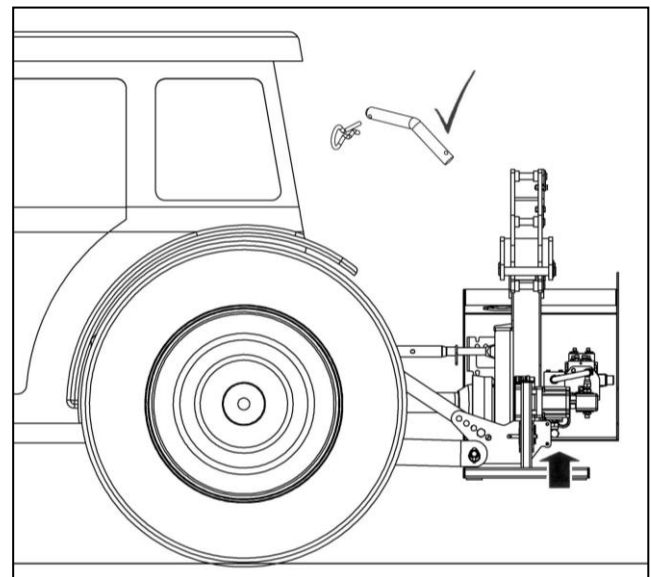

Raise stand legs into the transport and work position - secure with pins and R clips.

## STABILIZER ADJUSTMENT

For ease and precision of fitment the stabilizer supplied with the machine features an incremental notched positioning system that allows for both simpler adjustment and precise attachment over a wider range of applications.

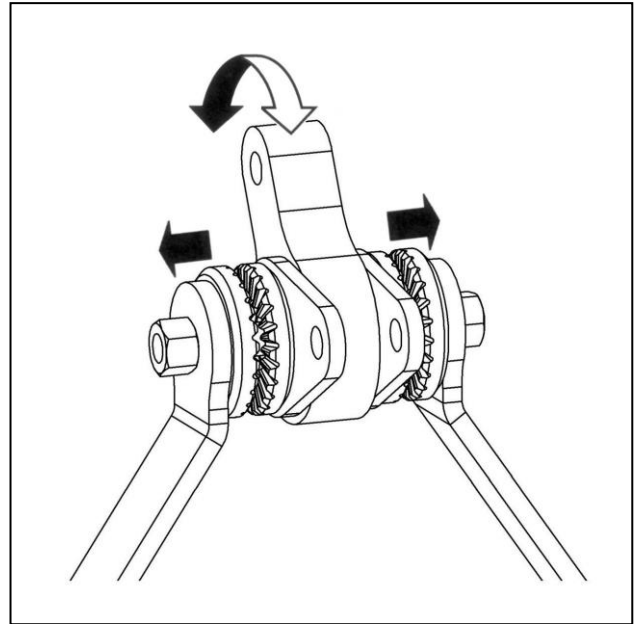
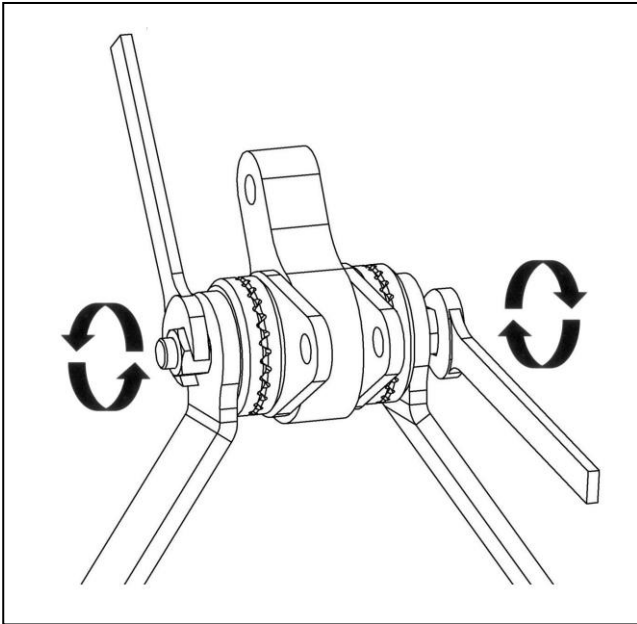

Loosen retaining nut and bolt. Pull stabilizer arms outwards to free stabilizer head and swivel to required position.

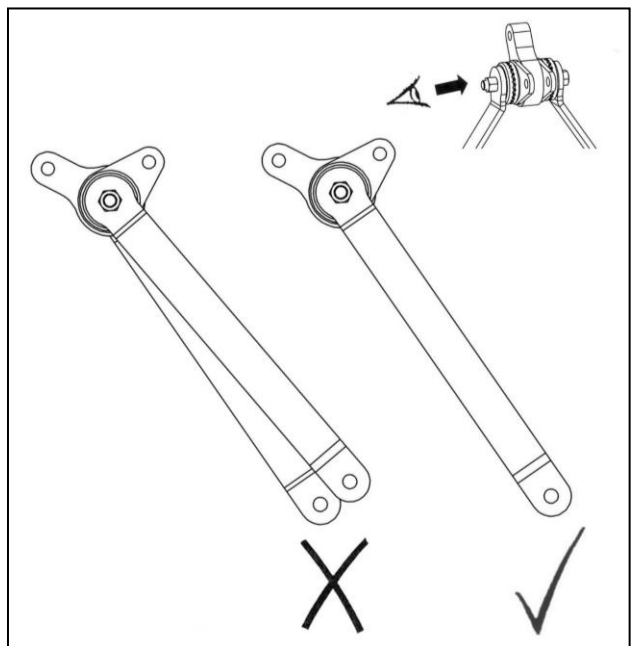
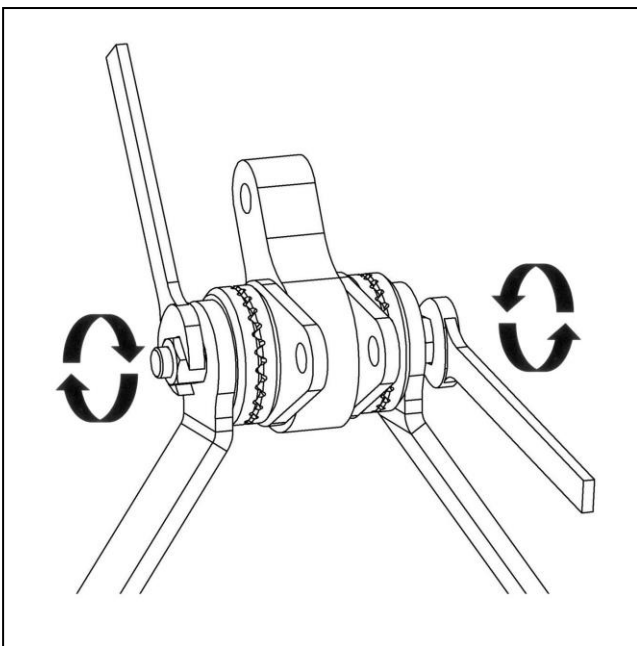

Push stabilizer arms inwards to re-engage notches and tighten nut and bolt to secure. Ensure that stabilizer arms are parallel when viewed from the side.

## PTO DRIVESHAFT INSTALLATION

The PTO driveshaft attaches between the tractor and the machine gearbox to transfer the power required to run and operate the machine – it is important to achieve the correct shaft length to avoid risk of it ‘bottoming out’ when raising or lowering the machine.

The procedure for measuring and cutting the shaft is as follows:

### Measuring the PTO Shaft

With the machine attached to the tractor in the working position measure the horizontal distance ‘A’ from the tractor’s PTO to the input shaft on the machine’s gearbox and subtract 75mm (3”) – *this figure is the required shaft length.*

Place the fully closed PTO shaft on the ground and measure its overall length, if the shaft is shorter than the required length you can use it without the need to shorten - *providing it allows for a minimum 150mm (6”) overlap when fitted.*

If the shaft is longer subtract the required shaft length plus an additional 75mm (3”) - *the resulting figure is the excess length that will need to be removed from each half of the shaft.*

### Cutting the PTO Shaft

Separate the two halves and using the measurement obtained above shorten both the plastic guarding and the inner steel profile tubes of each shaft by this same amount. De-burr the cut tubes with a file to remove rough or sharp edges and thoroughly clean to remove swarf before greasing, assembling and fitting the shaft.

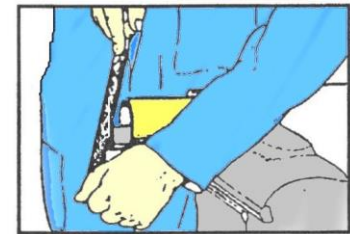
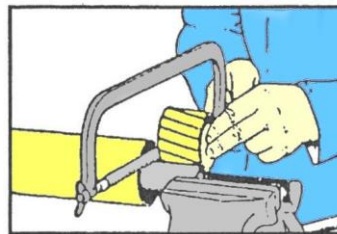
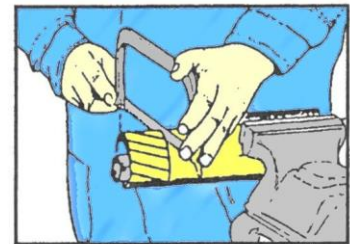
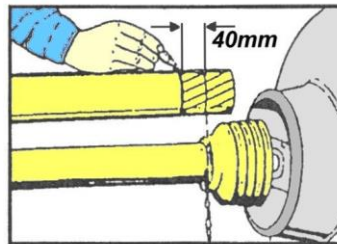
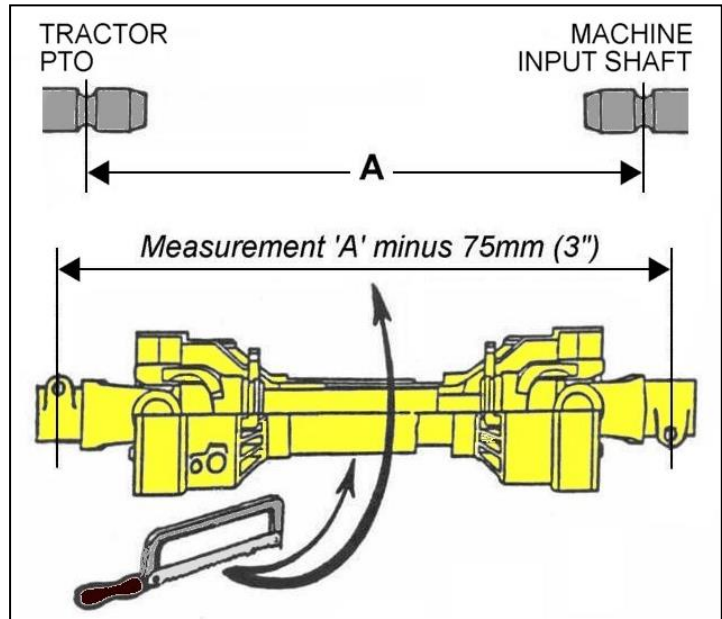

NOTE: For subsequent use with different tractors the shaft should be measured again to check suitability – *there must be a minimum shaft overlap of 150mm (6”).*

### Maintenance

To increase the working life of the PTO shaft it should be periodically checked, cleaned and lubricated – *refer to the PTO maintenance section for further details on this subject.*



## FITTING OPERATOR CONTROL UNITS

---

Fitment of the operator controls in the tractor cab will vary depending on the particular model or specification of machine – the information below lists the differing methods of fitment for the various types of controls available.

NOTE: Electric control units work within the range of 12v-16v DC and will require a minimum power supply of 12v DC.

### **Cable Controls**

Cable control units are provided with, and attached to, a mounting bracket – the bracket should be securely fixed to the internal mud wing or cab cladding in a suitable convenient location that offers ease of use without interfering with normal tractor operation.

In deciding the final position of the control unit bear in mind the location of the cable run – make sure the minimum acceptable cable bend radii of 8” (200mm) is not exceeded.

Ensure during fitting that no structural member of the tractor cab or roll bar is drilled or damaged.

The cable rotor control valve lever on cable controlled machines will be assembled as a component part of the main bank of controls and therefore shares the same mounting bracket.

On electric machines with cable operated rotor control valve the lever will be supplied as a ‘standalone’ unit with its own individual mounting bracket – this should be fitted in the same manner as above adopting the same precautions pertaining to attachment and cable runs.

### **Electric Controls**

Depending on the particular type of control, electric units are supplied either with a mounting bracket or a mounting pillar which should be bolted to the internal mud wing or cab cladding in a suitable convenient location that offers ease of use without interfering with normal tractor operation. Mounting pillars can be bent or twisted to achieve a comfortable working position. Ensure during fitting that no structural member of the tractor cab or roll bar is drilled or damaged.

The power supply cable should be connected directly to the tractors battery - do not use cigarette lighter type connections as these prove to be sporadic and unreliable for control applications. Control units are 12 volt DC operated; the brown lead is positive (+) and the blue lead is negative (-).

## HYDRAULIC OIL

### Hydraulic Oil Reservoir

Fill the tank with oil selected from the chart below or a good quality equivalent to a point where the level is between the minimum and maximum marks on the tank gauge. When the machine is initially run the level will drop as the oil is drawn into the circuit - *top back up* as required to the correct level on the gauge.

Always use clean receptacles when handling and transferring oil to avoid moisture or dirt contamination that can damage components and/or reduce machine performance.

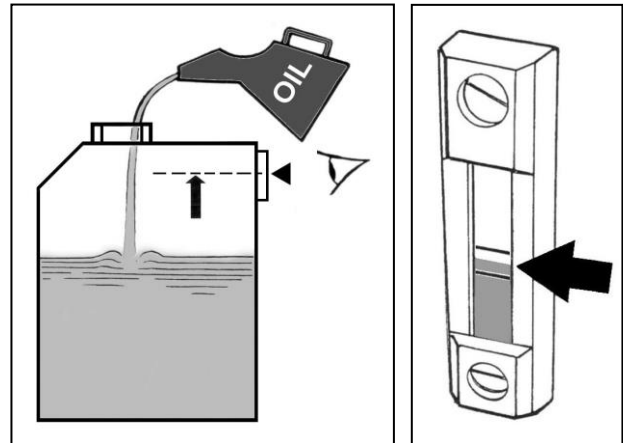

**NOTE:** Refer to the maintenance section for further information on the subject of hydraulic oil and system filtration.

### Reservoir Capacity

The oil tank capacity of the machine is approximately **80 Litres**.

### Recommended Hydraulic Oils

For initial filling of the oil reservoir, periodic oil changes and replenishment purposes the following hydraulic oils, or a good quality equivalent are recommended.

**NOTE:** Only use oils that are ISO 18/13 or cleaner.

Manufacturer	Cold or Temperate Climate	Hot Climate
<b>BP</b>	Bartran 46 Energol HLP-HM 46	Bartran 68 Energol HLP-HM 68
<b>CASTROL</b>	Hyspin AWH-M 46	Hyspin AWH-M 68
<b>COMMA</b>	Hydraulic Oil LIC 15	Hydraulic Oil LIC 20
<b>ELF</b>	Hydrelf HV 46 Hydrelf XV 46	Hydrelf HV 68
<b>ESSO</b>	Univis N 46	Univis N 68
<b>FUCHS</b> (UK/Non UK markets*)	Renolin 46 Renolin HVZ 46 Renolin CL46/B15* Renolin AF46/ZAF46B*	Renolin 68 Renolin HVZ 68 Renolin CL68/B20* Renolin AF68/ZAF68B*
<b>GREENWAY</b>	Excelpower HY 68	Excelpower HY 68
<b>MILLERS</b>	Millmax 46 Millmax HV 46	Millmax 68 Millmax HV 68
<b>MORRIS</b>	Liquimatic 5 Liquimatic HV 46 Triad 46	Liquimatic 6 Liquimatic HV 68 Triad 68
<b>SHELL</b>	Tellus 46 Tellus T46	Tellus 68 Tellus T68
<b>TEXACO</b>	Rando HD 46 Rando HDZ 46	Rando HD 68 Rando HDZ 68
<b>TOTAL</b>	Equivis ZS 46	Equivis ZS 68

# FLAIL MOTOR HOSE INSTALLATION

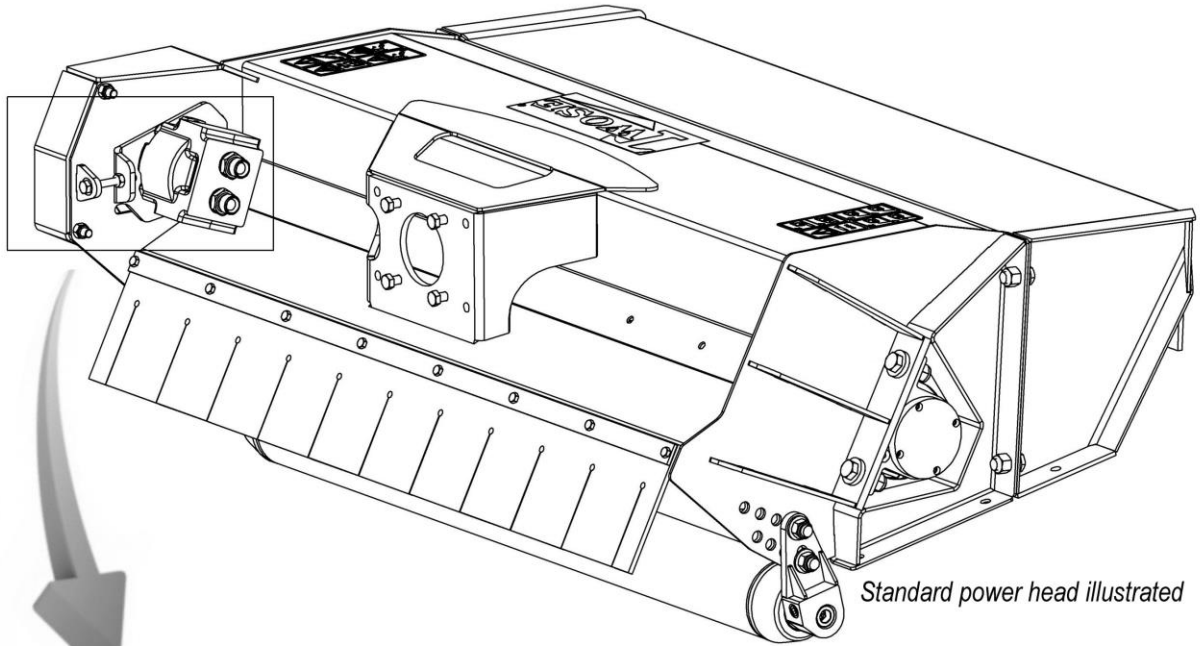

P = Pressure  
R = Return

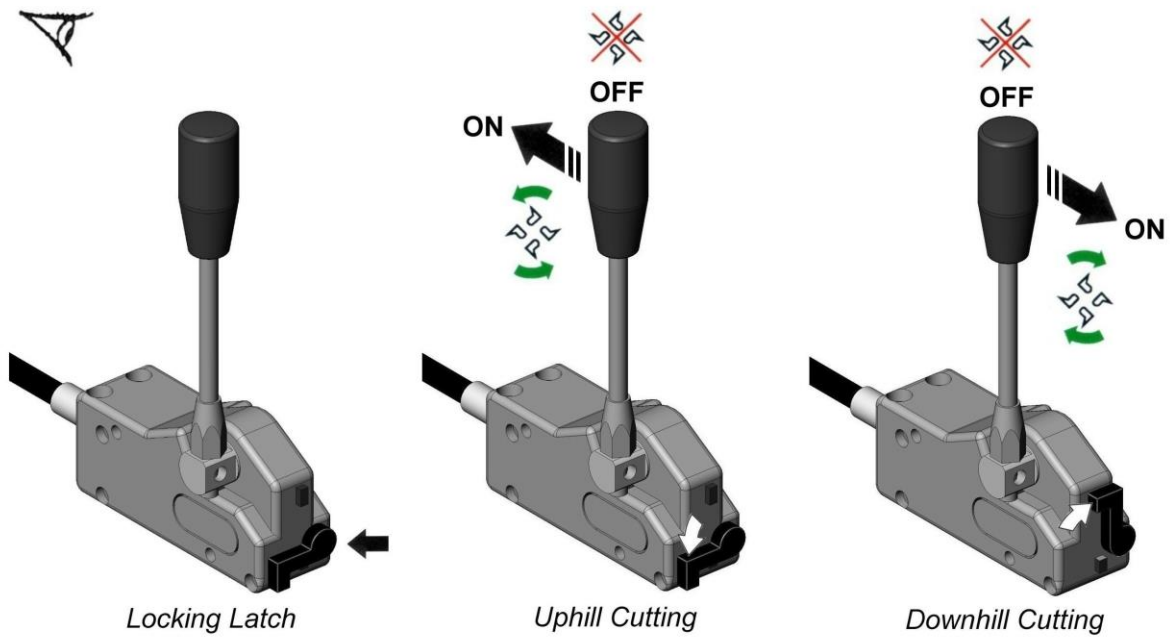
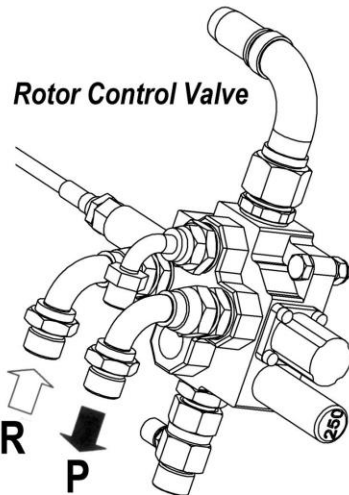
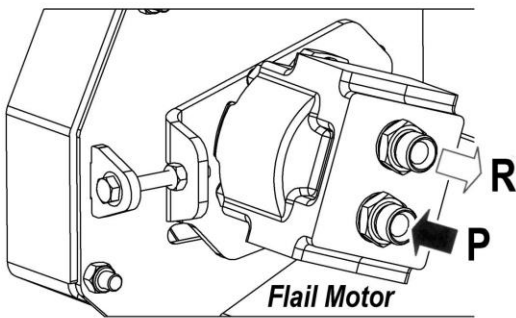



### **DANGER!**

**Read carefully before attempting to detach the machine from the tractor.**

### **WARNING!**

**Do not operate quadrant lever or machine controls through the rear cab window whilst standing on or amongst linkage components – Always seek assistance.**

### **Detachment Procedure**

Select a firm level site on which to park the machine.

- Remove stand legs from their stowage location and fit in their parking position – secure in position with pins and 'R' clips.
- Lower machine to rest on the stand legs.

**Ensure lift float is turned off (*where applicable*).**

- Raise machine on tractor linkage enough only to take the weight off the stabiliser.
- Ensure arm is in the rear position, place flailhead on the ground at half reach – push down slightly to relieve the load on the top link.
- Stop tractor engine.
- Disengage PTO and remove from tractor.
- Slacken stabiliser bars/check chains as applicable.
- Disconnect controls and/or control lines from the tractor cab and stow neatly on the machine clear of the ground.
- Disconnect stabiliser from tractors top hitch point.
- Remove draft link pins.
- Slowly and carefully drive the tractor away from the machine.

### **Storage**

If the machine is to be left standing for an extended period of time, lightly coat the exposed portions of the ram rods with grease. Subsequently, this grease should be wiped off before the rams are next moved.

Wherever possible storage of the machine should ideally be in a clean dry location, if the machine has to be stored outside tie a piece of tarpaulin or canvas over the control assembly, do not use plastic bags as these can lead to rapid corrosion of the unit.

## ROTOR OPERATION

### DANGER - VERY IMPORTANT

It is very important that motor spool and motor spool control lever works in one direction only - From centre (OFF) position to selected (ON) 'rotor cut' direction position – permitting the rotor one direction of cut and the 'OFF' setting only. This eliminates the chance of going from 'cut-up' to 'cut-down' in one movement of controls and blowing the system. Only by altering LOCK-LEVER setting can direction of control lever be changed.

### WARNING!

**DANGER - Never change direction of rotor cut whilst rotor is still turning.**

**DANGER – Always allow rotor to stop spinning completely before changing cut rotation direction.**

### Rotor Control Operation

The rotor control lever operates the rotor 'on' and 'off' function for both uphill and downhill cutting - the specific cutting direction is dictated by the position of the locking latch on the front of the cable control head unit, with the latch in the vertical position the lever can be moved from its centre 'off' position to the forwards 'on' position for uphill cutting direction. With the latch in the horizontal position the lever can be moved from its centre 'off' position to the backwards 'on' position for downhill cutting direction. The rotor is off when the control lever is in the central position – see *illustration below*.

**WARNING: When switching off a rotor it will continue to 'freewheel' before stopping - in some cases this can be up to 40 seconds or more. Never approach a machine whilst the rotor is running.**

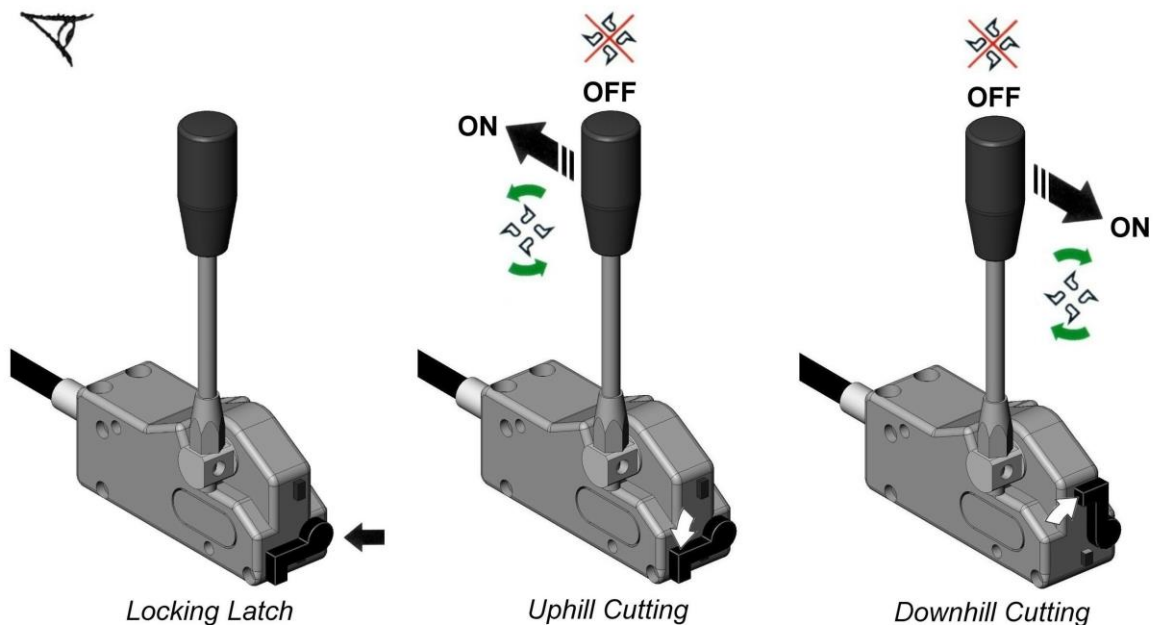

**ROTOR CUT DIRECTION MUST NEVER BE CHANGED IN ONE MOVEMENT**

# CABLE CONTROLS

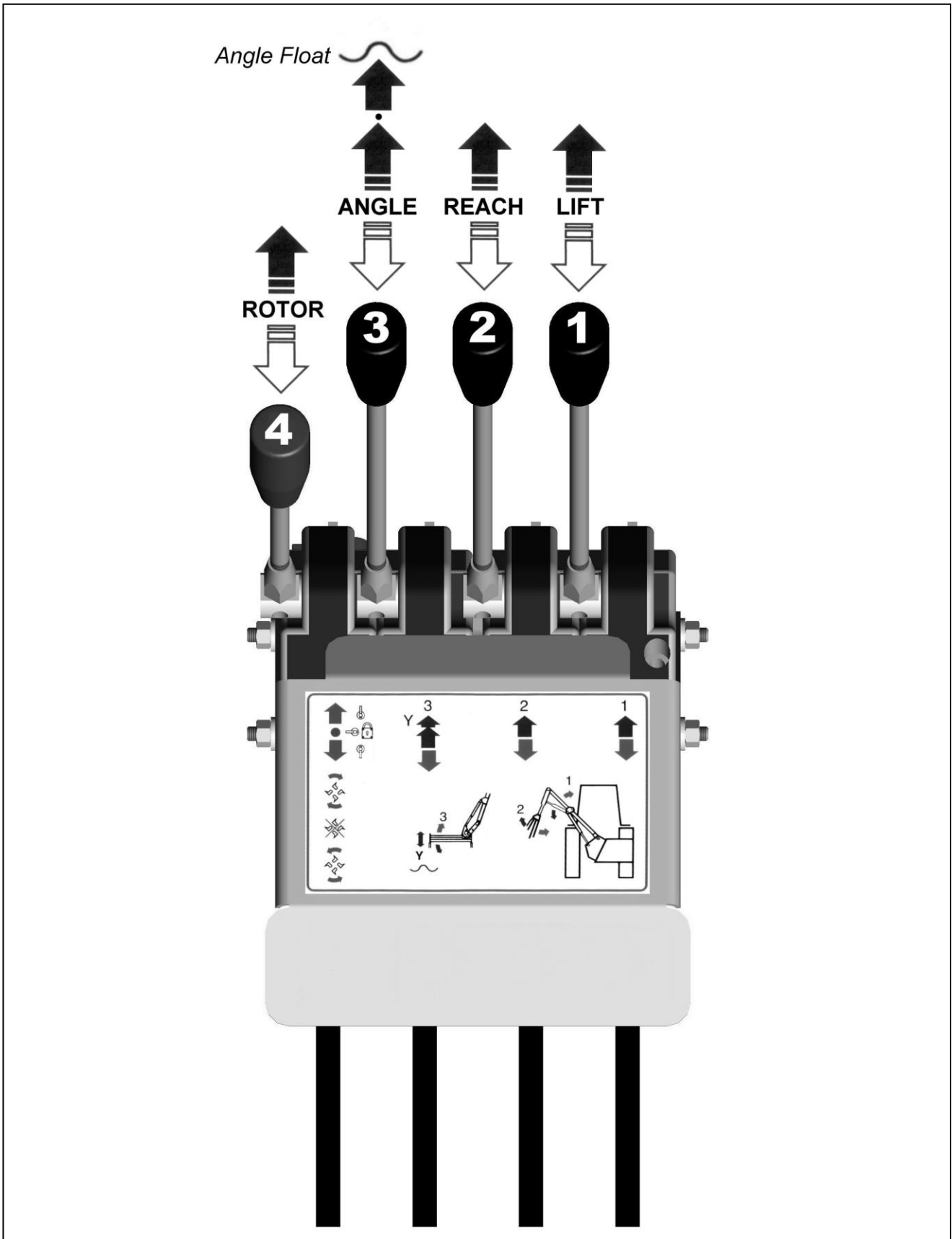

# CABLE CONTROLS – LEVER FUNCTIONS

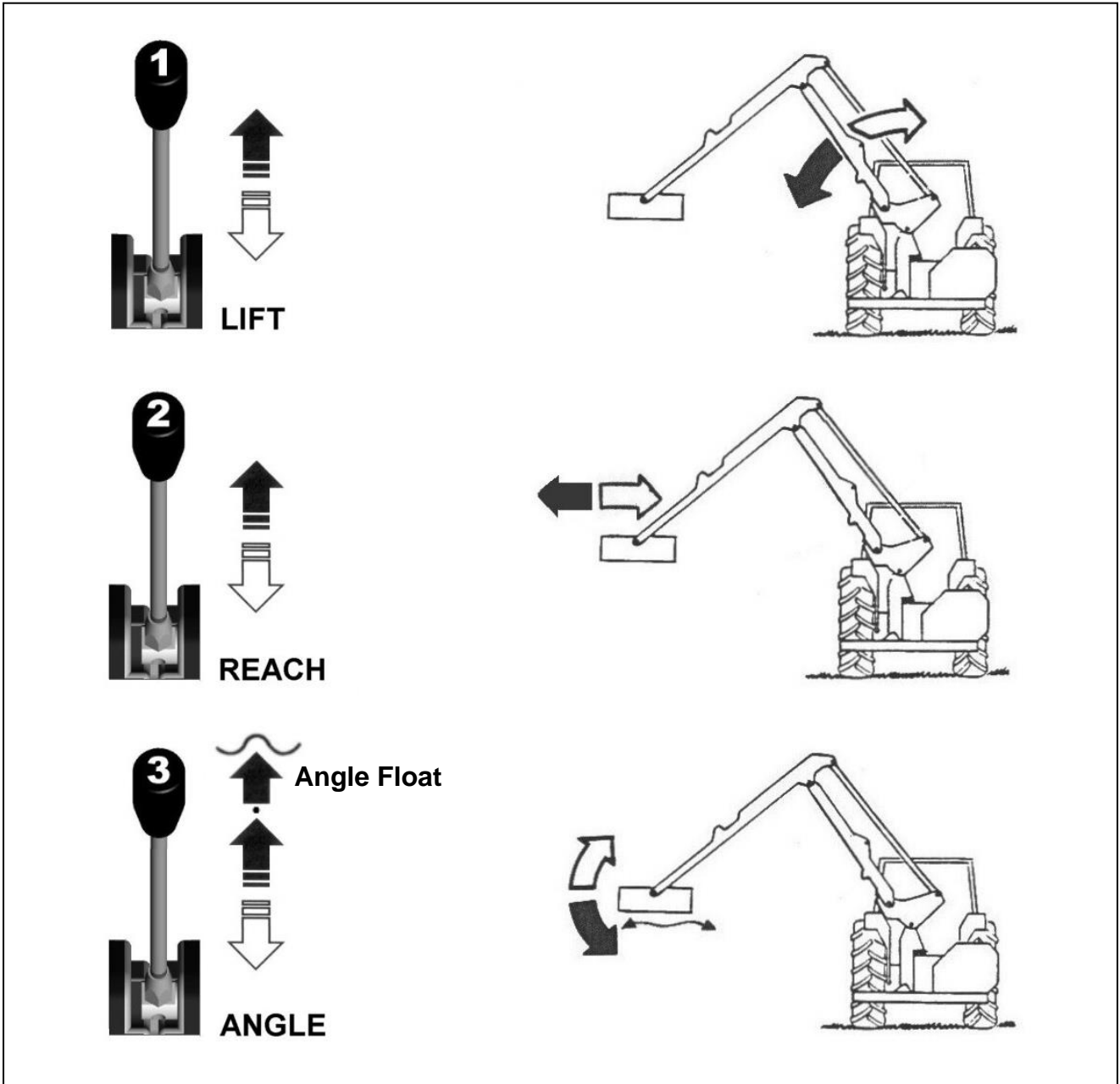

# LOW PRESSURE CONTROLS – Operation and Functions (Refer to diagrams)

**Power ON** – Connect Power Plug to battery.

**Power OFF** – Disconnect power from hedgecutter to tractor.

## Lever Functions

1. **Lever** - Movement of the lever in a 'Forward' and 'Backward' direction operates the Main Arm:  
**Forwards** – Lowers the Main Arm.  
**Backwards** – Raises the Main Arm.

2. **Lever** - Movement of the lever in a 'Sideways' direction operates the Dipper Arm:  
**Left** – Moves Dipper Arm away from the operator.  
**Right** – Moves Dipper Arm towards the operator.

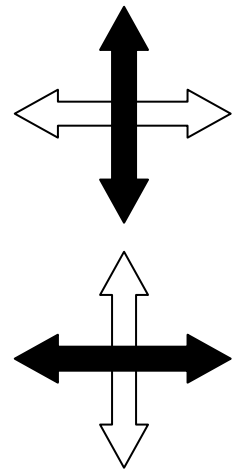

## Switch Functions

Functions illustrated as viewed from the driving position.

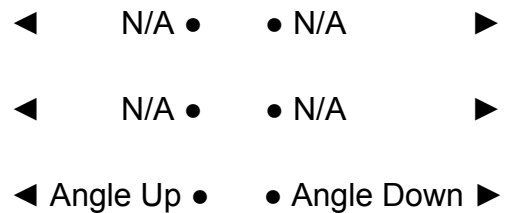
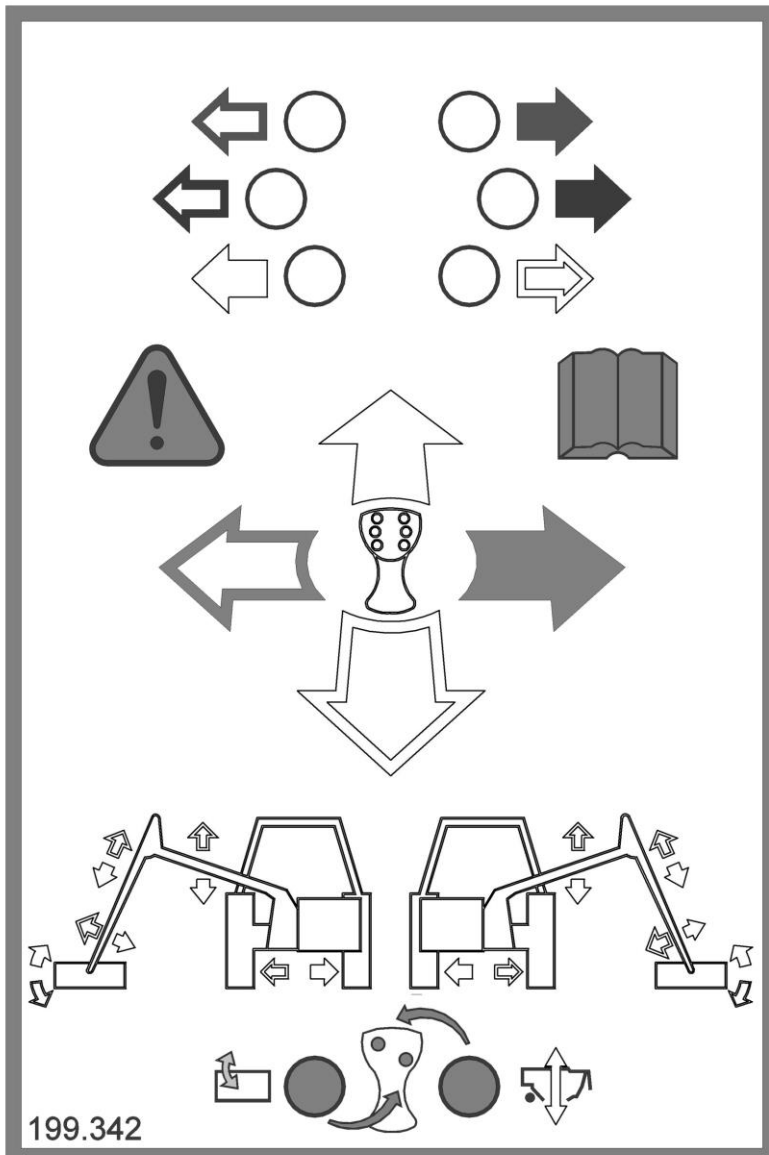

Float functions are located on the underside face of the joystick - Press once to engage, press again to disengage.

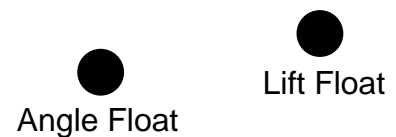

199.342



## TRANSPORT POSITION

---

For transport on the public highway the flailhead, or cutterbar, must be folded within the overall width of the tractor.

To allow the machine to be compactly folded the base of the breakaway ram and its fixing pins must be transferred from the outboard work position (A) and relocated to the inboard transport position (B) - see illustration opposite.

The procedure of moving the machine into the transport position is described below.

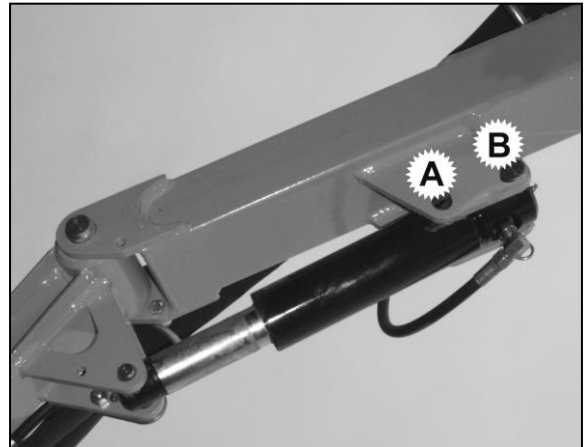

### Moving into Transport Position (Machine with Flailhead Fitted)

- Position the arm until the head is clear of the ground and the dipper vertical.
- Pull the dipper arm to the rear to release tension on the breakaway ram base pin and remove pin.
- Manually break back the dipper until the base of the ram is relocated between the inboard holes in the ram lugs, replace the ram base pin and secure with lock pin.
- Select 'Lift Up' until the main arm is as high as it can go without projecting beyond the tractors width. Fully select 'Reach In'. Select 'Angle Down' to turn the flails towards the tractor.

NOTE: For 'off road' transport where width is not critical it will be sufficient to just fold the arms.

### Moving into Transport Position (Machine with Cutterbar Fitted)

- With the cutterbar horizontal and the tractor switched off, fit the knife guard.  
**WARNING; Keep fingers away from the knife as it can move even with the tractor switched off.**
- Select 'Lift Up' until the main arm is as high as it can go without projecting beyond the tractors width. Fully select 'Reach In'. Fully select 'Angle Up'.

### Transport Speed

The acceptable speed of transport will vary greatly depending upon the ground conditions. In any conditions avoid driving at a speed which causes exaggerated bouncing as this will put unnecessary strain on the tractors top hitch position.

**WARNING: During transportation of the machine the PTO must be disengaged and power to the controls switched off.**

### Moving into Work Position

To revert to work mode the above procedures must be reversed.

**CAUTION: Ensure the base of the breakback ram is returned to the 'work' position before attempting to use the machine for duties – see above.**

## OPERATION

### Operator Guard

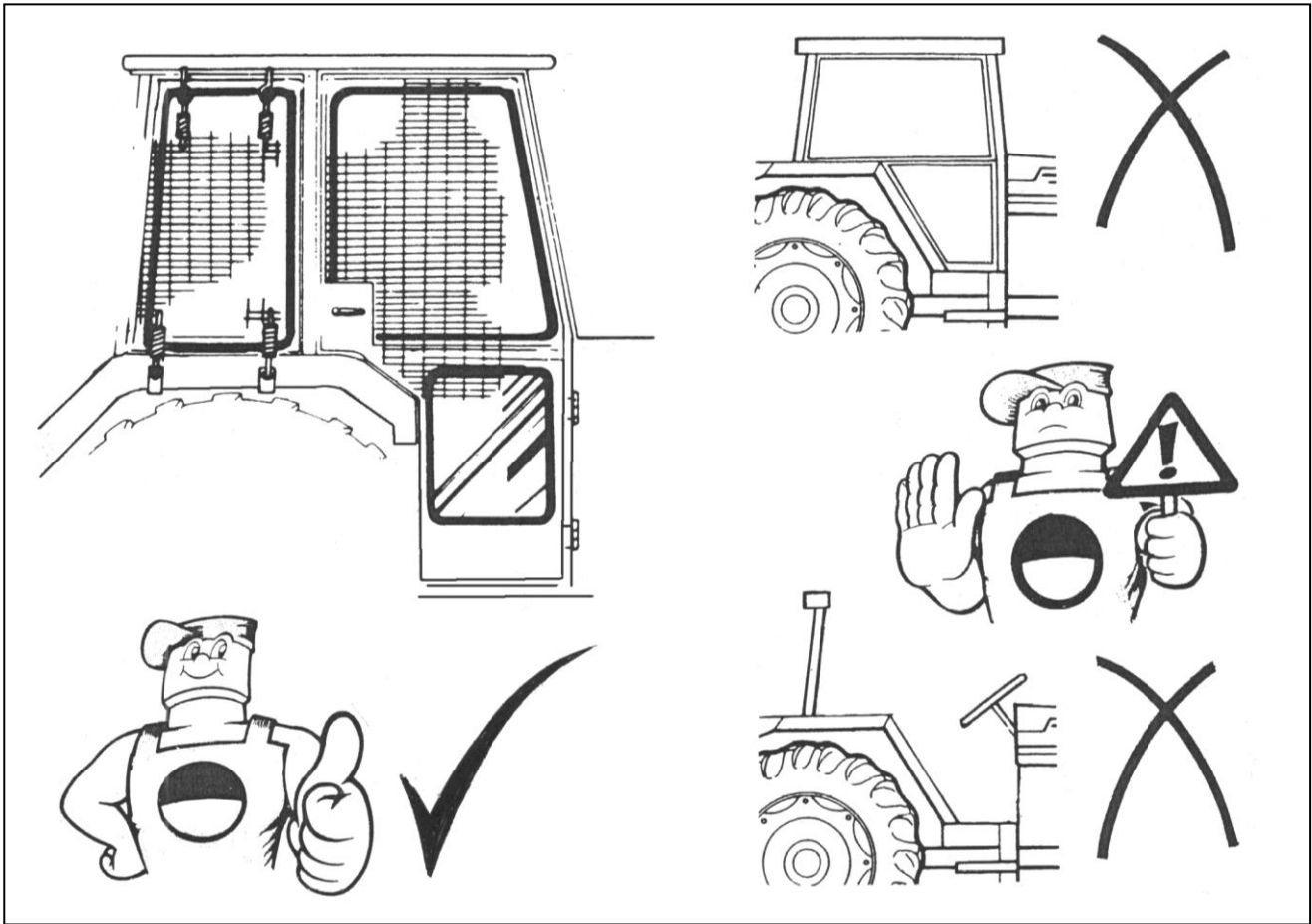

### Machine Guards

Before each period of work, check that all the relevant tractor and machine guards are in place and in good working condition.

Small splits and abrasions on the lower edges of the flail head rubber flaps are permissible, but should one or more of these cuts or splits become fifty per cent or more of the flap height they should be replaced immediately as they will have become ineffective for debris containment.

### Operator Safety

During operation all the tractor windows should be kept firmly closed with the exception of the rear window which may be opened only to the extent that is sufficient to allow entry of electrical or operating cables for the machine into the cab.

Should the tractor not be fitted with a 'quiet' cab ear defenders must be worn at all times, failure to heed this warning may result in permanent damage to hearing.

Although in normal circumstances a working machine or rotating parts should never be approached it is an additional wise precaution to avoid wearing loose or flapping clothes especially scarves and neckties whilst in close proximity to a machine.

The operator should continually guard himself and others from complacency that can arise from familiarity. Never attempt to take 'short cuts', always follow the correct procedures diligently and abide by the restrictions imposed by safety considerations.

**REMEMBER: there is only one right way - the safe way!**

## RUNNING UP PROCEDURE

---



**CAUTION:** Before initial use of a new machine, all lubrication points must be greased and the gearbox and oil tank levels checked and where required topped up before attempting to use the machine. *Refer to maintenance section for details.*

### Semi-Independent (SI) Models

- Ensure PTO lever is in the neutral position and isolate tractor hydraulic linkage.
- Start tractor and select external service supply – *allow the tractor to run for several minutes before attempting to operate any of the machine controls.*
- Check tractor rear axle oil level and top up if necessary.
- Ensure the motor hoses are connected correctly.
- Place cutter head at a safe attitude and bring tractor engine revs to 1000RPM.
- Engage PTO and allow the cutter to run for several minutes – do not leave the tractor cab or allow anyone to approach the cutter head whilst it is running.

**CAUTION:** Do not allow the pump to continue working if the cutter does not operate – overheating and serious damage to the pump can be caused in a very short time.

- After running up the machine increase PTO speed to approx. 360RPM - *allow the oil to circulate through the return line filter for about 5 minutes without operation of the armhead control lever.*
- Carefully operate the armhead controls through their complete range ensuring that all movements are functioning correctly.
- Disengaging PTO and stop the tractor.
- Check the hose runs to ensure that they are free from any pinching, chaffing, straining or kinks.
- Check the oil level in the tank and top up as necessary.

### Totally Independent (TI) Models

- Ensure that the rotor control valve is in 'Stop' position.
- Start tractor and engage PTO - *allow the oil to circulate through the return line filter for about 5 minutes without operation of the armhead control lever.*
- Carefully operate the armhead controls through their complete range ensuring that all movements are functioning correctly.
- Place the cutter head at a safe attitude and move the rotor control to 'Start' position, after initial fluctuation, the rotor should settle to a steady speed.
- Increase PTO speed to approximately 360RPM and run for a further five minutes before disengaging and stopping tractor.
- Check the hose runs to ensure that they are free from any pinching, chaffing, straining or kinks.
- Check the oil level in the tank and top up as necessary.

## ROTOR OPERATION – Reversing Rotation

---

### TI Machines

Depending on the particular build, rotor operation on machines with independent hydraulic systems will either be via a cable operated rotor control lever or by operation of the rotor control switch on the machines control unit – *refer to the previous controls section for specific details of operation.*

### SI Machines

On Semi-independent machines ROTOR ON/OFF is controlled by operation of the tractors PTO lever. The procedure for starting and stopping the rotor is as follows;

#### To start the rotor:

- Bring tractor engine revs up to 1000RPM
- Engage PTO

#### To stop the rotor:

- Disengage PTO **Do not leave tractor seat until the rotor is stationary.**

### Reversing Rotation

- Fully extend the armhead and lower flail to the ground (*this will minimise oil loss*).
- Release the hoses from the rotor relief valve and interchange (\*).

(\* ) IMPORTANT: *Do not interchange the flail supply and return hoses at any other point as the hose routing and cross overs in the installation are necessary to allow the hoses to flex correctly during normal arm movements.*

To ascertain the direction of cut without running the machine the following applies;

Connection P - (*lower motor rigid pipe*) }  
Connection MR - (*Upper motor right pipe*) } **upward cutting direction**

Connection P - (*Upper motor rigid pipe*) }  
Connection MR - (*Lower motor rigid pipe*) } **downward cutting direction**

### Cutterbars

On machines converted to cutterbar configuration check the hose connections to the cutterbar motor carefully as wrong connections could damage the knife drive. *Refer to specific cutterbar handbook for connection details.*



#### **CAUTION!**

**Never reverse the hydraulic oil flow direction of the cutterbar unit.**

## OPERATING SPEEDS

### PTO Operating Speed

The correct PTO speeds for operation of these machines is: **500 – 540RPM**

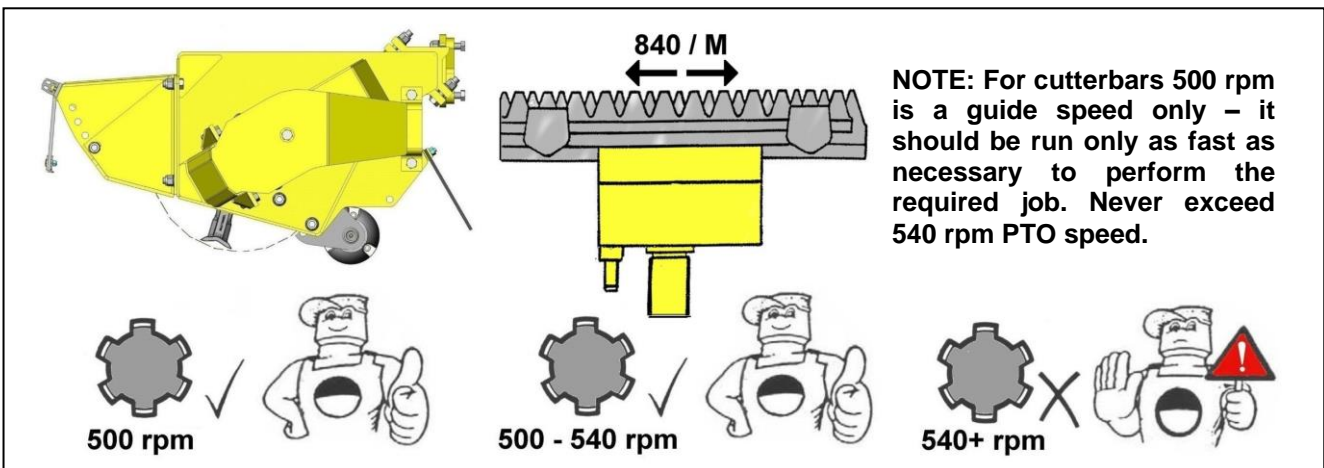

**WARNING:** Damage to the machine may occur if the maximum PTO speed is exceeded.

### Engaging Drive

- Ensure the rotor control lever/switch is in the 'stop' position before engaging the PTO.
- Allow the oil to circulate for a minute or so before operating the armhead controls.
- Move the flail head into a safe working position just clear of the material to be cut.
- Increase engine speed to a high idle and start the rotor – after initial 'surging' the rotor will run at an even speed.
- Carefully lower the flail head into the work area and begin work.

### Tractor Forward Speed

The material being cut will determine the tractor forward speed. Forward speed can be as fast as that which allows the flail head sufficient time to cut the vegetation both efficiently and neatly.

If forward speed is too fast this be indicated by over frequent operation of the breakaway system, a fall off in tractor revs and a poor untidy finish to the work leaving ragged uncut tufts and poorly mulched cuttings.

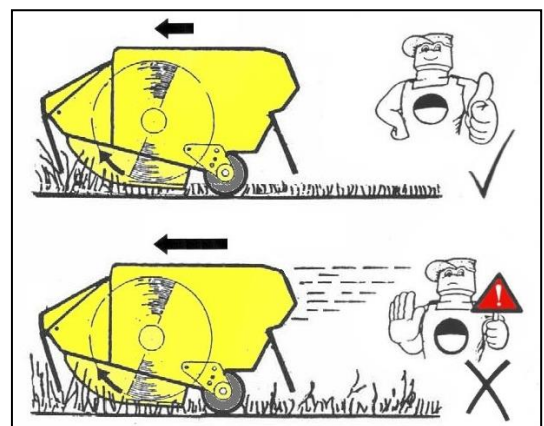

### 'Running In' - New Machines

For the first days work with a new machine it is recommended that tractor forward speed is restricted to 3 km/hr (2 mph) maximum. This will allow machine components 'bed in' and allow the operator to become familiar with the controls and their response under working conditions whilst operating at a relatively slow speed. If possible, select a first days work that affords mainly light to average cutting with occasional heavy duty work – *during this period check the tightness of nuts and bolts every hour, retightening as and when required.*

**First day use - check tightness of nuts & bolts hourly ►**

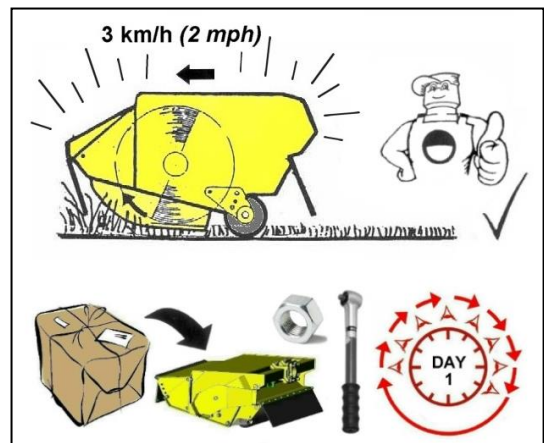

## BREAKAWAY PROTECTION SYSTEM

The machine is fitted with a hydraulic breakaway device which protects the structure of the machine should an unforeseen obstacle be encountered.

The breakaway system on these machines is in the form of a pivoted dipper arm and breakaway ram. The pivoted arm is held rigid and in line by the oil pressure in the fully extended breakaway ram. When the flail head meets an obstruction, and the tractor continues to move forward, oil pressure will build up against a relief valve situated in the base of the breakaway ram. When the preset pressure is reached the valve will blow and the oil will be vented into the lift ram, this will allow the flail head to pivot backwards and at the same time cause the arms to rise. When the obstruction is cleared oil pressure contained in the lift ram will cause the arm and flail head to return to the work position.

**NOTE: The breakaway function does not relieve the operator of his responsibility to drive carefully – always be alert and avoid obvious hazards before contact occurs.**

Breakaway may occur momentarily during normal work should an extra thick or dense patch of vegetation be encountered. In these instances tractor forward motion may be maintained with care.

Where breakaway has occurred as a result of contacting a post or tree etc. the tractor must be halted and the controls of the machine utilised to manoeuvre the head away from the obstacle. **Never continue forward motion to drag the head around the obstacle in breakback position.**

**NOTE: The force required to activate the breakaway system will vary dependent upon the gradient of work – It will require less force when working uphill and vice versa.**

## ANGLE FLOAT KIT (Standard on Cable Models / Option on Electric Models)

When activated the feature connects the base and gland circuits of the angle ram to allow free movement of oil in both directions thus allowing the head to automatically angle itself to match the contours of the ground. Refer to specific controls section for details of operation.

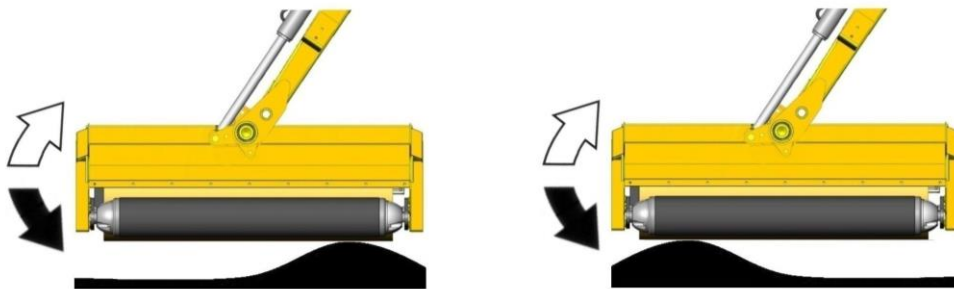

**Angle Float Off – Requires operator input to adjust flail head angle.**

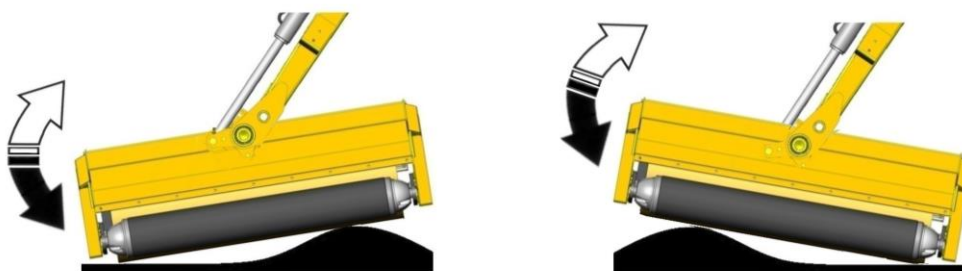

**Angle Float On – Flail head automatically angles itself to match the ground contours.**



## LIFT FLOAT (Optional Extra for Ground Work)

Work without lift float requires far more concentration and input from the operator to quickly react and re-adjust to the ground contours often resulting in patches of higher cut material where the head is cutting too high and ‘scalping’ of the ground where it is cutting too low – *in the case of the latter this can lead to increased flail wear, damage or even loss of flails.*

The Lift float feature is an optional extra for use during mowing work. When the function is activated the pressurised accumulator(s) work in conjunction with the valve and lift ram to take a proportion of the flailheads weight off the flail roller allowing the head to automatically follow the natural contours of the ground; this produces a cleaner more uniform cut without the need for constant operator re-adjustment.

Operation of the lift float function is as follows: with lift float switched off, position the flailhead approximately 1m clear of the ground before switching the float function on to charge the accumulator(s) – *the arms may drop at this point depending on the current level of retained pressure.* Lower the flailhead into the work position, release the lift control and proceed to work. *NOTE: occasional operation of the lift function will be required when working on downhill or uphill slopes and when reaching in or out in order to replenish the oil level within the accumulator(s) to retain optimum float capability.*

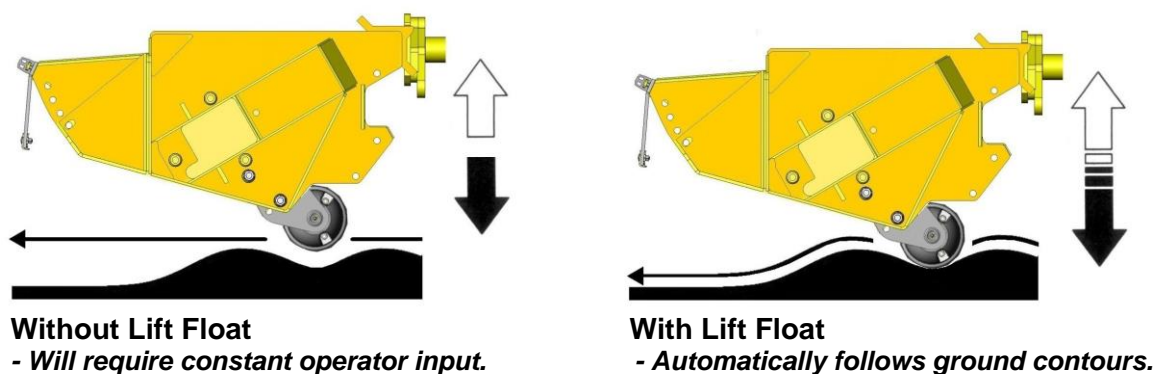

Lift float operation when supplied as a factory fitted option is controlled from the controls unit that accompanied the machine (*refer to controls section for details*), but the feature is also available for a range of models as an after market kit, in which case operation will either be via an auxiliary switch on cable controlled machines, or by utilisation of the auxiliary three-position type switch on the control unit of electric controlled machines - *this will allow for selection of 'lift float alone' or 'lift and angle float in unison' if both features are fitted.* Operation of the lift float control for these models will then be as specified in the main controls section.

### Power Connection on Cable Machines

On cable controlled machines the switch supplied will need to be mounted in a convenient location in the cab. The supply cable from the poppet valve solenoid must be connected into the tractors ignition system - the brown lead is positive and the blue lead is negative.

### Power Connection on Electric Machines

On electric controlled machines power to the unit is via the following connections:

Machines with 14 core looms use connection 10 and common connection 11.

Machines with 19 core looms use connection 15 and common connection 16.

V3 and V4 Non-EDS proportional machines use connections LF and C.

Depending on the particular machine after market lift float kits will either be frame mounted or ram mounted – they should be fitted and positioned in a location where they do not foul or interfere with other components during normal movements of the machine.

# HAZARDS & DANGERS

## Adverse Slopes

When working with the flailhead high and reach fully in it is possible for the main arm balance to go over centre and take the weight off the lift ram. A restrictor in the gland circuit of the lift ram will prevent sudden unpredictable movements if this should occur - *for reasons of safety this restrictor should not be removed.*

**DANGER!**



**NEVER REMOVE THE RESTRICTOR FROM THE LIFT RAM GLAND CIRCUIT.**

**Never work the machine on adverse slopes with the arms positioned such that the tractor is unbalanced ►**

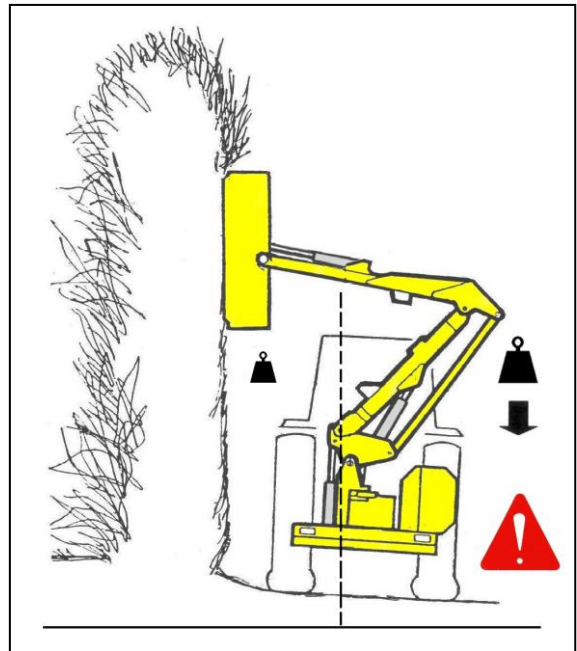

**DANGER!**



**NEVER CUT TO THE BLIND SIDE OF A HEDGE**  
- it is impossible to see any potential hazards or dangers and the position of the flail head would allow debris to be propelled through the hedge towards the tractor and operator.

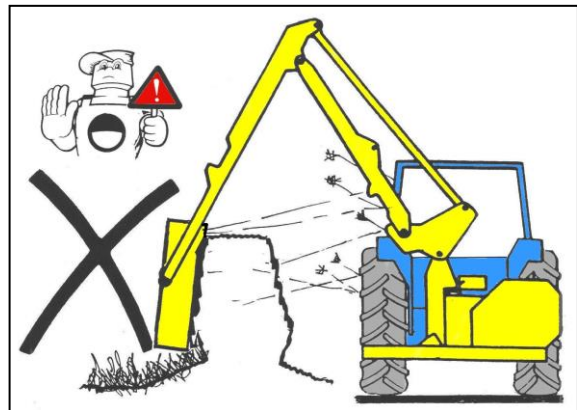

**DANGER!**



**NEVER OPERATE THE MACHINE WITH THE FLAIL HEAD ROLLER REMOVED**

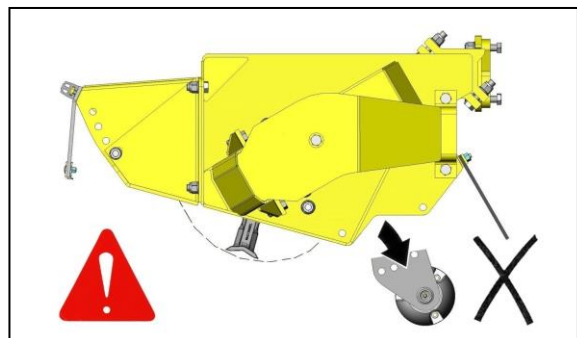

**DANGER!**



**WHEN GRASS MOWING THE ROTOR MUST ALWAYS CUT IN THE UPHILL DIRECTION WITH FRONT HOOD FITTED AND THE ROLLER POSITIONED BELOW THE CUTTING HEIGHT OF THE FLAILS**

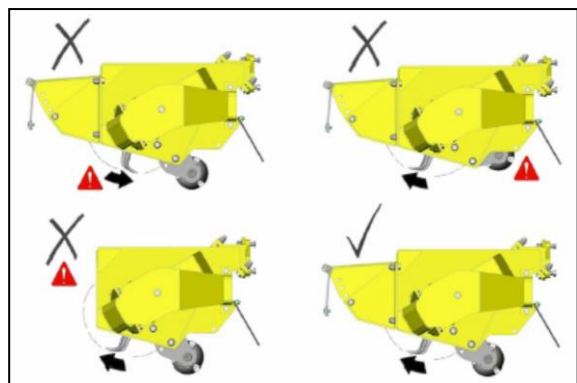



## OVERHEAD POWER LINES

### DANGER!

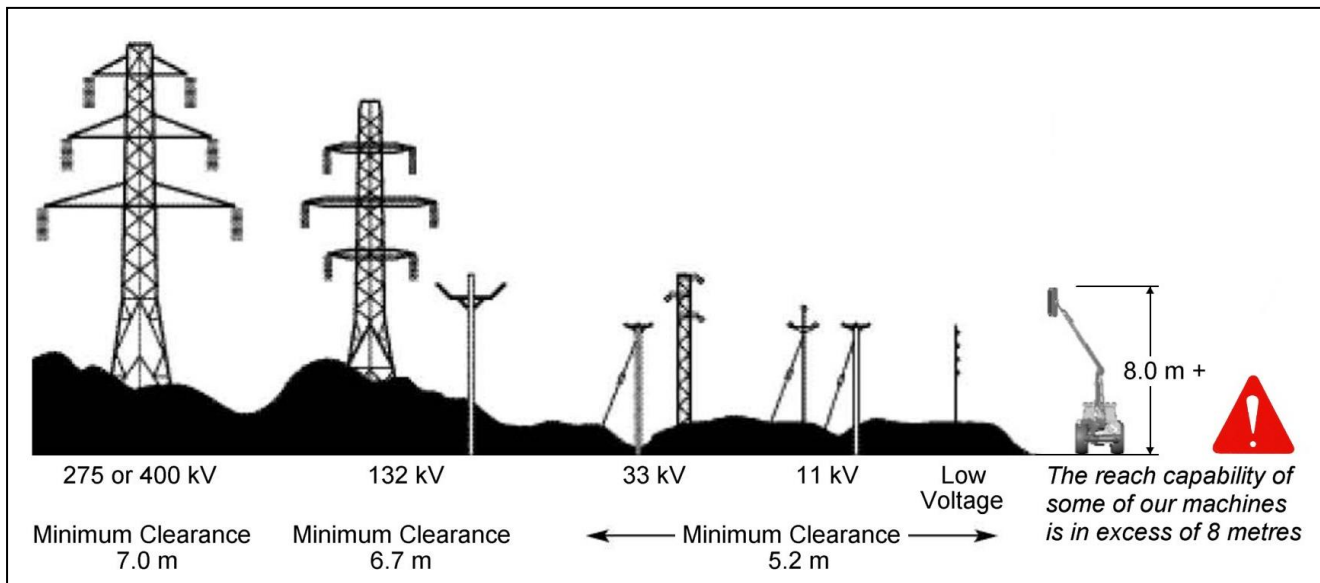

It cannot be stressed enough the dangers involved when working in the vicinity of overhead power cables. Some of our machines are capable of reach in excess of 8 metres (26') therefore they have the potential to well exceed, by possibly 3 metres (9' 9"), the lowest legal minimum height of 5.2 metres from the ground for 11,000 and 33,000 volt power lines. Remember electrocution can occur without actually coming into contact with a power line as electricity can 'flash over' when machinery gets close to it.

Before working in areas where overhead power lines are in close proximity the following steps must be observed:

**Find out** the maximum height and maximum vertical reach of your machine.

**Find out** the operating voltage of the power lines in the work area - Contact your local electricity company and/or National Grid Company who will be able to advise you on the operating voltage and safe minimum clearance distance for working.

**Always ensure** the safe minimum clearance recommendation is obeyed and work with extreme caution at all times.

**If doubt exists** do not work in the area – never risk the safety of yourself or others.

### Emergency Action for Accidents Involving Electricity

- ▲ Never touch an overhead line - even if it has been brought down by machinery, or has fallen. Never assume lines are dead.
- ▲ When a machine is in contact with an overhead line, electrocution is possible if anyone touches both the machine and the ground. Stay in the machine and lower any raised parts in contact or drive the machine out of the lines if you can.
- ▲ If you need to get out to summon help or because of fire, jump out as far as you can without touching any wires or the machine - keep upright and away.
- ▲ Get the electricity company to disconnect the supply. Even if the line appears dead, do not touch it - automatic switching may reconnect the power.

Further information and leaflets on this and other agricultural safety subjects are available on the 'Health & Safety Executive' website at the following address: [www.hse.gov.uk/pubns/agindex.htm](http://www.hse.gov.uk/pubns/agindex.htm)

## HEDGECUTTING PROCEDURE

Cut the side and bottom of the field side first. This leaves the maximum thickness of hedge on the road side to prevent the possibility of any debris being thrown through the hedge into the path of oncoming vehicles.

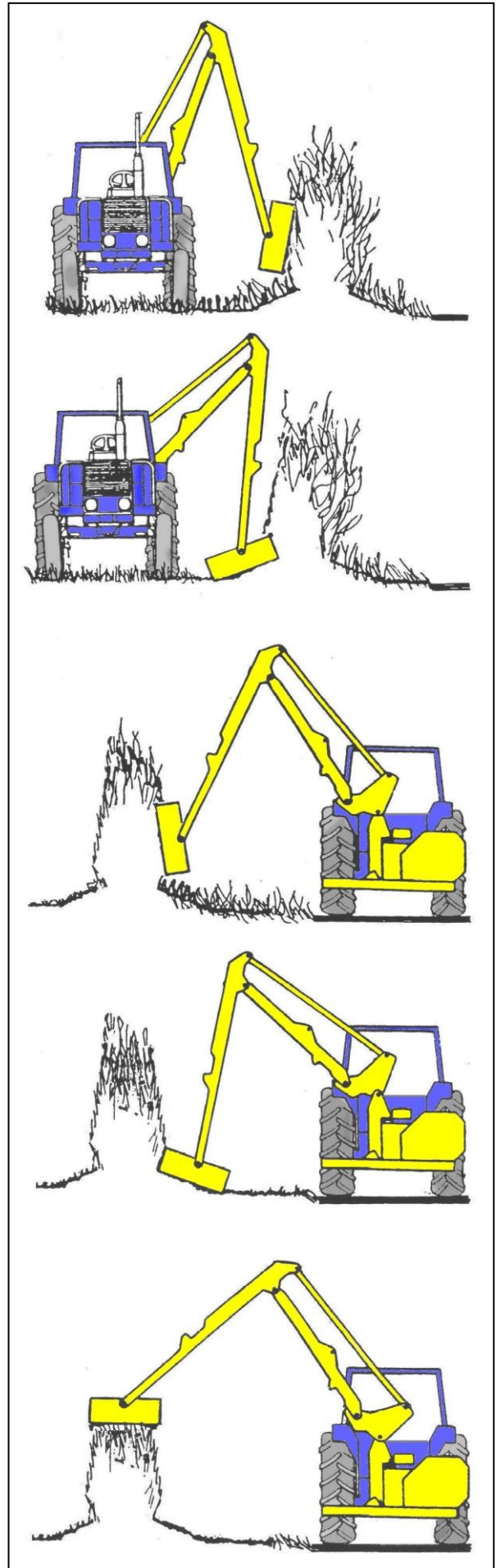

Cut the side and bottom of the road side.

Top cut the hedge to the height required.

# GENERAL MAINTENANCE

## General Lubrication

The illustration below indicates the general locations of lubrication points - all points should be greased on a daily basis and prior storage of the machine. **New machines must be greased prior to first use.**

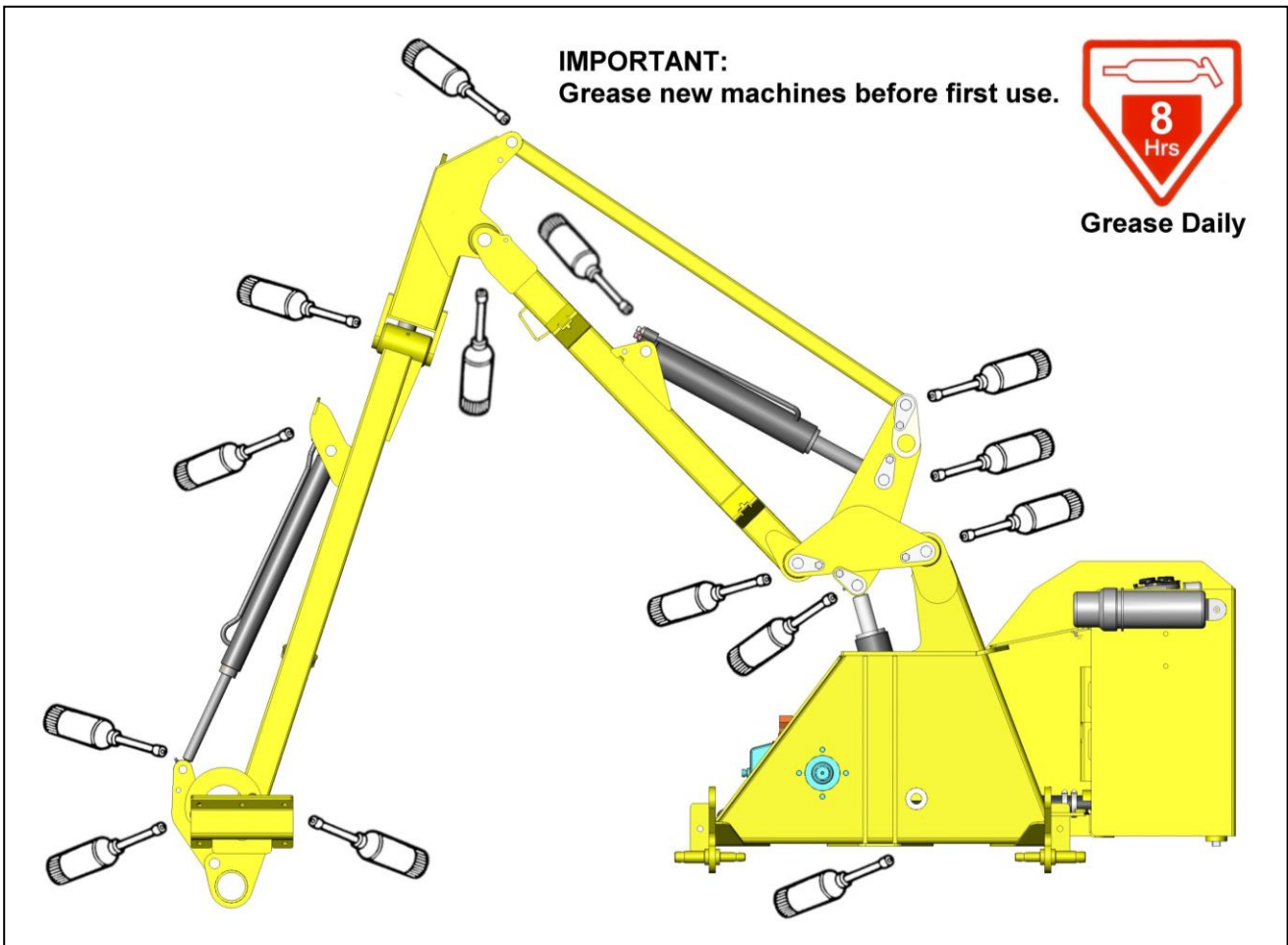

## Gearbox Lubrication

Refill the gearbox after an initial 50 hours of use and thereafter at annual or 500 hour intervals, whichever occurs earliest.

### Gearbox Capacity:

**0.7 Litre SAE75W90 Fully Synthetic which meets the following minimum requirements;**

Viscosity at 40°C, cSt, 100.0 min.

Viscosity at 100°C, cSt, 17.2 min.

	<b>SAE75W90</b> <b>0.7L</b>	
	<b>FULLY SYNTHETIC</b>	

Drainage of the gearbox for oil changes is via the drain plug 'B' located on the base of the gearbox. For refilling or for 'topping up' the oil remove plugs at positions 'A' & 'C' illustrated opposite and refill gearbox via 'A' to a point where the oil starts to weep from the level plug orifice 'C' – *replace both plugs and tighten securely.*

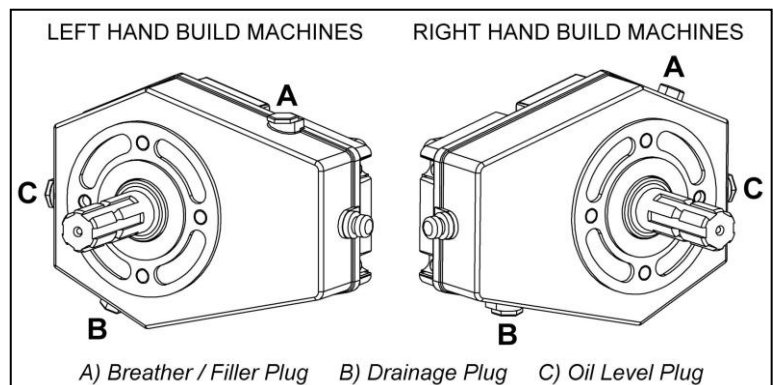

## SERVICE SCHEDULE

---

### Every Day

- Grease machine fully prior to work (and prior to storage).  
*NOTE: New machines must be greased before initial use.*
- Check for broken or damaged flails.
- Check tightness of flail nuts and bolts.
- Visually check for oil leaks and damaged hoses.
- Check all guards and safety shields are correctly fitted and undamaged.
- Ensure all lights are working and clean.
- Check oil level.
- Clean the cooler matrix, in dusty conditions more frequent cleaning is required.

### After initial 12 Hours

- Change return line filter element. *Failure to do so will invalidate the warranty.*  
*Note; factory fitted filter elements are identified differently to replacement elements.*

### After initial 50 Hours

- Change gearbox oil.

### Every 25 Hours

- Grease PTO Shaft universal joints and tubes.

### Every Week

- Check tightness of all nuts and bolts.
- Check gearbox oil level.
- Check for wear on telescopic arm pads – *where applicable.*

### Every 100 Hours

- Grease PTO shaft shield lubrication points.

### Every 500 Hours

- Change return line filter element.
- Change gearbox oil.
- Check condition of hydraulic oil and change if required; *when changing oil new return line filter and suction strainer elements should be fitted and return line filter changed again after 12 hours of work.*

### Annually

- Change tank breather.

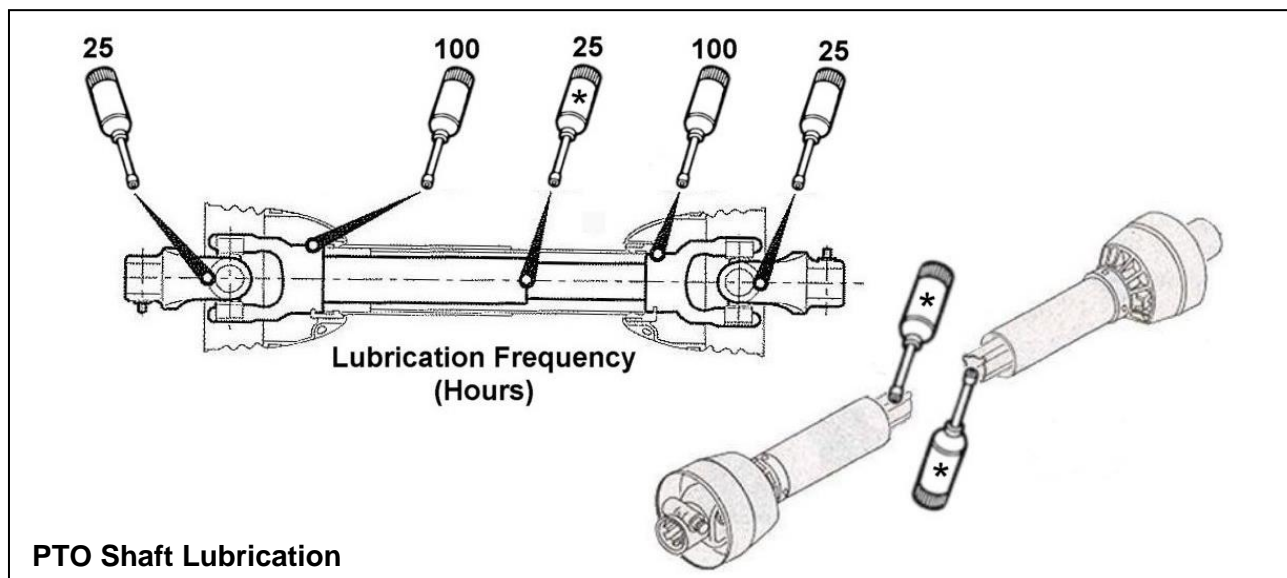

# HYDRAULIC SYSTEM

---

## Oil Supply

Check the oil level in the reservoir daily.

## Oil Condition & Replacement

No fixed time period can be quoted for oil changes as operating conditions can vary widely but a visually inspection of the oil will often indicate its current overall state. Signs of a reduction in its condition will be apparent by changes in colour and appearance when compared to new oil. Oil in poor condition can be dark, smell rancid or burnt, or in some cases be yellow, unclear or milky in appearance indicating the presence of air or emulsified water. Moisture resulting from condensation can become entrapped in the oil causing emulsification that can block the return line filter, consequentially the filter system will be by-passed and the oil and any possible contaminants present will continue to circulate without filtration risking damage to hydraulic components. All are indications or conditions that will require replacement of the oil.

Hydraulic oil is a vital component of the machine; contaminated oil is the root cause of 70% of all hydraulic system failures. Contamination can be reduced by the following:

- Cleaning around the reservoir cap before removal, and keeping the tank area clean.
- Use of clean containers when replenishing the system.
- Regular servicing of the filtration system.

## Filtration System

Machines are protected by both replaceable 125 micron suction strainers and low pressure 25 micron full flow return line filters – the diagram below is a 'scaled up' view illustrating the filtering capability built into the hydraulic system of the machine:

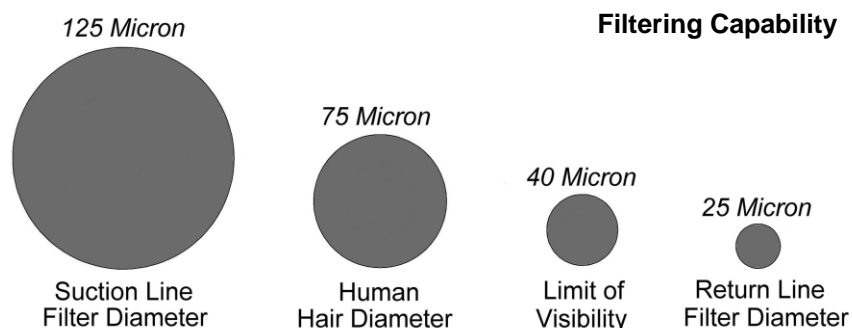

## Suction strainers

The replaceable 125 micron suction strainers are fitted within the hydraulic tank and are 'screw' fitted with easy access for removal and replacement.

## Return Line Filter

The 25 micron absolute filter elements should be changed after the first 12 hours and thereafter at 500-hour intervals. It is important to note hours worked as if the filter becomes blocked an internal by-pass within the canister will operate and no symptoms of filter malfunction will occur to jog your memory.

## Tank Breather

To reduce the risk of pump cavitation it is advisable to replace the 25 micron absolute tank breather on an annual basis under normal working conditions – for machines operating in dry dusty environments it is recommended that replacement be increased to 6 monthly.

## HYDRAULIC HOSES

---

The condition of all hoses should be carefully checked during routine service of the machine. Hoses that have been chaffed or damaged on their outer casing should be securely wrapped with waterproof adhesive tape to stop the metal braid from rusting. Hoses that have suffered damage to the metal braid should be changed at the earliest opportunity.

### Hose Replacement

Before changing any hoses take the time to study the existing installation as the routing has been carefully calculated to prevent hose damage during operation - always replace hoses in exactly the same location and manner. This is especially important for the flail hoses where they must be crossed, upper to lower, at the dipper and head pivots.

- Always replace one hose at a time to avoid the risk of wrong connections.
- When the hose is screwed to an additional fitting or union, use a second spanner on the union to avoid breaking both seals.
- Do not use jointing compound on the threads.
- Avoid twisting the hose. Adjust the hose line to ensure freedom from rubbing or trapping before tightening hose end connections.

All Hydraulic Hoses (BSP) now fitted to Twose Hedgecutters have 'soft seal' connections on both flail and ram circuit hoses.

Recommended torque settings for nut security are as follows:

SIZE		TORQUE SETTING			O Ring Ref.
1/4" BSP	=	24 Nm	<i>or</i>	18 lb.ft.	10 000 01
3/8" BSP	=	33 Nm	<i>or</i>	24 lb.ft.	10 000 02
1/2" BSP	=	44 Nm	<i>or</i>	35 lb.ft.	10 000 03
5/8" BSP	=	58 Nm	<i>or</i>	43 lb.ft.	10 000 04
3/4" BSP	=	84 Nm	<i>or</i>	62 lb.ft.	10 000 05
1" BSP	=	115 Nm	<i>or</i>	85 lb.ft.	10 000 06

For hose unions (BSP) fitted in conjunction with bonded seals the recommended torque settings are as follows:

SIZE		TORQUE SETTING		
1/4" BSP	=	34 Nm	<i>or</i>	25 lb.ft.
3/8" BSP	=	75 Nm	<i>or</i>	55 lb.ft.
1/2" BSP	=	102 Nm	<i>or</i>	75 lb.ft.
5/8" BSP	=	122 Nm	<i>or</i>	90 lb.ft.
3/4" BSP	=	183 Nm	<i>or</i>	135 lb.ft.
1" BSP	=	203 Nm	<i>or</i>	150 lb.ft.

### Safety Note:

Soft seal hose connections are capable of holding pressure when the nut is only 'finger tight'. It is therefore recommended during dismantling that the hose be manually flexed to relieve any residual pressure with the retaining nut slackened prior to complete disassembly.



# PTO SHAFT MAINTENANCE

## PTO Shaft Lubrication

The PTO shaft should be lubricated on a regular basis using lithium based grease – each end of the shaft has 2 greasing points; one for lubrication of the universal joint and one for lubricating the rotating fixing ring of the shaft shield – access to the lubrication points is gained by releasing the shaft shield from its fixing ring and sliding it back along the body of the driveshaft – *the procedure and lubrication frequency is illustrated below.*



Shaft shield fixing clasps



Insert screwdrivers into the clasps

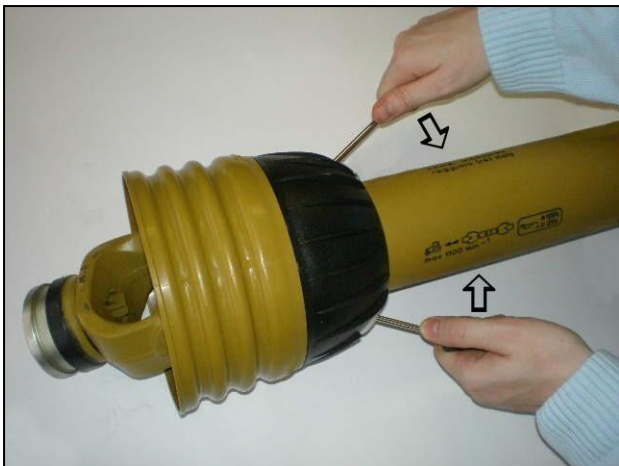

Prise clasps open to release the shield



Slide shield back to reveal universal joint

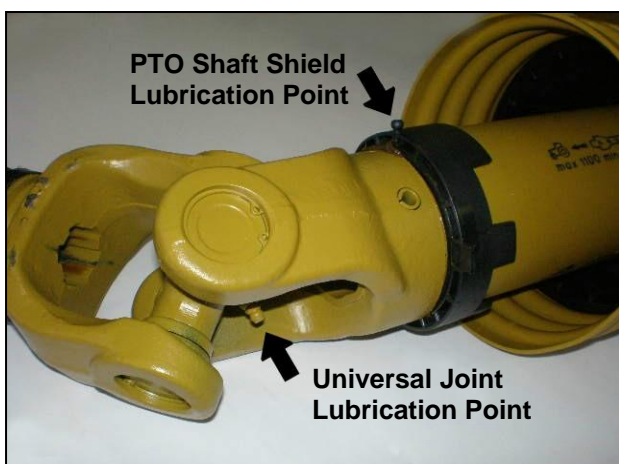

Location of lubrication points



Recommended lubricating frequency

Slide the shaft shield back into place after lubrication ensuring the clasps relocate correctly in the fixing ring – always fit torque chains to the shields to stop them from rotating with the shaft during operation.

## TORQUE SETTINGS FOR FASTENERS

The chart below lists the correct tightening torque for fasteners. This chart should be referred to when tightening or replacing bolts in order to determine the grade of bolt and the correct torque unless specific torque values are assigned in the text of the manual.

*Recommended torque is quoted in Foot-Pounds and Newton-Metres within this manual. The equation for conversion is 1 Nm. = 1.356 ft. lbs.*

### TORQUE VALUES FOR IMPERIAL BOLTS

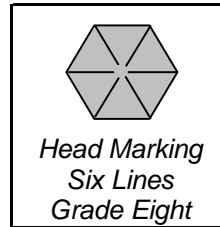
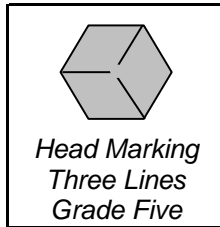
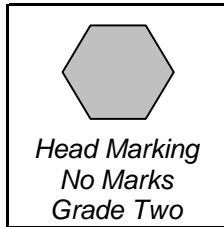

**NOTE:**  
The values in the chart apply to fasteners as received from the supplier, dry or when lubricated with normal engine oil. They DO NOT apply if special graphited, molydisulphide greases, or other extreme pressure lubricants are used. This applies to both UNF and UNC coarse threads.

Bolt Dia.
1/4"
5/16"
3/8"
7/16"
1/2"
9/16"
5/8"
3/4"
7/8"
1"
1-1/8"
1-1/4"
1-3/8"
1-1/2"

Value (Dry)	
ft.lb.	Nm.
5.5	7.5
11	15.0
20	27.0
32	43.0
50	68.0
70	95.0
100	135.0
175	240.0
175	240.0
270	360.0
375	510.0
530	720.0
700	950.0
930	1250.0

Value (Dry)	
ft.lb.	Nm.
9	12.2
18	25.0
33	45.0
52	70.0
80	110.0
115	155.0
160	220.0
280	380.0
450	610.0
675	915.0
850	115.0
1200	1626.0
1550	2100.0
2100	2850.0

Value (Dry)	
ft.lb.	Nm.
12.5	17.0
26	35.2
46	63.0
75	100.0
115	155.0
160	220.0
225	305.0
400	540.0
650	880.0
975	1325.0
1350	1830.0
1950	2650.0
2550	3460.0
3350	4550.0

### TORQUE VALUES FOR METRIC BOLTS.

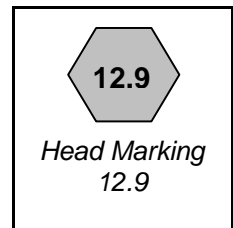
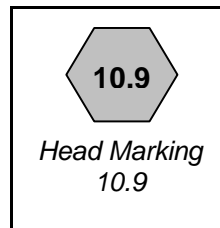
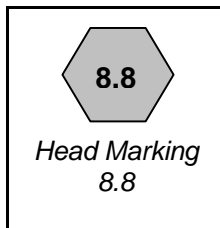
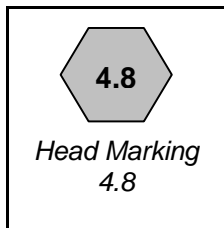
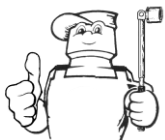

Bolt Dia.
6mm
8mm
10mm
12mm
14mm
16mm
18mm
20mm
22mm
24mm
27mm
30mm

Value (Dry)	
ft.lb.	Nm.
4.5	6.1
11	14.9
21	28.5
37	50.2
60	81.4
92	125.0
125	170.0
180	245.0
250	340.0
310	420.0
450	610.0
625	850.0

Value (Dry)	
ft.lb.	Nm.
8.5	11.5
20	27.1
40	54.2
70	95.0
110	150.0
175	240.0
250	340.0
350	475.0
475	645.0
600	810.0
875	1180.0
1200	1626.0

Value (Dry)	
ft.lb.	Nm.
12	16.3
30	40.1
60	81.4
105	140.0
165	225.0
255	350.0
350	475.0
500	675.0
675	915.0
850	1150.0
1250	1700.0
1700	2300.0

Value (Dry)	
ft.lb.	Nm.
14.5	20.0
35	47.5
70	95.0
120	160.0
190	260.0
300	400.0
410	550.0
580	790.0
800	1090.0
1000	1350.0
1500	2000.0
2000	2700.0







McConnel Limited, Temeside Works, Ludlow, Shropshire SY8 1JL. England.  
Telephone: 01584 873131. Facsimile: 01584 876463. [www.mcconnel.com](http://www.mcconnel.com)