

Fransgård

Manual
GB

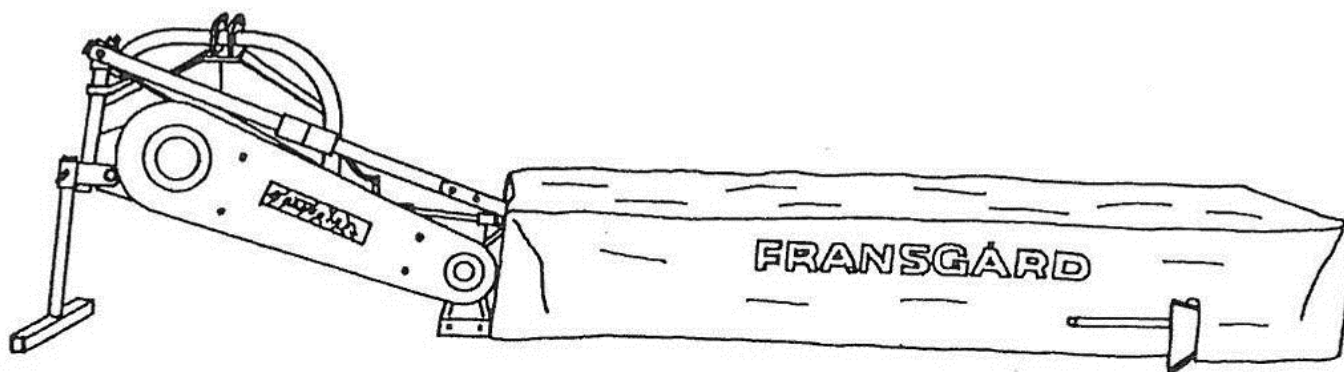

Disc mower

K-280

From serial number : 113954 →

Fransgård

Fredbjergvej 132, Denmark-9640 Farsø www.fransgard.dk

Model	K-280
Kg.	490
KW	45
Serie nr.	



Made in Denmark

Fransgård Maskinfabrik A/S
Fredbjergvej 132
DK - 9640 Farsø
Telefon : +45 98 63 21 22
Fax : +45 98 63 18 65
www.fransgard.dk
mail@fransgard.dk

LIST OF CONTENTS

Page

Technical Specifications.....	1
Safety Precautions	2
Assamble instruksjon	2
Working position	3
Overload release.....	3
Transport position.	3
Ordering spare parts	4
Lubrication and Maintenance	4

TECHNICAL SPECIFICATIONS

Working width.....	2,80m/9'3".
Transport width	1,90m/6'3".
Working speed,max.	6-15km/h 3,5-9 mph.
Power Requirement	60HP/45kW.
Power Take-off.....	540 revs./min.
Number of discs	7.
Number of blades.....	14.
Weight.....	490 kg/1070 lbs.

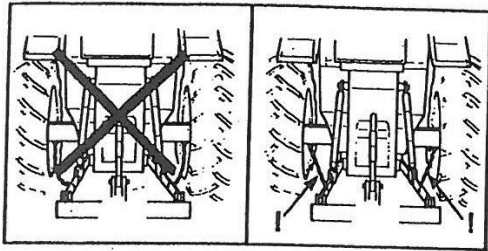
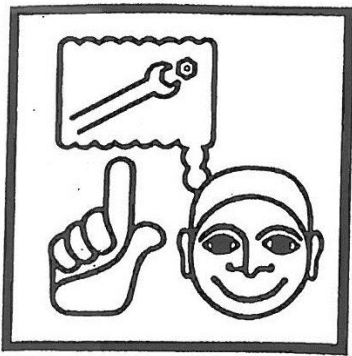

SAFETY PRECAUTIONS

All screens must be correctly positioned and checked before starting the machine. Take care for stone fling. It is not advisable to remain in the working area of the machine while working parts are rotating.

The machine is made to work in grass and strawcrops, and must not be used for anything else.

The machine must only be operated by qualified operator.

Machine lubrication, adjustment may only take place while the machine is not in use and while the power take-off is switched off.

In transport position with the cutterbar in vertical position must the safety chain be mounted.

Tighten bolts and check settings after approx. 5 hours of use.

Bladebolts and disc bolts must be correct tightent.

If blades are changed, make sure they are proper mounted.

The machine must only be started when it is lowered.

The rpm. of the PTO. must not exceed the recommended PTO. speed.

The field must be cleared for foreign objects.

The main cover can be weared and has to be changed in time.

Only use original Fransgård spare parts.

Read instructions for use carefully before starting.

ASSEMBLE INSTRUCTION

Bolts,nuts and special pin's etc. are mounted on the machine where you need it.

See the mounting / spare parts drawings on the following pages.

Tilt the Carrying frame pos.38 page 8 round, and mount the three-point hitch by means of the suspension fork pos.19. Mount the carrying frame pos.12 page 14 on the gearbox, and mount the bracket pos.7. Mount the bracket and the canvas pos.1 and 19. Mount the swathdeflector pos.16 and 18. Mount the stabilizer pos.31 and 32 page 8 into the suspension fork pos.19 together with the unloading device pos.26, the lock pos.17 and the spring pos.21. Mount the release bracket as follow, the spring must face cutterbar and must be near the carrying frame.

Ajust the spring under the unloading device asfollow, the transport lock must be unlockt and the suspension fork must be to the right into the slide, then tighten the spring by means of the eye bolt pos.22 just as much as the spring start tighten up.

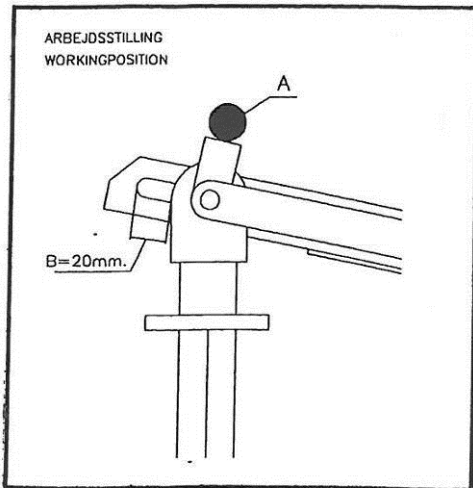

WORKING POSITION

Dismount the safety chain and release the transport lock (A).
 Lower the cutterbar until there is about 20mm. in free of the slide (B) see the illustration.

Adjust the tractor's depth stop, if the tractor's depth stop is in bad condition, then use enclosed bracket, and tighten the safety chain into the topbar bracket on the tractor, so the machine can be kept in place.

The hydraulic cylinder must be floating.

Tilt the protection guard forward.

Adjust the cutting height by using the topbar.

OVERLOAD RELEASE.

The overload release near the three point lift is a safety guard which allow the cutterbar swing backward if it hit's into the ground,

when it happen then stop the PTO. and drive backward and the overload release are going to lock again.

TRANSPORT POSITION

Change-over from working position to transport position is as follows:

Lift the machine from the ground. Tilt the front swath guard backwards and drag the canvas free of the brackets, so it not are getting damaged.

Drag the cutterbar up into vertical position by means of the hydraulic cylinder and lock it by means of the safety chaine.

Turn the transport lock (A) on, in the left side.

ORDERING SPARE PARTS

The spare part order must contain the following information:

1. Machine type.
2. Spare part number and description-possibly dimensions and number of parts.

LUBRICATION AND MAINTENANCE

Lubricate PTO shaft after every 10 hours of operation, and lubricate the indicated lubrication points as and when required.

Retighten bolts.

Correct tighten of knifebolt - 10 kpm.

Correct tighten of discbolt - 17 kpm.

Check the V-belts before every start, when the V-belts is proper tightened it can be pushed approx 20mm. in the middle between the pulleys.

The V-belts conditions has to be checked by dismount the cover.

Is a V-belt defect, exchange the whole set.

Is the machine put away for the winter, the V-belts has to be released.

At regular intervals, and at least twice a week, check the cutterbar for dirt and clean if required.

An unbalance will reduce the life of the bar.

Check the oil level in the gearbox, by means of the levelindicator under the plug on top of gearbox the cutterbar must be horizontal.

The gearbox is filled with 0,7 litres of SAE 80/90 W gearoil. It should be checked daily and topped up if necessary.

Check oil level on the cutterbar when it is in vertical position, on the disc side there is one plug, for controlling oil level and filling oil into the bar.

Under the cutterbar in the bottom is one plug (A) for taking oil of the bar.

The cutterbar is filled with 3,2 litres of SAE 80/90 W gearoil. It should be checked daily and topped up if necessary.

Change oil after approx 10 hours of use, and then every 100 hours at least once a year.

