

# **DISC MOWER**

## **DS270S / DS300S / DS340S**

### **OPERATION MANUAL**

*Publication 559*

*Part No.41571.59*



Twose of Tiverton Limited  
6 Chinon Court,  
Lower Moor Way,  
Tiverton Business Park,  
Tiverton,  
Devon. EX16 6SS.  
Telephone: (01884) 253691  
Fax: (01884) 255189  
Email [sales@twose.com](mailto:sales@twose.com)  
Web: [www.twose.com](http://www.twose.com)



# IMPORTANT VERIFICATION OF WARRANTY REGISTRATION



## DEALER WARRANTY INFORMATION & REGISTRATION VERIFICATION

It is imperative that the selling dealer registers this machine with Twose of Tiverton Limited before delivery to the end user – failure to do so may affect the validity of the machine warranty.

To register machines go to the Twose web site at [www.twose.com](http://www.twose.com), log onto 'Dealer Inside' and select the 'Machine Registration button' which can be found in the Service Section of the site. Confirm to the customer that the machine has been registered in the section below.

Should you experience any problems registering a machine in this manner please contact the Twose Office on 01884 253691.

### Registration Verification

Dealer Name: .....
Dealer Address: .....
Customer Name: .....
Date of Warranty Registration: ...../...../..... Dealer Signature: .....

### NOTE TO CUSTOMER / OWNER

*Please ensure that the above section above has been completed and signed by the selling dealer to verify that your machine has been registered with Twose of Tiverton Limited.*

**IMPORTANT:** During the initial 'bedding in' period of a new machine it is the customer's responsibility to regularly inspect all nuts, bolts and hose connections for tightness and re-tighten if required. New hydraulic connections occasionally weep small amounts of oil as the seals and joints settle in – where this occurs it can be cured by re-tightening the connection – *refer to torque settings chart below*. The tasks stated above should be performed on an hourly basis during the first day of work and at least daily thereafter as part of the machines general maintenance procedure.

### TORQUE SETTINGS FOR HYDRAULIC FITTINGS

HYDRAULIC HOSE ENDS		
BSP	Setting	Metric
1/4"	18 Nm	19 mm
3/8"	31 Nm	22 mm
1/2"	49 Nm	27 mm
5/8"	60 Nm	30 mm
3/4"	80 Nm	32 mm
1"	125 Nm	41 mm
1.1/4"	190 Nm	50 mm
1.1/2"	250 Nm	55 mm
2"	420 Nm	70 mm

PORT ADAPTORS WITH BONDED SEALS		
BSP	Setting	Metric
1/4"	34 Nm	19 mm
3/8"	47 Nm	22 mm
1/2"	102 Nm	27 mm
5/8"	122 Nm	30 mm
3/4"	149 Nm	32 mm
1"	203 Nm	41 mm
1.1/4"	305 Nm	50 mm
1.1/2"	305 Nm	55 mm
2"	400 Nm	70 mm

# WARRANTY POLICY

## WARRANTY REGISTRATION

All machines must be registered, by the selling dealer with Twose of Tiverton Ltd, before delivery to the end user. On receipt of the goods it is the buyer's responsibility to check that the Verification of Warranty Registration in the Operator's Manual has been completed by the selling dealer.

### 1. LIMITED WARRANTIES

- 1.01. *All machines supplied by Twose of Tiverton Ltd are warranted to be free from defects in material and workmanship from the date of sale to the original purchaser for a period of 12 months, unless a different period is specified.*
- 1.02. *All spare parts supplied by Twose of Tiverton Ltd and purchased by the end user are warranted to be free from defects in material and workmanship from the date of sale to the original purchaser for a period of 6 months. All parts warranty claims must be supported by a copy of the failed part invoice to the end user. We cannot consider claims for which sales invoices are not available.*
- 1.03. *The warranty offered by Twose of Tiverton Ltd is limited to the making good by repair or replacement for the purchaser any part or parts found, upon examination at its factory, to be defective under normal use and service due to defects in material or workmanship. Returned parts must be complete and unexamined. Pack the component(s) carefully so that any transit damage is avoided. All ports on hydraulic items should be drained of oil and securely plugged to prevent seepage and foreign body ingress. Certain other components, electrical items for example, may require particular care when packing to avoid damage in transit.*
- 1.04. *This warranty does not extend to any product from which Twose of Tiverton Ltd's serial number plate has been removed or altered.*
- 1.05. *This warranty does not apply to any part of the goods, which has been subjected to improper or abnormal use, negligence, alteration, modification, fitment of non-genuine parts, accident damage, or damage resulting from contact with overhead power lines, damage caused by foreign objects (e.g. stones, iron, material other than vegetation), failure due to lack of maintenance, use of incorrect oil or lubricants, contamination of the oil, or which has served its normal life. This warranty does not apply to any expendable items such as blades, belts, clutch linings, filter elements, flails, flap kits, skids, soil engaging parts, shields, guards, wear pads, pneumatic tyres or tracks.*
- 1.06. *Temporary repairs and consequential loss - i.e. oil, downtime and associated parts are specifically excluded from the warranty.*
- 1.07. *Warranty on hoses is limited to 12 months and does not include hoses which have suffered external damage. Only complete hoses may be returned under warranty, any which have been cut or repaired will be rejected.*
- 1.08. *Machines must be repaired immediately a problem arises. Continued use of the machine after a problem has occurred can result in further component failures, for which Twose of Tiverton Ltd cannot be held liable, and may have safety implications.*
- 1.09. *If in exceptional circumstances a non Twose of Tiverton Ltd part is used to effect a repair, warranty reimbursement will be at no more than Twose of Tiverton Ltd's standard dealer cost for the genuine part.*
- 1.10. *Except as provided herein, no employee, agent, dealer or other person is authorised to give any warranties of any nature on behalf of Twose of Tiverton Ltd.*
- 1.11. *For machine warranty periods in excess of 12 months the following additional exclusions shall apply:*
  - 1.11.1. *Hoses, exposed pipes and hydraulic tank breathers.*
  - 1.11.2. *Filters.*
  - 1.11.3. *Rubber mountings.*
  - 1.11.4. *External electric wiring.*
  - 1.11.5. *Bearings and seals.*

- 1.12. All service work, particularly filter changes, must be carried out in accordance with the manufacturer's service schedule. Failure to comply will invalidate the warranty. In the event of a claim, proof of the service work being carried out may be required.
- 1.13. Repeat or additional repairs resulting from incorrect diagnosis or poor quality previous repair work are excluded from warranty.

**NB Warranty cover will be invalid if any non-genuine parts have been fitted or used. Use of non-genuine parts may seriously affect the machine's performance and safety. Twose of Tiverton Ltd cannot be held responsible for any failures or safety implications that arise due to the use of non-genuine parts.**

## **2. REMEDIES AND PROCEDURES**

- 2.01. The warranty is not effective unless the Selling Dealer registers the machine, via the Twose of Tiverton Ltd web site and confirms the registration to the purchaser by completing the confirmation form in the operator's manual.
- 2.02. Any fault must be reported to an authorised Twose of Tiverton Ltd dealer as soon as it occurs. Continued use of a machine, after a fault has occurred, can result in further component failure for which Twose of Tiverton Ltd cannot be held liable.
- 2.03. Repairs should be undertaken within two days of the failure. Claims submitted for repairs undertaken more than 2 weeks after a failure has occurred, or 2 days after the parts were supplied will be rejected, unless the delay has been authorised by Twose of Tiverton Ltd. Please note that failure by the customer to release the machine for repair will not be accepted as a reason for delay in repair or submitting warranty claims.
- 2.04. All claims must be submitted, by an authorised Twose of Tiverton Ltd Service Dealer, within 30 days of the date of repair.
- 2.05. Following examination of the claim and parts, Twose of Tiverton Ltd will pay, at their discretion, for any valid claim the invoiced cost of any parts supplied by Twose of Tiverton Ltd and appropriate labour and mileage allowances if applicable.
- 2.06. The submission of a claim is not a guarantee of payment.
- 2.07. Any decision reached by Twose of Tiverton Ltd is final.

## **3. LIMITATION OF LIABILITY**

- 3.01. Twose of Tiverton Ltd disclaims any express (except as set forth herein) and implied warranties with respect to the goods including, but not limited to, merchantability and fitness for a particular purpose.
- 3.02. Twose of Tiverton Ltd makes no warranty as to the design, capability, capacity or suitability for use of the goods.
- 3.03. Except as provided herein, Twose of Tiverton Ltd shall have no liability or responsibility to the purchaser or any other person or entity with respect to any liability, loss, or damage caused or alleged to be caused directly or indirectly by the goods including, but not limited to, any indirect, special, consequential, or incidental damages resulting from the use or operation of the goods or any breach of this warranty. Notwithstanding the above limitations and warranties, the manufacturer's liability hereunder for damages incurred by the purchaser or others shall not exceed the price of the goods.
- 3.04. No action arising out of any claimed breach of this warranty or transactions under this warranty may be brought more than one (1) year after the cause of the action has occurred.

## **4. MISCELLANEOUS**

- 4.01. Twose of Tiverton Ltd may waive compliance with any of the terms of this limited warranty, but no waiver of any terms shall be deemed to be a waiver of any other term.
- 4.02. If any provision of this limited warranty shall violate any applicable law and is held to be unenforceable, then the invalidity of such provision shall not invalidate any other provisions herein.
- 4.03. Applicable law may provide rights and benefits to the purchaser in addition to those provided herein.





# DECLARATION OF CONFORMITY

*Conforming to EU Machinery Directive 2006/42/EC*

We,

**TWOSE of TIVERTON LIMITED,**  
6 Chinon Court, Lower Moor Way,  
Tiverton Business Park, Tiverton, Devon, EX16 6SS, UK

*Hereby declare that:*

The Product; Rotary Disc Mower

Product Code; TSIP

Serial No. & Date ..... Type .....

Manufactured in; Slovenija

Complies with the required provisions of the Machinery Directive 2006/42/EC  
The machinery directive is supported by the following harmonized standards;

- BS EN ISO 14121-1 (2007) Safety of machinery - Risk assessment, Part 1: Principles Part 2: practical guide and examples of methods.
- BS EN ISO 12100-1 (2010) Safety of machinery - Part 1: Basic terminology and methodology Part 2: Technical principles.
- BS EN 349(1993)+ A1 (2008) Safety of machinery - Minimum distances to avoid the entrapment with human body parts.
- BS EN 953 (1998) Safety of machinery - Guards General requirements for the design and construction of fixed and movable guards.
- BS EN 982(1996)+ A1 (2008) Safety requirements for fluid power systems and their components. Hydraulics

Signed ..... *Responsible Person*  
**CHRISTIAN DAVIES** on behalf of **TWOSE of TIVERTON LIMITED**

**Status:** General Manager

**Date:** May 2011





# LIST OF CONTENTS

Page No.

## **Operation Section**

Technical Data	1
Machine Description	2
Safety Information	3
Safety Decals	5
Tractor Requirements	6
Attachment to Tractor	7
Setting of Side Position	7
Hitch Adjustment	8
PTO Shaft	9
Clutch Installation & Maintenance	9
Hydraulic Connections	10
Transport Lock	10
Transport & Work Positions	11
Mowing Instructions	12
Breakback System	13
General Maintenance	14
Storage	20

## TECHNICAL DATA

<b>SPECIFICATION</b>	<b>DS270S</b>	<b>DS300S</b>	<b>DS340S</b>
Attachment (3-point hitch)	<i>Cat. II</i>	<i>Cat. II</i>	<i>Cat. II</i>
Working width	<i>2.47m</i>	<i>2.90m</i>	<i>3.42m</i>
Weight	<i>730kg</i>	<i>790 kg</i>	<i>850kg</i>
Working speed	<i>Up to 18km/h</i>	<i>Up to 18km/h</i>	<i>Up to 18km/h</i>
Maximum PTO speed	<i>1000RPM</i>	<i>1000RPM</i>	<i>1000RPM</i>
Disc rotation speed	<i>3000RPM</i>	<i>3000RPM</i>	<i>3000RPM</i>
No. of discs	<i>6</i>	<i>7</i>	<i>8</i>
No. of knives	<i>12</i>	<i>14</i>	<i>16</i>
Basic drive type	<i>Driveshaft</i>	<i>Driveshaft</i>	<i>Driveshaft</i>
Disc drive type	<i>Gear</i>	<i>Gear</i>	<i>Gear</i>
Minimum power requirement	<i>50HP</i>	<i>60HP</i>	<i>70HP</i>

## MACHINE SERIAL NUMBER PLATE

All machines will have a serial number plate fitted to them stating; the machine model, serial number of the machine, and the machine's weight. When ordering replacement parts or requesting service information always quote the machine model and serial number as stated on its serial number plate.

## **DESCRIPTION**

TwoSE DS Series Disc Mowers are three-point linkage tractor mounted agricultural implements specifically designed for the mowing of grass and clover on even terrain. Depending on the particular model, machines have either 6, 7 or 8 'cutterbar mounted' rotating discs each of which is equipped with 2 cutting knives, the discs of the machine are shaft driven with slip clutch protection. Machines are fitted with either a mechanical breakback system or optional hydraulic breakback. All machines are equipped with a hydraulic 'fold up' system for transportation.















These machines must only be used to perform the designated task for which they were designed. Use of these machines for any other function may cause damage to the machine and possible injury to the operator or other persons.









## SAFETY INFORMATION

---

In the interest of safety it is important that great care is adopted at all times during the attachment, transportation, operation and main tenance of this machine . Both the owner and the operator of the machine should read and understand the following section to ensure the safety of themselves and all other persons who enter into the close proximity of these machines.

---

-  In addition to the instructions stated here al ways abide by general safety and accident regulations.
-  Safety and warning decals placed on the mach ine give important instructions for safe work - take them into consideration for your safety and the safety of others.
-  While driving on public roads always abide by traffic signs and road regulations.
-  Familiarise yourself with the controls and fu nctions of the machine and practice them in a safe location before attempting to start work.
-  Never approach this machine whilst it is wo rking or r unning – s witch off the machine and wait until it has stopped fully before approaching.
-  Do not wear loose fitting clothes in the vicinity of this machine - clothes should fit tight to the user's body.
-  Check no one is near to, or on, the machine before attempting to start or transport it. Ensure your visibility is kept clear at all times.
-  Never permit anyone to ride on this machine.
-  Implements should always be attached accordi ng to the manufacturer's i nstructions and fastened correctly to the prescribed devices using the correct components.
-  When disconnecting t he machine from the tracto r select a firm l evel site and use the support leg.
-  Take care when connecting or disconnecting the implement to the tractor – keep onlookers at a safe distance.
-  Ensure controls for the machine are po sitioned s uch that the machin e cannot accidentally be started during transport.
-  For transportation on the r oad, prepare and secure the machine acc ording to the manufacturer's instructions.
-  Never leave the driver seat whilst the tractor or the machine is running.

-  Always adjust the driving speed to suit the driving conditions. Avoid fast turning when driving uphill, downhill or across a slope. Braking performance and turning ability will be affected when implements are connected or mounted to the tractor - allow extra time for turning and braking.
-  Never attempt to operate a machine without its safety devices fitted or incorrectly secured.
-  Ensure all bystanders are kept at a safe distance from a moving or working machine.
-  Even when the machine is unattached some hydraulic or mechanical components on the machine are able to be rotated or moved by hand and are therefore capable of causing injury to fingers or hands due to trapping. Wherever possible secure these components during storage to prevent accidental injuries.
-  Always place the machine in a safe position before leaving the tractor - lower the implement completely, switch off the engine and remove the ignition key.
-  Never permit anyone between the machine and the tractor whilst either is working or when the machine is in a raised position.
-  Only use machines on a tractor that is capable of taking its weight - use weights or ballast as required ensuring stability of the unit.
-  Be aware at all times of the width, height and length of any machinery you are operating – especially when transporting on the public highway or near obstructions.
-  Ensure the work area is clear of obstructions before starting work – clear stones, wire, glass or any other dangerous objects from the work site before attempting to start work.

---

**Although the information given here covers a wide range of safety subjects it is impossible to predict every eventuality that can occur under differing circumstances whilst operating this machine. No advice given here can replace 'good common sense' and 'total awareness' at all times but will go a long way towards the safe use of your TwoSE machine.**

---

## SAFETY DECALS



1. **WARNING!** Always 'Read the Operator Manual'.
2. **DANGER!** Pinch & Crush Zone – Keep hands and limbs clear whilst machine is working.
3. **DANGER!** Wait until machine has stopped completely before approaching.
4. **DANGER!** Keep clear of mower knife area whilst tractor or machine is running.
5. **DANGER!** Keep clear of machine whilst tractor or machine is running.
6. **WARNING!** Switch off tractor engine & remove key before performing maintenance or repair.
7. **DANGER!** Keep clear of danger area between tractor and machine.
8. **DANGER!** Keep clear of raised machine.
9. **WARNING!** Maximum RPM – 540RPM machines only.
10. **WARNING!** Maximum RPM – 1000RPM machines only.
11. **INFORMATION!** Blade Information
12. **INFORMATION!** Check tightness of nuts & bolts every couple of working hours.

### TRACTOR REQUIREMENTS

The tractor to which this machine is to be fitted must meet the following criteria:

- 3-point linkage connection – Cat. II or Cat. III.
- Minimum tractor power requirement of:
  - 50HP for DS270S Models
  - 60HP for DS300S Models
  - 70HP for DS340S Models
- PTO shaft speed: Maximum 1000 RPM (*Option 540 RPM*)
- Hydraulic service connection.

### ADJUSTMENT OF THE MACHINE TO THE TRACTOR WHEEL TRACK

The 3-point linkage pins should be set in a position that permits the machine to be attached to the tractor as close as possible whilst still allowing the full working width of the machine to remain outside of the tractor's wheel track. After adjustment fasten the hydraulic arms with check chains or bars – refer to diagram opposite.

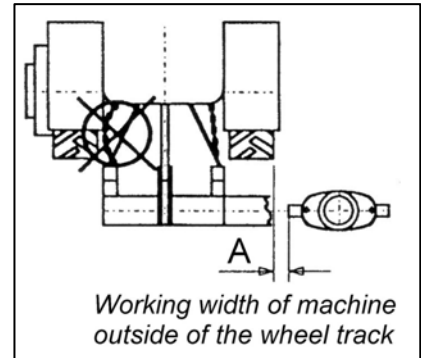

## Attachment to Tractor

Select a firm level site on which to attach the mower to the tractor.

Reverse the tractor up to the machine positioning the linkage arms (1) at a suitable height for attachment to the machine, secure in position with locking pins (2).

Fit top link (3) and secure top link pin with locking pin (4).

**Note:** The top link should be adjusted to an angle of at least 3° greater than the lower links arms – refer to diagram below

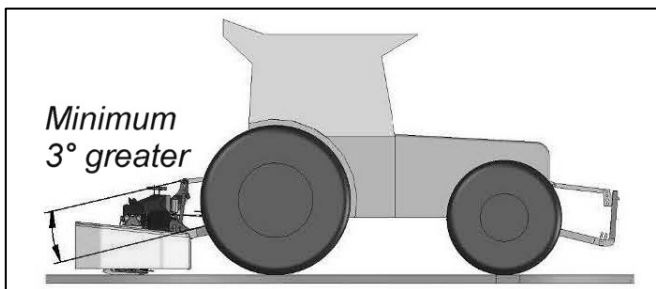
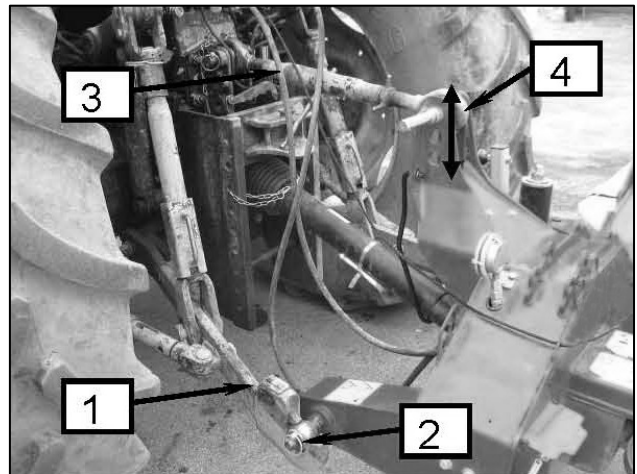

Raise support leg (5) into the stowed position and secure in place with its lock pin (6).

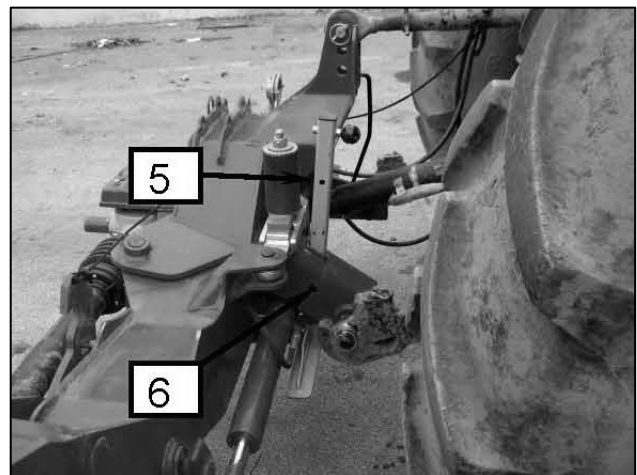

## Setting of Side Position

The working position of the machine (side position) is set by sideways adjustment of the lower link arms to a point where the cutting area of the machines is just beyond the tractor wheel on its working side – see illustrations below.

Shift the mower sideways on the lower link arms (2) to achieve the required distance (A), secure in position with stabiliser arms (3).

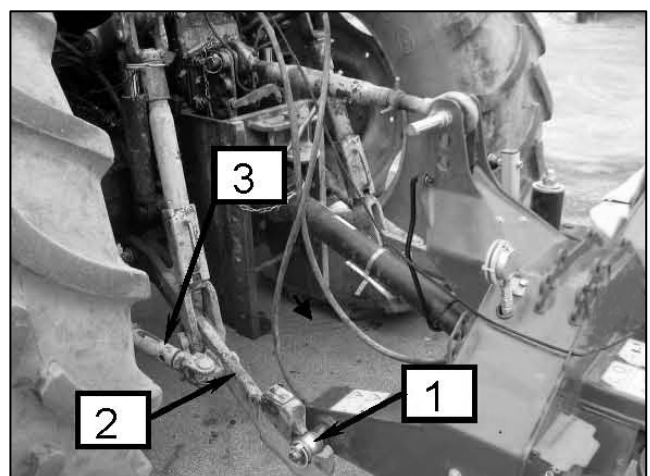
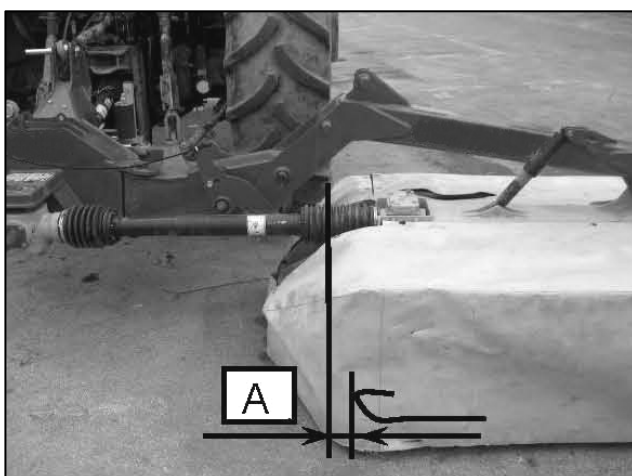



### Transverse Hitch Adjustment

Adjust linkage drop arms (2) on adjustment nuts (1) so the hitch is parallel to the ground when the machine in the work position.

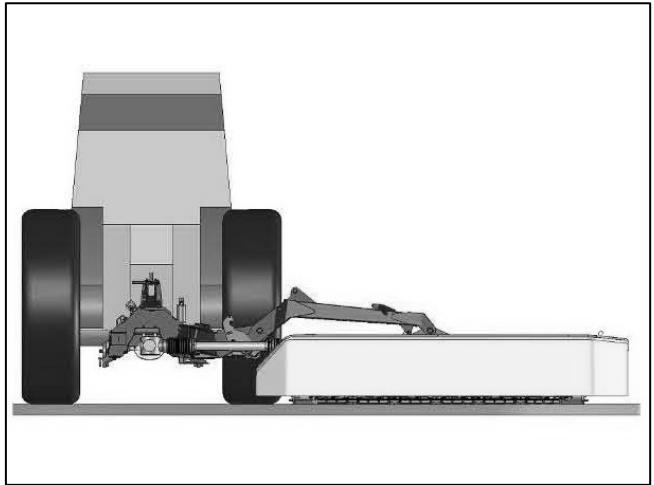
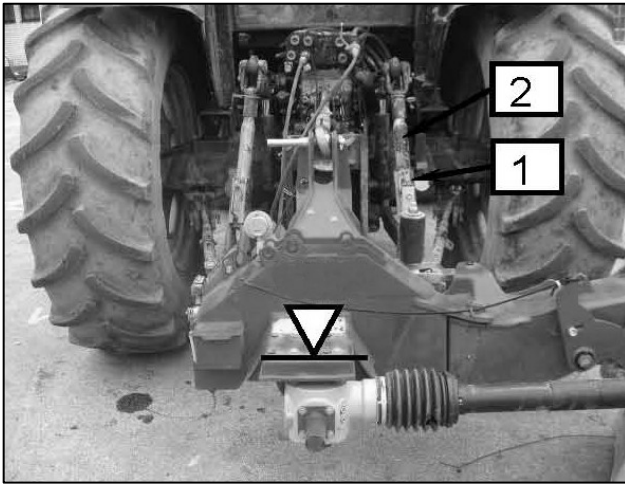

### Parallel Hitch Adjustment & Cutting Height

Parallel adjustment of the machine is achieved via adjuster nut (3) of the top link (2), the correct position is with the machine angled forwards by 2° - this can be gauged by positioning the machine so the safety curtain is just clear of the ground, the bottom of the curtain (1) will be equidistant to the ground when the machine is tilted forward by the required 2°. At this inclination the cutting height of the machine will be approx. 50 – 55mm.

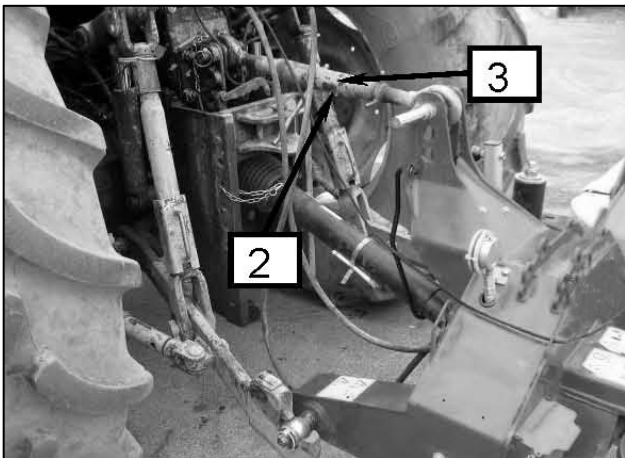

**PTO shaft**

On initial attachment the PTO shaft will need to be measured and adjusted to suit the tractor used. Measure the PTO shaft and cut to the dimension shown - see diagram opposite.

**Slip Clutch must always be fitted to the machine end of the driveshaft.**

The finished length of the PTO shaft should be 75mm (3") less than the measured distance 'A' - between the tractor shaft and gearbox stub shaft to enable correct fitting.

*Note: For subsequent use with different tractors measure again – there must be a minimum shaft overlap of 150mm (6").*

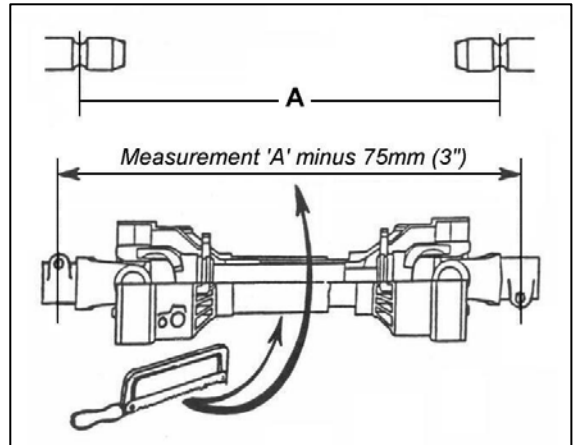

Always secure the PTO guards with torque chains to prevent them from rotating with the shaft. Check to ensure the shaft does not contact or foul tractor or machine components during normal operation - failure to observe this can result in damage to the tractor and/or machine.

**Clutch Installation & Maintenance**

On initial use of the clutch and after storage it is necessary to restore the condition of the friction surfaces and apply full load to the discs using the following procedure:

- Install the device onto the input shaft of the machine and tighten fastenings.
- With the tractor engine running at idle speed, engage tractor PTO for 2-3 seconds to make the clutch slip. *Do not allow the clutch to slip for longer periods as this may cause damage to the linings.* If the clutch fails to slip after 2 or 3 attempts it will need to be disassembled and the contact surfaces cleaned. In the case of a 'used' machine check for damaged components and replace if required.
- Unscrew the socket head bolts completely – this will restore the spring load to the clutch for proper operation.
- At the end of the season, or prior to storage of the machine, tighten the socket head bolts and store the clutch in a clean dry environment.

### Hydraulic Connections

Connect hoses to the tractor's hydraulic system. The machine will require 2 connections (supply & return) for the machine fold ram circuit and for machines equipped with the optional hydraulic breakback an additional hydraulic supply will be required.

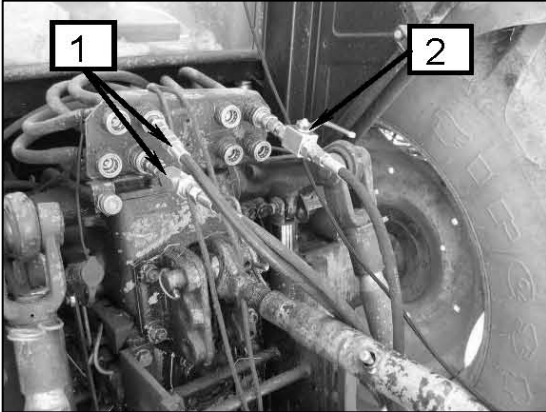

- 1.) Supply & Return for machine fold ram circuit.
  - 2.) Hydraulic breakback supply. \*
- \* Machines fitted with hydraulic breakback option only

### Transport Locking Mechanism

Route the operation cord for the transport locking mechanism (2) into the tractor cab (1) – ensure sufficient slack is retained in the cord to avoid accidental operation of the mechanism.

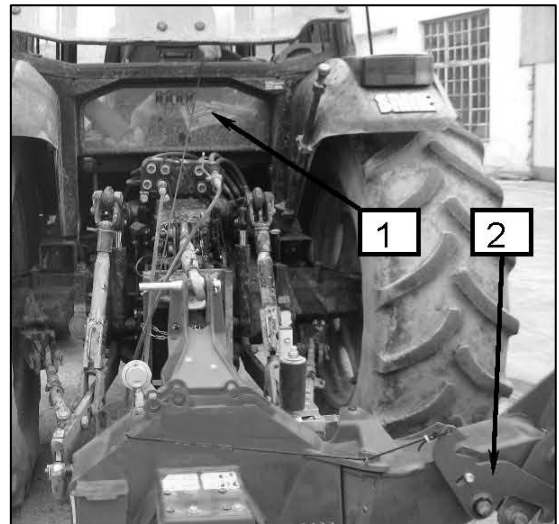

### Ballast

Add front end weights to the tractor if required to increase stability of the unit for both transportation and work. Refer to tractor manufacturer's handbook for advice on ballasting.

### Moving into Transport Position

The procedure for moving the machine into transport position is as follows:

- Set the protection bar (4) into its transport position.
- Pull cord to release the transport lock mechanism (2).
- Raise the cutterbar (1) by operation of the hydraulic fold ram.
- Retain tension on transport locking cord until the machine is fully folded into the upright position – release cord to lock the mechanism (3). This will keep the machine in position.
- Raise machine on the tractor's 3 point linkage to a suitable height for transportation.

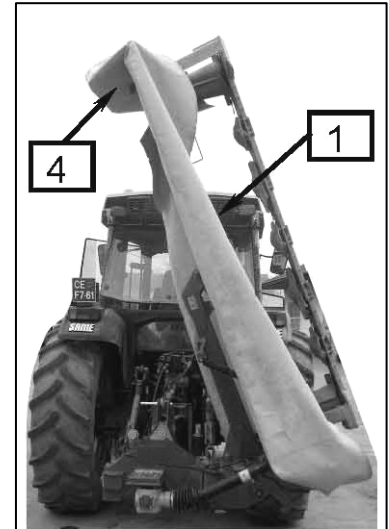

### Moving into Work Position

The procedure for moving the machine into work position is as follows:

- Raise cutterbar slightly by operation of the fold ram enough only to take tension off the transport lock mechanism.
- Pull cord to release transport lock (2).
- Lower cutterbar (1) using hydraulic fold ram.
- Set tractor hydraulics to 'float' mode.
- Lower mower to working height.
- Set protection bar (4) into work position.

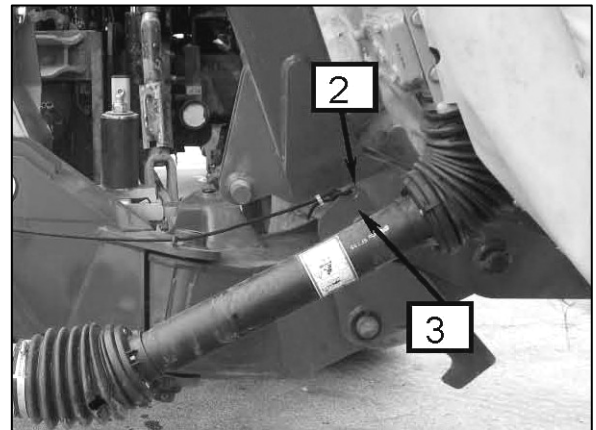

The working height of the machine on the tractor's linkage is correct when the cutting unit is at its optimum working height and position with the PTO shaft parallel to the ground. Raise or lower the machine on the linkage to suit this condition.

## Instructions for Safe Mowing

- Always ensure that each disc is fitted with 2 knives, either new or equally worn.
- Always replace damaged or worn blades, knives, and knife holders immediately – never attempt to operate the machine with any of these components in a damaged or overly worn condition.
- Stop the machine immediately if an increase in noise or vibration is experienced – continue work only when the reason for the disturbance has been investigated and resolved. *Ensure both the machine and the tractor's engines are switched off before nearing the mower to investigate.*
- Only operate the machine at the correct PTO speed.

## Regulation of Cutting Height

The cutting height can be regulated by the top link.

Correct adjustment is with the position of the mower inclined forwards by 2°. If the mower is inclined backwards the cutting height will be higher and therefore quantity of forage reduced.

## Mowing Instructions

- Allow the mower to reach its maximum permitted PTO speed before entering it into the grass to cut and keep the machine at this speed for the duration of the mowing to ensure a clean cut.
- Select a gear that will enable best mowing according to the ground conditions.
- Replace worn knives – sharp knives produce a cleaner more efficient cut.

## Safety Breakback

The mower has a safety system which allows the machine to automatically breakback to a position behind the tractor if contact with a heavy or fixed obstacle is made, thus preventing, or reducing, damage to the machine. When the mower 'breaks back' the tractor should be stopped immediately and reversed backwards to return the mower to the work position - the obstacle should then be removed or avoided to allow continuation of mowing. NOTE: The 'break back' system only operates when the machine is moving in a forwards direction.

Depending on the specification of the machine the break back system will either be mechanically operated by utilisation of a spring system or hydraulically operated via a hydraulic ram and accumulator.

## Mechanical Breakback System

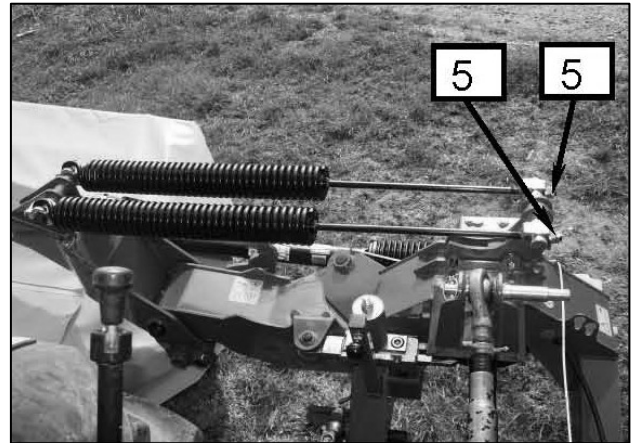
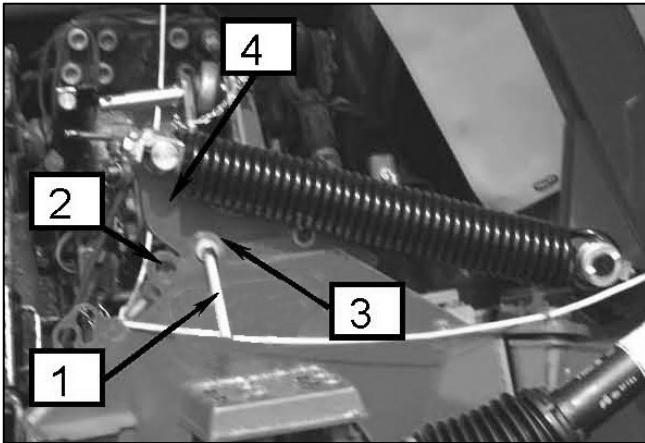

### Activation

With the machine in the transportation position remove pin (1) from hole (2) and relocate it in hole (3) – breakback is now activated and the machine can be lowered into the work position.

### De-activation

Raise mower into transport position, remove pin (1) from hole (3) and relocate it in hole (2) – breakback is now de-activated.

## Hydraulic Breakback System (Option)

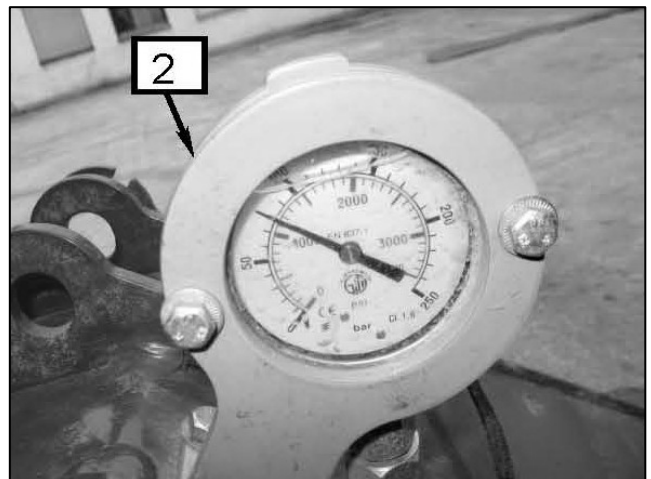
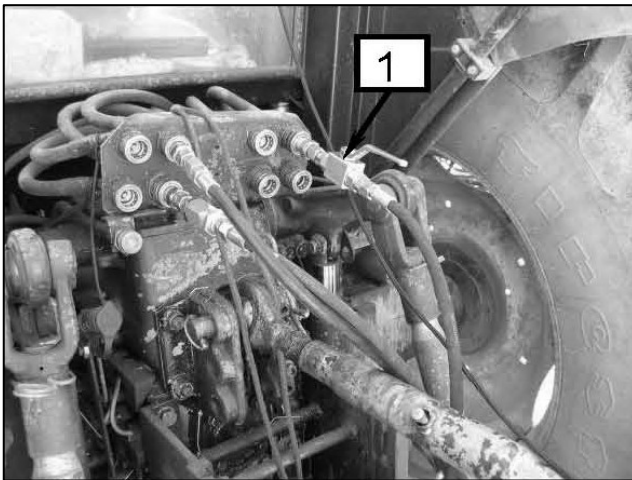

### Pressurising the Circuit

Open valve tap (1) switch on tractor's hydraulic control and pressurise the system to a level of 85-95 bar measure by the manometer (2). Close valve tap (1) when correct pressure is achieved. Higher pressure may be required in conditions where high forward working speed is used.

### De-pressurising the Circuit

Open valve tap (1) to release the pressure from the system.

**WARNING:** Always release the pressure the circuit before attempting to remove the hydraulic hose from the tractors connection.

### Working the Machine

Flexibility of the machine allows for working on inclines of  $\pm 15^\circ$ . Extended working periods at maximum angles should however be avoided as this can increase wear on gear components.

Be aware that the position and movement of the cutterbar whilst in motion can dramatically change the driving characteristics of the tractor, especially on inclines. Caution must be adopted at all times but additional care should be taken when:

- Making a sharp left turn with the machine raised in the transport position.
- Driving across an incline with the cutterbar raised on the downward side.
- Lifting the cutterbar positioned on the downward side of an incline.
- Driving on rough terrain – *keep speed to a minimum.*

**WARNING:** Failure to observe these points can result in risk of overturning the tractor.

### Safety Clutch Operation

The machine has a built in safety clutch which will 'slip' if the cutting head comes into contact with an immovable or heavy object. Whenever this occurs forward travel should be halted immediately and the cutterbar raised clear of the object allowing the clutch to cease slipping and start driving the cutting unit again allowing work to continue – at this point the operator should manoeuvre the machine around the obstruction. If contact with an object is severe the unit should be switched off and inspected to check for possible damage. If damage has occurred do not continue using the machine until it has been repaired correctly.

### Blade Replacement

The blades of the mower are either left or right cutting and therefore must only be mounted on one of the discs that rotates in the same cutting direction – blades are marked with their cutting direction for ease of identification.

The life expectancy of the blades will be determined by the ground surface that you are mowing – stony ground will cause damage to the blades and therefore reduce their life expectancy.

Replacement of the blades (A) is by removal of their fixing nut (B) and blade holder (C) as illustrated in the diagram opposite. When replacing the blades it is always advisable to renew the fixing nut (B) at the same time.

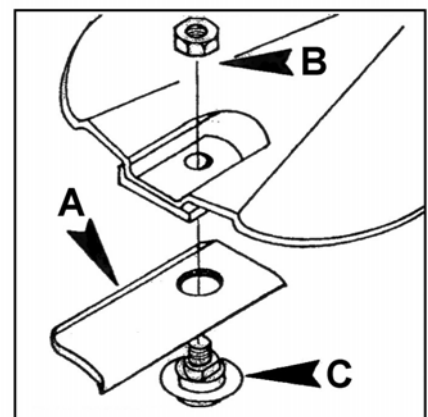

**WARNING:** When removing and replacing discs take care to replace the disc in the correct position in relation to its neighbouring disc so that the blades do not come into contact with each other.

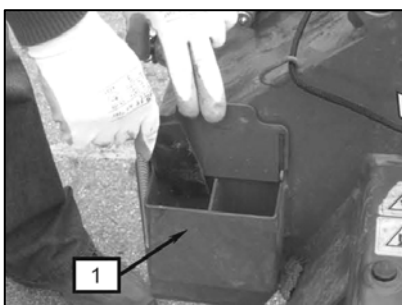

1. Blade Storage Box

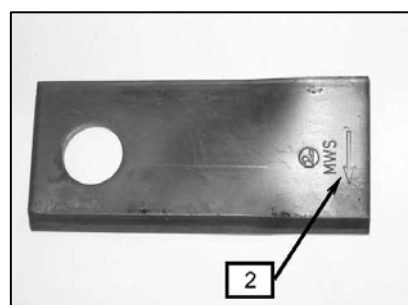

2. Note cutting direction on blade

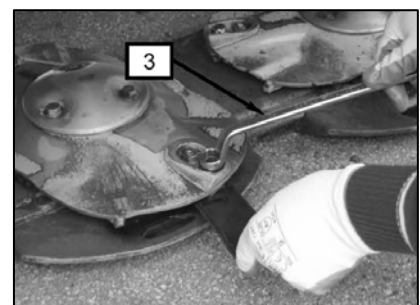

3. Torque blades to 125 Nm.

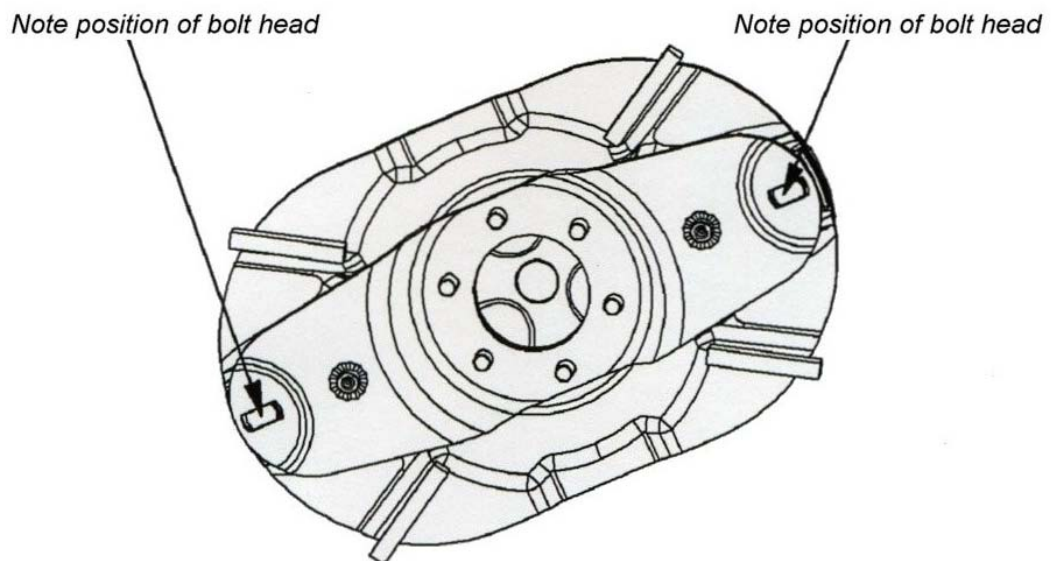
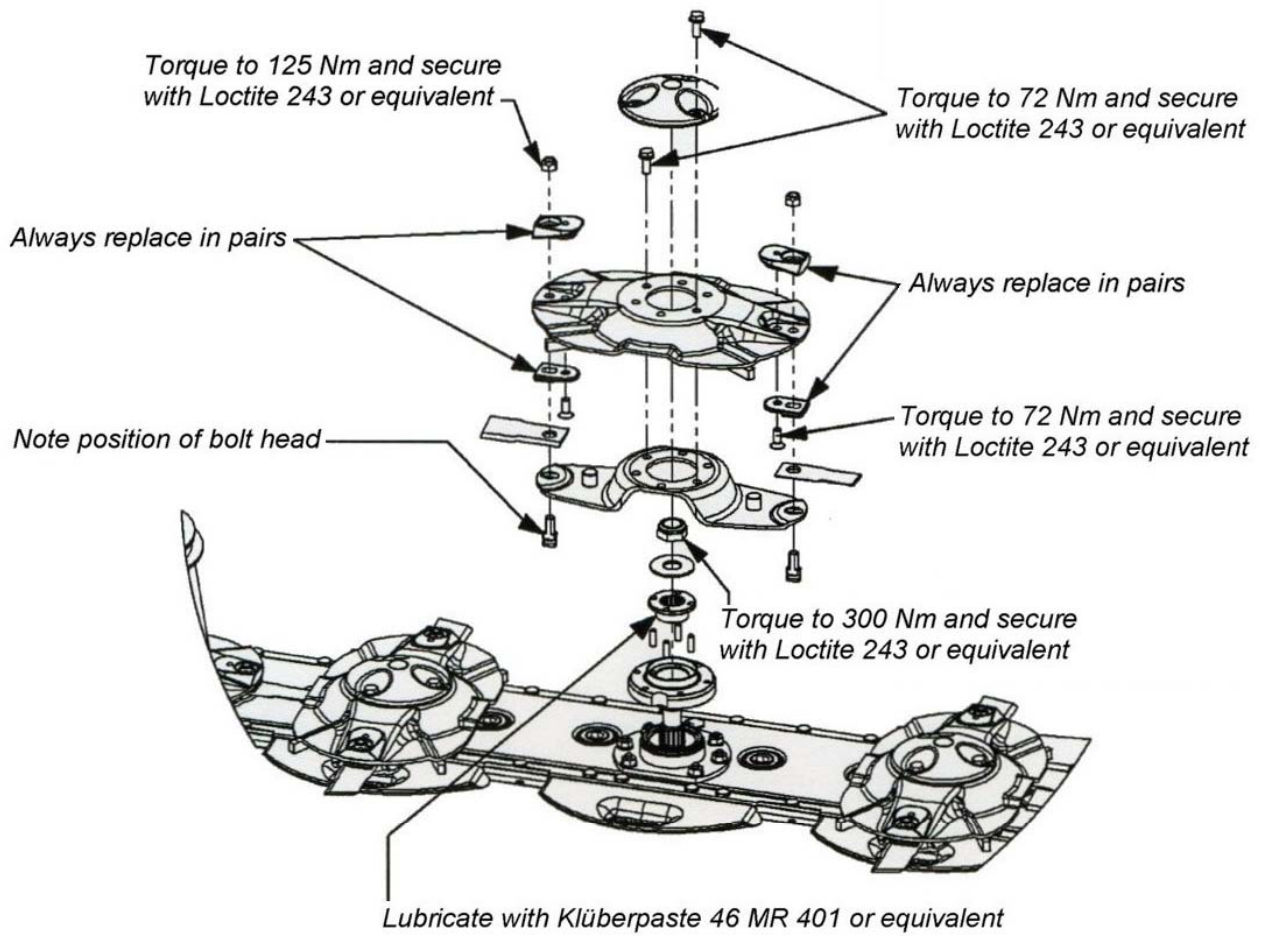



### Replacing the Protective Curtain

The protective curtain should be inspected regularly for signs of wear or damage – if it becomes excessively worn or damaged to a point where it no longer offers protection the machine should not be used until it has been repaired or replaced.

The illustrations opposite show the curtain attachment locations. The dismantling sequence for removal of the curtain is 4, 1, 2, 3.

For curtain replacement the sequence is reversed.

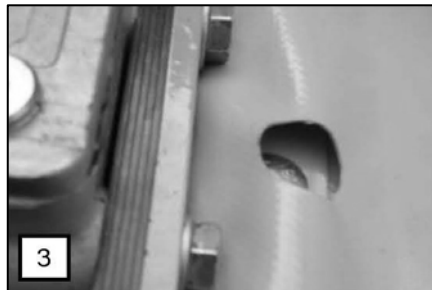
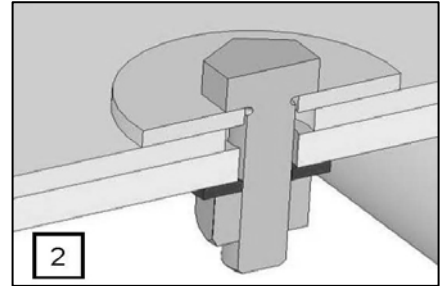
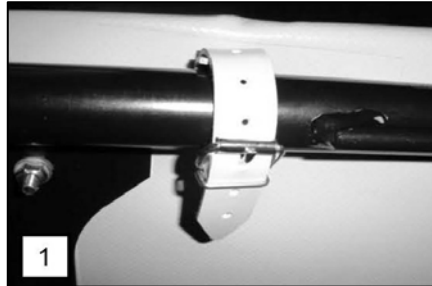

### Lubrication

The photo below indicates the location of the lubrication points on the machine.

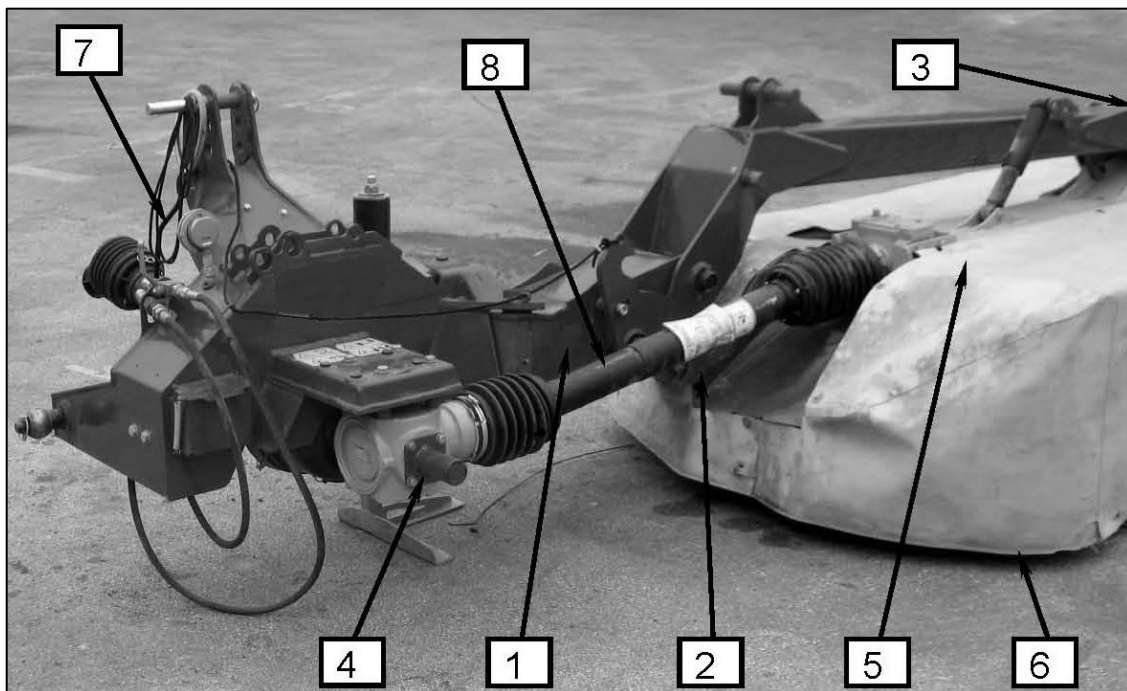

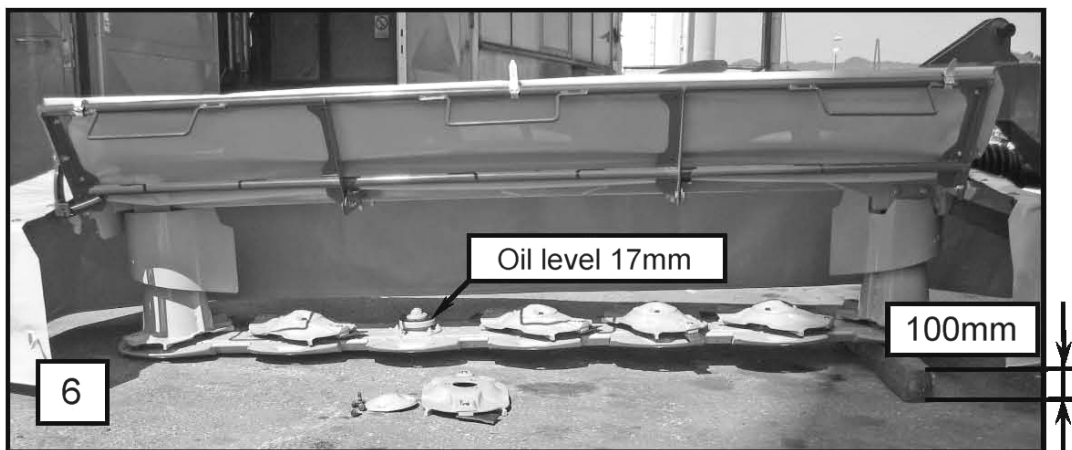
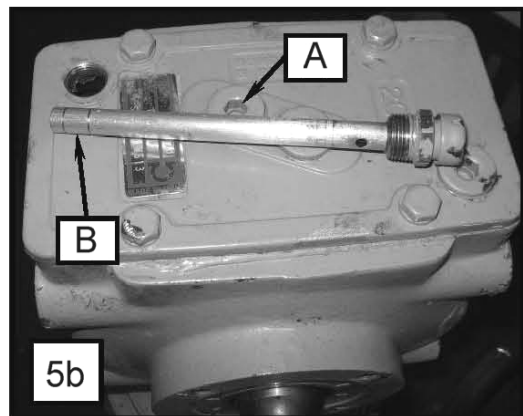
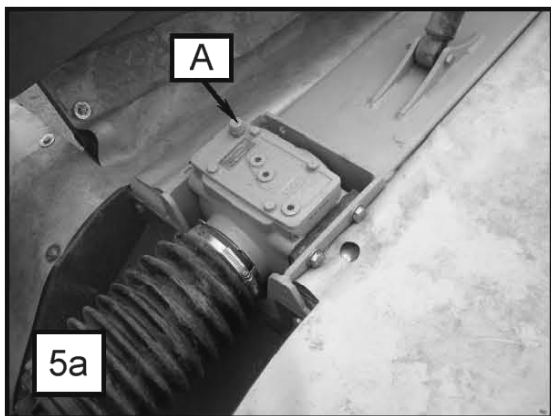
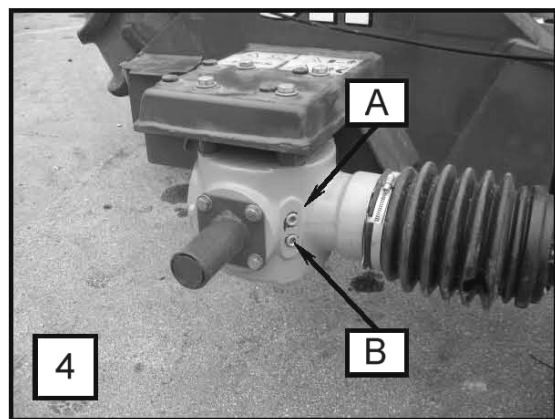
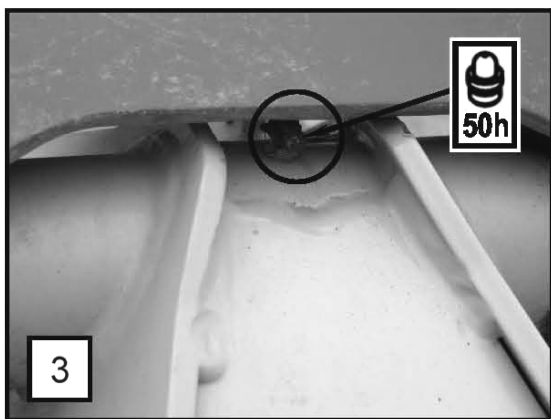
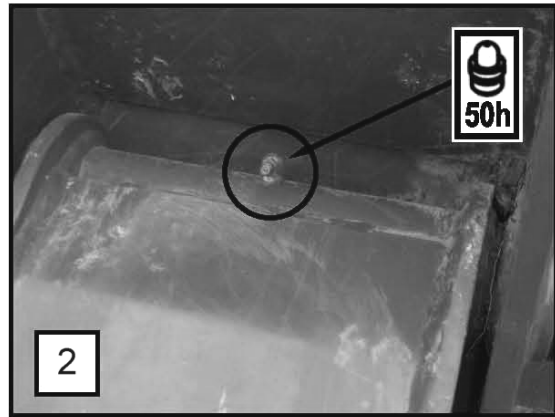
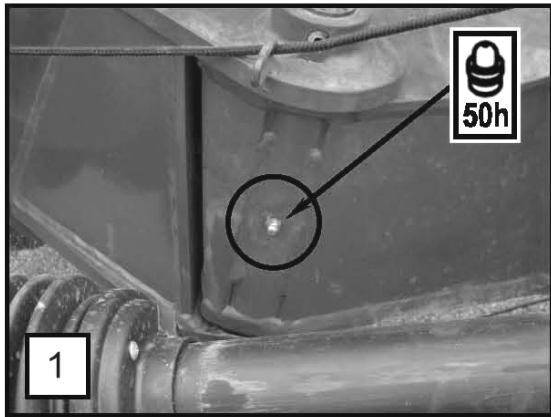

Grease PTO shaft at the locations and time intervals stated on the illustration below:

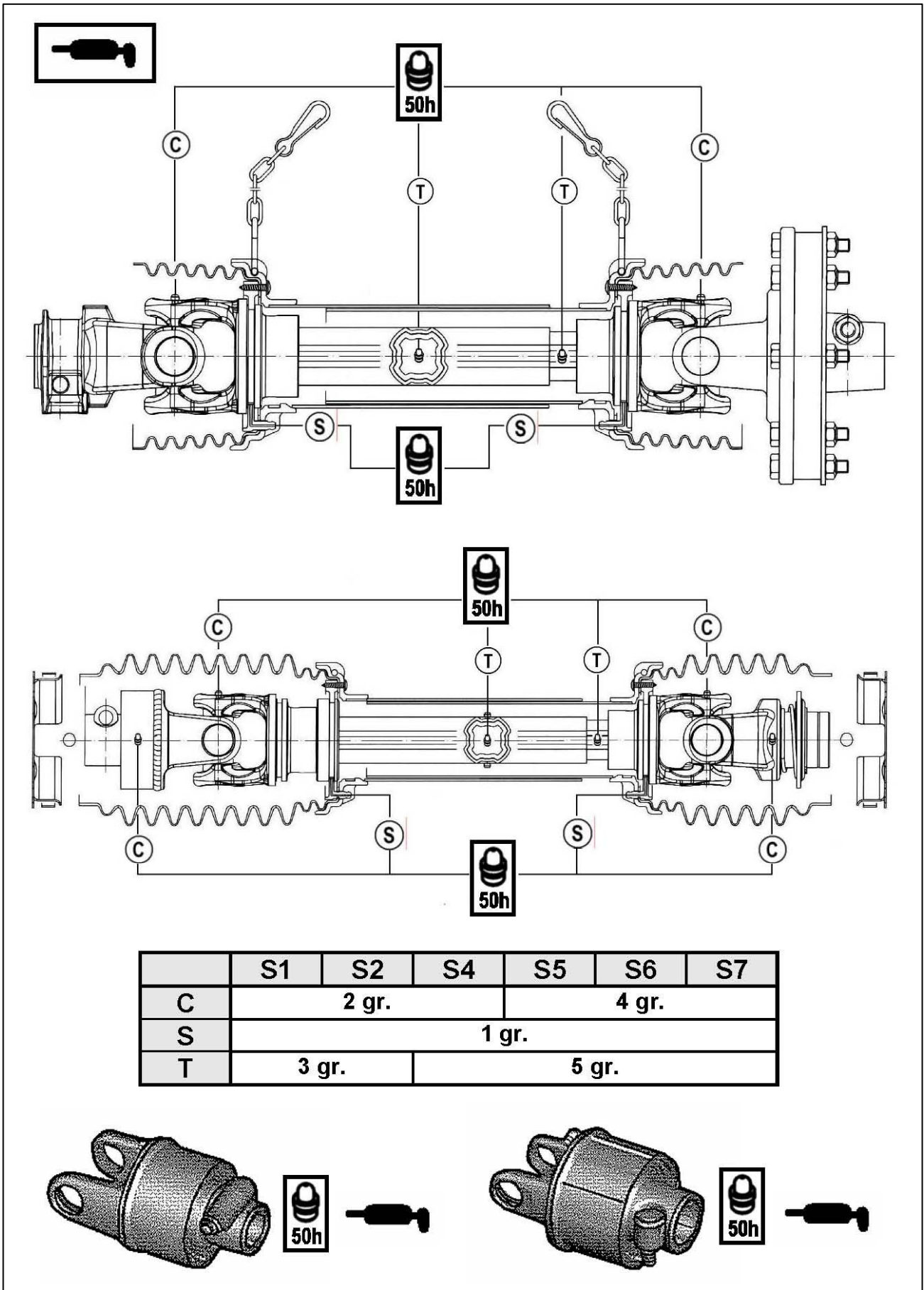

### Lubrication Information

Ref.	Driving Gear	Lubricant	Change Criteria	Filling Criteria
4	Edge Gear	SAE90	Fill via hole 'A'	Until oil runs from hole 'B'
5	Bar Gear	SAE90		Measure level with screw 'A' - oil level shows between marks indicated 'B'
6	Mower Manger	SAE90	3.5L	By procedure stated below

### Mower Bar Oil Level Checking Procedure

- Park on a level site and run the machine until oil is warm.
- Raise the mowing bar to approx. 100mm and prop the right hand side using a 4" wooden block or lath.
- Lower the mowing bar so the left hand side is resting on the ground (with the right hand side still raised on the wooden prop).
- Check oil level through the hole using a dipstick – dip until it reaches the floor of the mowing bar. The required oil level should be approximately 17mm.

NOTE: If for any reason it is not possible to measure the oil in the mower bar using a dipstick the oil should be drained fully and replaced with 3.5L of fresh oil.

## Storage

Wherever possible for extended storage periods the machine should be placed in a safe clean dry environment to protect it from the elements.

Prior to storage the machine:

- Thoroughly clean and dry the machine both inside and out – *use of a high pressure washer is not recommended as these can easily cause damage to paintwork.*
- Check flexible parts and joints – dismantle, clean and check wear levels. Replace parts if required to ensure the machine is ready for the next seasons work.
- Lubricate and grease the machine.
- Grease the PTO shaft bearings.
- Coat vulnerable areas of the machine with grease to protect it from corroding.

## Removing from Storage

- Remove protective coatings of grease.
- Re-lubricate the machine to eliminate condensation from bearings.
- Check tyre pressures.
- Check lubricant levels and refill or top up if required.
- Check tightness of nuts, bolts and screws.

