



Twose Series  
**BALEHANDLER**

Models: ABH04 / ABH04E8

Operator Manual

Publication 5290

June 2016

# IMPORTANT

## VERIFICATION OF WARRANTY REGISTRATION



### DEALER WARRANTY INFORMATION & REGISTRATION VERIFICATION

It is imperative that the selling dealer registers this machine with McConnel Limited before delivery to the end user – failure to do so may affect the validity of the machine warranty.

To register machines go to the McConnel Limited web site at [www.mcconnel.com](http://www.mcconnel.com), log onto 'Dealer Inside' and select the 'Machine Registration button' which can be found in the Service Section of the site. Confirm to the customer that the machine has been registered in the section below.

Should you experience any problems registering a machine in this manner please contact the McConnel Service Department on 01584 875848.

#### Registration Verification

Dealer Name: .....
Dealer Address: .....
Customer Name: .....
Date of Warranty Registration: ...../...../..... Dealer Signature: .....

#### NOTE TO CUSTOMER / OWNER

*Please ensure that the above section above has been completed and signed by the selling dealer to verify that your machine has been registered with McConnel Limited.*

**IMPORTANT:** During the initial 'bedding in' period of a new machine it is the customer's responsibility to regularly inspect all nuts, bolts and hose connections for tightness and re-tighten if required. New hydraulic connections occasionally weep small amounts of oil as the seals and joints settle in – where this occurs it can be cured by re-tightening the connection – *refer to torque settings chart below*. The tasks stated above should be performed on an hourly basis during the first day of work and at least daily thereafter as part of the machines general maintenance procedure.

**CAUTION: DO NOT OVER TORQUE HYDRAULIC FITTINGS AND HOSES**

#### TORQUE SETTINGS FOR HYDRAULIC FITTINGS

HYDRAULIC HOSE ENDS		
BSP	Setting	Metric
1/4"	18 Nm	19 mm
3/8"	31 Nm	22 mm
1/2"	49 Nm	27 mm
5/8"	60 Nm	30 mm
3/4"	80 Nm	32 mm
1"	125 Nm	41 mm
1.1/4"	190 Nm	50 mm
1.1/2"	250 Nm	55 mm
2"	420 Nm	70 mm

PORT ADAPTORS WITH BONDED SEALS		
BSP	Setting	Metric
1/4"	34 Nm	19 mm
3/8"	47 Nm	22 mm
1/2"	102 Nm	27 mm
5/8"	122 Nm	30 mm
3/4"	149 Nm	32 mm
1"	203 Nm	41 mm
1.1/4"	305 Nm	50 mm
1.1/2"	305 Nm	55 mm
2"	400 Nm	70 mm

# WARRANTY POLICY

## WARRANTY REGISTRATION

All machines must be registered, by the selling dealer with McConnel Ltd, before delivery to the end user. On receipt of the goods it is the buyer's responsibility to check that the Verification of Warranty Registration in the Operator's Manual has been completed by the selling dealer.

### 1. LIMITED WARRANTIES

- 1.01. *All machines supplied by McConnel Ltd are warranted to be free from defects in material and workmanship from the date of sale to the original purchaser for a period of 12 months, unless a different period is specified.*
- 1.02. *All spare parts supplied by McConnel Ltd and purchased by the end user are warranted to be free from defects in material and workmanship from the date of sale to the original purchaser for a period of 6 months. All parts warranty claims must be supported by a copy of the failed part invoice to the end user. We cannot consider claims for which sales invoices are not available.*
- 1.03. *The warranty offered by McConnel Ltd is limited to the making good by repair or replacement for the purchaser any part or parts found, upon examination at its factory, to be defective under normal use and service due to defects in material or workmanship. Returned parts must be complete and unexamined. Pack the component(s) carefully so that any transit damage is avoided. All ports on hydraulic items should be drained of oil and securely plugged to prevent seepage and foreign body ingress. Certain other components, electrical items for example, may require particular care when packing to avoid damage in transit.*
- 1.04. *This warranty does not extend to any product from which McConnel Ltd's serial number plate has been removed or altered.*
- 1.05. *This warranty does not apply to any part of the goods, which has been subjected to improper or abnormal use, negligence, alteration, modification, fitment of non-genuine parts, accident damage, or damage resulting from contact with overhead power lines, damage caused by foreign objects (e.g. stones, iron, material other than vegetation), failure due to lack of maintenance, use of incorrect oil or lubricants, contamination of the oil, or which has served its normal life. This warranty does not apply to any expendable items such as blades, belts, clutch linings, filter elements, flails, flap kits, skids, soil engaging parts, shields, guards, wear pads, pneumatic tyres or tracks.*
- 1.06. *Temporary repairs and consequential loss - i.e. oil, downtime and associated parts are specifically excluded from the warranty.*
- 1.07. *Warranty on hoses is limited to 12 months and does not include hoses which have suffered external damage. Only complete hoses may be returned under warranty, any which have been cut or repaired will be rejected.*
- 1.08. *Machines must be repaired immediately a problem arises. Continued use of the machine after a problem has occurred can result in further component failures, for which McConnel Ltd cannot be held liable, and may have safety implications.*
- 1.09. *If in exceptional circumstances a non McConnel Ltd part is used to effect a repair, warranty reimbursement will be at no more than McConnel Ltd's standard dealer cost for the genuine part.*
- 1.10. *Except as provided herein, no employee, agent, dealer or other person is authorised to give any warranties of any nature on behalf of McConnel Ltd.*
- 1.11. *For machine warranty periods in excess of 12 months the following additional exclusions shall apply:*
  - 1.11.1. *Hoses, exposed pipes and hydraulic tank breathers.*
  - 1.11.2. *Filters.*
  - 1.11.3. *Rubber mountings.*
  - 1.11.4. *External electric wiring.*
  - 1.11.5. *Bearings and seals.*

- 1.12. *All service work, particularly filter changes, must be carried out in accordance with the manufacturer's service schedule. Failure to comply will invalidate the warranty. In the event of a claim, proof of the service work being carried out may be required.*
- 1.13. *Repeat or additional repairs resulting from incorrect diagnosis or poor quality previous repair work are excluded from warranty.*

***NB Warranty cover will be invalid if any non-genuine parts have been fitted or used. Use of non-genuine parts may seriously affect the machine's performance and safety. McConnel Ltd cannot be held responsible for any failures or safety implications that arise due to the use of non-genuine parts.***

## **2. REMEDIES AND PROCEDURES**

- 2.01. *The warranty is not effective unless the Selling Dealer registers the machine, via the McConnel Ltd web site and confirms the registration to the purchaser by completing the confirmation form in the operator's manual.*
- 2.02. *Any fault must be reported to an authorised McConnel Ltd dealer as soon as it occurs. Continued use of a machine, after a fault has occurred, can result in further component failure for which McConnel Ltd cannot be held liable.*
- 2.03. *Repairs should be undertaken within two days of the failure. Claims submitted for repairs undertaken more than 2 weeks after a failure has occurred, or 2 days after the parts were supplied will be rejected, unless the delay has been authorised by McConnel Ltd. Please note that failure by the customer to release the machine for repair will not be accepted as a reason for delay in repair or submitting warranty claims.*
- 2.04. *All claims must be submitted, by an authorised McConnel Ltd Service Dealer, within 30 days of the date of repair.*
- 2.05. *Following examination of the claim and parts, McConnel Ltd will pay, at their discretion, for any valid claim the invoiced cost of any parts supplied by McConnel Ltd and appropriate labour and mileage allowances if applicable.*
- 2.06. *The submission of a claim is not a guarantee of payment.*
- 2.07. *Any decision reached by McConnel Ltd is final.*

## **3. LIMITATION OF LIABILITY**

- 3.01. *McConnel Ltd disclaims any express (except as set forth herein) and implied warranties with respect to the goods including, but not limited to, merchantability and fitness for a particular purpose.*
- 3.02. *McConnel Ltd makes no warranty as to the design, capability, capacity or suitability for use of the goods.*
- 3.03. *Except as provided herein, McConnel Ltd shall have no liability or responsibility to the purchaser or any other person or entity with respect to any liability, loss, or damage caused or alleged to be caused directly or indirectly by the goods including, but not limited to, any indirect, special, consequential, or incidental damages resulting from the use or operation of the goods or any breach of this warranty. Notwithstanding the above limitations and warranties, the manufacturer's liability hereunder for damages incurred by the purchaser or others shall not exceed the price of the goods.*
- 3.04. *No action arising out of any claimed breach of this warranty or transactions under this warranty may be brought more than one (1) year after the cause of the action has occurred.*

## **4. MISCELLANEOUS**

- 4.01. *McConnel Ltd may waive compliance with any of the terms of this limited warranty, but no waiver of any terms shall be deemed to be a waiver of any other term.*
- 4.02. *If any provision of this limited warranty shall violate any applicable law and is held to be unenforceable, then the invalidity of such provision shall not invalidate any other provisions herein.*
- 4.03. *Applicable law may provide rights and benefits to the purchaser in addition to those provided herein.*



# DECLARATION OF CONFORMITY

*Conforming to EU Machinery Directive 2006/42/EC*

We,

**McCONNEL LIMITED**, Temeside Works, Ludlow, Shropshire SY8 1JL, UK

*Hereby declare that:*

The Product; *Tractor Mounted Bale Handling Attachment*

Product Code; *TBAL*

Serial No. & Date ..... Type .....

Manufactured in; *United Kingdom*

Complies with the required provisions of the Machinery Directive 2006/42/EC  
The machinery directive is supported by the following harmonized standards;

- BS EN ISO 12100 (2010) Safety of machinery – General principles for design – Risk assessment and risk reduction.
- BS EN 349 (1993) + A1 (2008) Safety of machinery - Minimum distances to avoid the entrapment with human body parts.
- BS EN 953 (1997) + A1 (2009) Safety of machinery - Guards general requirements for the design and construction of fixed and movable guards.
- BS EN 4413 (2010) Hydraulic fluid power. Safety requirements for systems and their components.

McCONNEL LIMITED operates an ISO 9001:2008 quality management system, certificate number: FM25970.

This system is continually assessed by the;

British Standards Institution (BSI), Beech House, Milton Keynes, MK14 6ES, UK  
BSI is accredited by UK Accreditation Service, accreditation number: UKAS 003.  
The EC declaration only applies if the machine stated above is used in accordance with the operating instructions.

Signed  ..... *Responsible Person*  
*CHRISTIAN DAVIES on behalf of McCONNEL LIMITED*

Status: *General Manager*

Date: *May 2016*

THIS MANUAL IS TO BE HANDED TO THE CUSTOMER BEFORE THE  
MACHINE IS TO BE USED FOR THE FIRST TIME

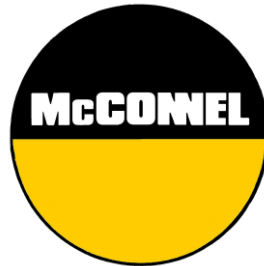

**McCONNEL LIMITED**  
TEMESIDE WORKS  
LUDLOW  
SHROPSHIRE  
SY8 1ND

TELEPHONE:  
01584 873131

*All dimensions and capacities mentioned in this book are approximate. In pursuance of the Companies policy of constant development, the right is reserved to depart, without notice, from any detail illustrated or specified in this book, without incurring the obligation to provide such modifications on machines previously delivered.*

*No responsibility will be accepted by McConnell Limited for any injury, damage or loss arising from the improper use or lack of maintenance of any machinery supplied by them or from any failure of the user to comply with all instructions published by Tractor or Loader manufacturers, particularly with regard to maximum load capacities, tyre pressures and stability, or with instructions and regulations pertaining to Tractor Cabs.*



This manual describes the Twose'UgtlguABH04 Bale Hand ler. It must b e read and fully understood b efore installing qt 'using the equipment. Reference should als o be made to the operator's manual for the tr actor and loader. Important safety information about handling bales in general will be found in Health & Safety Executive Publication INDG 125 (Handling and Stacking Bales in Agriculture).

Section		Page No
1	Certificate of Conformity	2
2	General Information	3
3	Safety	4
4	Installation	8
5	Maintenance & Storage	9
	Replacement Parts Section	

#### IMPORTANT

This machine is designed for bale handling  
and must not be used for any other purpose

It is potentially hazardous to fit or use  
any parts other than genuine parts

The company disclaims all liability for the  
consequences of such use, which in addition  
voids the machine warranty

We reserve right to modify the technical data and characteristics of the machines at any time without prior notice.

All dimensions and capacities mentioned in this book are approximate. In pursuance of the Companies policy of constant development, the right is reserved to depart, without notice, from any detail illustrated or specified in this book, without incurring the obligation to provide such modifications on machines previously delivered.

No responsibility will be accepted by McConnel Limited for any injury, damage or loss arising from the improper use or lack of maintenance of any machinery supplied by them or from any failure of the user to comply with all instructions published by Tractor or Loader manufacturers, particularly with regard to maximum load capacities, tyre pressures and stability, or with instructions and regulations pertaining to Tractor Cabs.



## General

The ABH04 Bale Handler is designed to handle/stack round wrapped or unwrapped bales. The rolling action of the bale tines eliminates damage to plastic wrapped bales caused by drag between the surfaces. Although designed for mounting on a suitable front loader the handler may also be fitted on the tractor linkage using suitable brackets.

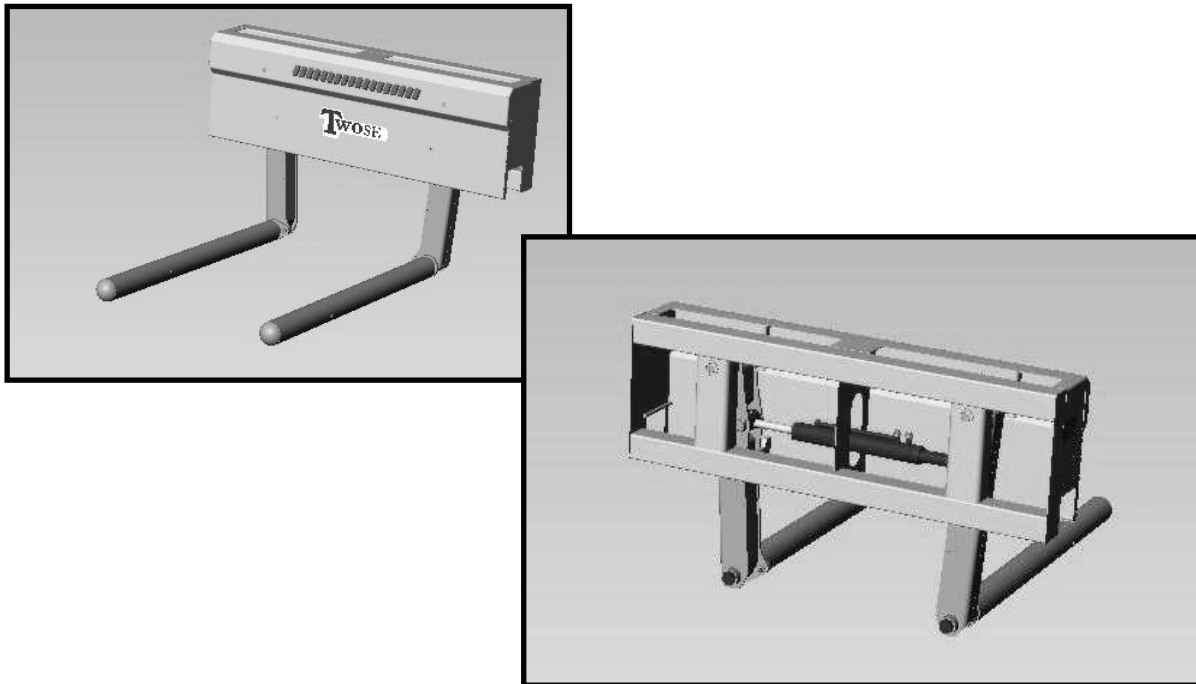

**The ABH 04 Bale Handler**

The bale handler features slide off rollers to reveal the spikes. With the rollers attached the machine is designed to lift one silage/hay bale and with the rollers removed two straw/hay bales or one silage bale. Do not under any circumstances exceed these capacities.

## Technical Details

Machine Weight	170kg
Lift Capacity	1150kg
Roller Length	1.13m
Diameter Bales	4ft – 6ft

## Identifying the machine

Each machine is fitted with an identification plate. Both the data necessary to identify the model and the serial number to order spare parts or after-sales service are stamped on the plate.



### SAFETY NOTES AND WARNINGS

Throughout the handbook the following sub headings are used to draw attention to various points of importance.



This is to draw attention to very important instructions which MUST be followed precisely to avoid injury or death.

### CAUTION

This is used to draw attention to instructions which MUST be followed to avoid damage to operator, machine, process or the environment.

### NOTE:-

This is used to highlight points used for supplementary information.

### HEALTH AND SAFETY



Never attempt to assemble, couple up, or operate machinery until you understand fully the functions, controls and safety precautions required, as shown in the operators manual.



Always follow tractor safety operations and instructions VERY carefully.

**NEVER TAKE RISKS**



**NEVER LEAVE TRACTOR SEAT WHILST ENGINE - OR MACHINE IS RUNNING**



DANGER  
WARNING

Never drive machinery at speeds that could cause danger to other persons or properties, or in a manner that may cause accidents.



DANGER  
WARNING

#### UNSUPPORTED MACHINES

Always ensure the machine is fully supported before getting underneath or working on the machine. Use suitable blocks or packing.



DANGER  
WARNING

Always 'SWITCH OFF' tractor engine before attempting to carry out adjustment or service repairs and inspections, on machinery.



DANGER  
WARNING

Always ensure that the wheels of any wheeled implement/machinery are 'chocked' firmly and implement will not move, before attempting to 'service' or 'work on' in any way or form.



DANGER  
WARNING

Always be aware of your surroundings - and operate machinery accordingly. Beware of confined - tight areas, low height restrictions, buildings and overhangs etc. Also drive and operate bearing in mind weather conditions such as sun, rain, ice, snow, wind etc. [Make allowances in all situations].



DANGER  
WARNING

#### SAFETY CAB

Ensure the tractor is fitted with a glazed safety cab and suitable protection from falling objects,

HIGHWAY USE

When transporting machinery on the Highways the “Local Highways Department” should be consulted for approval and notification, as rules and regulations vary from local authority area to area.

Allow time for walkers and cyclists to clear site. Also when using on the Highway consult the ‘Lighting Regulations’ for correct procedures.

CAUTION

Never carry “passengers” on machinery or on tractor  
Ensure bystanders/onlookers are kept well away from operational area of apparatus.

ON ROAD - TRANSPORT SPEED

When transporting the machinery on the highway:- for example moving from “worksite to worksite” or travelling from home to work or work to home, it is VERY IMPORTANT that transport speed be kept to a low sensible figure – 19 – 25kph (12-15MPH).

The “all-up” (inclusive) weight of a tractor and loader/bale handler is always going to be high, but - the loadings on ALL mountings and implements involved (especially the tractor) are greatly amplified if the unit is driven to travel fast over bumps, potholes, any uneven surfaces or around sharp corners and can result in serious fractures/failures of any or indeed all of the operating machinery involved.



If practical remove spikes/rollers when travelling on the highway. Otherwise cover them so that they are not a danger to others. If possible fold back the spikes/rollers in a safe position when not in use.

POWER LINES

Don’t operate machine under or within 9m horizontal distance of overhead power lines and lower loading equipment when passing under them.

MACHINE CAPACITY

Do not attempt to lift or carry or lift more bales than the equipment is designed to handle.



DANGER  
WARNING

Do not carry bales in a position that will obstruct your vision



DANGER  
WARNING

Lower loader while transporting bales.



DANGER  
WARNING

Ensure that the tractor and loader are suitably counterbalanced

### CAUTION

#### 'PARKING UP' MACHINE

When machine is being removed and being 'parked up' it is essential that a good firm base and level site be found. Always chock and prop machine to ensure a good firm position to leave parked. If fitted ensure that stand legs of machine are correctly locked into position.

### GENERAL INSTRUCTIONS

1. Before attaching any machine to a tractor or loader make sure that implement is still standing firmly on good solid - level site as it will be, providing unit was previously parked correctly.  
- Check that any wheels are 'chocked' correctly and that supports/props are in position where necessary to prevent booms etc. dropping.
2. Before and during the manoeuvring of the tractor or vehicle in order to attach machinery/implements, - make sure that No other persons are in the vicinity.  
Keep other persons well clear and make known your intentions, all the while keeping a sharp lookout whilst reversing and aligning machines for coupling up.
3. Always secure tractor into selected position by ensuring that brakes are applied correctly in order to prevent vehicle moving off on its own to cause injury and damage.
4. Make sure that the lift arms and top link ball ends of the tractor are properly fitted to the machine/implement by using correct adapter sleeves where necessary, and that retaining pins of the correct type are used on all three point linkage points. Secure pins with relevant pin and ring assembly.
5. If the machine is of the drawbar type - check that the hitch on the tractor is in good condition and that the hitch pin used is of the correct size and type, and is properly secured when fitted.
6. Should it become necessary to make any adjustments or service on machine while raised on the tractor linkage, or raised on a front end loader - trestles or suitable supports MUST be positioned to support machine to prevent accidental dropping of lift arms, loader arms or mechanical failure [MACHINE MUST ALWAYS BE PROPPED AND CHOCKED].
7. Never attempt to work on, adjust or service repair machinery of any kind whilst it is still running or working. Always stop the machine and STOP THE TRACTOR ENGINE - before any service/repairs begin.  
(SWITCH OFF TRACTOR ENGINE BEFORE LEAVING TRACTOR SEAT)
8. In transit always use transport stays or locking devices where provided.  
  
If, as in the case of some longer machines, the unit is transported lengthways - make sure that the front of the tractor is suitably ballasted to maintain stability.
9. Always use machines in a sensible and reasonable manner and do not attempt to use them in work for which they are not intended. Avoid overloading and abusing them as this can cause damage to machine and tractor and can be very dangerous.
10. When unhitching/detaching a machine from a tractor three point linkage or from a front end loader ensure that any stands or legs are securely positioned and that the machine is parked where it will not be a safety hazard or cause annoyance to others.  
  
Make sure that chosen 'parking site' is a firm and level site.

## General

Before starting ensure that the machine is on a flat, level hard standing with plenty of room to manoeuvre.

1. Measure the centre distance of both loader arms and crowd links.
2. Position the lift brackets (not provided) on the bale handler frame to suit the dimension above and ensure they are equal distance from each end of the frame.
3. Secure brackets to bale handler frame and tighten nuts fully.
4. Position loader squarely to bale handler frame until holes in lower brackets correspond with holes in loader arms.
5. Fit suitable pins and spacers and secure with linch pins and rings.
6. Fit crowd links into brackets and align holes.
7. Fit suitable pins and spacers and secure with linch pins and rings.
8. The bale handler is now securely attached to the loader.
9. Connect 2 hydraulic hoses (not supplied) from the ports on the ram on the bale handler to a suitable double acting hydraulic service on the tractor.
10. Route the hoses and secure to prevent damage,
11. Test that the loader lifts correctly and the hydraulic ram on the bale handler functions correctly. If necessary reverse the hoses on the ram.
12. If necessary fit ballast weights to the rear of the tractor.

**MAINTENANCE**

Regular maintenance will prolong the life of the machine and ensure it remains in a safe condition.

**DAILY**

- Grease all pivot points.
- Check all nuts and bolts for tightness

**WEEKLY**

- Check hydraulic ram for leaks and hoses for damage and wear and replace if necessary.

**EVERY 2 MONTHS**

- Check plastic bushes for wear.

**STORAGE**

Before storing the machine it should be thoroughly cleaned and a check made for broken or damaged parts so that replacements can be ordered.

Grease the machine. Coat all bright metal parts with grease or oil to prevent corrosion. If necessary use plastic plugs to protect the ram ports. Choose a level hard standing to store the machine preferably under cover. Ensure the machine is safely supported.







McConnel Limited, Temeside Works, Ludlow, Shropshire SY8 1JL. England.  
Telephone: 01584 873131. Facsimile: 01584 876463. [www.mcconnel.com](http://www.mcconnel.com)