

PMSF.42.78.0003

Manuale uso e manutenzione - Catalogo ricambi
Use and maintenance manual - Spare parts catalogue



Use and maintenance manual

Index

1.0 *General information*

- 1.1 Manual consultation
- 1.2 Symbology

2.0 *Technical features*

- 2.1 Identification data
- 2.2 Power train
- 2.3 Disengagement
- 2.4 Brake control adjustment

3.0 *Refuelling and lubrication*

- 3.1 Lubrication of the steering drive axle
- 3.2 Capacity
- 3.3 Type of lubricants

4.0 *Main usage and maintenance*

- 4.1 Preliminary controls
- 4.2 Periodic controls of the oil levels
- 4.3 Oil replacement
- 4.4 Further oil replacements

5.0 *Maintenance*

- 5.1 Planned maintenance schedule

6.0 *Maintenance products*

- 6.1 Table of maintenance products

7.0 *Torque wrench setting*

- 7.1 Torque wrench setting table



1.0 General information

1.1 Manual consultation

This manual has been issued in order to supply the operator with the main information related to all interventions of maintenance and replacement of the original parts for the above mentioned product. All the interventions here described require experience and competence of the operators, who are asked to comply fully with original technical features indicated by the manufacturer.

Some information was intentionally not reported, since they must be a primary part of the basic necessary technical culture each skilled technician should have. Further information related to components assembling can be found in the spare parts catalogue.

Important

This manual also contains the necessary controls which must be issued during the starting up of the product.

Dromos s.r.l. refuses all responsibility for possible technical mistakes and omissions, made during the preparation of this manual and reserves the right to effect any modification required by the technological development of its products, without any obligation of immediate spreading.

All information herewith reported are updated to the edition date.

Important

It is absolutely forbidden to reproduce or spread even partially the information given in this manual. Any right is reserved to Dromos s.r.l., to whom you will have to ask for the authorization (in written form) by specifying the reasons of the request.



1.2 Symbology

For a quick and efficient reading of this usage and maintenance manual, symbols pointing out situations of maximum attention, practical suggestions or simple information were adopted. We recommend to pay great attention to the symbols meaning, since their main purpose is avoiding the repetition of technical concepts or safety warning. Hence, they must be really considered as “memo.”



Be careful

Not complying with these reported instructions might cause a dangerous situation.



Important

It shows the possibility to create damage to the product and/or the components if reported instructions are not strictly followed.



Notes

It provides useful information for the operation in progress.



2.0 **Technical features**

2.1 **Identification data**

On the steering drive axle body is affixed an indicating plate with product serial number.

2.2 **Power train**

- *Axle body* Spiral bevel gear and pinion, straight-tooth bevel gears. The axle is made up by seven parts: central body (Tab. 1 -18), differential supports (Tab. 1 - 33) (Tab. 1 - 62), housings (Tab. 2 - 14) and side steering bodies (Tab. 3 - 5). The above mentioned parts are connected one to the other by means of screws (Tab. 2 - 16) (Tab. 2 - 17) (Tab. 3 - 4). On the housings are located the multi-disc wet brakes with the related control.

- *Planetary gearbox* Spur gears. The gearbox is made up by one annular gear (Tab. 4 - 17) and one planetary carrier (Tab. 4 - 18). The annular gear (Tab. 4 - 17) is integral to the annular gear hub (Tab. 4 - 9), that is splined onto the spindle (Tab. 3 - 20). The spindle (Tab. 3 - 20) is connected to the external half articulated joint (Tab. 3 - 1) (Tab. 3 - 8) by means of screws (Tab. 3 - 22) (Tab. 3 - 23). The external half articulated joint (Tab. 3 - 1) (Tab. 3 - 8) is connected to the steering drive axle by means of the articulation pins (Tab. 3 - 7) (Tab. 3 - 11).

The driving torque, when entering into the transmission flange (Tab. 1 - 3) splined to the conical pinion (Tab. 1 - A), is transmitted to the bevel gear (Tab. 1 - B). This one, being fixed with screws (Tab. 1 -30) (Tab. 1 - 31), will transmit the torque to the differential gearing (Tab. 1 - 29). In this way, the driving torque will be transmitted to the cardan shafts (Tab. 3 - 19), which will transmit the driving torque to the planetary gearboxes (Tab. 4 - 18) integral to the wheel hubs (Tab. 4 - 5).



2.3 Disengagement

- *Differential locking* The control of this disengagement is pneumatic and mechanic type and equipped with the switch (Tab. 1 - 51) that detects the engagement and disengagement positions of the clutch sleeve. The system, from which compressed air is taken out, should supply dehumidified air must be kept to the same pressure and **max 10 bar**. When the pneumatic control with single effect is engaged, it is necessary to comply with the following instructions:

a) *Locking phase* Give pressure to the clutch sleeve pneumatic control (Tab. 1 - 55). If the pilot light, which is connected to the related position switch (Tab. 1 - 51) and signals the occurred engagement, would not switch on, it will be necessary to turn very slowly the transmission flange (Tab. 1 - 3), in order to make the engagement easy.

b) *Unlocking phase* Take pressure off the clutch sleeve pneumatic control (Tab. 1 - 55). In this way, spring (Tab. 1 - 39) will bring the clutch sleeve into disengagement position (Tab. 1 - 55). If the other pilot light, which is connected to the related position switch (Tab. 1 - 51) and signals the occurred engagement, would not switch off, it will be necessary to turn very slowly the transmission flange (Tab. 1 - 3) with a clockwise or anti-clockwise movement, in order to remove the possible pressures occurring on the engaging toothings, by making in this way the operation easy.



2.4 Brake control adjustment

The brake control cylinder (brake actuating piston) (Tab. 2 - 11), is made up by one body having the sole function of positive service brake. For a correct operation of the brake cylinder, the commercial product to be used must comply with the following specifications: **DIN 51524**.

The sprag, operated by the body and moving in axial direction, acts on the disks body (Tab. 2 - 8) and consequently on the fixed disks (Tab. 2 - 5) and on the clutch disks (Tab. 2 - 6) for service brake.

In case the service braking function would not take place anymore, replacement of the clutch disks (Tab. 2 - 6) will be requested, without needing any adjustment of the sprag stroke.



In case of re-assembly of the brake discs kit (Tab. 2 - 7) and brake body (Tab. 2 - 8), due to a substitution or during extraordinary maintenance which implies its disassembly, we recommend to put all the friction discs (Tab. 2 - 6) in phase, so that the holes for oil passage can coincide and to put all the intermediate discs (Tab. 2 - 5) in phase, **as per enclosed scheme**, in order to grant a correct brake operation.

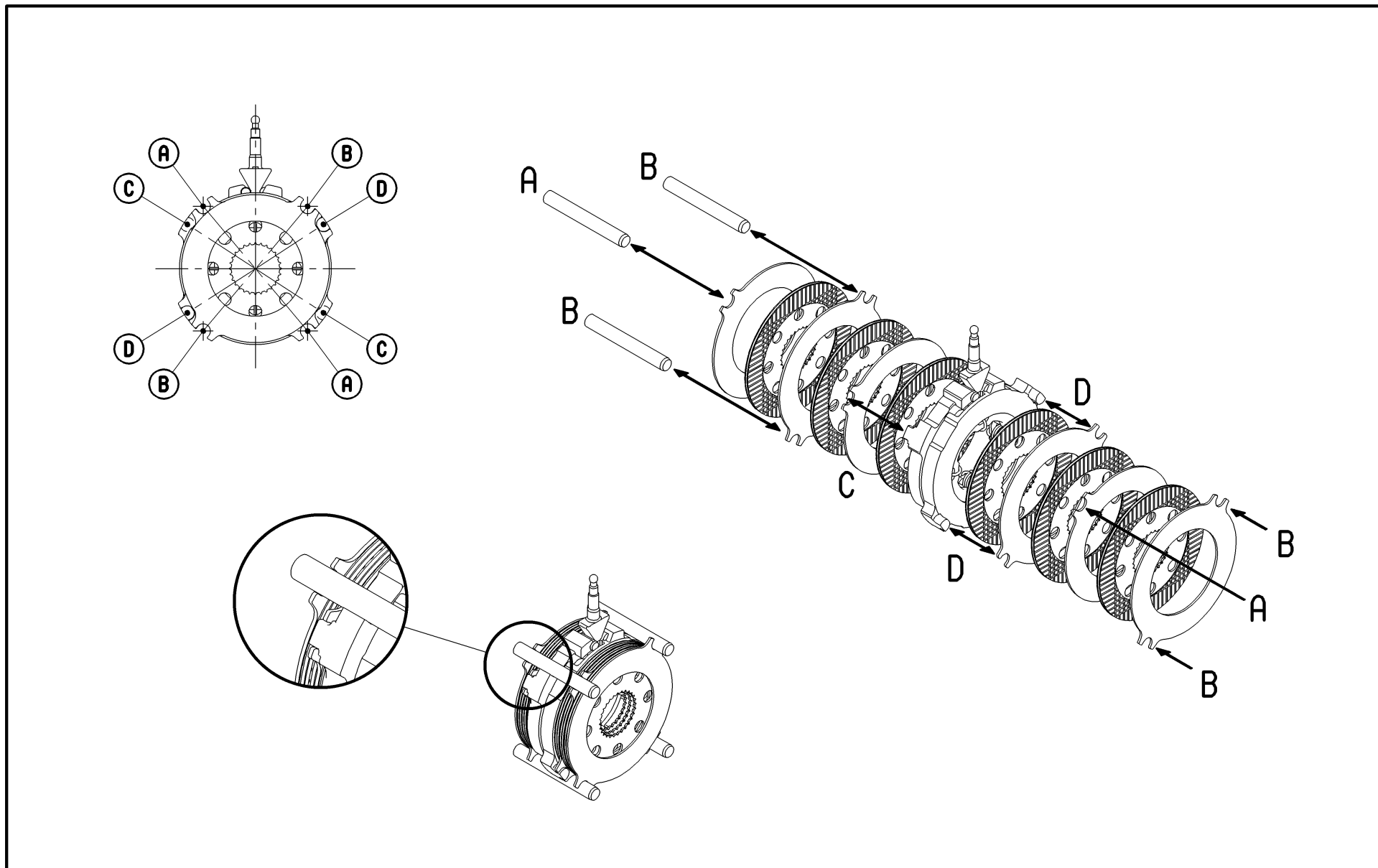

3.0 Refuelling and lubrication

3.1 Lubrication of the steering drive axle

The splash lubrication system is conceived for lubricating all the gear wheels and the bearings enough and under every working condition.

3.2 Capacity

- *Axle body* 16,50 litres
- *Planetary gearboxes* 1,90 litres (each one)

3.3 Type of lubricant

The commercial product to be used must comply with the following specification:

- *Axle body - planetary gearboxes*

Lubricant type	completely synthetic PAO
SAE grade	75W-90
API	GL-5



4.0 Main usage and maintenance

4.1 Preliminary controls

The transmission leaves manufacturer's plant without lubricant oil. Before running it is therefore important the refuelling with lubricating oil.

- Axle body

Remove the filling gauge (Tab. 1 - 19), the washer (Tab. 1 - 20) and level gauge (Tab. 2 - 18) located on the sump (Tab. 2 - 14). Then add the prescribed oil until the required level is reached, by checking through the same gauge.

Level should be kept on the lower edge of the level indicating hole.

Reassemble the filling gauge (Tab. 1 - 19), the washer (Tab. 1 - 20) and the level gauge again (Tab. 2 - 18), then clamp to the prescribed torque.

- Planetary gearbox

Remove the filling and level gauges (Tab. 4 - 26) and the washers (Tab. 4 - 25) located on the planetary carriers (Tab. 4 - 18). Then add the prescribed oil until the required level is reached, by checking through the same plug.

Level should be kept on the lower edge of the level indicating hole.

Reassemble the filling and level gauges (Tab. 4 - 26) and the washers Tab. 4 - 25) again and then clamp to the prescribed torque.



Important

After a short running and when it is sure that oil was spread through the transmission and collection sumps are full, check oil level and in case make toppings up.

4.2 Regular checking of oil levels

Check the oil level weekly.

- Axle body

Oil level can be checked by removing the filling and level gauge (Tab. 2 - 18) located on the housing (Tab. 2 - 14).

Wait for some minutes after the axle stopping, in order to settle the oil level.

Check the level with the axle in horizontal position and with warm oil.

Level should be kept on the lower edge of the level indicating hole. If level results to be inadequate, make toppings up. Add the prescribed oil until required level is reached.

Reassemble the filling and level gauge (Tab. 2 -18) and then clamp to the prescribed torque.

- Planetary gearbox

Oil level can be checked by removing the filling and level gauges (Tab. 4 - 26) and the washers (Tab. 4 - 25) located on the planetary carriers (Tab. 4 - 18).

Wait for some minutes after the axle stopping, in order to settle the oil level.

Check the level with the axle in horizontal position and with warm oil.

Level should be kept on the lower edge of the level indicating hole. If level results to be inadequate, make toppings up. Add the prescribed oil until required level is reached.

Reassemble the filling and level gauges (Tab. 4 - 26) and the washers (Tab. 4 - 25) and then clamp to the prescribed torque.



Notes

Once each control is made, check the efficiency of the breather plug (Tab. 2 - 15) located on the housing (Tab. 2 - 14), wash it with solvent and dry with air blowing.

4.3 Oil replacement



Notes

This operation should be made with hot oil. As a matter of facts, in these conditions oil is more fluid and its draining is quicker and complete.

- *Axle body*

Remove the magnetic drain plug (Tab. 1 - 21) and the washer (Tab. 1 - 20) from the central body (Tab. 1 - 18). Then drain used up oil.

- *Planetary gearbox*

Remove the drain plugs (Tab. 4 - 26) and the washers (Tab. 4 - 25) from the planetary carriers (Tab. 4 - 18). Then drain used up oil.



Be careful

Do not waist used up oil in the environment.

Transmission oil should be replaced for the first time after a **50 hours** working period, calculated using the vehicle on following conditions:

- working speed
- transfer speed

Check that no metallic particles are laying on the magnetic end of the drain plug (Tab. 1 - 21), then screw again the magnetic drain plug (Tab. 1 - 21) and the washer (Tab. 1 - 20) in the central body (Tab. 1 - 18) and the drain plugs (Tab. 4 - 26) with washers (Tab. 4 - 25) in the planetary carriers (Tab. 4 - 18). Then, clamp to the prescribed torque.

4.4 Further oil replacements

Each **500 hours**, calculated using the vehicle on following conditions:

- working speed
- transfer speed or anyway **once a year**.

5.0 Maintenance

5.1 Planned maintenance schedule

Replace lubricating oil by following the indicated instructions and verify during each oil replacement the presence of possible oil leakages.

Renew the greasing of articulation pins by means of grease guns every **100 hours** working period or during an extraordinary maintenance that would require a disassembly of them.

6.0 Products for maintenance

6.1 Table of maintenance products

- Lithium based grease for plain and rolling bearings submitted to long lasting mechanical stresses	Castrol Spheerol EPL 2
- Thread locker with weak mechanical strength	Loctite 222
- Thread locker with middle mechanical strength oil compatible	Loctite 243
- Permanent locker for threaded parts, bearings, bushes, splined parts and keys, oil compatible	Loctite 603
- Liquid sealant for surfaces	Loctite 5399
- Solvent	Loctite 7063



Notes

Liquid sealant for surfaces should be correctly applied in all the parts where oil is passing through. All exceeding parts should be removed.

7.0 Torque wrench setting

7.1 Torque wrench setting table

Tab. 1

APPLICATION	SCREW THREAD	CLASS (ISO 898)	Nm Tolerance \pm 10%	NOTES
Screw (34)	M8x1,25	12.9	42	Loctite 243
Screw (53)	M12x1,75	10.9	122	Loctite 243
Screw (61)	M12x1,75	12.9	147	Loctite 243
Screw (9)	M14x2	12.9	234	Loctite 243
Screw (30) (31)	M16x1,5	10.9	320	Loctite 243
Ring nut (1)	M45x1,5	10.9	400	Loctite 603
Plug (19) (21)	M22x1,5	-	80	-

Tab. 2

APPLICATION	SCREW THREAD	CLASS (ISO 898)	Nm Tolerance \pm 10%	NOTES
Screw (13)	M10x1,5	12.9	85	Loctite 243
Screw (16) (17)	M18x2,5	12.9	492	Loctite 243
Plug (1) (15)	M10x1	5.8	25	-
Plug (18)	M22x1,5	5.8	85	-



Tab. 3

APPLICATION	SCREW THREAD	CLASS (ISO 898)	Nm Tolerance ± 10%	NOTES
Screw (12)	M16x2	8.8	212	Loctite 243
Screw (22) (23)	M18x2,5	12.9	492	Loctite 243
Screw (4)	M20x2,5	12.9	697	Loctite 243

Tab. 4

APPLICATION	SCREW THREAD	CLASS (ISO 898)	Nm Tolerance ± 10%	NOTES
Screw (19)	M6x1	45 H	17	Loctite 243
Screw (24)	M8x1,25	10.9	35	Loctite 243
Screw (11)	M12x1,75	8.8	87	Loctite 243
Screw (15)	M12x1,75	12.9	147	Loctite 243
Screw nut (27)	M22x1,5	10	500	-
Ring nut (10)	M95x2	4.6	-	-
Plug (26)	M16x1,5	5.8	50	-

Tab. 5

APPLICATION	SCREW THREAD	CLASS (ISO 898)	Nm Tolerance ± 10%	NOTES
Screw (16)	M14x2	8.8	138	Loctite 243
Screw (1)	M16x2	8.8	212	Loctite 243
Screw (14)	M18x2,5	12.9	492	Loctite 243
Nut (15)	M14x2	8	138	-
Nut (6)	M27x1,5	8	280	-
Nut (9)	M28x1,5	8	400	-





Product:
Edition:

PMSF.42.78.0003
25-02-2015

ESEMPIO DI ORDINAZIONE ORDER EXAMPLE SPECIMEN DE COMMANDE

NELLE ORDINAZIONI CITARE SEMPRE

- 1) Numero di matricola
- 2) Data di edizione
- 3) Codice del particolare
- 4) Quantità

IN YOUR ORDERS INDICATE ALWAYS

- 1) Serial number
- 2) Edition date
- 3) Code number of the part
- 4) Quantity

COMMENT COMMANDER LES PIECES DE RECHANGE

- 1) Numero d'immatriculation
- 2) Date d'edition
- 3) Code de la piece
- 4) Quantité

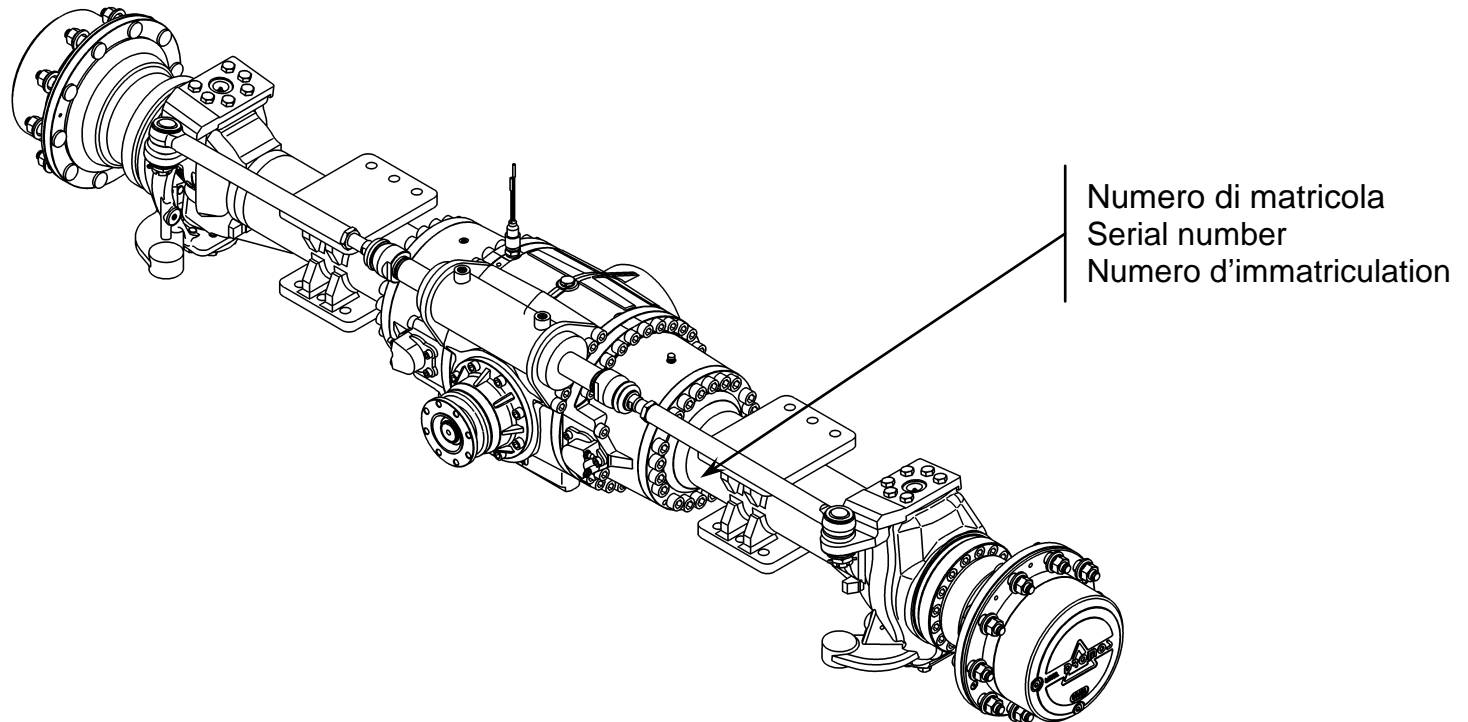

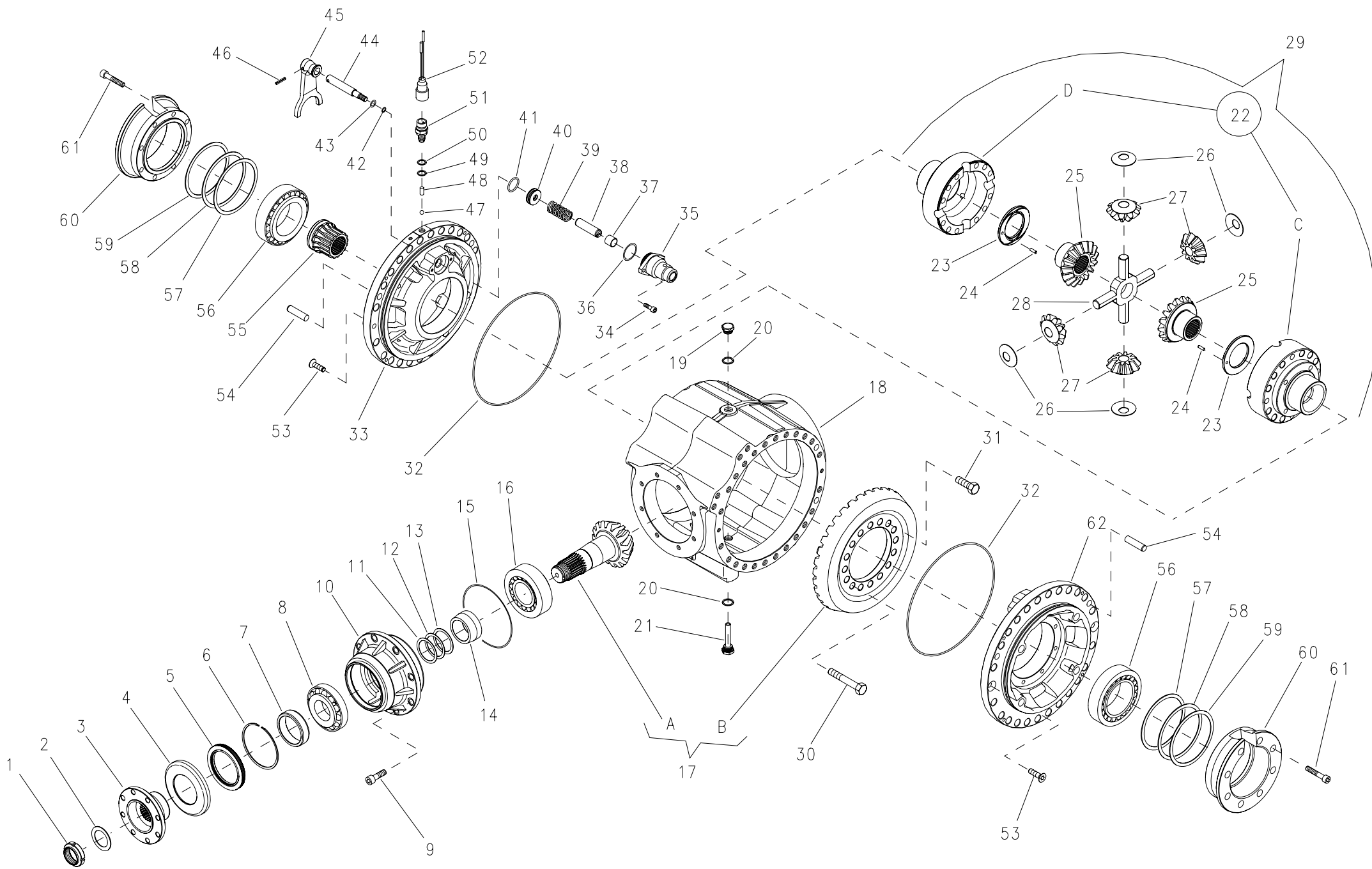

PMSF.42.78.0003

25-02-2015



PMSF.42.78.0003

Tab.	Item	Code	Descrizione	Description	Déscription	Qty
1						
	1	012.450.0080.1	GHIERA	RING NUT	ECROU	1
	2	001.031.0020.0	RONDELLA PER GHIERA	WASHER FOR RING NUT	RONDELLE POUR ECROU	1
	3	012.230.1240.1	FLANGIA TRASMISSIONE	TRANSMISSION FLANGE	BRIDE DE TRASMISSION	1
	4	012.370.0060.1	PROTEZIONE PER ANELLO TENUTA OLIO	OIL SEAL PROTECTION	PROTECTION POUR BAGUE D'ETANCHEITE	1
	5	001.060.0780.0	ANELLO TENUTA OLIO	OIL SEAL	BAGUE D'ETANCHEITE D'HUILE	1
	6	001.081.0280.0	ANELLO DI SPALLAMENTO	SHOULDER RING	ANNEAU D'EPAULEMENT	1
	7	012.321.0580.1	PISTA PER ANELLO TENUTA OLIO	OIL SEAL RING RACE	PORTEE DE COULIS. BAGUE D'ETANCHEITE	1
	8	001.013.0290.0	CUSCINETTO	BEARING	ROULEMENT	1
	9	001.091.0020.0	VITE	SCREW	VIS	8
	10	012.140.0460.1	BUSSOLA PORTA CUSCINETTI	BEARING SUPPORT BUSH	DOUILLE PORTE-PALIER	1
	11	012.310.0140.1	SPESSORE REGISTRO	SHIM	CALE DE REGLAGE	2
	12	012.310.0150.1	SPESSORE REGISTRO	SHIM	CALE DE REGLAGE	4
	13	012.310.0160.1	SPESSORE REGISTRO	SHIM	CALE DE REGLAGE	2
	14	012.320.1220.1	DISTANZIALE	SPACER	ENTRETOISE	1
	15	001.061.0310.0	ANELLO OR	O-RING	JOINT TORIQUE	1
	16	001.013.0420.0	CUSCINETTO	BEARING	ROULEMENT	1
	17	808.010.1000.0	COPPIA CONICA	BEVEL GEAR AND PINION	COUPLE CONIQUE	1
	18	012.120.2340.1	CORPO CENTRALE	CENTRAL CASING	GROUPE CORPS CENTRAL	1
	19	001.151.0050.0	TAPPO	PLUG	BOUCHON	1
	20	001.159.0040.0	GUARNIZIONE	GASKET	JOINT	2
	21	002.156.0010.1	TAPPO MAGNETICO	MAGNETIC PLUG	BOUCHON MAGNETIQUE	1
	22	808.020.0150.0	GRUPPO DIFFERENZIALE	DIFFERENTIAL UNIT	GROUPE DIFFERENTIEL	1
	23	012.300.0410.1	RASAMENTO PLANETARIO CONICO DIFF.LE	CROWN WHEEL SUPPORT RING	RONDELLE D'APPUI PLANETAIRE DIFF.	2
	24	001.132.0150.0	SPINA CILINDRICA	PARALLEL PIN	GOUPILLE CYLINDRIQUE	2
	25	012.262.0160.1	RUOTA PLANETARIA CONICA	BEVEL PLANETARY GEAR	ROUE PLANETAIRE CONIQUE	2
	26	012.300.0400.1	RASAMENTO SATELLITE CONICO DIFF.LE	DIFFERENTIAL PLANETARY SUPPORT RING	RONDELLE D'APPUI SATELLITE DIFF.	4
	27	012.262.0170.1	RUOTA SATELLITE CONICA	BEVEL PLANETARY GEAR	ROUE SATELLITE CONIQUE	4
	28	012.271.0040.1	CROCIERA	CROSS	CROISILLON	1
	29	909.050.0160.0	GRUPPO DIFFERENZIALE	DIFFERENTIAL UNIT	GROUPE DIFFERENTIEL	1
	30	001.090.0510.0	VITE	SCREW	VIS	12



PMSF.42.78.0003

Tab.	Item	Code	Descrizione	Description	Déscription	Qty
1						
	31	001.090.0520.0	VITE	SCREW	VIS	4
	32	001.061.0140.0	ANELLO OR	O-RING	JOINT TORIQUE	2
	33	012.120.2600.1	SUPPORTO DIFFERENZIALE	DIFFERENTIAL SUPPORT	SUPPORT DIFFERENTIEL	1
	34	001.091.0140.0	VITE	SCREW	VIS	2
	35	012.010.7950.1	CORPO CILINDRO BLOCCAGGIO	LOCKING CYLINDER CASING	CORPS CYLINDRE DE BLOCAGE	1
	36	001.061.0020.0	ANELLO OR	O-RING	JOINT TORIQUE	1
	37	001.040.0130.0	BOCCOLA	BUSHING	BAGUE	1
	38	012.010.7610.1	PROLUNGA PER ASTA FORCELLA	ROD EXTENSION	RALLONGE POUR TIGE	1
	39	012.490.0310.1	MOLLA	SPRING	RESSORT	1
	40	012.010.7940.1	PISTONE	PISTON	PISTON	1
	41	001.061.0330.0	ANELLO OR	O-RING	JOINT TORIQUE	1
	42	001.061.0630.0	ANELLO OR	O-RING	JOINT TORIQUE	1
	43	001.061.0390.0	ANELLO OR	O-RING	JOINT TORIQUE	1
	44	012.272.0680.1	ASTA PER FORCELLA	FORK ROD	TIGE POUR FOURCHETTE	1
	45	012.351.0670.1	FORCELLA	FORK	FOURCHETTE	1
	46	001.133.0080.0	SPINA ELASTICA	SPRING PIN	GOUPILLE ELASTIQUE	1
	47	001.033.0010.0	SFERA	BALL	BILLE	1
	48	002.132.0060.1	SPINA CILINDRICA	PARALLEL PIN	GOUPILLE CYLINDRIQUE	1
	49	012.310.0340.1	SPESSORE REGISTRO	SHIM	CALE DE REGLAGE	5
	50	012.310.0680.1	SPESSORE REGISTRO	SHIM	CALE DE REGLAGE	5
	51	001.440.0250.0	INTERRUTTORE	SWITCH	INTERRUPTEUR	1
	52	001.490.0060.0	BLOCCHETTO DI CONNESSIONE	CABLE CONNECTOR	BLOCHET DE CONNEXION	1
	53	001.092.0080.0	VITE	SCREW	VIS	4
	54	001.132.0370.0	SPINA CILINDRICA	PARALLEL PIN	GOUPILLE CYLINDRIQUE	2
	55	012.231.2400.1	MANICOTTO INNESTO	CLUTCH SLEEVE	MANCHON DE CRABOTAGE	1
	56	001.013.0530.0	CUSCINETTO	BEARING	ROULEMENT	2
	57	012.310.0360.1	SPESSORE REGISTRO	SHIM	CALE DE REGLAGE	5
	58	012.310.0370.1	SPESSORE REGISTRO	SHIM	CALE DE REGLAGE	5
	59	012.310.0380.1	SPESSORE REGISTRO	SHIM	CALE DE REGLAGE	5
	60	012.320.2970.1	DISTANZIALE DI REGISTRO	ADJUSTMENT SPACER	ENTRETOISE DE REGLAGE	2



PMSF.42.78.0003

Tab.	Item	Code	Descrizione	Description	Déscription	Qty
1						
	61	001.091.0690.0	VITE	SCREW	VIS	16
	62	012.120.2310.1	SUPPORTO DIFFERENZIALE	DIFFERENTIAL SUPPORT	SUPPORT DIFFERENTIEL	1

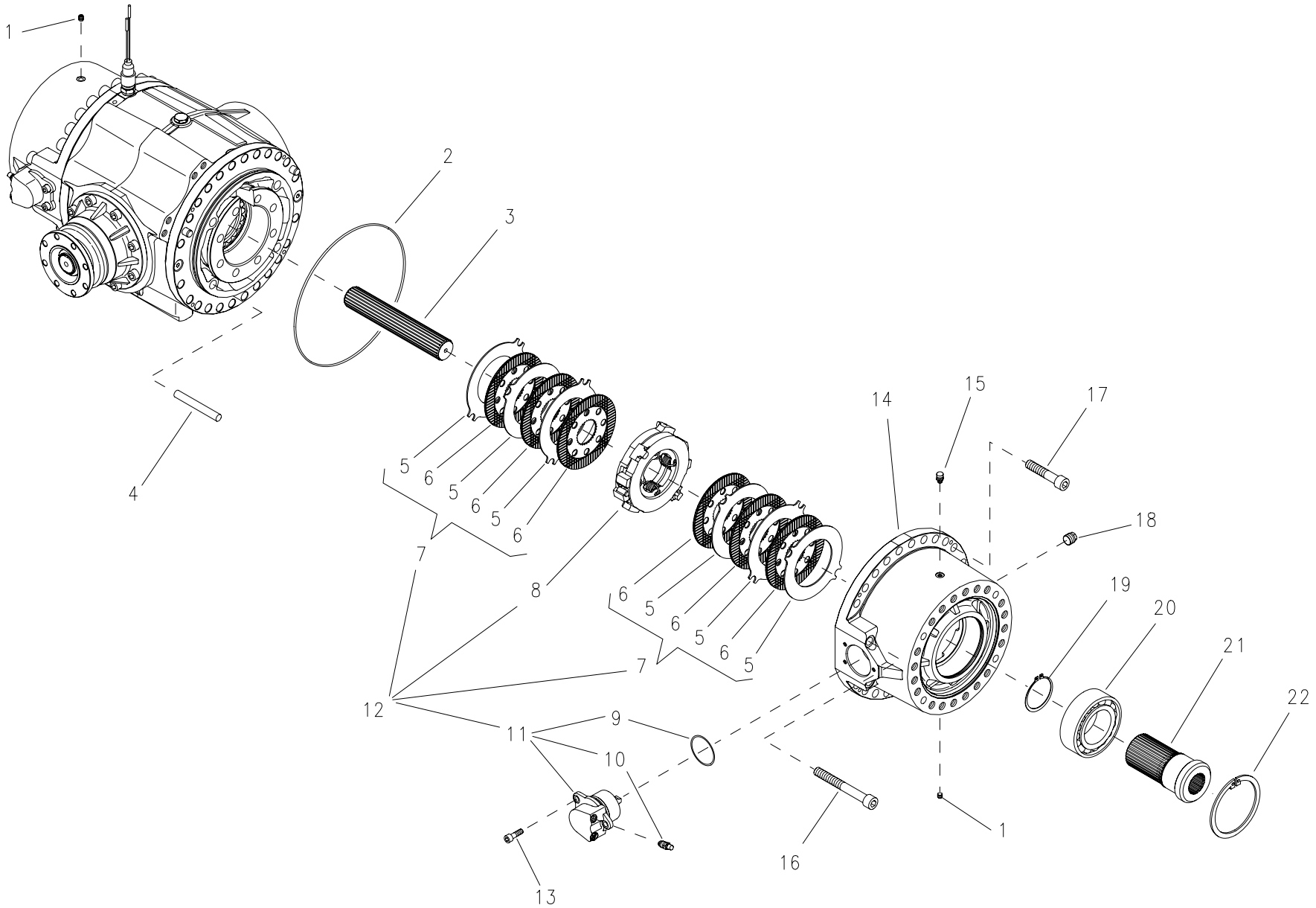



PMSF.42.78.0003

Tab.	Item	Code	Descrizione	Description	Déscription	Qty
2						
	1	001.150.0020.0	TAPPO	PLUG	BOUCHON	3
	2	001.061.0340.0	ANELLO OR	O-RING	JOINT TORIQUE	2
	3	012.180.0710.1	SEMIASSE	DRIVE SHAFT	DEMI-ARBRE	2
	4	001.132.0220.0	SPINA CILINDRICA	PARALLEL PIN	GOUPILLE CYLINDRIQUE	8
	5	012.081.0050.1	CONTRODISCO	INTERMEDIATE DISC	CONTRE-DISQUE	12
	6	012.082.0050.1	DISCO DI FRIZIONE	CLUTCH DISK	DISQUE DE FRICTION	12
	7	707.970.0050.0	KIT DISCHI FRENO	BRAKE DISCS KIT	KIT DISQUES FREIN	2
	8	707.960.0080.0	CORPO FRENO	BRAKE CASING	CORPS FREIN	2
	9	001.061.0940.0	ANELLO OR	O-RING	JOINT TORIQUE	2
	10	003.010.0220.1	VITE DI SPURGO	BLEED SCREW	VIS DE PURGE	2
	11	001.430.0150.0	CILINDRETTO ATTUATORE FRENO	BRAKE ACTUATION CYLINDER	CYLINDRE ACTIONNEUR DU FREIN	2
	12	707.950.0040.0	FRENO A DISCHI	DISC BRAKE	FREIN A DISQUES	2
	13	001.091.0210.0	VITE	SCREW	VIS	6
	14	012.030.1660.1	CARTER	CASING	CARTER	2
	15	001.155.0010.0	TAPPO SFIATO	BREATHER PLUG	RENIFLARD	1
	16	001.091.1370.0	VITE	SCREW	VIS	4
	17	001.091.1360.0	VITE	SCREW	VIS	44
	18	001.150.0010.0	TAPPO	PLUG	BOUCHON	2
	19	001.070.0200.0	ANELLO ELASTICO	RETAINING RING	CIRCLIP	2
	20	001.004.0020.0	CUSCINETTO	BEARING	ROULEMENT	2
	21	012.231.2590.1	MANICOTTO PER FRENO A DISCHI	SLEEVE FOR DISC BRAKE	MANCHON POUR FREIN A DISQUES	2
	22	001.071.0430.0	ANELLO ELASTICO	RETAINING RING	CIRCLIP	2

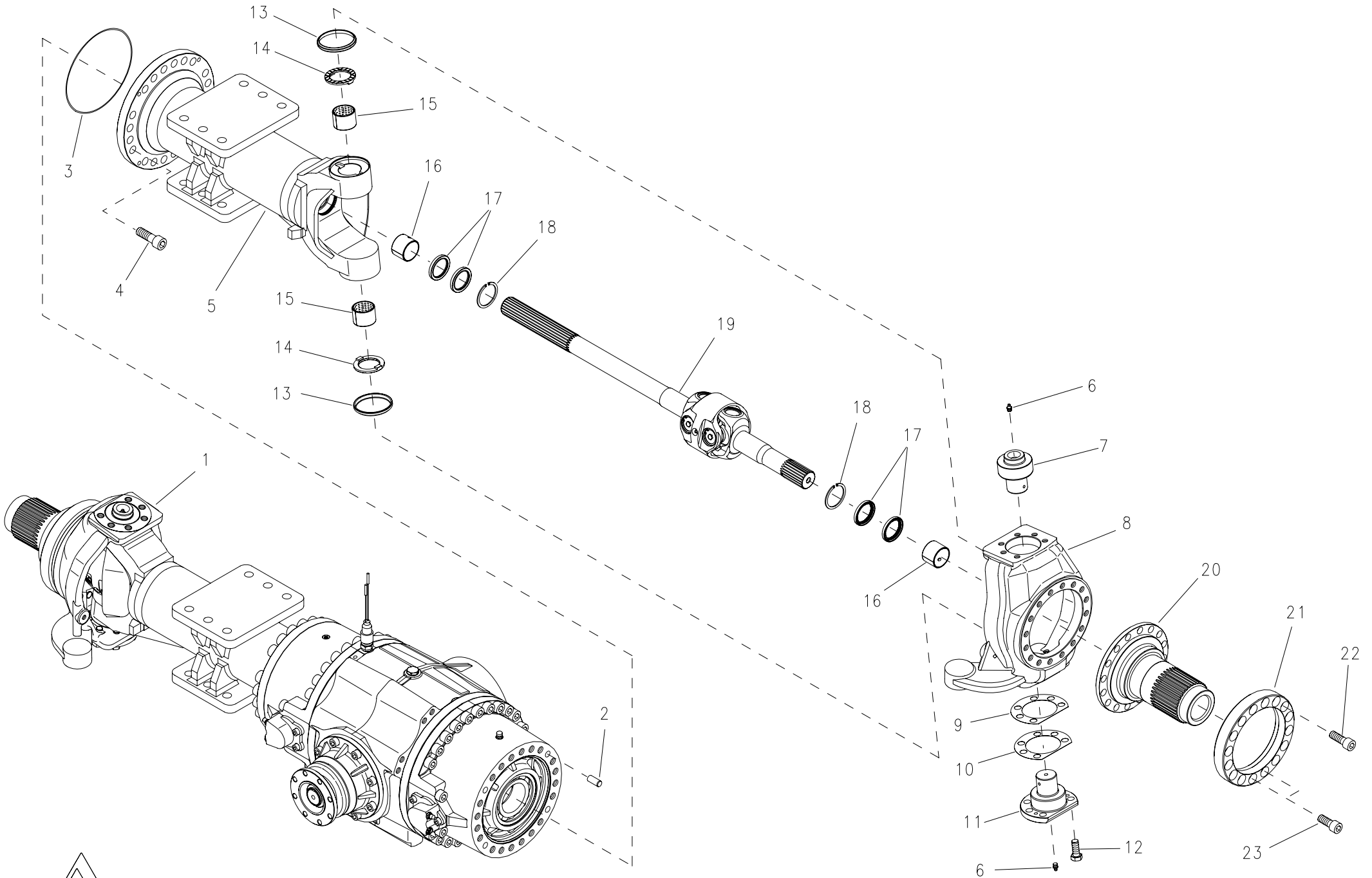

PMSF.42.78.0003

25-02-2015



PMSF.42.78.0003

Tab.	Item	Code	Descrizione	Description	Déscription	Qty
3						
	1	012.160.0920.1	SEMISNODO ESTERNO DX	EXTERNAL RIGHT HALF ARTICULATION	DEMI-ARTICULATION EXT. DROITE	1
	2	001.132.0230.0	SPINA CILINDRICA	PARALLEL PIN	GOUPILLE CYLINDRIQUE	2
	3	001.061.1410.0	ANELLO OR	O-RING	JOINT TORIQUE	2
	4	001.091.0730.0	VITE	SCREW	VIS	40
	5	012.120.2650.1	CORPO LATERALE STERZANTE	STEERING SIDE CASING	TROMPETTE MOTO-DIRECTEUR	2
	6	001.180.0020.0	INGRASSATORE	LUBRICATOR	GRAISSEUR	4
	7	012.270.0820.1	PERNO SNODO	ARTICULATION PIN	AXE D'ARTICULATION	2
	8	012.160.0910.1	SEMISNODO ESTERNO DX	EXTERNAL RIGHT HALF ARTICULATION	DEMI-ARTICULATION EXT. DROITE	1
	9	012.312.0350.1	SPESSORE REGISTRO	SHIM	CALE DE REGLAGE	5
	10	012.312.0360.1	SPESSORE REGISTRO	SHIM	CALE DE REGLAGE	5
	11	012.270.0740.1	PERNO SNODO	ARTICULATION PIN	AXE D'ARTICULATION	2
	12	001.090.0020.0	VITE	SCREW	VIS	12
	13	001.062.0110.0	ANELLO PARAPOLVERE	WIPER RING	BAGUE PARE-POUSSIÈRE	4
	14	012.540.0020.1	RALLA REGGISPISTA	THRUST WASHER	COUETTE DE BUTÉE	4
	15	001.040.0230.0	BOCCOLA	BUSHING	BAGUE	4
	16	001.040.0010.0	BOCCOLA	BUSHING	BAGUE	4
	17	001.060.0030.0	ANELLO TENUTA OLIO	OIL SEAL	BAGUE D'ÉTANCHEITÉ D'HUILE	8
	18	001.071.0010.0	ANELLO ELASTICO	RETAINING RING	CIRCLIP	4
	19	012.190.0510.1	GIUNTO CARDANICO CON SEMIASSI	UNIVERSAL JOINT WITH DRIVE SHAFTS	JOINT DE CARDAN AVEC DEMI-ESSIEUX	2
	20	012.240.0410.1	FUSO	SPINDLE	FUSEE	2
	21	012.010.7690.1	ANELLO PARAPOLVERE	WIPER RING	BAGUE PARE-POUSSIÈRE	2
	22	001.091.0490.0	VITE	SCREW	VIS	28
	23	001.091.0240.0	VITE	SCREW	VIS	4

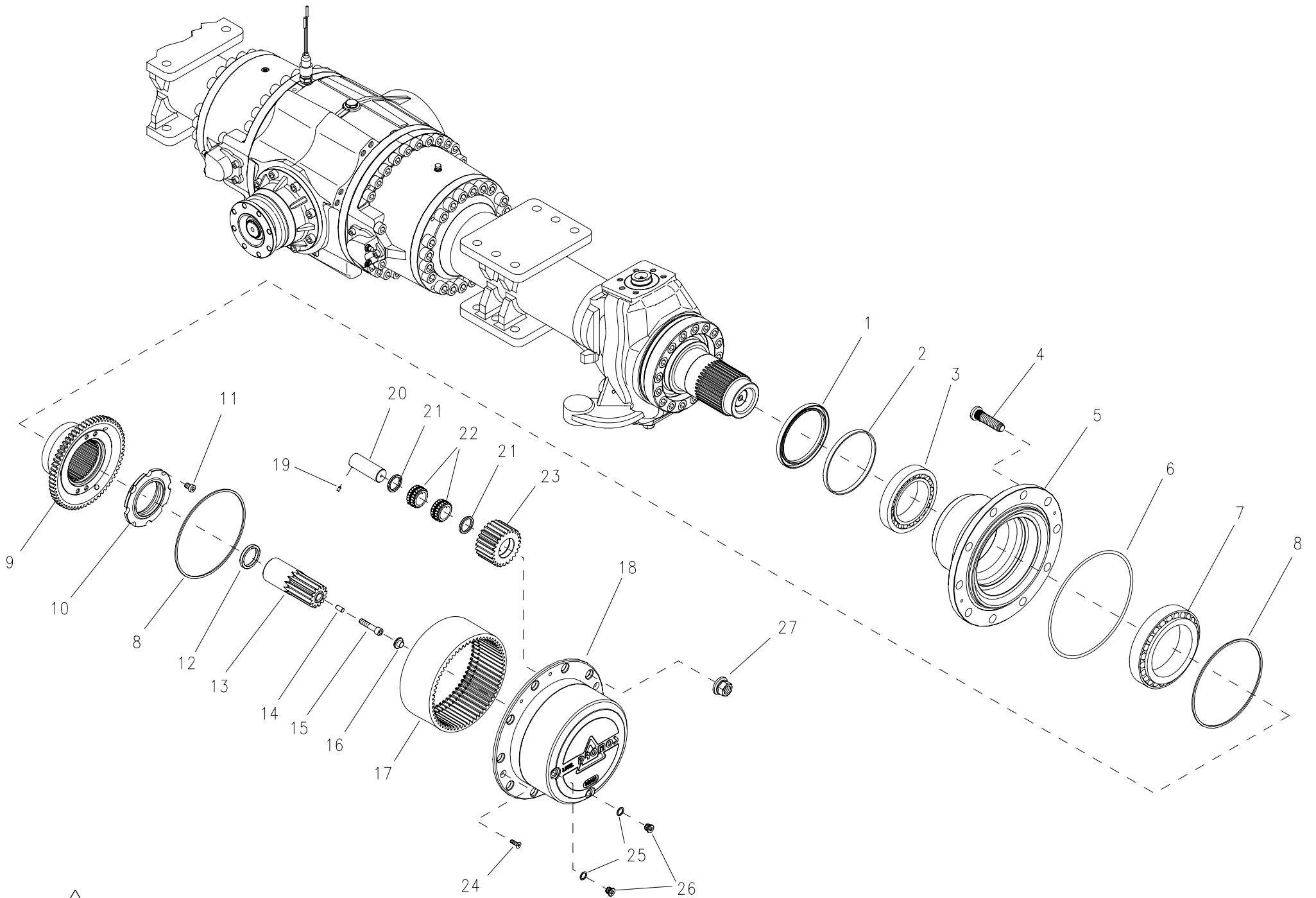

PMSF.42.78.0003

25-02-2015



PMSF.42.78.0003

Tab.	Item	Code	Descrizione	Description	Déscription	Qty
4						
	1	001.060.0090.0	ANELLO TENUTA OLIO	OIL SEAL	BAGUE D'ETANCHEITE D'HUILE	2
	2	012.320.1410.1	DISTANZIALE	SPACER	ENTRETOISE	2
	3	001.013.0040.0	CUSCINETTO	BEARING	ROULEMENT	2
	4	012.360.0120.1	COLONNETTA	STUD	GOUJON	20
	5	012.101.0390.1	MOZZO RUOTA	WHEEL HUB	MOYEU DE ROUE	2
	6	001.061.0050.0	ANELLO OR	O-RING	JOINT TORIQUE	2
	7	001.013.0330.0	CUSCINETTO	BEARING	ROULEMENT	2
	8	001.081.0230.0	ANELLO DI SPALLAMENTO	SHOULDER RING	ANNEAU D'EPAULEMENT	4
	9	012.250.4940.1	MOZZO PER CORONA EPICICLO	HUB FOR PLANETARY ANNULUS GEAR	MOYEU COURONNE ENGRENAGE PLANET.	2
	10	012.450.0270.1	GHIERA	RING NUT	ECROU	2
	11	001.091.1340.0	VITE	SCREW	VIS	4
	12	012.320.2920.1	DISTANZIALE	SPACER	ENTRETOISE	2
	13	012.250.4920.1	RUOTA SOLARE	SUN GEAR	ROUE SOLAIRE	2
	14	002.132.0020.1	SPINA CILINDRICA	PARALLEL PIN	GOUPILLE CYLINDRIQUE	2
	15	002.091.0050.1	VITE	SCREW	VIS	2
	16	012.280.0010.1	TASSELLO	SMALL BLOCK	PASTILLE DE BUTEE	2
	17	012.251.0370.1	CORONA EPICICLO	ANNULAR GEAR	COURONNE DENTEE	2
	18	012.111.0270.1	PORTA PLANETARI	SPIDER	PORTE-PLANETAIRES	2
	19	001.093.0440.0	VITE	SCREW	VIS	8
	20	012.270.0730.1	PERNO RUOTA PLANETARIA	PLANETARY GEAR PIN	AXE DE PLANETAIRE	8
	21	012.320.2910.1	DISTANZIALE	SPACER	ENTRETOISE	16
	22	001.010.0520.0	CUSCINETTO	BEARING	ROULEMENT	16
	23	012.250.4930.1	RUOTA SOLARE	SUN GEAR	ROUE SOLAIRE	8
	24	001.092.0010.0	VITE	SCREW	VIS	4
	25	001.159.0010.0	GUARNIZIONE	GASKET	JOINT	4
	26	001.151.0010.0	TAPPO	PLUG	BOUCHON	4
	27	001.115.0040.0	DADO	NUT	ECROU	20

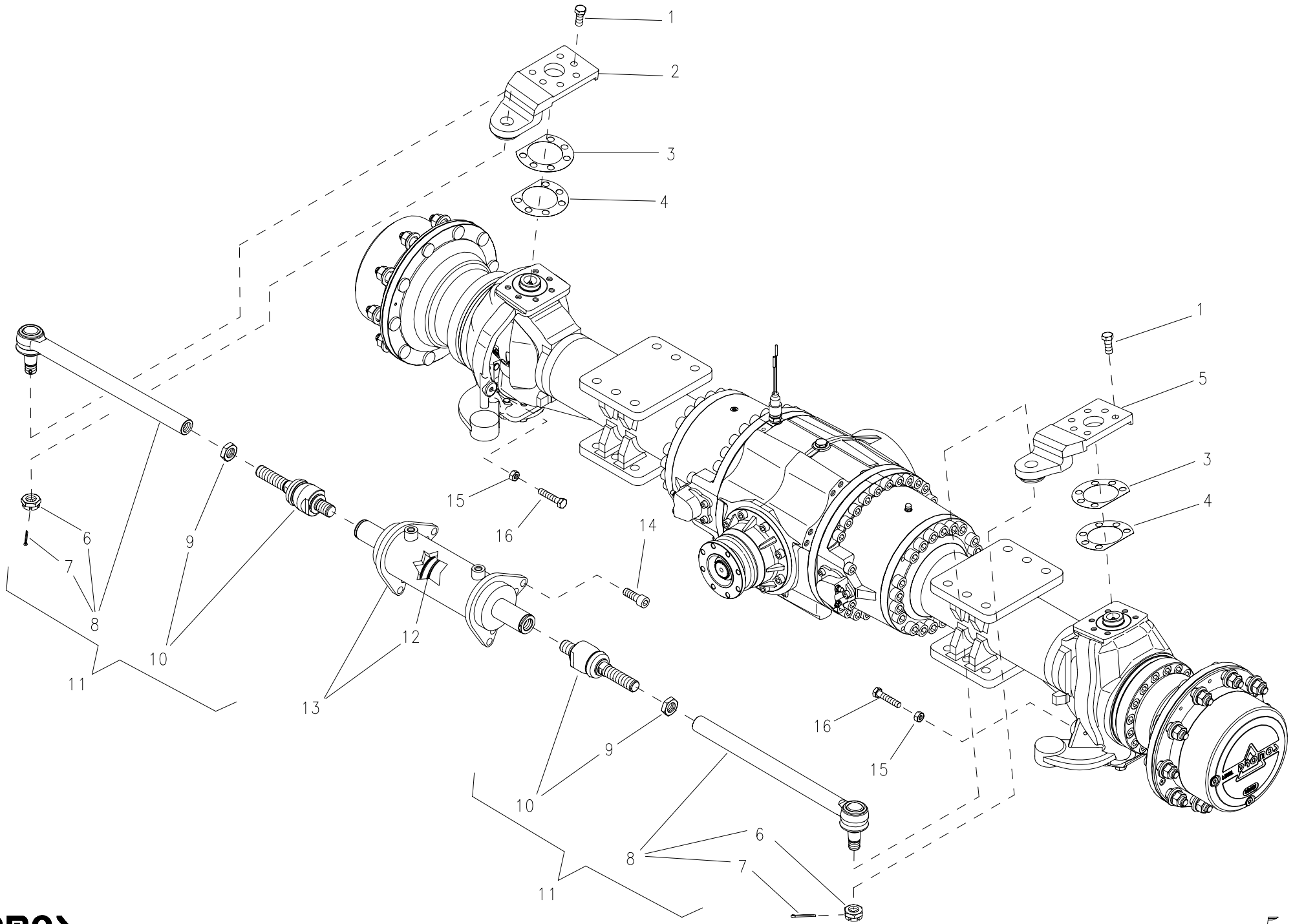

PMSF.42.78.0003

25-02-2015



PMSF.42.78.0003

Tab.	Item	Code	Descrizione	Description	Déscription	Qty
5						
	1	001.090.0020.0	VITE	SCREW	VIS	12
	2	012.340.0840.1	LEVA RINVIO	TRANSMISSION LEVER	LEVIER DE RENVOI	1
	3	012.312.0350.1	SPESSORE REGISTRO	SHIM	CALE DE REGLAGE	5
	4	012.312.0360.1	SPESSORE REGISTRO	SHIM	CALE DE REGLAGE	5
	5	012.340.0830.1	LEVA RINVIO	TRANSMISSION LEVER	LEVIER DE RENVOI	1
	6	001.110.0530.0	DADO	NUT	ECROU	2
	7	001.142.0060.0	COPIGLIA	SPLIT PIN	GOUPILLE	2
	8	001.412.0180.0	TESTA STERZO	BALL HEAD	TETE SPHERIQUE	2
	9	012.010.7700.1	DADO	NUT	ECROU	2
	10	001.410.0060.0	SNODO ASSIALE	AXIAL JOINT	ARTICULATION AXIALE	2
	11	001.411.0180.0	ASTA ASSIALE COMPLETA	COMPLETE CONTROL ROD	TIGE DE COMMANDE COMPLETE	2
	12	707.980.0300.0	KIT GUARNIZIONI	GASKETS KIT	KIT JOINTS	1
	13	012.600.0620.1	CILINDRO DOPPIO EFFETTO	DOUBLE-ACTING CYLINDER	CYLINDRE DOUBLE EFFET	1
	14	001.091.0240.0	VITE	SCREW	VIS	8
	15	001.110.0100.0	DADO	NUT	ECROU	2
	16	001.090.0850.0	VITE	SCREW	VIS	2



PMSF.42.78.0003

Code	Tab.	Item	Code	Tab.	Item	Code	Tab.	Item	Code	Tab.	Item	Code	Tab.	Item
001.004.0020.0	2	20	001.090.0020.0	3	12	001.151.0050.0	1	19	012.160.0910.1	3	8	012.312.0350.1	5	3
001.010.0520.0	4	22		5	1	001.155.0010.0	2	15	012.160.0920.1	3	1	012.312.0360.1	3	10
001.013.0040.0	4	3	001.090.0510.0	1	30	001.159.0010.0	4	25	012.180.0710.1	2	3		5	4
001.013.0290.0	1	8	001.090.0520.0	1	31	001.159.0040.0	1	20	012.190.0510.1	3	19	012.320.1220.1	1	14
001.013.0330.0	4	7	001.090.0850.0	5	16	001.180.0020.0	3	6	012.230.1240.1	1	3	012.320.1410.1	4	2
001.013.0420.0	1	16	001.091.0020.0	1	9	001.410.0060.0	5	10	012.231.2400.1	1	55	012.320.2910.1	4	21
001.013.0530.0	1	56	001.091.0140.0	1	34	001.411.0180.0	5	11	012.231.2590.1	2	21	012.320.2920.1	4	12
001.031.0020.0	1	2	001.091.0210.0	2	13	001.412.0180.0	5	8	012.240.0410.1	3	20	012.320.2970.1	1	60
001.033.0010.0	1	47	001.091.0240.0	3	23	001.430.0150.0	2	11	012.250.4920.1	4	13	012.321.0580.1	1	7
001.040.0010.0	3	16		5	14	001.440.0250.0	1	51	012.250.4930.1	4	23	012.340.0830.1	5	5
001.040.0130.0	1	37	001.091.0490.0	3	22	001.490.0060.0	1	52	012.250.4940.1	4	9	012.340.0840.1	5	2
001.040.0230.0	3	15	001.091.0690.0	1	61	002.091.0050.1	4	15	012.251.0370.1	4	17	012.351.0670.1	1	45
001.060.0030.0	3	17	001.091.0730.0	3	4	002.132.0020.1	4	14	012.262.0160.1	1	25	012.360.0120.1	4	4
001.060.0090.0	4	1	001.091.1340.0	4	11	002.132.0060.1	1	48	012.262.0170.1	1	27	012.370.0060.1	1	4
001.060.0780.0	1	5	001.091.1360.0	2	17	002.156.0010.1	1	21	012.270.0730.1	4	20	012.450.0080.1	1	1
001.061.0020.0	1	36	001.091.1370.0	2	16	003.010.0220.1	2	10	012.270.0740.1	3	11	012.450.0270.1	4	10
001.061.0050.0	4	6	001.092.0010.0	4	24	012.010.7610.1	1	38	012.270.0820.1	3	7	012.490.0310.1	1	39
001.061.0140.0	1	32	001.092.0080.0	1	53	012.010.7690.1	3	21	012.271.0040.1	1	28	012.540.0020.1	3	14
001.061.0310.0	1	15	001.093.0440.0	4	19	012.010.7700.1	5	9	012.272.0680.1	1	44	012.600.0620.1	5	13
001.061.0330.0	1	41	001.110.0100.0	5	15	012.010.7940.1	1	40	012.280.0010.1	4	16	707.950.0040.0	2	12
001.061.0340.0	2	2	001.110.0530.0	5	6	012.010.7950.1	1	35	012.300.0400.1	1	26	707.960.0080.0	2	8
001.061.0390.0	1	43	001.115.0040.0	4	27	012.030.1660.1	2	14	012.300.0410.1	1	23	707.970.0050.0	2	7
001.061.0630.0	1	42	001.132.0150.0	1	24	012.081.0050.1	2	5	012.310.0140.1	1	11	707.980.0300.0	5	12
001.061.0940.0	2	9	001.132.0220.0	2	4	012.082.0050.1	2	6	012.310.0150.1	1	12	808.010.1000.0	1	17
001.061.1410.0	3	3	001.132.0230.0	3	2	012.101.0390.1	4	5	012.310.0160.1	1	13	808.020.0150.0	1	22
001.062.0110.0	3	13	001.132.0370.0	1	54	012.111.0270.1	4	18	012.310.0340.1	1	49	909.050.0160.0	1	29
001.070.0200.0	2	19	001.133.0080.0	1	46	012.120.2310.1	1	62	012.310.0360.1	1	57			
001.071.0010.0	3	18	001.142.0060.0	5	7	012.120.2340.1	1	18	012.310.0370.1	1	58			
001.071.0430.0	2	22	001.150.0010.0	2	18	012.120.2600.1	1	33	012.310.0380.1	1	59			
001.081.0230.0	4	8	001.150.0020.0	2	1	012.120.2650.1	3	5	012.310.0680.1	1	50			
001.081.0280.0	1	6	001.151.0010.0	4	26	012.140.0460.1	1	10	012.312.0350.1	3	9			

DROMOS s.r.l.
www.dromos.com

Via Guido Rossa, 7 - località Monteveglio
40053 Valsamoggia (Bologna), Italia
Tel. +39 051 830600
Fax +39 051 830598