

Publication 478
April 2005
Part No. 41570.78
Revised: 30.10.14



1.6M MULTICUT FLAILHEAD

BELT DRIVE WITH 77HP PISTON MOTOR
Tri-Drive & Quad Drive Rotor Versions

Operation & Parts Manual

Build 7361803 and variants

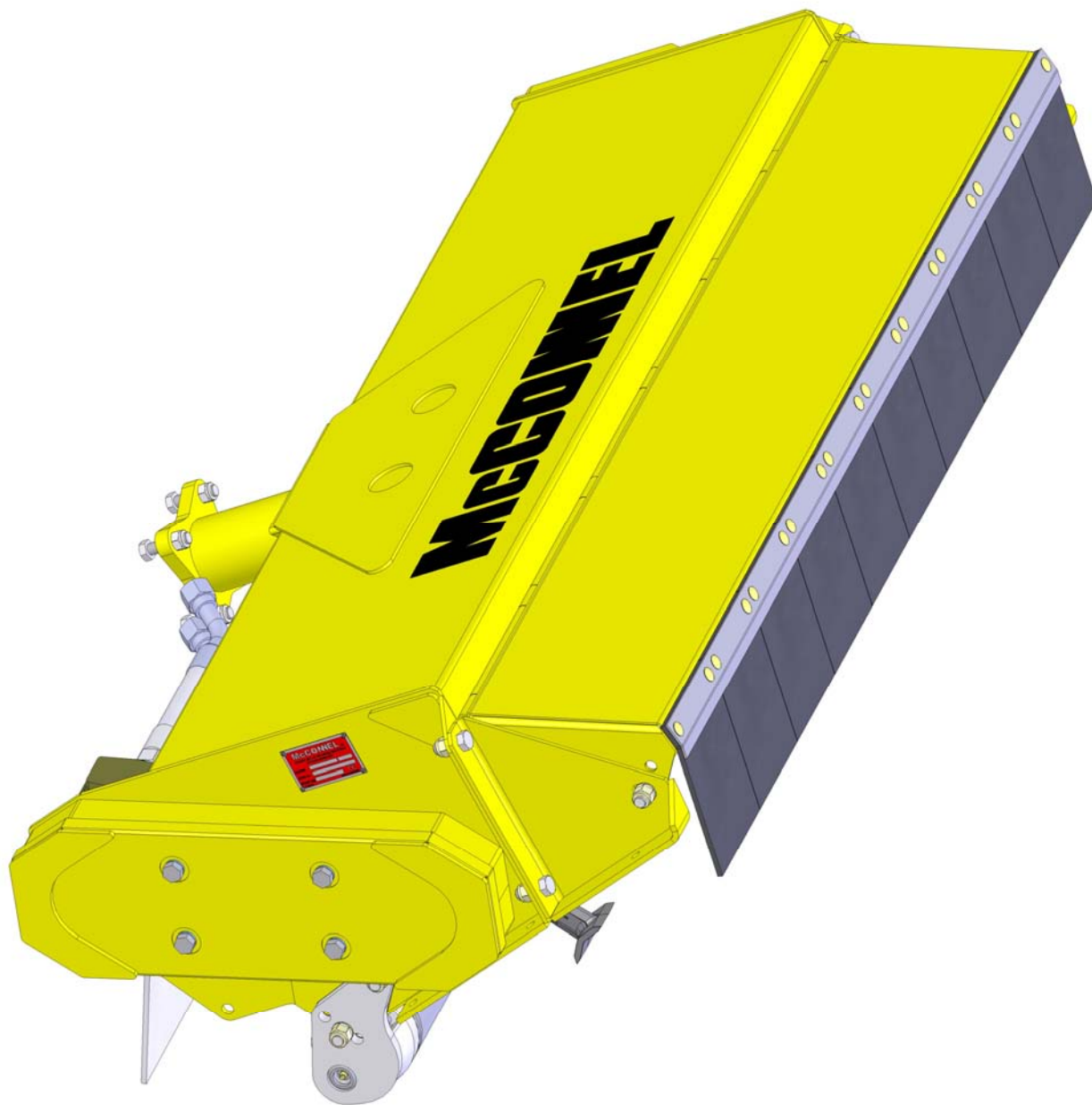

IMPORTANT

VERIFICATION OF WARRANTY REGISTRATION



Dealer Warranty Information & Registration Verification

It is imperative that the selling dealer registers this machine with McConnel Limited before delivery to the end user – failure to do so may affect the validity of the machine warranty.

To register machines; log onto <https://my.mcconnel.com> and select 'Machine Registration' which can be found in the 'Warranty' section of the site. **Confirm to the customer that the machine has been registered by completing the verification form below.**

Registration Verification	Serial No. <input type="text"/>
Dealer Name:	
Dealer Address:	
Customer Name:	
Date of Warranty Registration:/...../..... Dealer Signature:	

Note to Customer / Owner

Please ensure the section above has been completed and signed by the dealer to verify your machine has been registered with McConnel Limited.

IMPORTANT: During the initial 'bedding in' period of a new machine it is the customer's responsibility to regularly inspect all nuts, bolts and hose connections for tightness and re-tighten if required. New hydraulic connections occasionally weep small amounts of oil as the seals and joints settle in – where this occurs it can be cured by re-tightening the connection – *refer to torque settings chart below*. The tasks stated above should be performed on an hourly basis during the first day of work and at least daily thereafter as part of the machine's general maintenance procedure.

CAUTION: DO NOT OVER TORQUE HYDRAULIC FITTINGS AND HOSES

Torque Settings for Hydraulic Fittings

Hydraulic Hose Ends		
BSP	Setting	Metric
1/4"	18 Nm	19 mm
3/8"	31 Nm	22 mm
1/2"	49 Nm	27 mm
5/8"	60 Nm	30 mm
3/4"	80 Nm	32 mm
1"	125 Nm	41 mm
1.1/4"	190 Nm	50 mm
1.1/2"	250 Nm	55 mm
2"	420 Nm	70 mm

Port Adaptors with Bonded Seals		
BSP	Setting	Metric
1/4"	34 Nm	19 mm
3/8"	47 Nm	22 mm
1/2"	102 Nm	27 mm
5/8"	122 Nm	30 mm
3/4"	149 Nm	32 mm
1"	203 Nm	41 mm
1.1/4"	305 Nm	50 mm
1.1/2"	305 Nm	55 mm
2"	400 Nm	70 mm

WARRANTY POLICY

WARRANTY REGISTRATION

All machines must be registered, by the selling dealer with McConnel Ltd, before delivery to the end user. On receipt of the goods it is the buyer's responsibility to check that the Verification of Warranty Registration in the Operator's Manual has been completed by the selling dealer.

1. LIMITED WARRANTIES

- 1.01. *All mounted machines supplied by McConnel Ltd are warranted to be free from defects in material and workmanship from the date of sale to the original purchaser for a period of 12 months, unless a different period is specified.
All Self Propelled Machines supplied by McConnel Ltd are warranted to be free from defects in material and workmanship from the date of sale to the original purchaser for a period of 12 months or 1500 hours. Engine warranty will be specific to the Manufacturer of that unit.*
- 1.02. *All spare parts supplied by McConnel Ltd and purchased by the end user are warranted to be free from defects in material and workmanship from the date of sale to the original purchaser for a period of 6 months. All parts warranty claims must be supported by a copy of the failed part invoice to the end user. We cannot consider claims for which sales invoices are not available.*
- 1.03. *The warranty offered by McConnel Ltd is limited to the making good by repair or replacement for the purchaser any part or parts found, upon examination at its factory, to be defective under normal use and service due to defects in material or workmanship. Returned parts must be complete and unexamined. Pack the component(s) carefully so that any transit damage is avoided. All ports on hydraulic items should be drained of oil and securely plugged to prevent seepage and foreign body ingress. Certain other components, electrical items for example, may require particular care when packing to avoid damage in transit.*
- 1.04. *This warranty does not extend to any product from which McConnel Ltd's serial number plate has been removed or altered.*
- 1.05. *The warranty policy is valid for machines registered in line with the terms and conditions detailed and on the basis that the machines do not extend a period of 24 months or greater since their original purchase date, that is the original invoice date from McConnel Limited.
Machines that are held in stock for more than 24 months cannot be registered for warranty.*
- 1.06. *This warranty does not apply to any part of the goods, which has been subjected to improper or abnormal use, negligence, alteration, modification, fitment of non-genuine parts, accident damage, or damage resulting from contact with overhead power lines, damage caused by foreign objects (e.g. stones, iron, material other than vegetation), failure due to lack of maintenance, use of incorrect oil or lubricants, contamination of the oil, or which has served its normal life. This warranty does not apply to any expendable items such as blades, belts, clutch linings, filter elements, flails, flap kits, skids, soil engaging parts, shields, guards, wear pads, pneumatic tyres or tracks.*
- 1.07. *Temporary repairs and consequential loss - i.e. oil, downtime and associated parts are specifically excluded from the warranty.*
- 1.08. *Warranty on hoses is limited to 12 months and does not include hoses which have suffered external damage. Only complete hoses may be returned under warranty, any which have been cut or repaired will be rejected.*
- 1.09. *Machines must be repaired immediately a problem arises. Continued use of the machine after a problem has occurred can result in further component failures, for which McConnel Ltd cannot be held liable, and may have safety implications.*
- 1.10. *If in exceptional circumstances a non McConnel Ltd part is used to effect a repair, warranty reimbursement will be at no more than McConnel Ltd's standard dealer cost for the genuine part.*

- 1.11. *Except as provided herein, no employee, agent, dealer or other person is authorised to give any warranties of any nature on behalf of McConnell Ltd.*
- 1.12. *For machine warranty periods in excess of 12 months the following additional exclusions shall apply:*
 - 1.12.1. *Hoses, exposed pipes and hydraulic tank breathers.*
 - 1.12.2. *Filters.*
 - 1.12.3. *Rubber mountings.*
 - 1.12.4. *External electric wiring.*
 - 1.12.5. *Bearings and seals*
 - 1.12.6. *External Cables, Linkages*
 - 1.12.7. *Loose/Corroded Connections, Light Units, LED's*
 - 1.12.8. *Comfort items such as Operator Seat, Ventilation, Audio Equipment*
- 1.13. *All service work, particularly filter changes, must be carried out in accordance with the manufacturer's service schedule. Failure to comply will invalidate the warranty. In the event of a claim, proof of the service work being carried out may be required.*
- 1.14. *Repeat or additional repairs resulting from incorrect diagnosis or poor quality previous repair work are excluded from warranty.*

NB Warranty cover will be invalid if any non-genuine parts have been fitted or used. Use of non-genuine parts may seriously affect the machine's performance and safety. McConnell Ltd cannot be held responsible for any failures or safety implications that arise due to the use of non-genuine parts.

2. REMEDIES AND PROCEDURES

- 2.01. *The warranty is not effective unless the Selling Dealer registers the machine, via the McConnell web site and confirms the registration to the purchaser by completing the confirmation form in the operator's manual.*
- 2.02. *Any fault must be reported to an authorised McConnell Ltd dealer as soon as it occurs. Continued use of a machine, after a fault has occurred, can result in further component failure for which McConnell Ltd cannot be held liable.*
- 2.03. *Repairs should be undertaken within two days of the failure. Claims submitted for repairs undertaken more than 2 weeks after a failure has occurred, or 2 days after the parts were supplied will be rejected, unless the delay has been authorised by McConnell Ltd. Please note that failure by the customer to release the machine for repair will not be accepted as a reason for delay in repair or submitting warranty claims.*
- 2.04. *All claims must be submitted, by an authorised McConnell Ltd Service Dealer, within 30 days of the date of repair.*
- 2.05. *Following examination of the claim and parts, McConnell Ltd will pay, at their discretion, for any valid claim the invoiced cost of any parts supplied by McConnell Ltd and appropriate labour and mileage allowances if applicable.*
- 2.06. *The submission of a claim is not a guarantee of payment.*
- 2.07. *Any decision reached by McConnell Ltd. is final.*

3. LIMITATION OF LIABILITY

- 3.01. *McConnell Ltd disclaims any express (except as set forth herein) and implied warranties with respect to the goods including, but not limited to, merchantability and fitness for a particular purpose.*
- 3.02. *McConnell Ltd makes no warranty as to the design, capability, capacity or suitability for use of the goods.*
- 3.03. *Except as provided herein, McConnell Ltd shall have no liability or responsibility to the purchaser or any other person or entity with respect to any liability, loss, or damage caused or alleged to be caused directly or indirectly by the goods including, but not limited to, any indirect, special, consequential, or incidental damages resulting from the use or operation of the goods or any breach of this warranty. Notwithstanding the above limitations and warranties, the manufacturer's liability hereunder for damages incurred by the purchaser or others shall not exceed the price of the goods.*
- 3.04. *No action arising out of any claimed breach of this warranty or transactions under this warranty may be brought more than one (1) year after the cause of the action has occurred.*

4. MISCELLANEOUS

- 4.01. McConnel Ltd may waive compliance with any of the terms of this limited warranty, but no waiver of any terms shall be deemed to be a waiver of any other term.*
- 4.02. If any provision of this limited warranty shall violate any applicable law and is held to be unenforceable, then the invalidity of such provision shall not invalidate any other provisions herein.*
- 4.03. Applicable law may provide rights and benefits to the purchaser in addition to those provided herein.*

McConnel Limited

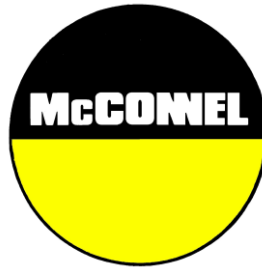

For Safety and Performance...

ALWAYS READ THE BOOK FIRST

McCONEL LIMITED

**Temeside Works
Ludlow
Shropshire
England**

**Telephone: +44 (0)1584 873131
www.mcconel.com**

- NOISE STATEMENT -

The equivalent daily personal noise exposure from this machine measured at the operators' ear is within the range 78 – 85 dB, these figures apply to a normal distribution of use where the noise fluctuates between zero and maximum. The figures assume that the machine is fitted to a tractor with a 'quiet' cab with the windows closed in a generally open environment. We recommend that the windows are kept closed. With the cab rear window open the equivalent daily personal noise exposure will increase to a figure within the range 82 – 88 dB. At an equivalent daily noise exposure level of 85 – 90 dB ear protection is recommended and must always be used if any window is left open.



Operating, servicing and maintaining this equipment can expose you to chemicals including gasoline, diesel fuel, lubricants, petroleum products, engine exhaust, carbon monoxide, and phthalates, which are known to the State of California to cause cancer and birth defects or other reproductive harm. To minimize exposure, avoid breathing exhaust, do not idle the engine except as necessary, service your vehicle in a well-ventilated area and wear gloves or wash your hands frequently when servicing your vehicle. Battery posts, terminals and related accessories contain lead and lead compounds, chemicals known to the state of California to cause cancer, birth defects or other reproductive harm. For more information go to www.P65Warnings.ca.gov. This website, operated by California's Office of Environmental Health Hazard Assessment, provides information about these chemicals and how individuals may be exposed to them.

GENERAL INFORMATION

Always read this manual before fitting or operating the machine – whenever any doubt exists contact your dealer or the McConnel Service Department for advice and assistance.

Use only McConnel Genuine Service Parts on McConnel Equipment and Machines

DEFINITIONS – *The following definitions apply throughout this manual:*

WARNING

An operating procedure, technique etc., which –
can result in personal injury or loss of life if not observed carefully.

CAUTION

An operating procedure, technique etc., which –
can result in damage to either machine or equipment if not observed carefully.

NOTE

An operating procedure, technique etc., which –
is considered essential to emphasis.

LEFT AND RIGHT HAND

This term is applicable to the machine when attached to the tractor and is viewed
from the rear – this also applies to tractor references.

MACHINE & DEALER INFORMATION

Record the Serial Number of your machine on this page and always quote this number when ordering parts. Whenever information concerning the machine is requested remember also to state the make and model of tractor to which the machine is fitted.

Machine Serial Number:	Installation Date:
Machine Model details:	
Dealer Name:	
Dealer Address:	
Dealer Telephone No:	
Dealer Email Address:	

FLAILHEAD CHECKS

Ensure that all bolts in the locations indicated below are tightened to the torque figures stated.

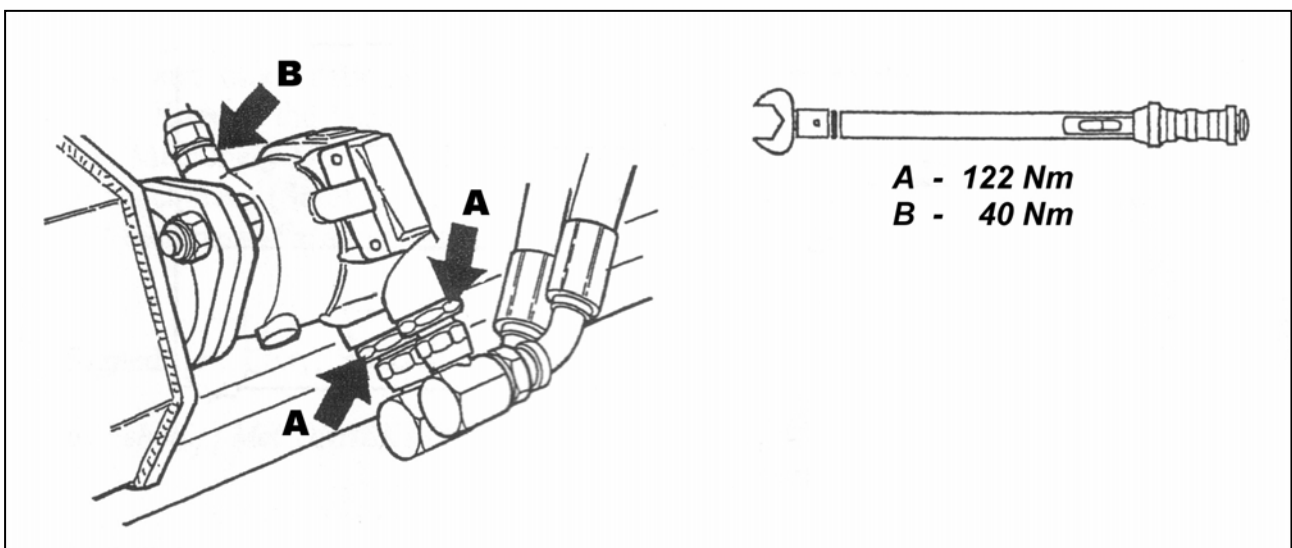
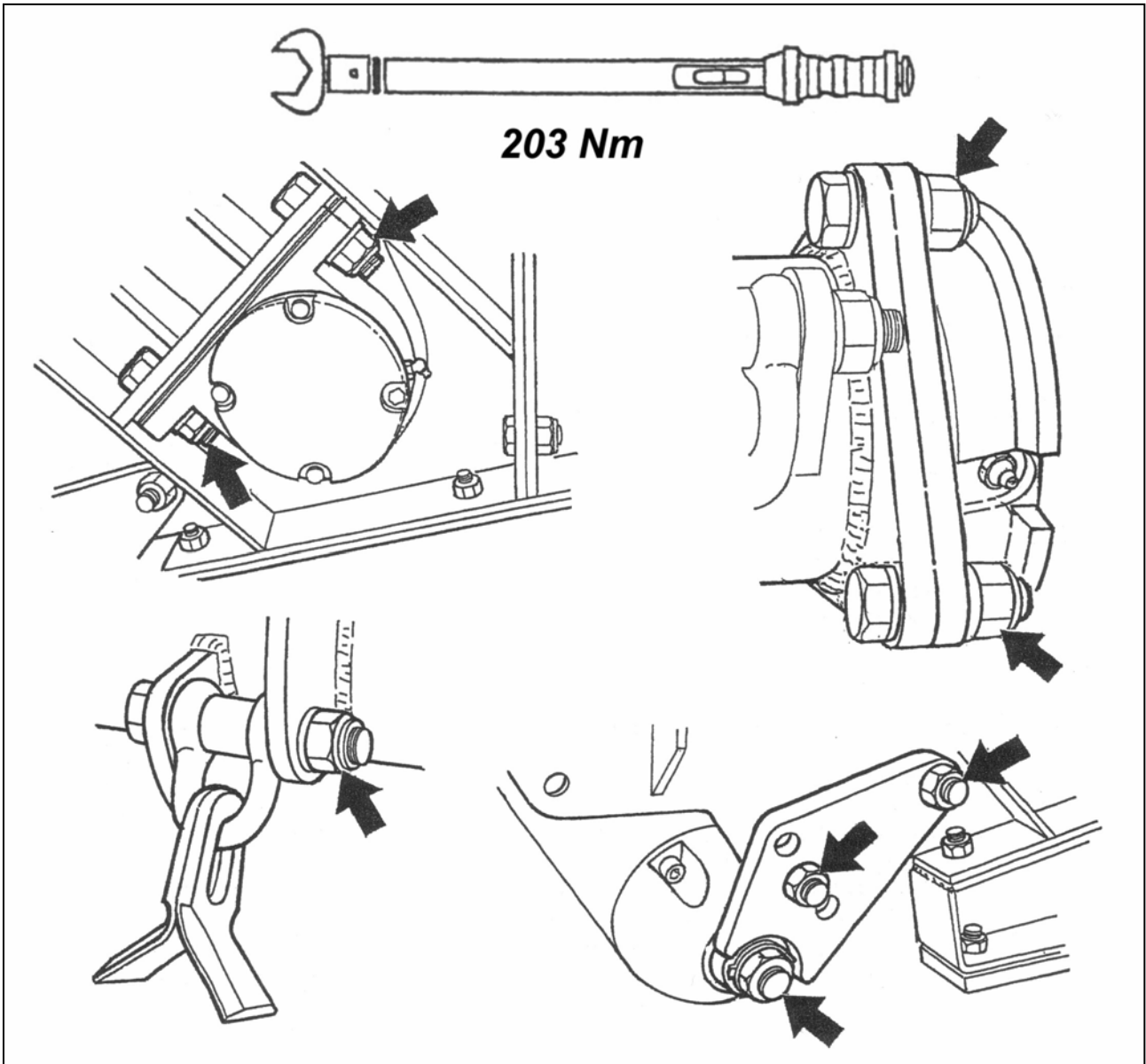

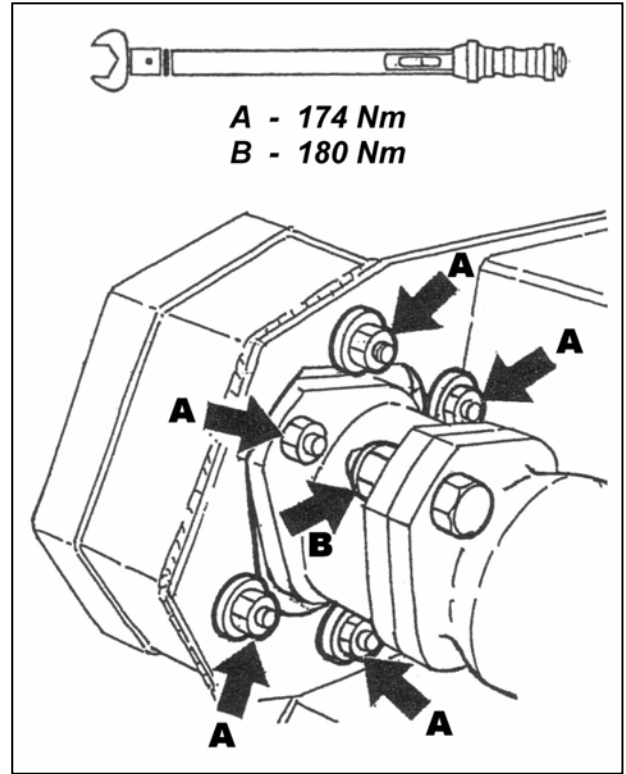
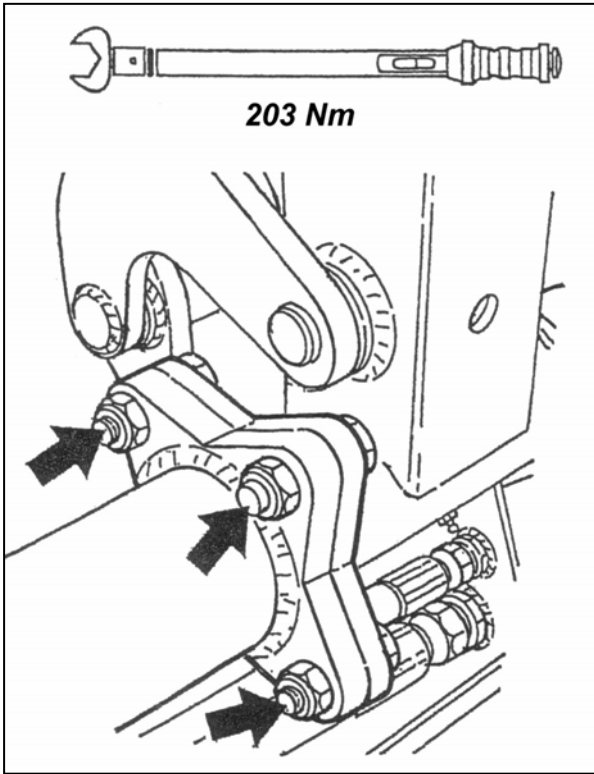

BELT TENSION

Checking Belt Tension

Belt tension is correct when: 'comfortable' finger pressure exerted on the belt at the mid-way point between the pulleys causes the tooth tips of the belt to be deflected downwards to the level of the thick red line on the belt tension decal – see *diagram opposite*.

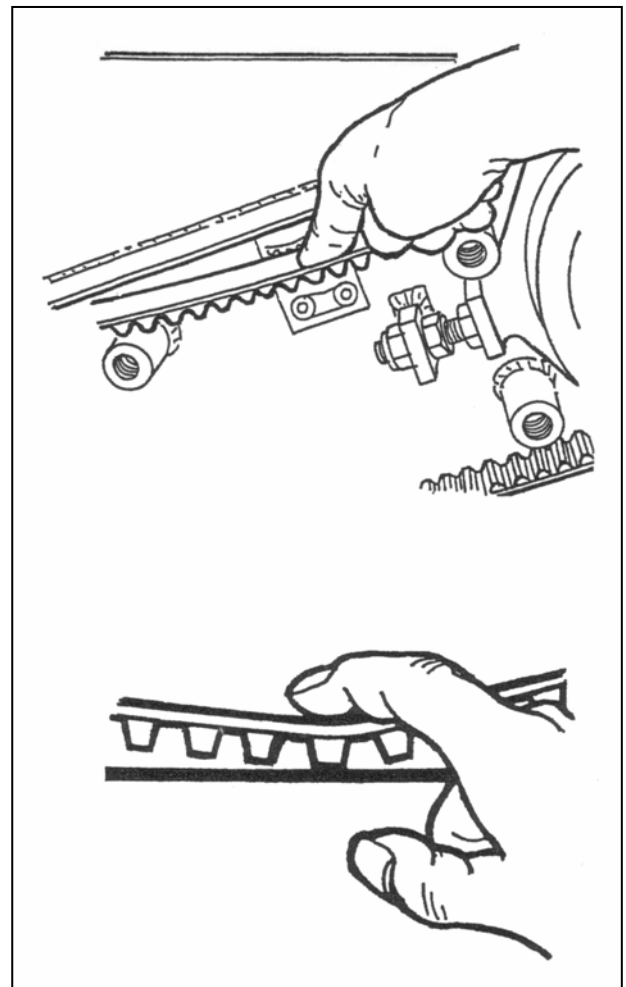

PULLEYS

Pulley Alignment

The diagrams opposite illustrate correct and incorrect alignment of the flailhead belt.

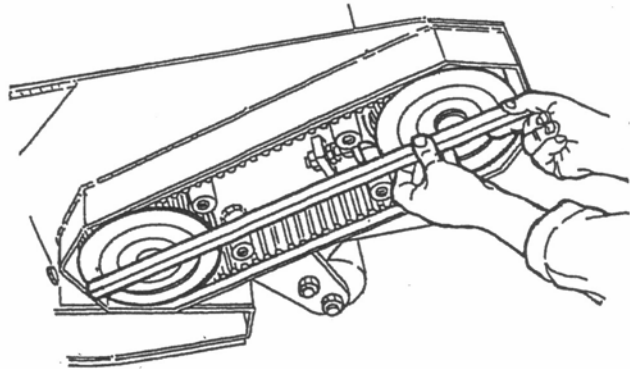

A – Correct:
Belt aligned.

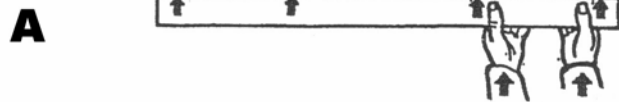

B – Incorrect:
Angular misalignment of the belt.

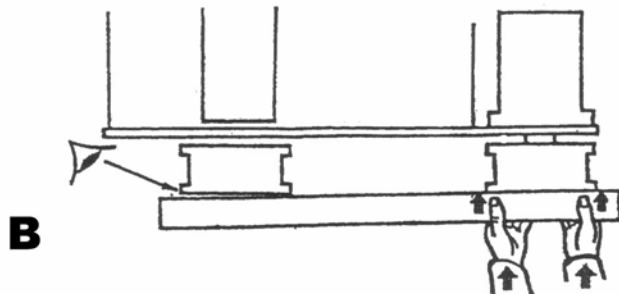

C – Incorrect:
Parallel misalignment of the belt.

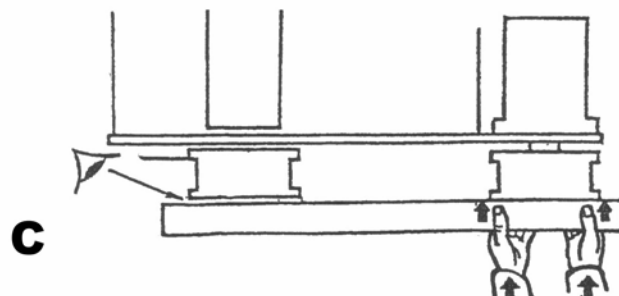

ALIGNMENT PROCEDURE

Belt pulleys must be correctly aligned at all times to avoid excessive belt wear or damage. Alignment of the pulleys is achieved by the use of shims placed between the rotor's free end bearing housing and its mounting position on the casing assembly; adding or removing shims allows angular adjustment of the rotor shaft and pulley so it can be correctly aligned with the motor drive pulley. Shims are available in 2mm and 3mm thicknesses, the quantity used will be the number required only to achieve accurate alignment.

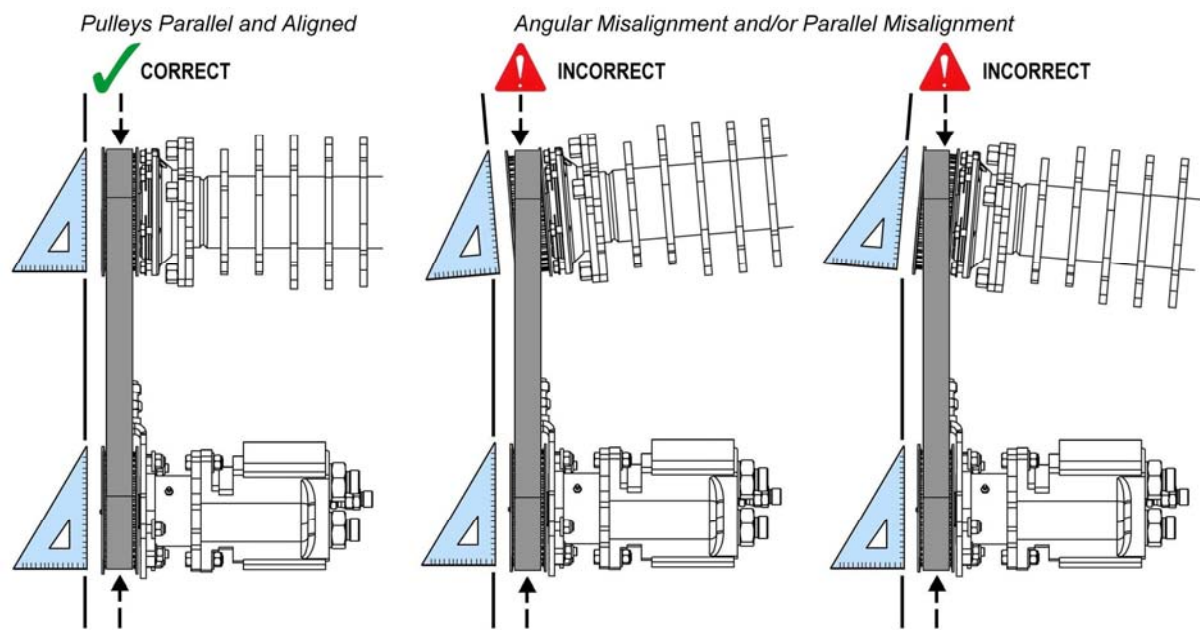
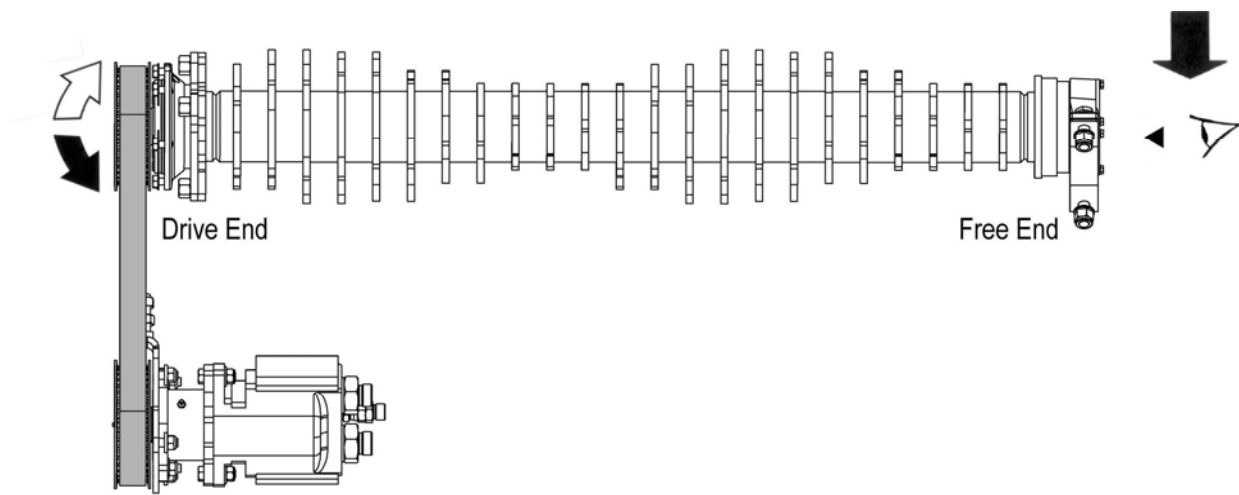
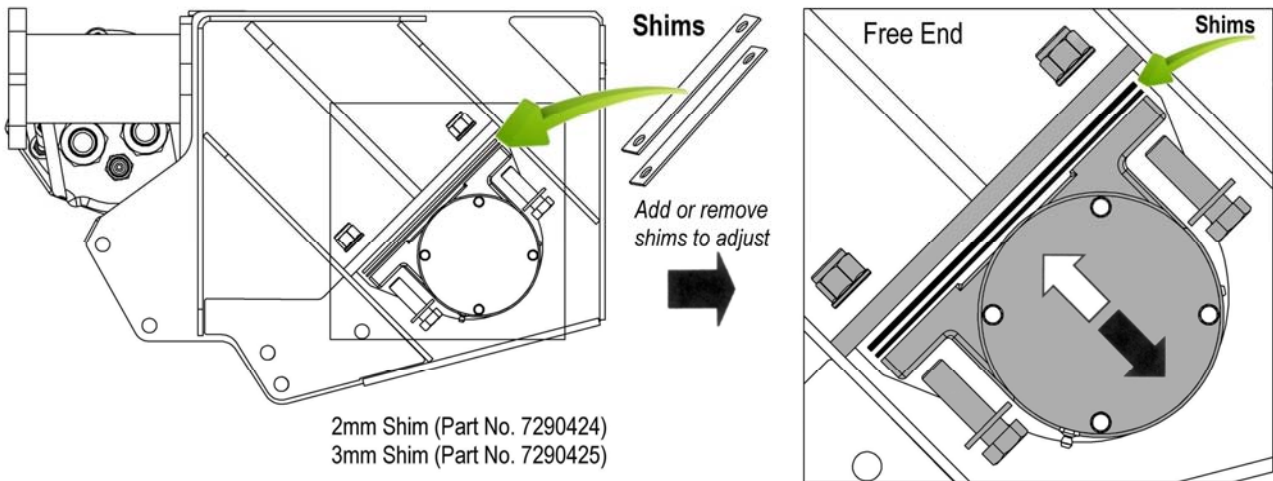

Drive Pulley

In extreme cases of pulley mis-alignment where adjustment of the rotor pulley alone does not align the pulleys correctly, additional adjustment can be made by placing shimming washers between the motor plate and the flail head casing as illustrated below.

The placement of the washers will depend on which direction adjustment is needed but will either be on the outermost pair of bolts or the innermost; in either case an equal number of washers should be used.

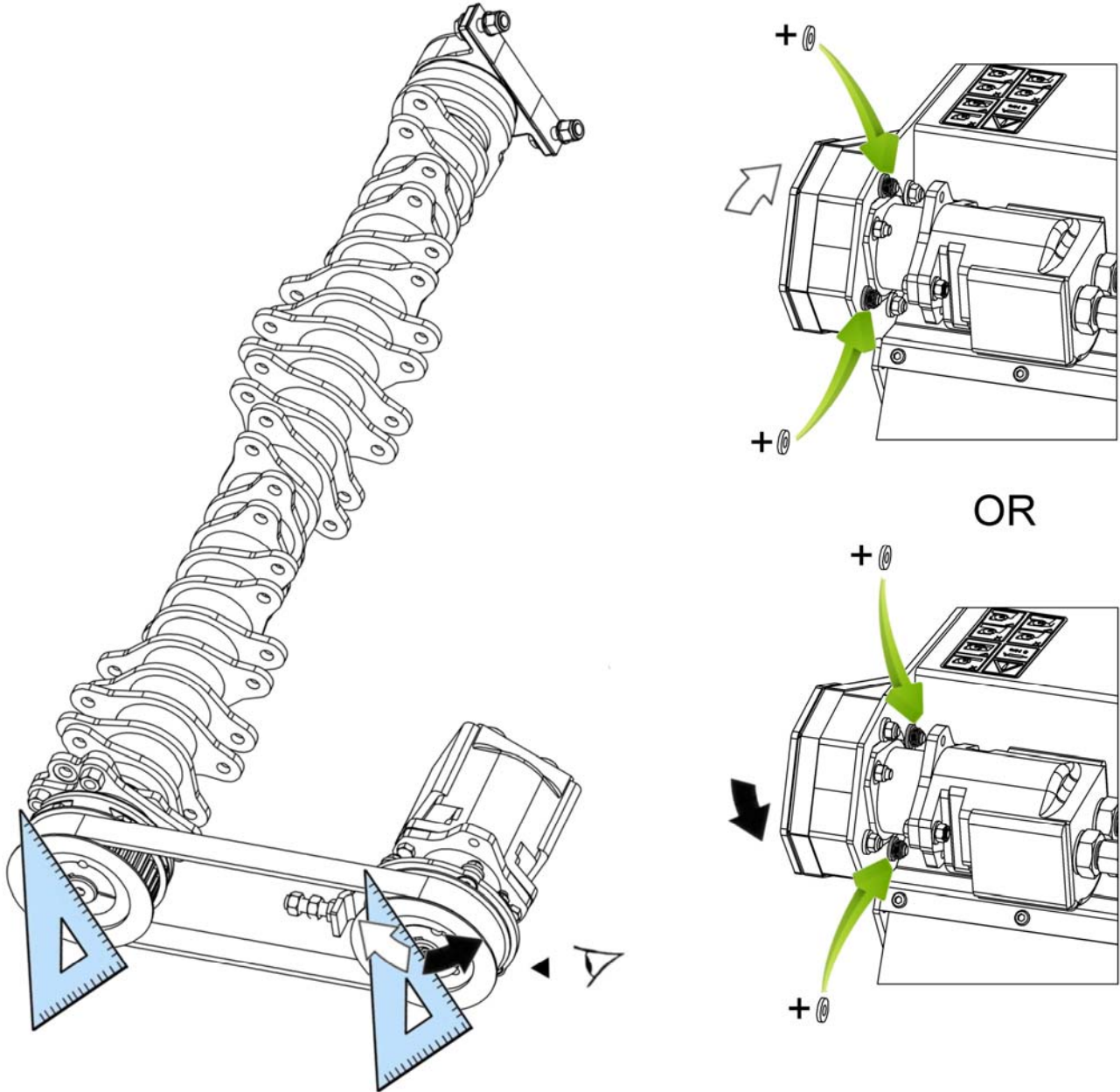

When pulleys have been correctly aligned the belt tension should be checked and if required adjusted to the correct tension; refer to belt adjustment section for details of belt tensioning procedure.

ROTOR SHAFT ALIGNMENT

Rotor shaft hub failure can usually be attributed to rotor misalignment caused by distortion of the flailhead due to the hood or casing receiving a violent blow against an obstruction during work or by dropping the flail head heavily to the ground. These actions should, wherever possible, be avoided.

Where rotor alignment is incorrect or when refitting or replacing rotor components it is imperative that the following procedure for re-assembly is adhered to:

Procedure for re-assembly is as follows:-

1. Press the new bearing fully into the housing and then press the complete assembly onto the rotor shaft until the bearing inner race is firmly against the rotor shoulder.
2. Support the head off the ground in a vertical position. Offer up the complete rotor shaft into the casing, and locate the lower mounting bolts. Tighten the nuts sufficiently to take out all movement and then check the hole alignment at the top end of the casing. If the mounting bolts will not readily fit into place, release the lower bolts and shim between the casing boss and bearing housing until the top holes are aligned.
3. Locate the three top mounting bolts and then tighten the three lower bolts and nuts completely – *torque to a setting of approximately 162Nm (120 ft-lb.)*.
4. Check for clearance between the top bearing housing and casing, and completely shim all gaps before tightening the three mounting bolts to the same torque as above. If there is not clearance between the housing and casing, the bosses will need to be 'ground off' in order to provide clearance for the adding of shims. *Failure to shim all gaps will tend to draw the bearing from the shaft when the bolts are tightened.*

Note

Two sizes of shim are available from McConnel; these are:

Part No. 8121043 for 0.4mm (.015")

Part No. 8121044 for 0.6mm (.025")

Alternatively thin spacing washers .2 may be used. The welded bosses in the casing may be of varying depths - this is a jiggging requirement during manufacture of the head and should not be regarded as a fault.

5. Finally, with the flail head horizontal, turn the rotor over by hand. There should be no binding or tight spots. Replace motor but do not bolt in place, when the rotor is rotated by hand the motor should not move. Movement up and down or side to side indicates a problem.

Warning: Failure to correctly align the rotor shaft may result in the motor shaft breaking.

6. The Coupling should be fitted on to the Motor and the nut tightened to a maximum torque setting of 80Nm (60 ft-lb.) - Do not exceed this value. Prior to the fitting of the motor, the hub and coupling splines should be liberally coated with Morris's K65M S high temperature grease, or equivalent. Experience has indicated that in addition to the pre-pack with Morris's K64M S grease supplied, greasing the rotor bearings, particularly the drive side, twice daily can considerably improve the longevity of the drive hub and coupling.

Rotor Shaft Shim Fitment

Rotor mis-aligned

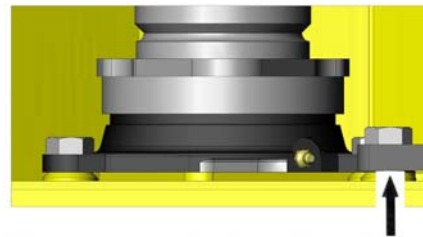
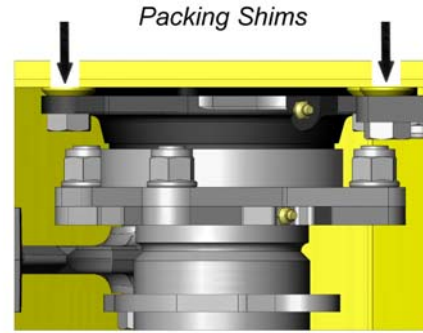
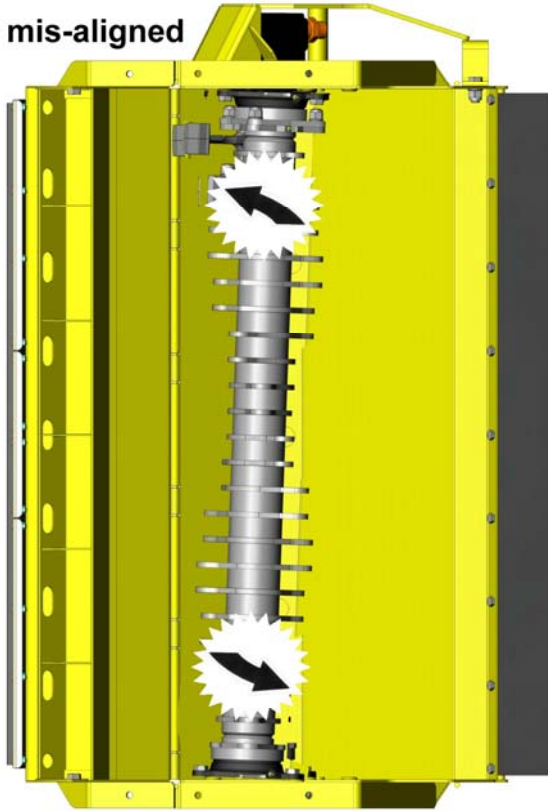

Rotor aligned

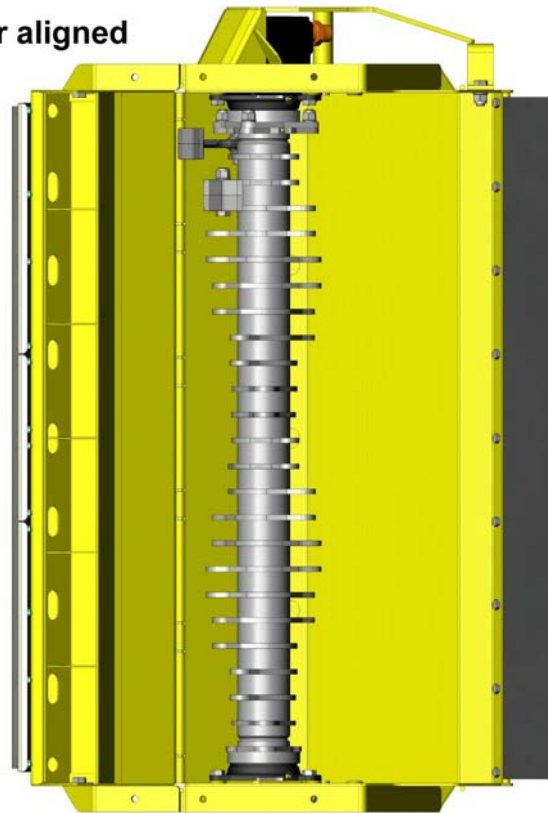

OPERATION

CUTTING – Material Thickness Limitations

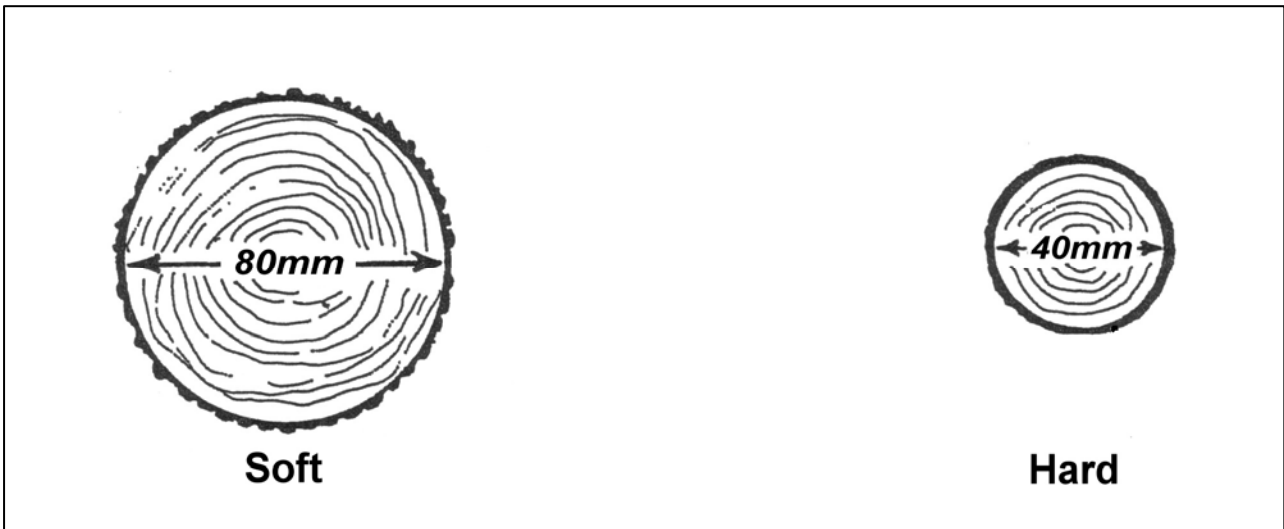

FLAIL SELECTION

There are four different types of flail available each with differing characteristics that provide optimum cutting performance for specific tasks – these are as follows:

- **F10 Grass Flail**
Designed specifically for general mowing activities.
- **Universal Boot Flail**
Designed for general purpose work – they are suitable for both mowing and cutting hedges with up to two-years growth.
- **F10H & Competition Flails**
Designed specifically for heavy-duty hedge cutting - capable of dealing with material up to 75 – 80mm diameter. These flails also provide a good mowing finish but will require considerably more power when used for this purpose.

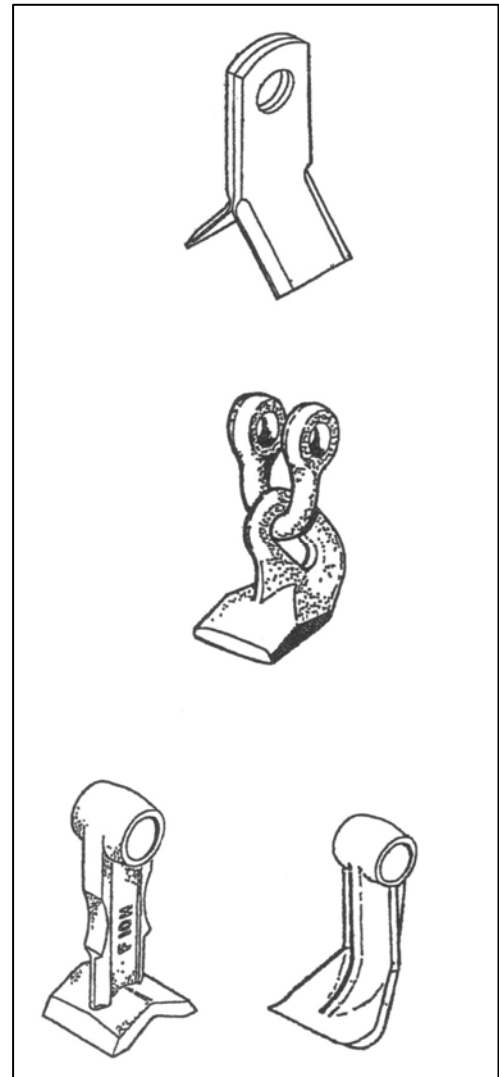

ROLLERS

Roller Positions

A combination of the three holes in the roller bracket and two holes in the flailhead casing allows a total of six possible roller height positions to be achieved.

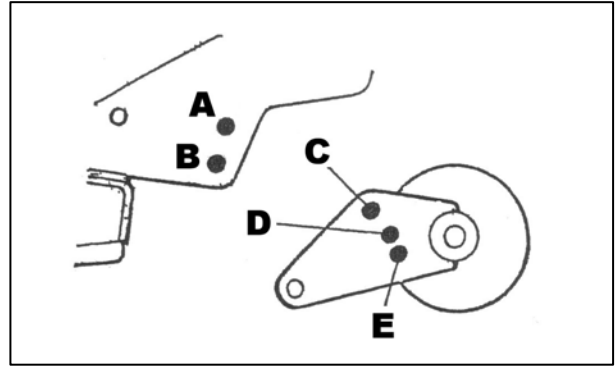

Roller Adjustment

Loosen only the roller bracket pivot bolts 'A' – see illustration opposite – support the roller to take the weight off it and undo and remove the bracket location bolts 'B' from both ends of the roller. Raise or lower the roller to the desired height position and replace the bolts. Tighten and torque all four nuts and bolts to 203 Nm.

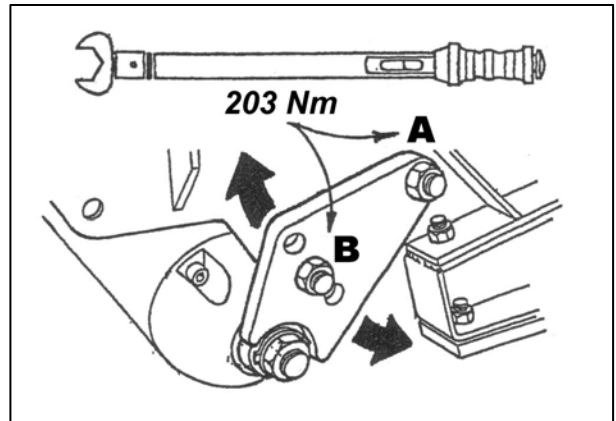

WARNING
Never operate the machine without a roller or with the roller incorrectly positioned.

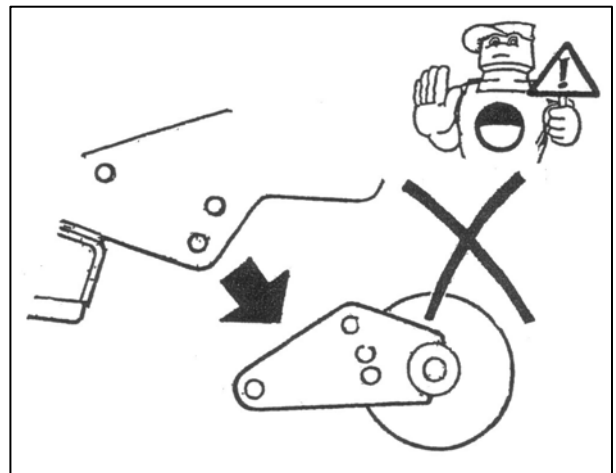

Roller Position 1.

- Roller position for hedge cutting.

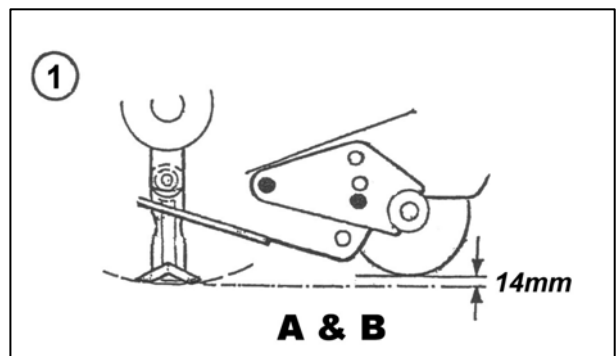

Roller Position 2, 3, 4, 5 & 6.

- Provides a selection of roller heights suitable for mowing operations – the length of the finish required and the ground surface condition will determine the selected setting.

Note: The dimensions shown on relation to the rotor tips are approximate only and may vary slightly depending on the type of flail fitted.

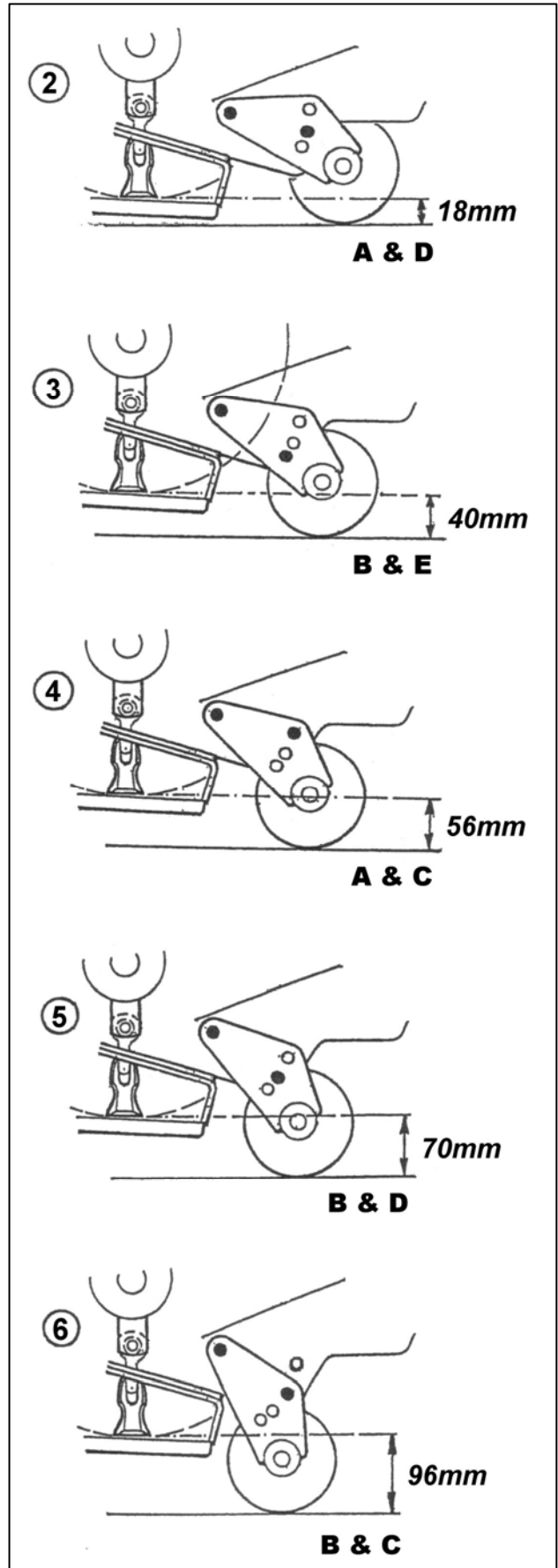

HEDGE CUTTING - Average working conditions with hedge or universal head.

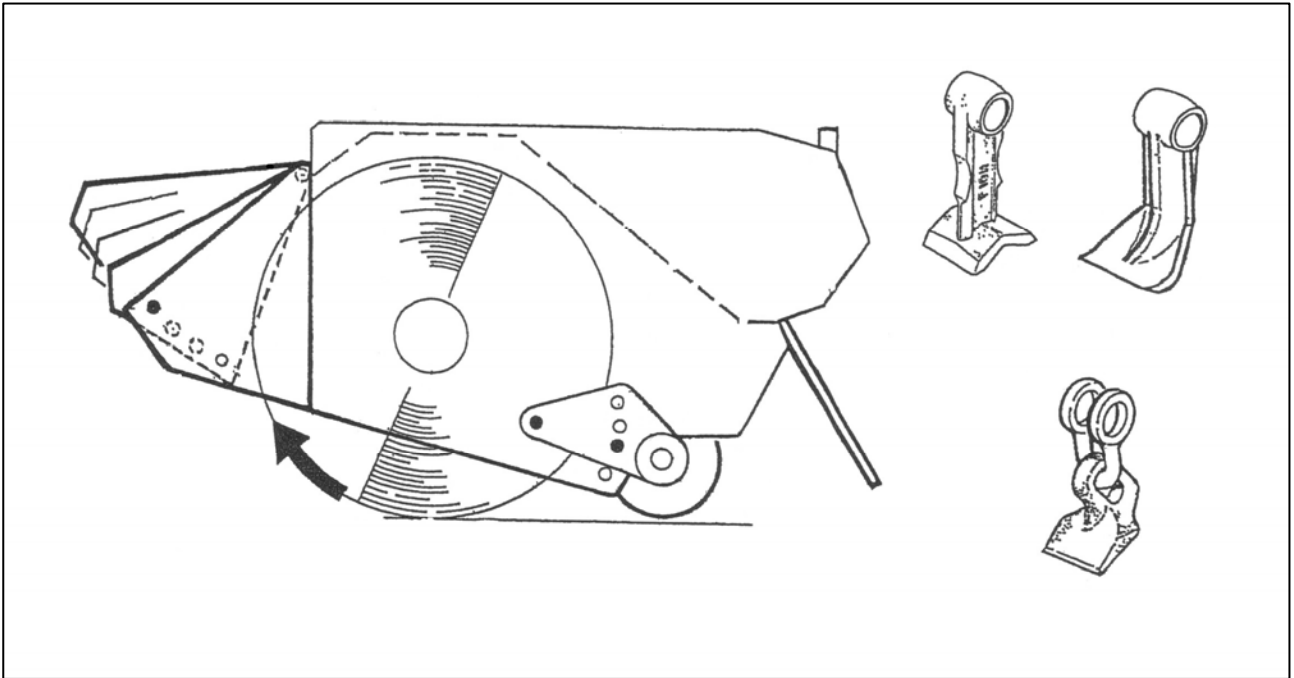

For the best finish the rotor should cut with 'upward' rotation. The roller should be set slightly above the rotor - *i.e. in position 1.*

On Universal heads the front rubber flaps (and skids if fitted) may be removed to aid entry into the flailhead of the material to be cut.

The front hood has four adjustment positions for height – *the lowest position that will allow material into the flailhead to be cut should always be selected.*

WARNING

Raising the front hood increases the possibility of debris escaping. **NEVER** operate the machine with the front hood set any higher than is absolutely necessary.

WARNING

DO NOT remove any guarding under any circumstances during operation.

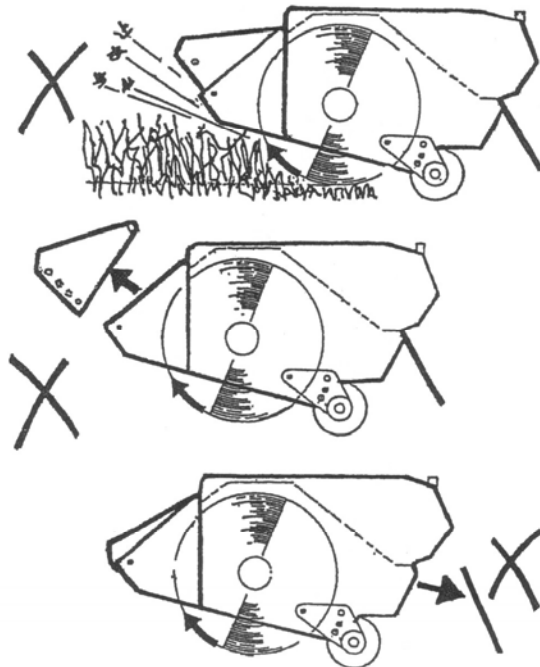
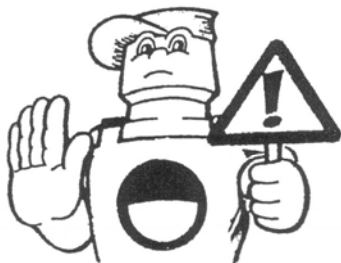

HEDGE CUTTING – Heavy-Duty working conditions with hedge head.

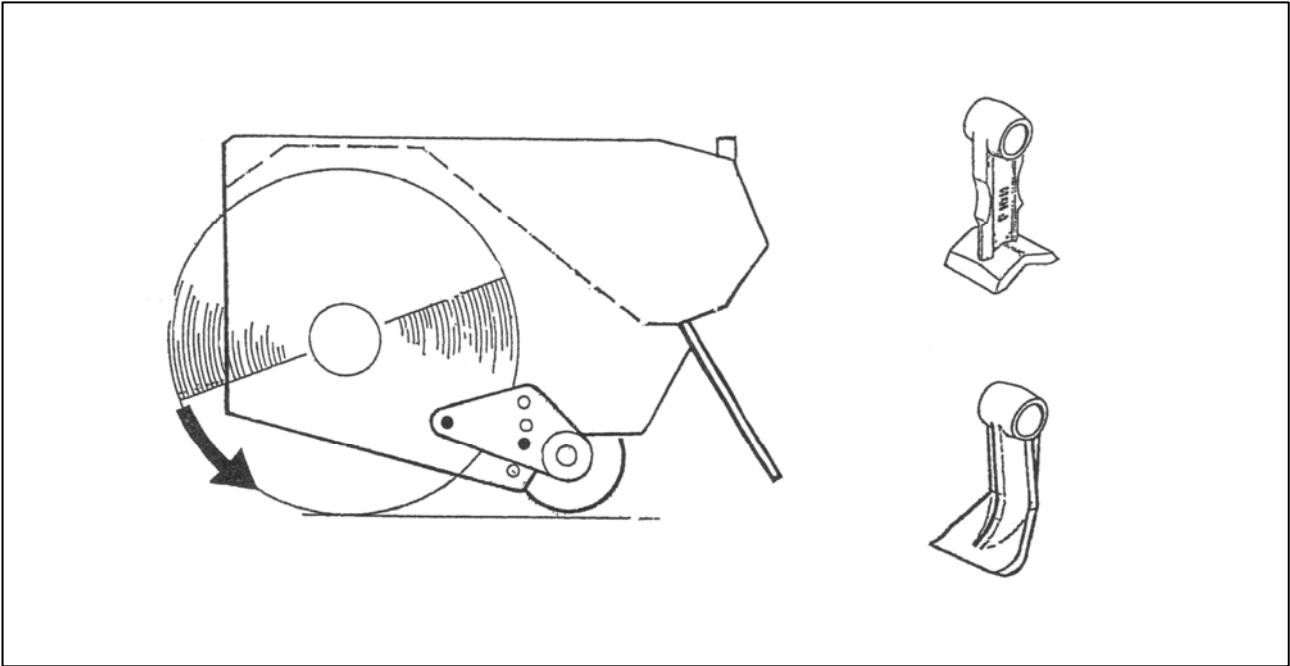

Where the size of the material to be cut makes it necessary for the front hood and carrier plates to be removed to allow the rotor to cut, the rotor must always be set to cut with 'downward' rotation – *this will result in a poorer finish and requires more power than 'upward' cutting.* The roller should be set slightly above the rotor - *i.e. in position 1.*

WARNING

DO NOT remove any guarding under any circumstance during operation.

The warning section contains two illustrations. On the left, a cartoon character with a worried expression holds a large triangular warning sign with an exclamation mark. On the right, a diagram shows the hedge trimmer head with an arrow pointing to a cut piece of material. A large 'X' is drawn over the cut piece, indicating that this method of cutting is incorrect or dangerous.

FLAILHEAD ARRANGEMENT

Mowing with Grass or Universal Head.

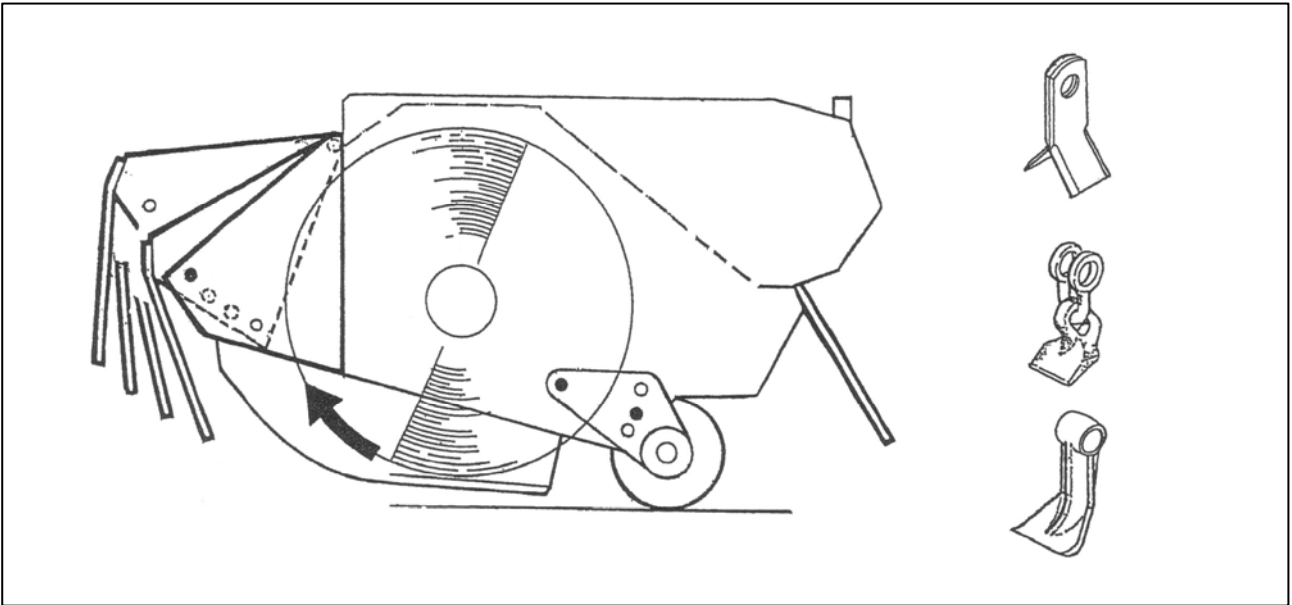

When mowing the rotor must always cut with 'upwards' rotation and the roller must always be set below the level of the skid (or the rotor if skids are not fitted) – *i.e. positions 2 - 6.* The front hood has four adjustment positions for height – *the lowest position that will allow material into the flailhead to be cut should always be selected.*

<p>WARNING Raising the front hood increases the possibility of debris escaping. NEVER operate the machine with the front hood set any higher than is absolutely necessary.</p>	
<p>WARNING DO NOT remove any guarding under any circumstances during operation.</p>	

FLAILHEAD

DANGER

Never approach or attempt to inspect a flailhead whilst it is running – switch off the machine and tractor and remove the key – wait for the rotor to come to a standstill before approaching.

Frequently inspect the rotor assembly for damaged or missing flails. Bolts and nuts that secure the flails to the rotor should be regularly checked and kept tight. The correct torque setting for these locknuts is 203 Nm. (150 lbf/ft.). Use only the correct flail bolt and locking nut. Check the flail pivot bushes for possible damage or wear – *they do not require oiling.*

Never attempt to run the rotor with flails missing – imbalance will cause severe vibration and can rapidly damage the rotor shaft bearings. As an emergency measure only, where a flail is broken off or missing the removal of another from the opposite side of the rotor will help to retain the balance of the rotor until the flails can be replaced – *this should be at the earliest possible opportunity.* Always replace flails in opposite pairs and never match up a new flail with a re-sharpened one – *the latter would be lighter.*

Blunt flails absorb a lot of power and leave an untidy finish to the work – *they should be sharpened periodically on a grindstone or with a portable grinder, always wear protective gear when sharpening flails.*

Ensure that the bearing housings and hydraulic mounting nuts and bolts are kept tight at all times – *they should be checked during servicing and when performing maintenance.*

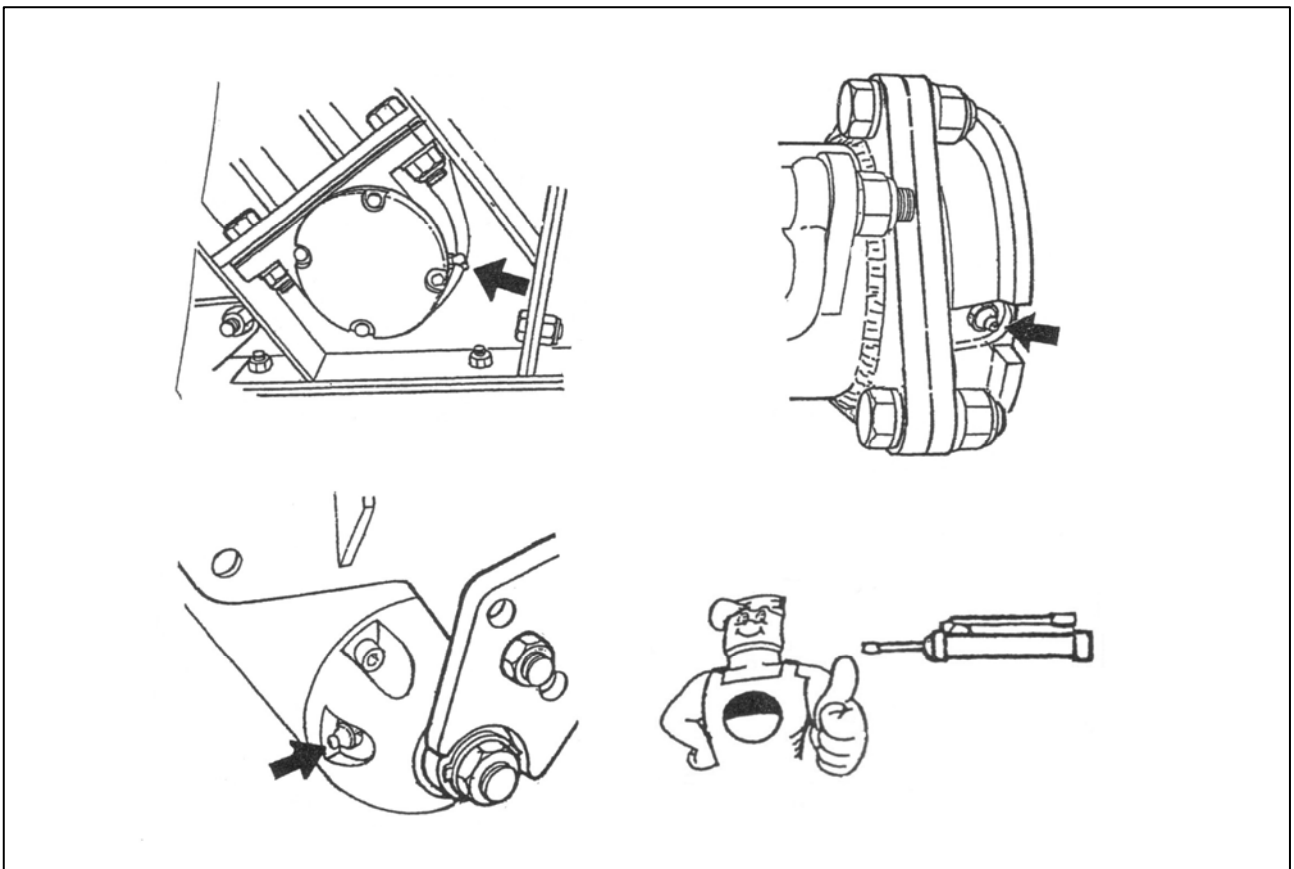



McConnel Generic Parts Manual

Generic parts manuals should be used as a general guide to the components used on the machine; to ensure accurate parts information for a specific machine please refer to the 'Interactive Parts Database' on our website which identifies the exact components used on the machine when it was manufactured based on the machine's unique serial number.

Direct access can be gained using the web address or QR code below.
<http://www.mcconnel.com/support/product-support/interactive-parts-database/>

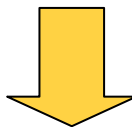

Design improvements may have altered some of the parts listed in this manual; latest parts will always be supplied if they are interchangeable with earlier ones.

MAIN ASSEMBLY

Module:
7361803

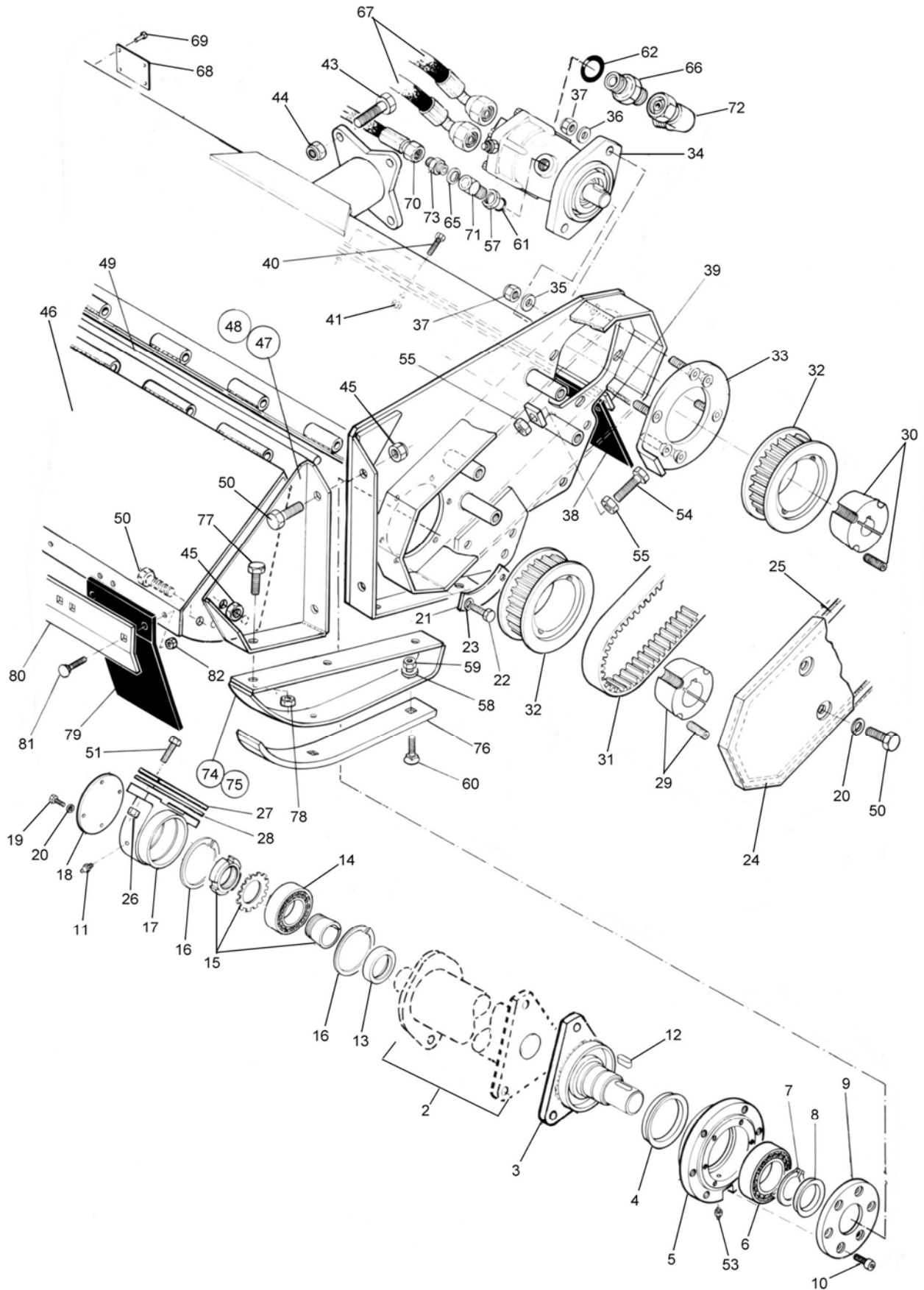



MAIN ASSEMBLY

REF.	QTY.	PART No.	DESCRIPTION
		7361803	1.6m PISTON BELT DRIVE 77HP FLAILHEAD
1	1	7290397	1.6M CASING - L/H Build
		7290410	1.6M CASING - R/H Build
2	1	21176.01	1.6M ROTOR - Tri-Drive (<i>Illustrated</i>)
		22497.21	1.6M ROTOR - Quad Drive
3	1	21220.01	DRIVE HUB - Tri-Drive Rotor Builds
		22269.07	DRIVE HUB - Quad Drive Rotor Builds
4	1	7290048	V-SEAL
5	1	7290321	BEARING HOUSING - DRIVE END
6	1	0600095	BEARING
7	1	0401255	CIRCLIP - EXTERNAL
8	1	7290049	V-SEAL
9	1	7290023	BEARING RETAINER
10	6	934034	CAPSCREW
11	1	0901121	GREASE NIPPLE
12	1	7290017	KEY
13	1	7290013	BEARING SPACER
14	1	0600096	BEARING
15	1	0600097	ADAPTOR SLEEVE
16	2	7290056	CIRCLIP - INTERNAL
17	1	7290322	BEARING HOUSING - FREE END
18	1	7290042	BEARING COVER
19	4	9313033	SETSCREW
20	4	9100203	SPRING WASHER
21	3	7290073	SPECIAL TAB WASHER
22	6	9313045	SETSCREW
23	6	9100205	SPRING WASHER
24	1	7290343	DRIVE COVER
25	1	7290052	SEALING STRIP
26	4	0311106	SETSCREW
27	<i>as req'd</i>	7290425	SHIM - 3mm
28	<i>as req'd</i>	7290424	SHIM - 2mm
29	1	7290016	TAPER LOCK BUSH
30	1	7290045	TAPER LOCK BUSH
31	1	7290046	BELT
32	2	7290047	PULLEY
33	1	43458.01	MOTOR MOUNTING PLATE - L/H Build
		43458.02	MOTOR MOUNTING PLATE - R/H Build
34	1	8301295	PISTON MOTOR - 77HP
		8301322	PISTON MOTOR - 77HP
35	4	7290051	CLAMP WASHER
36	2	9113006	PLAIN NUT
37	6	9143006	CLEVELOK NUT
38	1	7290405	REAR FLAP
39	1	7290406	CLAMP STRIP
40	11	9300166	BUTTON HEAD SOCKET SCREW
41	12	9143005	CLEVELOK NUT

MAIN ASSEMBLY (Continued)

Module:
7361803

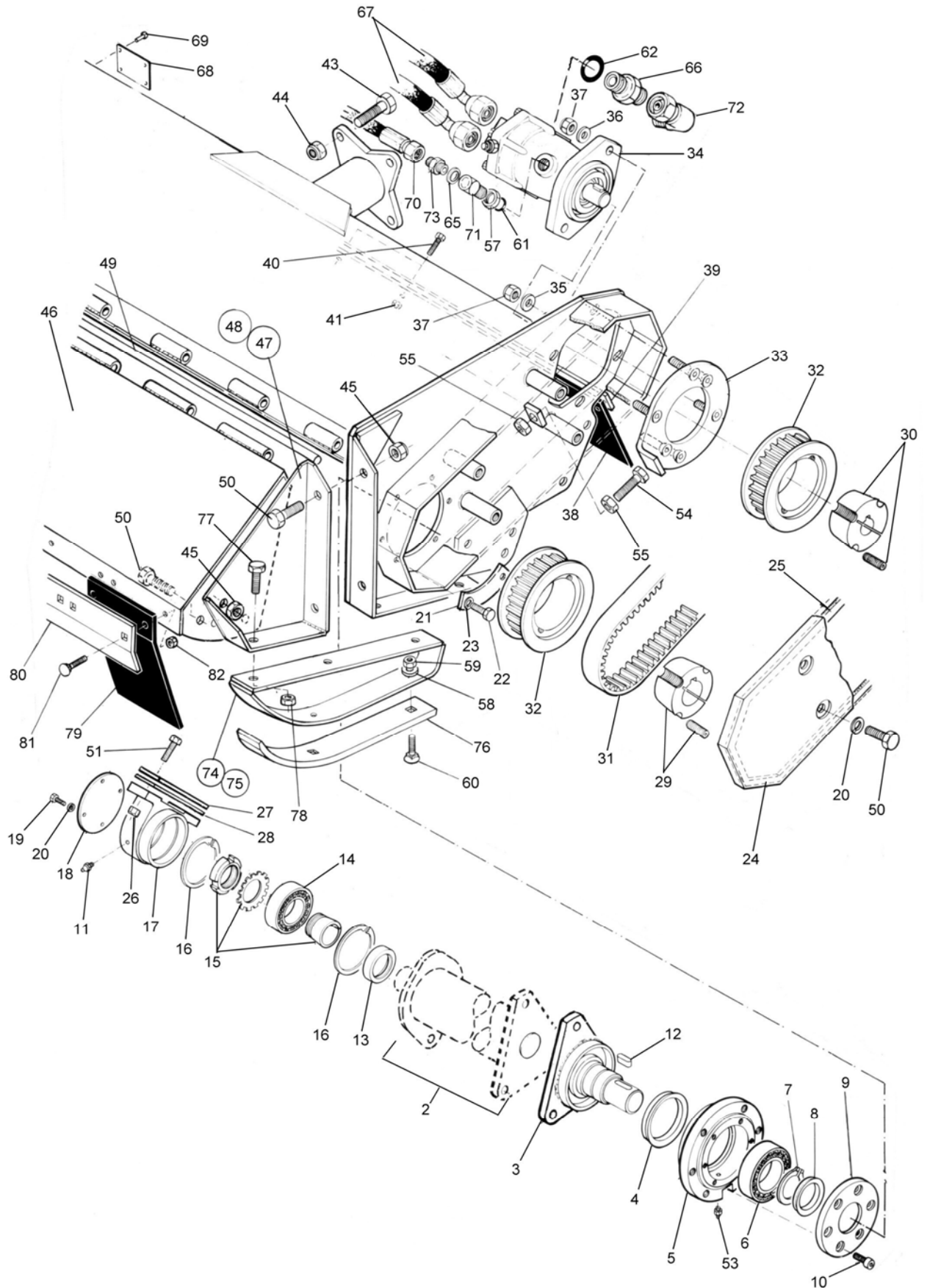



MAIN ASSEMBLY (Continued)

REF.	QTY.	PART No.	DESCRIPTION
42	1	9313055	BOLT
43	4	9200031	BOLT
44	2	9100028	CLEVELOK NUT
45	48	9100024	FLANGED NUT
46	1	7290403	FRONT HOOD
47	1	7290388	HOOD BRACKET - L/H
48	1	7290387	HOOD BRACKET - R/H
49	1	7290065	HOOD PIVOT BAR
50	6	30.073.25	HEX BOLT
51	2	9200023	BOLT
52	2	9200024	BOLT
53	1	0901125	GREASE NIPPLE
54	1	9313117	SETSCREW
55	2	9113007	PLAIN NUT
56	2	9200028	BOLT
57	1	0131007	PLAIN NUT
58	2	0100104	PLAIN WASHER
59	6	0142004	AERO NUT
60	6	2012034	TINE BOLTS
61	1	8600908	O RING
62	2	8600916	O RING
63	1	00999588	HOSE SLEEVING - 900mm
64	1	42241.27	TAPER ROLLER ASSEMBLY
65	1	8650103	BONDED SEAL
66	2	8581256	ADAPTOR
67	2	8501238	HOSE - 1" BSPFS/F135 x 36" LONG
68	1	1335246	SERIAL No. PLATE
69	4	7103230	POP RIVET
70	1	10.007.20	HOSE - 5/8" BSP ST/ST x 1000mm
71	1	42739.01	ADAPTOR ELBOW
72	2	8581212	ELBOW - 90°
73	1	8581175	UNION
		7290034	SKID KIT
74	1	7290390	SKID - L/H
75	1	7290389	SKID - R/H
76	2	7290391	SKID SHOE
77	6	0311105	SETSCREW
78	6	0141005	SELF-LOCKING NUT
		7290411	FRONT FLAP KIT -
79	10	7290066	FLAP
80	1	7290404	FLAP CLAMP STRIP
81	20	9293054	CUP SQUARE BOLT
82	20	9143004	SELF-LOCKING NUT

1.6M TRI-DRIVE ROTOR

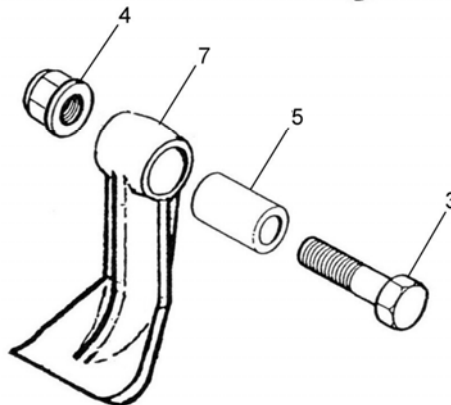
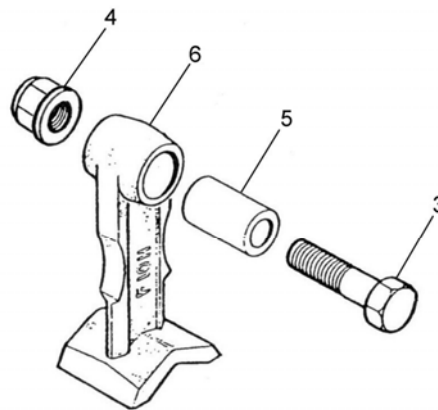
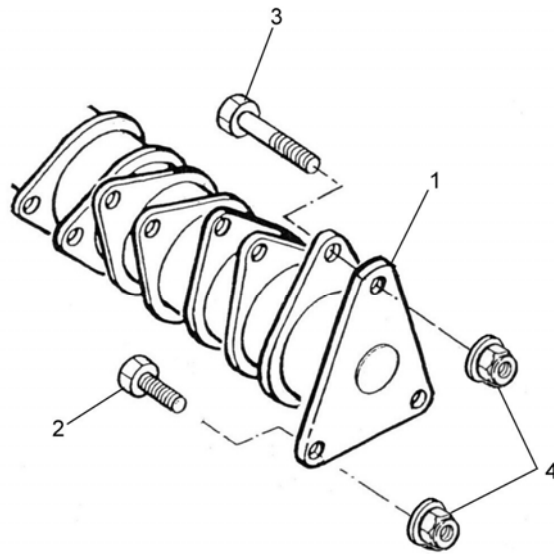
Module:
22497.21



REF.	QTY.	PART No.	DESCRIPTION
ROTOR & FLAILS			
1	1	21176.01	ROTOR - (WRAP AROUND LUGS)
2	1	7390026	FLAIL BOLT
3	31	7390025	FLAIL BOLT
4	34	9100024	FLANGED NYLOK NUT
5	32	7314223	FLAIL PIVOT BUSH
6	32	7314366	F10 DOUBLE EDGED CAST FLAIL
7	32	7390276	F10 SINGLE EDGED CAST FLAIL

1.6M QUAD DRIVE ROTOR

Module:
22497.21

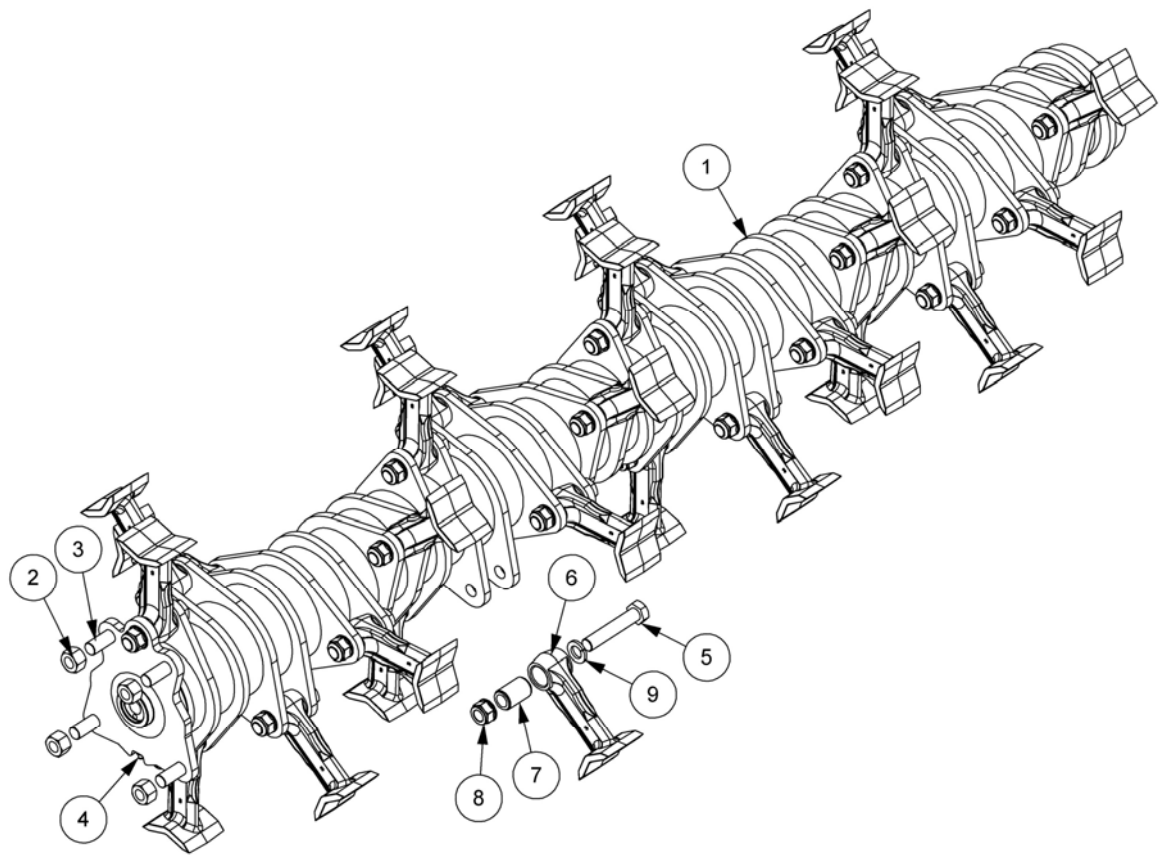
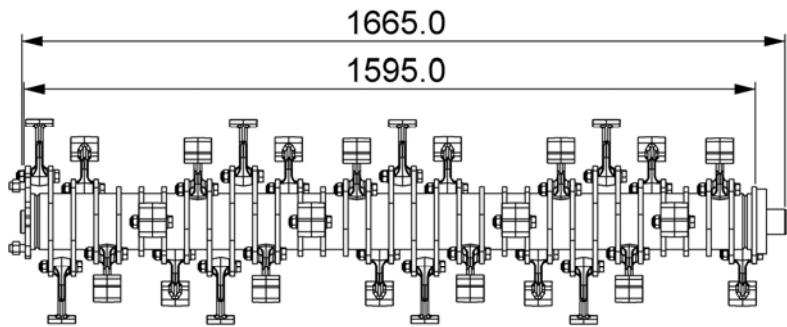
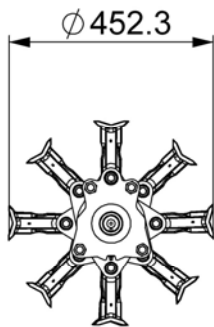

REF.	QTY.	PART No.	DESCRIPTION
		22497.21	1.6M ROTOR c/w F10DE CAST FLAILS
1	1	22269.06	1.6M QUAD ROTOR - WRAP ROUND
2	4	9143007	SELF-LOCKING NUT
3	4	9353097	CAPSCREW
4	1	0901161	GREASE NIPPLE
5	32	7390025	SPECIAL BOLT
6	32	7314366D	F10H FLAIL (CAST)
7	32	7314223	FLAIL PMOT BUSH
8	32	9100024	SELF-LOCKING FLANGE NUT
9	32	9100207	SPRING WASHER

DRIVE MODULE

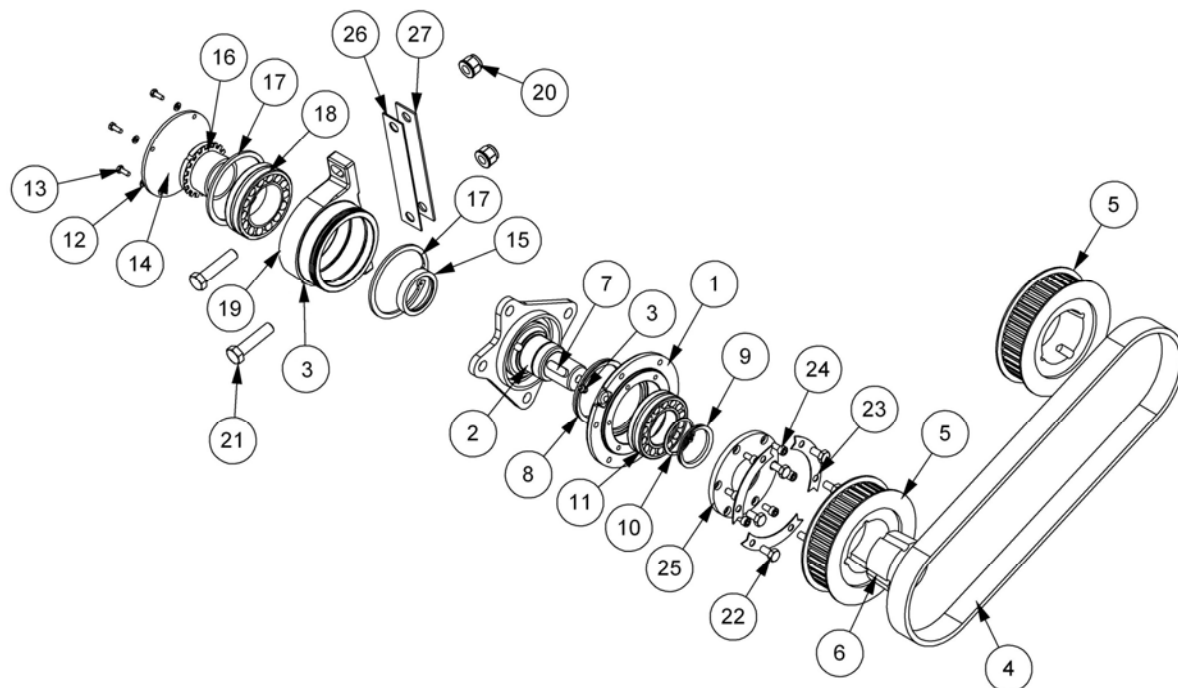

REF.	QTY.	PART No.	DESCRIPTION
BELT DRIVE MODULE (QUAD DRIVE)			
1	1	7290321	BEARING HOUSING (DRIVE END)
2	1	22269.07	DRIVE HUB
3	2	0901121	GREASE NIPPLE
4	1	7290046	BELT
5	2	7290047	BELT SPROCKET
6	1	7290016	TAPER LOCK BUSH
7	1	7290017	KEY
8	1	7290048	V SEAL
9	1	7290049	V SEAL
10	1	0401255	EXTERNAL CIRCLIP
11	1	0600095	SPHERICAL ROLLER BEARING
12	4	9100203	SPRING WASHER
13	4	9313033	SETSCREW
14	1	7290042	BEARING COVER
15	1	7290013	BEARING SPACER
16	1	0600097	ADAPTOR SLEEVE
17	2	7290056	INTERNAL CIRCLIP
18	1	0600096	SPHERICAL ROLLER BEARING
19	1	7290322	BEARING HOUSING
20	2	9100024	SELF-LOCKING FLANGE NUT
21	2	9200023	BOLT
22	6	9313045	SETSCREW
23	3	7290073	SPECIAL TAB WASHER
24	6	9343034	CAPSCREW
25	1	7290023	BEARING RETAINER
26	1	7290424	SHIM - 2mm
27	1	7290425	SHIM - 3mm



This page is intentionally blank

1.6M ROLLER ASSEMBLY

Module:
42241.27

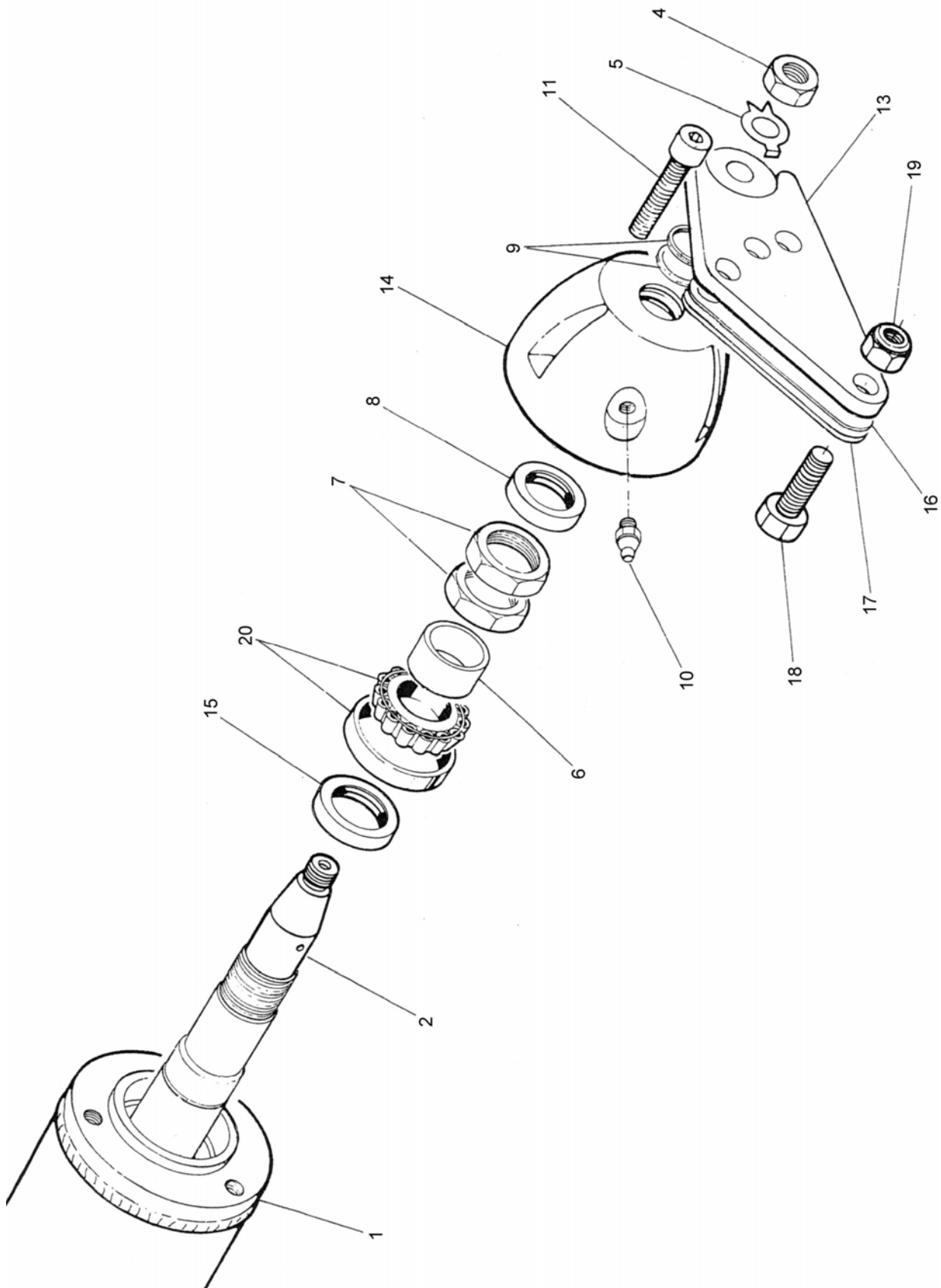

**1.6M ROLLER ASSEMBLY**

REF.	QTY.	PART No.	DESCRIPTION
		42241.27	ROLLER ASSEMBLY
1	1	42241.02	ROLLER
2	1	42242.02	AXLE
3	1	9113008	PLAIN NUT - R/H (<i>not illustrated</i>)
4	1	9100026	PLAIN NUT - L/H
5	2	7190023	TAB WASHER
6	2	42245.01	SPACER
7	4	42244.01	LOCKNUT
8	2	8629125	SEAL
9	4	0412120	SPIROLOX RING
10	2	0901121	GREASER - STRAIGHT
11	6	9343075	CAPSCREW
12	1	42246.02	ROLLER BRACKET - R/H (<i>not illustrated</i>)
13	1	42246.01	ROLLER BRACKET - L/H
14	2	42243.01	END CAP
15	2	8629213	SEAL
16	<i>as req'd</i>	42257.01	SHIM - 1.2mm
17	<i>as req'd</i>	42257.02	SHIM - 2.0mm
18	4	9313097	SETSCREW
19	4	9143007	SELF-LOCKING NUT
20	2	0600105	TAPER ROLLER BEARING

1.6M ROLLER ASSEMBLY

Module:
21523.04

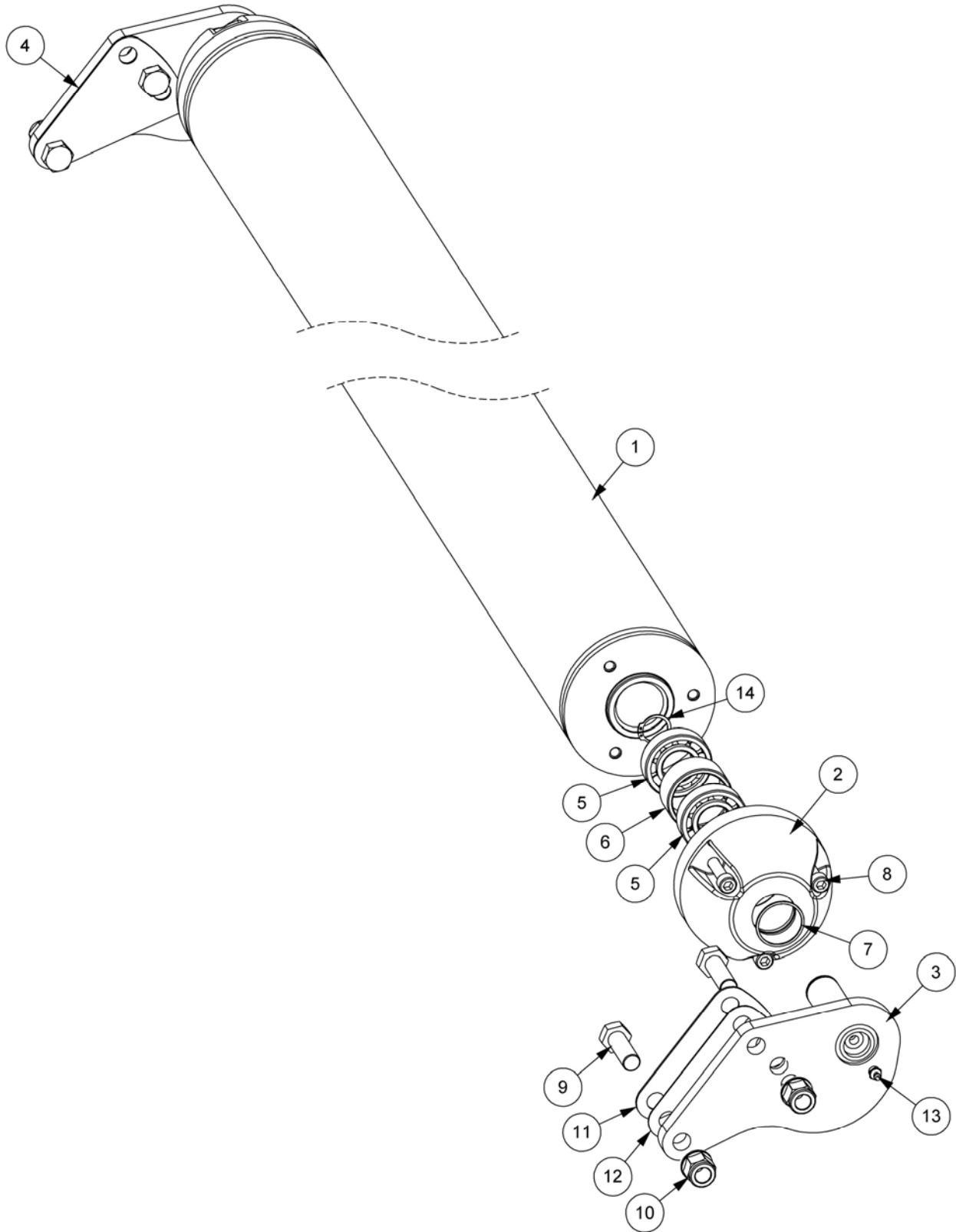



1.6M ROLLER ASSEMBLY

REF.	QTY.	PART No.	DESCRIPTION
		21523.04	1.6M ROLLER ASSEMBLY
1	1	21394.26	1.6M ROLLER
2	2	21394.32	ROLLER END CAP
3	1	21524.09	ROLLER BRACKET - L/H
4	1	21524.10	ROLLER BRACKET - R/H
5	4	0600111	BALL BEARING
6	2	21523.31	BEARING SPACER
7	2	0402240	INTERNAL SPIROLOX RING
8	6	9343105	CAPSCREW
9	4	9200025	BOLT
10	4	9100024	SELF-LOCKING FLANGE NUT
11	<i>as req'd</i>	42257.02	ROLLER SHIM - 2.0mm
12	<i>as req'd</i>	42257.01	ROLLER SHIM - 1.2mm
13	2	0901121	GREASE NIPPLE
14	2	0401225	EXTERNAL CIRCLIP

DECALS

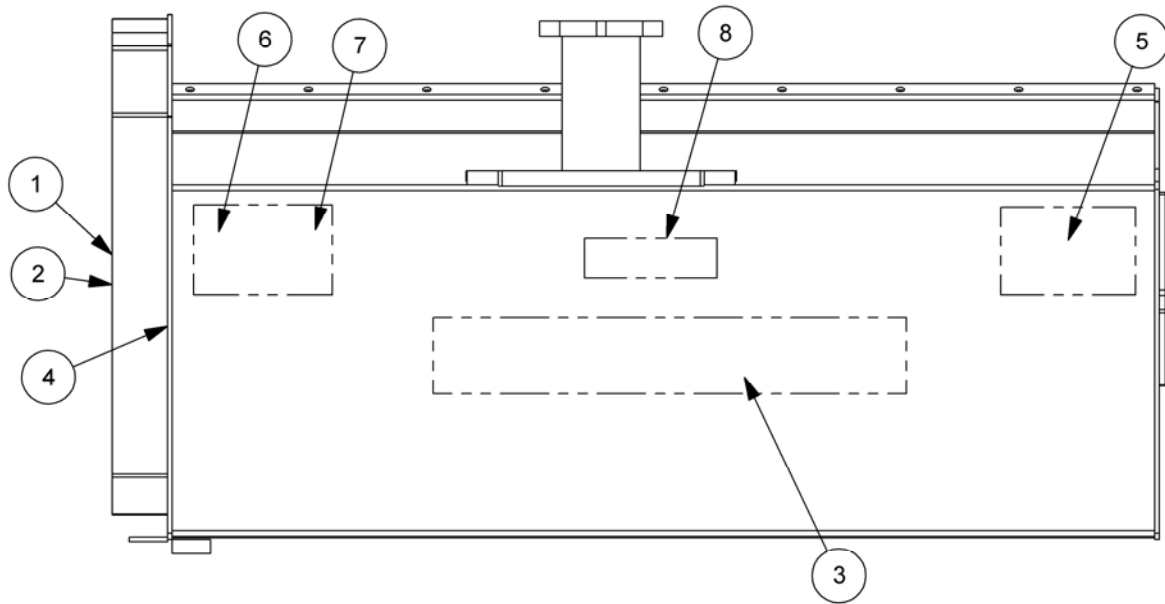

REF.	QTY.	PART No.	DESCRIPTION
DECALS			
1	1	1290478	DECAL - BELT ALIGNMENT
2	1	1290065	DECAL - TOOTH BELT
3	1	1290527	DECAL - McCONNEL
4	1	1290392	DECAL - PARTS
5	1	1290462	DECAL - INSTRUCTION
6	1	1290341	DECAL - WARNING
7	1	09.810.01	DECAL - GREASE (8hrs)
8	1	1290502	DECAL - 77HP

FLAILS

F10 D.E. Cast Flail
(Part No. 7314366D)

HEDGE



FIXINGS

- ← Bolt: 7314201 →
- ← Bush: 7314223 →
- ← Washer: 0100206 →
- ← Locknut: 0141006 →

F10 D.E. Forged Flail
(Part No. 41391.02)

HEDGE

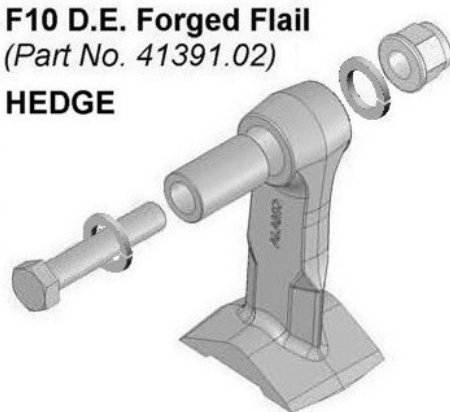

F10 S.E. Cast Flail
(Part No. 7390276)

HEDGE

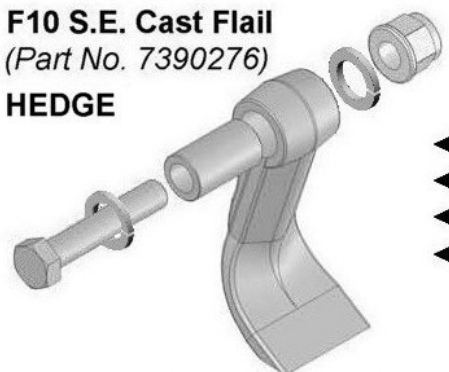

FIXINGS

- ← Bolt: 7314201 →
- ← Bush: 7314223 →
- ← Washer: 0100206 →
- ← Locknut: 0141006 →

F16 D.E. Cast Flail
(Part No. 21904.02)

HEDGE



D.E. Omega Flail
(Part No. T1840572)

HEDGE



Omega Rotor use only

FIXINGS

- ← Bolt: 7390006 →
- ← Bolt: 7314201 →
- ← Bush: 21215.02 →
- ← Bush: 7314223 →
- ← Washer: 0100206 →
- ← Locknut: 0141006 →

F14 D.E. Cast Flail
(Part No. 21904.05)

HEDGE



F10 Grass Flail
(Part No. 7190315)

GRASS

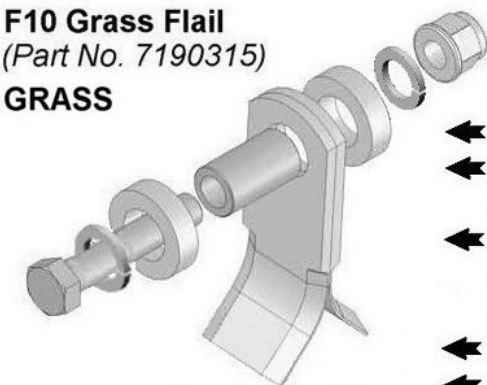

FIXINGS

- ← Bolt: 7314201 →
- ← Bush: 21215.02 →
- ← Bush: 7314223 →
- ← Spacer: 7190010 →
- ← Spacer: 7190172 →
- ← Shackle: 7190175 →
- ← Washer: 0100206 →
- ← Locknut: 0141006 →

Forged Boot Flail
(Part No. 7190462)

UNIVERSAL

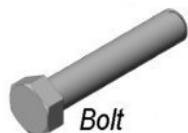
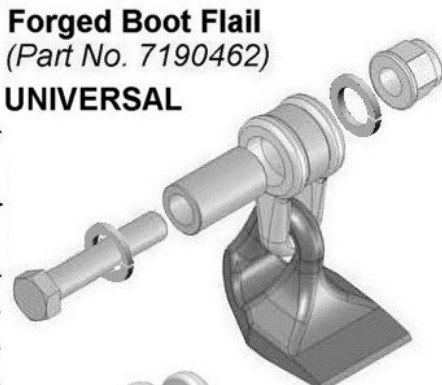



McConnel Limited, Temeside Works, Ludlow, Shropshire SY8 1JL. England.
Telephone: 01584 873131. Facsimile: 01584 876463. www.mcconnel.com