

Publication 134

Serial No.

Part No.

71-92-855

PA921

Operation & Spares manual

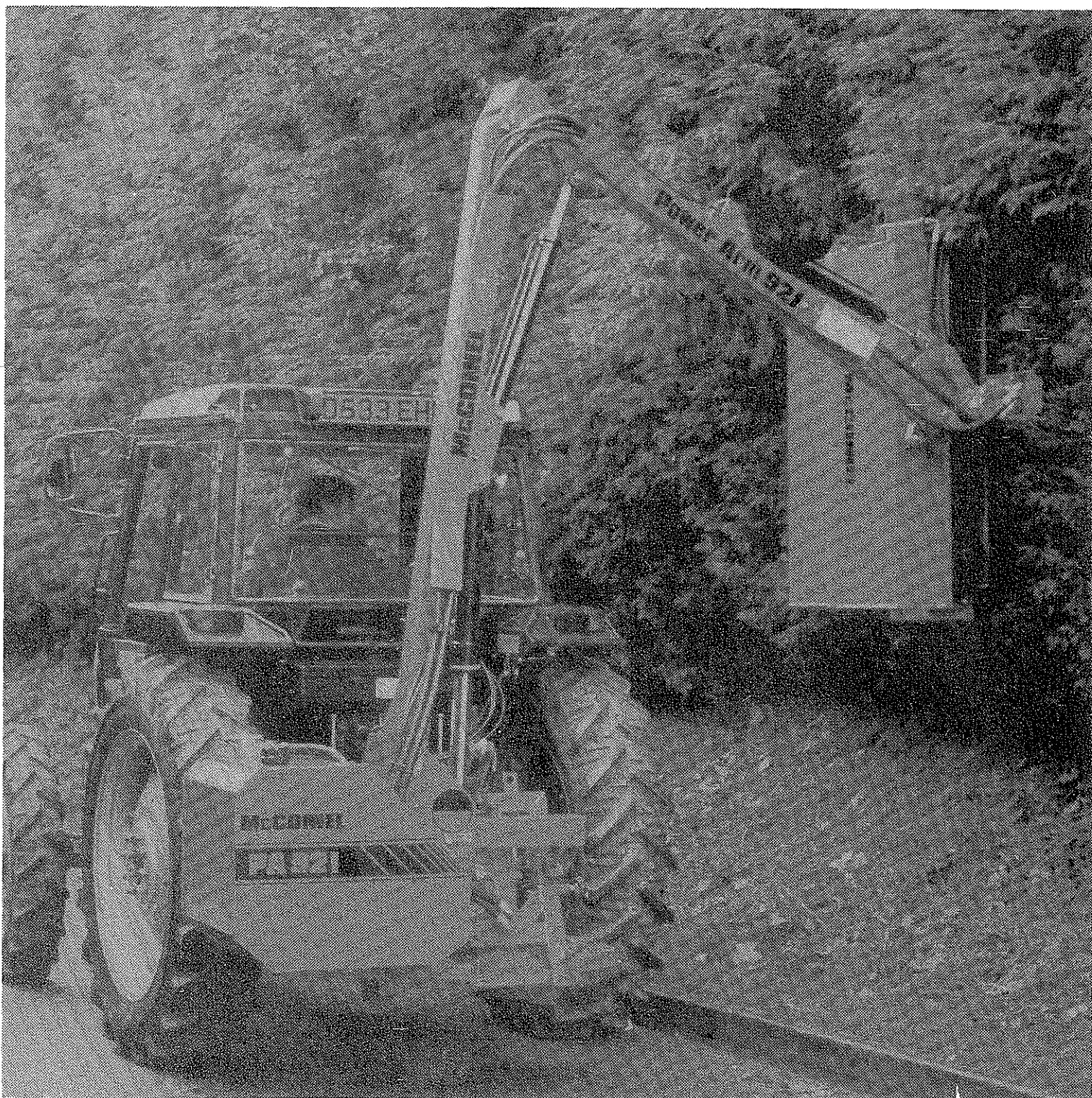

READ THE BOOK FIRST

It might save hours and pounds later

**When ordering spare parts always
quote the machine type and serial
number as well as the part number**

**Factory re-built service exchange
units of the major hydraulic components
are available from your dealer**

List of contents

GENERAL INFORMATION	Page 1
SAFETY PRECAUTIONS	Page 2
INTRODUCTION	Page 3
FITTING	Page 4
TRACTOR SELECTION	Page 4
Linkage requirements	" 4
Linkage isolation	" 4
Check chains/stabilisers	" 4
Tractor relief valve	" 4
Tractor hydraulic flow rates	" 4
PTO shaft	" 4
Draft control	" 4
TRACTOR PREPARATION	Page 5
Ballast weight	" 5
Fitting operator guard	" 5
John Deere	Page 6
DELIVERY	Page 7
ATTACHMENT TO TRACTOR	" 7
FITTING CONTROL UNIT IN CAB	Page 10
OIL REQUIREMENTS	Page 11
RUNNING UP PROCEDURE	Page 12
REMOVAL FROM TRACTOR	Page 13
STORAGE	" 13
OPERATION	Page 14
LIMITATION	Page 14
HIGHWAY WORKING	" 14
OPERATOR GUARD	" 14
PREPARATION	" 14
MACHINE CONTROLS	Page 15
BREAKAWAY	" 15
TRANSPORT POSITION	" 15
MOVING FROM TRANSPORT TO WORK	" 15
ENGAGING DRIVE	Page 16
FORWARD SPEED	" 16
TRACTOR POSITION	" 16
OPERATING SPEED	" 16
WORKING PRACTISES	" 16
OVERHEAD OBSTRUCTIONS	Page 17
WIRE TRAP	" 17
HEDGE CUTTING PROCEDURE	Page 18
Preliminary precautions	" 18
Upward cutting	" 18
Roller	" 18
Downward cutting	Page 19
Reversing rotation	" 19
Hedge shape	" 19
Cutting sequence	Page 20
GRASS CUTTING	Page 21
REAR FLAP (optional extra)	" 21
LIFT FLOAT KIT (optional extra)	Page 22

MAINTENANCE

Page 23

LUBRICATION	Page 23
General	" 23
P.T.O. shaft	" 23
HYDRAULIC SYSTEM	Page 24
ROTOR VALVE	" 24
FLOAT KIT ACCUMULATOR TEST (if fitted)	" 24
CABLE CONTROL VALVE	Page 25
Replacing spool 'O' rings	" 25
Relief valve	Page 26
Non return valve	" 26
CABLES	" 26
HYDRAULIC PUMPS	Page 27
HYDRAULIC MOTOR	" 27
HYDRAULIC RAMS	Page 28
HYDRAULIC HOSES	Page 29
P.T.O. GEARBOX	" 30
FLAIL HEAD	" 30
HOSE CONNECTIONS	Page 31

SPARE PARTS

Page 32

MAIN FRAME ETC	Page 33
MAIN ARM	Page 35
DIPPER AND ANGLING MECHANISM	Page 37
HEDGE FLAIL HEAD	Page 39
GRASS FLAIL HEAD	Page 43
HYDRAULIC INSTALLATION	Page 45
CONTROL VALVE	Page 47
CONTROL UNIT AND CABLES (PA93 only)	Page 49
GEARBOX/PUMP/ROTOR VALVE (PA92 Si only)	Page 51
GEARBOX/PUMP/ROTOR VALVE (PA92 Ti only)	Page 53
ROTOR VALVE (PA92 Ti only)	Page 53
GEARBOX	Page 57
HYDRAULIC TANK	Page 59
CONTROL MOUNTING ASSEMBLY	Page 61
LIFT RAM	Page 62
REACH RAM	Page 63
ANGLING RAM	Page 64
LIFT FLOAT KIT	Page 65
CAB GUARD KIT	Page 66

GENERAL INFORMATION

Read this manual before fitting or operating the machine. Whenever any doubt exists contact your dealer or the McConnel Service Department for assistance.

Use only McConnel spare parts on McConnel equipment and machines. This manual includes an illustrated spare parts breakdown and the interpretation which precedes it should be read before ordering replacement components.

DEFINITIONS

The following definitions apply throughout this manual:

WARNING

An operating procedure, technique etc., which can result in personal injury or loss of life if not observed carefully.

CAUTION

An operating procedure, technique etc., which can result in the damage of either machine or equipment if not observed carefully.

NOTE

An operating procedure, technique etc., which is considered essential to emphasise.

Left and Right-Hand

This term is applicable to the machine when fitted to the tractor and viewed from the rear. This also applies to tractor references.

Record the serial number of your machine on this page and always quote this number when ordering spares. Whenever information concerning the machine is requested remember to also state the type of tractor to which it is fitted.

MACHINE SERIAL NUMBER	INSTALLATION DATE
MODEL DETAILS	
DEALERS NAME	
DEALERS TELEPHONE NUMBER	

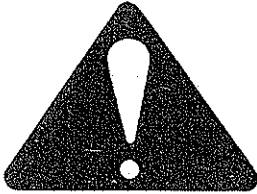

WARNING

NEVER

- ... permit inexperienced personnel to operate the machine without supervision.
- ... stand under the raised flail head.
- ... cut over the far side of a hedge with the flail cutting towards the operator.
- ... continue to operate the flail when wire has wrapped around the rotor.
- ... leave the tractor seat with the flail still rotating.
- ... operate the flail without the correct hood properly fitted in position.
- ... exceed 540 rpm on the p.t.o. shaft.
- ... stop the engine with the p.t.o. engaged.
- ... operate the machine without a cab safety guard
- ... operate the machine without the p.t.o. shaft guard in position.

ALWAYS

- ... inspect the work area or hedgerow for wire, steel posts, large stones, bottle and other dangerous materials and remove them before starting work.
- ... ensure bystanders are kept away from the machine during all flailing operations.
- ... check frequently, nuts and bolts for tightness and also check roll pins, shackles and flails for security.
- ... replace missing or damaged flails as soon as possible to avoid vibration and damage to the machine.
- ... disengage the p.t.o. and stop the tractor engine before making any adjustments.
- ... Take extra care when working close to or manoeuvring around overhead obstructions especially power lines.

CAUTION

One of the features of the Power Arms 921Si and Ti is the ability to cut close to the tractor in confined spaces. This means that in some instances the flail head casing can be made to foul the tractor if reasonable care is not observed.

INTRODUCTION

The Power Arm 921 is a hydraulically driven hedge and grass trimmer designed to fit on the three point linkages of the great majority of tractors without having to use extra brackets or fittings.

All Power for the operation of the rotor is provided by a high performance pump unit that is operated from the tractors P.T.O. shaft. The machine carries its own 25 gallon (117 litre) oil reservoir which incorporates an oil strainer and a 10 micron return flow filter.

The Power Arm 921 can be supplied either fully independent or with the arms operated by tractor supply. The fully independent model which is fitted with a tandem pump should be specified where any doubt exists on the hydraulic oil supply from the tractor. The economy version which utilises the tractors hydraulic oil supply to provide movement of the arms is fitted with a single pump for the operation of the rotor.

The models also differ in that engagement of the rotor drive on the tractor supply model is effected by operation of the tractors P.T.O. lever, while on the fully independent version a rotor control valve is operated by an extra lever on the control console within the cab.

The machine has been designed to cut on the right hand side of the tractor only and in addition flail rotation can be altered for an upward or downward cutting action.

The flail head is despatched with the flails to cut in an upward motion and is equipped with an adjustable hood to minimise flying debris. An additional hood for the rear of the flail head is available should the rotation of the flails be reversed and the operator is further protected by the mesh guard which attaches to the tractor.

The controls are cable operated from within the tractor cab and the levers can be mounted in a number of different positions to suit the operator.

The machine is equipped with automatic self resetting gravity breakaway system which allows the flail head to pivot up and back. On resetting a rubber damper absorbs any shock loads. The breakaway geometry also allows the complete flail to be folded compactly for travel on the highway.

An in built stand is supplied to aid stability when the machine is unhitched from the tractor.

FITTING

TRACTOR SELECTION

Linkage requirements

The power arm 921 will fit almost any tractor with a category "II linkage.

Linkage isolation

Although it may be possible to operate the semi independent version of the PA 921 without linkage isolation a severe strain would be put upon the attachment yoke and pins. Most modern tractors are equipped with a ready means of providing linkage isolation through a conveniently operated valve.

Linkage isolation is not required on the fully independent model of the PA 921 or and the tractors hydraulic controls should be neutralised.

Check chains/stabilisers

To hold the machine firmly in position, check chains or stabiliser bars must be fitted. It is dangerous to operate the machine without.

Tractor relief valve

The main relief valve in the hedger hydraulic control unit is set at 2000 PSI (140 Bar). Therefore if operating the PA 921 in semi independent form the tractors relief valve setting must be at least a little above this figure for satisfactory operation.

Tractor hydraulic flow rates

Oil flow rates are not crucial when operating a semi independent PA 921. Flow rates of up to 10 gpm (45 l/min) should not have any adverse affect to the inching response that is sometimes required from the control valve.

P.T.O. shaft

Tractor must be equipped with live drive independent PTO shaft to enable forward movement to be halted while the flail head continues to operate.

Draft control

Loads imposed through the draft sensing mechanism will not normally be sufficient to put a strain on the tractor, however any provision for draft control should be set to minimum response. Where a draft control rocker is fitted with a dead pin position this should be utilized.

TRACTOR PREPARATION

Ballast weight

Irrespective of the size of tractor it must be stable whilst operating the hedge cutters under all conditions. Due regard must be paid to operating on slopes and front end ballast as well as rear wheel weights to counterbalance the overhang of the flail head should be added as appropriate. On steeply banked ground it may not be sufficient to depend alone on the counterweight afforded by the oil reservoir.

In addition rear wheel track should be set as wide as possible to increase stability. It will also increase the protection to the reservoir.

Fitting operator guard

A tractor fitted with a cab that has safety glass windows should be used whenever possible. This is a basic safety precaution applicable to the use of all flail-type hedge trimmers.

Power arms are supplied with an operator guard kit part number 73 13 324 which must be fitted to the tractor before commencing work.

It consists of two areas of wire mesh which can be shaped to suit and secured against the cab window with spring loaded hooks, the upper edge being anchored around the cab gutter and the lower edge around the mudwing.

Owing to the great range of cabs it may be necessary to adapt or make brackets to secure the mesh.

Where the flail is operated on a tractor that is equipped with a safety frame or roll bar only, then an additional frame must be made and fixed to the tractor on to which the guard mesh can be secured. In addition to the guard mesh, a sheet of Polycarbonate transparent glazing must be fitted to the frame to provide further operator protection. This material must also be used when the cab does not have safety glass installed.

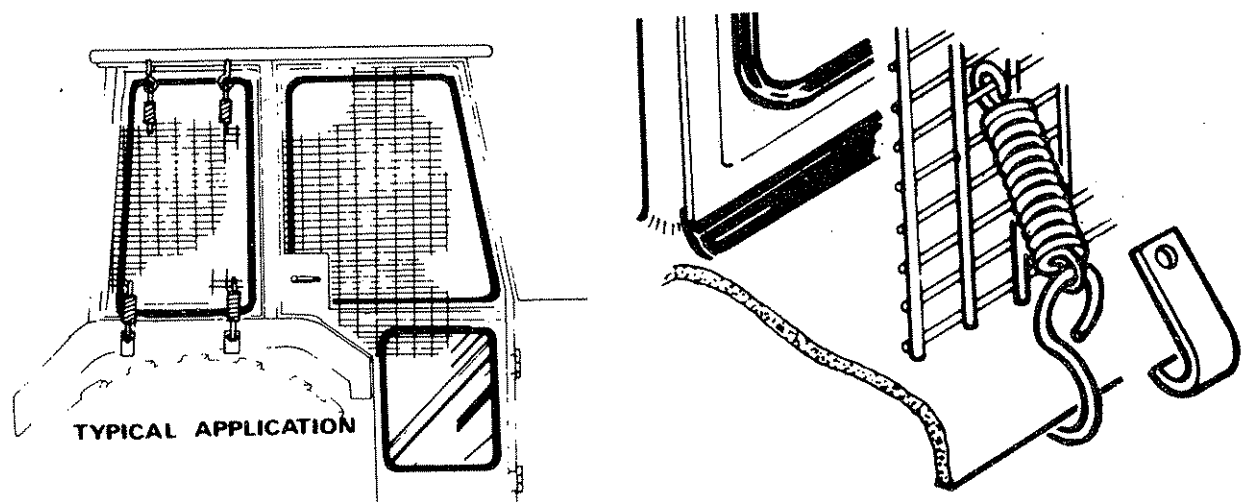

Polycarbonate transparent sheeting is an impact resistant material which can be readily sawn and shaped to requirements. Unfortunately it is susceptible to surface damage and scratching, therefore it is advisable to place the material on the inside of the window for protection. No attempt should be made to wipe the sheeting with dirt engrained cloth.

Toughened grades of polycarbonate sheeting are available under the brand names of "Makrolon", "Tuffak", and "Lexan".

In case of difficulty in obtaining this material locally, contact F.W. McConnel Ltd through your normal dealer.

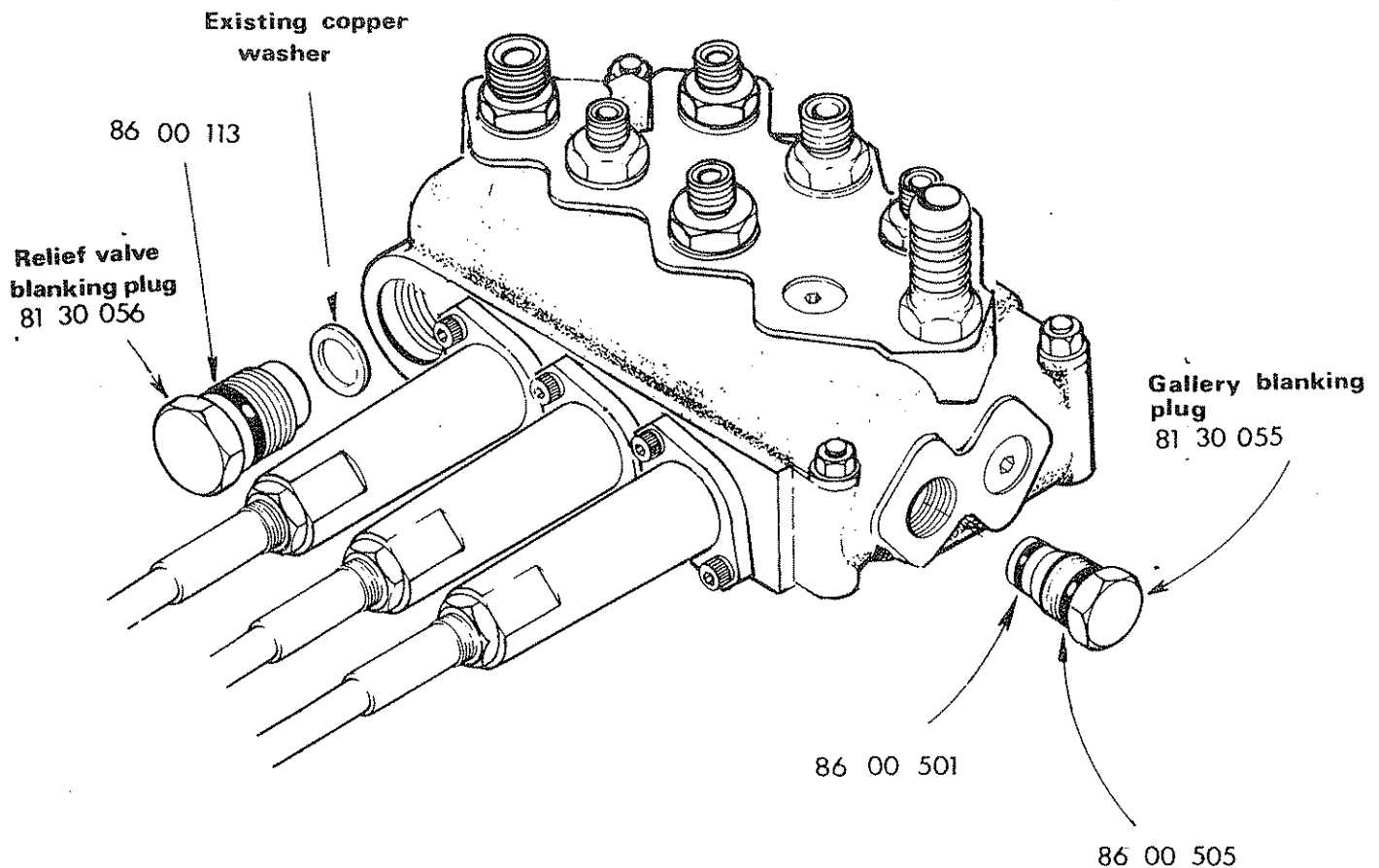

JOHN DEERE CONVERSION KIT 81 30 059

John Deere

The John Deere utilises a 'closed centre' hydraulic principle and because of this it is recommended to use hedgecutters with a fully independent hydraulic system on tractors of this manufacture. However it is practicable for the semi independent model of the PA 93 to be used with these tractors subject to certain modifications. There are the following two alternatives

1. A flow limiting valve manufactured by John Deere is available to provide an 'open centre' external supply sufficient for PA 93 requirements. For further advice consult your John Deere dealer.
2. Components are available from F.W. McConnel Ltd, to convert the standard 'open centre' valve. Part No. 81-30-059 consists of a relief valve blanking plug which should be installed in place of the existing relief valve. Take care when extracting the relief valve not to damage the copper sealing washer as it is reused with the blanking plug. In addition a pressure gallery blanking plug is installed in place of the standard blanking plug at the valve outlet end on the cable side of the block .

When working in this mode the tractor's pressure control valve must not exceed 2500 P.S.I. (170 Bar).

DELIVERY

The machine is delivered in a partially dismantled condition. To make ready for attachment to the tractor it will be necessary to:-

Select a hard level surface.

- * Cut the banding straps and fit the hydraulic tank over the leg housing. Secure in position with the leg pin and stabiliser tank strap.
- * Connect suction and return hoses. If two hose clips are used at each end, ensure that their worm drive barrels are opposed at 180°, this will reduce the possibility of air entering the system.
- * Bolt the control valve in position on the rearmost tank carrying plate with the valve projecting to the rear and the connections uppermost.
- * Fill the reservoir to capacity with oil selected from the chart on page 11 to increase the stability of the machine.
- * Remove and discard the transport strap connecting the flail head to the frame.

ATTACHMENT TO TRACTOR

- * On Si model reverse the tractor up as closely as possible and connect the return and supply hoses to the tractor. Fit suitable return connection to the tractor and connect the return hose before connecting the supply hose to the tractor's external services point with a suitable self seal coupling.
- * With the aid of a crowbar prise the flail head sideways until there is sufficient clearance to allow the tractor to be reversed up and the draft links connected. Assistance will be needed to simultaneously select "Reach out" and "angle down" to allow the oil to flow whilst the arms are being moved.

WARNING

As a safety precaution to prevent the possibility of the flail head slipping sideways and the arm collapsing on the fitter as he is prying the head sideways a loop of strong rope or wire, with sufficient slack to allow the required flail head movement should connect the frame and dipper. This will then act as an arrestor in the event of this happening. Leave in position until attachment is complete.

Adjust tractor drop arms to enable the draft links to lower within 15 ins (375mm) of the ground.

Remove the top link and machine yoke completely.

Reverse the tractor squarely to the front of the machine, engage draft link pins and secure.

Attach yoke to the top hitch position on the tractor ensuring the lug for the top link is uppermost.

Unlimber the machine controls from its storage position and fit into the tractor cab. see page 10 .

Install the top link between yoke and upper hitch position on the machine. If necessary fitting Cat. 1 sleeves into the ball ends of the top link.

*Raise the machine on its three point linkage to the working height i.e. when the PTO shaft and the gearbox stub shaft are as near as possible in a straight line.

WARNING
Do not operate quadrant lever or machine controls through the rear cab window whilst standing on or amongst linkage components. Always seek assistance.

*Measure the P.T.O. drive shaft length as shown in the diagram below and subtract 1 inch (25mm).

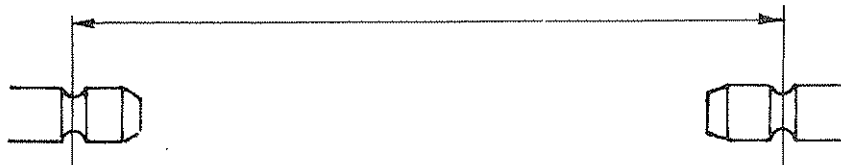

*This measurement which is the fully closed final length of the PTO drive shaft measured button to button should be taken carefully before the PTO drive shaft is shortened to suit by cutting off both the driving and driven members of the tube by an equal amount. Likewise the plastic shield will similarly have to be cut. Take heed that if too much is cut off it cannot be stuck back on. Measure twice and cut once. Accurate measurement is important on some close coupled tractors to ensure maximum engagement during operation.

Lower the machine to the ground and fit the P.T.O. shaft in position. Ensure that the collar locking devices on the P.T.O. shaft are fully engaged and wrap the torque chain around the tractor drawbar or any convenient point to prevent the shaft guard from rotating.

Raise the machine to the working height

Check that the rotor control valve is in the stop position (Ti model only).
Unscrew the white tap on the lift ram.

With P.T.O. engaged on Ti model or with tractor external services activated on Si model (see page 12) select "Lift down" this will level the frame and enable the lower yoke pins to be fitted. Select the hole which will, as near as possible position the P.T.O. shaft horizontally in line.

Lower the quadrant lever so that the machines weight is taken by the yoke.

Adjust the top link to bring the pillar upright.

* Remove the rope arrestor loop.

Carry out final adjustment of the tractor lift arm levelling box to bring the main frame horizontal. This should be checked with the arms at approximately half reach with the flail head clear of the ground.

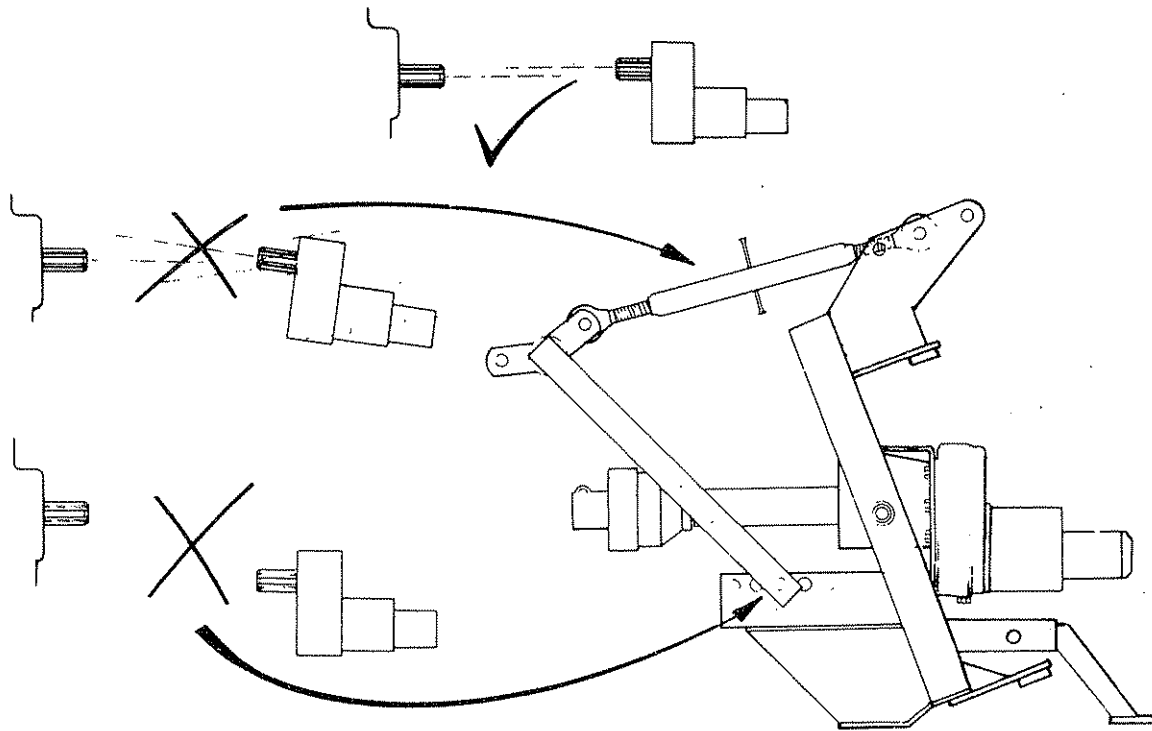

Tighten up the check chains or adjustable stabilisers to hold the machine rigid with out side-sway.

Remove the parking feet, turn inward 90° and re-locate in their housings.

Carefully operate the machine through its full range of movement whilst checking that the hoses are not strained, pinched, chaffed or kinked and that all movements are functioning correctly.

*Assemble the cover plate and the hedge hood into position

Fold the machine into the transport position (see page 15)

The machine is now ready to procede to the work site

This procedure is for initial attachment only, for subsequent attachment paras marked * do not apply.

FITTING CONTROL UNIT IN CAB

The 3 lever control unit which is cable operated is mounted on an adjustable stalk that is attached to a seat bracket which is of universal design for mounting in many models of tractor. The bracket is normally trapped between the seat runners and their mounting base. It may sometimes be necessary to drill extra holes in the seat bracket to find the ideal operator position.

On tractors other than quiet cab models it is permissible to attach the control unit to the mudwing or the cladding of the cab observing the precaution that no structural member of the safety frame should be drilled. For this purpose the mounting stalk can be bent round in a 'U' shape.

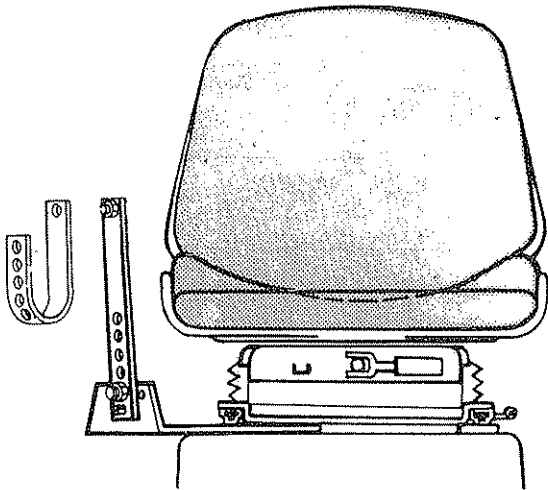
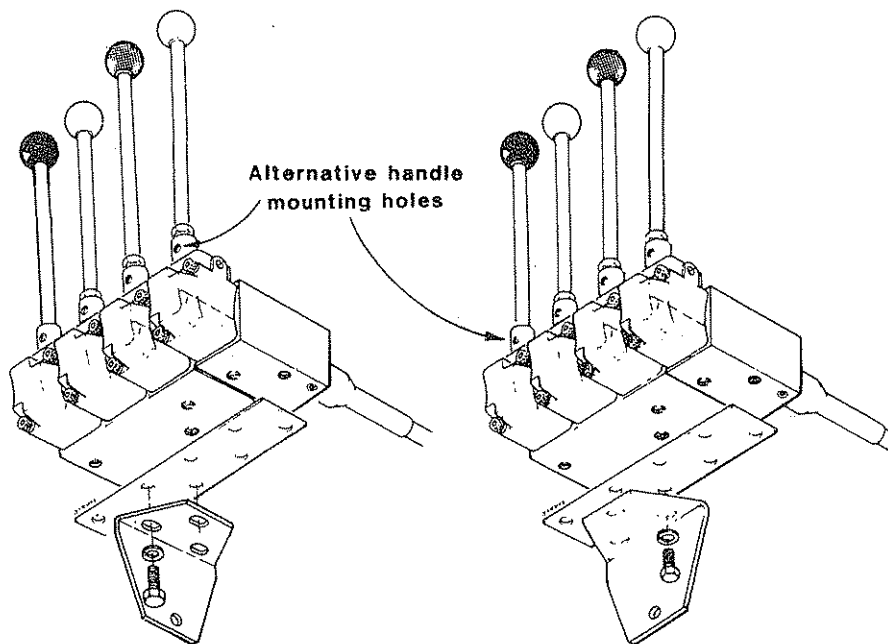

Illustration shows control unit arrangement for fully independent model with extra control handle for rotor ON - OFF. This handle can be mounted either end of the main control block to suit individual operator requirements



The control unit itself is bolted to an angled mounting bracket in either a transverse or longitudinal position thus giving a variety of mounting positions, which in conjunction with the flexibility of the mounting pillar will enable a satisfactory working position to be achieved.

Shown above is detail of alternative fitting of the mounting spigot. In deciding the final position of the control box remember that tight bends in the cables will reduce their operational life. Do not exceed the minimum acceptable bend radii of 8"

The handles may be screwed into alternative holes in the levers to give an 'in line' installation should it be desirable.

OIL REQUIREMENTS

Tank

The machine is delivered from the factory without oil. Fill the reservoir with a light hydraulic oil as recommended in the chart until the oil level is approximately 2" below the top of the tank. The total capacity is approximately 117 litres (25 galls)

Do not overfill.

Supplier	Cold or temperate climate	Hot climate
Castrol	Agricastrol hydraulic oil Hy-spin AWS32	Hy-spin AWS68
Shell	Tellus 27	Tellus 33
Mobil	D.T.E.25	D.T.E.26
Esso	Nuto 'H' or 'A' 32	Nuto 'H' or 'A' 68
Texaco	Rando HD 32	Rando HD 68
Gulf	Hydrasil 32	Hydrasil 68
B.P.	Energol HLP 32	Energol HLP 68
Dalton	Silkolene Dove 32 or Derwent 32	Silkolene Dove 68 or Derwent 68
Elf	Hydrelf 32	Hydrelf 68

Gearbox

Check the gearbox oil level. On level ground gearbox should be fitted until oil dribbles out of the level plug. Top up if required with SAE 30/50 Universal tractor oil.

RUNNING UP PROCEDURE

PA921 Ti

Ensure that the rotor control valve is in "STOP" position, start tractor, engage P.T.O and allow the oil to circulate for about 5 minutes without operation of the armhead control lever. This will allow all the oil to circulate thoroughly through the return line filter.

Operate the armhead levers through their complete range ensuring that all movements are functioning correctly.

Place the flail head at a safe attitude and move the rotor control to "START" position. After initial fluctuation due to priming the rotor should settle to a steady speed. Increase P.T.O. speed to approximately 360 rpm. and run for a further five minutes before disengaging and stopping tractor.

Check the hose runs and observe that they are free from any pinching, chafing straining or kinks. Re-check the oil level in the tank and top up as necessary.

PA921 Si

Ensure P.T.O. lever is in neutral position, and isolate tractor hydraulic linkage. Start tractor and select external service supply on the hydraulic controls. Allow the tractor to run for several minutes before attempting to operate any of the machine control levers.

On operating move the levers through their complete range ensuring that all movements are functioning correctly.

Check the tractor rear axle oil level and top up if necessary.

Place the flail head at a safe attitude and bring tractor engine revolutions to 1000 rpm. to avoid stalling when the starting load is placed on the motor. Engage P.T.O. and allow the rotor to run for several minutes. Do not leave the tractor cab or allow anyone to approach the flail head at this time.

Caution

Do not allow the pump to continue working if the rotor does not turn—Overheating and serious damage to the pump can be caused in a very short time.

After running up the machine increase P.T.O. speed to approximately 360 rpm. and run for a further five minutes before disengaging the P.T.O. and stopping tractor. The reason for this running period under a no load condition is to thoroughly circulate the oil in the reservoir through the return line filter.

Check the hose runs and observe that they are free from any pinching, chafing, straining or kinks. Re-check the oil level in the tank and top up as necessary.

REMOVAL FROM TRACTOR

Select a firm level site for parking the machine.

Remove the parking feet, turn through 90° and re-locate in their housings.

Unscrew the lift ram tap and with the machine at approximately half reach in normal working position, i.e. not broken back, operate the hydraulic services until the flail head roller is horizontal and level with the feet on the main frame.

Disengage tractor P.T.O and remove

Disconnect stabilizer bars or loosen check chains as applicable.

Unbolt the control unit from the mounting pillar, remove from tractor cab and stow in a suitable location clear of the ground. On Si models only the supply and return hoses must be disconnected from the tractor and stowed with their ends covered and clear of the ground,

Raise the machine on the tractors linkage to take the weight off the yoke and remove the lower yoke pins.

Lower the tractor draft links and place machine firmly on the ground.

Remove draft links and the top link from the machine, drive tractor forward and remove yoke. Blank off the end of the return hose with plug or small plastic bag if a self seal coupling is not fitted.

STORAGE

If machine is to be left standing for an extended period of time, lightly coat the exposed portions of the ram rods with grease. Subsequently this grease which becomes contaminated with dust and grit should be wiped off before the rams are next moved.

If the machine has to be stored outside tie a piece of tarpaulin or canvas over the control assembly—do not use a plastic fertilizer bag which could lead to rapid corrosion.

OPERATION

LIMITATION

The Power Arm 921 Si and Ti has been designed as a light to medium weight hedgetrimmer; is ideal for work on hedges that have been regularly maintained and is capable of making a reasonable job in up to two years growth. The machine can be operated on either side of the tractor and the rotor has been designed to cut in either direction. Heavily overgrown or badly neglected hedges should be tackled with a shapesaw.

HIGHWAY WORKING

If it is intended to cut roadside hedges or to work in the vicinity where the public have access, it is a statutory requirement that suitable warning signs are placed at both ends of the work area. These signs should not be more than ½ mile apart (.8 Km). To further promote highway safety, the use of headlamps and a flashing beacon on the cab roof would be beneficial. Hazard warning lamps should not be used since an oncoming vehicle could easily misjudge braking distance in presuming the tractor approaching them is stationary.

WARNING

Always keep any bystanders at a safe distance and ensure that they do not stand in the potential line of any debris that may be thrown.

OPERATOR GUARD

Owners are reminded that it is illegal to use a flail without an efficient operator guard. The guard supplied as standard equipment with each machine attaches to the tractor cab with spring loaded hooks.

PREPARATION

Before commencing work, the operator should read the instruction manual thoroughly, paying particular attention to the SAFETY PRECAUTIONS printed in the front of the manual. It is the operator's responsibility to ensure that a safe code of practise is followed.

If the operator is unfamiliar with the control levers and thus the reach, height and angling of the flail head, a worthwhile exercise is to before commencing work choose a clear unobstructed site and operate the arms throughout their range of movement until the response to the controls and the 'feel' of the machine are familiar. Test yourself by making a dummy run alongside the hedge with the rotor stationary. This is a wise precaution for all operators and a must for the inexperienced.

Caution

The ability for the flail head to work closely alongside the tractor wheel in narrow lanes and for transport to fold within the overall tractor width can present a possible hazard for the flail head to contact the mudwing, rear lamp cluster etc, and cause damage.

Caution should be exercised when operating under these conditions and particularly when folding within the tractors width for transport.

MACHINE CONTROLS

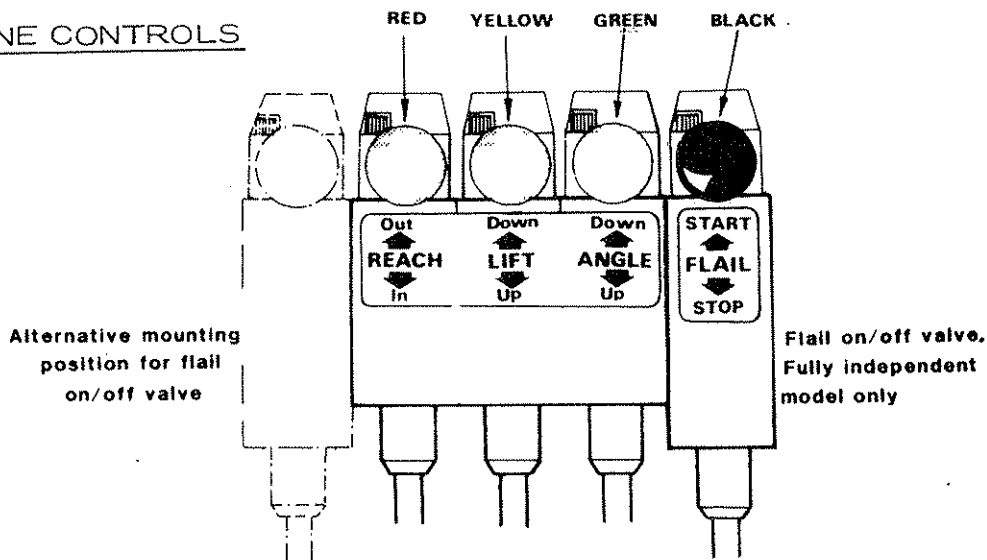

BREAKAWAY ACTION

When the flail head meets an obstruction and the tractor continues to move forward, the complete armhead which is hinged on the frame will be forced backwards and upwards at the same time in an effort to clear the obstruction. Resetting of the breakaway is completely automatic with the armhead returning to its working position under its own weight. Breakaway reset forces are absorbed by rubber damper.

TRANSPORT POSITION

With the armhead in the working position at right angles to the main frame, the flail can be raised and folded to close proximity of the tractor wheel. Where it is desirable to fold the machine to within tractor's overall width it is necessary to lock the armhead back in the breakaway position by engagement of the breakaway lock pin.

This is best done by releasing the lock pin, placing the flailhead on the ground and driving forwards, while at the same time operating the 'main arm down' lever.

The released lock pin will drop in and locate itself behind the breakaway bar when maximum position is reached. The flail head should then be angled inboard to a vertical position and rested on top of the 'T' frame.

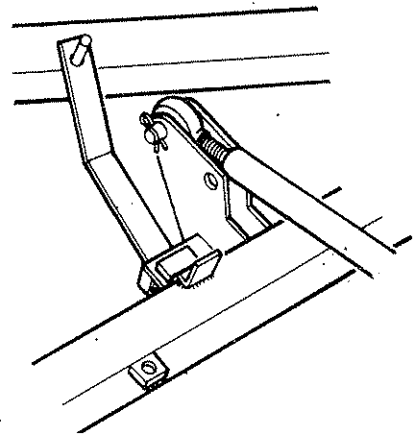

MOVING FROM THE TRANSPORT TO THE WORK POSITION.

To revert back to the working position it is only necessary to place the flail head firmly on the ground, drive the tractor forward sufficiently to take the weight off the breakaway bar, when the lock pin can then be raised and turned so that its head is held against the protruding lug on the frame.

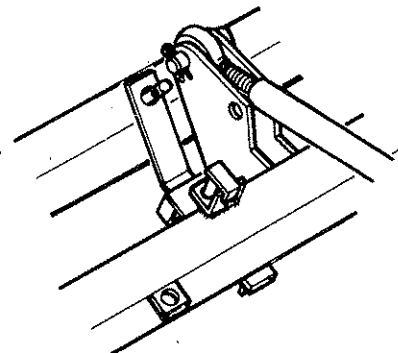

The arm can then be returned to the work position by either reversing the tractor or by operating the 'lift' control to raise the head which allows the breakaway mechanism to position the flail head for work.

ENGAGING DRIVE.

a) Fully independent model.

Ensure that the rotor control lever is moved to the 'STOP' position before engaging the P.T.O. shaft. Allow the oil to circulate for a minute or so before operating the armhead levers. Position the flail head in a safe position, increase the engine speed to a high idle and move rotor control lever to 'START'. After initial surging the rotor will run at an even speed. Starting the rotor this way reduces the starting loads imposed on the hydraulic motor and the drive splines.

b) Tractor supply model.

Place the flail head at a safe attitude and bring the tractor engine revolutions to 1000 r.p.m. to avoid stalling when the starting load is placed on the motor. Engage the P.T.O. and slowly increase revs. until operating speeds are attained.

FORWARD SPEED

Tractor ground speed is determined by common sense and experience. It should be slow enough to allow sufficient time for the flails to cut the work without overloading. It is obviously better to make a second pass or more in heavier growth to avoid undue strain.

TRACTOR POSITION

The position of the tractor in relation to the hedgerow will again be determined by experience. For a normal straight forward hedgerow the position should be such as to allow the reach ram to be in mid-stroke. This effectively allows the reach to be adjusted in either direction without altering the tractor's position.

OPERATING SPEED

The flail head should be run at a speed no higher than is needed to make a clean cut with no fall off in rotor speed. This also allows better control of the tractor and reduces the tendency of the operator to 'ride the clutch pedal'.

The recommended rotor speed is 2430 rpm.

To achieve these speeds it will be necessary to run the tractor engine to give a P.T.O. speed of 450 r.p.m.

<p>WARNING Never exceed 540 rpm on the P.T.O. shaft</p>

WORKING PRACTISES

It is the operator's responsibility to develop safe working procedures. From the first, develop good habits not bad ones, always:-

Make sure all guards are in position and in good condition.

Disengage the P.T.O. before stopping the engine.

Wait until the flail has stopped rotating before leaving the tractor seat.

Disengage the P.T.O. and stop the tractor engine before making any adjustments.

Check frequently that all nuts and bolts are tight.

Use the breakaway latch and lift ram tap when transporting on the highway.

OVERHEAD OBSTRUCTIONS

Remember the machines are approximately eleven feet high in the folded position and therefore care must be taken when manoeuvring in and out of buildings or in the vicinity of overhead obstructions such as power lines or telephone cables.

WARNING

To avoid the possibility of flashover in the vicinity of high voltage overhead power lines never work closer than **1.5 metres** minimum. If in any doubt consult the local electricity board way leave officer for advice on a safe plan of working.

WIRE TRAP

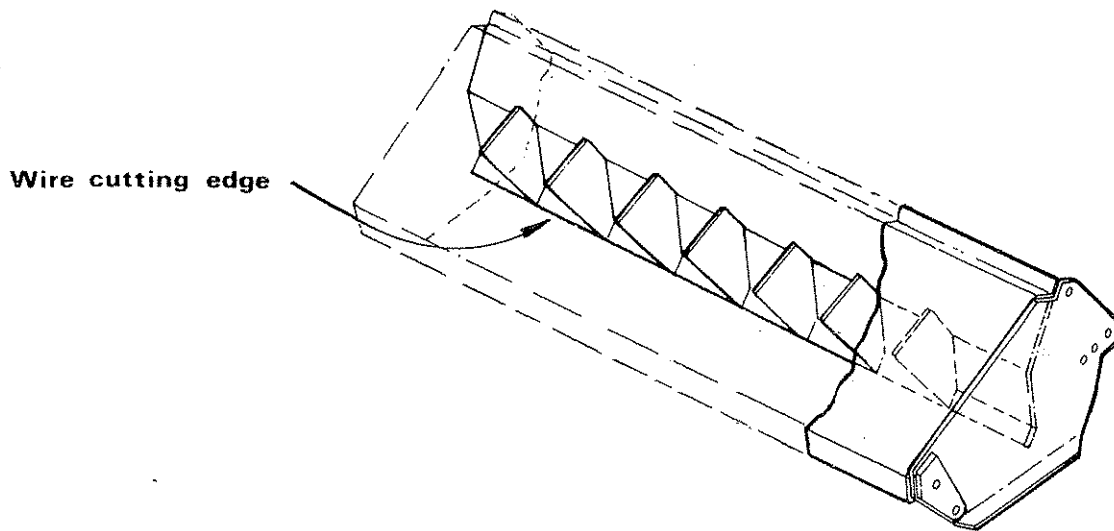

Both flail hoods are equipped with a wire trap. The trap consists of a steel plate welded across the underside. Any loose ends of wire which are picked up and carried round by the rotor are cut by the edge of the metal plate and fall harmlessly to the ground. This plate should not be interfered with or modified in any way.

Furthermore this wire trap does not relieve the operator of the responsibility of checking and cleaning the flail when it is suspected that wire has caught in the rotor.

WARNING

If any wire is picked up by the rotor the machine should be stopped immediately and the rotor cleared before proceeding.

HEDGE CUTTING PROCEDURE

Preliminary precautions.

The work area or hedgerow should be carefully inspected for wire, steel posts, large stones, bottles and other dangerous materials and removed. The position of any immovable objects should be particularly noted or identified i.e. with a fragment of plastic sack to avoid running into them with the flail. Should the rotor accidentally strike anything of a hazardous nature, the machine should be immediately stopped and the rotor examined for damaged or missing flails which should be replaced to retain rotor balance. Continuing to work the flail head with the rotor out of balance will cause vibration which can rapidly damage the rotor bearings and break up the flail casing.

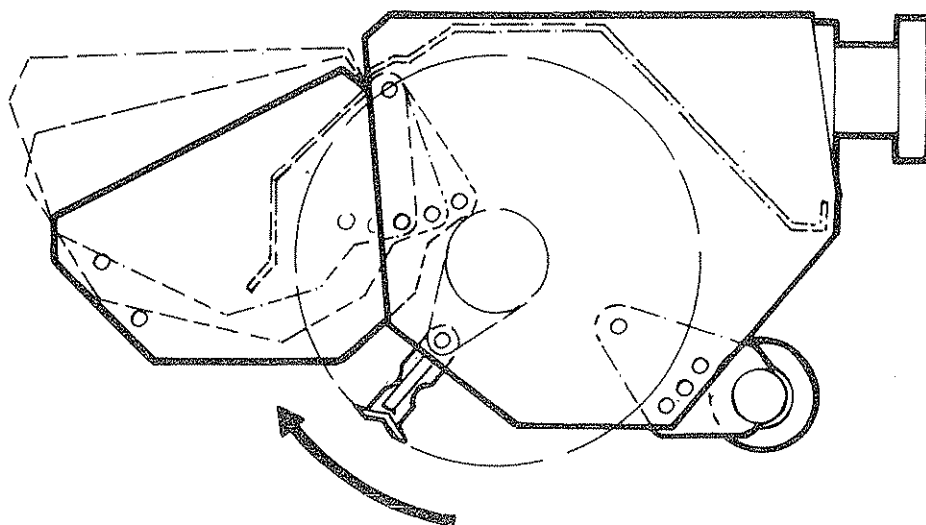

Upward Cutting

The flail head is assembled at the factory for the flails to cut with an upward motion. Upward cutting produces a cleaner finish minimises split stems and is ideal for a light hedge that has been regularly maintained. The front hood part No. 71-90-347 must always be in position when hedging with an upward cutting action. It is pivot mounted and can be adjusted to three working positions. To minimise the throwing of debris especially when roadside cutting the hood should be adjusted to its lowest position. Raising the hood will allow longer material to be cut but there will be a greater tendency for debris to be thrown.

Roller

The roller is adjustable vertically to three positions. For hedge cutting it is generally set in the highest position which positions the roller slightly above the flails. The roller helps to prevent the flail head from bouncing and **sinking** into the hedge thus assisting in maintaining a level cut. The two lower positions may be used when making the ground cuts. These locate the roller below the flails which prevents the scalping of the earth and decreases the likelihood of hitting or throwing stones. Never attempt to operate the flail **without** the roller in position. It shields the flails, acts as a chopping bar and eliminates the chances of long lengths of cut material being thrown.

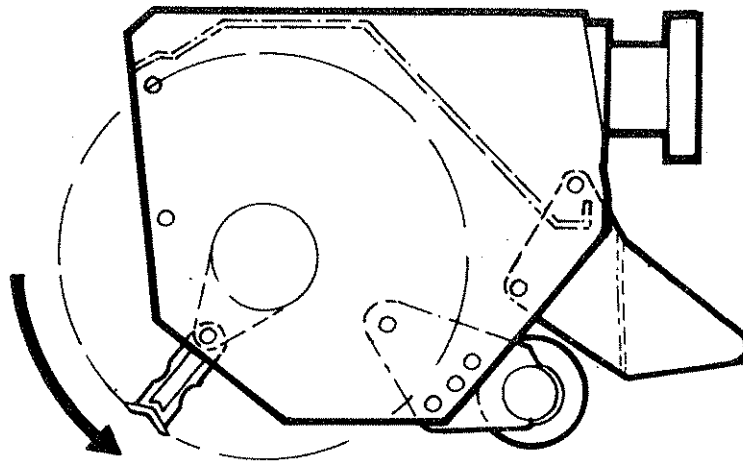

Optional Downward Cutting

It is possible to reverse the rotation of the flail for downward cutting in heavy growth. This chopping action subjects the rotor to violent usage and should therefore be avoided whenever possible.

For downward cutting a rear hood Part No. 71-90-253 which is non adjustable must be used to deflect the cut material downwards into the hedge. It is permissible to remove the front hood to allow larger material to pass under the flail head.

Reversing rotation

Fully extend the armhead and lower flail to the ground to minimise oil loss. Release the hoses from the flail motor rigid pipes and interchange. Do not interchange the flail supply and return hoses at any other point as the hose routing and cross overs in the installation are necessary to allow the hoses to flex correctly during arm movements. Also do not interchange at the rotor control valve as the return hose is of single wire construction and is insufficiently robust to cope with motor supply pressures.

To ascertain the direction of cut without running the machine the following applies.

Connection MP – lower motor rigid pipe	}	upward cutting
Connection MR – upper motor right pipe		
Connection MP – Upper motor rigid pipe	}	downward cutting
Connection Mr – Lower motor ridid pipe		

In addition the hoses can be recognised by the two stripes on the motor pressure supply hose and the single stripe on the motor return hose.

Hedge-shape

Local practice and customs as well as the requirement; be it a stockproof barrier, a windbreak to resist soil erosion or as a sanctuary to protect wild life will each have their part to play in influencing the desired finished shape of the hedgerow.

A hedge cut in the shape of an 'A' although rather wider and so taking up more ground will be encouraged to send out new growth from the bottom. The stubbly ends from the ground to the top can further discourage stock and the wide dense bottom will promote conservation of wild life.

A hedge with vertical sides and an apex top is an alternative which has found favour in many parts of the country. The sloping top encourages light to penetrate and promote growth in the lower regions of the hedge. The sloping top also assists to shed heavy falls of snow which can accumulate and break a hedge down.

Although a box-shaped hedge, flat across the top and with square corners may look very tidy in its early stages it is prone to dying off in the bottom while being encouraged to grow in the top. After a few years this type of hedge can become 'buck-headed' and is always susceptible to damage by snow.

Cutting sequence

Operator preference will ultimately decide on the order of cutting. Where it is difficult to determine the original hedge line because of overgrowth, a recommended method is to start by siding up the hedge first, if necessary making more than one pass.

A second cut should then be taken at an incline along the hedge top and again if there is prolific growth it may be necessary to make more than one pass until the hedge is reduced to the height and contour required.

Finally, finish with a ground cut and for this, the roller should be lowered. This ground cut defines the base line of the hedge, severs brambles and rubbish that encroach out from the bottom, and further mulches the toppings that have fallen.

Note: Flails are more prone to accidental damage and blunting by stones on a ground cut. Therefore when convenient this should be left to the last.

Where the hedge has been well maintained in the past it may be found better to cut the top before siding up.

WARNING

Do not be tempted to make a vertical cut on the far side of the hedge. This would entail cutting 'blind' and the rotating flail would be capable of throwing debris through the hedgerow in line with the operator.

Where both sides of a roadside hedge are to cut, always cut the field side first. The uncut roadside helps to reduce the amount of debris being flung through the hedge into the road. Also by sloping the vertical cut to give an 'A' shape, debris is thrown down into the hedge bottom and the spread of material is reduced.

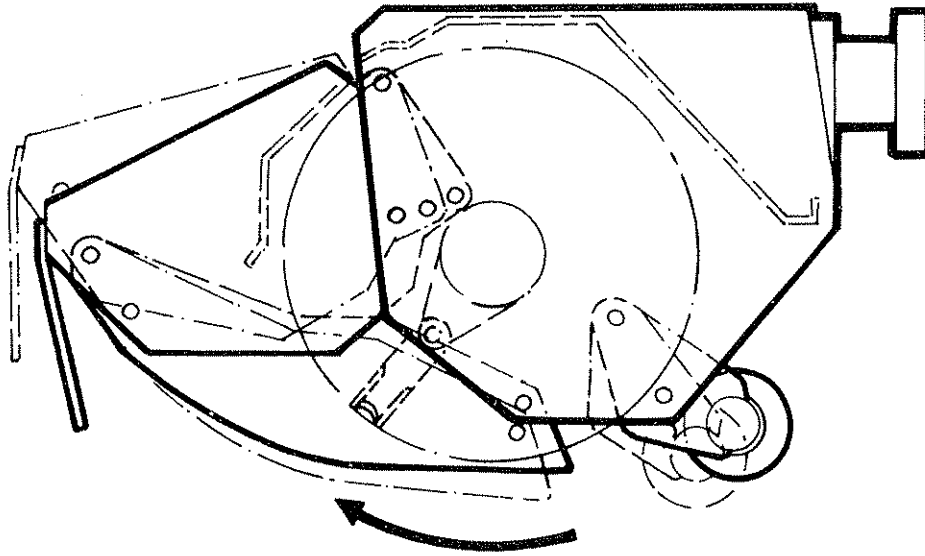

GRASS CUTTING

The flails must rotate in an upward motion for grass cutting. The vacuuming effect created by the rotating flails causes the grass to stand erect allowing a neater cut finish to be achieved. The front hood, which can be used in either of the two lower positions depending on the length of material to be cut, is fitted with eight rubber flaps which shield the rotor at the front and direct all cut material up under the hood and discharging it down on to the ground at the rear.

The front hood provides a choice of two reinforced mounting locations for the front of the skid, the higher one of which is used when the hood is in the lower position and vice-versa. The rear of the skid also provides two alternative mounting locations thus giving four alternative skid positions to suit the length of material to be cut and type of work to be done.

For grass cutting the roller can be set in either of the two lower positions depending on the length of finish required.

REAR FLAP (Optional extra for upward cutting)

For upward cutting either hedge or grass an optional rear flap is available to further restrict the spread of cut debris at the rear.

It is vigorously stressed that this flap is not an alternative for a rear hood should rotation be changed to cut in a downward motion.

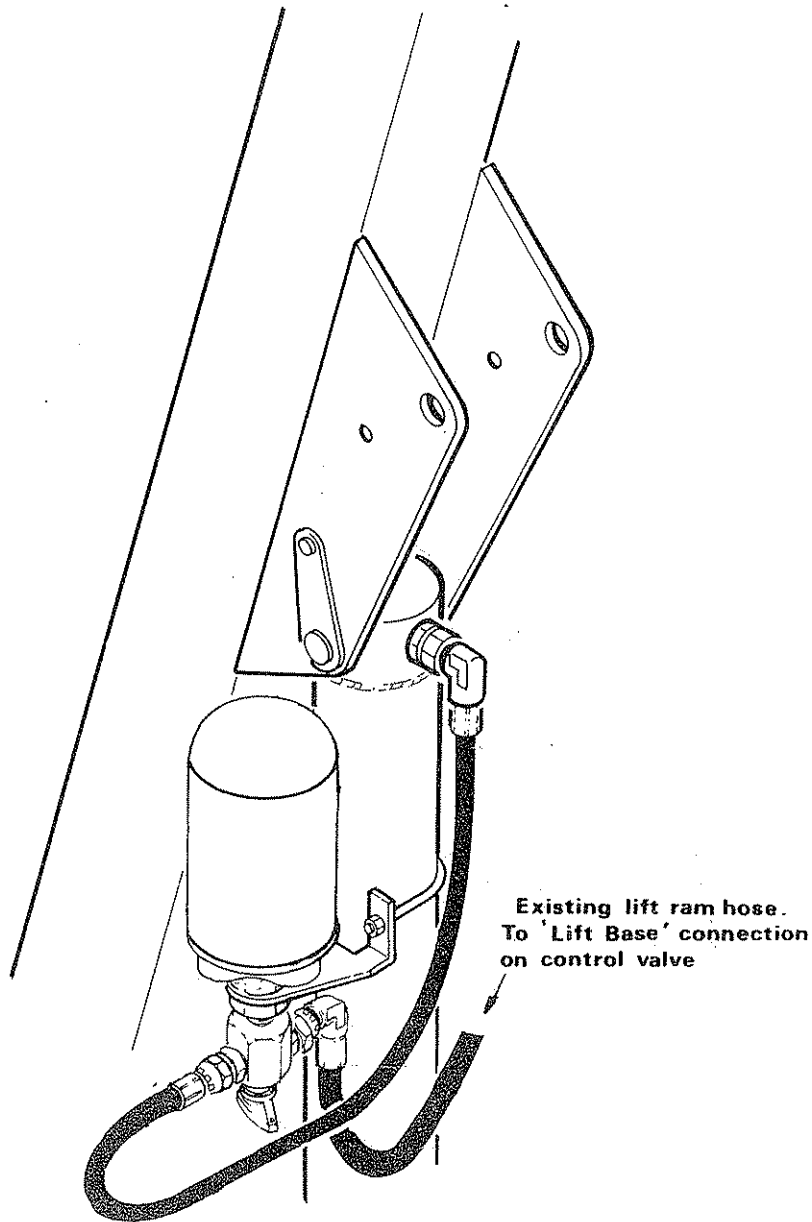

LIFT FLOAT KIT (optional extra)

Grass flailing can be a slow tedious task requiring a high degree of operator concentration especially when working on a rough or undulating ground. A Hydraulic float kit is available which is mounted as shown in the vertical position clamped to the lift ram barrel.

In work, with the stop tap open the flail runs along the ground automatically lifts and rides over any bumps. Any shock loads are absorbed by the accumulator which is pre-charged with nitrogen to 600 p.s.i.

To obtain optimum working performance the lift control should be operated to take approx. fifty per cent of the flail head weight off the flail roller. This is important as with too little weight on the roller the flail head will tend to remain in the air after riding over a bump and leave uncut areas of grass while with too much weight on the roller the float will be inoperative; the ground will be scalped in places and increased flail wear, loss, or damage to flails could occur.

To revert to hedge cutting or to use the flail without it running along the ground the stop tap should be closed to isolate the accumulator.

MAINTENANCE

LUBRICATION

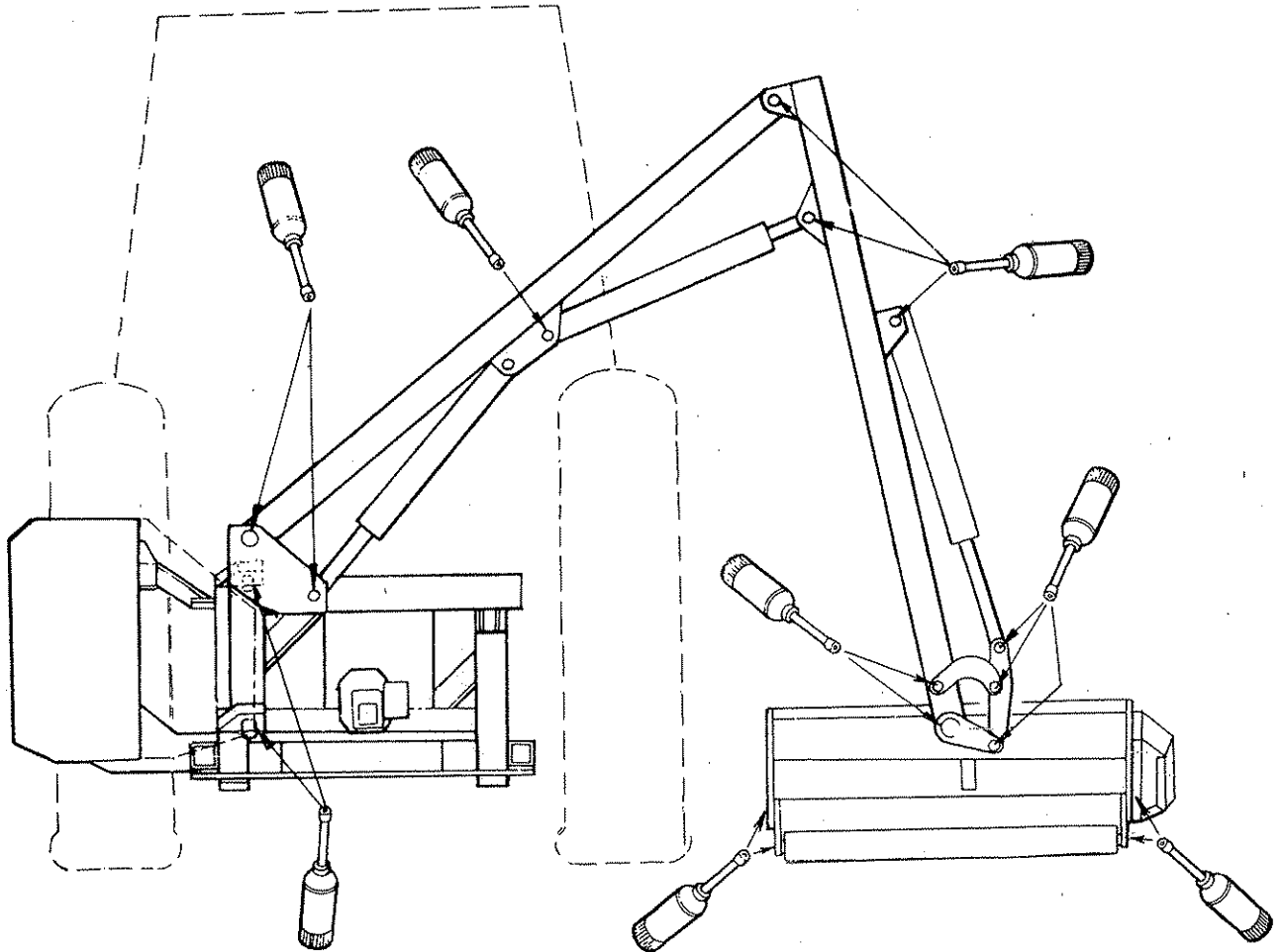

General

Refer to the lubrication diagram and grease daily all points shown.

Power take-off shaft

The PTO shaft should be regularly examined to ensure that it is in good condition together with the guards. The universal joints should be greased very sparingly i.e. one shot weekly.

Note: Overgreasing a universal joint will blow-out the cork or neoprene sealing rings that exclude the dirt from the needle bearings inside.

The two halves of the plastic guard should be checked daily to ensure that they can spin freely on the shaft. The nylon slip rings which support the guard on the drive shaft should be lightly greased at weekly intervals.

The telescopic drive shaft should be similarly separated and grease applied to the internal shaft at approximately 100 hour intervals.

HYDRAULIC SYSTEM

Oil supply

Check daily the oil level in the reservoir.

No fixed time period can be quoted for oil changes as operating conditions and maintenance standards vary so widely. Although the oil does not wear out, it does eventually break down through contamination, oxidation and condensation. Continual operation of the machine beyond its rated capacity to almost the stall point of the rotor can cause overheating which produces insoluble gums, sludge, varnish and acids. Overheated oil tends to give a sluggish performance and causes earlier failure of seals and 'O' rings. Burnt and scorched oil odours and the oil darkening and thickening are all signs of oxidation and indicate the oil should be changed.

Moisture which results from condensation can become entrapped in the oil and cannot be removed by filtration so that contamination is a progressive factor.

Contamination can be reduced by:-

- i) Carrying all hydraulic servicing in clean, dust-free surroundings
- ii) Cleaning off around the reservoir cap before removal, and keeping that area clean
- iii) Using clean containers when replenishing the system
- iv) Regular servicing of the filtration system

Filtration Maintenance

The machine is protected by a 125 micron suction strainer and a low pressure 10 micron full flow return line filter:

- i) Suction strainer.
The strainer is fixed in position within the reservoir.
Should symptoms of pump cavitation or spongy intermittent operation occur the tank must be drained and flushed out with a suitable cleaning agent eg. clean diesel oil
- ii) Return Line Filter.
The element should be changed after the first 50 hours and thereafter at 500 hour intervals. It is important to note hours worked as if the filter becomes blocked an internal by-pass within the canister will operate and no symptoms of filter malfunction will occur to jog your memory.

ROTOR VALVE

No servicing is required of the rotor control valve other than a periodic check for oil leaks. The relief valve assembly within the block is calibrated by shims to give a setting of 3000 PSi (210 Bar). On no account should this pressure be exceeded.

The operating spool and block are selectively assembled and cannot be supplied as separate components.

FLOAT KIT ACCUMULATOR TEST

If a leak of Nitrogen is suspected a test with soapy water around the valve thread and core area should be carried out.

A replacement charge valve assembly can be fitted after the accumulator has been fully discharged. It is essential that this work is carried out by the dealer or distributor who must have the facilities for recharging. The accumulator can be removed for this purpose. If oil is leaking from the area of the charge valve then the internal butyl bag is damaged and the accumulator is scrap.

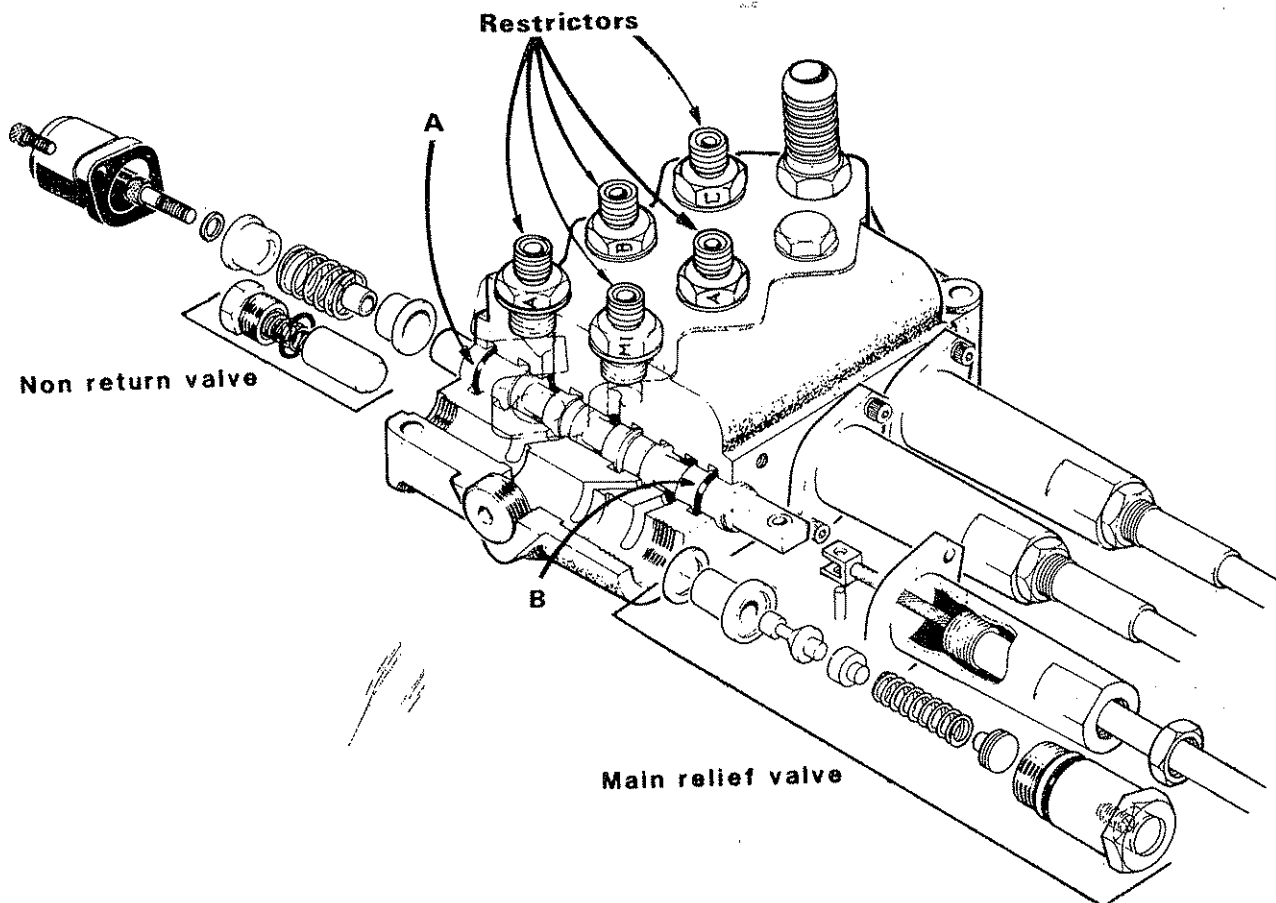

CABLE OPERATED ARMHEAD CONTROL VALVE

Replacing damaged or worn spool 'O' rings.

Release the locknut located on the cable at the back of the sleeve.

Remove the two allen headed capscrews that secure the sleeve to the valve block and screw the sleeve back down the threaded portion of the cable to reveal the clevis pin which is then withdrawn from the end of the spool. Take care not to lose the roller in the eye of the spool end.

Remove the spring cover at the opposite end of the spool and remove the setscrew to release the return spring assembly.

Pull the spool through the block from the cable end until 'O' ring marked 'A' is accessible. Remove the 'O' ring from its groove using a smooth edged hook.

Completely remove the spool from the block out of the return spring end.

Remove 'O' ring marked 'B' and refit a new 'O' ring.

Lightly oil the spool and replace it in the block from the return spring end pushing it through just far enough to clear 'O' ring groove at 'A'.

Fit new 'O' ring in groove 'A'.

Push the spool back through from the cable end far enough to re-assemble the return spring assembly and cover.

Replace the clevis pin in the spindle eye and re-assemble the sleeve. Adjustment of the threaded section being correct when the handle on the control box is in a vertical position. Re-tighten the locknut.

Note: Owing to the sharp edges in the design of the spool, failure to follow the above procedure could result in damage to the new 'O' rings resulting in external leakage.

The spools are selectively assembled, matched with their mating bores in the block and should not be interchanged.

Main Relief Valve

The main relief valve is pressure set at the factory to 2000 PSI (140 Bar) and is non adjustable. A sticking relief valve will probably cause overheating and /or loss of power. If this is suspected it should be dismantled and examined for dirt and damage. Undo the large hexagon housing, the relief valve spring, needle and seat can now be withdrawn. If difficulty is experienced in extracting the seat remove the non-return valve at the opposite end of the gallery and drive out with a soft brass drift. Take care not to damage the copper sealing washer positioned between the seat and the locating shoulder in the block.

Blow out the valve with compressed air and examine the components for damage. These components are specially hardened steel and should only display a seating witness - any further damage will require the complete valve to be replaced.

CAUTION.

Under no circumstances be tempted to add shims into this valve in a misguided attempt to increase the power of the machine. This could damage the tractor, and may cause personal injury.

Non Return valve

The non-return valve prevents the feed back of oil from the service ports to the pump. It is unlikely to need attention but if removed for cleaning a new 'O' ring should be fitted.

Restrictors

Restrictor unions which are identified by code letters are calibrated for correct speed of operation. The restricted hole should not be enlarged or the unions interchanged in the block.

CABLES

The cables operate on a push/pull system with the spool centering springs always returning the spool to the neutral position when the handle is released.

Care should be taken during installation and operation to ensure that the cables are not trapped or kinked. Any abrasion or damage to the outer casing should be sealed with plastic insulation tape to avoid moisture penetrating.

No routine adjustment of the cables are necessary as they do not stretch. The threaded collar is correctly adjusted when the lever is in a vertical position in its housing allowing and equal amount of travel in either direction.

On PA 921 Ti models the rotor on/off valve requires particularly accurate setting of the cable and is carried out as follows:-

Assemble cable end in the stop/start lever block

Pull the return control valve spool out until it stops

Set flail control lever in 'stop' position

Attach cable to spool end

Screw cable sleeve towards the valve until it lightly touches the face of the control plate.

Screw the cable sleeve flange to the control plate

Tighten cable locknut

Operate the stop/start lever to ensure the correct operation of the detents in both positions.

CAUTION On no account should any attempt be made to lubricate the cables which are assembled with a special lubricant during manufacture.

NOTE: Take care to ascertain the correct cable connections on both the control unit and the valve in the event of cable replacement.

HYDRAULIC PUMPS

All pumps are clockwise rotation. No routine maintenance is necessary other than than a periodical check for tightness of the mounting bolts and a visual check for oil leakage especially around the pump supply and pressure unions. Where two hose clips are used on the pump supply hose, their worm drive barrels should be placed opposite each other at 180°. When fitted with tandem pump assembly do not attempt to operate the armhead rams without the 3/4 BSP flail hoses being interconnected. The tandem pumps share a common seal drain and both circuits must be intact before the pumps are run.

Pump servicing is limited to replacing seals, gaskets and 'O' rings. Servicing should take place under clean dust free conditions. Pumps should be thoroughly washed and their end plates and body lightly identified with scribe marks to ensure correct re-assembly.

When re-assembling, lubricate all components with clean oil and tighten down the securing bolts in a diagonal sequence to pull the pumps squarely together, finally tightening to a torque load of 4 - 5 Kgm (30-37 lbs/ft) M10 Setscrew
2½ - 3 Kgm (18-22 lbs/ft) M8 Setscrew

Check for freedom of rotation. The pumps should turn freely under a hand load applied on a 6" radius arm. If tight, the lobe seals and/or backing washers have been trapped and the unit must be dismantled to rectify this.

After installation, the serviced pumps should be run for several minutes under a 'no load' condition before load is gradually applied. During this time frequent checks should be made of the pump casing temperature. An excessive temperature rise will indicate that the pump has been assembled incorrectly.

Generally it is unwise to replace major components since they have to be matched in sets. Unless this is done the pump will be inefficient, resulting in overheating and power loss. No detailed parts breakdown is shown, but factory reconditioned units are available within our service exchange scheme.

HYDRAULIC MOTOR

Servicing of the hydraulic motor should be limited to replacing seals, gaskets and O rings. Components of the motor are matched to close tolerances and are therefore not replaceable as individual parts.

The torque setting of the cap screws is 6-7 Kgm (40 - 47 lbs/ft)

To remove the drive coupling from the shaft use a tool of the sprocket type to remove it. Do not attempt to remove the coupling by hammering or leverage as this will damage the motor internally.

Replacing shaft seals

The double shaft seal assembly must be assembled with the 7 m.m. wide single lip seal fitted first with the 1 m.m. thick lip support washer on top. The back of the double lip seal should be filled with a light grease before fitting with the wiper lip outermost.

The seal kit, Part No. 86 99 166 is a universal Cassapa motor sealkit. It may contain more seals than are necessary; care must be taken in selecting the correct seal to use.

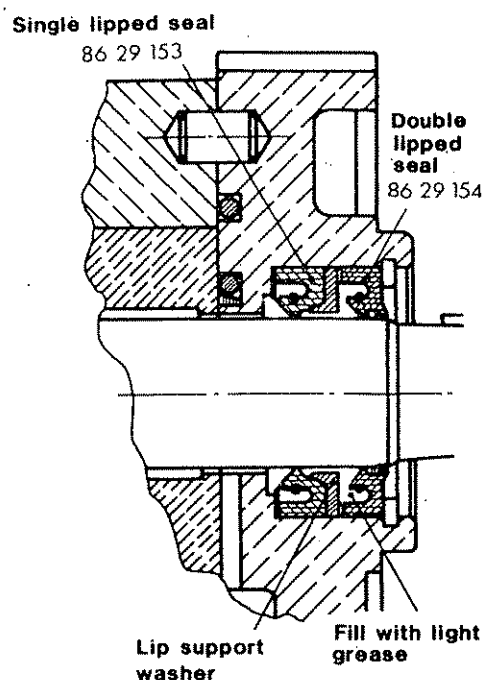

HYDRAULIC RAMS

a. Ram seal replacement – general information.

Whenever possible the ram should be removed from the machine and cleaned – off before dismantling on a clean work-bench.

When using a bench vice do not apply excessive pressure to the ram cylinder – use soft metal jaws when grasping the ram-rod.

Remove scores and nicks on the ram-rod by using a fine oil stone.

Do not use a file or emery cloth

Take the opportunity to replace all seals whilst the ram is stripped down.

Lubricate all new seals prior to reassembly.

b. Angling ram.

Unscrew the gland and withdraw the complete rod assembly. Slacken piston grub screw, unscrew the piston and slide off the gland housing.

Gland Seals

Replace as necessary. Ensure seals are replaced in the position from which they were removed.

Piston Seal.

Remove split members of the piston seal and then, using a soft lever which will not scratch the piston lift the remaining seal components from the piston. Replace with new seals in reverse order.

Refit gland housing on the rod taking care when easing the wiper seal over the piston rod shoulder.

The piston is locked onto the rod with a medium strength thread locking fluid such as 'Permabond A113', 'Loctite Nutloc 242', 'Dunlop Nutloc SAS110', 'Tru lock Nutgrade 375' or 'Hermetite Torqueseal M '.

The threads must be cleaned with a suitable solvent to remove oil and thoroughly dried before applying a complete film of the locking fluid to the rod threads. The piston should be screwed on, tightened firmly and left for 30 minutes before filling with oil and 1 hour before pressurising.

c. Reach ram

Unscrew the gland nut and withdraw the complete rod assembly.

Gland seals

Replace as necessary ensure that the seals are replaced in the attitude and position from which they were removed.

Piston seals

Change piston seals as angling ram. In addition do not forget the 'O' ring on the piston rod.

Refit the gland nut and housing on the rod taking care when easing the wiper seal over the piston rod shoulder.

Screw the piston firmly back onto the rod, re tighten the grub screw and centre pop the access hole to secure.

d. Lift ram

The lift ram is a single acting ram.

Unscrew the cylinder head. Withdraw the head and ram rod from the barrel and separate.

Renew all seals including the rod wear ring taking care to replace new seals in the same position and attitude from where they came.

Replace the rod and carefully slide the cylinder head complete with it's seals over the nose of the rod. Screw firmly into position the cylinder using 'Permabond A 113' or its equivalent.

Lift ram tap

Should an external leak appear dismantle the tap and renew the 'O' ring and anti extrusion ring taking care to replace them in the position from which they came.

HYDRAULIC HOSES

The condition of all hoses should be carefully checked during routine service of the machine. Hoses that have been chafed or damaged on their outer casing should be securely wrapped with waterproof adhesive tape to stop the metal braid from rusting. Hoses that have suffered damage to the metal braid should be changed at the earliest opportunity.

Hose replacement

- a. Replace one hose at a time to avoid the risk of wrong connections
- b. When the hose is screwed to an additional fitting or union, use a second spanner on the union to avoid breaking both seals.
- c. Do not use jointing compound on the threads.
- d. Avoid twisting the hose. Adjust the hose line to ensure freedom from rubbing or trapping before tightening hose end connections.

Before changing hoses study the installation these are carefully calculated to prevent hose damage during operation. Always replace hoses in exactly the same manner. This is especially important for the flail hoses where they must be crossed, upper to lower, at the dipper and head pivots. The 90° elbows at the head bracket must point directly across the pivot and the hoses must have no slack at this point.

Two hose clips are provided at either end of the large bore suction and return hoses. These should be positioned so that their worm drive barrels are opposed at 180° to reduce the possibility of air entering the system.

Hose warranty

Warranty is limited to replacement of hoses which have failed due to faulty materials or manufacture. Warranty will not be considered on hoses that have suffered damage by abrasion, cuts or being pinched or trapped while in work. Neither will a claim be considered where a hose end has been damaged by a blow or where the threads or unions have been damaged by overtightening.

P.T.O. GEARBOX

The gearbox is rigidly bolted on to the main frame and has a filler plug. Oil level is correct when level with the filler plug aperture. The gearbox oil should be changed every two years or at 1000 hour intervals; whichever occurs first. The capacity of the gearbox is .25 litres ($\frac{1}{2}$ pints) S.A.E. 30/50 Tractor universal oil.

FLAILHEAD

Frequently inspect the rotor assembly for damaged or missing flails. Bolts and nuts securing the flails to the rotor should be regularly checked and kept tight. The correct torque setting for these locknuts is 135 Nm (100 lbf/ft). Use only the correct flail bolt and locking nut. Check the flail pivot bushes for possible damage or wear. They do not require oil.

Do not attempt to run the rotor with flails missing. Im-balance will cause severe vibration and can rapidly damage the rotor shaft bearings. As an emergency measure if a flail is broken off or lost, remove another on the opposite side of the rotor to retain balance. Always replace flails in opposite pairs and never match up a new flail with a re-sharpened one which will of course be lighter.

Blunt flails absorb a lot of power and leave an untidy finish to the work. They should be sharpened on a grindstone or with a portable grinder periodically. Wear protective gear when sharpening flails.

Ensure that the bearing housings and hydraulic mounting nuts and bolts are kept tight. They should be checked during servicing.

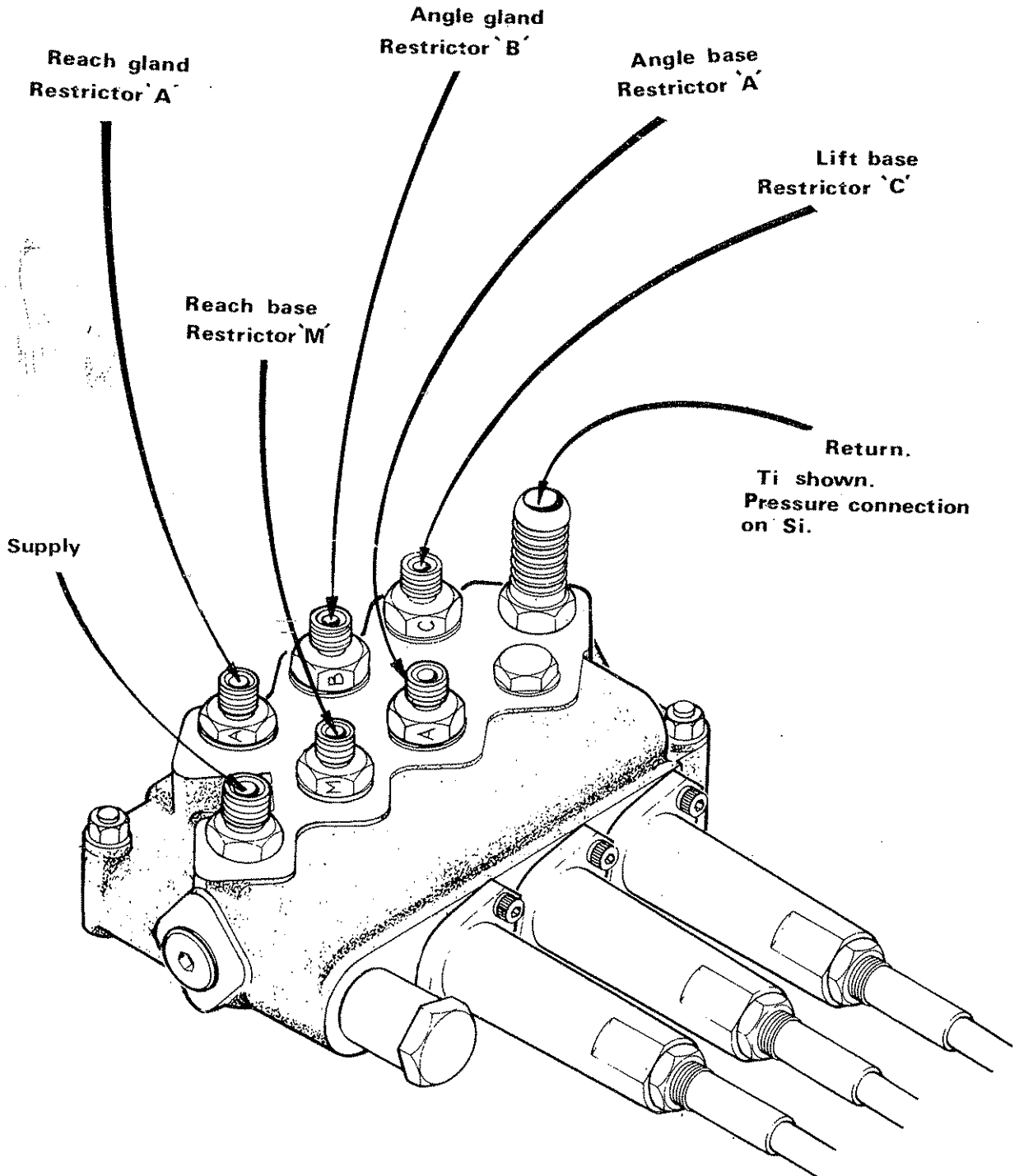

SPARE PARTS MANUAL

FOR BEST PERFORMANCE....

USE ONLY McCONNEL SPARE PARTS

To be assured of the latest design improvements purchase your genuine replacements from the original equipment manufacturer F.W.McConnel Ltd. through your local dealer or stockist.

Always quote machine type and serial number as well as the part number.

Design improvement may have altered some of the parts listed in this manual - The latest part will always be supplied when it is interchangeable with an earlier one.

Model

FRAMES & STABILISER

McCONEL

Temeside Works, Ludlow,
Shropshire, SY8 1JL, England.
Telephone: (0584) 3131.
Telex 35313. Facsimile: (0584) 6463.

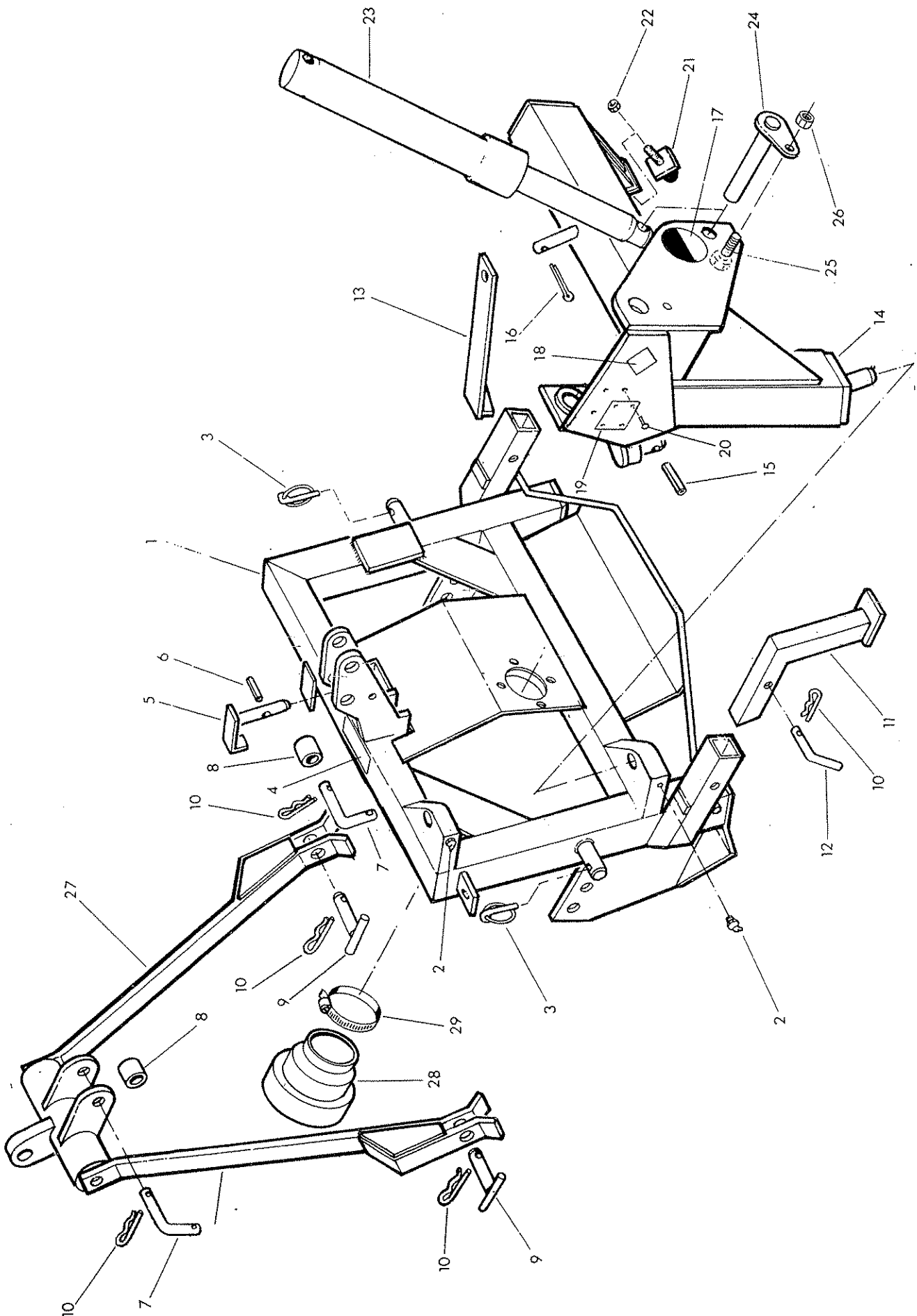
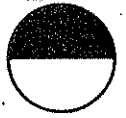

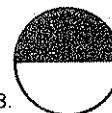

Ref.	Part No.	Qty.	Description
FRAMES AND STABILISER			
1	71-92-312	1	Main frame
2	09-01-125	2	Greaser 1/8 BSP 67 $\frac{1}{2}$ ⁰
3	04-31-217	2	Linch pin
4	71-35-295	1	Sticker - 'Tighten check chains'
5	71-92-038	1	Breakaway lock pin
6	04-25-630	1	Spring dowel \varnothing 6 x 30
7	71-92-026	2	Top link pin
8	14-67-063	2	Sleeve
9	71-92-027	2	Stabiliser pin
10	04-31-105	6	Spring cotter
11	71-92-307	2	Stand leg
12	71-92-023	2	Leg pin
13	71-92-043	1	Breakaway strap
14	71-92-317	1	'T' frame
15	04-21-832	1	Spring dowel $\frac{1}{4}$ " dia x 2" long
16	95-01-406	1	Split pin \varnothing 5 x 40
17	12-90-296	1	Sticker "Logo roundel"
18	71-05-130	1	Sticker "Read instruction book"
19	71-92-020	1	Serial Number plate
20	71-03-230	4	Pop rivet 1/8" dia
21	13-37-114	1	Buffer including nut
22	01-41-003	1	Self locking nut 3/8 UNF
23	71-92-049	1	Lift ram assembly (see page 62)
24	71-92-040	1	Pivot pin - lift ram rod
25	93-13-066	1	Setscrew M12 x 30
26	91-43-006	1	Self locking nut M12
27	71-92-327	1	Stabiliser
28	71-11-038	1	P.T.O. guard
29	09-04-114	1	Hose clip
30	71-36-330	1	P.T.O drive shaft - not illustrated

Model

MAIN ARM

McCONEL

Temeside Works, Ludlow,
Shropshire, SY8 1JL, England.
Telephone: (0584) 3131.
Telex 35313. Facsimile: (0584) 6463.

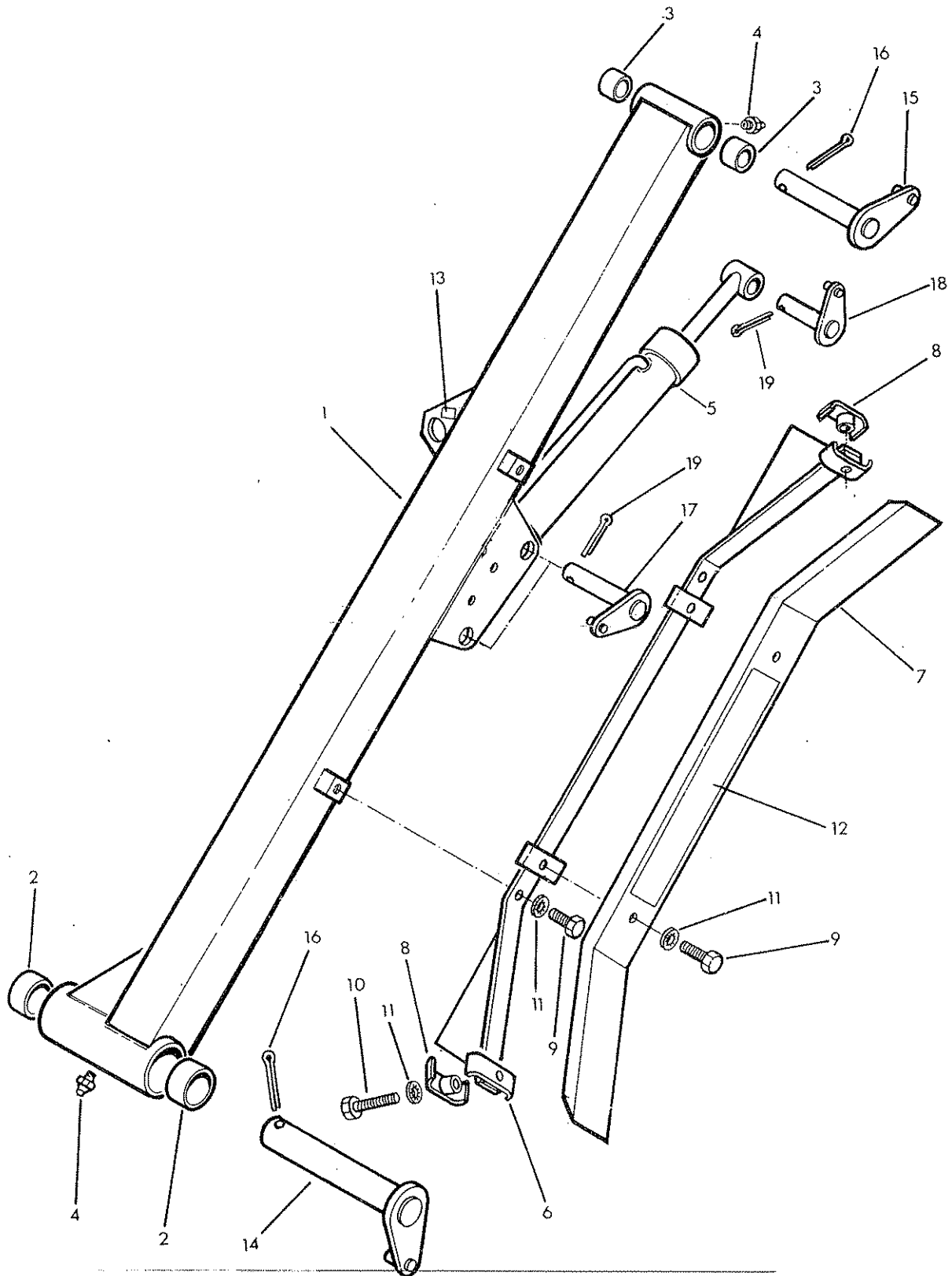

Model

McCONEl

Temeside Works, Ludlow,
Shropshire, SY8 1JL, England.
Telephone: (0584) 3131.
Telex 35313. Facsimile: (0584) 6463.

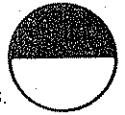

Ref.	Part No.	Qty.	Description
			MAIN ARM
1	71-92-319	1	Main arm
2	72-13-023	2	Bush-main arm pivot
3	71-01-134	2	Bush - dipper arm pivot
4	09-01-121	2	Greaser - 1/8" BSP straight
5	71-92-050	1	Reach ram assembly (see page 63)
6	71-93-313	1	Hose guide
7	71-93-321	1	Hose cover
8	71-93-014	2	Hose clamp
9	93-13-055	4	Setscrew M10 x 25
10	92-13-085	2	Bolt M10 x 40
11	91-00-305	6	Internal serrated washer \varnothing 10
12	12-90-255	1	Sticker 'McConnel'
13	60-55-002	1	Sticker 'Sling here'
14	71-92-039	1	Pivot pin - main arm
15	71-92-042	1	Pivot pin - dipper
16	95-01-509	2	Split pin \varnothing 10 x 50
17	71-92-041	2	Pivot pin - Lift and reach ram base
18	71-92-024	1	Pivot pin - Reach ram rod
19	95-01-406	3	Split pin \varnothing 5 x 40

Model

DIPPER ARM & ANGLING

MCCONEL

Temeside Works, Ludlow,
Shropshire, SY8 1JL, England.
Telephone: (0584) 3131.
Telex 35313. Facsimile: (0584) 6463.

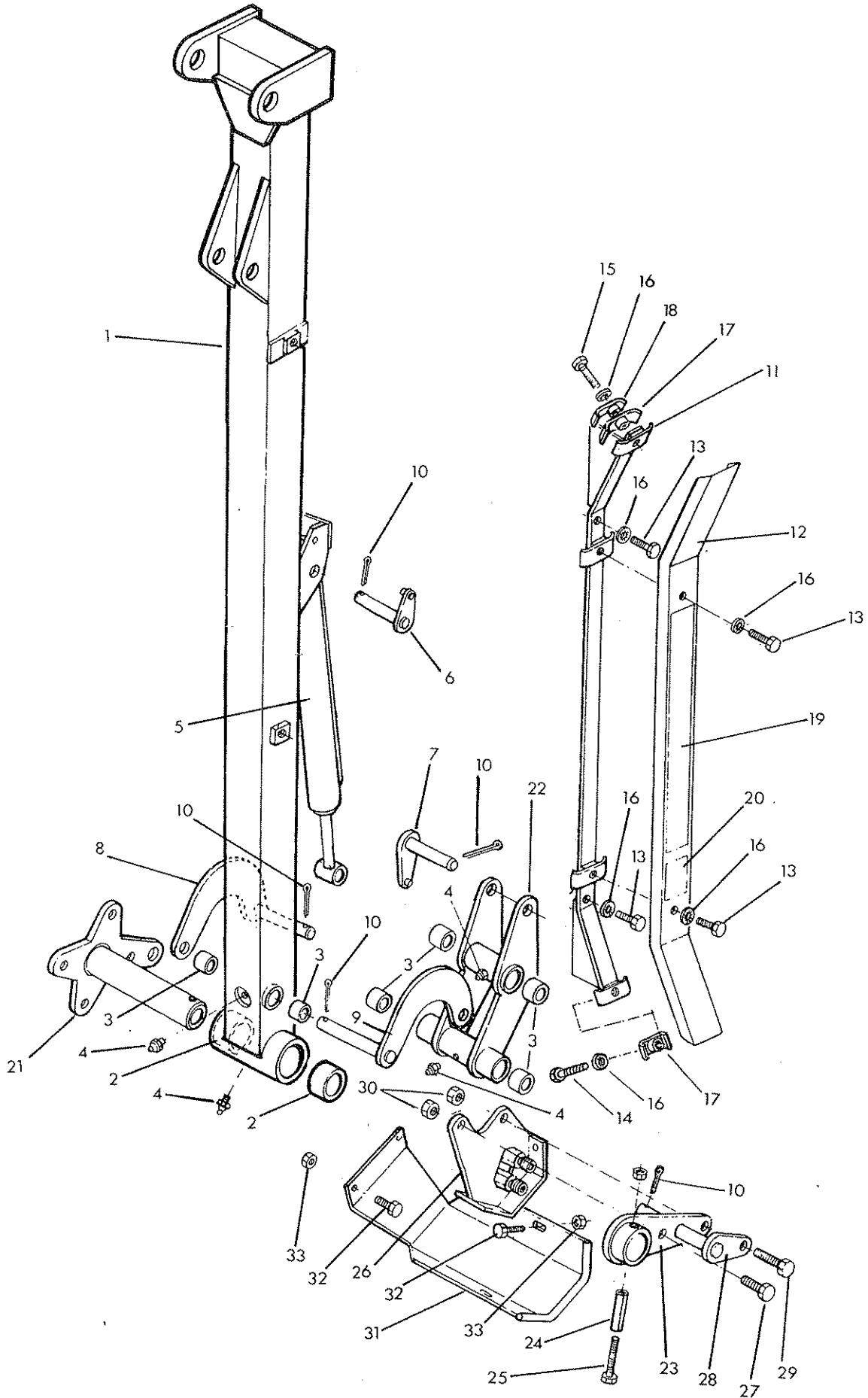

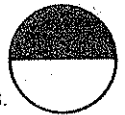

Ref.	Part No.	Qty.	Description
DIPPER ARM AND ANGLING MECHANISM			
1	71-92-320	1	Dipper arm
2	71-11-175	2	Bush-head pivot
3	71-01-083	6	Bush - radius arm and slave link
4	09-01-121	4	Greaser 1/8" BSP - straight
5	71-92-051	1	Angling ram assembly (see page 64)
6	71-92-024	1	Pivot pin - angle ram base
7	71-92-008	1	Pivot pin - angle ram rod
8	71-92-311	1	Radius arm - front
9	71-92-310	1	Radius arm - rear
10	95-01-406	5	Split pin \varnothing 5 x 40
11	71-93-313	1	Hose guide
12	71-93-321	1	Hose cover
13	93-13-055	4	Setscrew M10 x 25
14	92-13-085	1	Bolt M10 x 40
15	92-13-125	1	Bolt M10 x 60
16	91-00-305	6	Internal serrated washer \varnothing 10
17	71-93-014	2	Hose clamp
18	71-93-019	1	Hose clip - angle hoses
19	12-90-295	1	Sticker 'Power arm'
20	12-90-327	1	Sticker - '921'
21	71-92-308	1	Head pivot tube
22	71-92-309	1	Slave link
23	71-92-316	1	Jaw plate
24	04-23-548	1	Spring dowel 5/8" dia x 3" long
25	92-13-185	1	Bolt M10 x 90
26	71-92-321	1	Hose juntion bracket
27	02-11-126	1	Bolt 5/8 UNF x 1 1/2" long
28	71-92-009	1	Pivot pin - slave link
29	02-11-146	1	Bolt 5/8 UNF x 1 3/4" long
30	01-41-006	2	Self locking nut 5/8 UNF
31	71-92-324	1	Hose tray
32	93-13-045	4	Setscrew M10 x 20
33	91-43-005	5	Self locking nut M10

Model

HEDGE FLAIL HEAD

McCONEL

Temeside Works, Ludlow,
Shropshire, SY8 1JL, England.
Telephone: (0584) 3131.
Telex 35313. Facsimile: (0584) 6463.

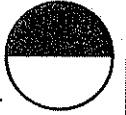

Sheet 1

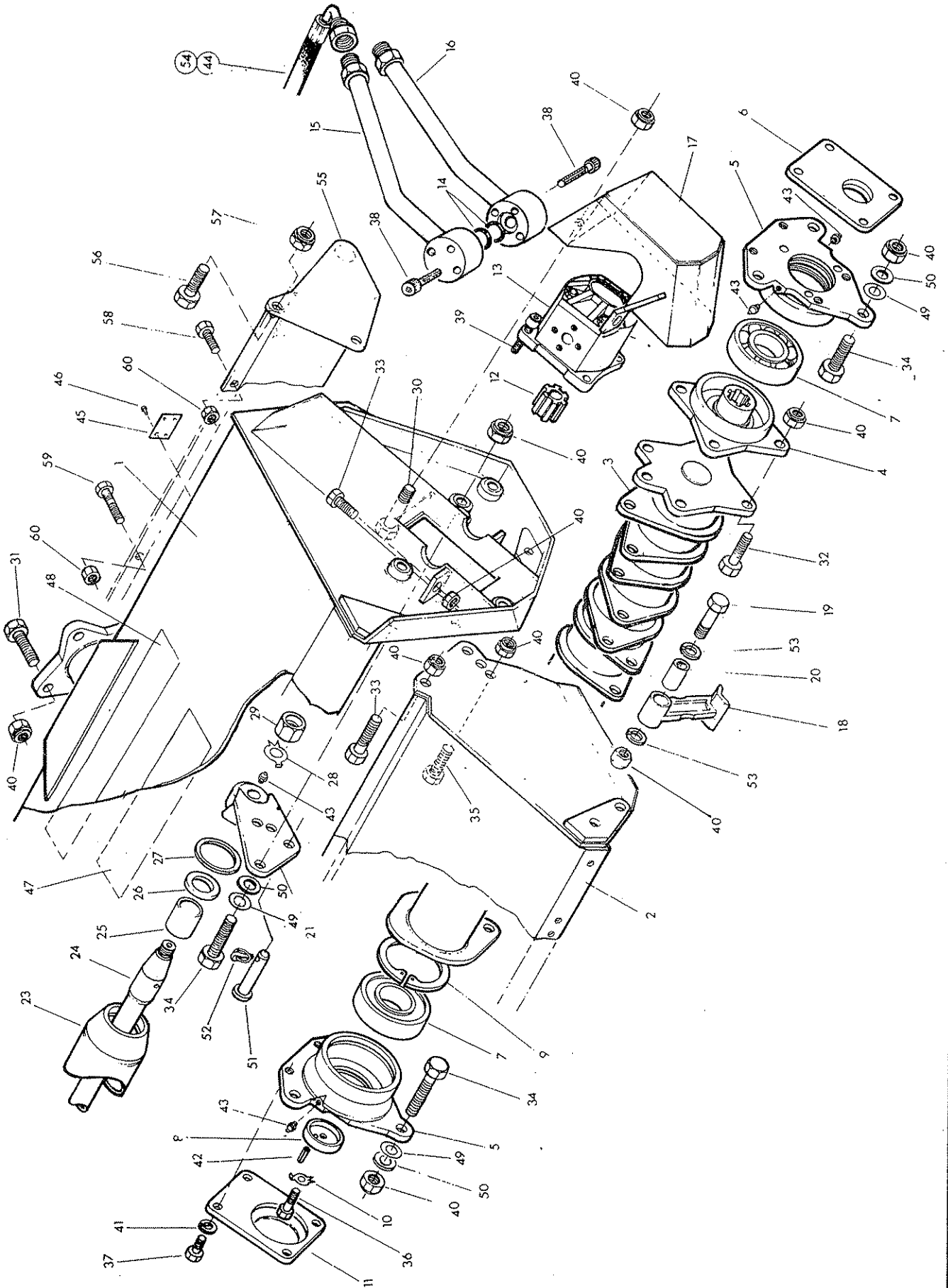

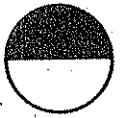

Ref.	Part No.	Qty.	Description
	71-90-365		1.0 METRE HEDGE FLAIL TO CUT ON R.HAND SIDE OF TRACTOR WITH MOTOR OUTBOARD
1	71-90-343	1	Flail casing
2	71-90-347	1	Front hood
3	71-90-360	1	Rotor
4	71-90-280	1	Rotor hub
5	71-90-261	2	Bearing housing
6	71-90-293	1	Motor spacer plate
7	06-00-018	2	Bearing
8	71-90-025	1	Clamp washer
9	71-90-022	1	Internal circlip \emptyset 120
10	71-90-024	1	Tab washer \emptyset 12
11	71-90-292	1	Cover plate
12	71-90-009	1	Drive coupling
13	83-01-263	1	Hydraulic motor
14	86-00-121	2	'O' Ring
15	71-90-358	1	Motor pipe upper
16	71-90-359	1	Motor pipe lower
17	71-90-282	1	Motor cover
18	73-14-366	20	Hedge flail F10H
19	73-14-201	20	Special bolt
20	73-14-223	20	Pivot bush
21	71-90-306	1	Roller bracket L.Hand
22	71-90-305	1	Roller bracket R.Hand-not illus
23	71-90-351	1	Roller
24	71-90-352	1	Roller tie rod
25	72-13-023	2	Bush
26	71-90-026	2	Thrust washer
27	71-90-028	2	Felt seal
28	71-90-023	2	Tab washer \emptyset 20
29	71-14-176	2	Special nut M 20
30	02-11-266	1	Bolt 5/8 UNF x 3 $\frac{1}{4}$ " long

Model

HEDGE FLAIL HEAD

McCOMEL

Temeside Works, Ludlow,
Shropshire, SY8 1JL, England.
Telephone: (0584) 3131.
Telex 35313. Facsimile: (0584) 6463.

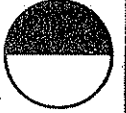

Sheet 2

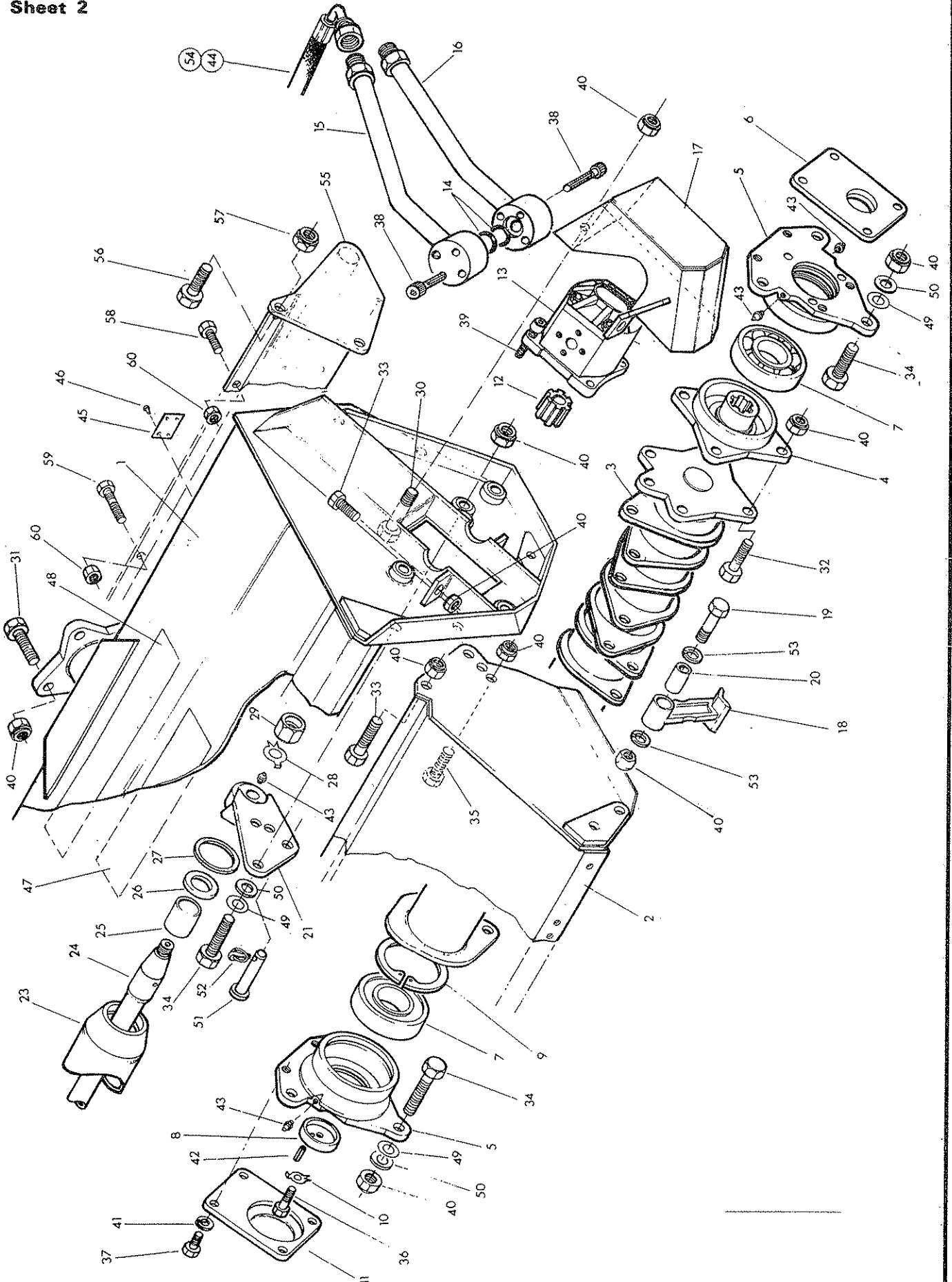

Model

McCONNEL

Temeside Works, Ludlow,
Shropshire, SY8 1JL, England.
Telephone: (0584) 3131.
Telex 35313. Facsimile: (0584) 6463.

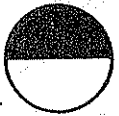

Ref.	Part No.	Qty.	Description
	71-90-365		1.0 METRE HEDGE FLAIL TO CUT ON R.HAND SIDE OF TRACTOR WITH MOTOR OUTBOARD - continued
31	02-11-186	4	Bolt 5/8 UNF x 2 1/2" long
32	03-11-146	4	Setscrew 5/8 UNF x 1 3/4" long
33	03-11-126	4	Setscrew 5/8 UNF x 1 1/2" long
34	03-11-166	8	Setscrew 5/8 UNF x 2" long
35	03-11-106	2	Setscrew 5/8 UNF x 1 1/4" long
36	93-13-076	1	Setscrew M12 x 35
37	83-13-045	4	Setscrew M10 x 20
38	93-00-014	6	Capscrew 'wedglok' M10 x 60
39	93-00-136	4	Capscrew 'wedglok' M10 x 45
40	01-41-006	43	Self locking nut 5/8 UNF
41	91-00-205	4	Spring washer Ø 10
42	04-21-608	1	Spring dowel 3/16" dia x 1/2" long
43	09-01-121	6	Greaser
44	85-01-167	2	Hose 1 1/16" JIC SF-90 ⁰ F x 29" long for outboard motors
45	73-14-087	1	Serial No. plate
46	71-03-230	4	Pop rivet 1/8" dia
47	12-90-297	1	Flail head instruction STicker
48	12-90-255	1	'McConnell' sticker
49	81-21-043	as reqd	Shim 0.15"
50	81-21-044	as reqd	Shim 0.25"
51	71-90-032	2	Pin
52	04-31-213	2	Linch pin
53	01-00-206	40	Spring washer 5/8 dia
	86-99-166		<u>SEAL KIT FOR HYDRAULIC MOTOR</u> Contains all seals plus tab washer and nut

OPTIONAL EXTRAS

	71-90-362	1	Rear hood kit for flail heads with downward cutting flails - containing:-
55	71-90-253	1	Hood
56	03-11-106	4	Bolt 5/8 UNF x 1 1/4"
57	01-41-006	4	Self locking nut 5/8 UNF
58	93-13-045	1	Setscrew M10 x 20
59	93-13-055	2	Set screw M10 x 25
60	91-43-005	3	Self locking nut M10

Model

GRASS FLAIL HEAD

MCCONEL

Temeside Works, Ludlow,
Shropshire, SY8 1JL, England.
Telephone: (0584) 3131.
Telex 35313. Facsimile: (0584) 6463.

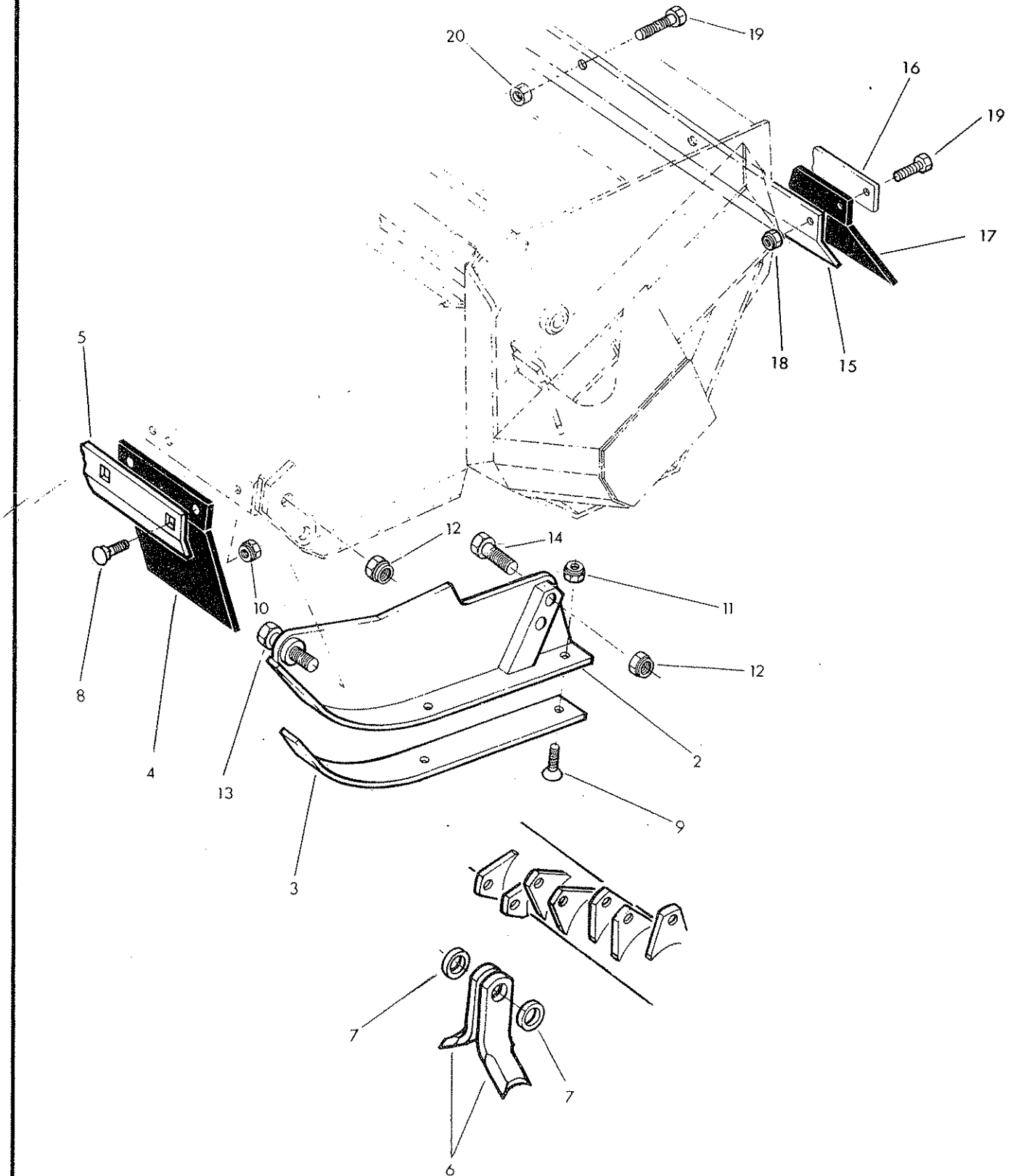
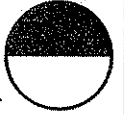



Ref.	Part No.	Qty.	Description
	71-90-366		1.0 METRE GRASS FLAIL TO CUT ON R.HAND SIDE OF TRACTOR WITH MOTOR OUTBOARD

Spare parts lists and seal kits are identical with their hedge flail counterparts on the previous page with the following exceptions.

Item 18 part No 73-14-366, 20 off, hedge flail is deleted

The following items are added

1	71-90-300	1	Skid-R.Hand-not illustrated
2	71-90-301	1	Skid L-hand
3	73-14-323	2	Replaceable skid
4	71-90-035	7	Flap
5	71-90-350	1	Flap clamp strip
6	71-90-299	40	Grass flail
7	71-90-010	40	Flail spacer
8	92-93-054	14	Cup-square bolt M8 x 25
9	93-33-065	6	Setscrew c/sunk M10 x 30
10	91-43-004	14	Self locking nut M8
12	01-41-006	4	Self locking nut 5/8 UNF
13	03-11-146	2	Setscrew 5/8 UNF x 1 $\frac{3}{4}$ " long
14	03-11-186	2	Setscrew 5/8 UNF x 2 $\frac{1}{4}$ " long

Spares Note.

The items listed above can be ordered as a hedge to grass conversion kit under part No. 71-90-364

In addition a grass flail spares handy pak is available-part No. 71-90-259 which comprises

71-90-299	10off	Grass flail
71-90-010	2off	Spacer
71-36-133	loff	Pivot bush
73-14-222	loff	Special flail bolt
01-41-006	loff	Self locking nut 5/8 UNF

OPTIONAL EXTRAS

71-90-363	1	Rear flap kit - to provide additional guarding for flail heads with upward cutting flails suitable for grass or hedge-containing:-	
15	71-90-356	1	Mounting strip
16	71-90-357	1	Clamp strip
17	71-90-355	1	Flap
18	93-13-045	1	Setscrew M10 x 20
19	93-13-055	11	Setscrew M10 x 25
20	91-43-005	12	Self locking nut M10

Model

HYDRAULIC INSTALLATION

MCCONEL

Temeside Works, Ludlow,
Shropshire, SY8 1JL, England.
Telephone: (0584) 3131.
Telex 35313. Facsimile: (0584) 6463.

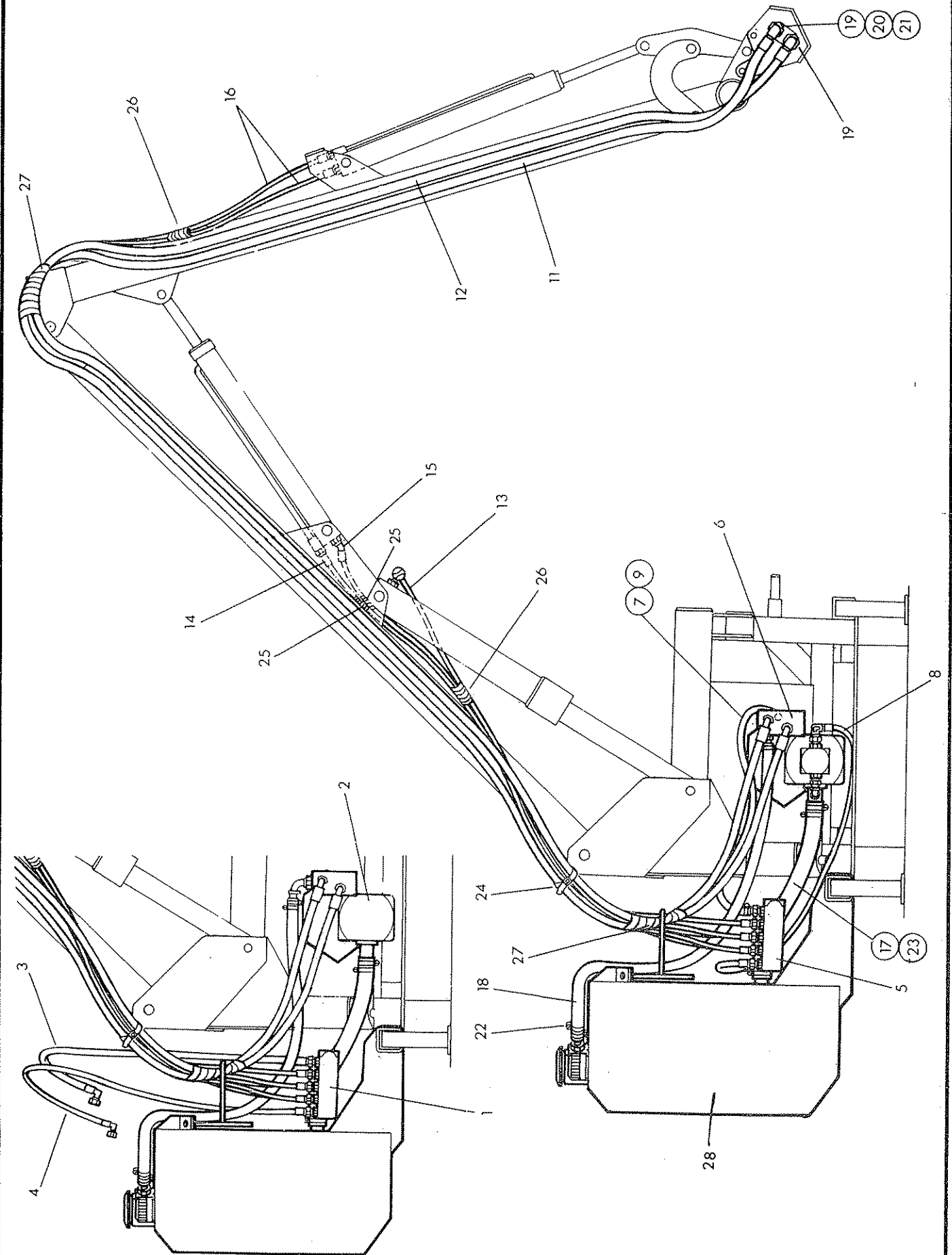
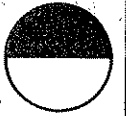

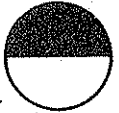

Ref.	Part No.	Qty.	Description
			HYDRAULIC INSTALLATION PA 921 SEMI INDEPENDENT MODEL ONLY
1	81-30-382	1	Control valve assembly (see pages 47-50)
2	80-13-086	1	Gearbox /pump/valve assy (see page 51)
3	85-32-019	1	Hose 7/8 JIC -SF- 90° x 80" Long Return Tractor
4	85-31-808	1	Hose 3/4 JIC -SF- 90° x 30 Long Supply - tractor
			HYDRAULIC INSTALLATION PA 921 FULLY INDEPENDENT MODEL ONLY
5	81-30-381		Control valve assembly (see pages 47-50)
6	80-13-085	1	Gearbox/pump/valve assy (See page 53)
7	85-01-090	1	Hose 5/8" bore x 44" long. Return to rotor on/off valve
8	85-31-068	1	Hose 3/8" JIC SF-90° F x 31" long. Supply from pump
9	09-04-204	2	Hose clip 5/8" bore hose
The remaining items are common to all PA921			
10	71-09-319	1	Control mounting assembly -not illus (see page 61)
11	85-01-177	1	Hose JIC 1 1/16" SF x 90° F Swept 205" long motor supply
12	85-01-178	1	Hose JIC 1 1/16" SF x 1 3/16" 90° F Swept 205" long motor return
13	85-35-107	1	Hose 1/2" JIC SF - 90° F x 60" long. Lift
14	85-15-047	1	Hose 1/2" JIC SF-SF x 64" long. Reach gland
15	85-45-027	1	Hose 1/2" JICSF-135° x 64" long. Reach base
16	85-15-057	2	Hose 1/2" JIC SF x SF x 144" long. Angle
17	85-01-157	1	Hose 1/2" bore x 19" long. Suction from tank
18	85-00-845	1	Hose low pressure 1" bore x 45" long rotor valve tank
19	85-81-160	2	Elbow 1 1/16 JIC 90° Swept MF
20	85-81-273	1	Adaptor 1 1/16" JIC
21	86-50-106	1	Bonded seal 3/4" BSP
22	09-04-106	4	Hose clip - 1" bore hose
23	09-04-107	4	Hose clip - 1 1/4" bore hose
24	71-06-187	1	Hose tie
25	71-92-044	2	Hose armour 1/2" dia x 50mm long
26	72-35-090	2	Hose armour coil 3/8" dia x 50mm long
27	71-36-143	2	Hose armour coil 1" x 80m long
28	71-95-316	1	Tank assembly (See page 59)

Model

CONTROL VALVE

McCONEL

Temeside Works, Ludlow,
Shropshire, SY8 1JL, England.
Telephone: (0584) 3131.
Telex 35313. Facsimile: (0584) 6463.

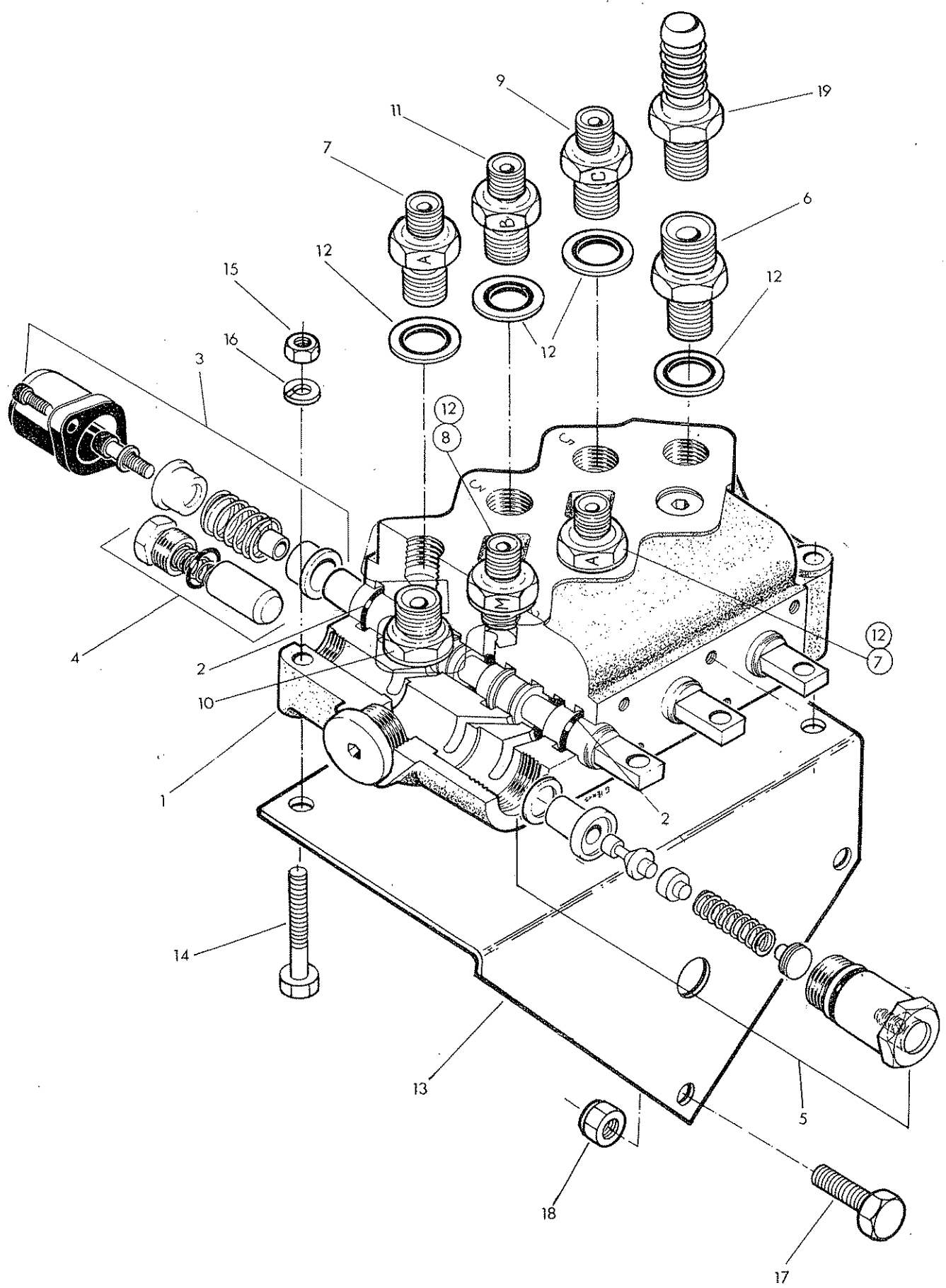
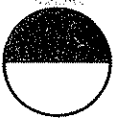

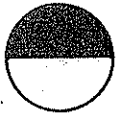

Ref.	Part No.	Qty.	Description
	81-30-381		HYDRAULIC CONTROL ASSEMBLY FOR PA 921 FULLY INDEPENDENT MODEL
*	81-30-342	1	Valve c/w connectors
1	81-30-252	1	Valve block c/w spools 'O' rings
2	86-00-112	6	'O' ring
3	81-30-134	3	Centering spring assembly
4	81-30-022	1	Non-return valve assembly
5	G381-2537	1	Relief valve assembly
6	81-25-008	1	Return connection 3/8" Bore
7	81-30-132	2	Restrictor union A JIC
8	81-30-131	1	Restrictor union 'M' JIC
9	81-30-162	1	Restrictor union 'C' JIC
10	85-81-170	1	Union 3/8 BSP x $\frac{3}{8}$ JIC M-M
11	81-30-161	1	Restrictor union 'B' JIC
12	86-50-103	7	Bonded seal 3/8 BSP
13	71-92-025	1	Valve mounting plate
14	92-13-124	3	Bolt M8 x 60
15	91-13-004	3	Nut M8
16	91-00-204	3	Spring washer
17	93-13-055	2	Setscrew M10V25
18	91-43-005	2	Self locking nut M10
	86-00-163		Seal Kit
	81-30-382		HYDRAULIC CONTROL ASSEMBLY FOR PA921 SEMI INDEPENDENT MODEL

The parts list is identical to above with the following exceptions

*becomes

	81-30-337	1	Valve c/w connections
Less item 6 Plus item-			
19	85-81-222	1	Union 3/8 BSP x 7/8 JIC M-M
			Lever control-See following page

Model

**CONTROL HANDLE ASSY
& CABLES**

MCCONEL

Temeside Works, Ludlow,
Shropshire, SY8 1JL, England.
Telephone: (0584) 3131.
Telex 35313. Facsimile: (0584) 6463.

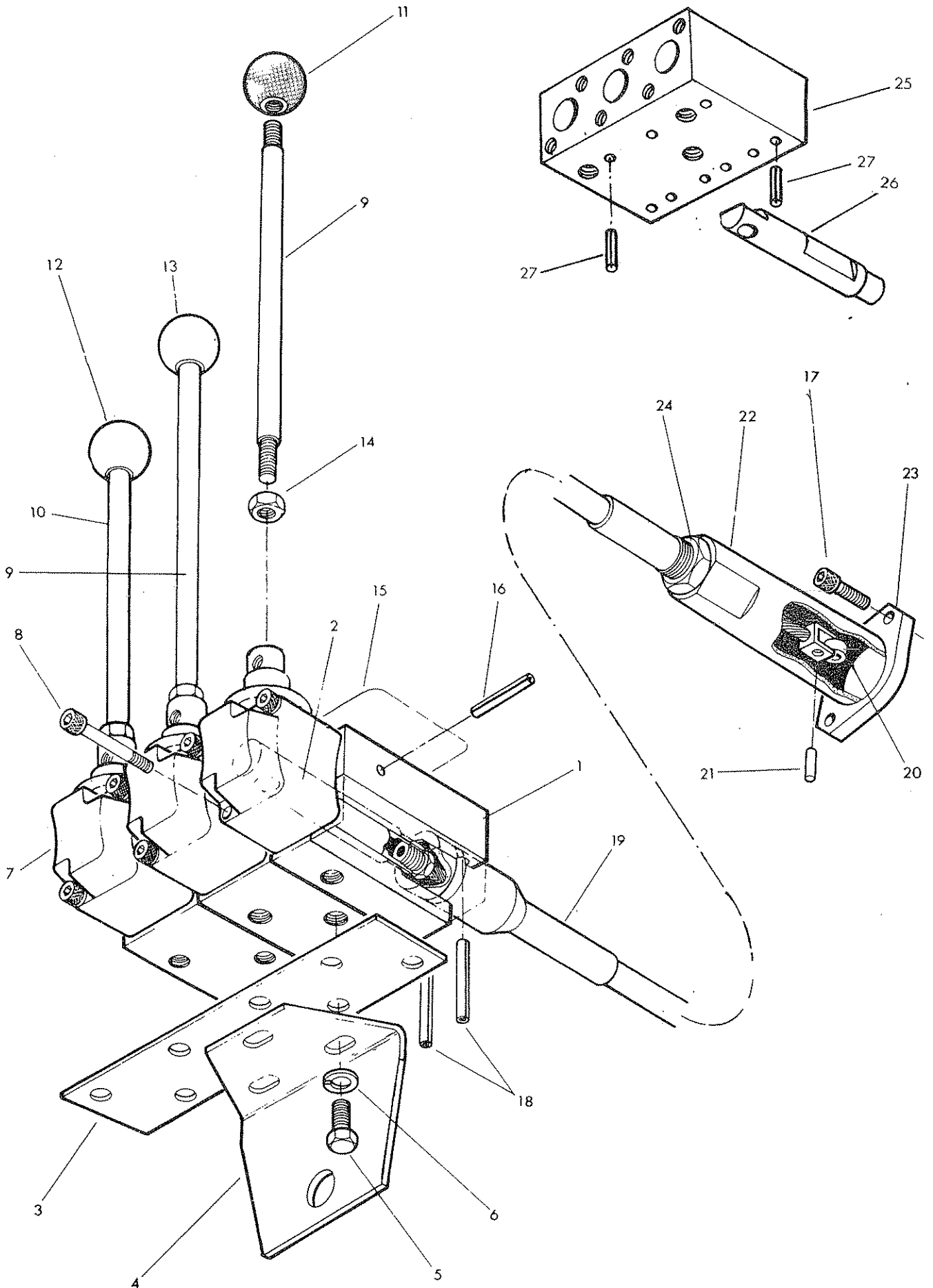
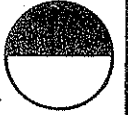



Ref.	Part No.	Qty.	Description
	81-30-381		HYDRAULIC CONTROL ASSY FOR PA 921 FULLY INDEPENDENT MODEL continued
	81-30-382		HYDRAULIC CONTROL ASSY FOR PA 921 SEMI INDEPENDENT MODEL ONLY-continued
1	81-30-052	3	Control block
2	81-30-053	3	Control block spindle
3	71-14-071	1	Control block mounting base
4	80-17-006	1	Mounting bracket
5	93-13-034	6	Setscrew M8 x 16
6	01-00-102	6	Thin washer 5/16" diameter
7	81-30-065	3	Lever pivot box assembly
8	92-43-072	6	Socket headed capscrew M5 x 35
9	71-09-131	2	Lever handle long
10	71-09-132	1	Lever handle short
11	09-03-112	1	Lever knob-Reach (Red)
12	09-03-113	1	Lever knob-Angle (Green)
13	09-03-114	1	Lever knob-Lift (Yellow)
14	91-13-004	3	Hexagon nut M8
15	81-30-093	1	Operating instruction label
16	04-25-540	3	Spring dowel Ø 5 x 40
17	93-43-022	6	Socket headed capscrew M5 x 12
18	04-25-540	3	Spring dowel Ø 5 x 40
* 19	81-25-046	3	Cable & spacer and pin, sleeve, flange etc.
20	71-15-158	1	Spool eye bush
21	71-15-160	1	Pin
22	71-15-162	1	Sleeve
23	81-25-050	1	Flange
24	01-31-006	1	Thin locknut 5/8 UNF

* An alternative cable assembly may be fitted depending on supply availability.

The complete assembly is interchangeable and thus retains the same assembly Part Number i.e. 81-25-046.

Individual cable components are not interchangeable thus before ordering spares the cable must be correctly identified.

The cable listed above is manufactured by "BOWDEN" and is BLACK

The alternative cable manufactured by "TELEFLEX MORSE" is RED and consists of:

19	81-25-046	1	Cable assembly c/w sleeve, flange etc.
20	81-25-049	1	Cable sleeve
21	81-25-050	1	Flange
22	81-25-051	1	Pin
23	91-00-016	1	Thin locknut Ø16 x 1.5 pitch
24	80-17-004	1	Spool eye bush

• Spares Note.

Some machines may be supplied with an alternative "single block" control unit.

Item 1 is replaced by Item 25 Part No. 81 30 391 1 off

Item 2 is replaced by Item 26 Part No. 81 30 144 3 off

Items 16 and 18 are replaced by item 27 Part No. 04 25 525 9 off

Item 5 now becomes 3 off and item 6 becomes 3 off.

Model

**GEARBOX, PUMP, ROTOR
RELIEF VALVE ASSY.**

McCOMEL

Temeside Works, Ludlow,
Shropshire, SY8 1JL, England.
Telephone: (0584) 3131.
Telex 35313. Facsimile: (0584) 6463.

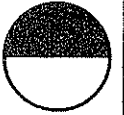

Si model only

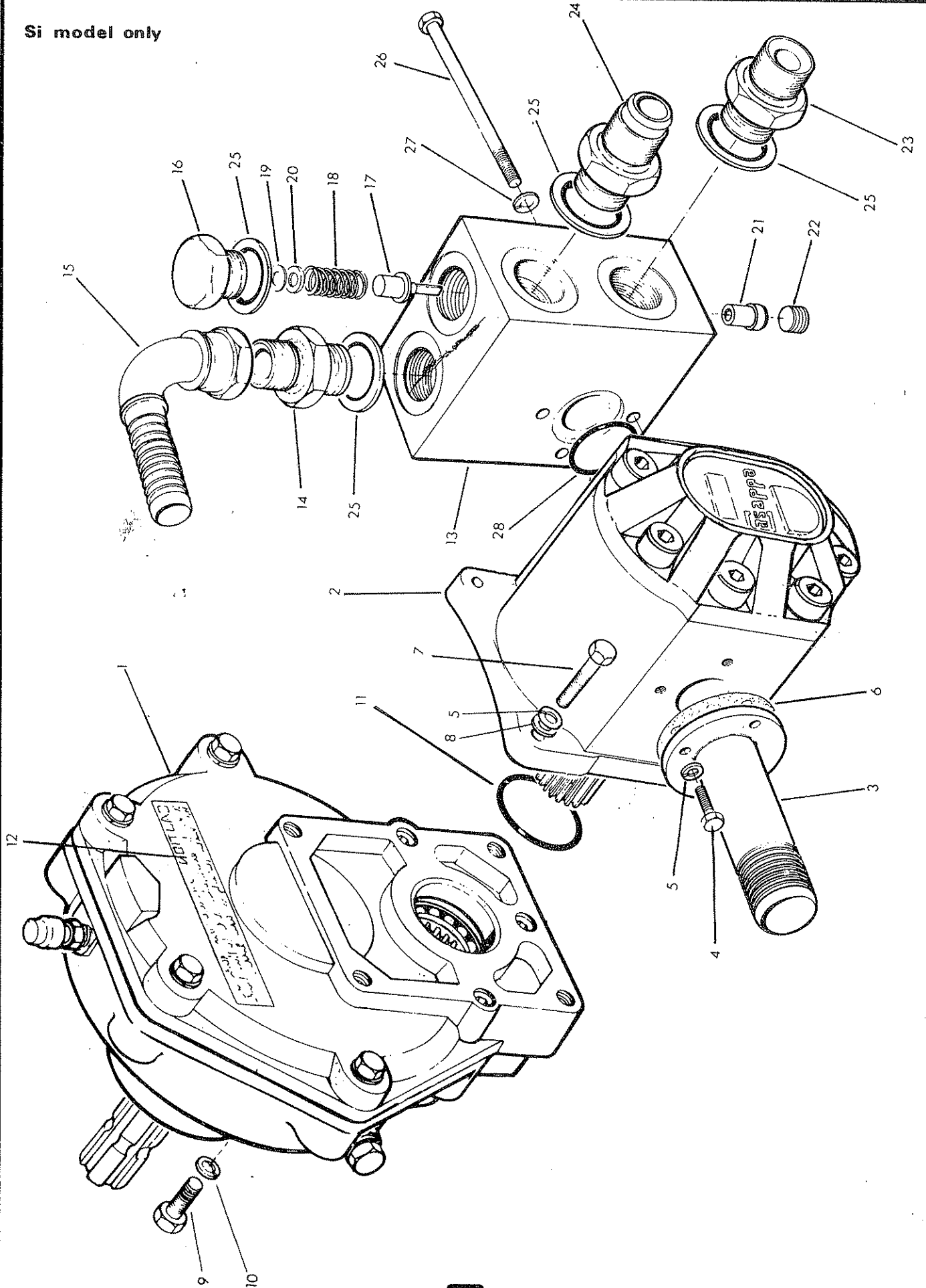

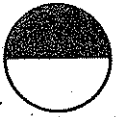

Ref.	Part No.	Qty.	Description
	80-13-086		Gearbox/pump/rotor relief valve
1	80-13-360	1	Gearbox (see page 57)
2	82-01-463	1	Pump
3	71-23-052	1	Flanged union
4	93-13-044	4	Set Screw M8 x 20
5	91-00-204	8	Spring washer \emptyset 8
6	80-13-023	1	Gasket
7	92-13-094	4	Bolt M8 x 45
8	91-00-104	4	Plain washer \emptyset 8
9	93-13-056	4	Setscrew M12 x 25
10	91-00-206	4	Spring washer \emptyset 12
11	86-00-523	1	'O' ring
12	80-13-081	1	Gearbox label
	81-25-094	1	Rotor relief valve compr:-
13	81-25-321	1	Valve block
14	80-02-086	1	Union 1" BSP- $\frac{3}{4}$ " BSP M-M
15	71-14-005	1	90° Swept elbow 1" BSP
16	81-25-088	1	Relief valve cap
17	81-25-083	1	Needle/spring register
18	81-10-086	1	Spring
19	60-01-232	as reqd	Shim
20	01-00-102	" "	Shim
21	81-25-084	1	Bush
22	85-82-043	1	Taper plug 3/8 BSPT
23	85-81-274	1	$\frac{3}{4}$ BSP x 1 3/16" JIC adaptor
24	85-81-167	1	$\frac{3}{4}$ BSP x 1 1/16 JIC adaptor
25	86-50-106	4	Bonded seal 3/4 BSP
26	92-13-124	3	Bolt M8 x 60
27	91-00-204	3	Spring washer \emptyset 8
28	86-00-119	1	'O' ring

* Assembly note

Bush secured in position using "loctite 115"

86-99-215

Seal Kit

Model

**GEARBOX, PUMP, ROTOR.
CONTROL VALVE ASSY.**

MCCONEL

Temeside Works, Ludlow,
Shropshire, SY8 1JL, England.
Telephone: (0584) 3131.
Telex 35313. Facsimile: (0584) 6463.

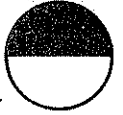

Ti model only

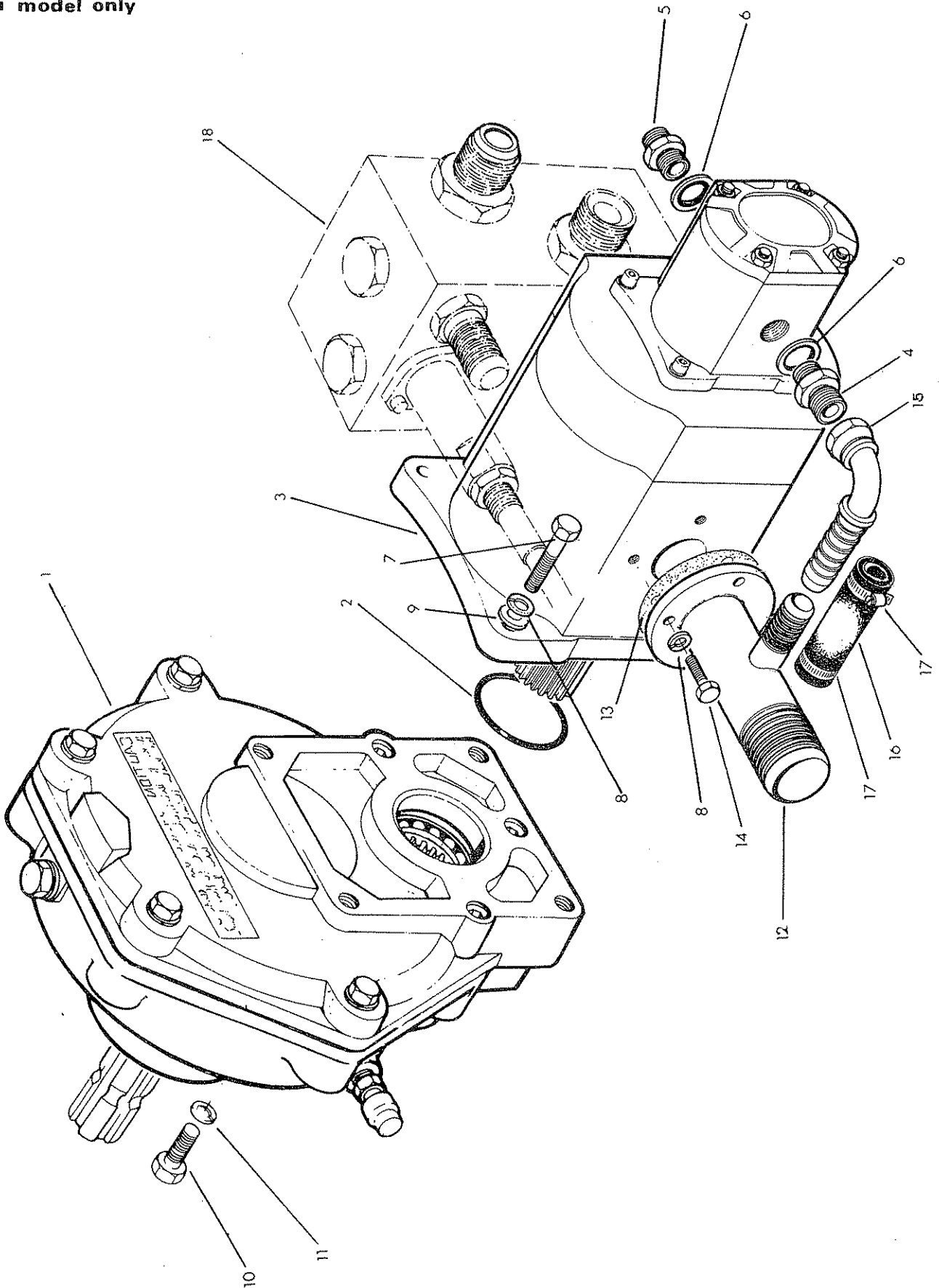

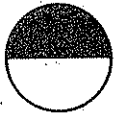

Ref.	Part No.	Qty.	Description
	80-13-085		PUMP & GEARBOX ASSY
	80-13-368		GEAR BOX AND PUMP
1	80-13-360	1	Gearbox 4.94.1 (see page 57)
2	86-00-523	1	'O' ring
3	82-01-466	1	Tandem pump CPL 33/5.7
4	85-81-180	1	Union $\frac{1}{2}$ BSP x $\frac{5}{8}$ BSP M-M
5	81-20-003	1	Union $\frac{3}{4}$ JIC x $\frac{1}{2}$ BSP M-M
6	86-50-104	2	Bonded seal $\frac{1}{2}$ BSP
7	92-13-094	4	Bolt M8 x 45
8	91-00-204	8	Spring washer \emptyset 8
9	91-00-104	4	Plain washer
10	93-13-056	4	Set screw M12 x 25
11	91-00-206	4	Spring washer \emptyset 12
12	71-14-308	1	Junction union c/w gasket
13	80-13-023	1	Gasket
14	93-13-044	4	Setscrew M8 x 20
15	85-81-173	1	Swept elbow connection
16	85-01-103	1	Connecting hose
17	09-04-204	2	Hose clip $\frac{5}{8}$ bore hose
18	81-25-351	1	Rotor control valve (see page 55)

Model

ROTOR CONTROL VALVE

McGONEL

Temeside Works, Ludlow,
Shropshire, SY8 1JL, England.
Telephone: (0584) 3131.
Telex 35313. Facsimile: (0584) 6463.

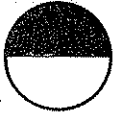

Ti model only

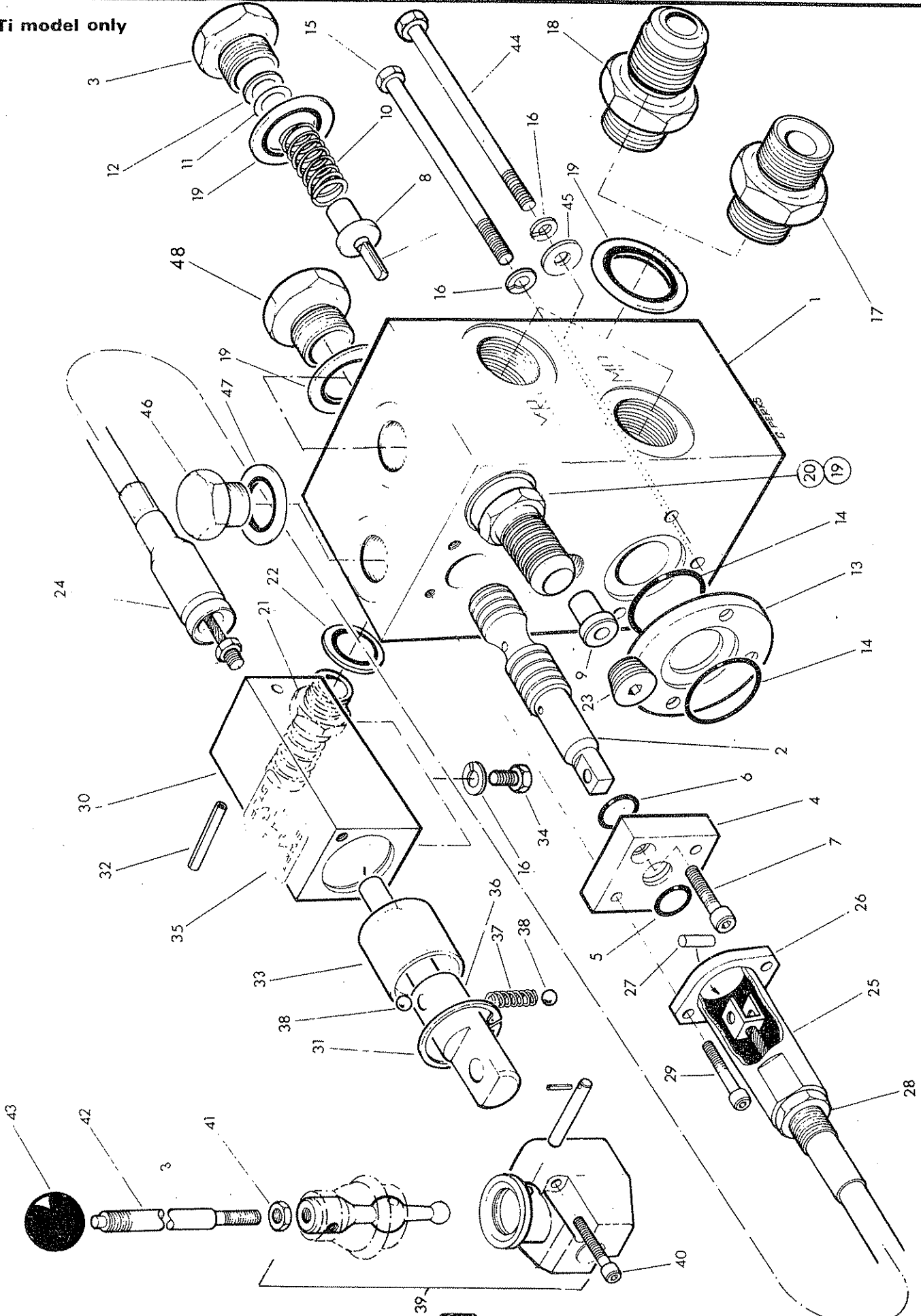

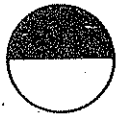

Ref.	Part No.	Qty.	Description
	81-25-351		ROTOR CONTROL VALVE
1	81-25-067	1	.Valve body c/w spool (not supplied separately)
2		1	Spool (reference only)
3	81-25-087	4	.Spool or Relief valve cap
4	81-25-039	1	.Control plate c/w 'O' rings
5	86-00-502	1	.. 'O' ring
6	86-00-503	1	.. 'O' ring
7	93-43-023	2	.Capscrew M6 x 12
8	81-25-083	1	.Needle/spring register
9	81-25-084	1	.Drill bush
10	81-25-086	1	.Relief valve spring
11	60-01-232	as reqd.	0.4 Shim washer
12	01-00-102	" "	.5/16" dia bright washer
13	81-25-045	1	.Spacer
14	86-00-119	2	.. 'O' ring
15	92-13-184	1	.Bolt M8 x 90
16	91-00-204	5	.Spring washer Ø 8
17	85-81-274	1	.Union ½" BSP x 1 3/16" JIC M-N
18	85-81-167	1	Union 1 1/16" JIC - ½" BSP M
19	86-50-106	7	.Bonded seal ¾" BSP
20	81-27-134	1	.Return connection ¾" BSP
21	81-25-008	1	.Low pressure connection
22	86-50-103	1	.Bonded seal 3/8" BSP
23	85-82-044	1	.Taper plug ½" BSPT
24	81-25-046	1	.Cable assembly c/w sleeve, flange, etc
25	81-25-162	1	..Sleeve
26	81-25-050	1	..Flange
27	81-25-160	1	..Pin
28	91-00-006	1	..Thin locknut 5/8 UNF
29	93-43-022	2	.Capscrew M5 x 12
30	71-14-069	1	.Control block c/w spring dowel and circlip
31	04-11-118	1	..Internal circlip
32	04-25-540	1	..Spring dowel Ø 5 x 40
33	71-14-067	1	.Detent cage
34	93-13-034	2	.Setscrew M8 x 16
35	71-14-073	1	.Instruction label
36	71-14-070	1	.Spindle
37	71-14-068	1	.Spring
38	09-05-108	2	.Steel ball ½" diameter
39	81-30-065	1	.Lever pivot box assembly comprising:-
40	93-43-072	2	.Capscrew M5 x 35
41	91-13-004	1	.Thin hexagon nut M8
42	71-14-072	1	.Lever handle
43	09-03-121	1	.Knob -black
44	92-13-204	2	.Bolt M8 x 100
45	85-21-068	2	.Special washer
46	81-03-001	1	½" BSP Plug
47	86-50-104	1	Bonded Seal ½" BSP
48	81-25-031	2	¾" BSP Hex Plug

86-99-196 SEAL KIT

An alternative cable assembly may be fitted depending on supply availability. The complete assembly is interchangeable and thus retains the same assembly Part Number i.e. 81-25-046
Individual cable components are not interchangeable thus before ordering spares the cable must be correctly identified.
The cable listed above is manufactured by "BOWDEN" and is BLACK.

The alternative cable manufactured by "TELEFLEX MORSE" is RED and consists of

81-25-046	1	Cable assembly c/w sleeve, flange etc
81-25-049	1	Cable sleeve
81-25-050	1	Flange
81-25-051	1	Pin
91-00-016	1	Thin locknut Ø 16 x 1.5 pitch

With 81-25-046 a spool eye bush is supplied. This item is discarded when the cable is used with the rotor control valve.

Model

GEARBOX

McCONEL

Temeside Works, Ludlow,
Shropshire, SY8 1JL, England.
Telephone: (0584) 3131.
Telex 35313. Facsimile: (0584) 6463.

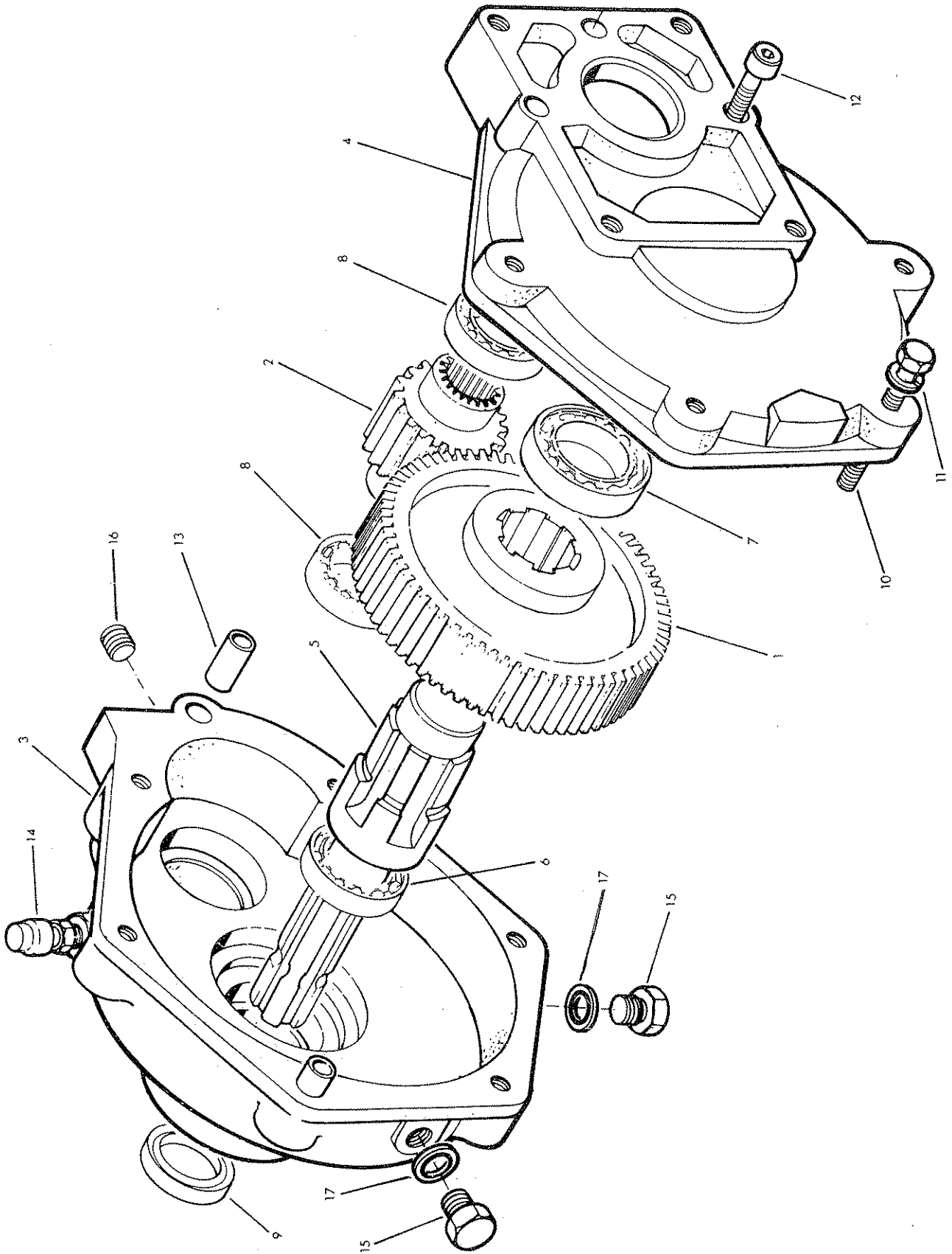
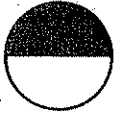

Model

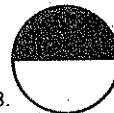
McCOMELTemeside Works, Ludlow,
Shropshire, SY8 1JL, England.
Telephone: (0584) 3131.
Telex 35313. Facsimile: (0584) 6463.

Ref.	Part No.	Qty.	Description
	80-13-360		GEARBOX ASSEMBLY
1	80-13-384	1	Gear 78 teeth
2	80-13-385	1	Pinion 17 teeth
3	80-13-370	1	Gearbox casing - input
4	80-13-371	1	Gearbox lid - output
5	80-13-374	1	Input Shaft 1 3/8" dia. x 6 spline
6	06-00-063	1	Bearing
7	06-00-064	1	Bearing
8	06-00-065	2	Bearing
9	86-29-151	1	Shaft seal 2 1/8" x 1 3/8" x 1/2"
10	92-13-064	4	Bolt M8 x 30
11	91-00-204	4	Spring Washer Ø 8
12	93-43-074	3	Capscrew socket headed M8 x 35
13	80-13-375	2	Sleeve dowel
14	80-13-376	1	Breather
15	85-81-133	2	Plug-level and drain 1/4BSP
16	85-82-042	1	Taper plug 1/4 BSPT
17	86-50-102	2	Bonded seal 1/4" BSP

Model

**HYDRAULIC TANK &
COVER PLATE**

MCCONEL

Temeside Works, Ludlow,
Shropshire, SY8 1JL, England.
Telephone: (0584) 3131.
Telex 35313. Facsimile: (0584) 6463.

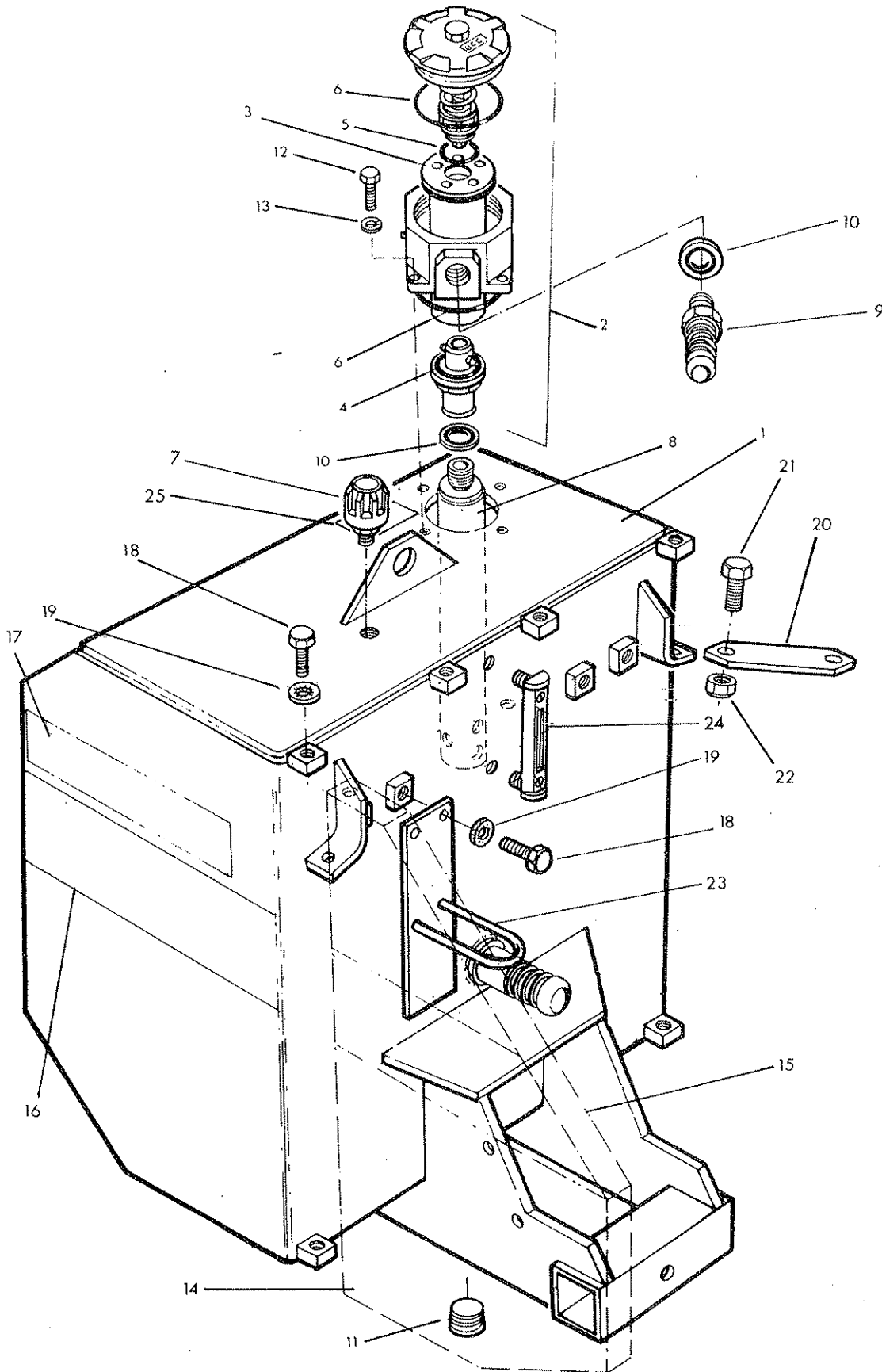

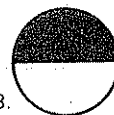

Ref.	Part No.	Qty.	Description
			HYDRAULIC TANK & COVER PLATE (for machines after July 1988)
	71-95-216		Oil tank assembly compr:-
* 1	71-95-315	1	Oil tank
2	84-01-053	1	Return filter assy. inc. element and 'O' rings
3	84-01-054	1	Element
4	85-00-131	1	'O' ring
5	86-00-126	1	'O' ring
6	87-00-220	2	'O' ring
7	84-01-055	1	Breather assembly
8	71-92-019	1	Return pipe
9	85-81-245	1	Return connection
10	86-50-106	2	Bonded seal 3/4" BSP
11	85-81-203	1	Drain plug 1" BSP
12	93-13-054	4	Setscrew M8 x 25
13	91-00-204	4	Spring washer Ø8
14	71-92-330	1	Cover plate
15	12-90-283	1	'Stripe'
16	12-90-288	1	'Tank stripe - PA92'
17	12-90-253	1	Sticker 'McConnel'
18	93-13-045	4	Setscrew M10 x 20
19	91-00-305	4	Internal serrated washer Ø 10
20	71-92-029	1	Tank strap
21	93-13-055	2	Setscrew M12 x 25
22	91-43-006	2	Self locking nut Ø 12
23	71-92-028	1	Hose guide
24	84-01-048	1	Oil level guage
25	12-90-023	1	Label 'OIL FILTER'

* Spares note

For machines prior to July 1988 a new tank must be ordered
c/w oil level guage and breather.

Model

**CONTROL MOUNTING
ASSY**

McCONEL

Temeside Works, Ludlow,
Shropshire, SY8 1JL, England.
Telephone: (0584) 3131.
Telex 35313. Facsimile: (0584) 6463.

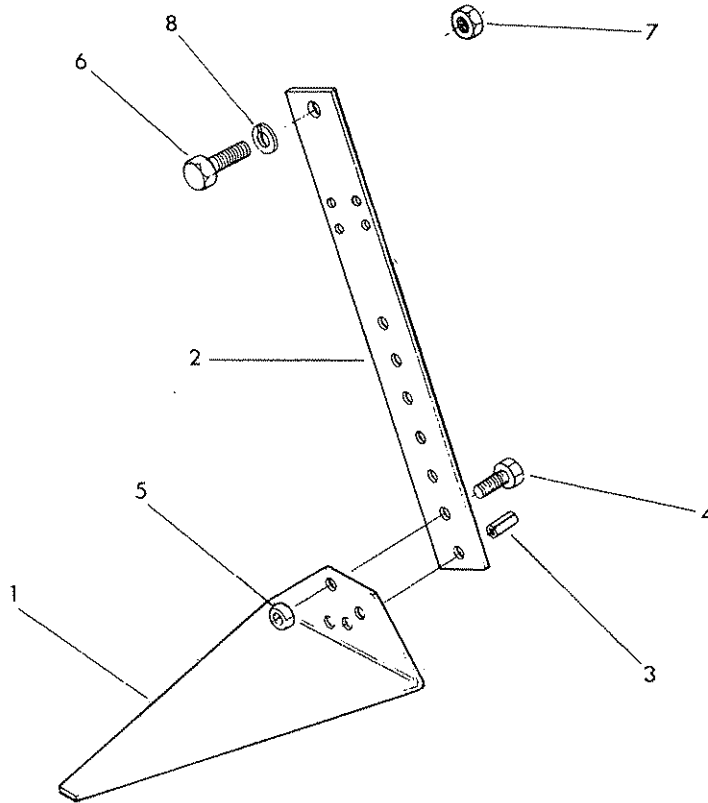
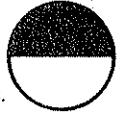

Ref.	Part No.	Qty.	Description
	71-09-319		CONTROL MOUNTING ASSEMBLY
1	71-09-320	1	Sandwich plate
2	71-09-146	1	Pillar including spring dowel
3	04-22-816	1	Spring dowel
4	93-13-066	1	Setscrew M12 x 30
5	91-13-006	1	Nut M12
6	93-11-086	1	Setscrew 5/8 UNF x 1" long
7	01-11-006	1	Nut 5/8 UNF
8	01-00-206	1	Spring washer 5/8" dia

Model

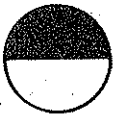
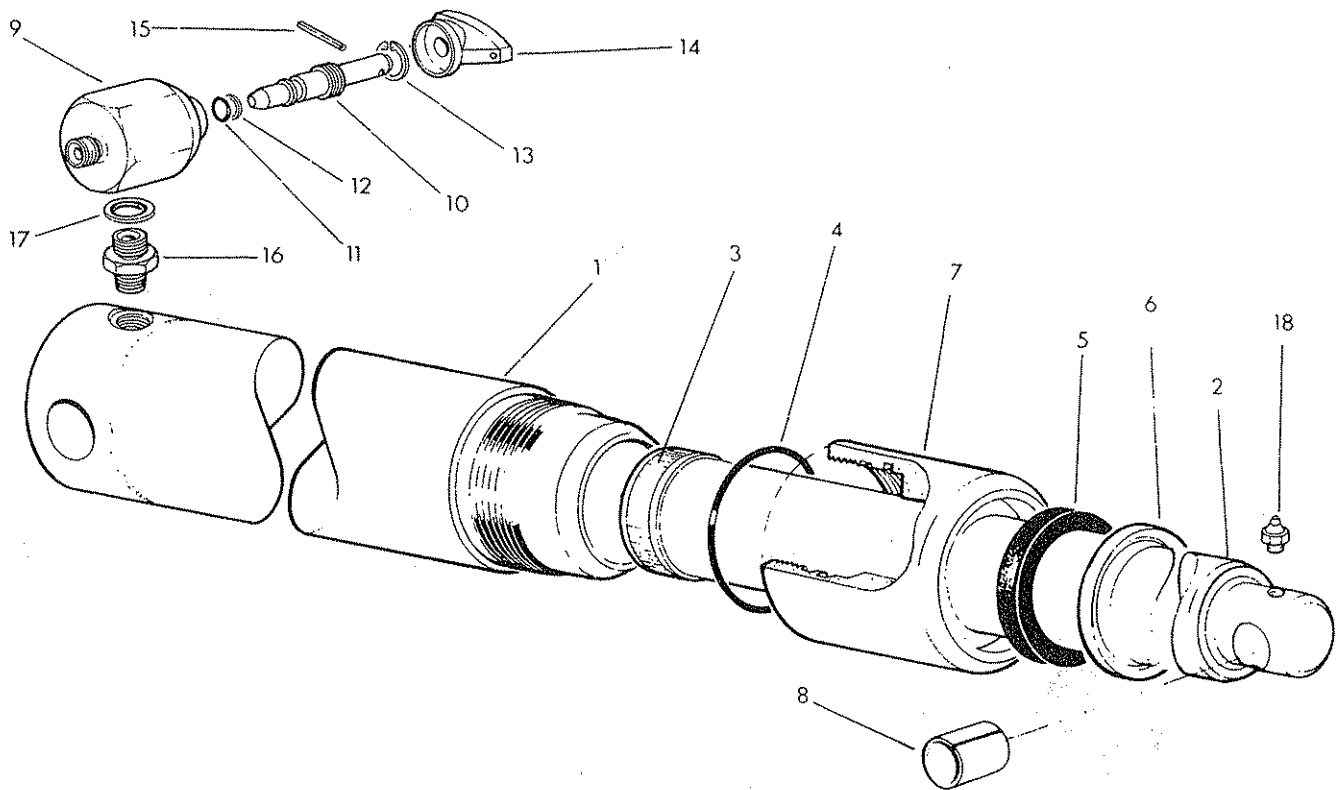
McCONELTemeside Works, Ludlow,
Shropshire, SY8 1JL, England.
Telephone: (0584) 3131.
Telex 35313. Facsimile: (0584) 6463.**LIFT RAM**

Ref.	Part No.	Qty.	Description
	71-92-049		LIFT RAM ASSEMBLY
	71-92-332	1	Ram assembly including:-
1	71-92-333	1	Ram cylinder
2	71-92-334	1	Ram rod
3	86-29-174	1	Wear ring
4	86-00-435	1	'O' ring
5	86-29-172	1	Rod seal
6	86-29-173	1	Rod wiper
* 7	71-92-033	1	Cylinder head
8	71-05-050	1	Rod bush
● 9	71-92-052	1	Lock tap including:-
9	71-92-341	1	Tap body
10	71-35-006	1	Tap spindle
11	86-00-107	1	'O' ring
12	86-09-107	1	Anti extrusion ring
13	04-16-110	1	Internal circlip
14	81-08-006	1	Knob
15	04-20-820	1	Spring dowel 1/8" dia x 1 1/2" long
■ 16	80-05-007	1	Taper adaptor 3/8 BSP
17	86-50-103	1	Bonded seal 3/8 BSP
18	09-01-121	1	Greaser 1/8" BSP -straight
	86-99-213		SEAL KIT

Assembly notes

- * To be assembled onto cylinder using 'Permabond A113' or equivalent
- To be assembled into cylinder using 'permabond A121' or equivalent
- To be assembled with tap across the body of the ram and with knob to the rear.

Model

REACH RAM

McCOMEL

Temeside Works, Ludlow,
Shropshire, SY8 1JL, England.
Telephone: (0584) 3131.
Telex 35313. Facsimile: (0584) 6463.

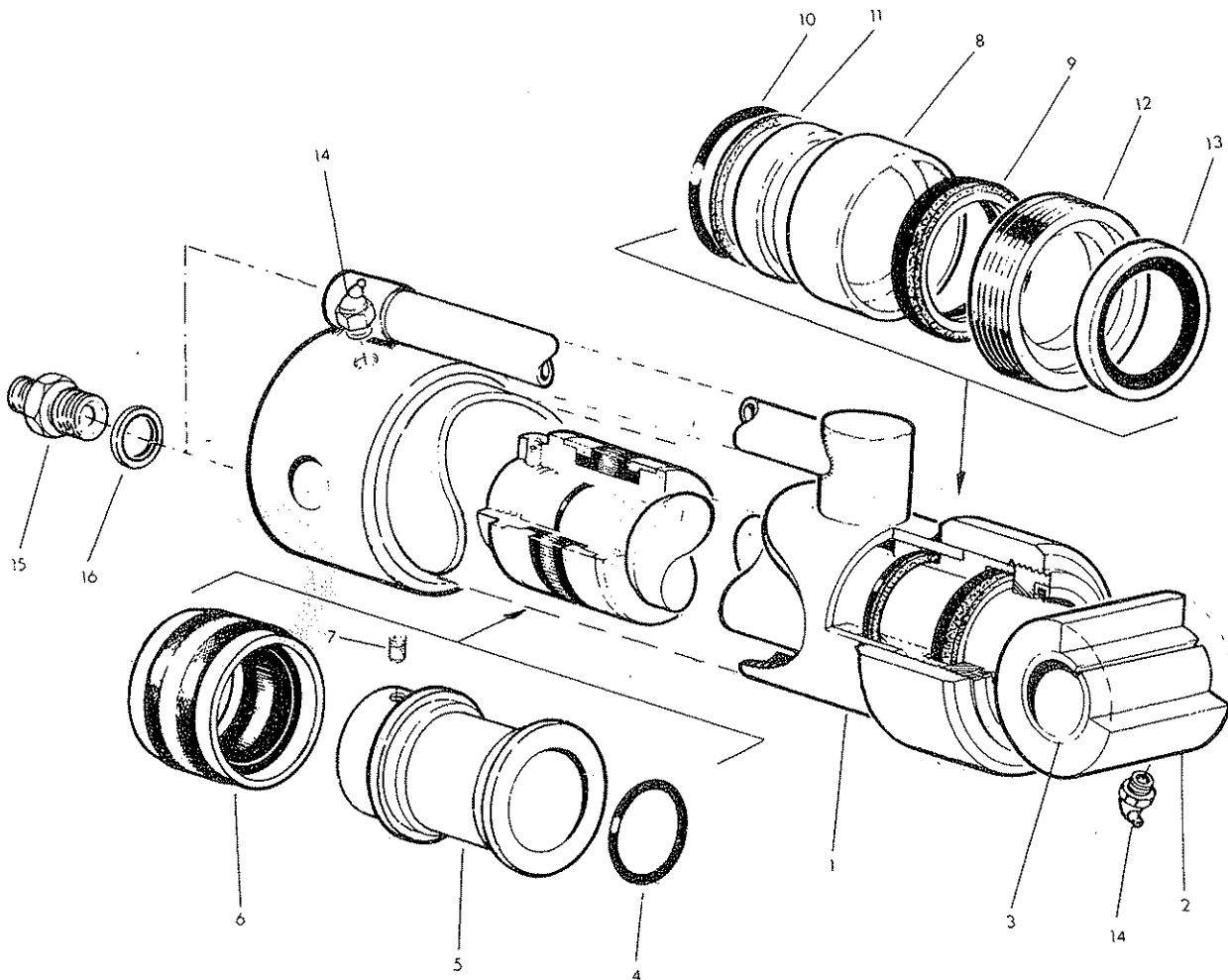
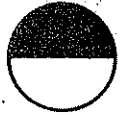

Ref.	Part No.	Qty.	Description
	71-92-050		REACH RAM ASSEMBLY
	71-92-336	1	Basic ram assembly
1	71-02-304	1	Ram cylinder
2	71-92-045	1	Piston rod
3	71-05-050	1	Bush
4	86-00-119	1	'O' ring
5	71-01-165	1	Piston c/w seal and grub screw
6	86-36-131	1	Piston seal
7	93-00-110	1	Grub screw M6 x 8
8	71-01-099	1	Gland housing c/w seal and 'O' ring
9	86-22-127	1	Gland seal
10	86-00-304	1	'O' ring
11	86-09-304	1	Anti extrusion ring
12	71-01-100	1	Gland nut c/w wiper
13	86-40-328	1	Piston rod wiper
14	09-01-124	2	Greaser 1/8 BSP angular 67 $\frac{1}{2}$ ⁰
15	86-50-103	2	Union 3/8 BSP - $\frac{1}{2}$ JIC
16	86-50-103	2	Bonded seal 3/8 BSP
	86-99-102		SEAL KIT

Model

ANGLING RAM

McCONEL

Temeside Works, Ludlow,
Shropshire, SY8 1JL, England.
Telephone: (0584) 3131.
Telex 35313. Facsimile: (0584) 6463.

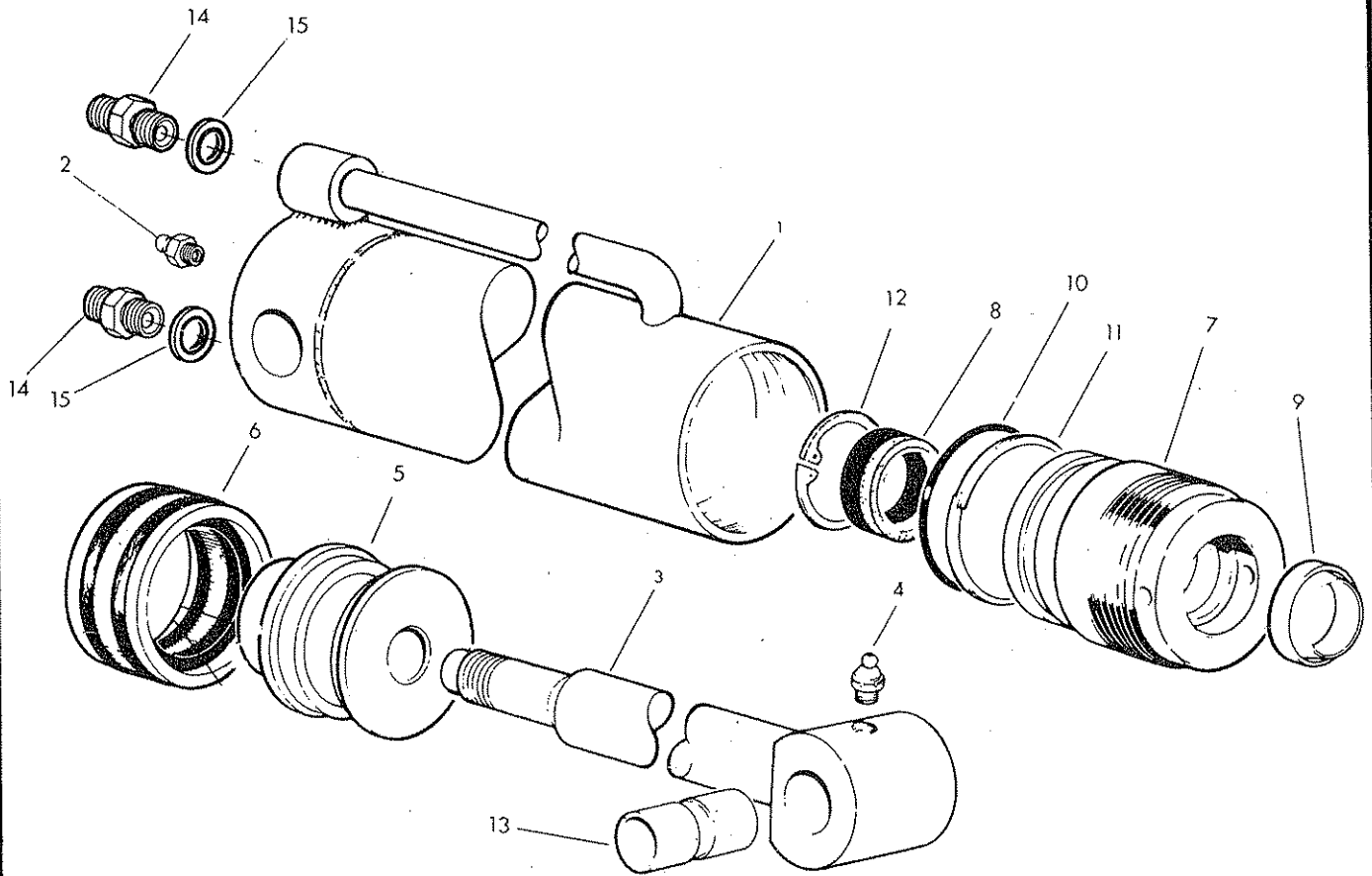
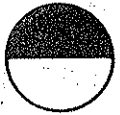

Ref.	Part No.	Qty.	Description
	71-92-051		ANGLING RAM ASSEMBLY
1	71-35-292	1	Ram Cylinder c/w greaser
2	09-01-121	1	Greaser 1/8 BSP-straight
3	71-35-009	1	Piston rod
4	09-01-121	1	Greaser 1/8 BSP-straight
5	71-35-008	1	Piston c/w seal
6	86-38-788	1	Piston seal
7	71-35-291	1	Gland housing c/w seals etc
8	86-29-148	1	Gland seal
9	86-29-149	1	Piston rod wiper seal
10	86-00-302	1	'O' ring
11	86-09-302	1	Anti extrusion ring
12	04-16-240	1	Internal circlip
13	71-05-050	1	Piston rod bush
14	85-81-219	2	Union 1/4 BSP x 1/8 JIC M-M
15	86-50-102	2	Bonded seal 1/4 BSP
	86-99-188		SEAL KIT

Model

LIFT FLOAT KIT

McCONEL

Temeside Works, Ludlow,
Shropshire, SY8 1JL, England.
Telephone: (0584) 3131.
Telex 35313. Facsimile: (0584) 6463.

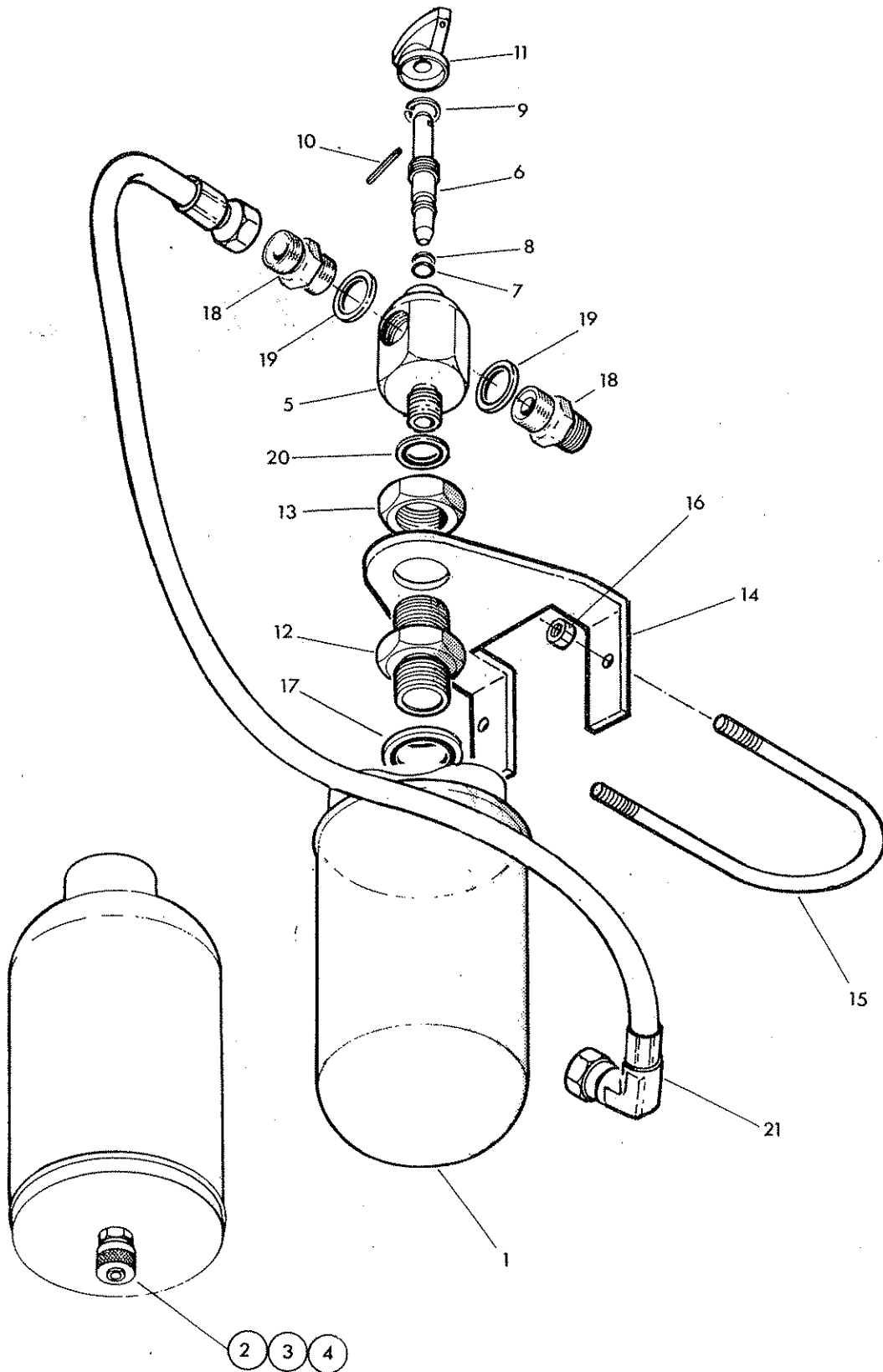

Model

MCCONEL

Temeside Works, Ludlow,
Shropshire, SY8 1JL, England.
Telephone: (0584) 3131.
Telex 35313. Facsimile: (0584) 6463.

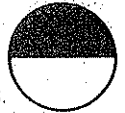

Ref.	Part No.	Qty.	Description
	81-26-275		LIFT FLOAT KIT
1	81-26-271	1	Accumulator (600 psi)
2	81-26-015	1	Charge valve assembly c/w 'O' ring
3	81-26-016	1	Charge valve core
4	86-00-103	1	'O' ring
	71-35-007	1	Tap assembly compr:-
5	71-35-294	1	Tap body
6	71-35-006	1	Tap spindle
7	86-00-107	1	'O' ring
8	86-09-107	1	Anti extrusion ring
9	04-16-110	1	Internal circlip
10	04-20-820	1	Spring dowel
11	81-08-006	1	Knob
12	85-81-205	1	Adaptor
13	85-81-151	1	Black nut
14	81-26-277	1	Bracket
15	81-26-031	1	'U' Bolt M8
16	91-43-004	2	Self locking nut M8
17	85-50-106	1	Bonded seal 3/4" BSP
18	10-75-115	2	Adaptor 3/8 BSP x 1/2 JIC M-M
19	86-50-103	2	Bonded seal 3/8 BSP
20	85-50-102	1	Bonded seal 1/4" BSP
21	85-35-077	1	Hose 1/2 JIC SF-90° x 17" long

Model

OPERATOR GUARD

MCCONEL

Temeside Works, Ludlow,
Shropshire, SY8 1JL, England.
Telephone: (0584) 3131.
Telex 35313. Facsimile: (0584) 6463.

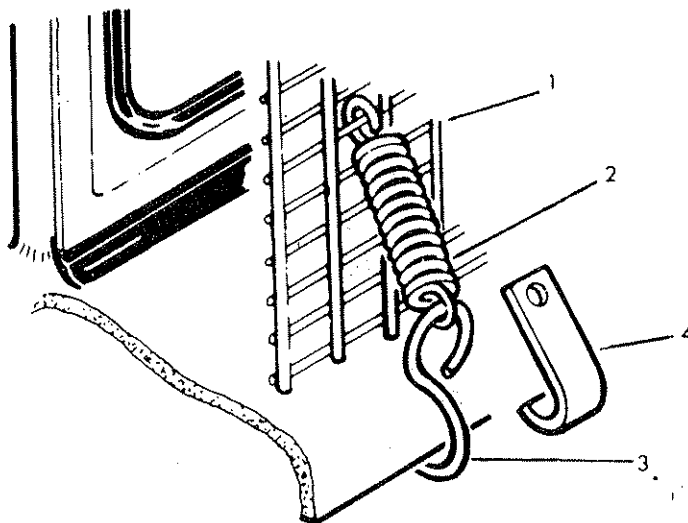
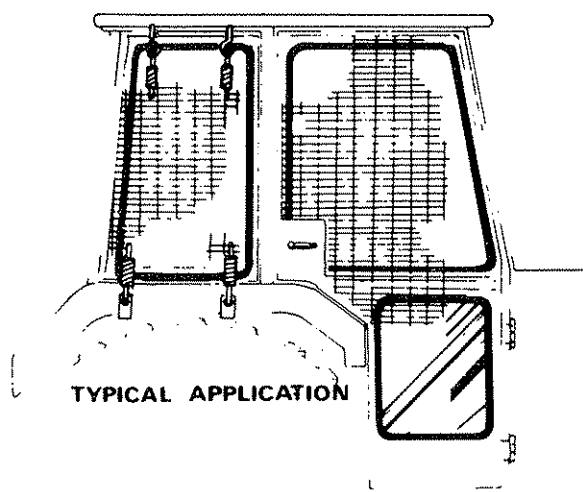

Ref.	Part No.	Qty.	Description
	73-13-324		CAB GUARD KIT
1	73-13-049	1	Guard panel - large
1	73-13-050	1	Guard panel - small
2	60-01-064	12	Spring
3	60-01-065	6	Hook
4	73-13-051	6	Hook

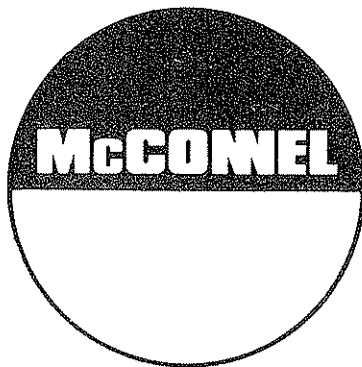

F.W. McConnel Limited, Temeside Works, Ludlow, Shropshire, SY8 1JL, England.
Telephone: (0584) 3131. Telex 35313. Facsimile: (0584) 6463.