

Publication 545
July 2008
Part No. 41571.45

PA8000M Mid-Mount

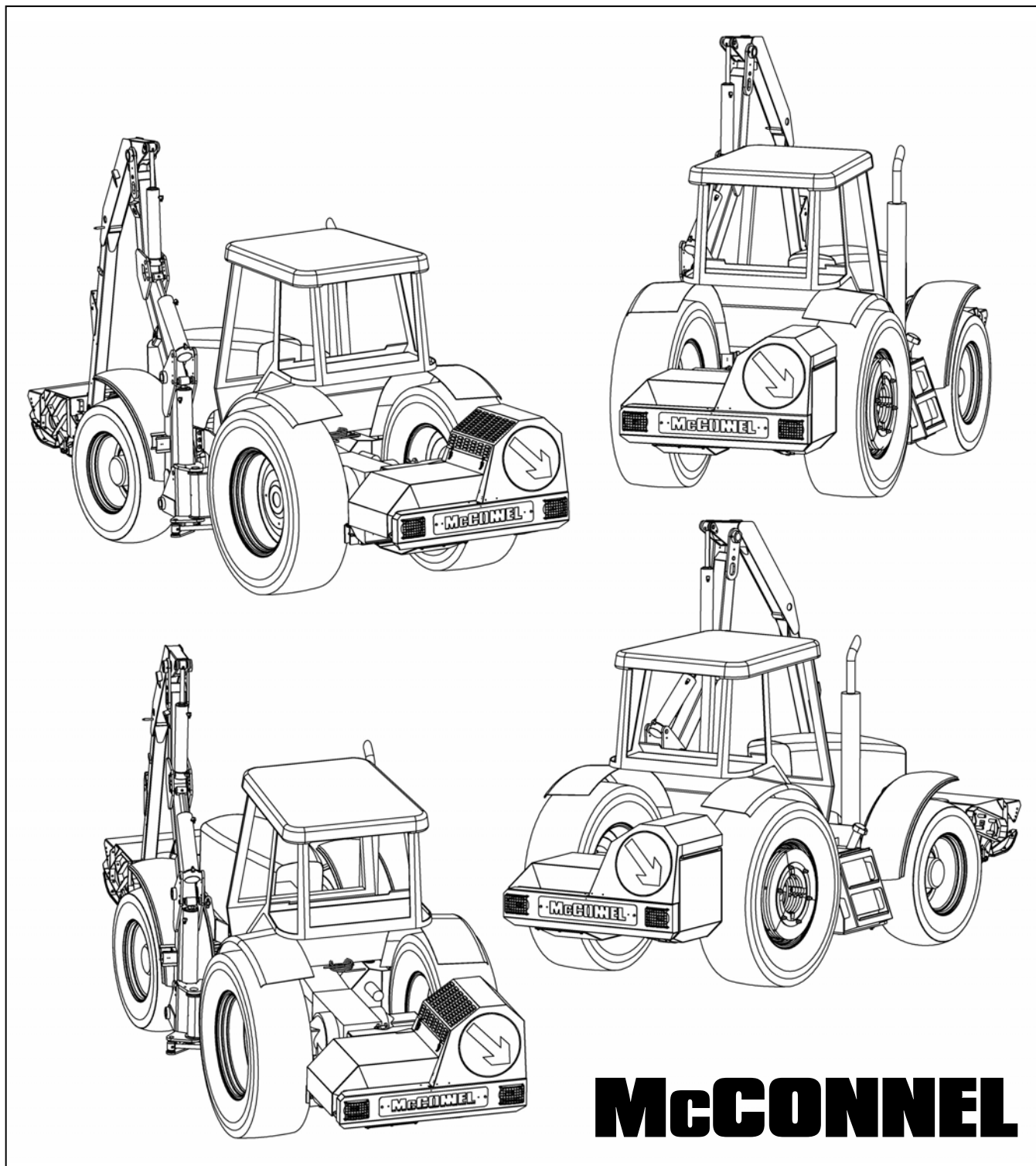

Parts Manual



McCONNEL



For best performance...

USE ONLY McCONNEL SERVICE PARTS

To be assured of the latest design improvements purchase your 'Genuine Replacements' from the Original Equipment Manufacturer:

McCONNEL LIMITED

through your local Dealer or Stockist.

Always quote:

- ***Machine Type***
- ***Serial Number***
- ***Part Number***

*Design Improvements may have altered some of the parts listed in this manual –
The latest part will always be supplied when it is interchangeable with an earlier one.*

CONTENTS

	<i>Page No.</i>
Subframe Assembly	1
Tank Module - MF6475	2
Rear Frame Assembly	3
Intermediate Frame Assembly	5
Pillar Assembly	7
First Arm Assembly	9
Second Arm Assembly	11
Third Arm Assembly	13
Hydraulic Tank Assembly	15
Hydraulic Tank Fittings	17
Piston Pump Bypass	18
Piston Pump & Gearbox Assembly	19
V4 Proportional Control Valve Assembly	21
V4 Armrest Controls	23
V4 Control Box (Mk2)	25
Slew Ram Assembly	27
1st Ram Assembly (Lift)	28
2nd Ram Assembly (Lift)	29
3rd Ram Assembly (Reach)	30
Angling Ram Assembly	31
Charge Filter Assembly	32
Hydraulic Hoses	33
Quick Release Adaptor Module	37
EDS Sensor Module	39
Cooler Assembly	41
Cover Assembly	42
Rear Frame Cover	43
Rear Lighting Kit	44
Axle Locking Kit – MF6475	45
Axle Locking Hydraulic Kit – MF6475	47
Locking Axle Kit Ram Assembly	49
Wheel Weights Kit – MF6475	50
Mounting Frame	51
Transport Cradle – MF6475	52
Cab Guard Kit	53

Model: PA8000M



SUBFRAME ASSEMBLY

Module:
7780511

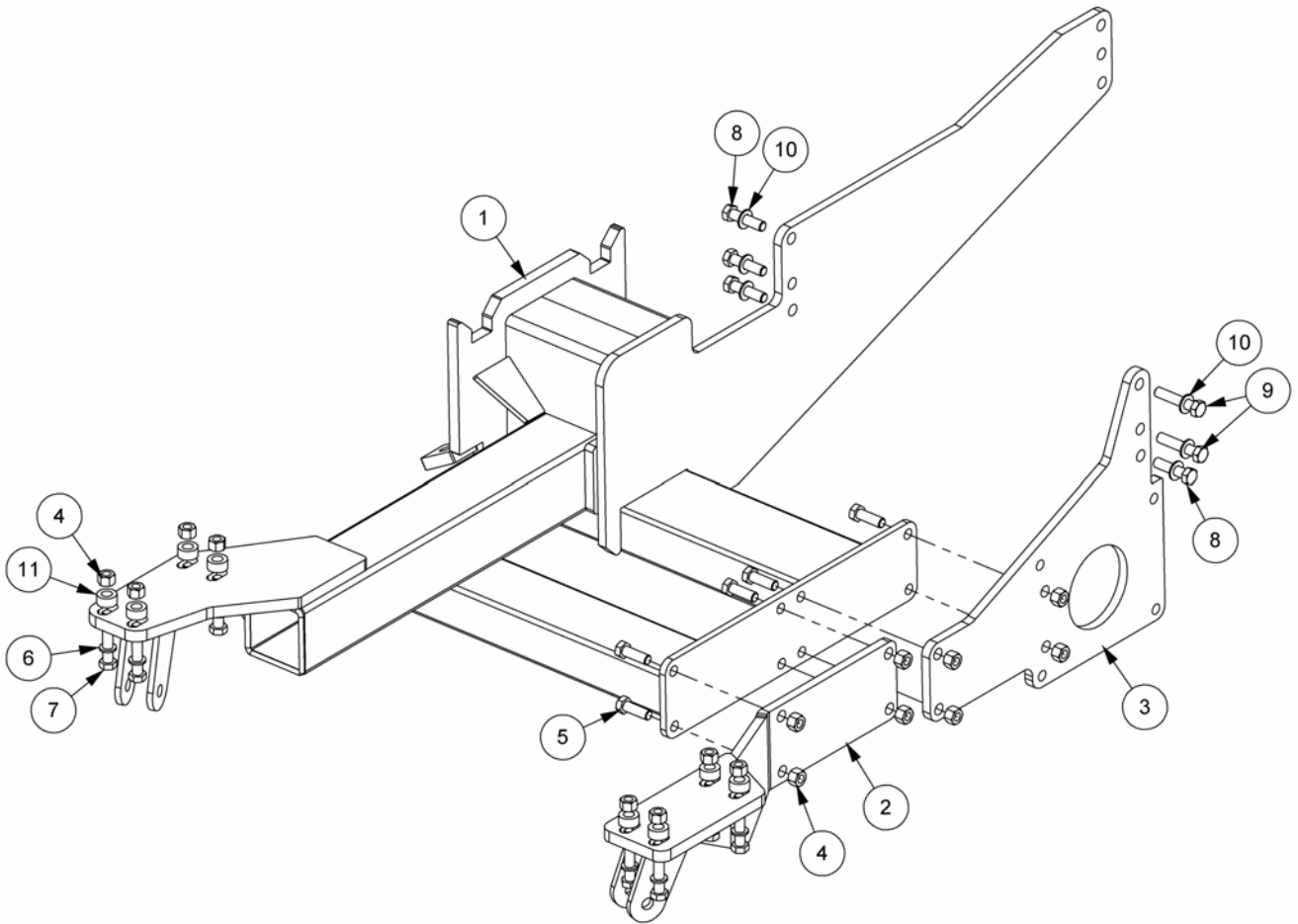

REF.	QTY.	PART No.	DESCRIPTION
		7780511	SUBFRAME ASSEMBLY - L/H Build
1	1	21618.16	SUBFRAME - L/H Build (MF6475)
2	1	21618.17	SUBFRAME HALF - TYPE 2
3	1	21618.18	SUPPORT PLATE
4	16	9143008	SELF-LOCKING NUT
5	8	9213128	BOLT
6	8	9100208	SPRING WASHER
7	8	9213228	BOLT
8	4	9200054	BOLT
9	2	9213208	BOLT
10	6	9100108	FLAT WASHER
11	8	21618.86	SPACER

Model: PA8000M



TANK MODULE – MF6475

Module:
7780512

5 METRE FUEL HOSE - CUT TO FOLLOWING LENGTHS
1 x 2000mm - Fuel Sender to Tractor Engine
1 x 3000mm - Fuel Sender to Breather

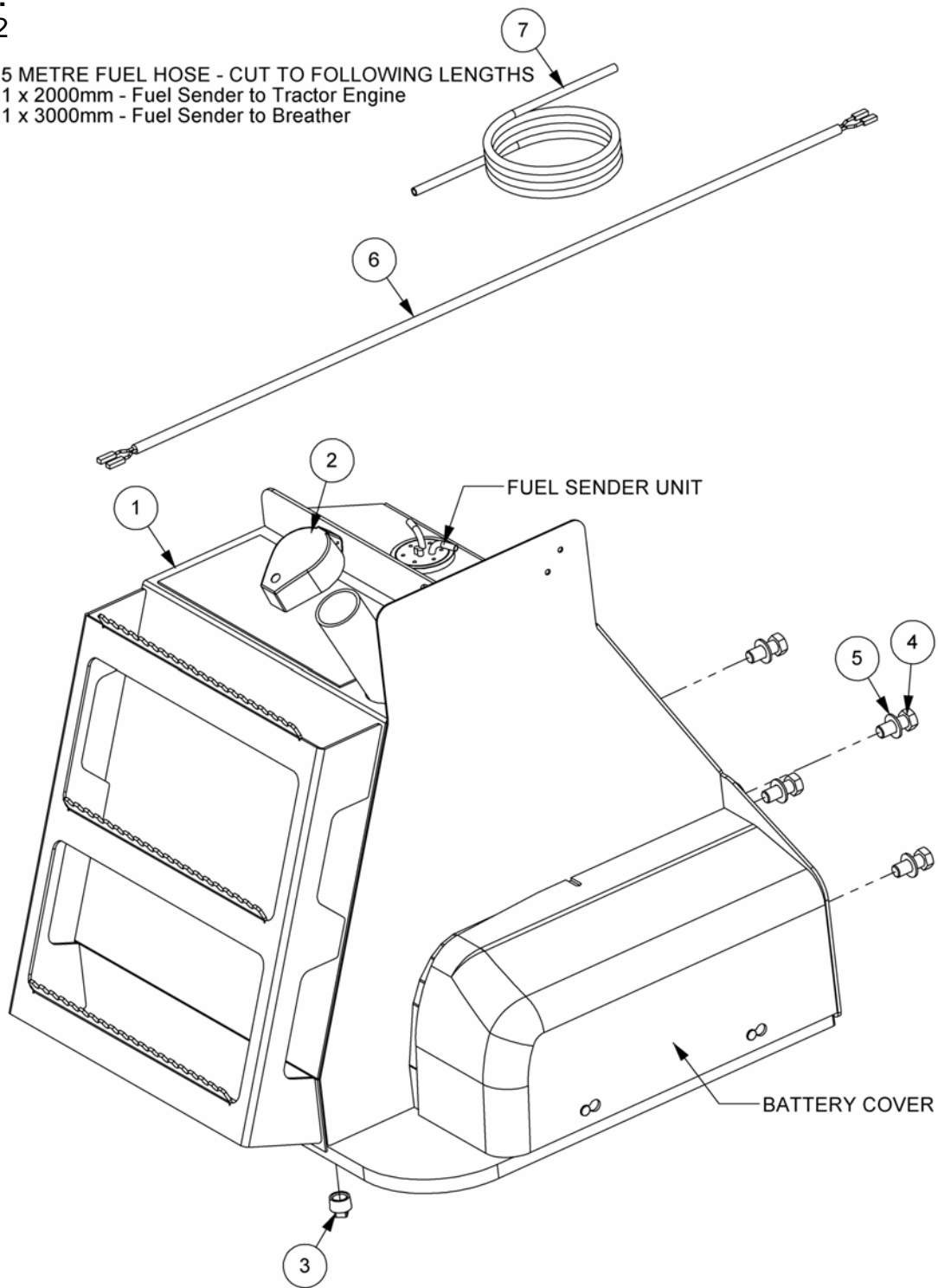

REF.	QTY.	PART No.	DESCRIPTION
		7780512	TANK MODULE - MF6475
1	1	21642.03	TANK ASSEMBLY - MF6475
2	1	21643.01	FILLER CAP - LOCKABLE
3	1	8581203	TAPER PLUG
4	4	9213108	BOLT
5	4	9100108	FLAT WASHER
6	1	43177.69	EXTENSION LOOM 2 CORE (1.25M)
7	1	8501392	FUEL HOSE (5M)

Model: PA8000M



REAR FRAME ASSEMBLY

Module:
7780700

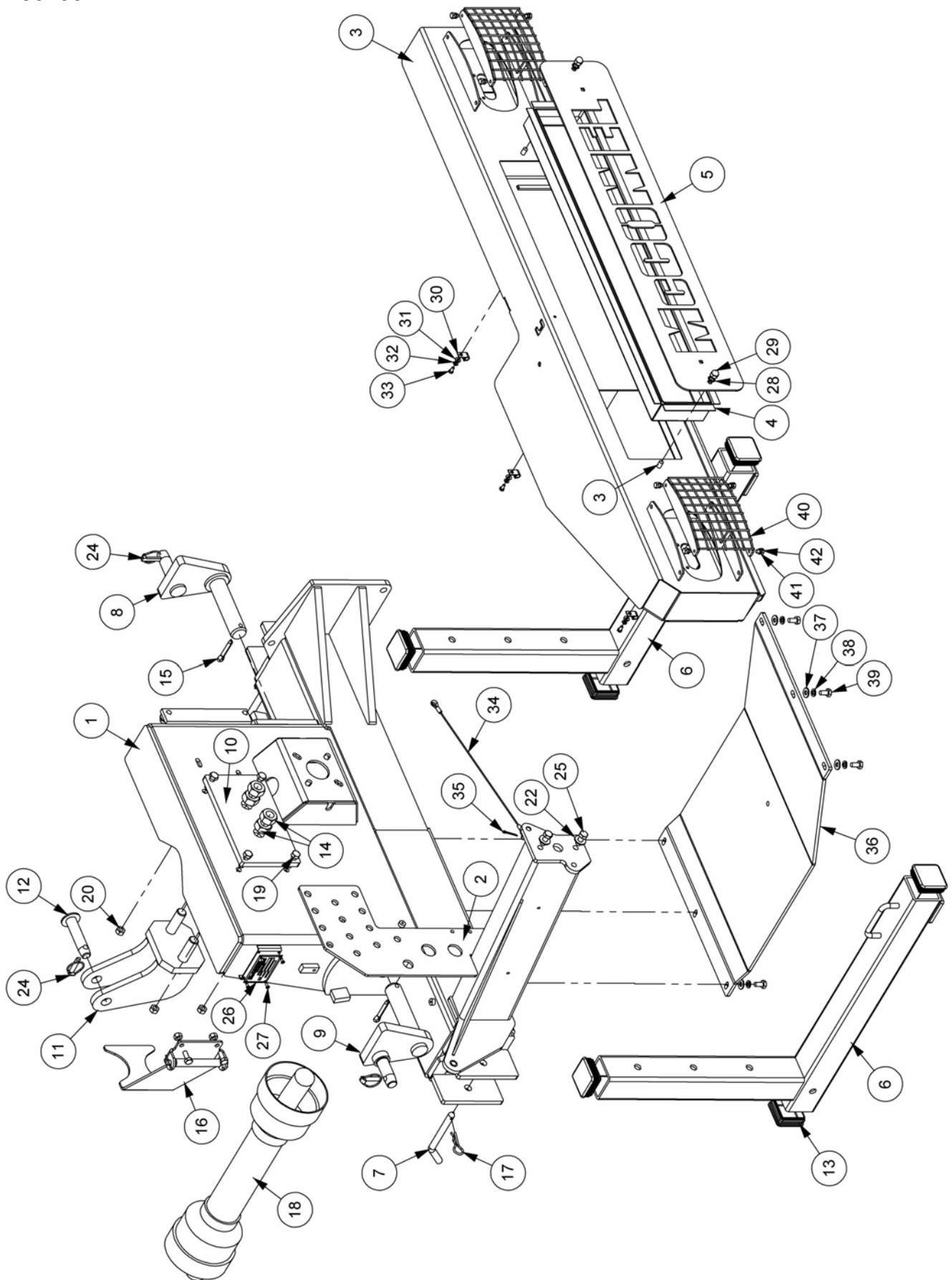

REAR FRAME ASSEMBLY

REF.	QTY.	PART No.	DESCRIPTION
		7780700	REAR FRAME ASSEMBLY - L/H Build
1	1	21377.03	MAIN FRAME - L/H Build
2	1	21391.03	OUTRIGGER
3	1	21390.02	REAR BAR - L/H Build
4	1	21387.01	COOLER BASKET
5	1	21386.01	COOLER BASKET CLAMP
6	2	21068.03	STAND LEG
7	2	43327.02	LEG PIN
8	1	43319.04	LIFT LINK - R/H
9	1	43319.03	LIFT LINK - L/H
10	1	45807.02	REACTION PLATE
11	1	21675.02	TOP HITCH BRACKET
12	1	7560144	TOP LINK PIN
13	6	41580.01	PLASTIC PLUG
14	4	9113009	NUT
15	2	9501509	SPLIT PIN
16	1	21187.01	PTO SUPPORT BRACKET KIT
17	2	0431105	SPRING COTTER
18	1	7650250	DRIVE SHAFT
19	4	9213086	BOLT
20	6	9143006	SELF-LOCKING NUT
21	2	9313056	SETSCREW
22	4	9100106	FLAT WASHER
23	4	9100206	SPRING WASHER
24	3	0431217	LINCH PIN
25	4	9313066	SETSCREW
26	1	1335246	SERIAL No. PLATE
27	4	1069088	POP RIVET
28	2	9100405	EXTERNAL SHAKEPROOF WASHER
29	2	9100025	DOME NUT
30	5	21151.01	D CLIP
31	5	9100103	FLAT WASHER
32	5	9100203	SPRING WASHER
33	5	9313023	SETSCREW
34	1	45444.02	RESTRAINT CABLE
35	1	9501255	SPLIT PIN
36	1	21470.01	BASH PLATE
37	6	9100105	FLAT WASHER
38	6	9100205	SPRING WASHER
39	6	9313045	SETSCREW
40	2	21469.01	LAMP GUARD
41	8	9100404	SHAKEPROOF WASHER
42	8	9313024	SETSCREW

Model: PA8000M



INTERMEDIATE FRAME

Module:
7780509

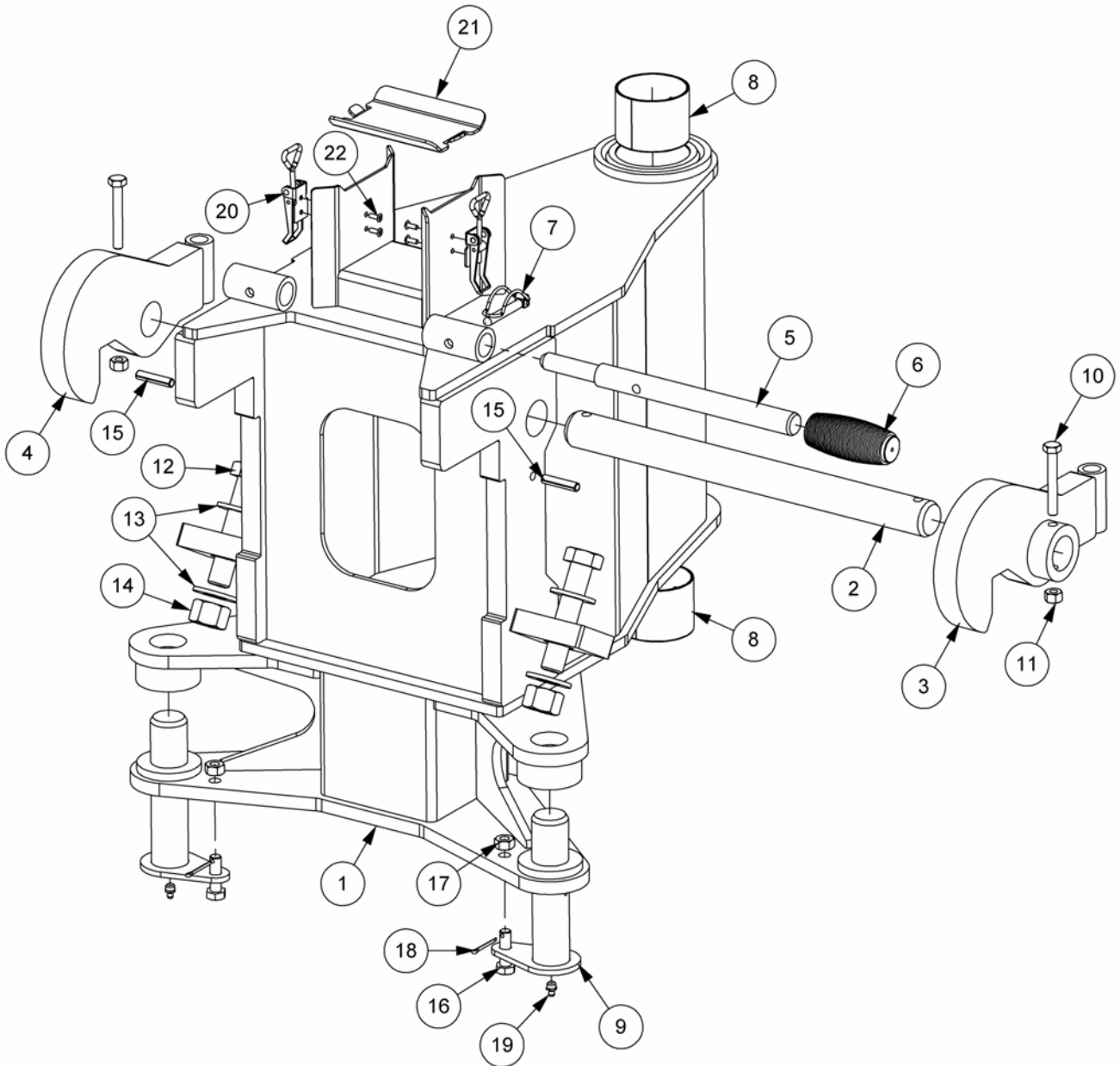

INTERMEDIATE FRAME

REF.	QTY.	PART No.	DESCRIPTION
		7780509	INTERMEDIATE FRAME
1	1	21615.03	INTERMEDIATE FRAME
2	1	21912.01	CATCH PIVOT BAR
3	1	21900.01	CATCH HOOK - TYPE 1
4	1	21900.02	CATCH HOOK - TYPE 2
5	1	21909.01	CATCH HANDLE
6	1	21913.01	HANDLE GRIP
7	1	0431216	LYNCH PIN
8	2	42654.06	PM 7560 DX
9	2	43324.05	PIN
10	2	9213155	BOLT
11	2	9143005	SELF-LOCKING NUT
12	2	05.285.05	BOLT
13	4	9100109	FLAT WASHER
14	2	9143009	SELF-LOCKING NUT
15	2	0422628	SPRING DOWEL
16	2	45416.01	SPECIAL SETCREW
17	2	9143006	SELF-LOCKING NUT
18	2	9501325	SPLIT PIN
19	3	0901121	GREASE NIPPLE
20	2	43449.02	OVERCENTRE FASTENER
21	1	21989.01	CLAMP PLATE
22	4	1069088	POP RIVET

Model: PA8000M



PILLAR ASSEMBLY

Module:
7780510 – L/H Build

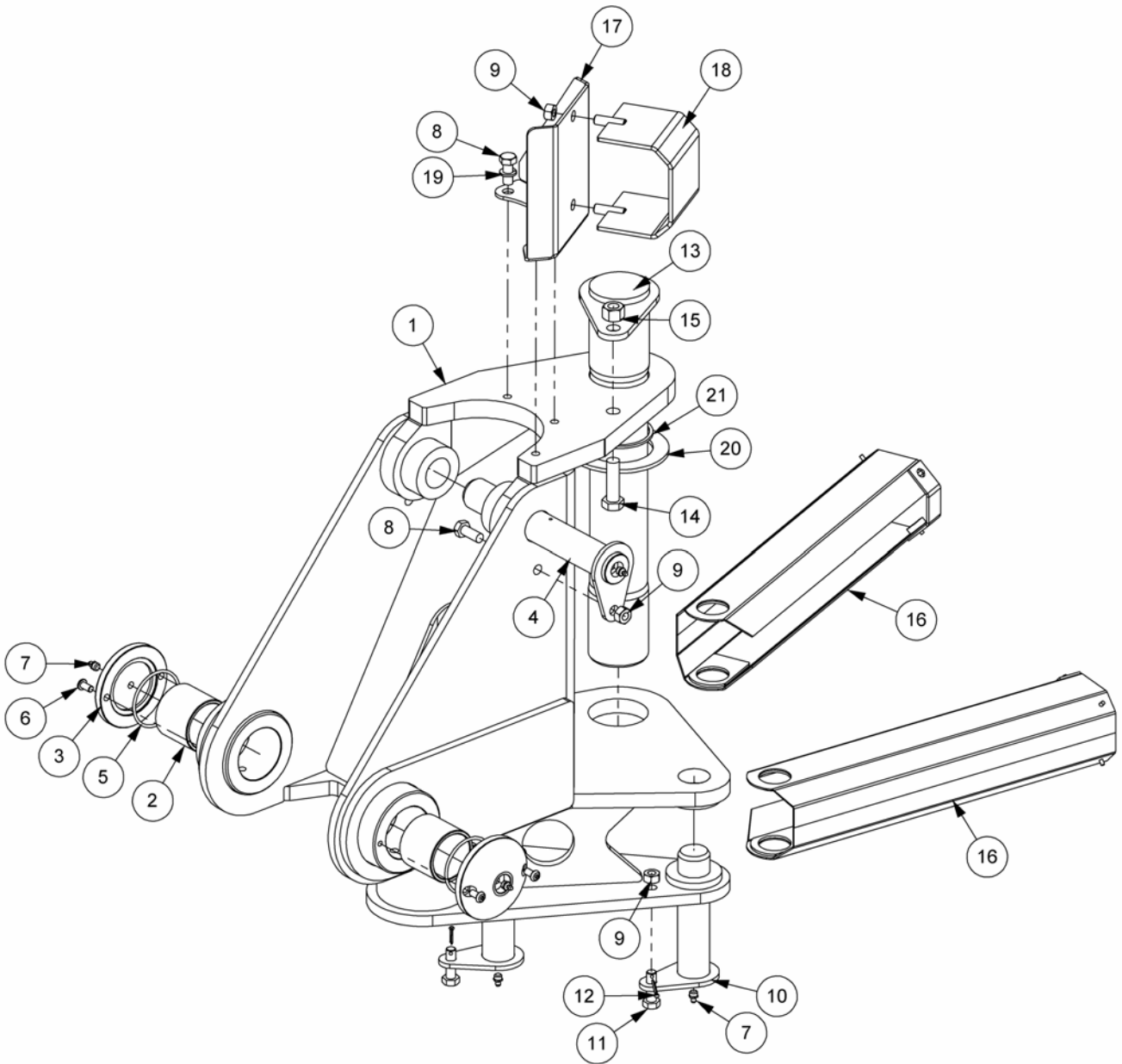

PILLAR ASSEMBLY

REF.	QTY.	PART No.	DESCRIPTION
		7780510	PILLAR ASSEMBLY - L/H Build
1	1	21613.03	SLEW COLUMN
2	2	08.297.06	BUSH
3	2	21077.01	PIN CAP
4	1	43324.09	PIN
5	2	8600310	O RING
6	4	9300159	BUTTON HEAD SOCKET SCREW
7	5	0901121	GREASE NIPPLE
8	4	9313066	SETSCREW
9	5	9143006	SELF-LOCKING NUT
10	2	43324.05	PIN
11	2	45416.01	SPECIAL SETCREW
12	2	9501325	SPLIT PIN
13	1	21614.04	SLEW PIVOT PIN
14	1	9313117	SETSCREW
15	1	9143007	SELF-LOCKING NUT
16	2	21972.02	RAM GUARD
17	1	21985.01	HOSE BRACKET - L/H Build
18	1	21987.01	HOSE RESTRAINT
19	3	9100206	SPRING WASHER
20	1	21652.01	THRUST WASHER
21	1	22013.01	THRUST WASHER LOCATOR

Model: PA8000M



FIRST ARM ASSEMBLY

Module:
7780503 – L/H Build

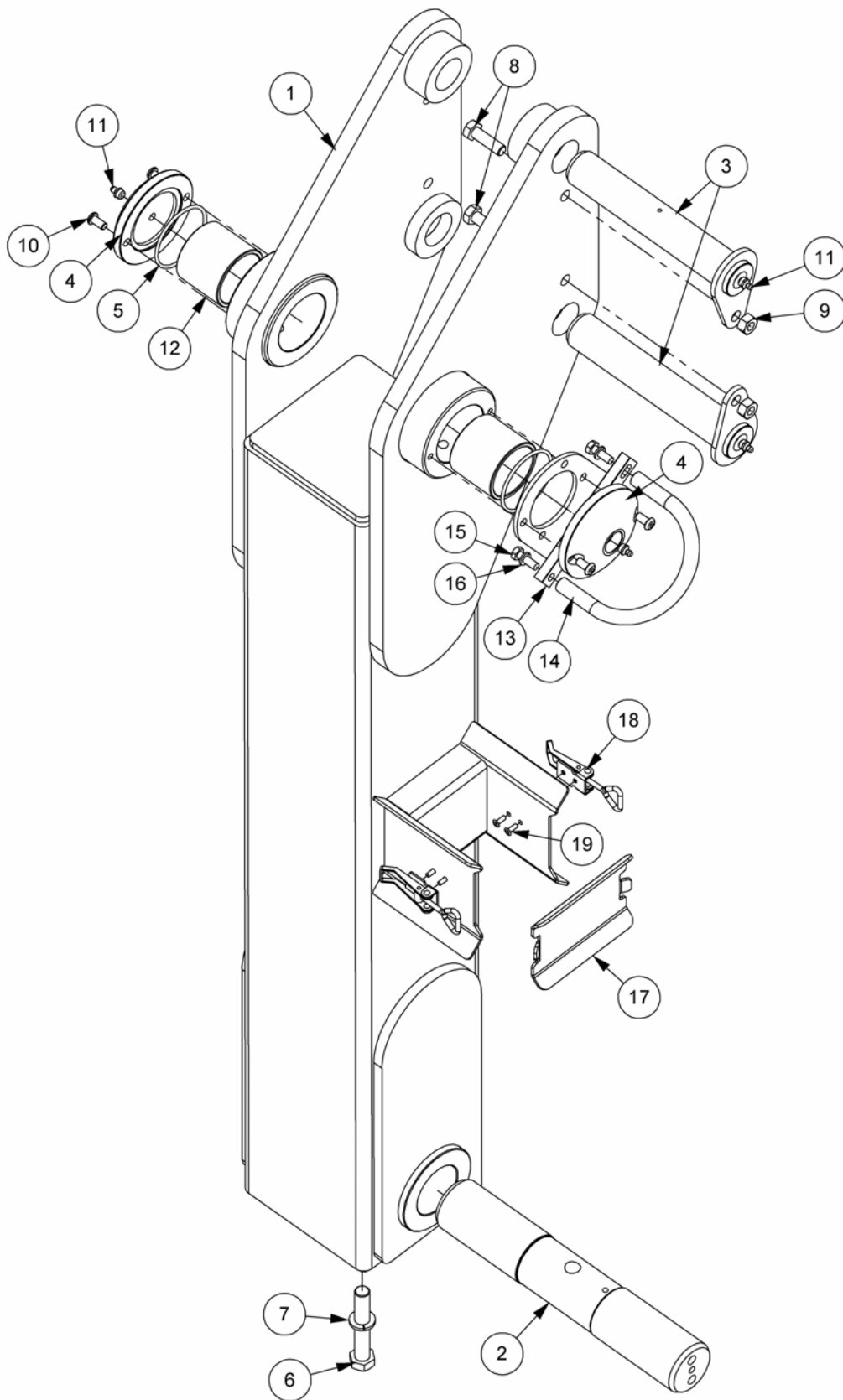

FIRST ARM ASSEMBLY

REF.	QTY.	PART No.	DESCRIPTION
		7780503	FIRST ARM ASSEMBLY
1	1	21619.01	FIRST ARM - L/H Build
2	1	21078.04	PIVOT PIN
3	2	43324.08	PIN
4	2	21077.01	PIN CAP
5	2	8600310	O RING
6	1	9213207	BOLT
7	1	9100207	SPRING WASHER
8	2	9213086	BOLT
9	2	9143006	SELF-LOCKING NUT
10	4	9300159	BUTTON HEAD SOCKET SCREW
11	4	0901121	GREASE NIPPLE
12	2	08.297.06	BUSH
13	1	21129.03	HOSE GUIDE BRACKET
14	1	43048.05	HOOK
15	2	9313054	SETSCREW
16	2	9100204	SPRING WASHER
17	1	21989.01	CLAMP PLATE
18	2	43449.02	OVERCENTRE FASTENER
19	4	1069088	POP RIVET

Model: PA8000M



SECOND ARM ASSEMBLY

Module:
7780504

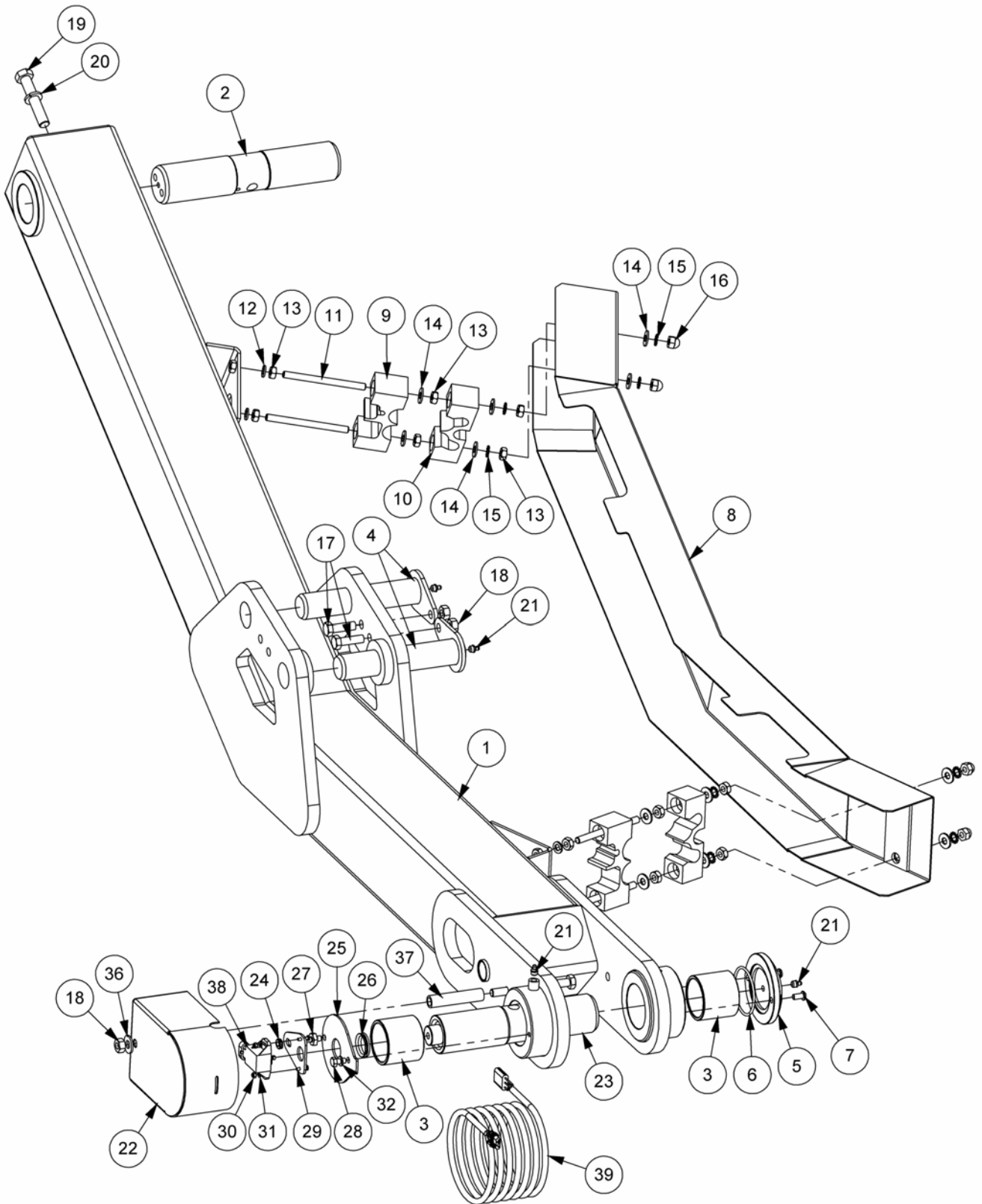

SECOND ARM ASSEMBLY

REF.	QTY.	PART No.	DESCRIPTION
		7780504	SECOND ARM ASSEMBLY
1	1	21620.01	SECOND ARM
2	1	21078.05	PIVOT PIN
3	2	08.297.06	BUSH
4	2	43324.07	PIN
5	1	21077.01	PIN CAP
6	1	8600310	O RING
7	2	9300159	BUTTON HEAD SOCKET SCREW
8	1	21638.02	HOSE COVER
9	2	42024.15	HOSE MULTI CLAMP
10	2	42024.16	HOSE MULTI CLAMP - UPPER
11	4	42198.01	STUD
12	4	9100205	SPRING WASHER
13	12	9113005	PLAIN NUT
14	12	9100105	FLAT WASHER
15	8	9100405	EXTERNAL SHAKEPROOF WASHER
16	4	9100025	DOME NUT
17	2	9313086	SETSCREW
18	3	9143006	SELF-LOCKING NUT
19	1	9213187	BOLT
20	1	9100207	SPRING WASHER
21	4	0901121	GREASE NIPPLE
22	1	21737.02	EDS SENSOR COVER
23	1	21078.07	PIVOT PIN
24	1	43356.01	GROMMET
25	1	21117.01	COVER PLATE
26	1	8629232	V RING
27	1	43014.02	LOCATING STUD
28	1	9313034	SETSCREW
29	2	9300162	POSI PANHEAD SCREW
30	2	05.948.33	SELF-LOCKING NUT
31	2	9100101	FLAT WASHER
32	1	9100204	SPRING WASHER
33	1	21118.01	REACTION PLATE
34	1	9363023	GRUB SCREW (WITH TUFLOCK)
35	1	9213266	BOLT
36	1	9100106	FLAT WASHER
37	1	22075.01	SPACER - SENSOR COVER
38	1	8402279	REACH ANGLE SENSOR (120°)
39	1	21163.05	LOOM - REACH SENSOR
40	1	45425.07	SENSOR EXTENSION
41	1	0430110	SPRING DOWEL

Model: PA8000M



THIRD ARM ASSEMBLY

Module:
7780505

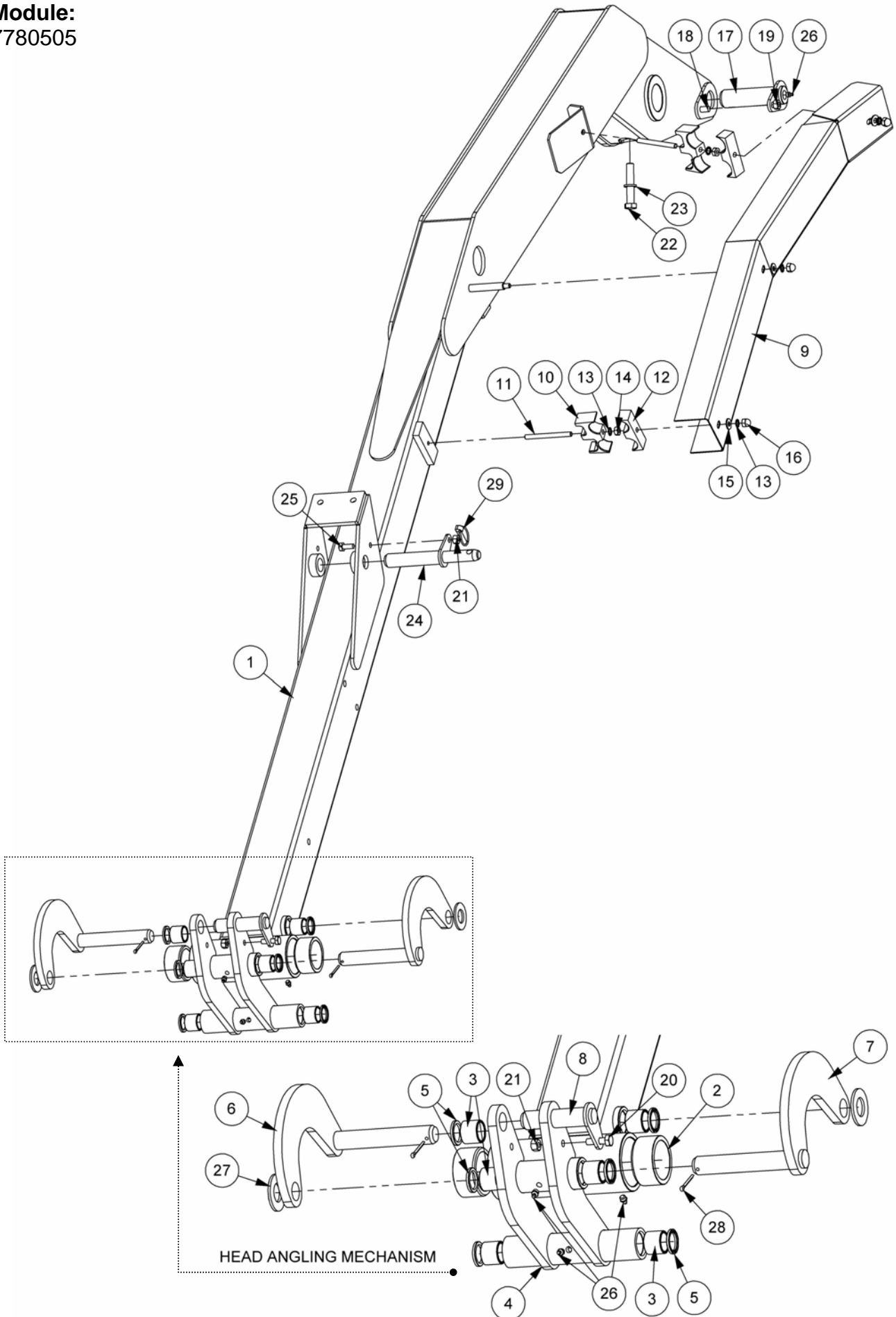

THIRD ARM ASSEMBLY

REF.	QTY.	PART No.	DESCRIPTION
		7780505	THIRD ARM ASSEMBLY
1	1	21622.01	THIRD ARM
2	2	7136035	PLASTIC BUSH
3	6	08.297.04	BUSH
4	1	42647.02	SLAVE LINK
5	6	8629218	LIP SEAL
6	1	42646.03	RADIUS ARM - TYPE 1
7	1	42646.04	RADIUS ARM - TYPE 2
8	1	42684.05	PIN
9	1	21638.01	HOSE COVER
10	2	06.430.18	HOSE CLAMP - LOWER
11	2	42198.02	STUD
12	2	06.430.17	HOSE CLAMP - UPPER
13	5	9100405	EXTERNAL SHAKEPROOF WASHER
14	2	9113005	PLAIN NUT
15	3	9100105	FLAT WASHER
16	3	9100025	DOME NUT
17	1	43324.11	PIN
18	1	9313086	SETSCREW
19	1	9143006	SELF-LOCKING NUT
20	1	9313075	SETSCREW
21	2	9143005	SELF-LOCKING NUT
22	1	9213187	BOLT
23	1	9100207	SPRING WASHER
24	1	42684.09	PIN
25	1	9313055	SETSCREW
26	5	0901121	GREASE NIPPLE
27	2	05.281.18	FLAT WASHER
28	2	9501406	SPLIT PIN
29	1	0431217	LINCH PIN

Model: PA8000M



HYDRAULIC TANK ASSEMBLY

Module:
7780702

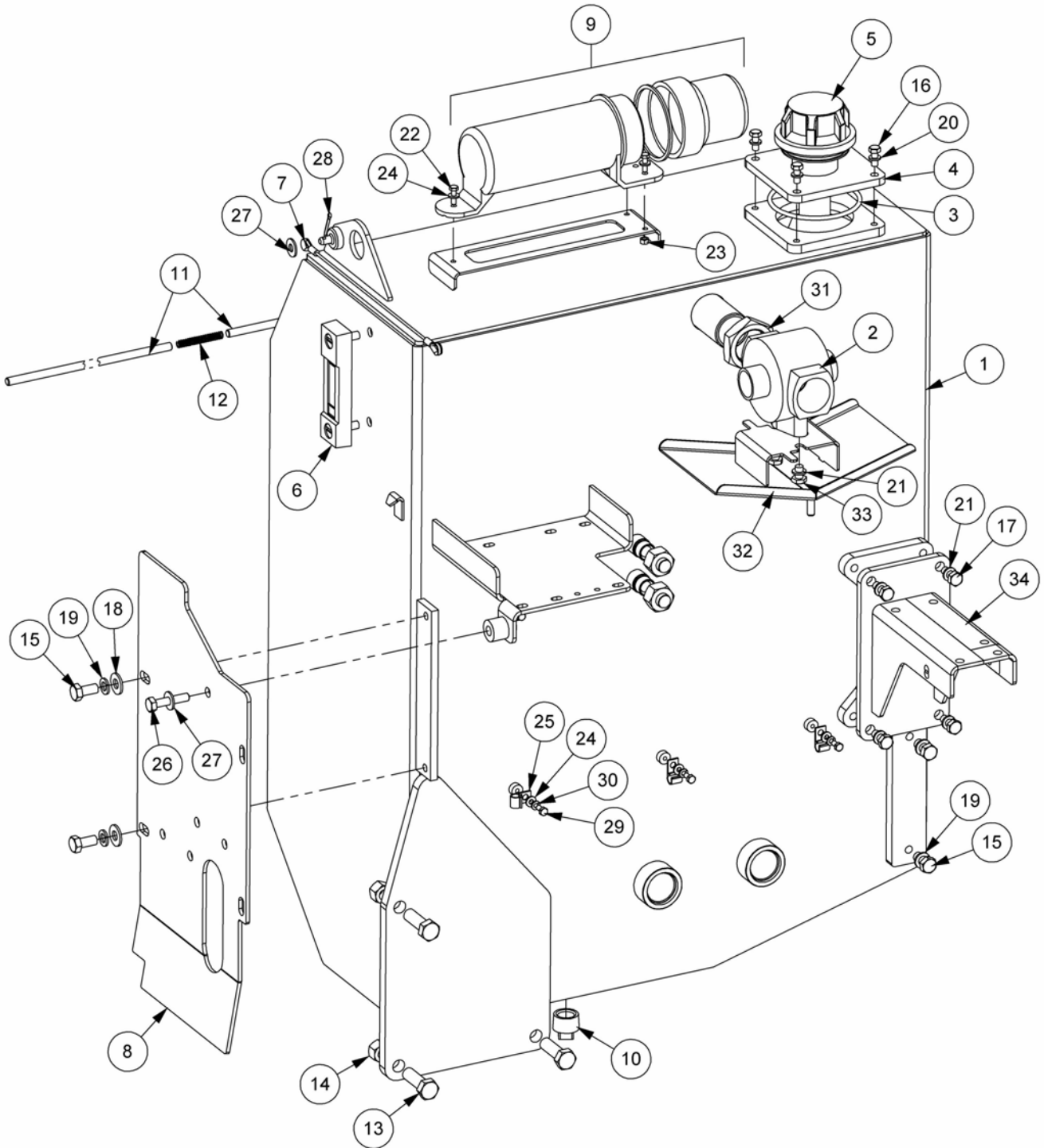

HYDRAULIC TANK ASSEMBLY

REF.	QTY.	PART No.	DESCRIPTION
		7780702	HYDRAULIC TANK ASSEMBLY - L/H Build
1	1	21066.06	OIL TANK - L/H Build
2	1	8401060	RETURN FILTER HEAD
3	1	8600151	O RING
4	1	43175.01	COVER PLATE
5	1	8401074	FILLER BREATHER
6	1	8401048	LEVEL GAUGE
7	1	45444.02	RESTRAINT CABLE
8	1	21074.03	SHIELD PLATE - PISTON L/H Build
9	1	46505.01	LITERATURE HOLDER
10	1	8581203	TAPER PLUG
11	2	21325.03	COVER PIVOT ROD
12	1	21326.01	COMPRESSION SPRING
13	3	9213107	BOLT
14	3	9143007	SELF-LOCKING NUT
15	4	9313056	SETSCREW
16	4	9313044	SETSCREW
17	4	9313055	SETSCREW
18	2	9100106	FLAT WASHER
19	4	9100206	SPRING WASHER
20	4	9100204	SPRING WASHER
21	6	9100205	SPRING WASHER
22	3	9313043	SETSCREW
23	3	9143003	SELF-LOCKING NUT
24	7	9100103	FLAT WASHER
25	4	21151.01	D CLIP
26	1	9213105	BOLT
27	2	9100105	FLAT WASHER
28	1	9501255	SPLIT PIN
29	4	9313023	SETSCREW
30	4	9100203	SPRING WASHER
31	1	8581422	ADAPTOR BACKNUT
32	1	21416.01	FILTER TRAY
33	2	9313035	SETSCREW
34	1	21104.03	VALVE BRACKET

Model: PA8000M



HYDRAULIC TANK FITTINGS

Module:
7780730

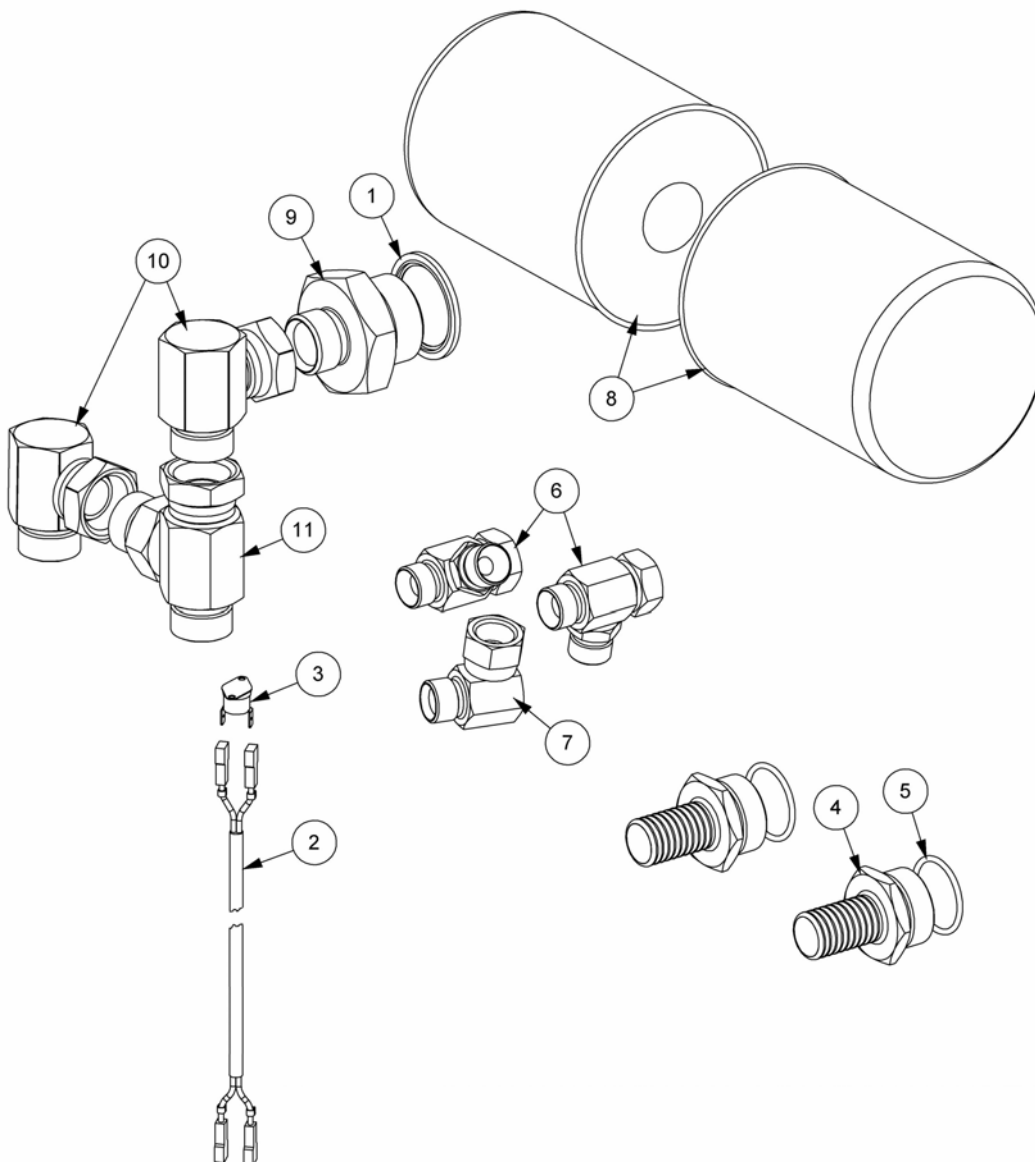

REF.	QTY.	PART No.	DESCRIPTION
		7780730	HYDRAULIC TANK FITTINGS
1	1	8650224	BONDED SEAL
2	1	43177.30	LOOM -THERMAL CUTOUT
3	1	8402236	THERMAL CUTOUT
4	2	8581383	SUCTION ADAPTOR
5	2	8700784	O RING
6	2	8581460	ADAPTOR TEE
7	1	8581338	ADAPTOR - 90°
8	2	8401070	FILTER (10 MICRON)
9	1	8581291	ADAPTOR
10	2	8581212	BLOCK ELBOW - 90°
11	1	04.056.02	SWIVEL TEE

Model: PA8000M



PISTON PUMP BYPASS

Module:
7780715

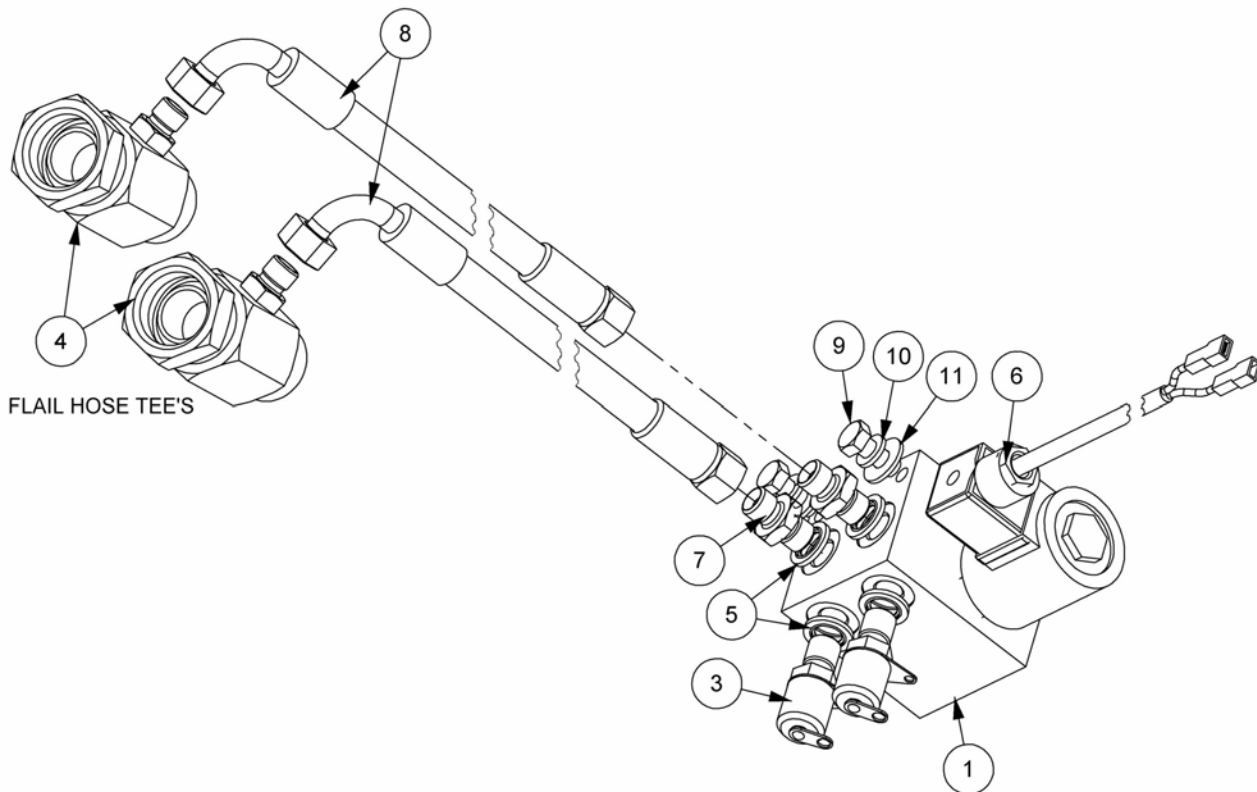

REF.	QTY.	PART No.	DESCRIPTION
		7780715	PISTON PUMP BYPASS ASSEMBLY
1	1	8132270	BLOCK - PUMP BYPASS
2	1	8130192	CARTRIDGE VALVE - 2 WAY
3	2	8131008	TEST POINT
4	2	04.056.33	ADAPTOR TEE
5	4	8650102	BONDED SEAL
6	1	43177.57	LOOM - PISTON PUMP BYPASS
7	2	8581169	ADAPTOR
8	2	10.002.07	HOSE - 1/4" BSP FS/F90 x 350mm
9	2	9313044	SETSCREW
10	2	9100204	SPRING WASHER
11	2	9100104	FLAT WASHER

Model: PA8000M



PISTON PUMP & GEARBOX

Module:
7780708

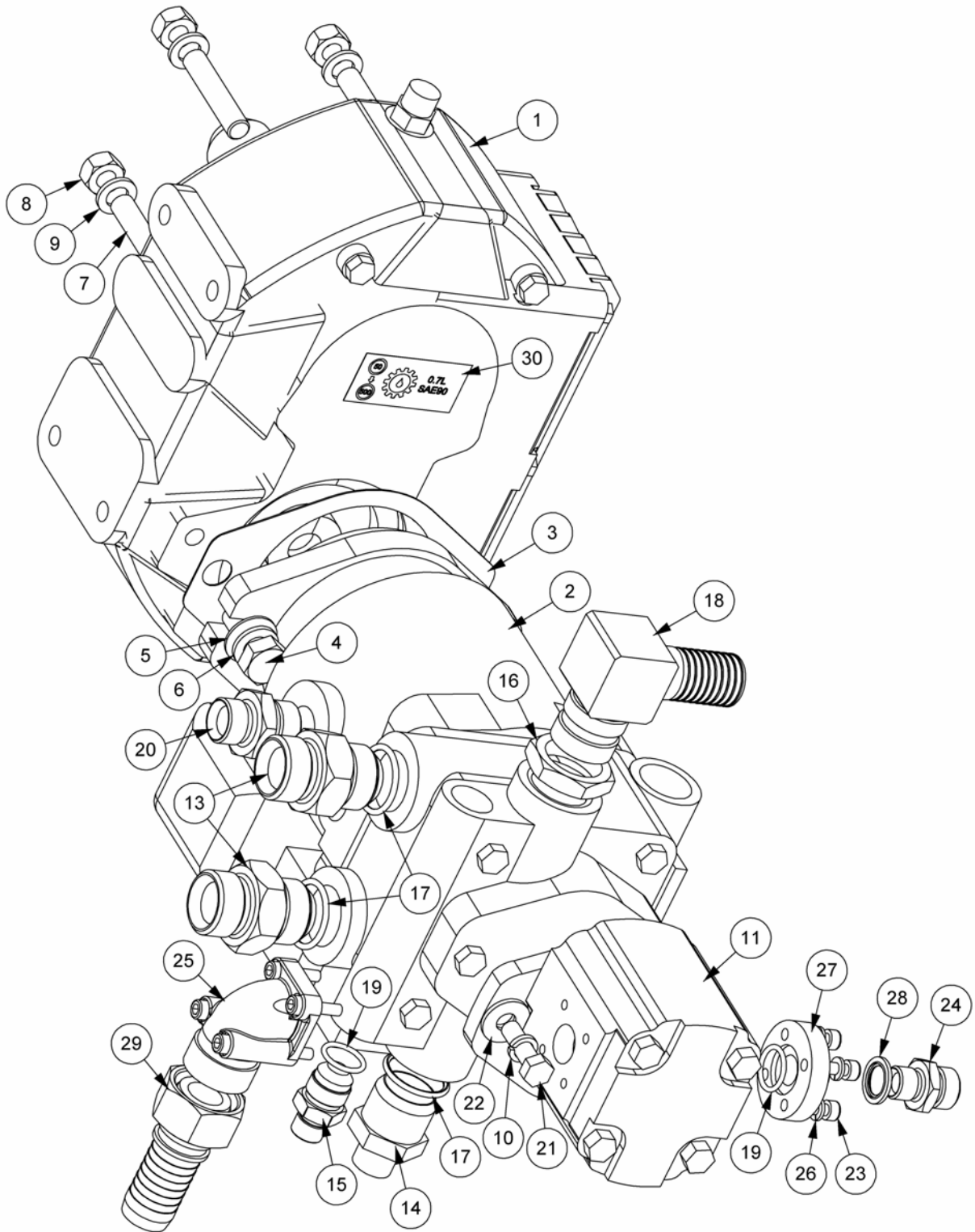

PISTON PUMP & GEARBOX

REF.	QTY.	PART No.	DESCRIPTION
		7780708	PISTON PUMP & GEARBOX - L/H Build
1	1	8013514	GEARBOX 3.6:1 (15T)
2	1	8201699	PISTON PUMP
3	1	7550048	GASKET
4	2	05.839.01	BOLT
5	2	9100020	FLAT WASHER
6	2	05.282.08	SPRING WASHER
7	4	04.282.65	STUD
8	4	9113006	NUT
9	4	9100206	SPRING WASHER
10	4	0100203	SPRING WASHER
11	1	8201706	PISTON PUMP
12	1	43177.27	LOOM - PISTON ROTOR CONTROL
13	2	8581256	ADAPTOR (JIC)
14	1	8581321	ADAPTOR
15	1	520622	ADAPTOR (JIC)
16	1	7550047	LOCKNUT
17	4	8600916	O RING
18	1	8581316	ELBOW (JIC) - LOW PRESSURE
19	2	8600910	O RING 910
20	1	8581459	ADAPTOR
21	2	0312103	HEX SCREW
22	2	0100103	FLAT WASHER
23	4	9343043	CAPSCREW
24	1	6000112	ADAPTOR
25	1	8013124	FLANGE - 90°
26	4	9100203	SPRING WASHER
27	1	8013123	PUMP CONNECTION
28	1	8650103	BONDED SEAL
29	1	8581419	ADAPTOR - LOW PRESSURE
30	1	1290092	BIMA GEARBOX DECAL

Model: PA8000M



V4 PROP. CONTROL VALVE

Module:
7780711

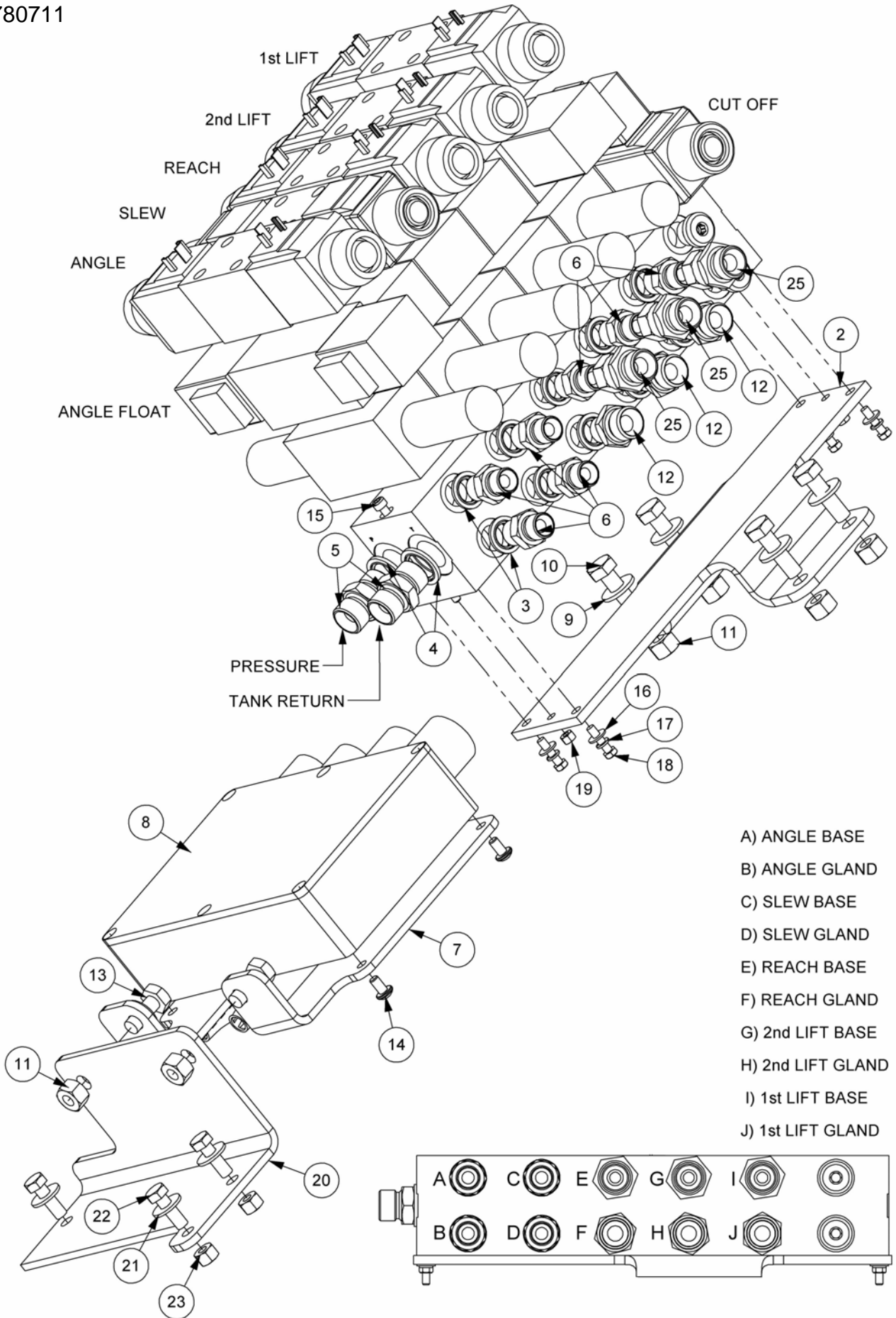

V4 PROP. CONTROL VALVE

REF.	QTY.	PART No.	DESCRIPTION
		7780711	V4 PROP. CONTROL ASSEMBLY - L/H Build
1	1	EHV2535	PROP VALVE ASSEMBLY
2	1	21437.01	CONTROL VALVE BRACKET - L/H Build
3	10	8650103	BONDED SEAL
4	2	8650104	BONDED SEAL
5	2	8581110	ADAPTOR
6	7	6000113	ADAPTOR
7	1	21275.01	PLATE CONTROL BRACKET
8	1	21164.06	V4 ACB CONTROLLER
9	6	9100105	FLAT WASHER
10	4	9313075	SETSCREW
11	6	9143005	SELF-LOCKING NUT
12	3	6000112	ADAPTOR
13	2	9313055	SETSCREW
14	4	9300164	TAPTITE
15	2	9243162	CAPSCREW
16	4	9100102	FLAT WASHER
17	4	9100202	SPRING WASHER
18	4	12.738.20	SETSCREW
19	2	9143002	SELF LOCKING NUT
20	1	21275.02	ACB MOUNTING BRACKET
21	3	9100104	FLAT WASHER
22	3	9313054	SETSCREW
23	3	9143004	SELF-LOCKING NUT
24	1	1290724	DECAL - V4 ACB WIRING
25	3	8581285	ADAPTOR

Model: PA8000M



V4 ARMREST CONTROLS

Module:
22073.01

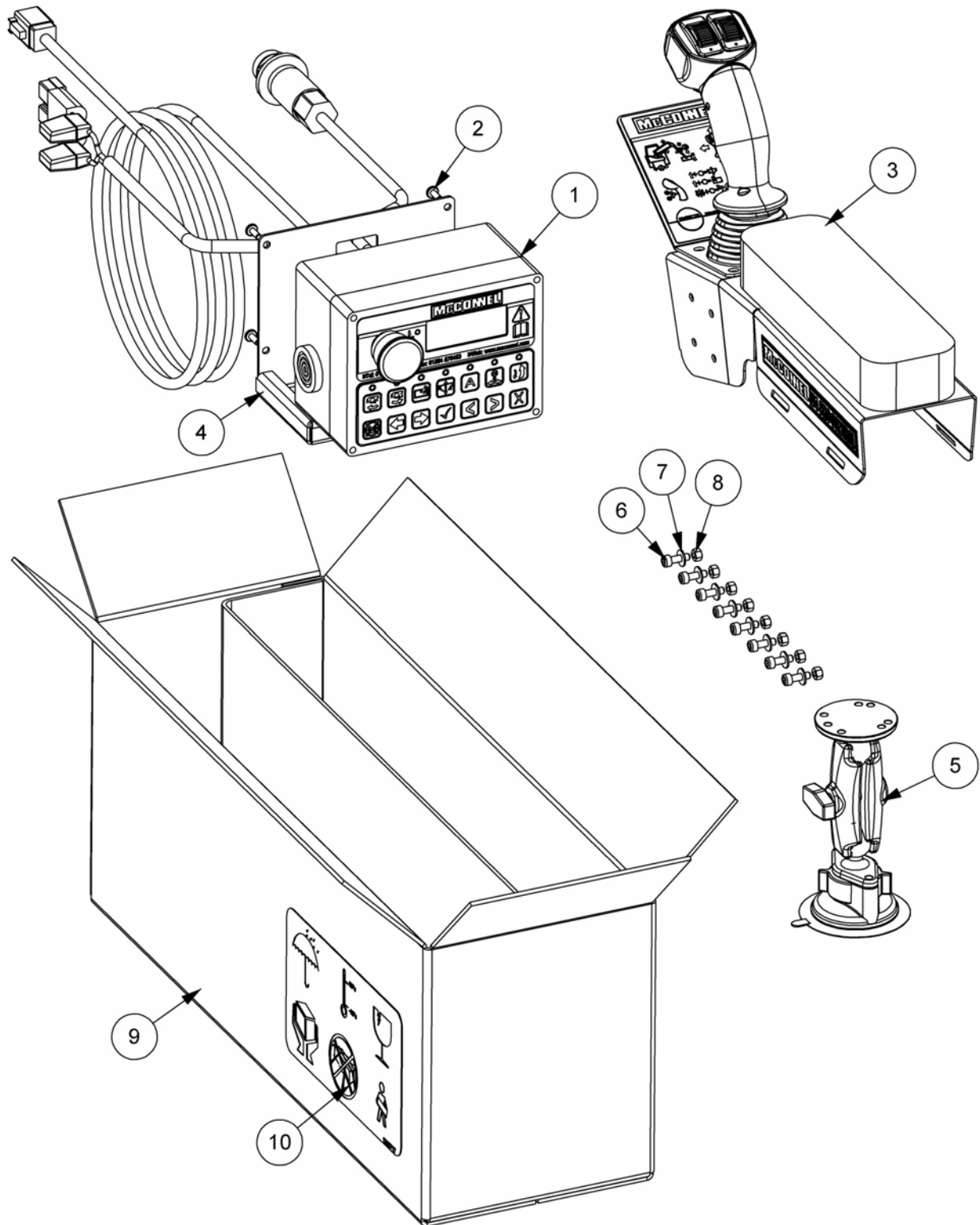



V4 ARMREST CONTROLS

REF.	QTY.	PART No.	DESCRIPTION
		22073.01	V4 CONTROLS WITH JC6000
1	1	22073.14	V4 CONTROL BOX (MK2)
2	4	2800243	SELF TAPPING SCREW
3	1	22073.03	V4 JOYSTICK ARMREST ASSEMBLY
4	1	22073.58	SCREEN MOUNT
5	1	22073.09	V4 SCREEN MOUNT KIT
6	8	9343032	CAPSCREW
7	8	9100102	FLAT WASHER
8	8	9143002	SELF-LOCKING NUT
9	1	8402700	WATER PROOF CARDBOARD BOX
10	1	1290717	BOX DECAL

Model: PA8000M



V4 CONTROL BOX (Mk2)

Module:
22073.14

Signal Lead Connections

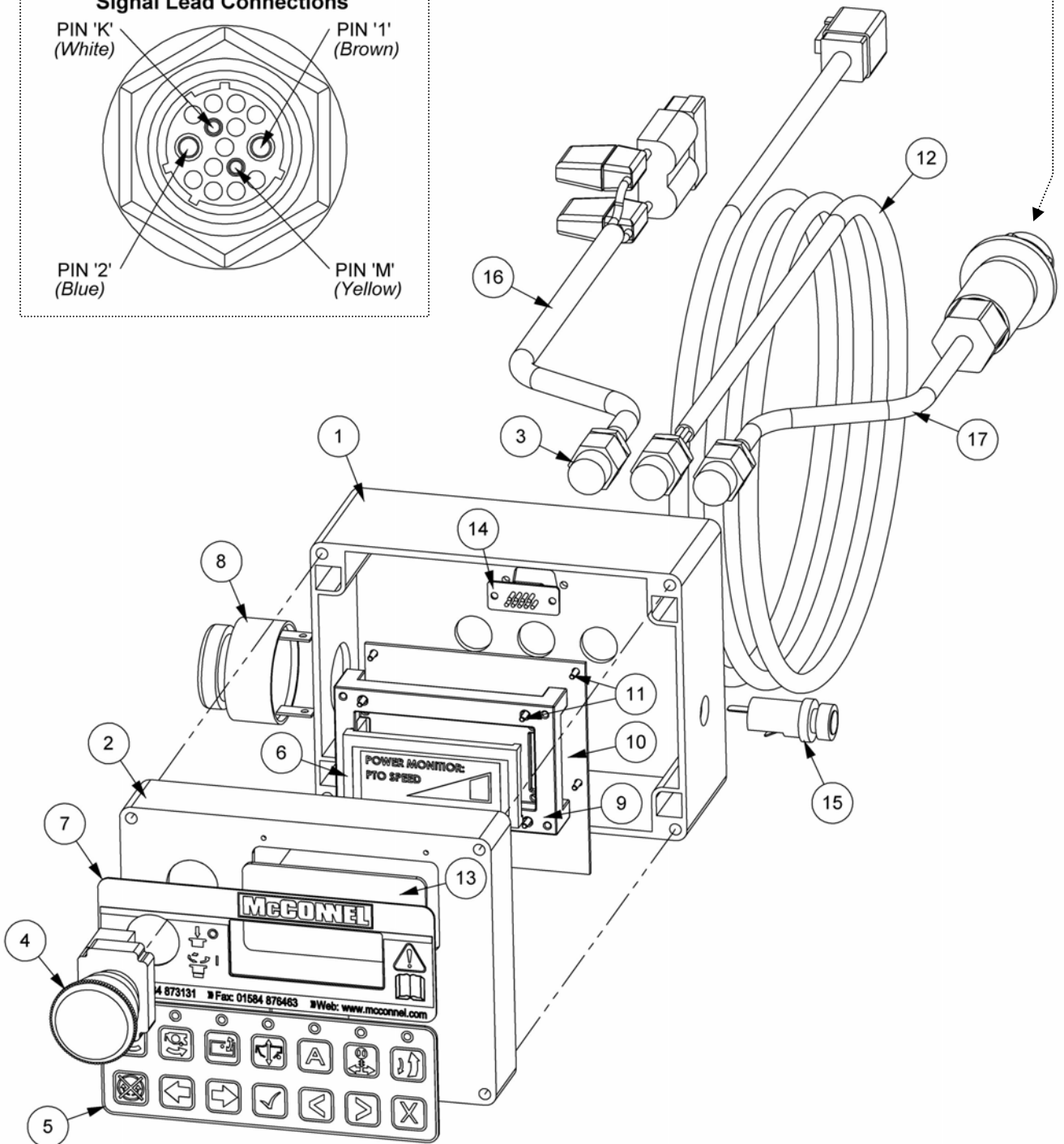
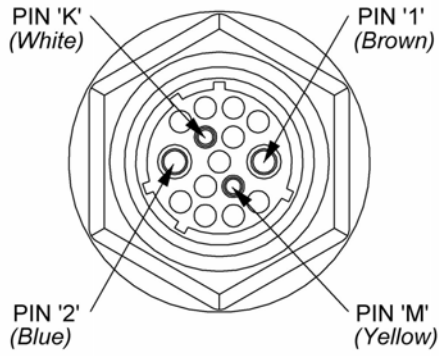

V4 CONTROL BOX (Mk2)

REF.	QTY.	PART No.	DESCRIPTION
		22073.14	V4 CONTROL BOX ASSEMBLY (Mk2)
1	1	22073.62	V4 CONTROL BOX
2	1	22073.32	BOX LID
3	3	8402149	* GLAND (PLASTIC)
4	1	41786.33	SWITCH / EMERGENCY STOP
5	1	22073.34	V4 KEY PAD
6	1	43022.52	* LCD SCREEN
7	1	22073.35	V4 DECAL
8	1	22073.37	* SPEAKER
9	1	22073.39	V4 SCREEN MOUNT
10	1	22073.38	V4 PCB
11	8	22073.42	SELF-TAPPING SCREW
12	1	22073.36	* LOOM
13	1	22073.40	SCREEN COVER
14	1	43022.39	* CONNECTOR (9 WAY)
15	1	22073.41	FUSE HOLDER - BAYONET CAP (10A)
16	1	22073.60	* TWIN CORE POWER LOOM
17	1	22073.61	* CONTROL BOX SIGNAL LEAD

* *Factory replacement items only*

SLEW RAM ASSEMBLY

Module:
43316.03

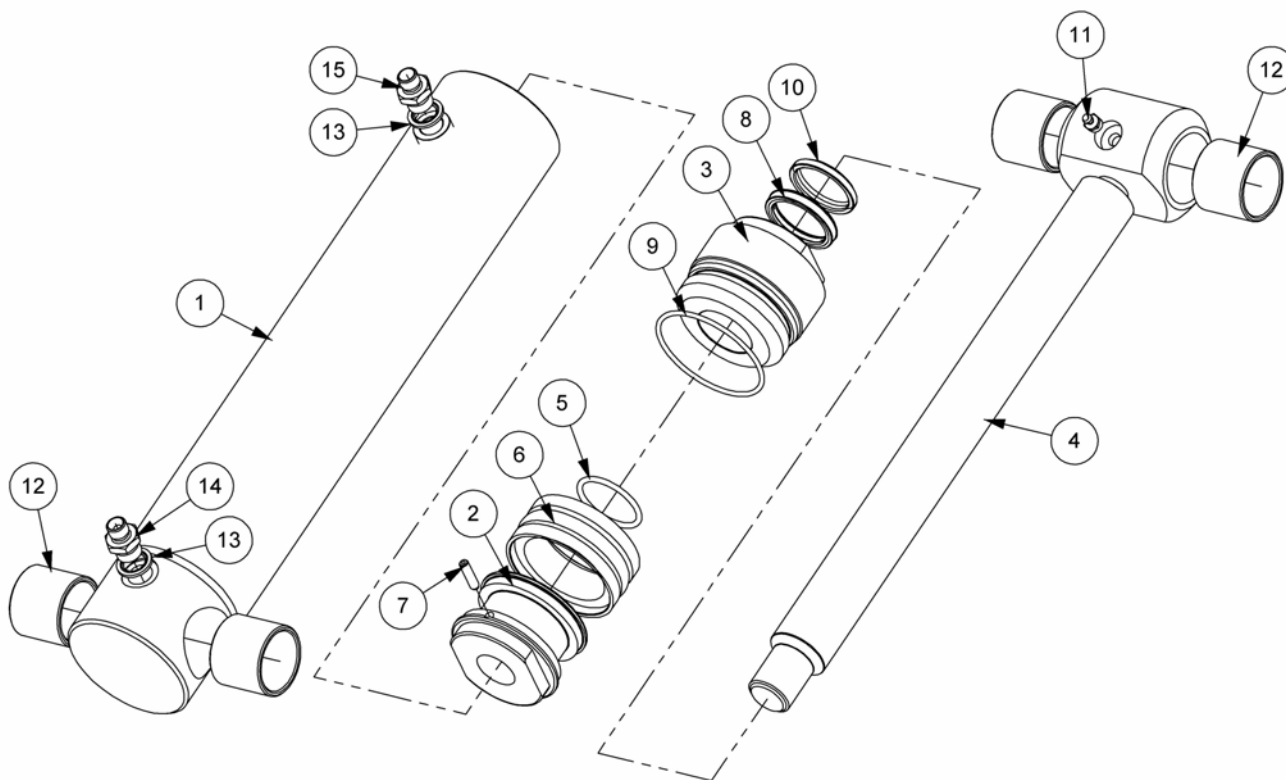

REF.	QTY.	PART No.	DESCRIPTION
		43316.03	SLEW RAM ASSEMBLY
1	1	43316.36	RAM BARREL
2	1	43316.31	PISTON
3	1	43316.32	GLAND HOUSING
4	1	43316.33	PISTON ROD
5	1	8600301	O RING
6	1	8638740	PISTON SEAL
7	1	42775.01	DOWEL
8	1	8629225	GLAND SEAL
9	1	8700740	O RING
10	1	8629208	SCRAPER RING
11	1	0901121	GREASE NIPPLE
12	4	08.297.02	BUSH
13	2	8650103	BONDED SEAL
14	1	8581145	ADAPTOR
15	1	8130066	RESTRICTOR
		43316.01	SEAL KIT

1st RAM ASSEMBLY (LIFT)

Module:
21645.02

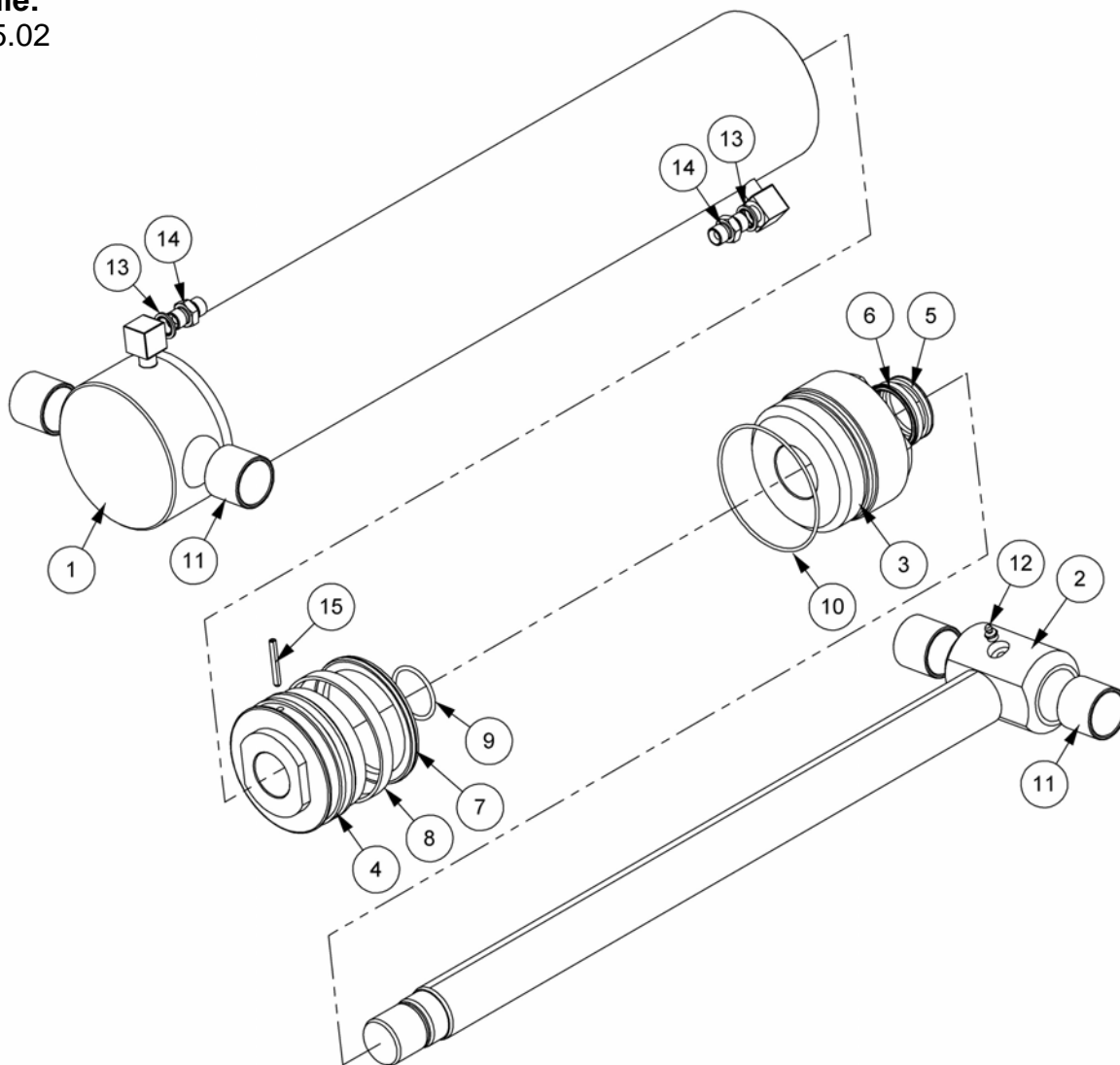

REF.	QTY.	PART No.	DESCRIPTION
		21645.02	HYDRAULIC RAM ASSEMBLY
1	1	21645.36	BARREL (120mm BORE)
2	1	21645.33	ROD (Ø50mm)
3	1	21645.31	GLAND HOUSING
4	1	21136.31	PISTON
5	1	8629227	SEAL
6	1	8629184	SEAL
7	1	8629235	PISTON SEAL
8	1	8629236	GUIDE RING
9	1	8600302	O RING
10	1	8700748	O RING
11	4	08.297.02	BUSH
12	1	0901121	GREASE NIPPLE
13	2	8650103	BONDED SEAL
14	2	6000113	ADAPTOR
15	1	42775.02	DOWEL PIN
		21645.01	SEAL KIT

Model: PA8000M



2nd RAM ASSEMBLY (LIFT)

Module:
21646.02

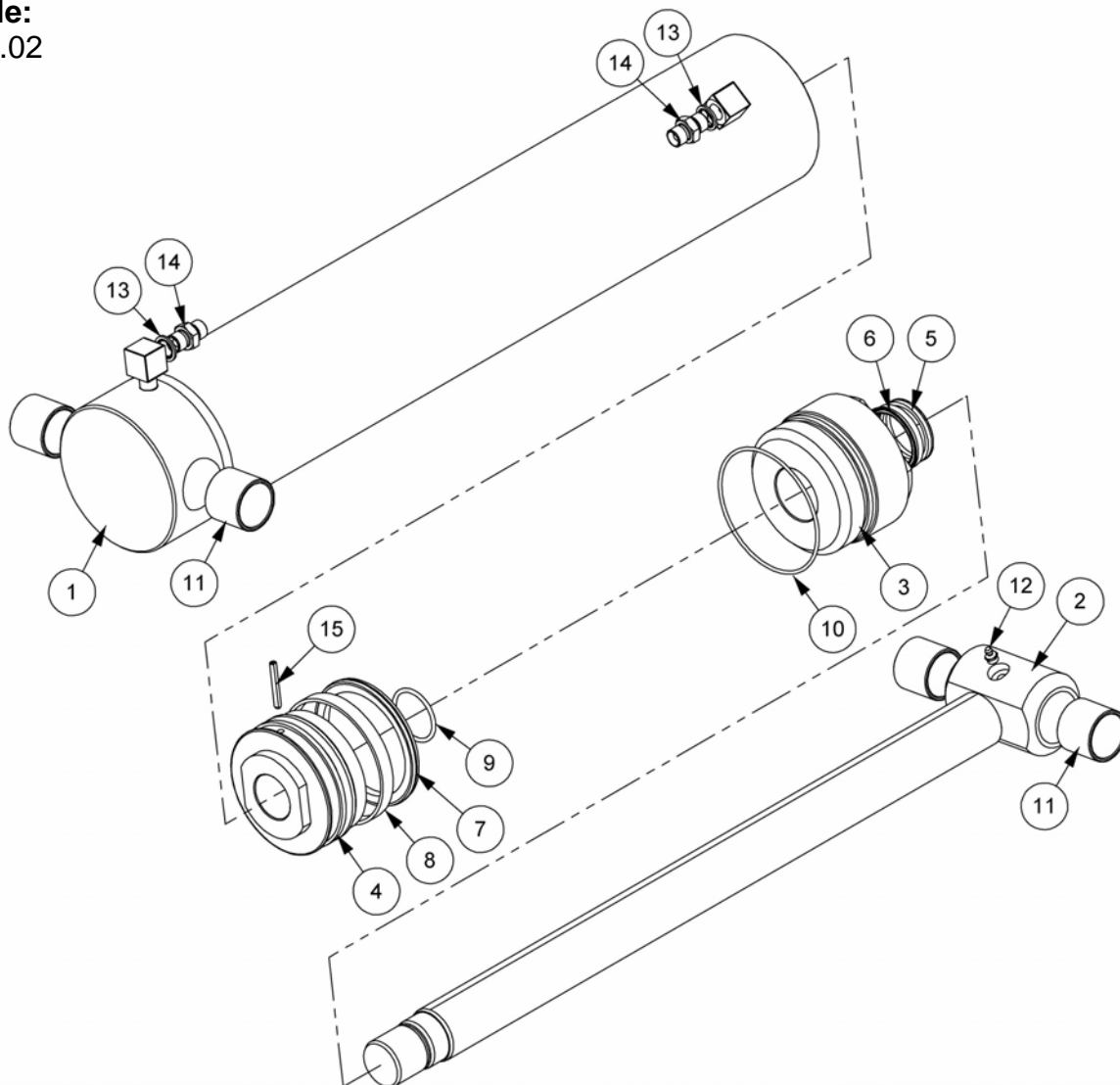

REF.	QTY.	PART No.	DESCRIPTION
		21646.02	HYDRAULIC RAM ASSEMBLY
1	1	21646.34	BARREL (120mm BORE)
2	1	21646.32	ROD (Ø50mm)
3	1	21645.31	GLAND HOUSING
4	1	21136.31	PISTON
5	1	8629227	SEAL
6	1	8629184	SEAL
7	1	8629235	PISTON SEAL
8	1	8629236	GUIDE RING
9	1	8600302	O RING
10	1	8700748	O RING
11	4	08.297.02	BUSH
12	1	0901121	GREASE NIPPLE
13	2	8650103	BONDED SEAL
14	2	6000113	ADAPTOR
15	1	42775.02	DOWEL PIN
		21645.01	SEAL KIT

3rd RAM ASSEMBLY (REACH)

Module:
21654.02

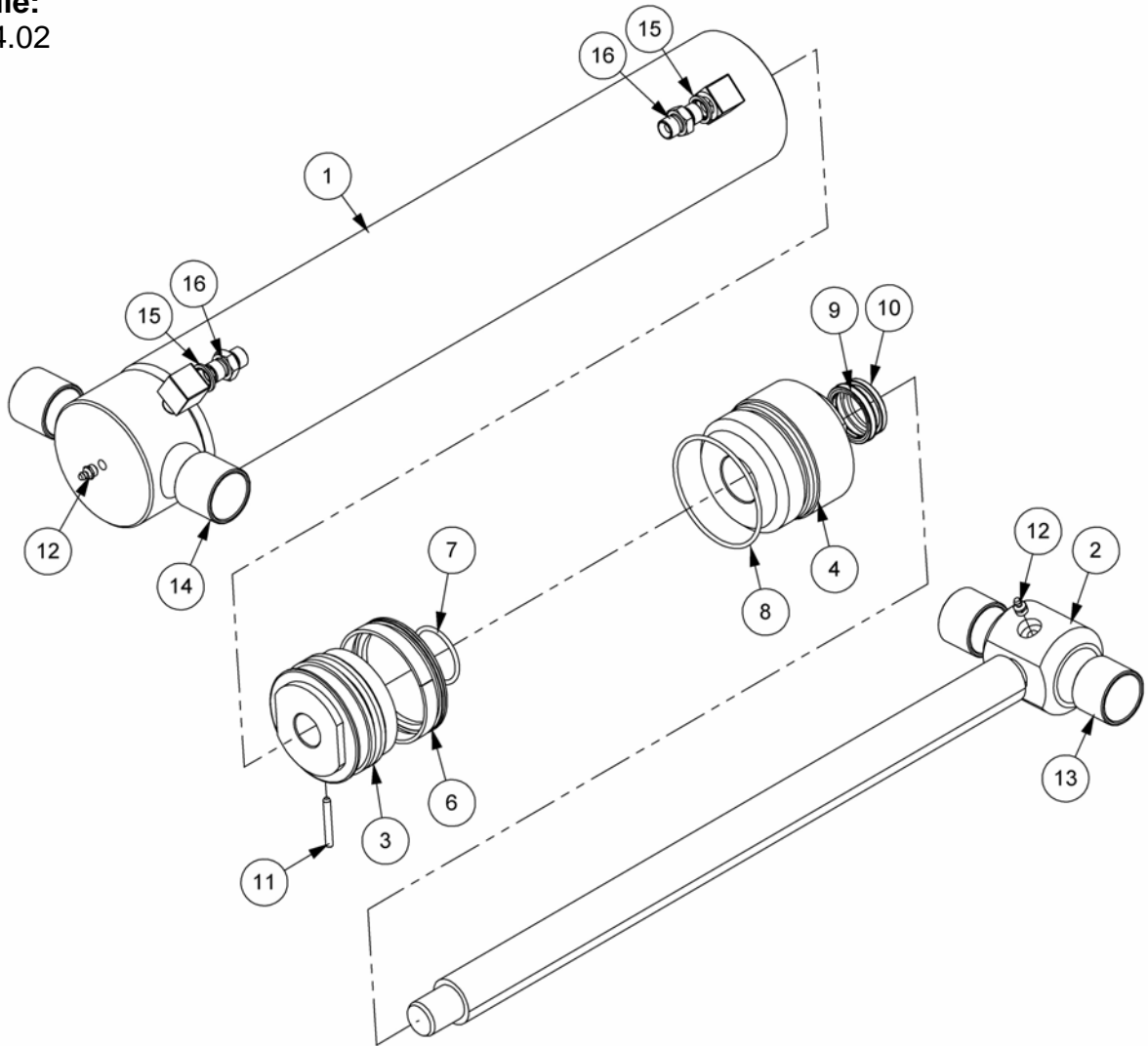

REF.	QTY.	PART No.	DESCRIPTION
		21654.02	HYDRAULIC RAM ASSEMBLY
1	1	21654.33	BARREL (100mm BORE)
2	1	21654.32	ROD (Ø40mm)
3	1	21654.36	PISTON
4	1	21654.38	GLAND HOUSING
5	1	8629182	PISTON SEAL
6	1	8629183	BEARING RING
7	1	8600302	O RING
8	1	8600317	O RING
9	1	8629225	GLAND SEAL
10	1	8629208	SCRAPER RING
11	1	42775.02	DOWEL PIN
12	2	0901121	GREASE NIPPLE
13	2	21654.39	BUSH
14	2	08.297.02	BUSH
15	2	8650103	BONDED SEAL
16	2	6000113	ADAPTOR
		21654.01	SEAL KIT

Model: PA8000M



ANGLING RAM ASSEMBLY

Module:
43317.07

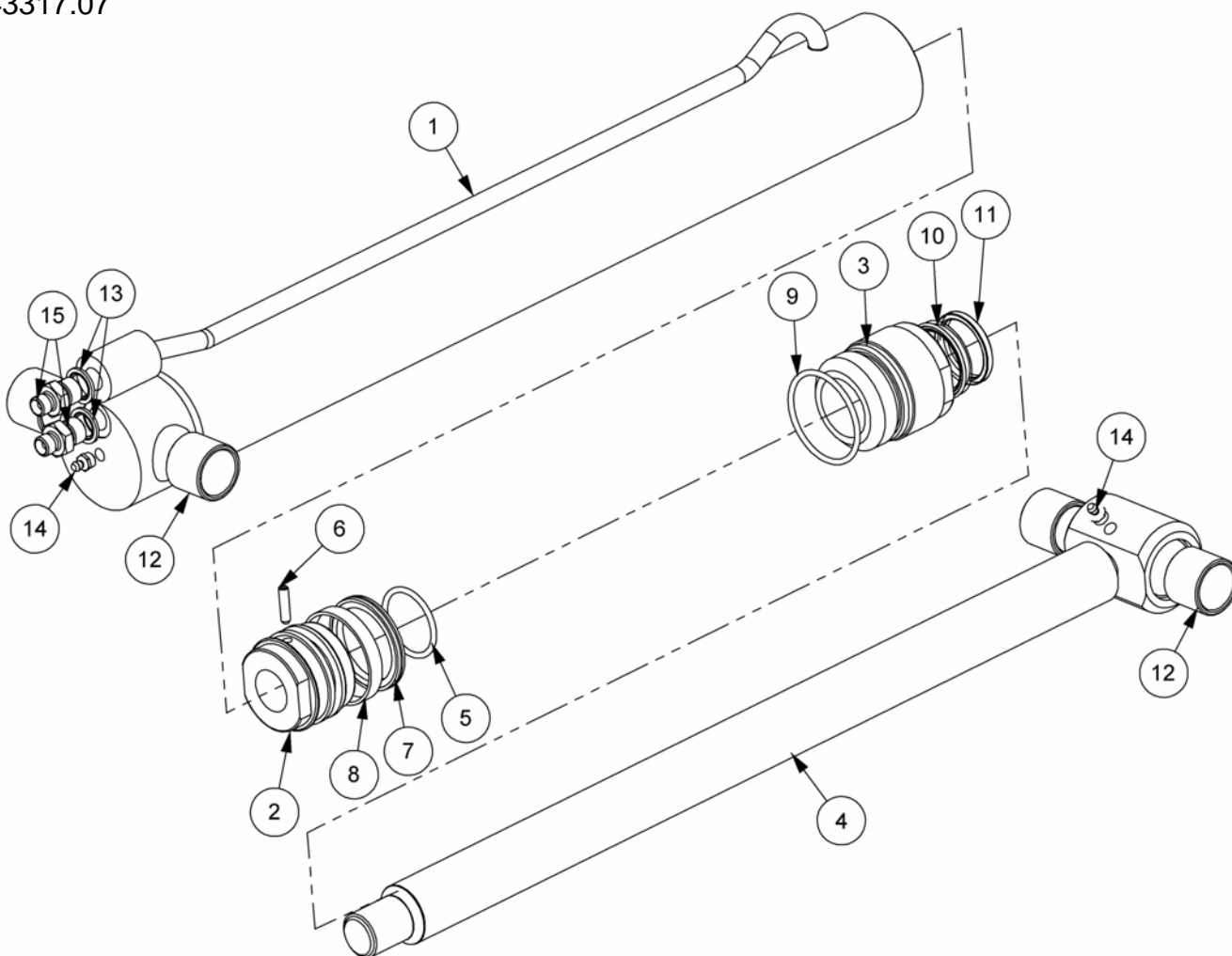

REF.	QTY.	PART No.	DESCRIPTION
		43317.07	ANGLING RAM ASSEMBLY
1	1	43317.33	BARREL
2	1	43317.31	PISTON
3	1	43317.32	GLAND HOUSING
4	1	43317.35	PISTON ROD
5	1	8600301	O RING
6	1	42775.01	DOWEL
7	1	8629156	PISTON SEAL
8	1	8629157	PISTON GUIDE RING
9	1	8600306	O RING
10	1	8629225	ROD GLAND SEAL
11	1	8629208	ROD SCRAPER RING
12	4	08.297.04	BUSH
13	2	8650103	BONDED SEAL
14	2	0901121	GREASER
15	2	8581115	ADAPTOR
		43317.01	SEAL KIT

CHARGE FILTER ASSEMBLY

Module:
42782.04

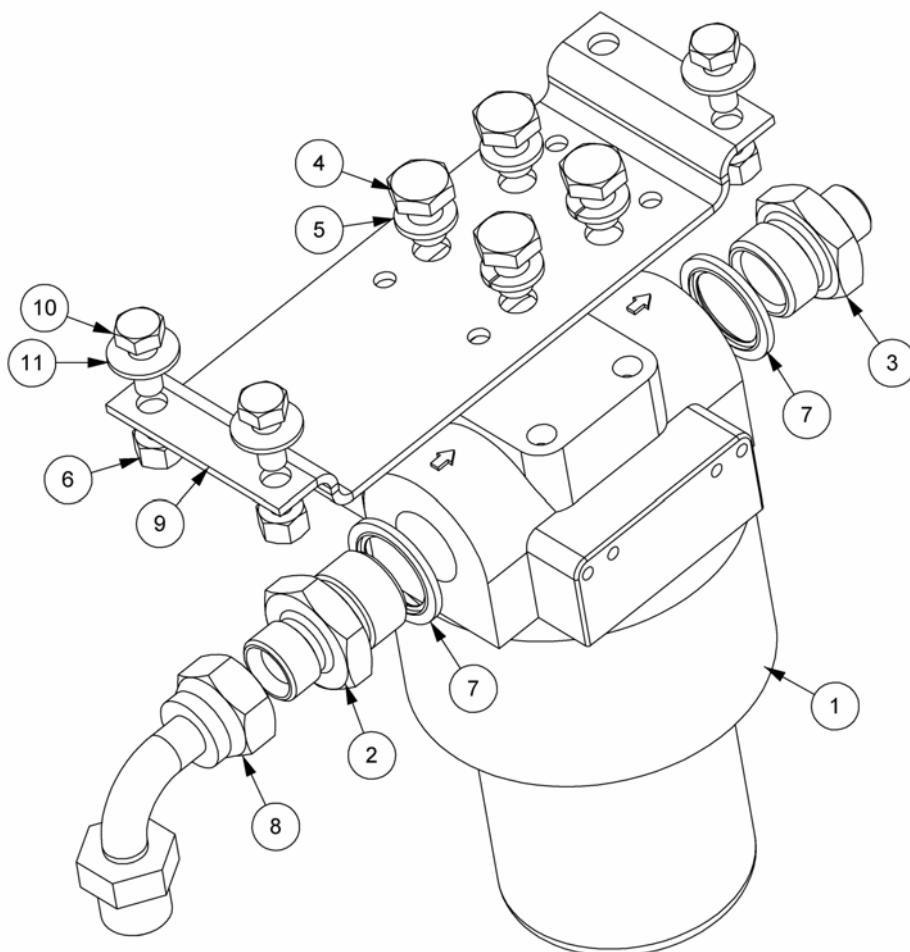

REF.	QTY.	PART No.	DESCRIPTION
		42782.04	CHARGE FILTER ASSEMBLY
1	1	8401084	FILTER (10MIC)
2	1	8581130	ADAPTOR
3	1	8581131	ADAPTOR
4	4	9313035	SETSCREW
5	4	9100205	SPRING WASHER
6	3	9143004	SELF-LOCKING NUT
7	2	8650106	BONDED SEAL
8	1	8581215	SWEPT ADAPTOR - 90°
9	1	43388.34	CHARGE FILTER BRACKET
10	3	9313044	SETSCREW
11	3	9100104	FLAT WASHER

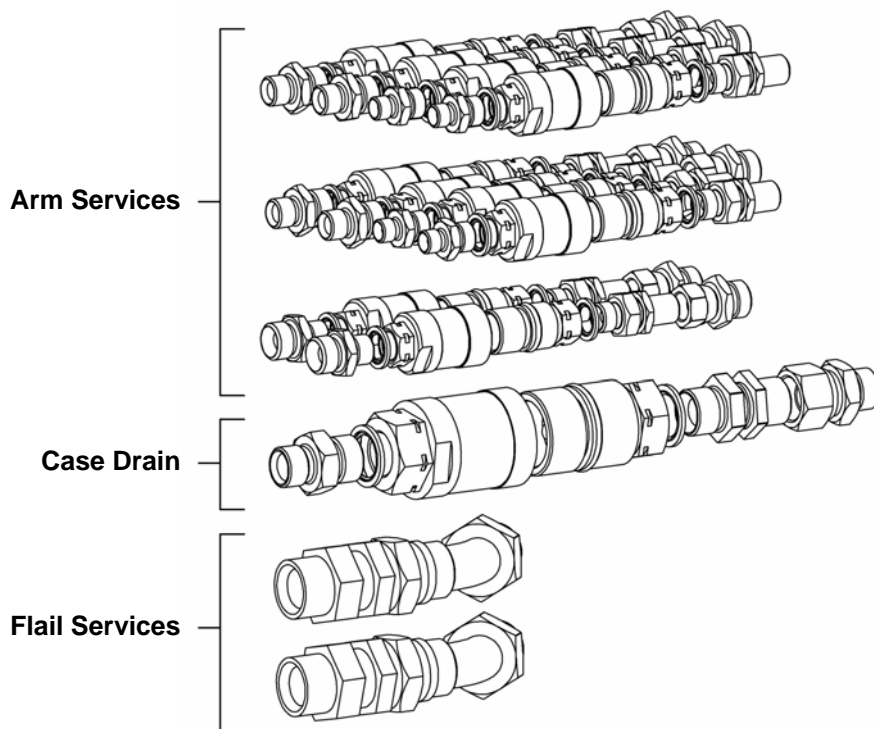
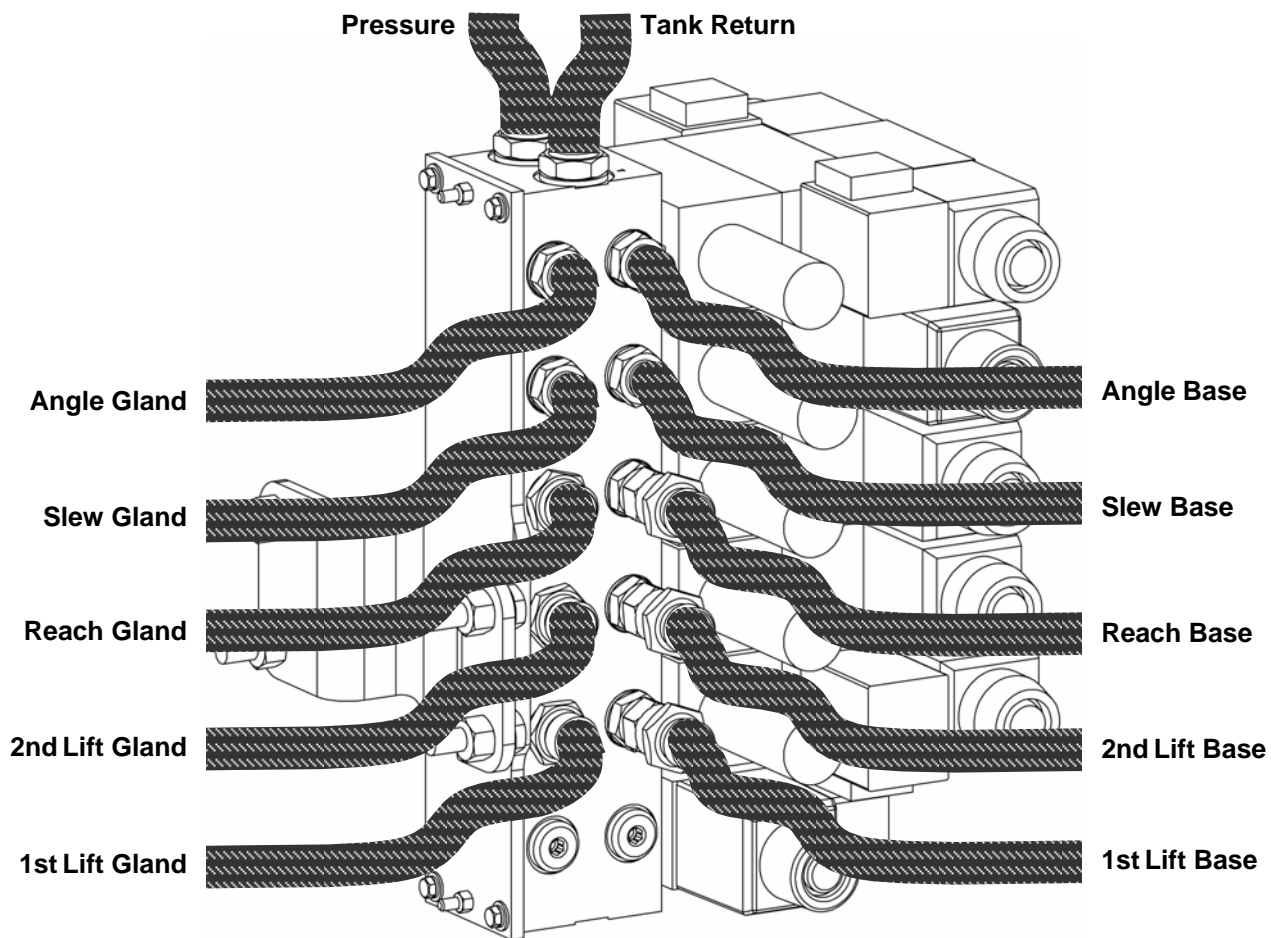



FRAME HOSE KIT

REF.	QTY.	PART No.	DESCRIPTION
		77807162	FRAME HOSE KIT - PA8000M
1	2	21270.10	HOSE - 1" BSP FS/F135 x 500mm
2	1	10.007.29	HOSE - 5/8" BSP FS/FS x 1900mm
3	1	10.008.13	HOSE - 5/8" BSP FS/F90 x 650mm
4	1	10.008.17	HOSE - 5/8" BSP FS/F90 x 850mm
5	1	10.003.17	HOSE - 3/8" BSP FS/FS x 850mm
6	1	10.012.22	HOSE - 1" BSP FS/F90 x 1200mm
7	1	10.008.20	HOSE - 5/8" BSP FS/F90 x 1000mm
8	1	10.006.20	HOSE - 1/2" BSP FS/F90 x 1000mm
9	1	10.006.21	HOSE - 1/2" BSP FS/F90 x 1100mm
10	1	10.004.21	HOSE - 3/8" BSP FS/F90 x 1100mm
11	6	10.005.24	HOSE - 1/2" BSP FS/FS x 1400mm
12	3	10.005.23	HOSE - 1/2" BSP FS/FS x 1300mm
13	2	10.001.24	HOSE - 1/4" BSP ST/ST x 1400mm
14	2	10.001.25	HOSE - 1/4" BSP FS/FS x 1500mm
15	1	10.005.06	HOSE - 1/2" BSP FS/FS x 300mm

HOSE LOCATION

- | | |
|---------------------------------------|--------------------------------|
| 1 Flail Pump to Bulkhead | 10 Charge Filter to Pump Valve |
| 2 Motor Case Drain - Bulkhead to Tank | 11 1st Ram - Valve to Bulkhead |
| 3 1st Pump Case Drain - Pump to Tank | 2nd Ram - Valve to Bulkhead |
| 4 2nd Pump Case Drain - Pump to Tank | 1st Ram - Bulkhead to Tap |
| 5 2nd Pump Case Drain - Pump to Tank | 12 3rd Ram - Valve to Bulkhead |
| 6 Cooler to Tank | 1st Ram - Tap to Valve |
| 7 Valve to Cooler | 13 Slew - Valve to Bulkhead |
| 8 Control Pump to Valve | 14 Angle - Valve to Bulkhead |
| 9 Pump to Charge Filter | 15 1st Ram - Tap to Tank |

NOTE: Hose positioning has been carefully calculated to avoid risk of pinching, stretching and chaffing - it is advisable when replacing hoses to run the new one alongside the old one prior to removal in order to determine the correct routing. For identification purposes part numbers of the hoses are marked on their connection ends.

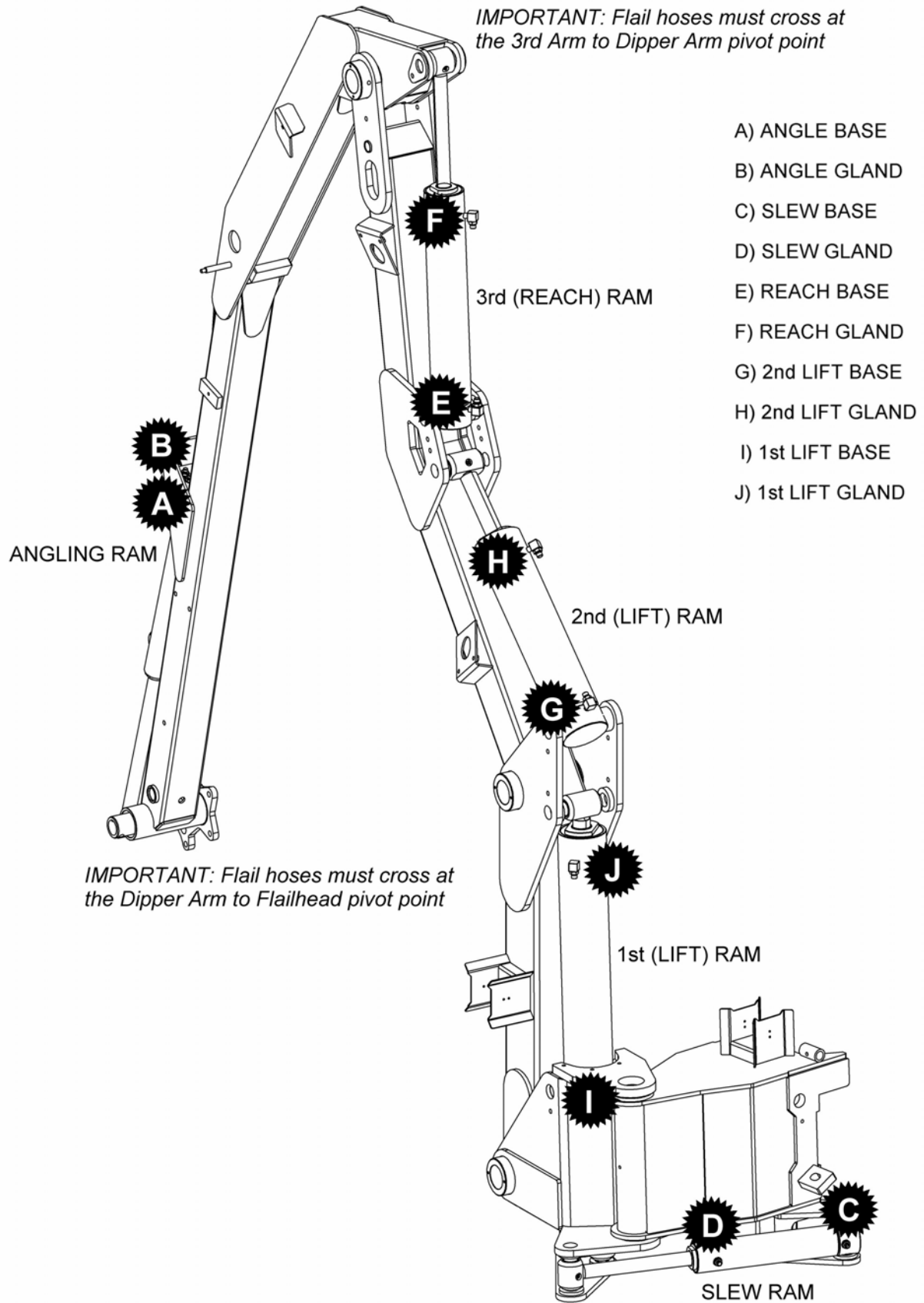



ARM HOSE KIT

REF.	QTY.	PART No.	DESCRIPTION
		77807172	ARM HOSE KIT - PA8000M
1	2	21270.16	HOSE - 1" BSP FS/F135 x 800mm
2	2	21269.20	HOSE - 1" BSP FS/FS x 1000mm
3	2	21268.20	HOSE - 1" BSP FS/F90 x 1000mm
4	2	21269.43	HOSE - 1" BSP FS/FS x 3300mm
5	2	21269.89	HOSE - 1" BSP FS/FS x 7900mm
6	1	10.008.38	HOSE - 5/8" BSP FS/F90 x 2800mm
7	1	10.008.20	HOSE - 5/8" BSP FS/F90 x 1000mm
8	1	10.007.43	HOSE - 5/8" BSP FS/FS x 3300mm
9	1	10.007.89	HOSE - 5/8" BSP FS/FS x 7900mm
10	2	10.002.45	HOSE - 1/4" BSP FS/F90 x 3500mm
11	4	10.002.13	HOSE - 1/4" BSP FS/F90 x 650mm
12	2	10.001.49	HOSE - 1/4" BSP FS/FS x 3900mm
13	2	10.001.85	HOSE - 1/4" BSP FS/FS x 7500mm
14	1	10.005.93	HOSE - 1/2" BSP FS/FS x 8300mm
15	1	10.005.92	HOSE - 1/2" BSP FS/FS x 8200mm
16	2	10.005.87	HOSE - 1" BSP FS/FS x 7700mm
17	1	10.005.80	HOSE - 1/2" BSP FS/FS x 7000mm
18	1	10.005.79	HOSE - 1/2" BSP FS/FS x 6900mm
19	1	10.001.50	HOSE - 1/4" BSP FS/FS x 4000mm
20	1	10.001.52	HOSE - 1/4" BSP FS/FS x 4200mm
21	2	10.002.13	HOSE - 1/4" BSP FS/F90 x 650mm

HOSE LOCATION

- | | |
|--|-------------------------------------|
| 1 Flailhead - Motor to Steel Pipe | 12 Angle Ram - Solenoid to Main Arm |
| 2 Flailhead - Steel Pipe to Bulkhead | 13 Angle Ram - Main Arm to Frame |
| 3 Flailhead - Bulkhead to Turntable Solenoid Bracket | 14 3rd Ram - Gland to Frame |
| 4 Flail Circuit - Dipper Arm to Main Arm | 15 3rd Ram - Base to Frame |
| 5 Flail Circuit - Main Arm to Frame | 16 2nd Ram - Gland & Base to Frame |
| 6 Case Drain - Flailhead to Bracket | 17 1st Ram - Gland to Frame |
| 7 Case Drain - Bracket to Turntable Bracket | 18 1st Ram - Base to Frame |
| 8 Case Drain - Turntable Bracket to Main Arm | 19 Slew Ram - Gland Front to Frame |
| 9 Case Drain - Main Arm to Frame | 20 Slew Ram - Gland Rear to Frame |
| 10 Turntable - Flailhead to Turntable Bracket | 21 Slew Ram - Base to Gland |
| 11 Angle Ram - Solenoid to Ram Base / Gland | |

NOTE: Hose positioning has been carefully calculated to avoid risk of pinching, stretching and chaffing - it is advisable when replacing hoses to run the new one alongside the old one prior to removal in order to determine the correct routing. For identification purposes part numbers of the hoses are marked on their connection ends.

Model: PA8000M



Q/RELEASE ADAPTOR MODULE

Module:
7780713

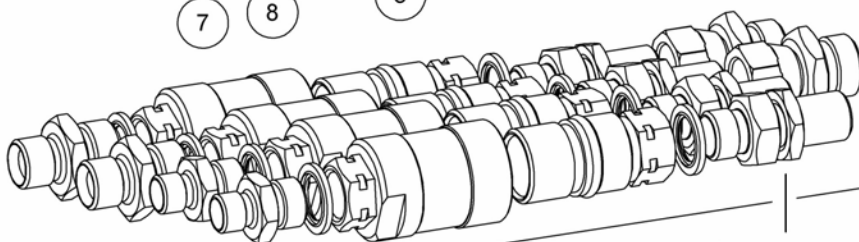
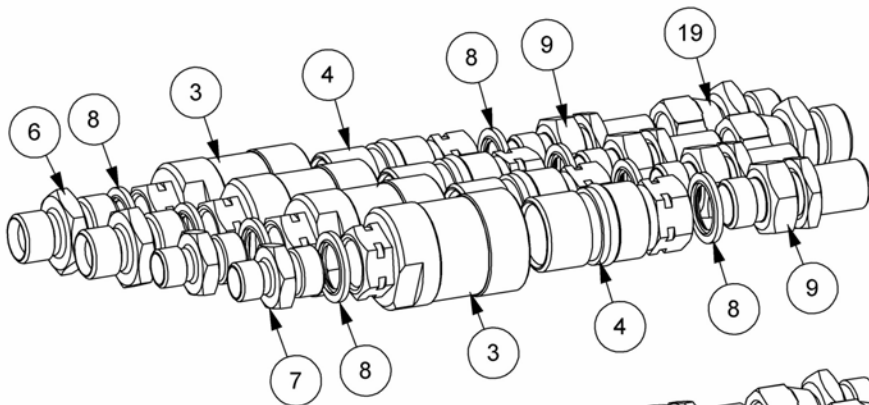

FIT TO BULKHEAD
OF OUTRIGGER
ASSEMBLY 21391.03

HOSES TO ARM ←

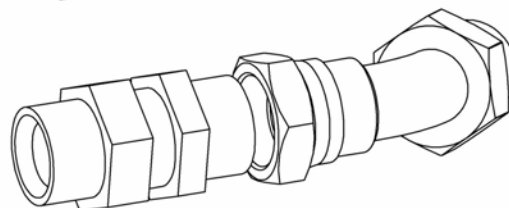
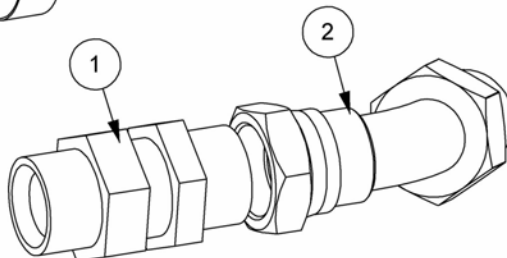
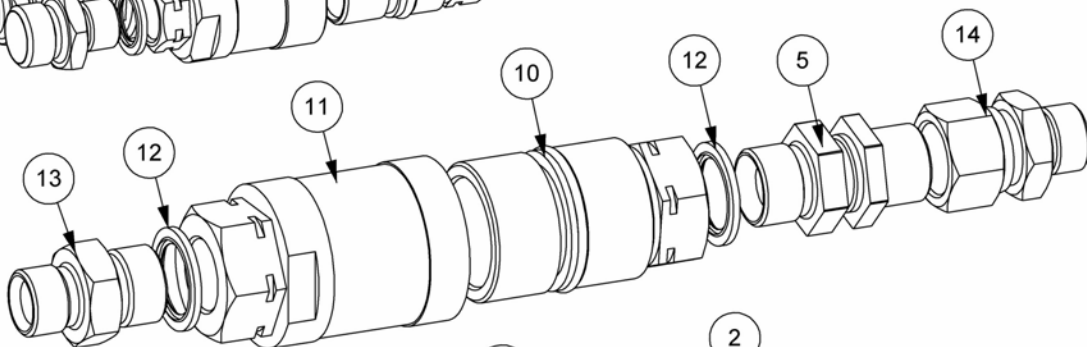
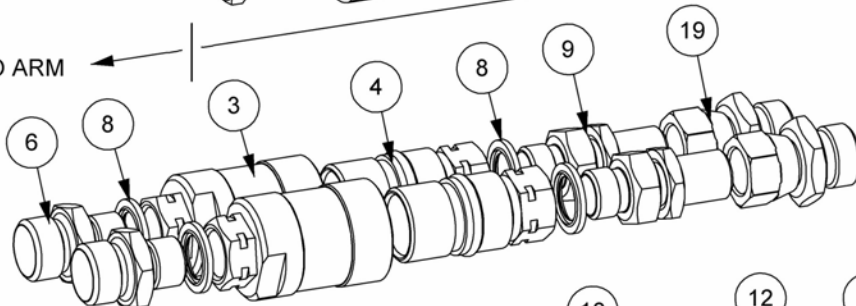

Q/RELEASE ADAPTOR MODULE

REF.	QTY.	PART No.	DESCRIPTION
		7780713	QUICK RELEASE ADAPTOR MODULE
1	2	08.128.03	BULKHEAD FITTING
2	2	08.940.02	ADAPTOR - 135°
3	10	8590183	OUTER COUPLING
4	10	8590173	INNER COUPLING
5	1	T8085	BULKHEAD c/w NUT
6	6	6000112	ADAPTOR
7	4	8581145	ADAPTOR
8	20	8650103	BONDED SEAL
9	10	T8072	BULKHEAD ADAPTOR
10	1	8590176	INNER COUPLING
11	1	8590186	OUTER COUPLING
12	2	8650106	BONDED SEAL
13	1	8581270	ADAPTOR
14	1	8581478	ADAPTOR
15	13	8591173	* DUST CAP
16	13	8591183	* DUST PLUG
17	1	8591176	* DUST CAP
18	1	8591186	* DUST PLUG
19	6	8581285	ADAPTOR

* *not illustrated*

Model: PA8000M

EDS SENSOR MODULE



Module:
7780720

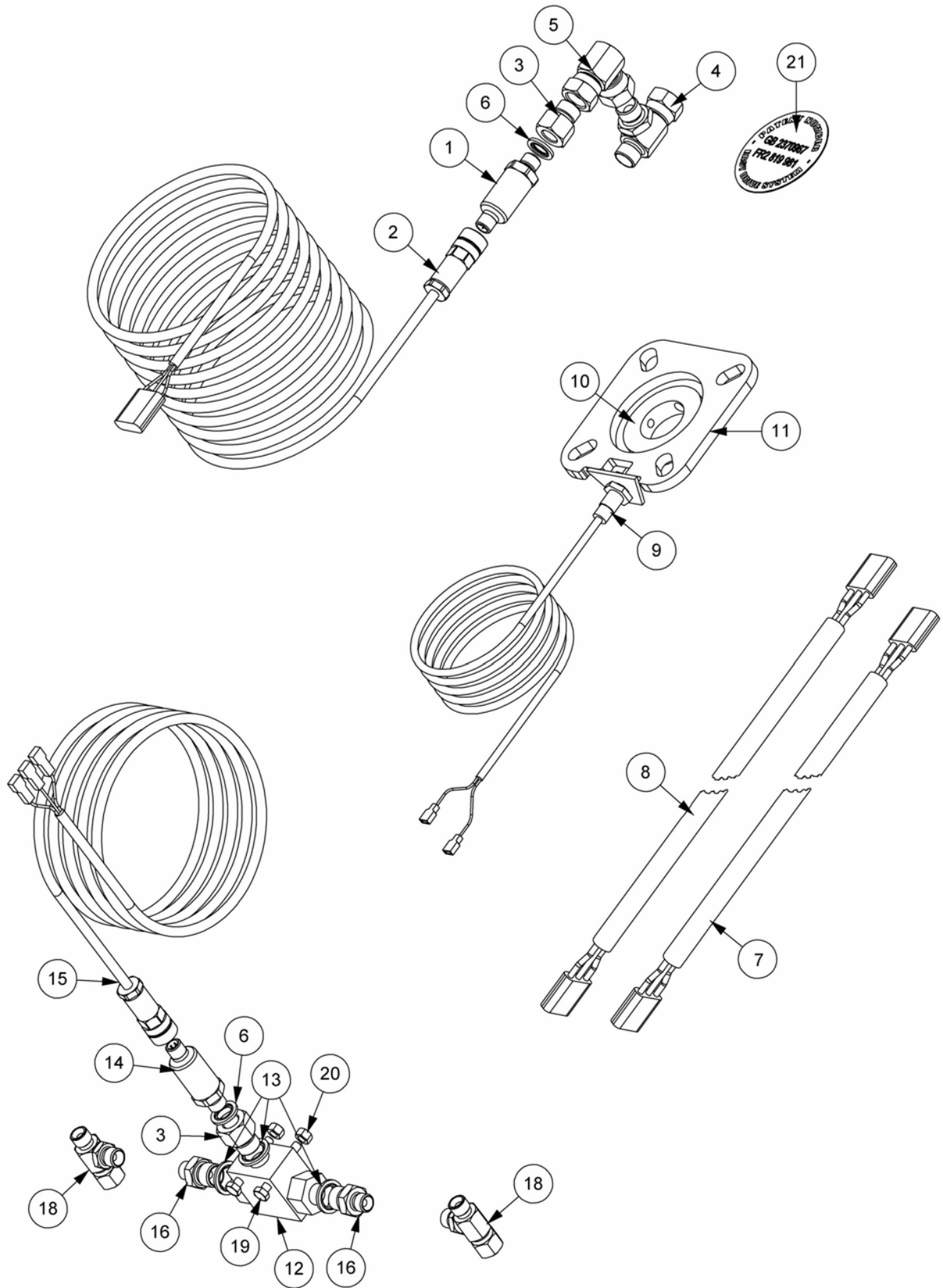

EDS SENSOR MODULE

REF.	QTY.	PART No.	DESCRIPTION
		7780720	EDS SENSOR MODULE
1	1	8402253	PRESSURE SENSOR (0 TO 250 BAR)
2	1	43177.56	LOOM - EDS (BULKHEAD TO SENSOR)
3	2	8103005	ADAPTOR
4	1	11.068.69	ADAPTOR TEE
5	1	8581053	ADAPTOR - 90° SWIVEL
6	2	8650102	BONDED SEAL
7	1	43177.58	LOOM - LIFT SENSOR
8	1	43177.59	LOOM - REACH SENSOR
9	1	Default	PTO SENSOR
10	1	8402252	PTO MAGNETIC RING
11	1	21208.01	BACKING PLATE
12	1	09.820.01	SHUTTLE VALVE
13	3	8650103	BONDED SEAL
14	1	8402254	PRESSURE SENSOR (0 TO 400 BAR)
15	1	43177.52	LOOM - PRESSURE TRANSDUCER
16	2	8581115	ADAPTOR
17	2	10.002.04	HOSE - 1/4" BSP FS/F90 x 200mm
18	2	8581254	ADAPTOR TEE
19	2	30.068.88	BOLT
20	2	9143003	SELF-LOCKING NUT
21	1	21365.01	PATENT DECAL

Model: PA8000M



COOLER ASSEMBLY

Module:
7780732

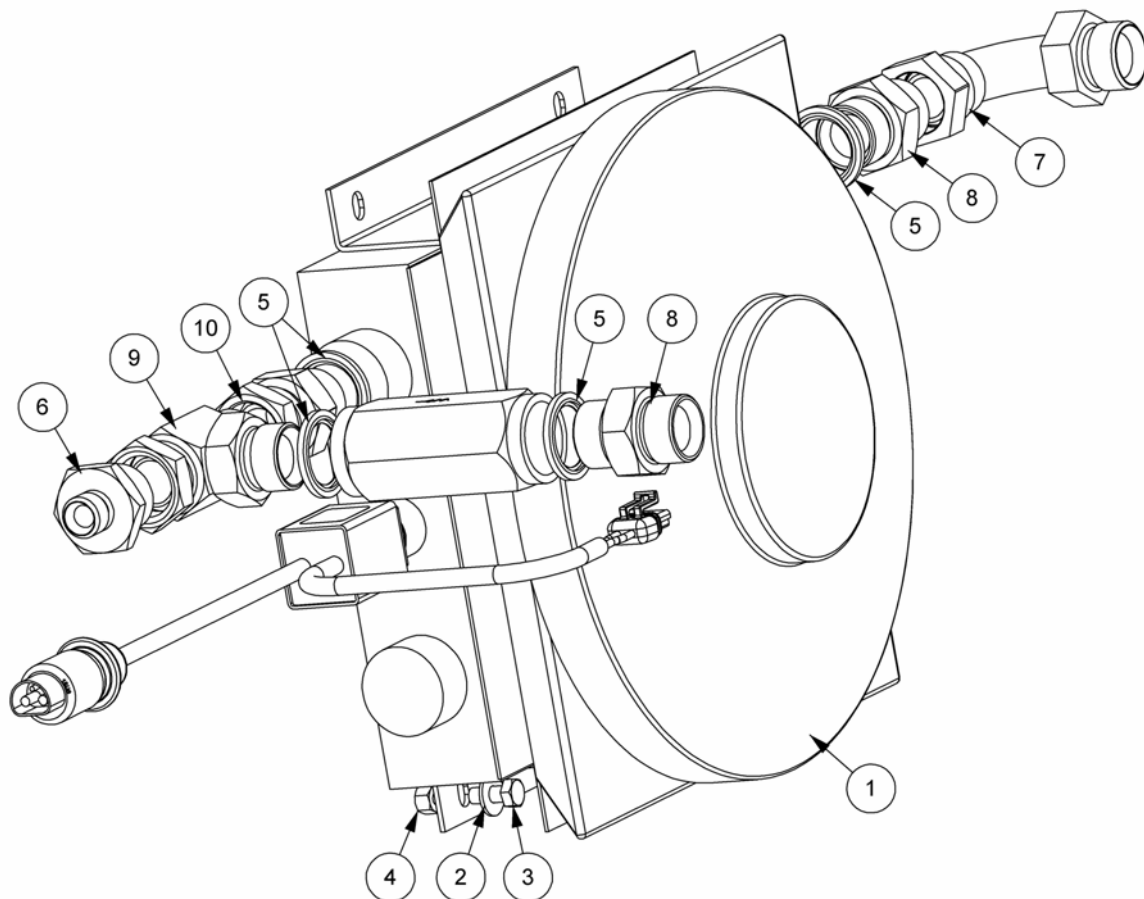

REF.	QTY.	PART No.	DESCRIPTION
		7780732	COOLER ASSEMBLY
1	1	8402379	COOLER c/w THERMO SWITCH AND LOOM
2	2	9100104	FLAT WASHER
3	2	9313044	SETSCREW
4	2	9143004	SELF-LOCKING NUT
5	4	8650108	BONDED SEAL
6	1	8581129	ADAPTOR
7	1	8581264	ADAPTOR - SWEPT 90°
8	2	05.434.01	ADAPTOR
9	1	04.056.02	SWIVEL TEE
10	1	02.714.15	ADAPTOR
11	1	06.282.03	CHECK VALVE

COVER ASSEMBLY

Module:
7780704

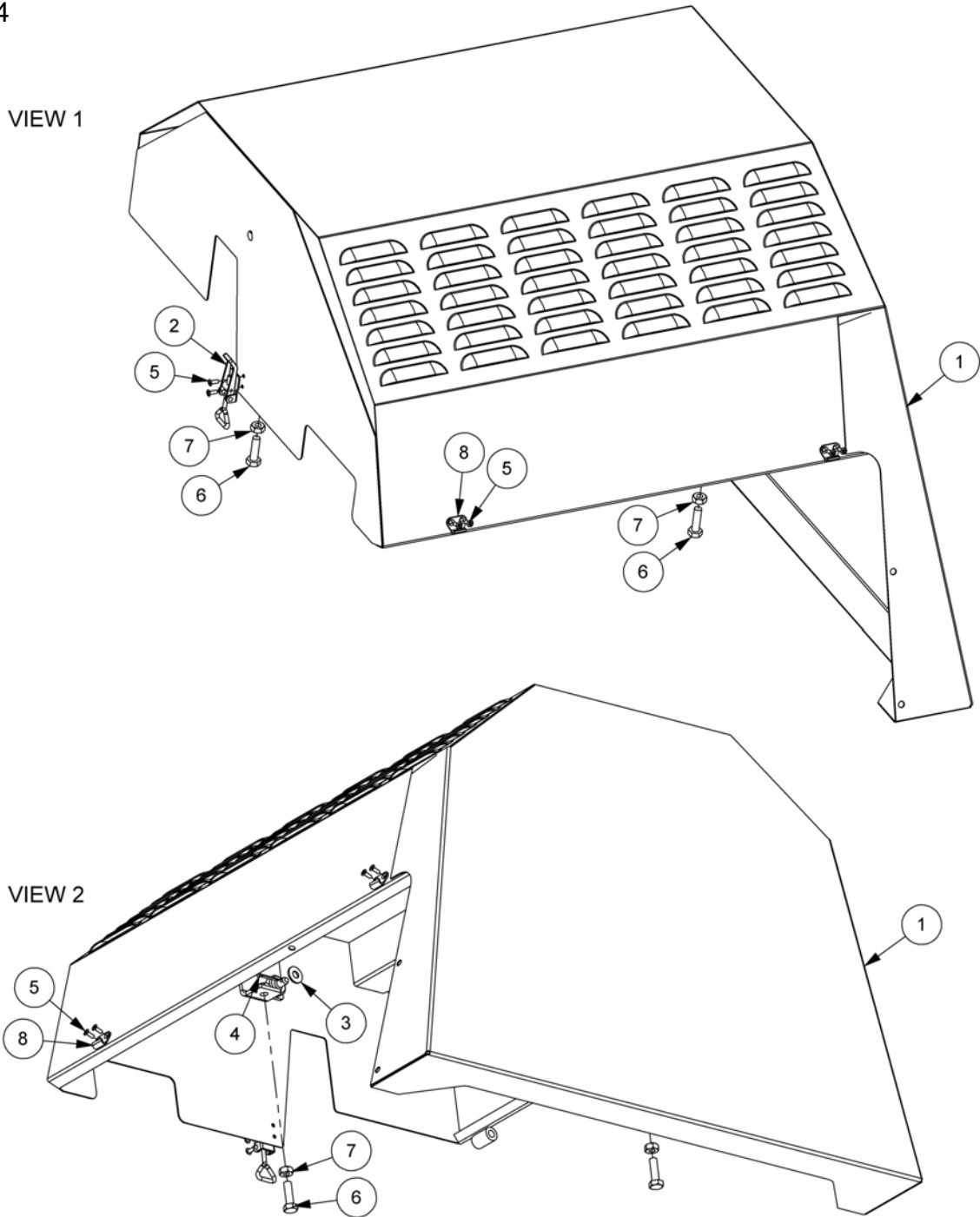

REF.	QTY.	PART No.	DESCRIPTION
		7780704	COVER ASSEMBLY - L/H Build
1	1	21417.03	TANK COVER - L/H Build
2	1	43449.02	OVERCENTRE FASTENER
3	1	9100105	FLAT WASHER
4	1	9501255	SPLIT PIN
5	6	1069088	POP RIVET
6	2	9313075	SETSCREW
7	2	9113005	PLAIN NUT
8	2	46007.01	HOOK (OVERCENTRE FASTENER)

Model: PA8000M



REAR FRAME COVER

Module:
7780706

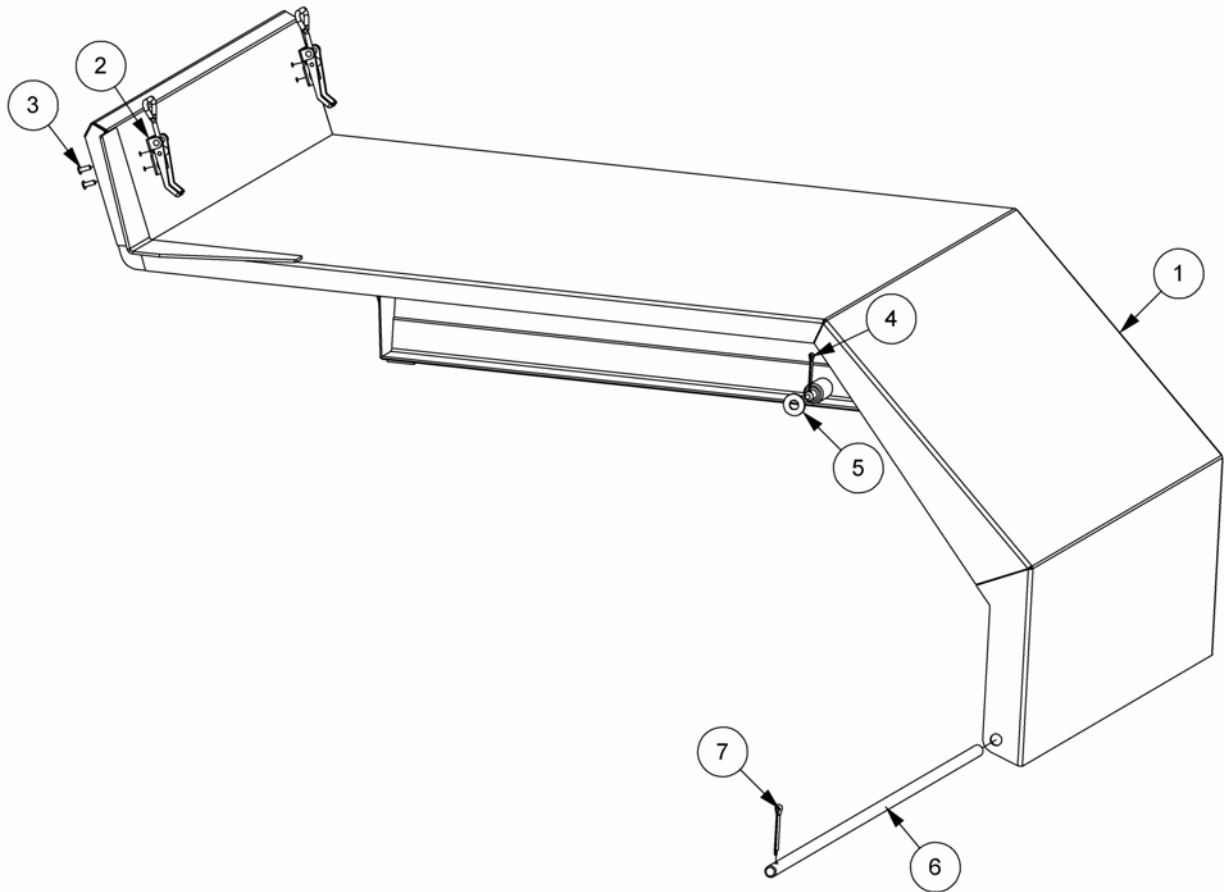

REF.	QTY.	PART No.	DESCRIPTION
		7780706	REAR FRAME COVER - L/H Build
1	1	21433.02	REAR COVER - L/H Build
2	2	43449.02	OVERCENTRE FASTENER
3	4	1069088	POP RIVET
4	1	9501255	SPLIT PIN
5	1	9100105	FLAT WASHER
6	1	21919.01	PIVOT ROD
7	1	9501406	SPLIT PIN

Model: PA8000M



REAR LIGHTING KIT

Module:
45656.07

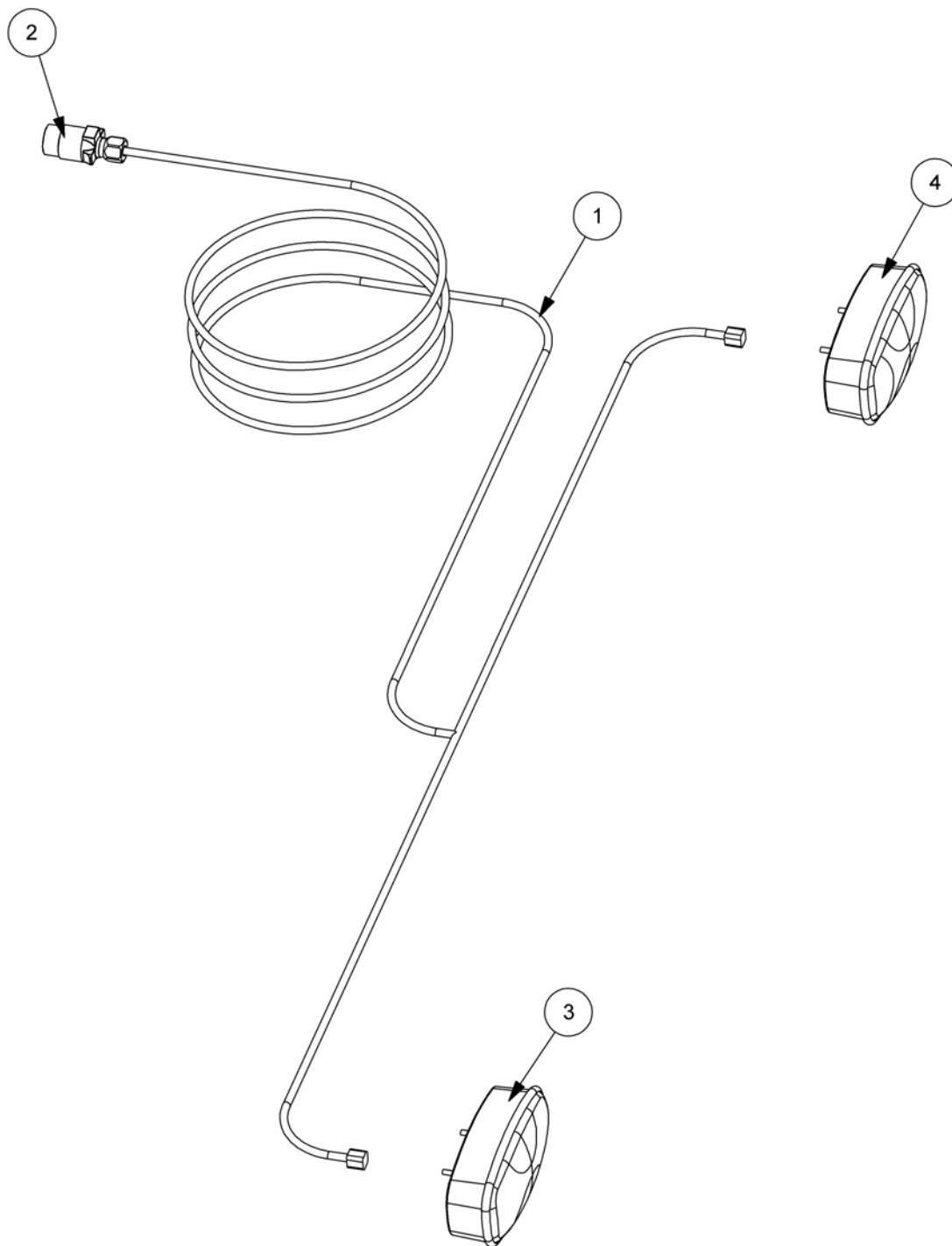

REF.	QTY.	PART No.	DESCRIPTION
		45656.07	REAR LIGHTING KIT
1	1	45656.37	HARNESS - 7 CORE
2	1	7560089	7 PIN PLUG
3	1	21392.01	REAR LAMP - L/H
4	1	21392.02	REAR LAMP - R/H

Model: PA8000M

AXLE LOCKING KIT – MF6475



Module:
7780736

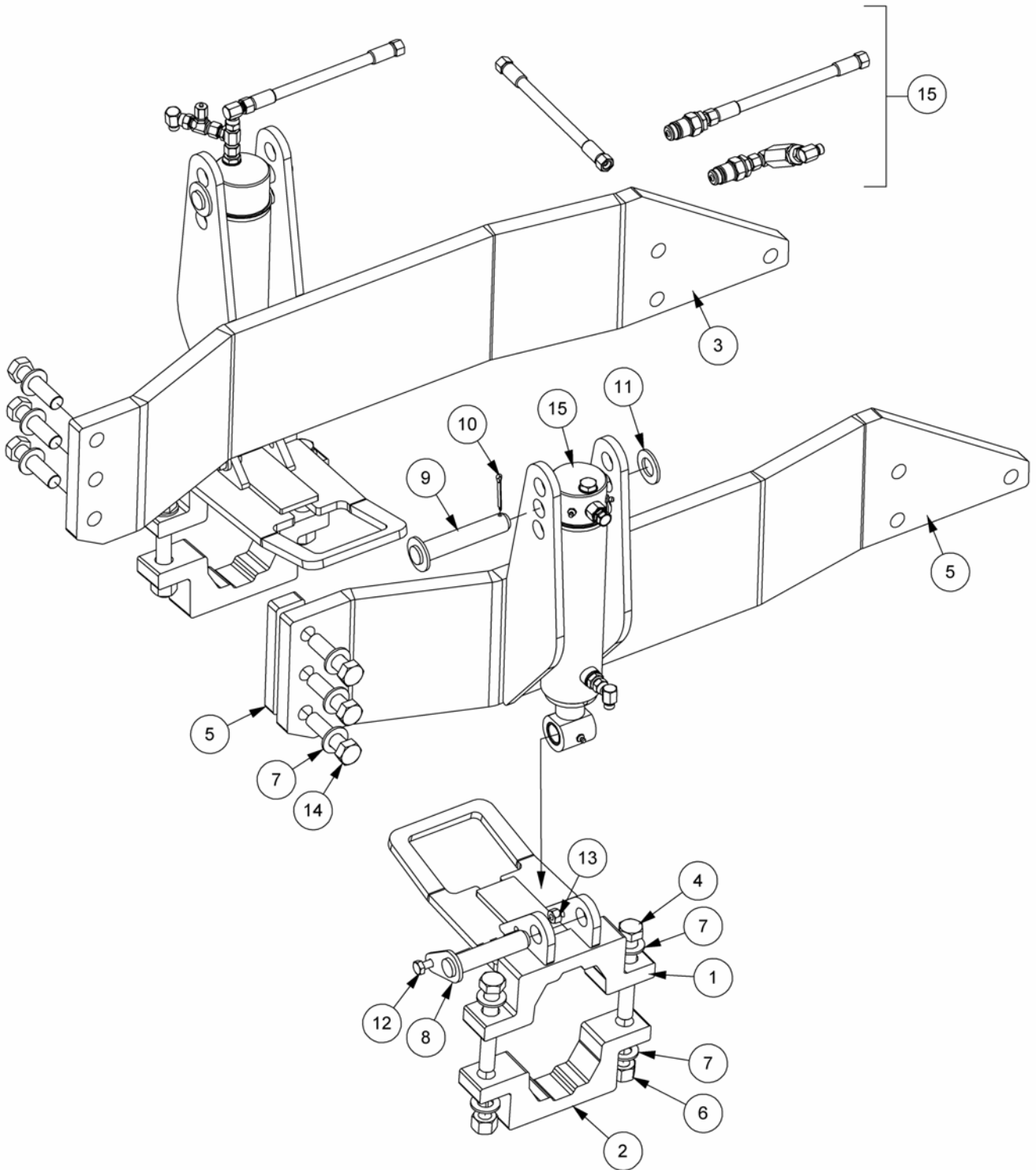



AXLE LOCKING KIT – MF6475

REF.	QTY.	PART No.	DESCRIPTION
		7780736	AXLE LOCKING KIT - MF6475
1	2	22018.03	AXLE BRACKET - AXLE LOCK
2	2	22018.34	STRADDLE CLAMP
3	1	22020.03	AXLE LOCK BRACKET - L/H
4	4	9213288	BOLT
5	1	22020.04	AXLE LOCK BRACKET - R/H
6	4	9143008	SELF-LOCKING NUT
7	14	9100108	FLAT WASHER
8	2	41267.04	PIN
9	2	42038.02	PIN
10	2	9501406	SPLIT PIN
11	2	0100109	FLAT WASHER
12	2	9313065	SETSCREW
13	2	9143005	SELF-LOCKING NUT
14	6	9200053	BOLT
15	1	7780741	HYDRAULIC KIT (AXLE LOCKING)

Model: PA8000M

AXLE HYDRAULIC KIT – MF6475



Module:
7780741

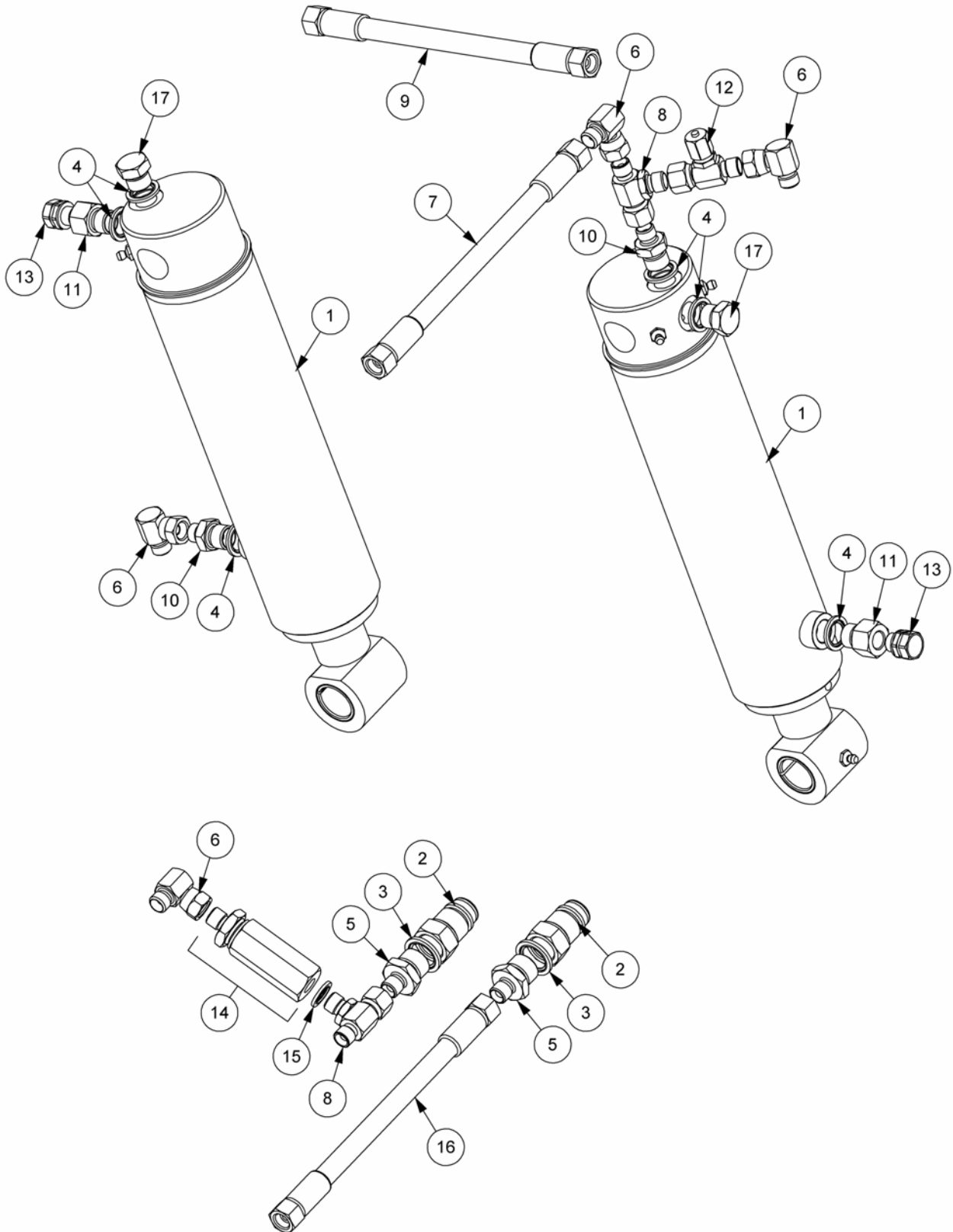



AXLE HYDRAULIC KIT – MF6475

REF.	QTY.	PART No.	DESCRIPTION
		7780741	AXLE LOCKING HYDRAULIC KIT - MF6475
1	2	41014.02	RAM ASSEMBLY
2	2	8590074	QUICK RELEASE COUPLING
3	2	8650104	BONDED SEAL
4	6	8650103	BONDED SEAL
5	2	8581172	ADAPTOR
6	4	8581190	ADAPTOR ELBOW - 90°
7	1	10.001.52	HOSE - 1/4" BSP FS/FS x 4200mm
8	2	8581254	ADAPTOR TEE
9	1	10.001.28	HOSE - 1/4" BSP FS/FS x 1800mm
10	2	8581115	ADAPTOR
11	2	8103005	ADAPTOR
12	1	T7814	TEST POINT
13	2	07.727.42	BREATHER
14	1	8130177	RELIEF VALVE ASSEMBLY
15	1	8650102	BONDED SEAL
16	1	10.001.09	HOSE - 1/4" BSP FS/FS x 450mm
17	2	8003001	ADAPTOR PLUG

AXLE KIT RAM ASSEMBLY

Module:
41014.02

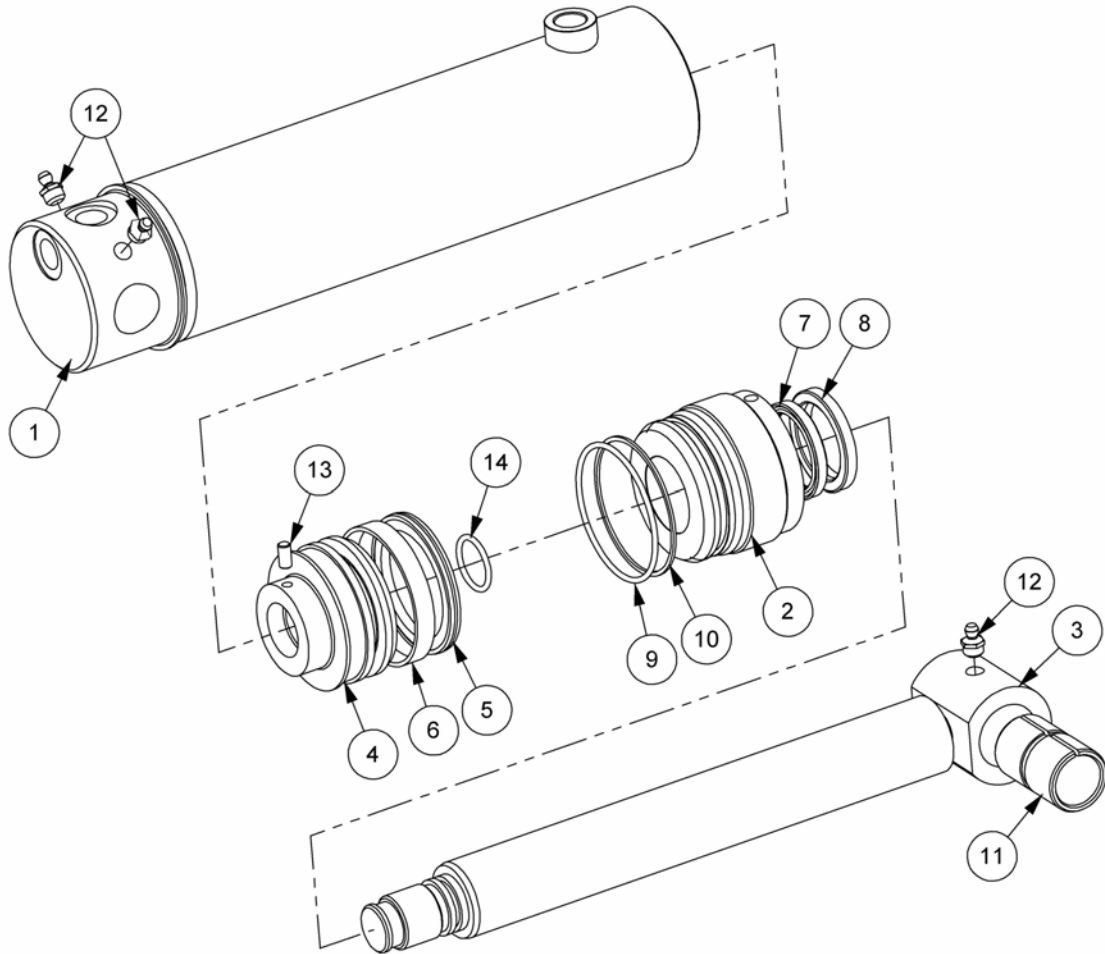

REF.	QTY.	PART No.	DESCRIPTION
		41014.02	RAM ASSEMBLY (LOCKING AXLE KIT)
1	1	41034.01	RAM BARREL
2	1	7120384	GLAND HOUSING
3	1	41035.01	PISTON ROD
4	1	7120383	PISTON
5	1	8629189	PISTON SEAL
6	1	8629190	GUIDE RING
7	1	8629164	GLAND SEAL
8	1	8629147	SCRAPER RING
9	1	8600429	O RING
10	1	8600429	ANTI EXTRUSION RING
11	1	7105050	ROD END BUSH
12	3	0901121	GREASE NIPPLE
13	1	9363023	GRUB SCREW
14	1	8600403	O RING
		8699228	SEAL KIT

Model: PA8000M

WHEEL WEIGHTS KIT – MF6475



Module:
7780801

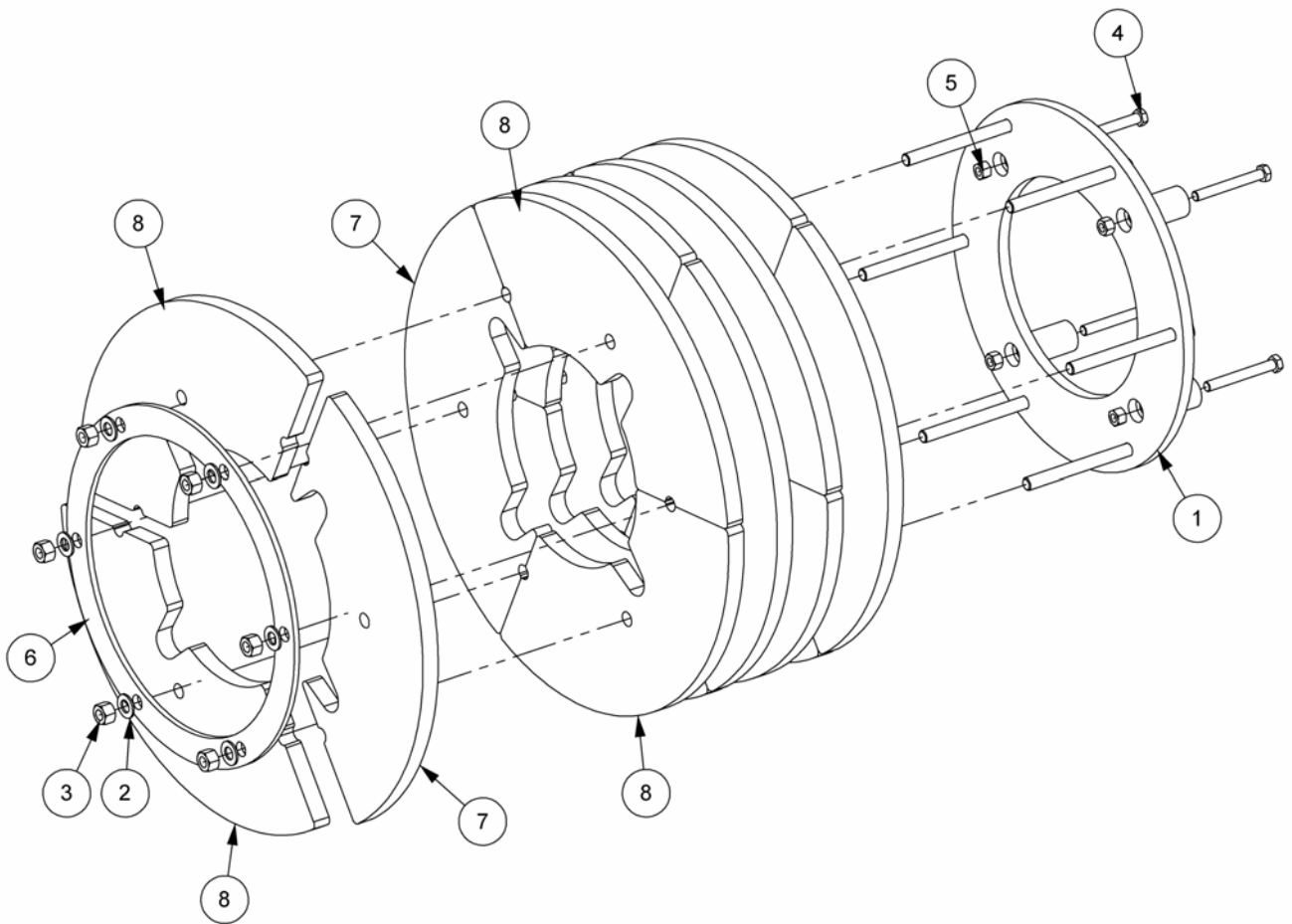

REF.	QTY.	PART No.	DESCRIPTION
		7780801	WHEEL WEIGHTS KIT - MF6475
1	1	21938.02	WHEEL WEIGHT CARRIER
2	6	9100108	FLAT WASHER
3	6	9143008	SELF-LOCKING NUT
4	4	9213267	BOLT
5	4	9143007	SELF-LOCKING NUT
6	1	22017.01	CLAMP RING
7	5	21939.02	WHEEL WEIGHT - MF TYPE 1
8	10	21939.03	WHEEL WEIGHT - MF TYPE 2

Model: PA8000M



MOUNTING FRAME

Module:
7780513

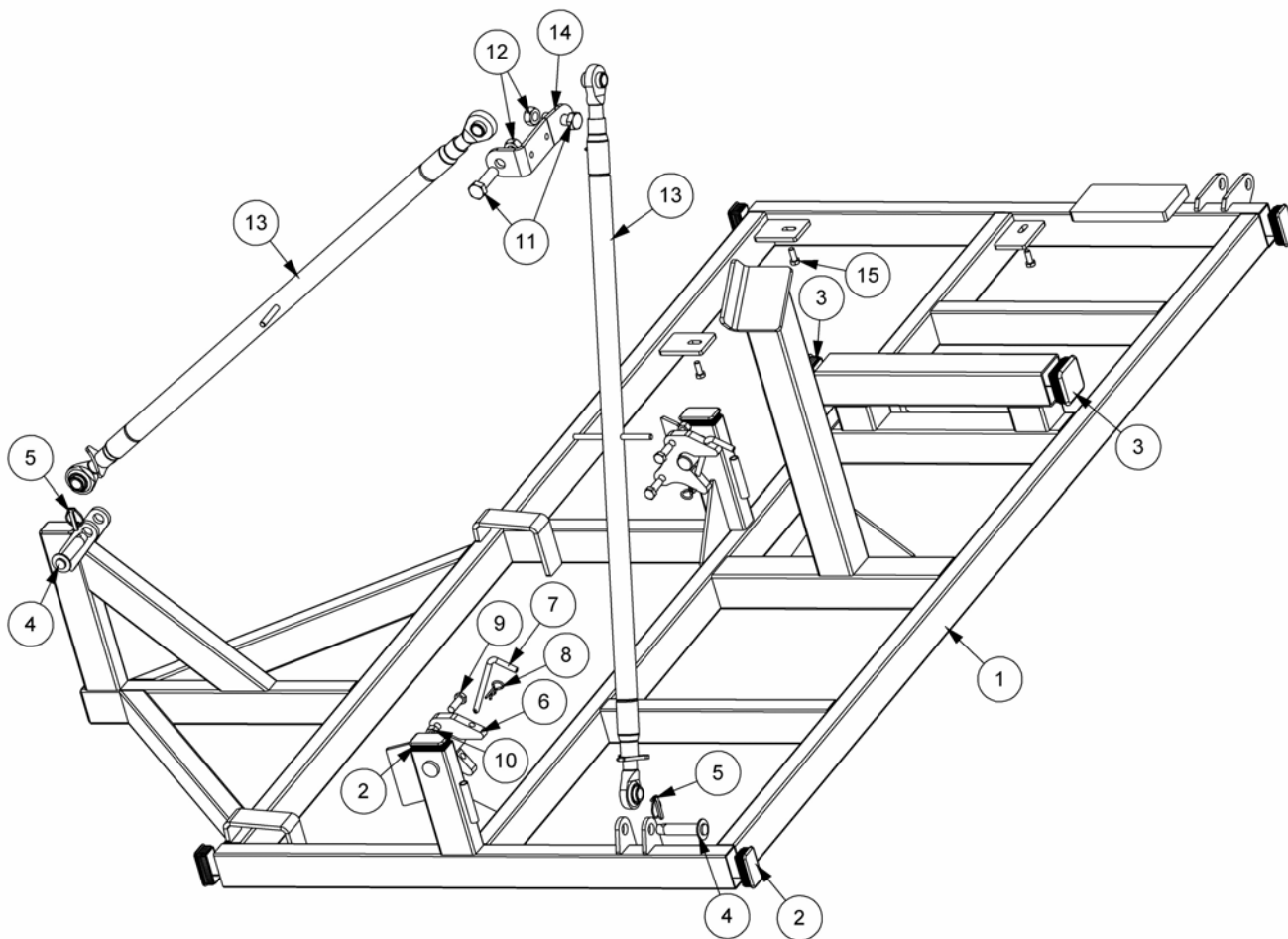

REF.	QTY.	PART No.	DESCRIPTION
		7780513	MOUNTING FRAME - PA8000M
1	1	21703.02	MOUNTING FRAME
2	8	45210.04	RECTANGULAR INSERT
3	2	45210.02	PLASTIC PLUG
4	2	7560144	W/ASSY-TOP LINK PIN
5	2	0431217	LINCH PIN
6	2	21704.01	HITCH JAW PLATE
7	2	21707.01	LOCKING PIN
8	2	0431105	SPRING COTTER
9	4	9313097	SETSCREW
10	4	9143007	SELF-LOCKING NUT
11	2	05.285.02	BOLT
12	2	9113009	NUT
13	2	21706.03	SCREW STRUT ASSEMBLY
14	1	21703.60	STRUT BRACKET
15	4	9213067	BOLT

Model: PA8000M

TRANSPORT CRADLE – MF6475



Module:
7780723

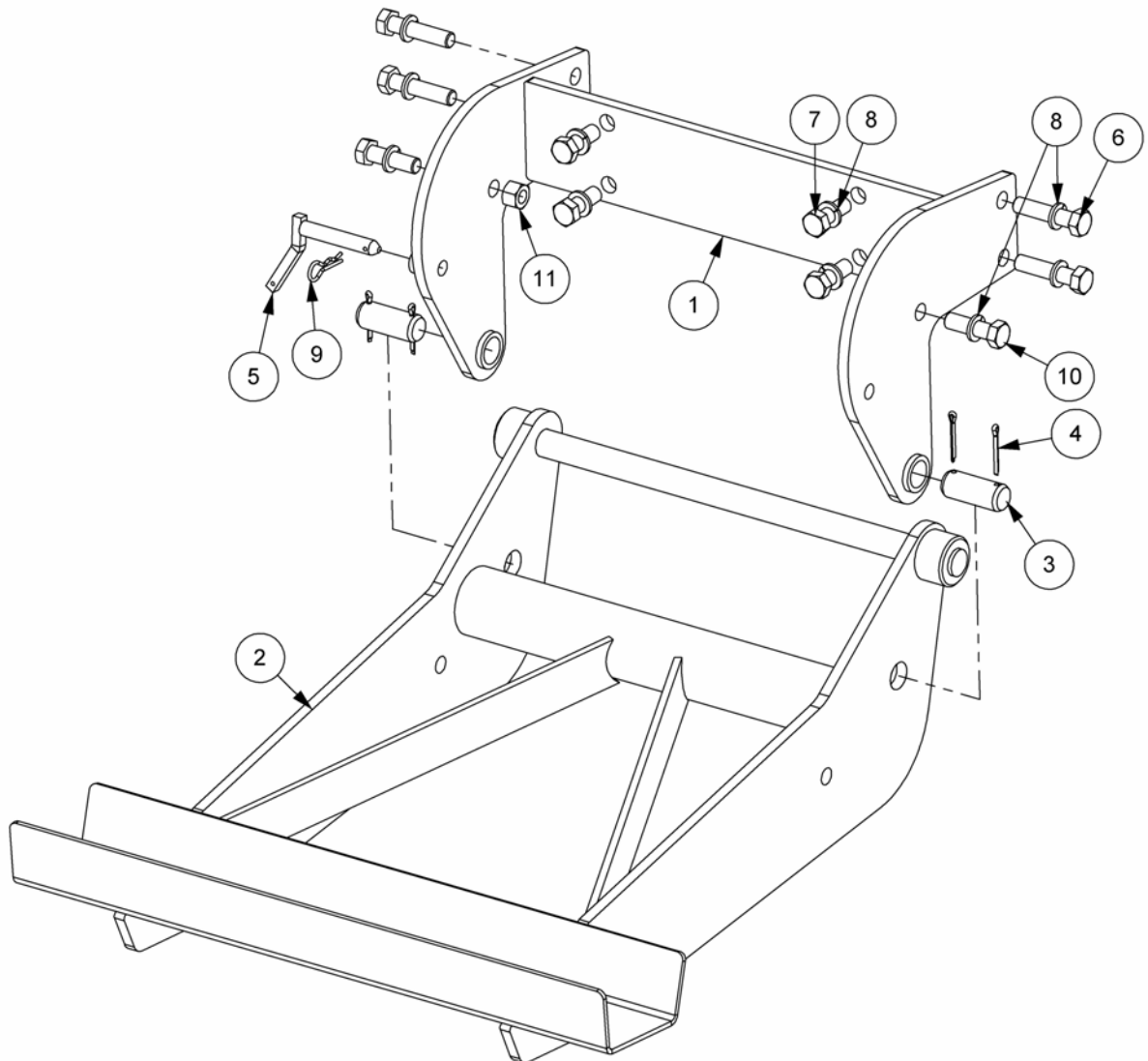

REF.	QTY.	PART No.	DESCRIPTION
		7780723	TRANSPORT CRADLE - MF6475
1	1	21921.02	TRANSPORT BRACKET - MF6475
2	1	21922.01	TRANSPORT CRADLE
3	2	21923.01	CRADLE PIVOT PIN
4	4	9501507	SPLIT PIN
5	1	7191036	RAM PIN
6	4	9213188	BOLT
7	4	9313118	SETSCREW
8	10	9100208	SPRING WASHER
9	1	0431105	SPRING COTTER
10	2	9213148	BOLT
11	2	9143008	SELF-LOCKING NUT

Model: PA8000M



CAB GUARD KIT

Module:
7313324

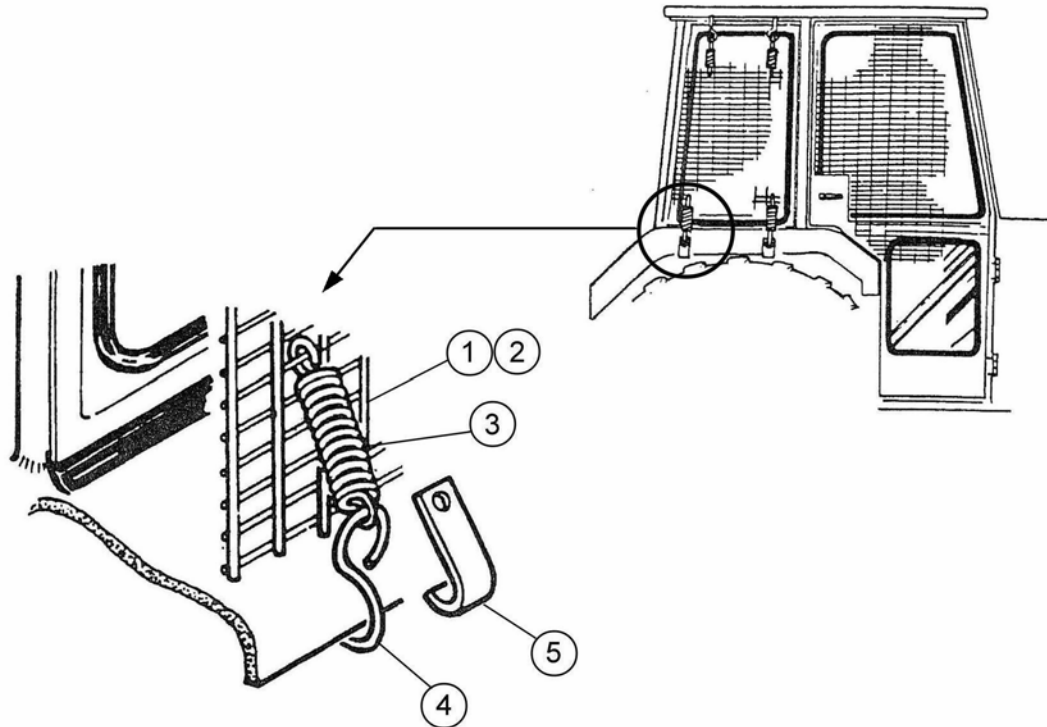

REF.	QTY.	PART No.	DESCRIPTION
		7313324	CAB GUARD & MOUNTING KIT
1	1	7313049	GUARD PANEL - LARGE
2	1	7313050	GUARD PANEL - SMALL
3	12	6001064	SPRING
4	6	6001065	HOOK
5	6	7313051	HOOK



McConnel Limited, Temeside Works, Ludlow, Shropshire SY8 1JL. England.
Telephone: 01584 873131. Facsimile: 01584 876463. www.mcconnel.com