

Publication 429  
February 2003  
Part No. 41570.29  
Revision: 20.10.08



# PA 6500

# PA 6500M

# PA 8000TT

## Parts Manual

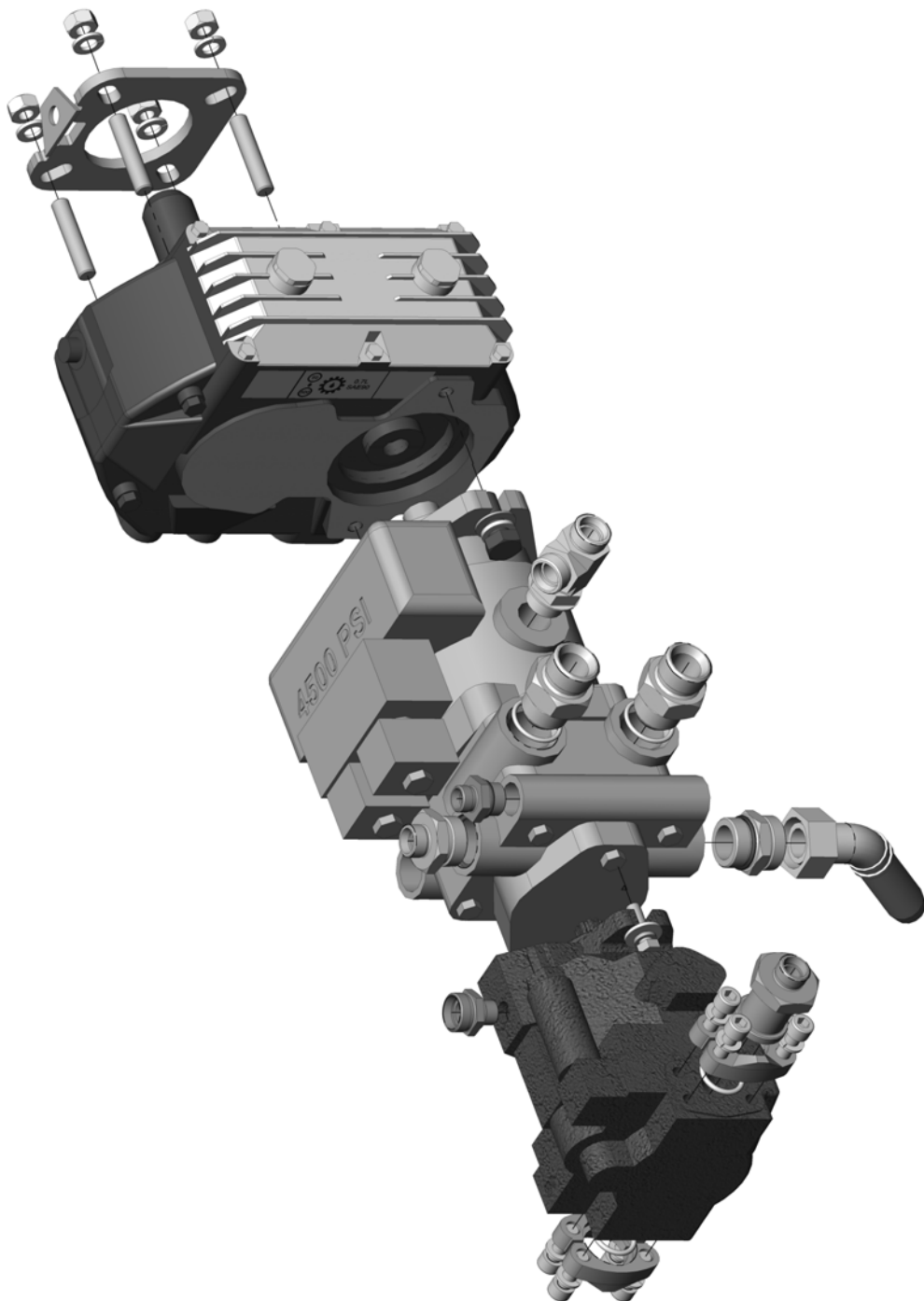



*For best performance ...*

## **USE ONLY GENUINE McCONEL SERVICE PARTS**

*To be assured of the latest design improvements purchase your  
'Genuine Replacements' from the 'Original Equipment Manufacturer'*

## **McCONEL LIMITED**

*Through your local Dealer or Stockist*

**Always quote:**

- ***Machine Type***
- ***Serial Number***
- ***Part Number***

*Design improvements may alter some of the parts listed in this manual –  
the latest part will always be supplied when it is interchangeable with an earlier one.*

**FOR NOTES**

# LIST OF CONTENTS

## Mainframe Components

Page No.

Mainframe	1
Pillar	3
Rocker	5
Hydraulic Tank	7

## Arm Components

Main Arm - <i>All models</i>	9
Dipper Arm - <i>Standard Arm models</i>	11
Dipper Arm - <i>Midcut Arm models</i>	13
Dipper Arm - <i>Tele Arm models</i>	15
Tele Socket Outer - <i>Tele models</i>	17
Tele Socket Inner - <i>Tele models</i>	19
Head Angling Mechanism - <i>All models</i>	21

## Hydraulic Components

Pump & Gearbox	23
Gearbox Assembly	25
Control Valve - <i>Standard Arm models</i>	27
Control Valve - <i>Tele &amp; Midcut models</i>	29
Solenoids	31
Slew Valve	33
Pump By-Pass	35
Charge Filter	37
Midcut Relief - <i>Midcut models</i>	39
Oil Cooler	41
Cooler Bypass Kit	43
Hose Installation - <i>Control Valve</i>	45
Hose Installation - <i>Tele Arm models</i>	47

## Hydraulic Rams

Angling Ram	51
Lift Ram	52
Reach Ram	53
Slew Ram	54
Tele Ram	55

## Control Components

Proportional Controls (v.3) - <i>All models</i>	57
Auxiliary Control Box - <i>Wiring diagram</i>	59
Auxiliary Control Box/Control Valve Mounting	60
EDS Sensor Kit	61
Power Monitor Kit	61
Controls Mounting	63

## Guarding & Safety Components

Cab Guard	64
Rear Covers	65
Rear Lighting	67
Machine Decals	69
Debris Blower Mounting Kit	71

# MAINFRAME ASSEMBLY

## MODULES:

7666500 – L/H Build

7666501 – R/H Build

*Illustrated in Left-Hand build*

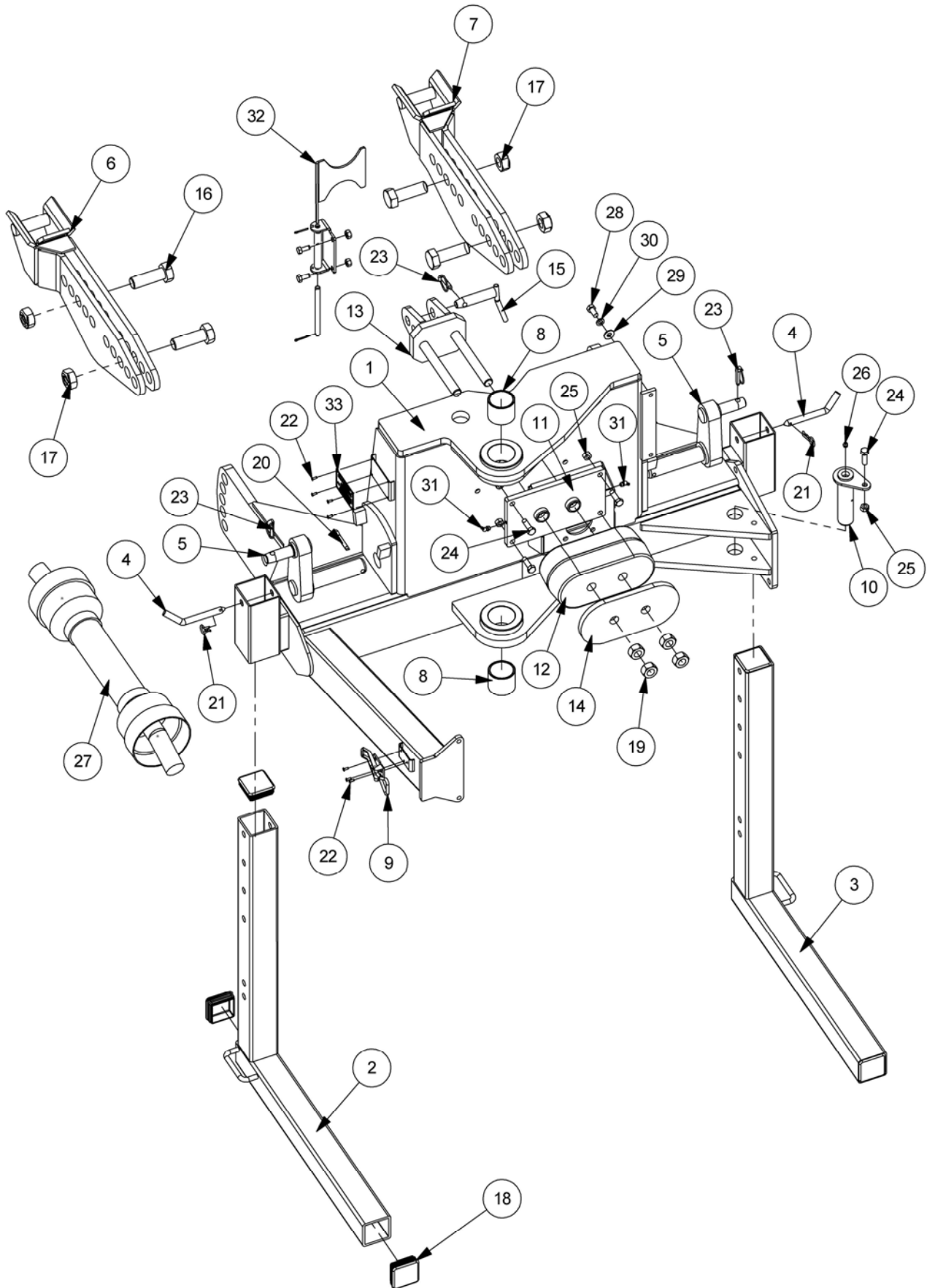



# MAINFRAME ASSEMBLY

REF.	QTY.	PART No.	DESCRIPTION
		<b>7666500</b>	<b>MAIN FRAME ASSEMBLY - L/H Build</b>
		<b>7666501</b>	<b>MAIN FRAME ASSEMBLY - R/H Build</b>
1	1	21059.03	MAIN FRAME - L/H Build
	1	21059.04	MAIN FRAME - R/H Build ( <i>not illustrated</i> )
2	1	21068.01	STAND LEG - L/H
3	1	21068.02	STAND LEG - R/H
4	2	43327.01	LEG PIN
5	2	43319.01	LIFT LINK
6	1	21105.02	MOUNTING ARM - TYPE 2
	1	21105.04	* EXTENDED MOUNTING ARM - TYPE 2
7	1	21105.01	MOUNTING ARM - TYPE 1
	1	21105.03	* EXTENDED MOUNTING ARM - TYPE 1
8	2	08.297.06	BUSH
9	1	43449.01	OVERCENTRE FASTENER
10	1	21098.05	PIN - SLEW BASE
11	1	45807.01	REACTION PLATE
12	1	7560141	RUBBER SPRING
13	1	7560398	TOP HITCH BRACKET
14	1	7560130	REACTION PLATE
15	1	43342.01	TOP LINK PIN
16	4	9200035	BOLT
17	4	9100023	BINX NUT
18	6	41580.01	PLASTIC PLUG
19	4	9113009	NUT
20	2	9501509	SPLIT PIN
21	2	0431105	SPRING COTTER
22	7	1069088	POP RIVET
23	3	0431217	LINCH PIN
24	5	9213086	BOLT
25	5	9143006	SELF-LOCKING NUT
26	1	0901121	GREASE NIPPLE - STRAIGHT
27	1	7650250	DRIVE SHAFT
28	2	9313056	SETSCREW
29	2	9100106	FLAT WASHER
30	2	9100206	SPRING WASHER
31	2	0901125	GREASE NIPPLE - 45°
32	1	21187.01	PTO SUPPORT BRACKET KIT - <i>comprising of:</i>
	1	21183.01	PTO SUPPORT BRACKET
	1	21186.01	PIN
	1	21184.01	BRACKET
	2	9313055	SETSCREW
	2	9143005	SELF-LOCKING NUT
	2	9501255	SPLIT PIN
33	1	1335246	SERIAL No. PLATE

\* *Optional components*

# PILLAR ASSEMBLY

## MODULES:

7666504 – L/H Build

7666505 – R/H Build

*Illustrated in Left-Hand build*

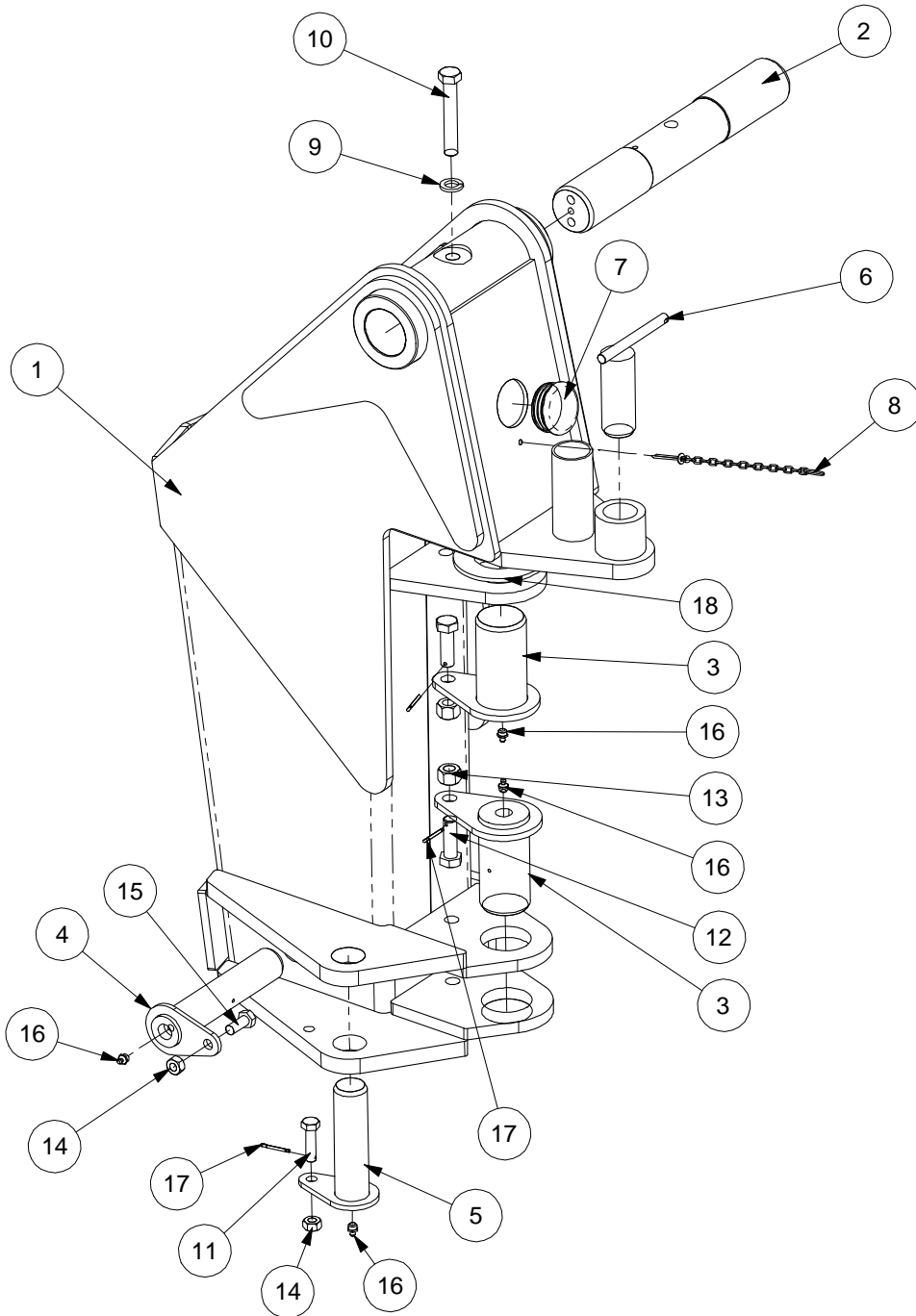

**PILLAR ASSEMBLY**

REF.	QTY.	PART No.	DESCRIPTION
		<b>7666504</b>	<b>PILLAR ASSEMBLY - L/H BUILD</b>
		<b>7666505</b>	<b>PILLAR ASSEMBLY - R/H BUILD</b>
1	1	21061.01	PILLAR - L/H
	1	21061.02	PILLAR - R/H ( <i>not illustrated</i> )
2	1	21078.01	MAIN PIVOT PIN
3	2	21099.01	W/ASSY-SLEW PIVOT PIN
4	1	21098.04	W/ASSY-PIN-LIFT BASE
5	1	21098.02	W/ASSY-PIN-ROCKER
6	1	43323.01	W/ASSY-SLEW LOCK PIN
7	1	43358.01	PLASTIC PLUG-65 DIA
8	1	03.255.05	CHAIN/RING ASSY
9	1	9100207	SPRING WASHER M16
10	1	9213207	BOLT M16x100
11	1	42269.06	SPECIAL BOLT M12x45
12	2	42269.03	SPECIAL BOLT M16x50
13	2	9143007	SELF-LOCKING NUT M16
14	2	9143006	SELF-LOCKING NUT M12
15	1	9313066	SETSCREW M12x30
16	4	0901121	GREASE NIPPLE 1/8in BSP Str.
17	3	9501255	M4 x 25 SPLIT PIN
18	1	21135.01	THRUST WASHER 110x61x5





# ROCKER ASSEMBLY

MODULE:  
7666506

*Illustrated in Left-Hand build*

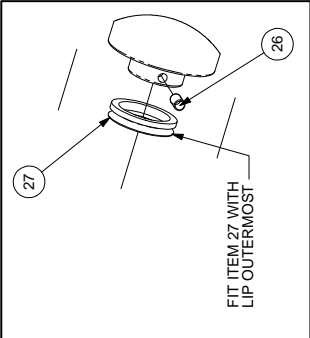
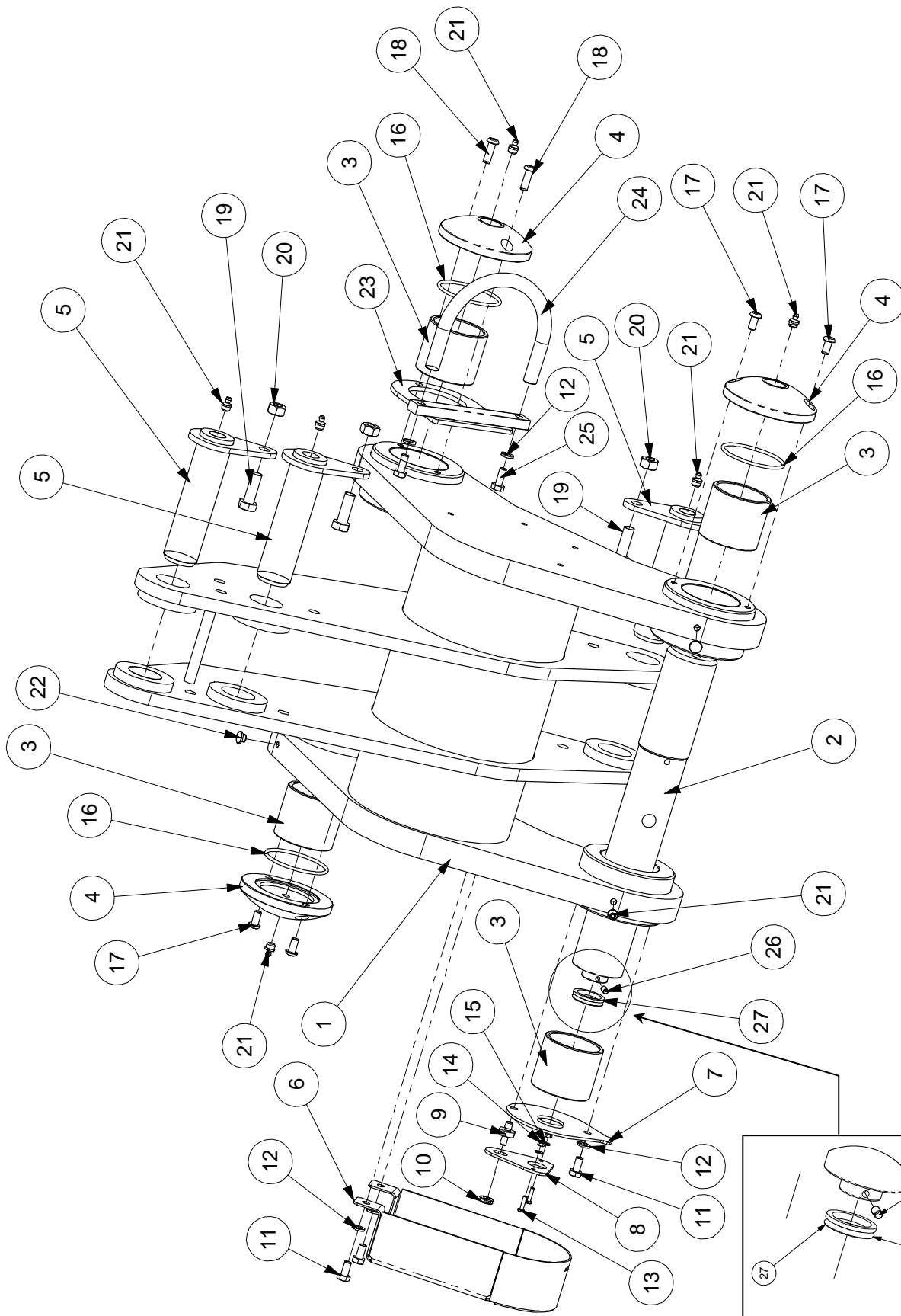

**ROCKER ASSEMBLY**

REF.	QTY.	PART No.	DESCRIPTION
		<b>7666506</b>	<b>ROCKER ASSEMBLY</b>
1	1	21062.02	ROCKER
2	1	21078.02	MAIN PIVOT PIN - EDS
3	4	08.297.06	BUSH
4	3	21077.01	PIN CAP
5	3	21098.02	PIN - ROCKER
6	1	21120.01	SENSOR COVER
7	1	21117.01	COVER PLATE
8	1	21118.01	REACTION PLATE
9	1	43014.02	LOCATING STUD
10	1	43356.01	GROMMET
11	3	9313034	SETSCREW
12	5	9100204	SPRING WASHER
13	2	9300162	POSI PANHEAD SCREW
14	2	05.948.33	NUT SELF LOCK
15	2	9100101	FLAT WASHER
16	3	8600310	O RING
17	4	9300159	BUTT HEAD - SOCKET HEAD
18	2	9300158	BUTTON HEAD CAP SCREW
19	3	9313076	SETSCREW
20	3	9143006	SELF-LOCKING NUT
21	7	0901121	GREASE NIPPLE
22	3	42964.02	PLASTIC PLUG
23	1	21129.01	HOSE BRACKET
24	1	43048.05	HOOK
25	2	9313044	SETSCREW
26	1	9363023	GRUB SCREW
27	1	8629232	V RING

*NOTE: Rocker components for Left-Hand and Right-Hand machines are common to both assemblies, the illustration opposite shows a Left-Hand build, the assembly is a mirror of this for a Right-Hand machine.*

# HYDRAULIC TANK ASSEMBLY

**MODULES:**

7666502 – L/H Build

7666503 – R/H Build

*Illustrated in Left-Hand build*

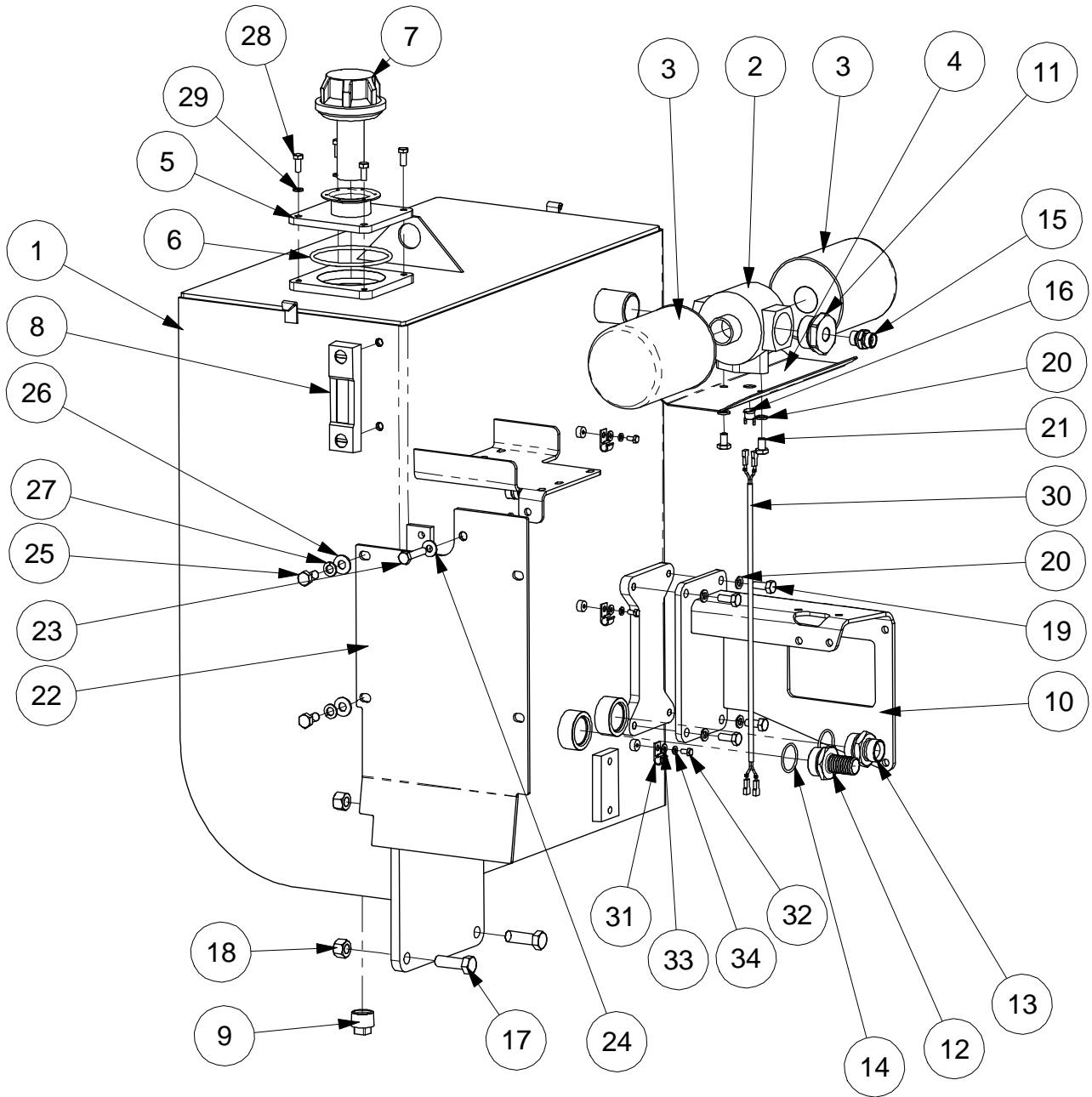



## HYDRAULIC TANK ASSEMBLY

REF.	QTY.	PART No.	DESCRIPTION
		<b>7666502</b>	<b>HYDRAULIC TANK ASSEMBLY - L/H Build</b>
		<b>7666503</b>	<b>HYDRAULIC TANK ASSEMBLY - R/H Build</b>
1	1	21066.01	TANK - L/H
	1	21066.02	TANK - R/H ( <i>not illustrated</i> )
2	1	8401060	RETURN FILTER HEAD
3	2	8401070	FILTER
4	1	43471.01	DRIP TRAY
5	1	43175.01	COVER PLATE
6	1	8600151	O RING 348
7	1	8401074	FILLER BREATHER
8	1	8401048	LEVEL GAUGE
9	1	8581203	TAPER PLUG
10	1	21104.01	VALVE BRACKET - L/H
	1	21104.02	VALVE BRACKET - R/H ( <i>not illustrated</i> )
11	1	8581401	ADAPTOR
12	1	8581383	SUCTION ADAPTOR
13	1	8002104	MALE ADAPTOR
14	2	8700784	O RING 784
15	1	G3812674	ADAPTOR
16	1	8402236	THERMAL CUTOUT
17	3	9213107	BOLT
18	3	9143007	SELF-LOCKING NUT
19	4	9313055	SETSCREW
20	6	9100205	SPRING WASHER
21	2	9313035	SETSCREW
22	1	21074.01	SHIELD PLATE - L/H
	1	21074.02	SHIELD PLATE - R/H ( <i>not illustrated</i> )
23	1	9213105	BOLT
24	1	9100105	FLAT WASHER
25	2	9313056	SETSCREW
26	2	9100106	FLAT WASHER
27	2	9100206	SPRING WASHER
28	4	9313044	SETSCREW
29	4	9100204	SPRING WASHER
30	1	43177.30	LOOM -THERMAL CUTOUT FILTERS
31	4	21151.01	D CLIP
32	4	9313023	SETSCREW
33	4	9100103	FLAT WASHER
34	4	9100203	SPRING WASHER

# MAIN ARM ASSEMBLY

## MODULES:

7666508 – L/H build

7666509 – R/H build

7666527 – L/H Midcut build

7666528 – R/H Midcut build

*Illustrated in Left-Hand build*

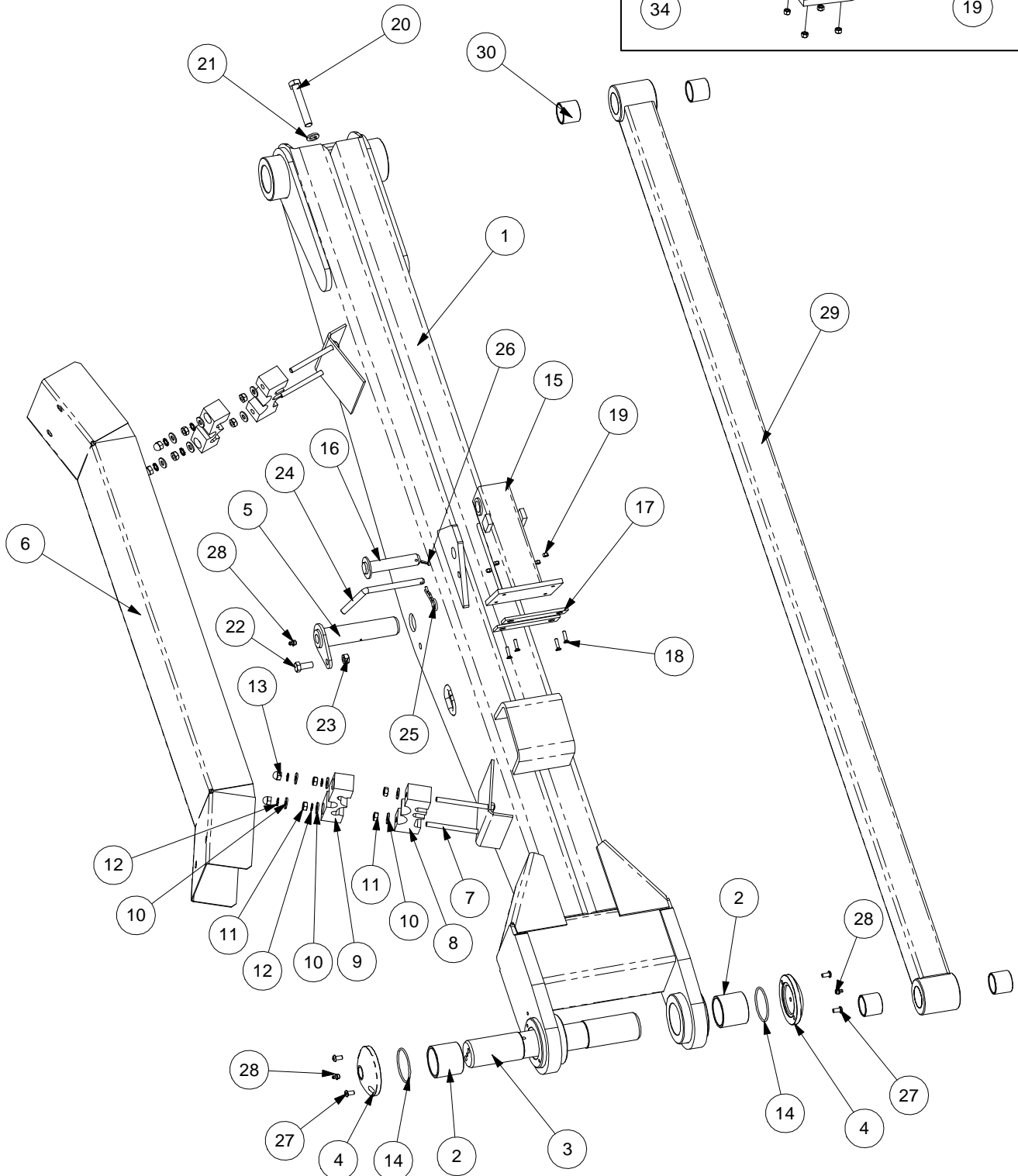
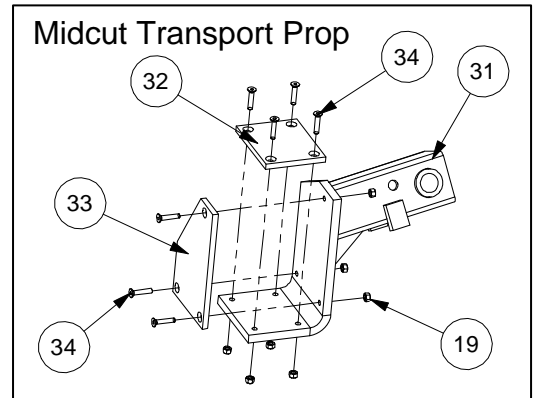



# MAIN ARM ASSEMBLY

REF.	QTY.		PART No.	DESCRIPTION
			<b>7666508</b>	<b>MAIN ARM ASSEMBLY - L/H BUILD</b>
			<b>7666509</b>	<b>MAIN ARM ASSEMBLY - R/H BUILD</b>
			<b>7666527</b>	<b>MAIN ARM ASSEMBLY - L/H MIDCUT BUILD</b>
	<i>Std.</i>	<i>M/cut</i>	<b>7666528</b>	<b>MAIN ARM ASSEMBLY - R/H MIDCUT BUILD</b>
1	1	1	21026.03	MAIN ARM - L/H
	1	1	21026.04	MAIN ARM - R/H ( <i>not illustrated</i> )
2	2	2	08.297.06	BUSH
3	1	1	21078.01	MAIN PIVOT PIN
4	2	2	21077.01	PIN CAP
5	1	1	21098.03	PIN - REACH BASE
6	1	1	21116.01	HOSE COVER - MAIN ARM
7	4	4	42198.01	STUD
8	2	2	42024.02	MULTI HOSE CLAMP
9	2	2	42024.03	MULTI CLAMP - UPPER
10	12	12	9100105	FLAT WASHER
11	8	8	9113005	NUT
12	8	8	9100405	SHAKEPROOF WASHER
13	4	4	9100025	DOME NUT
14	2	2	8600310	O RING
15	1	<i>n/a</i>	21131.01	TRANSPORT PROP
16	1	1	43023.01	PIN - TRANSPORT PROP
17	2	<i>n/a</i>	43091.03	PAD - TRANSPORT PROP
18	4	<i>n/a</i>	9353053	CAPSCREW
19	4	7	9143003	SELF-LOCKING NUT
20	1	1	9213207	BOLT
21	1	1	9100207	SPRING WASHER
22	1	1	9313066	SETSCREW
23	1	1	9143006	SELF-LOCKING NUT
24	1	1	43074.01	LOCK PIN - TRANSPORT PROP
25	1	1	0431105	SPRING COTTER
26	1	1	9501406	SPLIT PIN
27	4	4	9300159	SCREW - BUTTON HEAD/SOCKED HEAD
28	3	3	0901121	GREASE NIPPLE
29	1	1	21027.01	TENSION LINK
30	4	4	08.297.02	BUSH
31	<i>n/a</i>	1	45606.01	TRANSPORT PROP - L/H MIDCUT BUILD
	<i>n/a</i>	1	45606.02	TRANSPORT PROP - R/H MIDCUT BUILD
32	<i>n/a</i>	1	43091.02	SIDE PAD - MIDCUT CRADLE
33	<i>n/a</i>	1	43091.01	MAIN PAD - MIDCUT CRADLE
34	<i>n/a</i>	7	9353063	CAPSCREW

# DIPPER ARM ASSEMBLY

**MODULES:**

7666519 – L/H build

7666520 – R/H build

*Illustrated in Left-Hand build*

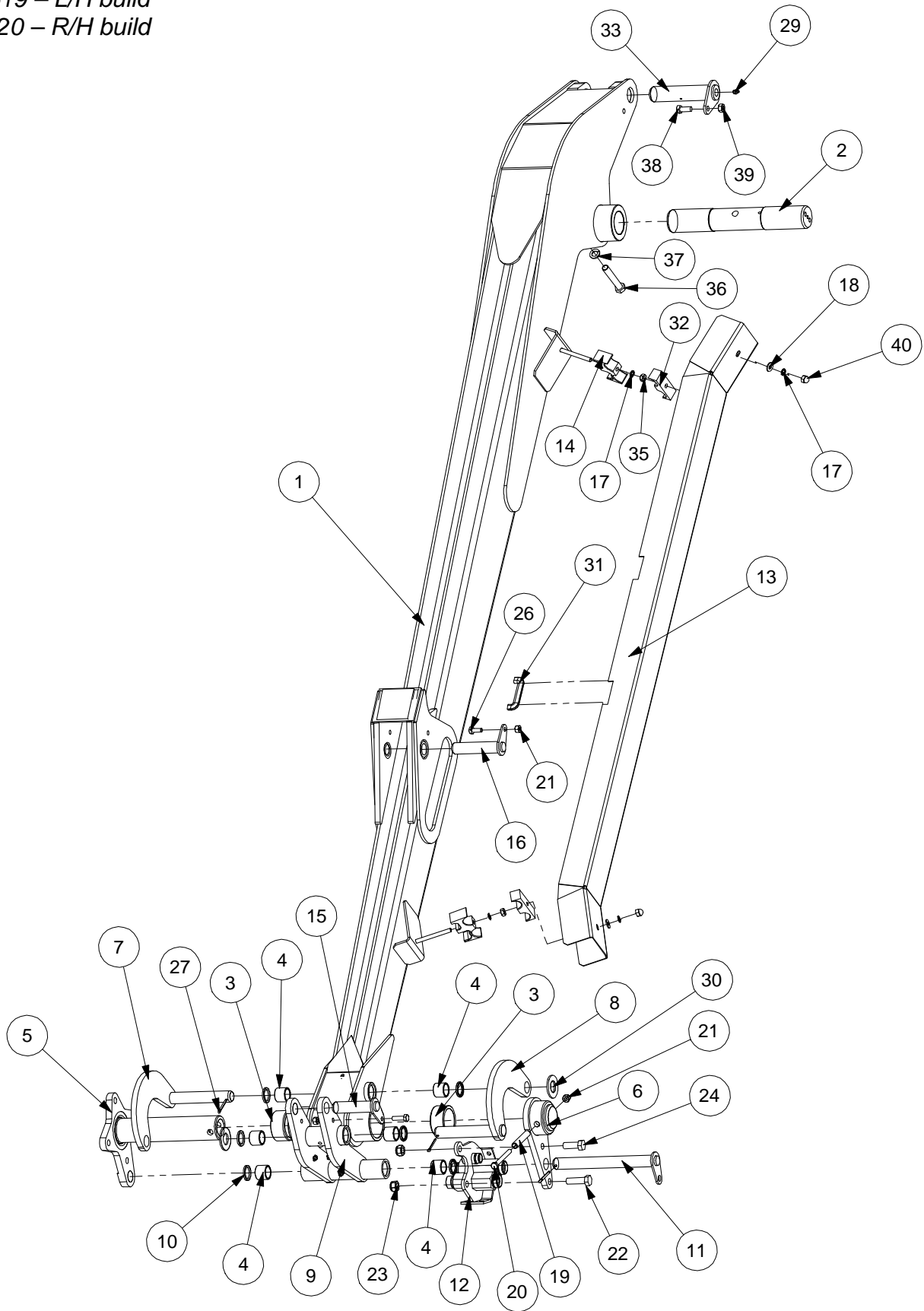

*Refer to page 21 for detailed illustration of Head Angling Mechanism.*



## DIPPER ARM ASSEMBLY

REF.	QTY.	PART No.	DESCRIPTION
		<b>7666519</b>	<b>DIPPER ARM ASSEMBLY - L/H BUILD</b>
		<b>7666520</b>	<b>DIPPER ARM ASSEMBLY - R/H BUILD</b>
1	1	21169.01	STANDARD DIPPER ARM - L/H
	1	21169.02	STANDARD DIPPER ARM - R/H ( <i>not illustrated</i> )
2	1	21078.01	MAIN PIVOT PIN
3	2	7136035	PLASTIC BUSH
4	6	08.297.04	BUSH
5	1	42649.01	PIVOT TUBE
6	1	42648.01	JAW PLATE
7	1	42646.03	RADIUS ARM - TYPE 1
8	1	42646.04	RADIUS ARM - TYPE 2
9	1	42647.02	SLAVE LINK
10	6	8629218	LIP SEAL
11	1	42684.01	PIN - SLAVE LINK
12	1	43055.02	HOSE BRACKET
13	1	41665.09	HOSE COVER
14	2	06.430.18	HOSE CLAMP - LOWER
15	1	42684.05	PIN
16	1	42684.08	PIN - ANGLE BASE
17	4	9100405	SHAKEPROOF WASHER - EXTERNAL
18	2	9100105	FLAT WASHER
19	1	0423556	SPRING DOWEL
20	1	9213205	BOLT
21	3	9143005	SELF-LOCKING NUT
22	1	9200023	BOLT
23	2	9100028	SELF-LOCKING NUT
24	1	9200028	BOLT
25	1	9313075	SETSCREW
26	1	9313055	SETSCREW
27	2	9501406	SPLIT PIN
28	1	9501507	SPLIT PIN
29	7	0901121	GREASE NIPPLE
30	2	05.281.18	FLAT WASHER
31	1	41741.01	EDGING STRIP
32	2	06.430.17	HOSE CLAMP - UPPER
33	1	21098.03	PIN - REACH BASE
34	2	42198.02	STUD
35	2	9113005	NUT
36	1	9213207	BOLT
37	1	9100207	SPRING WASHER
38	1	9313066	SETSCREW
39	1	9143006	SELF-LOCKING NUT
40	2	9100025	DOME NUT

Component parts for Left Hand and Right Hand Builds are identical with the exception of item: 1. Right Hand assembly is a mirror of the Left hand build illustrated opposite.



# MIDCUT DIPPER ARM ASSEMBLY

**MODULES:**

7666521 – Midcut L/H build

7666522 – Midcut R/H build

*Illustrated in Left-Hand build*

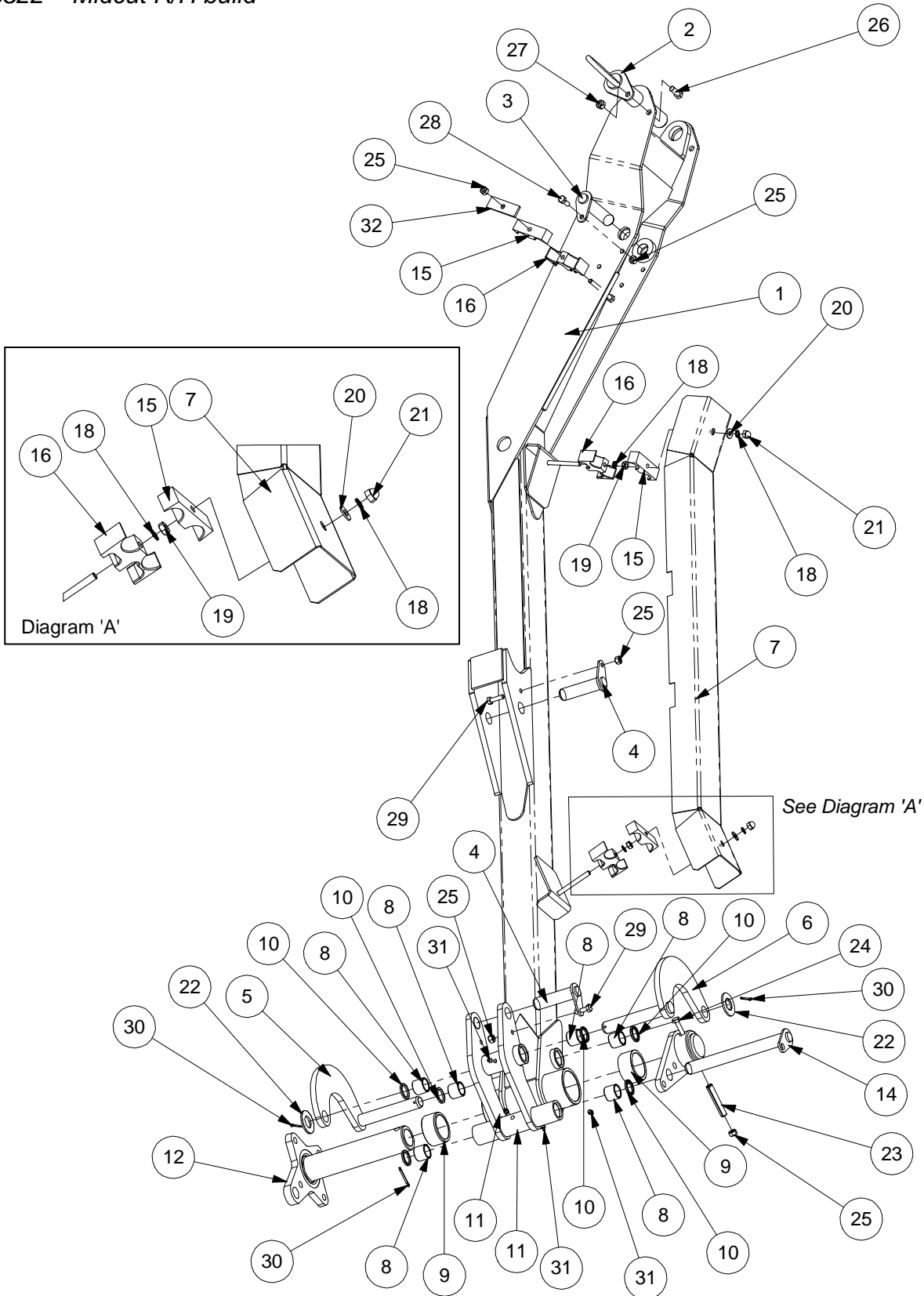

*Refer to page 21 for detailed illustration of Head Angling Mechanism.*



# MIDCUT DIPPER ARM ASSEMBLY

REF.	QTY.	PART No.	DESCRIPTION
		<b>7666521</b>	<b>MIDCUT DIPPER ASSEMBLY - L/H BUILD</b>
		<b>7666522</b>	<b>MIDCUT DIPPER ASSEMBLY - R/H BUILD</b>
1	1	21174.01	MIDCUT DIPPER OUTER - L/H
	1	21174.02	MIDCUT DIPPER OUTER - R/H ( <i>not illustrated</i> )
2	1	45609.01	PIN - MIDCUT FOLD
3	1	42684.03	PIN - FOLD RAM ROD END
4	2	42684.05	PIN
5	1	42646.03	RADIUS ARM - TYPE 1
6	1	42646.04	RADIUS ARM - TYPE 2
7	1	41665.27	HOSE COVER
8	6	08.297.04	BUSH
9	2	7136035	PLASTIC BUSH
10	6	8629218	LIP SEAL
11	1	42647.02	SLAVE LINK
12	1	42649.01	PIVOT TUBE
13	1	42648.01	JAW PLATE
14	1	42684.01	PIN - SLAVE LINK
15	3	06.430.17	HOSE CLAMP - UPPER
16	3	06.430.18	HOSE CLAMP - LOWER
17	2	42198.02	STUD
18	5	9100405	SHAKEPROOF WASHER - EXTERNAL
19	3	9113005	NUT
20	2	9100105	FLAT WASHER
21	2	9100025	DOME NUT
22	2	05.281.18	FLAT WASHER
23	1	0423556	SPRING DOWEL
24	2	9213205	BOLT
25	5	9143005	SELF-LOCKING NUT
26	1	9313066	SETSCREW
27	1	9143006	SELF-LOCKING NUT
28	1	9313055	SETSCREW
29	2	9313075	SETSCREW
30	3	9501406	SPLIT PIN
31	4	0901121	GREASE NIPPLE
32	1	06.418.05	CLAMP PLATE - PIPE CLAMP

*Component parts for Left Hand and Right Hand Builds are identical with the exception of item: 1. Assembly of Right Hand build is a mirror of the Left Hand build illustrated.*

# TELE DIPPER ARM ASSEMBLY

## MODULES:

7680504 – PA8000 L/H Models

7680505 – PA8000 R/H Models

*Illustrated in Left-Hand build*

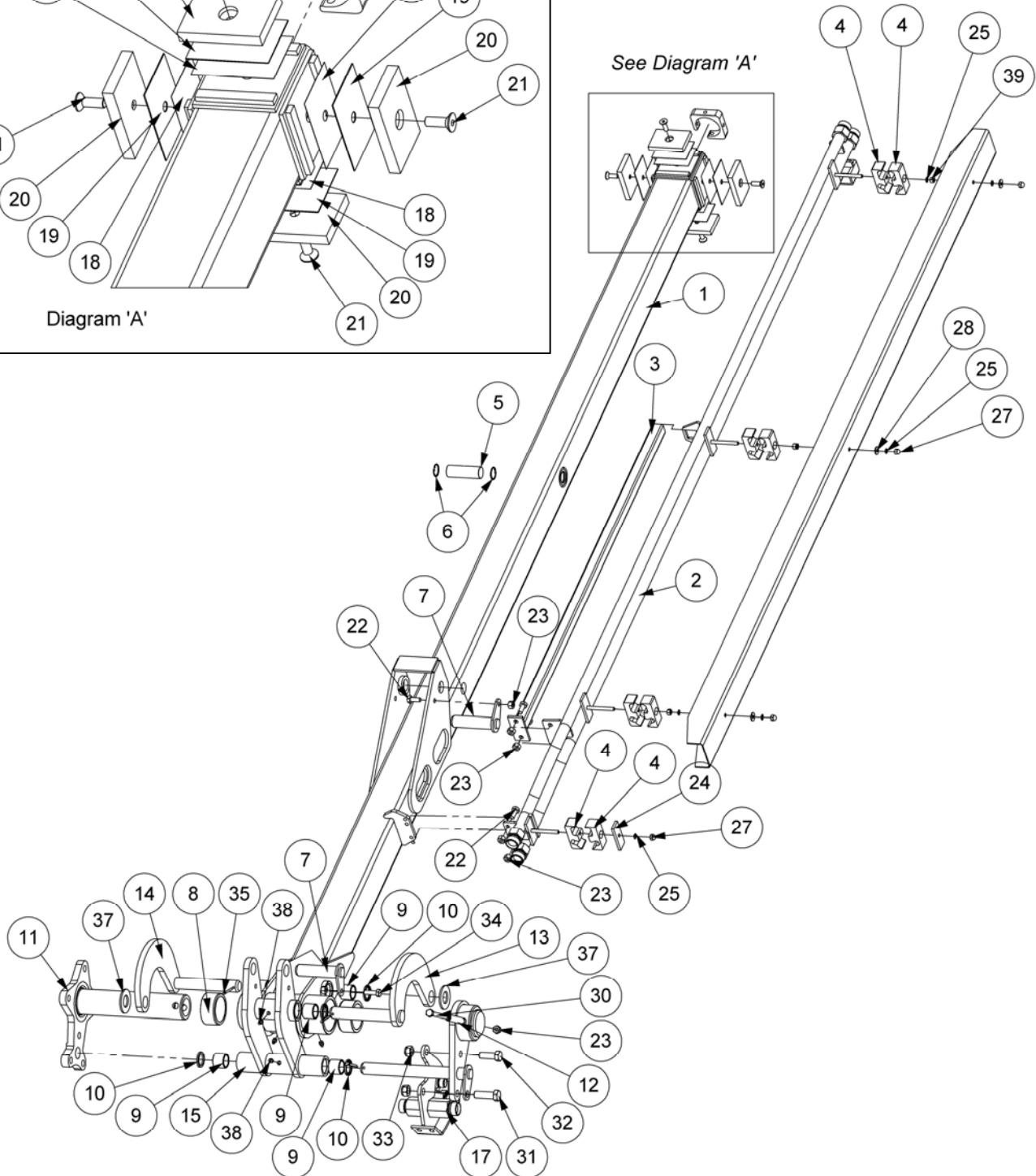
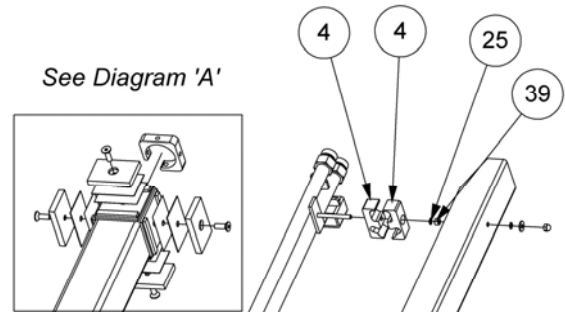
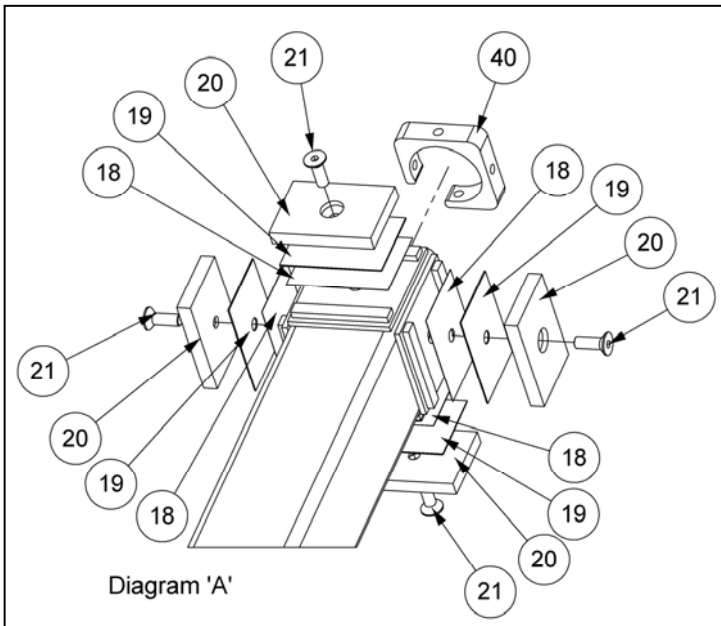

*Refer to page 21 for detailed illustration of Head Angling Mechanism.*

**TELE DIPPER ARM ASSEMBLY**

REF.	QTY.	PART No.	DESCRIPTION
		<b>7680504</b>	<b>TELE DIPPER ASSEMBLY - L/H BUILD</b>
		<b>7680505</b>	<b>TELE DIPPER ASSEMBLY - R/H BUILD</b>
1	1	21021.01	TELE DIPPER - INNER L/H
	1	21021.02	TELE DIPPER - INNER R/H ( <i>not illustrated</i> )
2	1	21053.03	RIGID PIPE - L/H
	1	21053.04	RIGID PIPE - R/H ( <i>not illustrated</i> )
3	1	21084.01	GUIDE RAIL
4	8	21076.01	HOSE CLAMP
5	1	21097.02	PIN - TELE BASE
6	2	0411230	CIRCLIP - INTERNAL
7	2	42684.05	PIN
8	2	7136035	PLASTIC BUSH
9	6	08.297.04	BUSH
10	6	8629218	LIP SEAL
11	1	42649.01	PIVOT TUBE
12	1	42648.01	JAW PLATE
13	1	42646.04	RADIUS ARM - TYPE 2
14	1	42646.03	RADIUS ARM - TYPE 1
15	1	42647.02	SLAVE LINK
16	1	42684.01	PIN - SLAVE LINK
17	1	43055.02	HOSE BRACKET
18	4	7136058	SHIM - 0.25mm
19	4	7136059	SHIM - 1.0mm
20	4	7136001	DIPPER WEAR STRIP
21	4	9353065	CAPSCREW
22	5	9313055	SETSCREW
23	7	9143005	SELF-LOCKING NUT
24	1	7198093	CLAMP PLATE
25	7	9100404	SHAKEPROOF WASHER
26	1	21055.01	HOSE COVER
27	4	9100031	DOMED NUT - PLATED
28	3	9100104	FLAT WASHER
29	1	0423556	SPRING DOWEL
30	1	9213205	BOLT
31	1	9200023	BOLT
32	1	9200028	BOLT
33	2	9100028	SELF LOCKING NUT
34	1	9313075	SETSCREW
35	2	9501406	SPLIT PIN
36	1	9501507	SPLIT PIN
37	2	05.281.18	FLAT WASHER
38	4	0901121	GREASE NIPPLE - STRAIGHT
39	3	9113004	NUT
40	1	21141.01	GUIDE BLOCK

*Component parts for Left Hand and Right Hand Builds are identical with the exception of items: 1 & 2*

# TELE SOCKET OUTER ASSEMBLY

## MODULES:

7680500 – PA8000 L/H Models

7680501 – PA8000 R/H Models

*Illustrated in Left-Hand build*

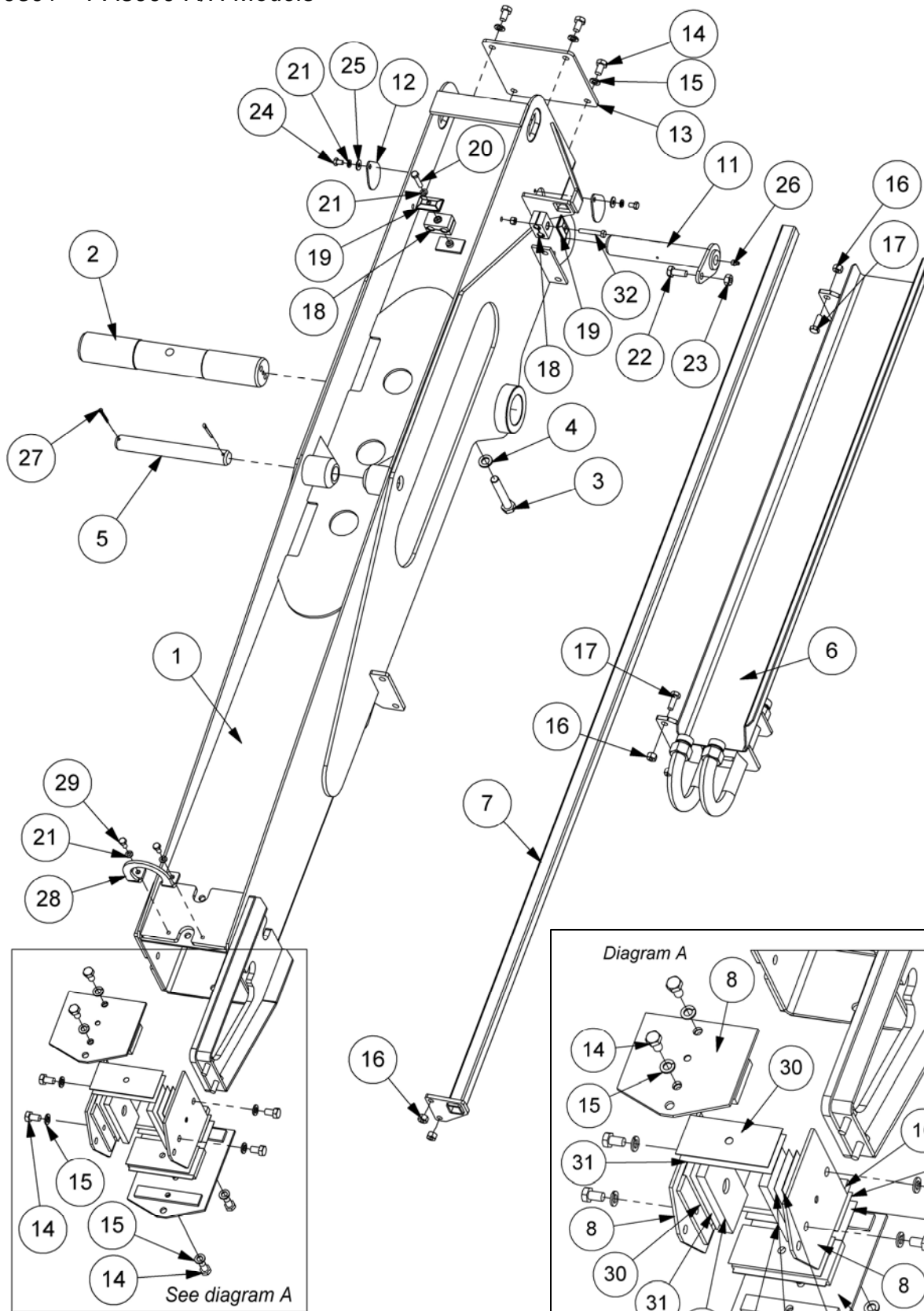

**TELE SOCKET OUTER ASSEMBLY**

REF.	QTY.	PART No.	DESCRIPTION
		<b>7680500</b>	<b>TELE SOCKET OUTER ASSEMBLY - L/H BUILD</b>
		<b>7680501</b>	<b>TELE SOCKET OUTER ASSEMBLY - R/H BUILD</b>
1	1	21023.01	SOCKET UPPER - L/H
	1	21023.02	SOCKET UPPER - R/H ( <i>not illustrated</i> )
2	1	21078.01	MAIN PIVOT PIN
3	1	9213207	BOLT
4	1	9100207	SPRING WASHER
5	1	21092.01	PIN - TELE BASE
6	1	21033.03	HOSE GUIDE BRACKET - L/H
	1	21033.04	HOSE GUIDE BRACKET - R/H ( <i>not illustrated</i> )
7	1	21054.01	GUIDE BOX - L/H
	1	21054.02	GUIDE BOX - R/H ( <i>not illustrated</i> )
8	3	21089.01	PAD CARRIER - SIDE & TOP
9	1	21088.01	PAD CARRIER - BOTTOM
10	5	21087.01	WEAR PAD
11	1	21098.01	PIN - TENSION LINK
12	2	21090.01	ACCESS COVER
13	1	21079.01	COVER PLATE
14	12	9313046	SETSCREW
15	12	9100206	SPRING WASHER
16	6	9143005	SELF-LOCKING NUT
17	4	9313065	SETSCREW
18	2	7193065	HOSE CLAMP (x2)
19	2	7193066	CLAMP PLATE
20	1	9213084	BOLT
21	5	9100204	SPRING WASHER
22	1	9313066	SETSCREW
23	1	9143006	SELF-LOCKING NUT
24	2	9313024	SETSCREW
25	2	9100104	FLAT WASHER
26	1	0901121	GREASE NIPPLE
27	2	9501406	SPLIT PIN
28	1	21052.01	RAM SUPPORT
29	2	9313034	SETSCREW
30	<i>as req'd</i>	21134.01	SHIM - 1.0mm
31	<i>as req'd</i>	21134.02	SHIM - 0.25mm
32	1	9213104	BOLT
33	1	9143004	SELF-LOCKING NUT
34	<i>as req'd</i>	21134.03	SHIM - 1.2MM

*Component parts for Left Hand and Right Hand Builds are identical with the exception of items: 1, 6 & 7*

# TELE SOCKET INNER ASSEMBLY

## MODULES:

7680502 – PA8000 L/H Models

7680503 – PA8000 R/H Models

*Illustrated in Left-Hand build*

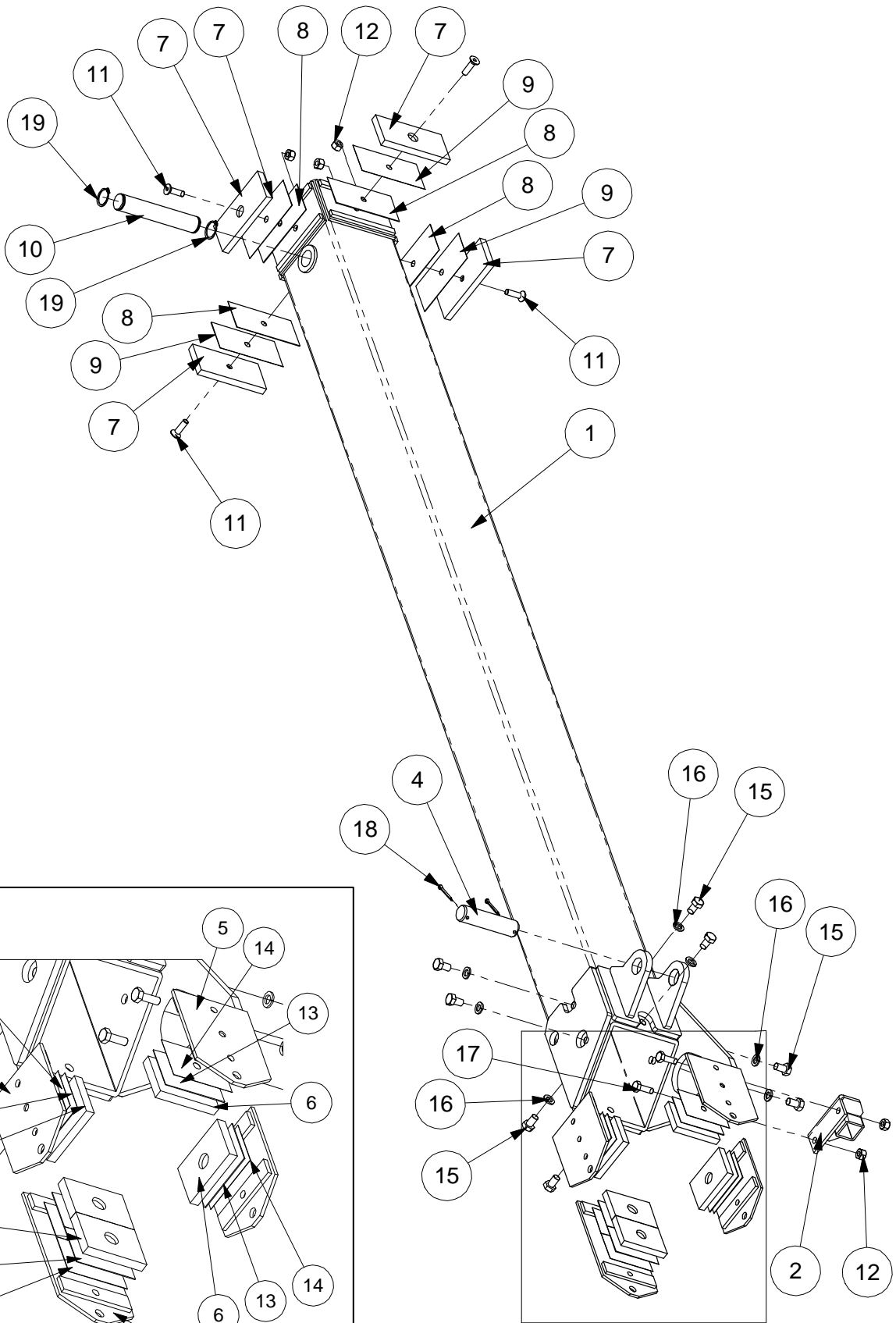

Diagram 'A'

See Diagram 'A'



# TELE SOCKET INNER ASSEMBLY

REF.	QTY.	PART No.	DESCRIPTION
		<b>7680502</b>	<b>TELE SOCKET INNER ASSEMBLY - L/H BUILD</b>
		<b>7680503</b>	<b>TELE SOCKET INNER ASSEMBLY - R/H BUILD</b>
1	1	21022.01	DIPPER CENTRE SOCKET - L/H
	1	21022.02	DIPPER CENTRE SOCKET - R/H ( <i>not illustrated</i> )
2	1	21083.01	SUPPORT BRACKET
3	1	43463.01	PAD CARRIER - BOTTOM
4	1	21091.01	PIN - TELE ROD END
5	3	43463.02	PAD CARRIER - SIDE/TOP
6	5	7136001	DIPPER WEAR STRIP
7	4	21087.01	WEAR PAD
8	<i>as req'd</i>	21134.01	SHIM - 1.0mm
9	<i>as req'd</i>	21134.02	SHIM - 0.25mm
	<i>as req'd</i>	21134.03	SHIM - 1.2mm ( <i>not illustrated</i> )
10	1	21157.01	ROD END PIN
11	4	9353075	CAPSCREW
12	6	9143005	SELF-LOCKING NUT
13	5	7136059	SHIM - 1.0mm
14	5	7136058	SHIM - 0.25mm
15	8	9313046	SETSCREW
16	8	9100206	SPRING WASHER
17	2	9313065	SETSCREW
18	2	9501406	SPLIT PIN
19	2	0401230	CIRCLIP - EXTERNAL

*Component parts for Left Hand and Right Hand Builds are identical with the exception of item: 1*



# HEAD ANGLING MECHANISM

**MODULE:**  
Common to all builds

*Illustrated in Left-Hand build*

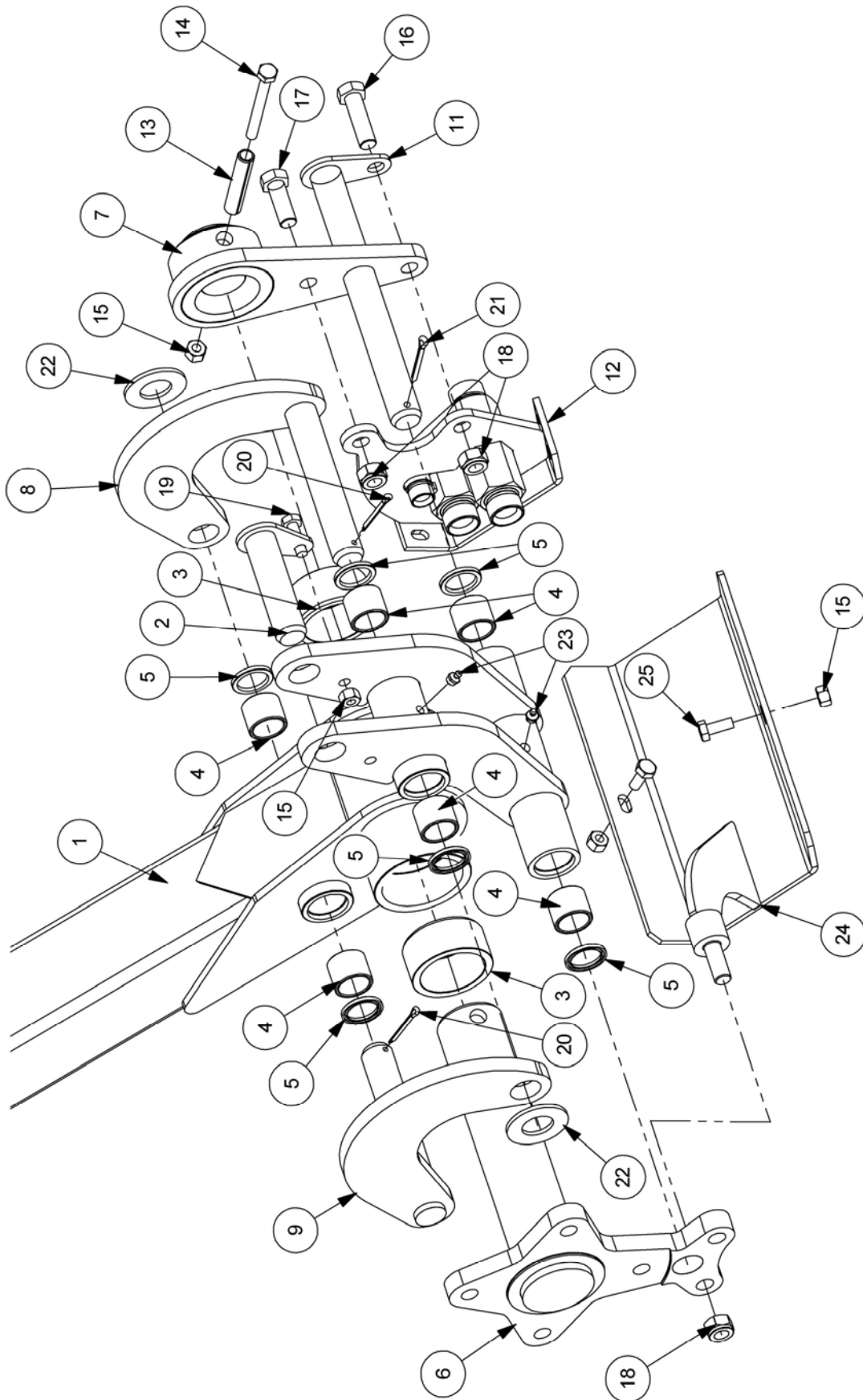



## HEAD ANGLING MECHANISM

REF.	QTY.	PART No.	DESCRIPTION
			<b>HEAD ANGLING MECHANISM ASSEMBLY</b>
1	1	* See below	DIPPER ARM
2	1	42684.05	PIN
3	2	7136035	PLASTIC BUSH
4	6	08.297.04	BUSH
5	6	8629218	LIP SEAL
6	1	21263.01	PIVOT TUBE
7	1	42648.01	JAW PLATE
8	1	42646.04	RADIUS ARM - TYPE 2
9	1	42646.03	RADIUS ARM - TYPE 1
10	1	42647.02	SLAVE LINK
11	1	42684.01	PIN - SLAVE LINK
12	1	21261.03	JUNCTION BRACKET
13	1	0423556	SPRING DOWEL
14	1	9213205	BOLT
15	4	9143005	SELF-LOCKING NUT
16	1	9200023	BOLT
17	1	9200028	BOLT
18	3	9100028	SELF-LOCKING NUT
19	1	9313075	SETSCREW
20	2	9501406	SPLIT PIN
21	1	9501507	SPLIT PIN
22	2	05.281.18	FLAT WASHER
23	3	0901121	GREASE NIPPLE
24	1	21262.01	HOSE TRAY
25	2	9313055	SETSCREW

*The component parts for the Head Angling Mechanism are identical for all builds, assembly of a Right Hand build is a mirror of the Left Hand illustration shown opposite.*

*\* For Dipper Arm part nos. refer to the specific Dipper Arm Assembly page for details.*

# PUMP & GEARBOX ASSEMBLY

## MODULES:

7666530 – L/H Build

7666531 – R/H Build

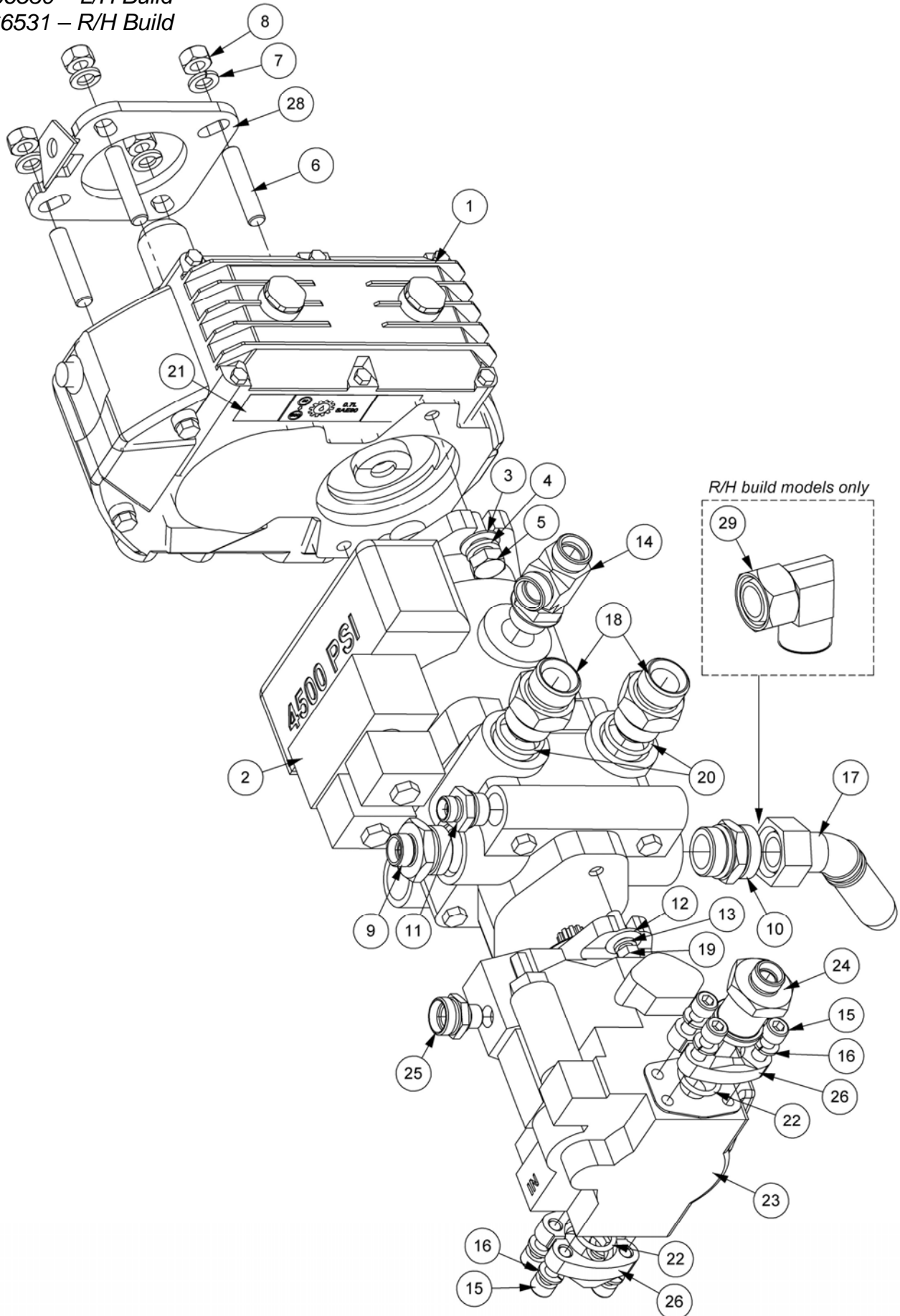

**PUMP & GEARBOX ASSEMBLY**

REF.	QTY.	PART No.	DESCRIPTION
		<b>7666530</b>	<b>PUMP &amp; GEARBOX ASSEMBLY - L/H Build</b>
		<b>7666531</b>	<b>PUMP &amp; GEARBOX ASSEMBLY - R/H Build</b>
1	1	8013513	GEARBOX ASSEMBLY 3:1 15T
2	1	8201716	PISTON PUMP 4500 PSI
3	2	9100020	FLAT WASHER
4	2	05.282.08	SPRING WASHER
5	2	05.839.01	BOLT
6	4	04.282.65	STUD
7	4	9100206	SPRING WASHER
8	4	9113006	NUT
9	1	8581396	ADAPTOR c/w O RING
10	1	8581375	ADAPTOR
11	1	8581394	ADAPTOR
12	2	0100103	FLAT WASHER
13	2	0100203	SPRING WASHER
14	1	8581438	ADAPTOR
15	8	9343065	CAPSCREW
16	8	9100205	SPRING WASHER
17	1	8581407	ADAPTOR (HOSE TAIL)
18	2	8581256	ADAPTOR
19	2	0312103	HEX SCREW
20	2	8600916	O RING
21	1	1290092	GEARBOX DECAL
22	2	8600119	O RING
23	1	8201707	PISTON PUMP
24	1	8581439	ADAPTOR
25	1	8581406	ADAPTOR
26	2	41.294.02	SPLIT FLANGE
27	1	43177.27	LOOM - <i>not illustrated</i>
28	1	21208.01	BACKING PLATE
29	1	8581376	ADAPTOR ELBOW (90°) - <i>R/H Build only</i>

# GEARBOX ASSEMBLY

			<b>SAE75W90</b> <b>0.7L</b> <b>FULLY SYNTHETIC</b>	
--	--	--	--	--

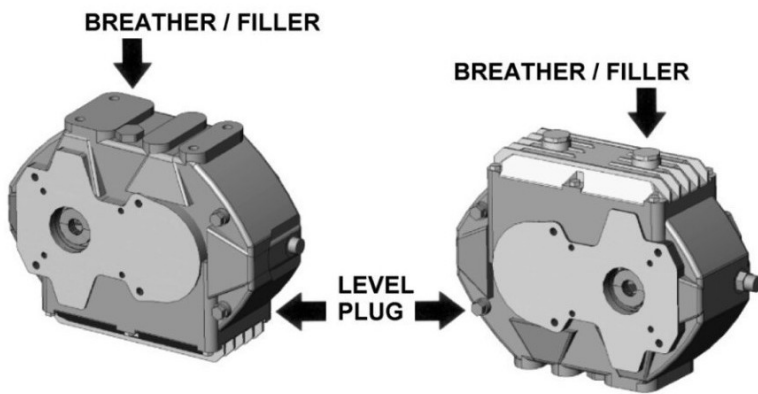
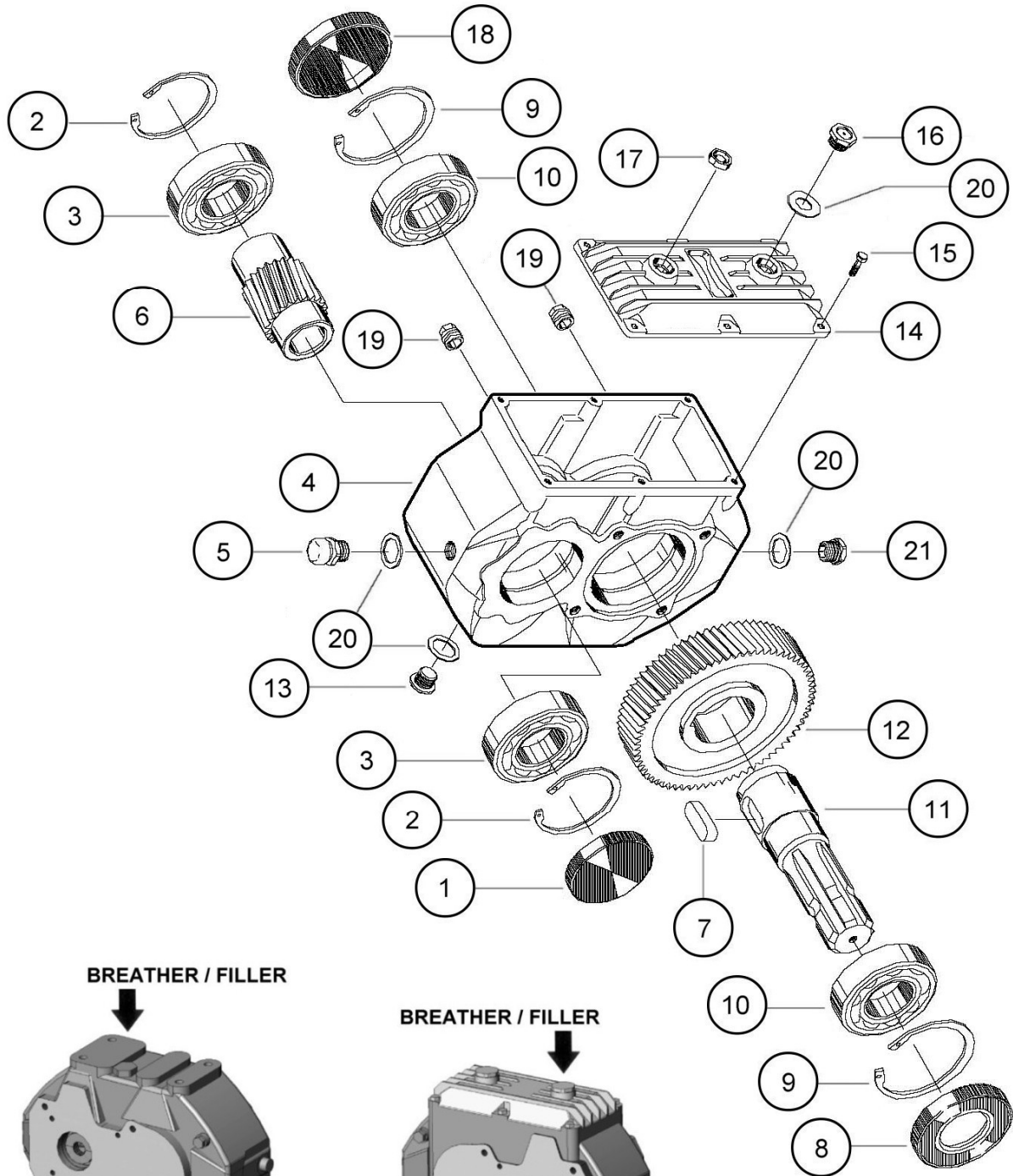

*NOTE: Plug positions are dependent on gearbox orientation*

**GEARBOX ASSEMBLY**

REF.	QTY.	PART No.	DESCRIPTION
		<b>8013513</b>	<b>GEARBOX ASSEMBLY (Cast Iron)</b> <i>Specification: Ratio 3:1 with 15 tooth spline</i>
1	1	8013530	CAP
2	2	8013529	CIRCLIP
3	2	8013574	BEARING
4	1	8013598	HOUSING
5	1	8013590	OIL PLUG
6	1	8013549	SHAFT
7	1	8013586	KEY
8	1	8013526	OIL SEAL
9	2	8013525	CIRCLIP
10	2	8013524	BEARING
11	1	8013522	INPUT SHAFT
12	1	8013569	GEAR
13	1	8013593	OIL PLUG
14	1	8013521	COVER
15	6	9313033	SCREW
16	1	8013599	OIL PLUG
17	1	8013535	OIL PLUG
18	1	8013527	CAP
19	2	8013588	OIL PLUG
20	4	8013591	WASHER
21	2	8013533	OIL PLUG

# CONTROL VALVE - STANDARD

MODULE:  
8130664

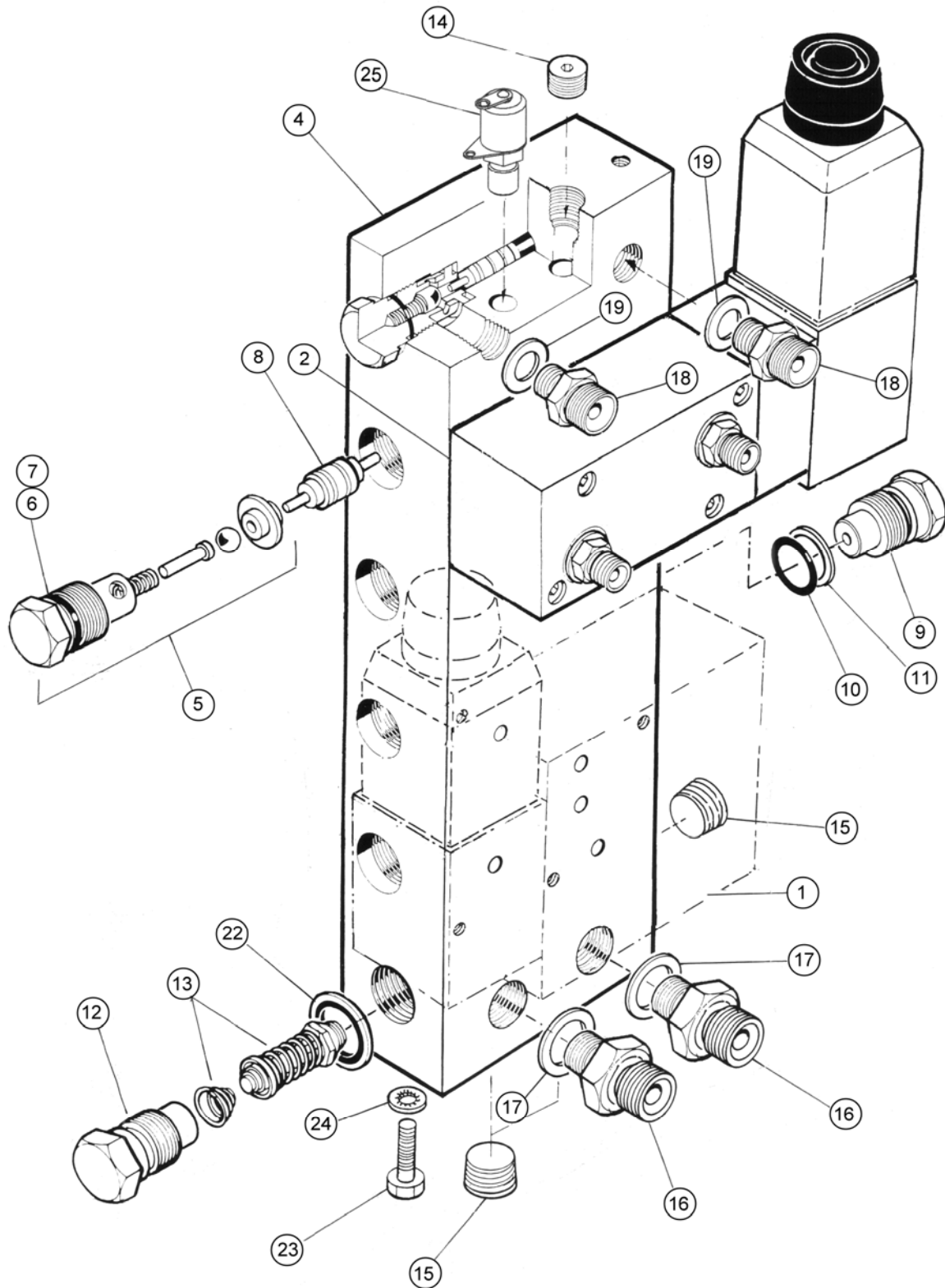

**CONTROL VALVE - STANDARD**

REF.	QTY.	PART No.	DESCRIPTION
		<b>8130664</b>	<b>CONTROL VALVE - STANDARD ARM MODELS</b>
1	1		SLEW VALVE
2	1		ANGLE FLOAT VALVE
3	1		SOLENOIDS - <i>not illustrated</i>
4	1	8132280	MANIFOLD BLOCK
5	7	8130090	CHECK VALVE ASSEMBLY
6	1	8700644	CHECK VALVE O RING
7	1	8709644	CHECK VALVE ANTI EXTRUSION RING
8	5	8130087	ACTUATOR
9	1	8130078	CHECK VALVE BLANK
10	1	8700644	O RING
11	1	8709644	ANTI EXTRUSION RING
12	1	8130032	RELIEF VALVE CAP
13	1	8130029	RELIEF VALVE c/w SPRING (175 BAR)
14	1	8582042	TAPER PLUG
15	3	8582043	TAPER PLUG
16	2	8581391	ADAPTOR <i>inc. Seal</i>
17	2	8650403	SEAL
18	2	8581390	ADAPTOR <i>inc. Seal</i>
19	1	8650402	SEAL
20	2	8581374	ADAPTOR <i>inc. Seal</i>
21	1	8650402	SEAL
22	1	8650103	BONDED SEAL
23	2	9313055	SETSCREW
24	2	9100205	INTERNAL SHAKEPROOF WASHER
25	1	8131008	PRESSURE TEST POINT
		<b>8699197</b>	<b>SEAL KIT</b>



# CONTROL VALVE - TELE/MIDCUT

MODULE:  
8130663

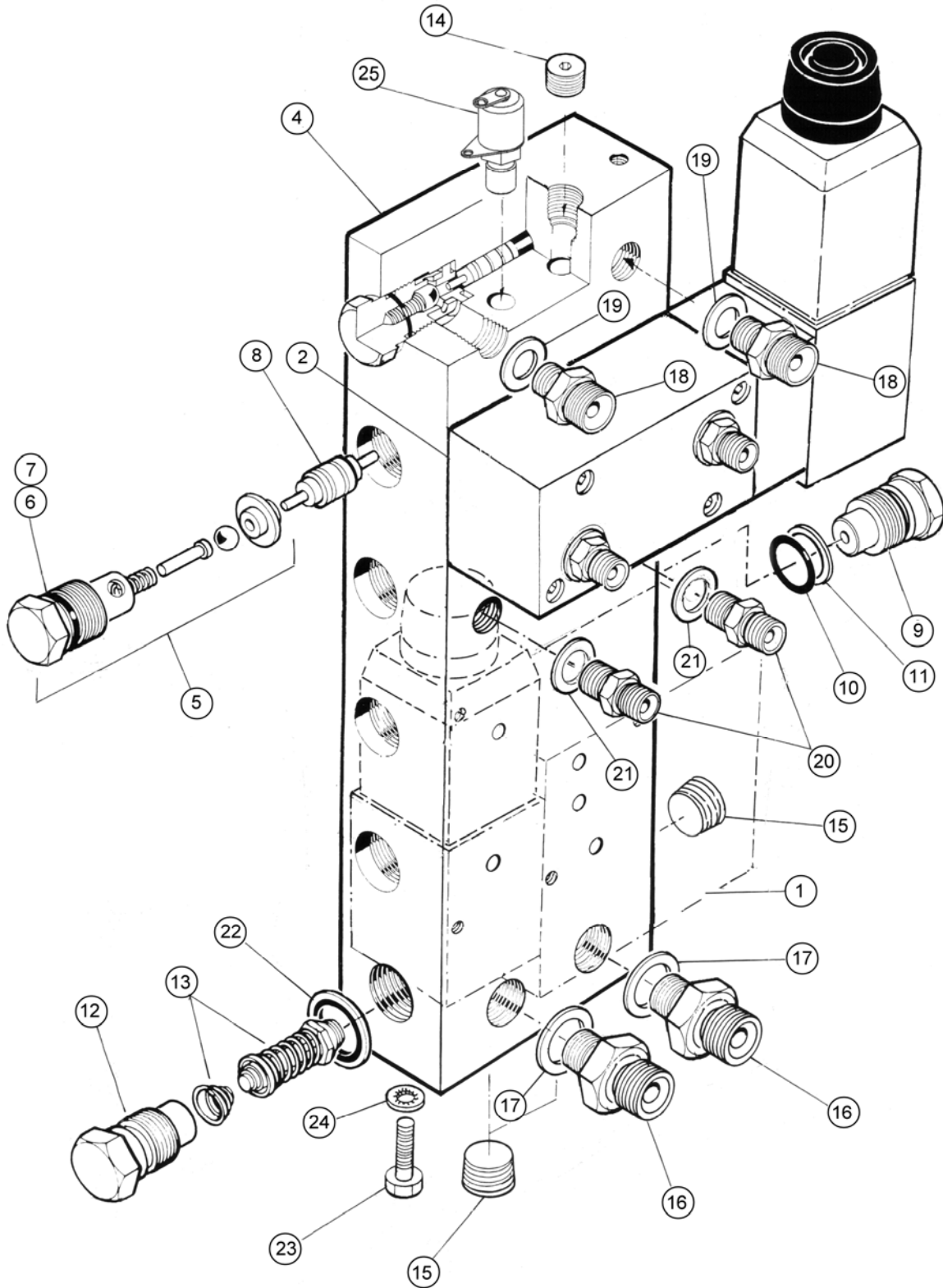



**CONTROL VALVE - TELE / MIDCUT**

REF.	QTY.	PART No.	DESCRIPTION
		<b>8130663</b>	<b>CONTROL VALVE - TELE ARM / MIDCUT ARM</b>
1	1		SLEW VALVE
2	1		ANGLE FLOAT VALVE
3	1		SOLENOIDS - <i>not illustrated</i>
4	1	8132281	MANIFOLD BLOCK - 5 SERVICE
5	7	8130090	CHECK VALVE ASSEMBLY
6	1	8700644	CHECK VALVE O RING
7	1	8709644	CHECK VALVE ANTI EXTRUSION RING
8	5	8130087	ACTUATOR
9	1	8130078	CHECK VALVE BLANK
10	1	8700644	O RING
11	1	8709644	ANTI EXTRUSION RING
12	1	8130032	RELIEF VALVE CAP
13	1	8130206	RELIEF VALVE c/w SPRING (250 BAR)
14	1	8582042	TAPER PLUG
15	3	8582043	TAPER PLUG
16	2	8581391	ADAPTOR <i>inc. Seal</i>
17	2	8650403	SEAL
18	2	8581390	ADAPTOR <i>inc. Seal</i>
19	1	8650402	SEAL
20	2	8581374	ADAPTOR <i>inc. Seal</i>
21	1	8650402	SEAL
22	1	8650103	BONDED SEAL
23	2	9313055	SETSCREW
24	2	9100205	INTERNAL SHAKEPROOF WASHER
25	1	8131008	PRESSURE TEST POINT
		<b>8699197</b>	<b>SEAL KIT</b>

# SOLENOIDS ASSEMBLY

## MODULE:

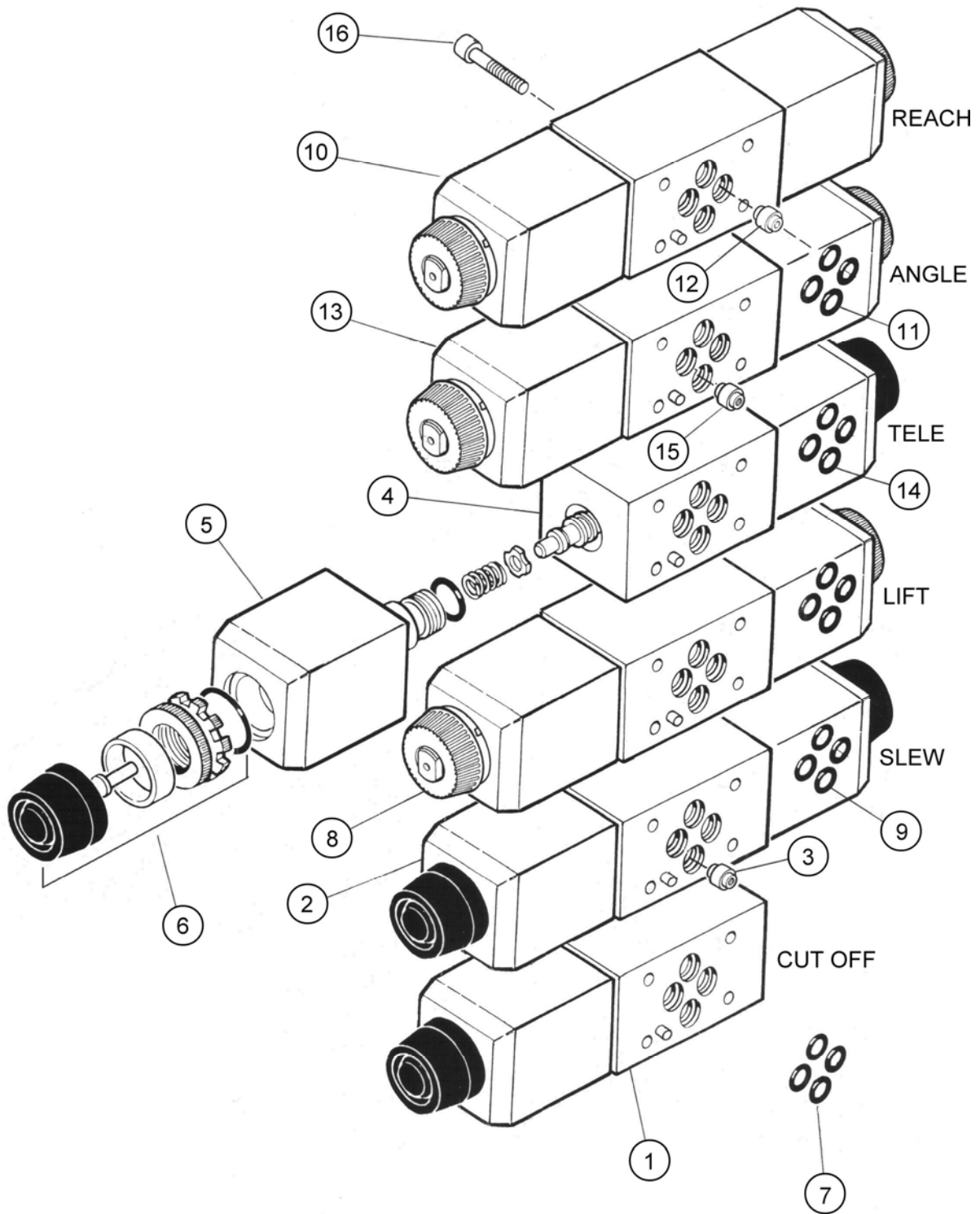
Sub-Assembly of 8130663 (Revision G)





## SOLENOIDS ASSEMBLY

REF.	QTY.	PART No.	DESCRIPTION
<b>SERVICE SOLENOIDS</b>			
1	1	8130456	SINGLE SOLENOID - STANDARD - CUT OFF
2	1	8130629	DOUBLE SOLENOID - STANDARD - SLEW
3	1	42989.05	RESTRICTOR INSERT
4	1	8130629	DOUBLE SOLENOID - STANDARD - TELE/MIDCUT *

\* if fitted

**Items 5, 6 & 7 are common to all standard solenoid valves**

5	1	8130175	COIL
6	1	8130176	MANUAL OVER-RIDE KIT
7	4	8600107	O RING
8	1	41784.31	DOUBLE SOLENOID - PROPORTIONAL - LIFT
9	4	8600107	O RING
10	1	41784.31	DOUBLE SOLENOID - PROPORTIONAL - REACH
11	4	8600107	O RING
12	1	42989.08	RESTRICTOR INSERT
13	1	41784.31	DOUBLE SOLENOID - PROPORTIONAL - ANGLE
14	4	8600107	O RING
15	1	42989.05	RESTRICTOR INSERT

**Item 16 is common to all solenoid valves**

16	24	9243062	CAPSCREW - SOCKET HEADED
----	----	---------	--------------------------

# SLEW VALVE ASSEMBLY

**MODULE:**

Sub-Assembly of 8130663

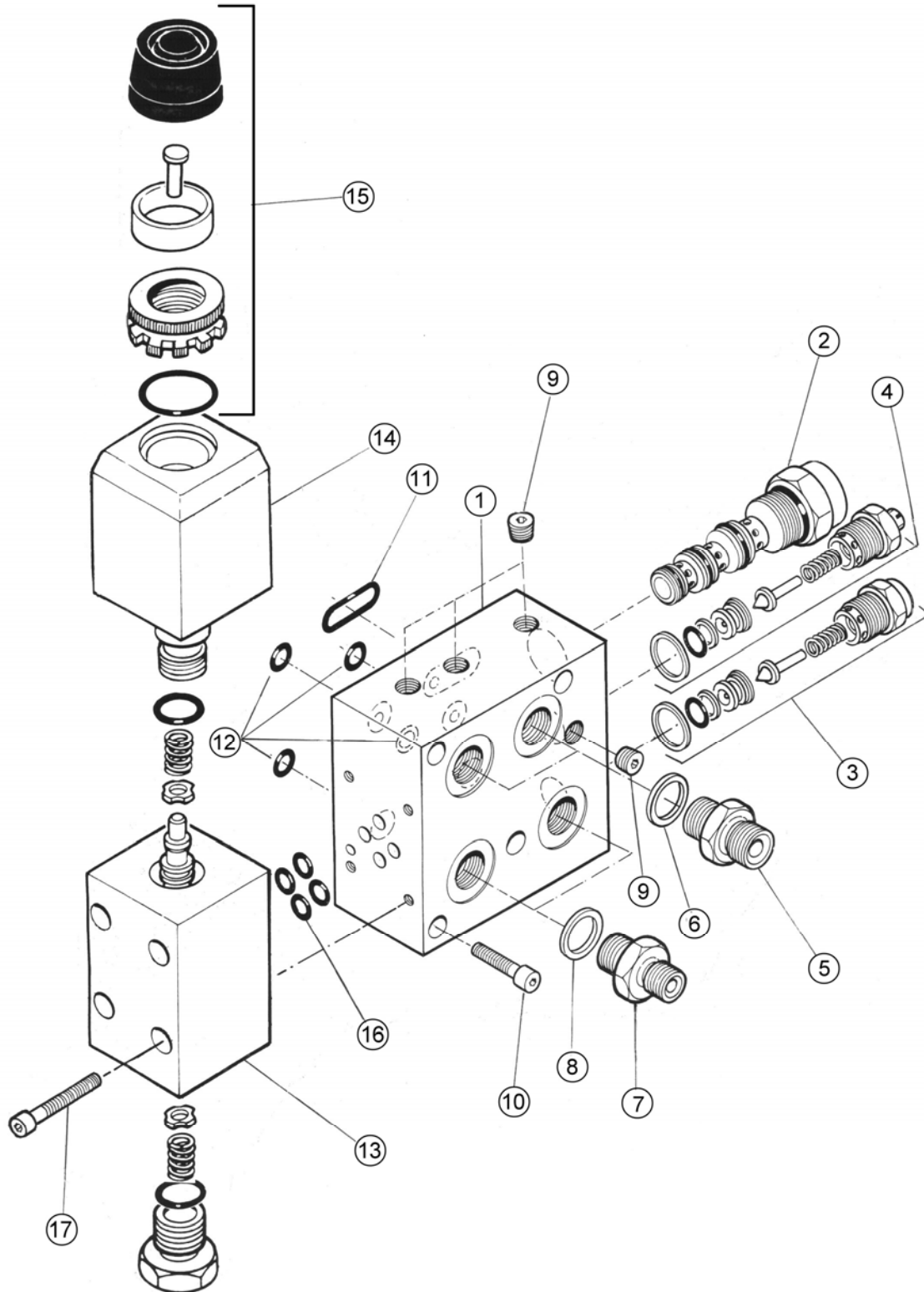



## SLEW VALVE ASSEMBLY

REF.	QTY.	PART No.	DESCRIPTION
			<b>SLEW VALVE ASSEMBLY</b>
1	1	8132279	VALVE BLOCK
2	1	8130204	THREE WAY SPOOL VALVE
3	1	8128022	RELIEF VALVE (175 BAR) - SLEW BASE
4	1	8128065	RELIEF VALVE (40 BAR) - LIFT GLAND
5	2	8581370	ADAPTOR <i>including Seal:-</i>
6	1	8650403	SEAL
7	2	8581368	ADAPTOR <i>including Seal:-</i>
8	1	8650403	SEAL
9	4	8582041	TAPER PLUG
10	4	9243062	CAPSCREW
11	1	8700525	O RING
12	4	8700511	O RING
13	1	8130457	SINGLE SOLENOID VALVE <i>including:-</i>
14	1	8130175	COIL
15	1	8130176	MANUAL OVER-RIDE KIT
16	4	8600107	O RING
17	4	9243082	CAPSCREW - SOCKET HEADED
		<b>8699224</b>	<b>SOLENOID SEAL KIT</b>

# PUMP BY-PASS ASSEMBLY

MODULE:  
42783.04

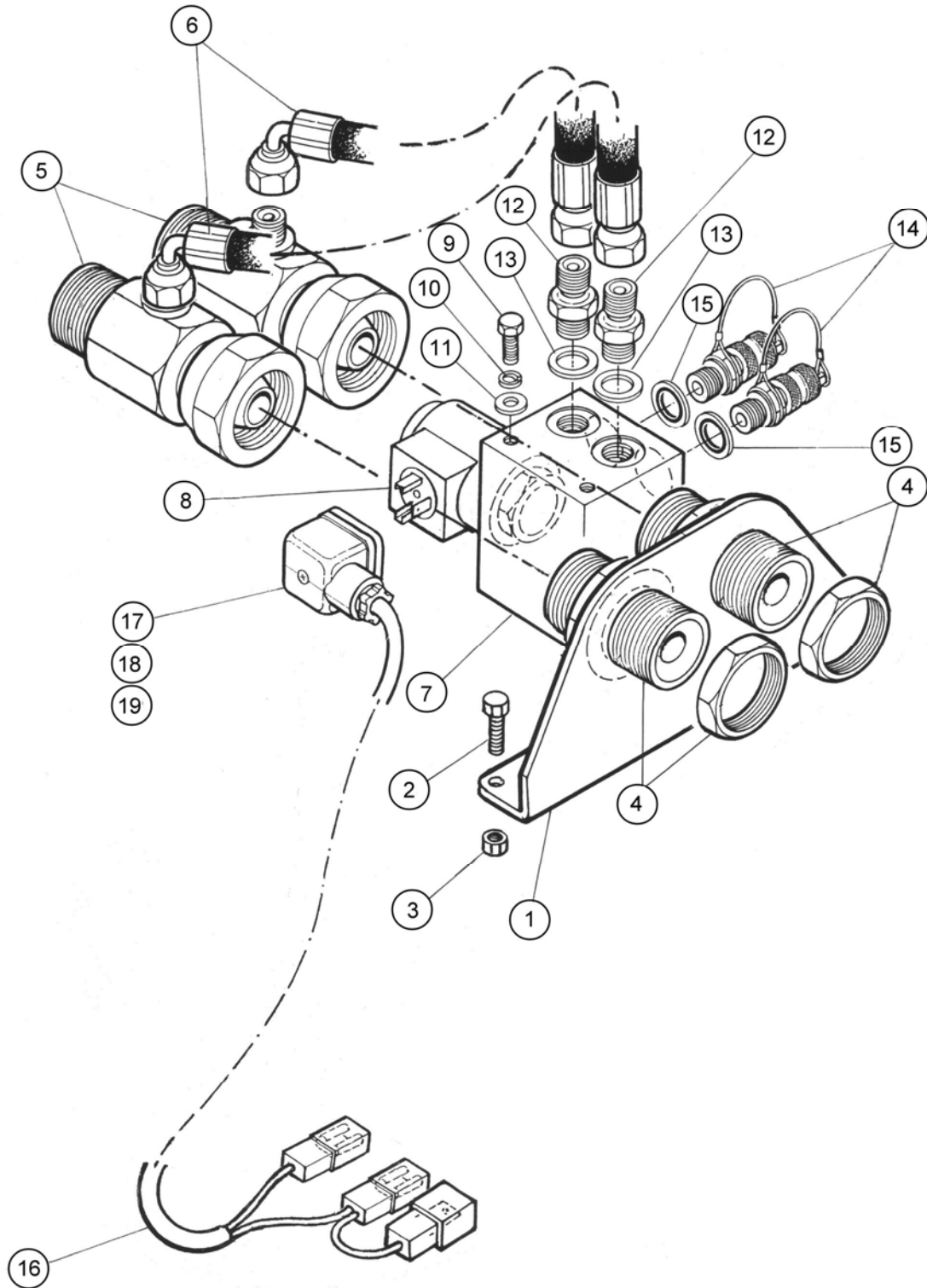



**PUMP BY-PASS ASSEMBLY**

REF.	QTY.	PART No.	DESCRIPTION
		<b>42783.04</b>	<b>PUMP BY-PASS ASSEMBLY</b>
1	1	43386.01	MOUNTING BRACKET
2	2	9313044	SETSCREW
3	2	9143004	SELF-LOCKING NUT
4	2	8581399	BULKHEAD UNION - INCLUDING LOCKNUT
5	2	8581398	ADAPTOR - STRAIGHT SWIVEL
6	2	42718.06	HOSE M14 x 300mm LONG
7	1	8132270	VALVE BLOCK
8	1	8130192	SOLENOID VALVE
9	2	9313034	SETSCREW
10	2	9100204	SPRING WASHER
11	2	9100104	PLAIN WASHER
12	2	8581374	ADAPTOR - INCLUDING SEAL
13	1	8650402	SEAL
14	2	8130008	TEST POINT UNION
15	2	8650102	BONDED SEAL
16	1	43177.29	LOOM - INCLUDING PLUG
17	1	07.835.04	PLUG - INCLUDING SCREW & GASKET
18	1	07.835.05	SCREW
19	1	07.835.02	GASKET

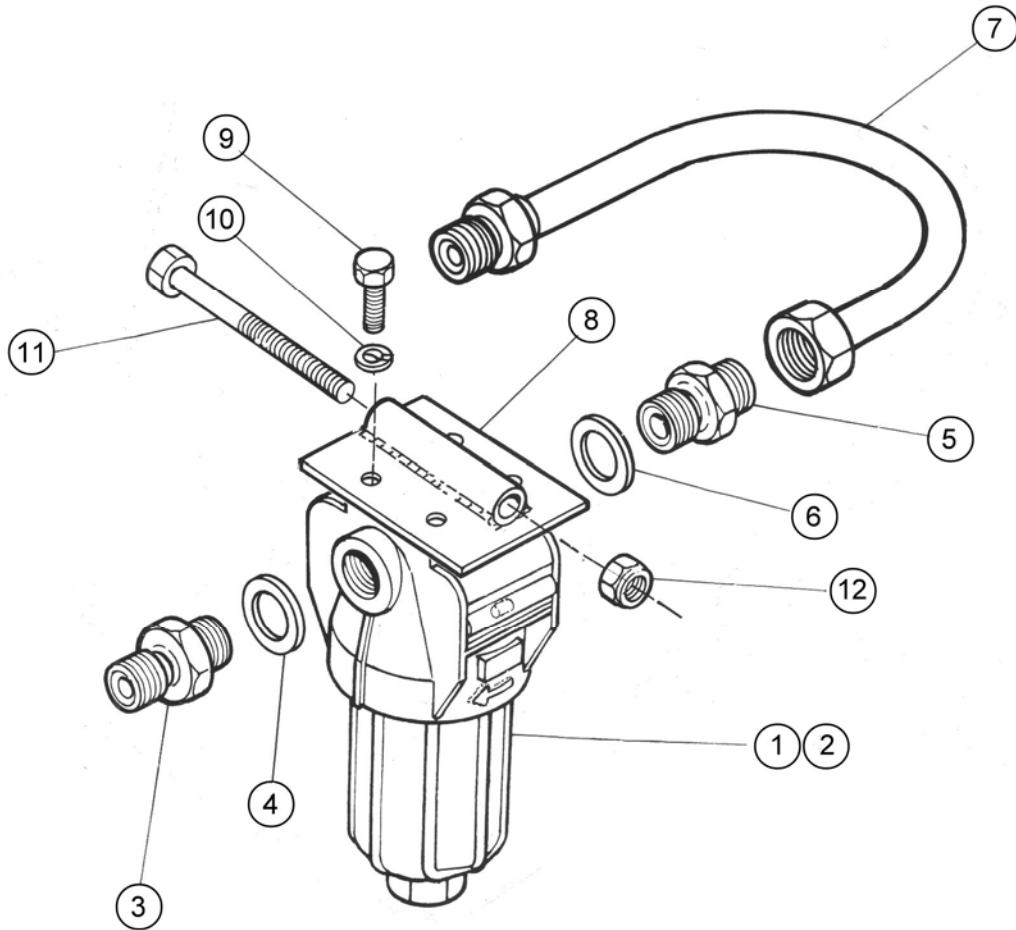

# CHARGE FILTER ASSEMBLY

MODULE:  
42782.02



**CHARGE FILTER ASSEMBLY**

REF.	QTY.	PART No.	DESCRIPTION
		<b>42782.02</b>	<b>CHARGE FILTER ASSEMBLY</b>
1	1	8401066	CHARGE FILTER - INCLUDING ELEMENT
2	1	8401067	ELEMENT
3	1	8581386	ADAPTOR - INCLUDING SEAL
4	1	8650404	SEAL
5	1	G3812674	ADAPTOR - INCLUDING SEAL
6	1	8650404	SEAL
7	1	42782.31	U-BEND
8	1	43388.01	MOUNTING BRACKET
9	4	9313023	SETSCREW
10	4	9100203	SPRING WASHER
11	1	9213225	BOLT
12	1	9143005	SELF-LOCKING NUT

# MIDCUT RELIEF ASSEMBLY

MODULE:  
7455810

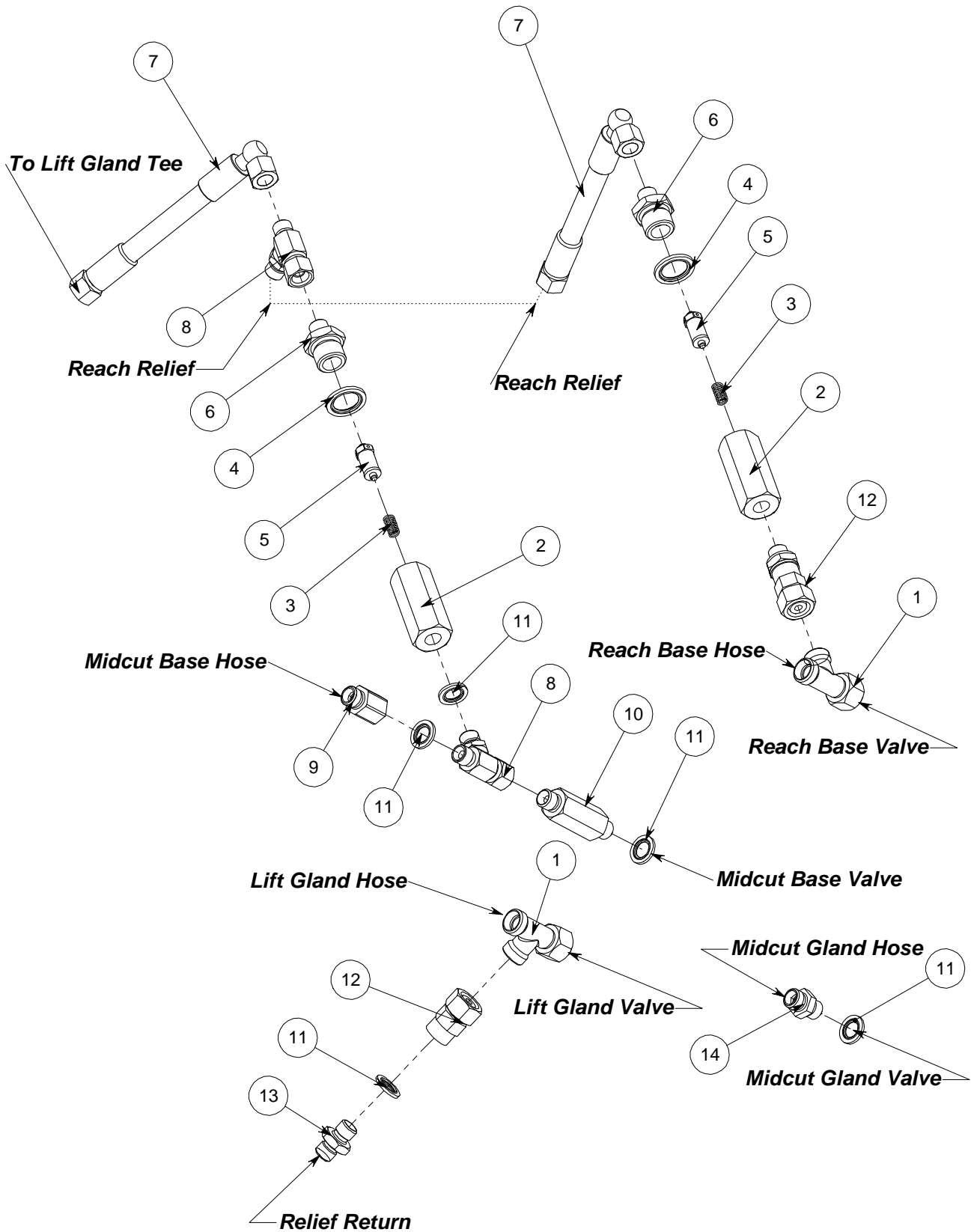

**MIDCUT RELIEF ASSEMBLY**

<b>REF.</b>	<b>QTY.</b>	<b>PART No.</b>	<b>DESCRIPTION</b>
		<b>7455810</b>	<b>MIDCUT RELIEF ASSEMBLY</b>
1	2	8581413	ADAPTOR TEE
2	2	8130156	ADAPTOR RELIEF HOUSING
3	2	8116011	SPRING
4	2	8650104	BONDED SEAL
5	2	8130092	RELIEF VALVE - 190BAR
6	2	8130083	ADAPTOR RELIEF BODY
7	2	10.002.08	HOSE - 1/4" BSP FS/F90 x 400mm
8	2	8581254	ADAPTOR TEE
9	1	8581360	ADAPTOR
10	1	8581279	ADAPTOR
11	7	8650102	BONDED SEAL
12	2	8581433	ADAPTOR - SWIVEL
13	2	8581169	ADAPTOR
14	1	8124134	ADAPTOR RESTRICTOR

# OIL COOLER ASSEMBLY

**MODULES:**

7680519 – L/H Build

7680520 – R/H Build

*Illustrated in Left-Hand build*

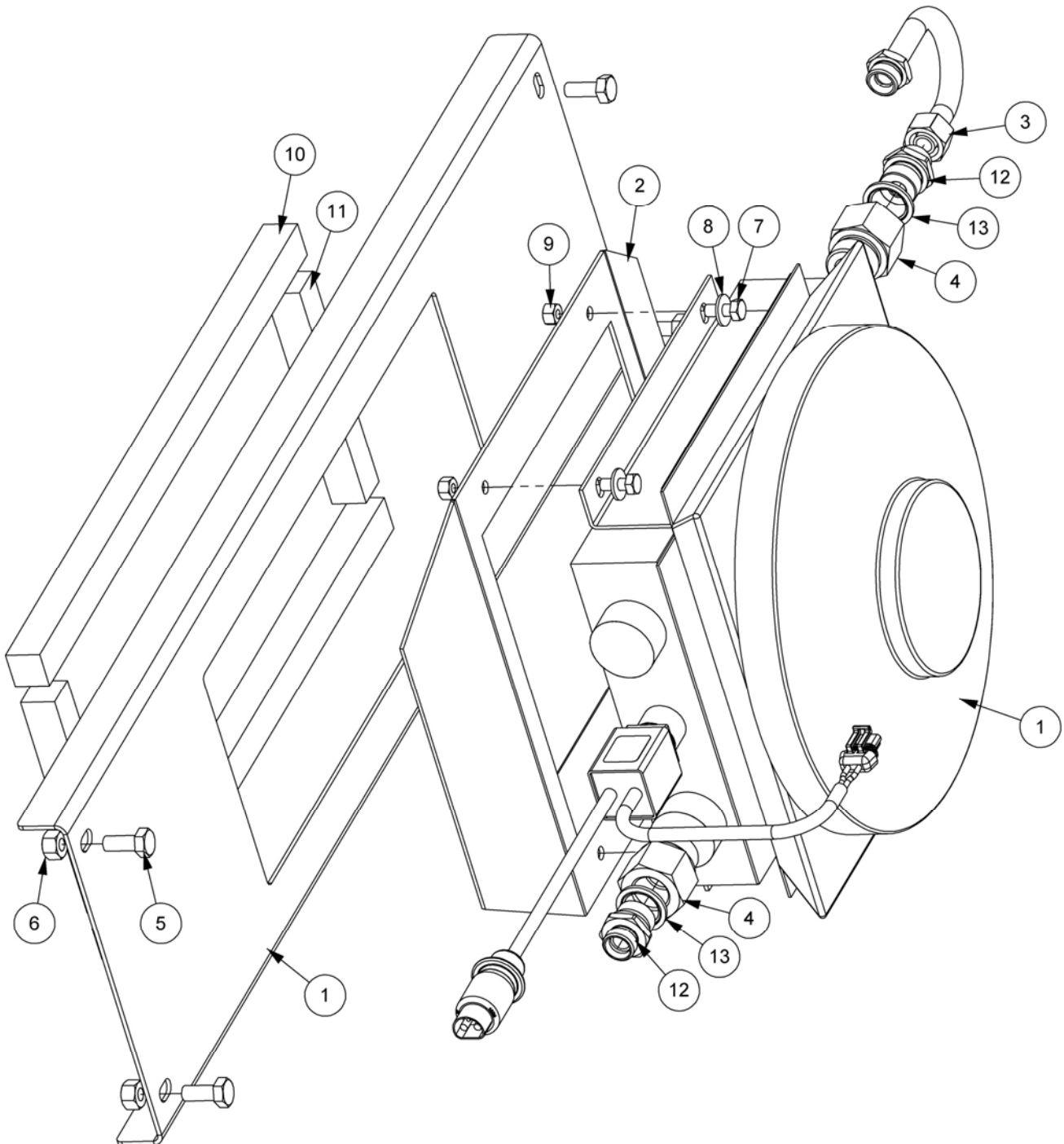

**OIL COOLER ASSEMBLY**

REF.	QTY.	PART No.	DESCRIPTION
		<b>7680519</b>	<b>COOLER ASSEMBLY - L/H Build</b>
		<b>7680520</b>	<b>COOLER ASSEMBLY - R/H Build</b>
1	1	8402379	COOLER c/w THERMO SWITCH AND LOOM
2	1	21064.01	COOLER MOUNT
3	1	42782.31	PIPE (U BEND)
4	2	8581414	ADAPTOR
5	4	9313055	SETSCREW
6	4	9143005	SELF-LOCKING NUT
7	4	9313044	SETSCREW
8	4	9100104	FLAT WASHER
9	4	9143004	SELF-LOCKING NUT
10	2	42713.07	FOAM STRIP - 500mm
11	2	42713.09	FOAM STRIP - 170mm
12	2	8581364	ADAPTOR
13	2	8650106	BONDED SEAL

**NOTE: L/H & R/H builds contain identical parts and differ only in their assembled positions**

# COOLER BYPASS KIT

Module:  
7756529

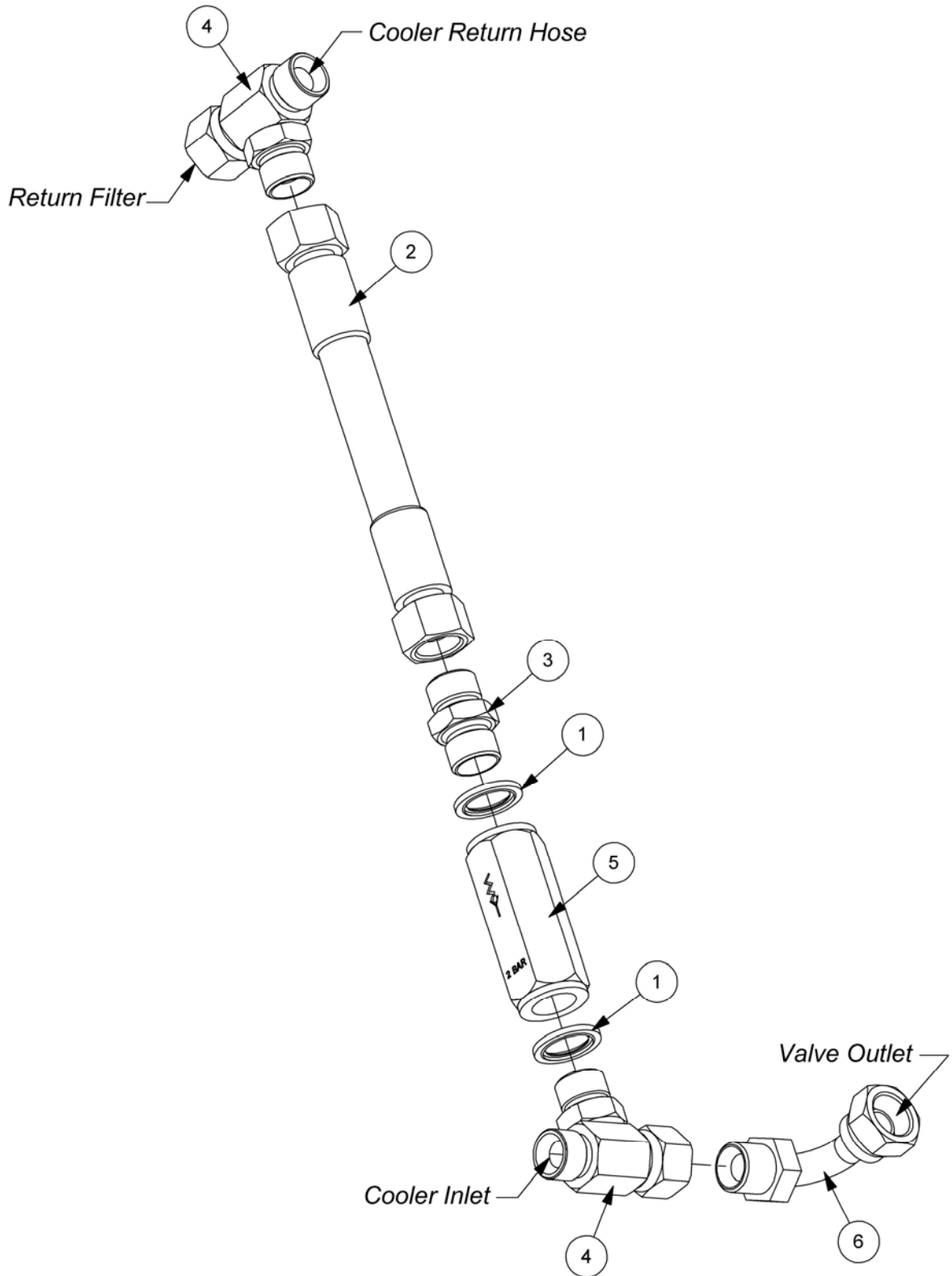

**COOLER BYPASS KIT**

REF.	QTY.	PART NO.	DESCRIPTION
		<b>7756529</b>	<b>COOLER BYPASS KIT - Piston Machines</b>
1	2	8650104	BONDED SEAL
2	1	10.005.06	HOSE - 1/2" BSP FS/FS x 300mm
3	1	8581110	ADAPTOR
4	2	8581296	TEE ADAPTOR
5	1	8130694	CHECK VALVE - 2.0 BAR
6	1	8581215	SWEPT ADAPTOR - 90°



# CONTROL VALVE HOSES

**MODULE:**

8130663 - Tele/Midcut Arm

8130664 - Standard Arm

**Standard Arm Control Valve (8130664)  
Hydraulic Hose Installation**

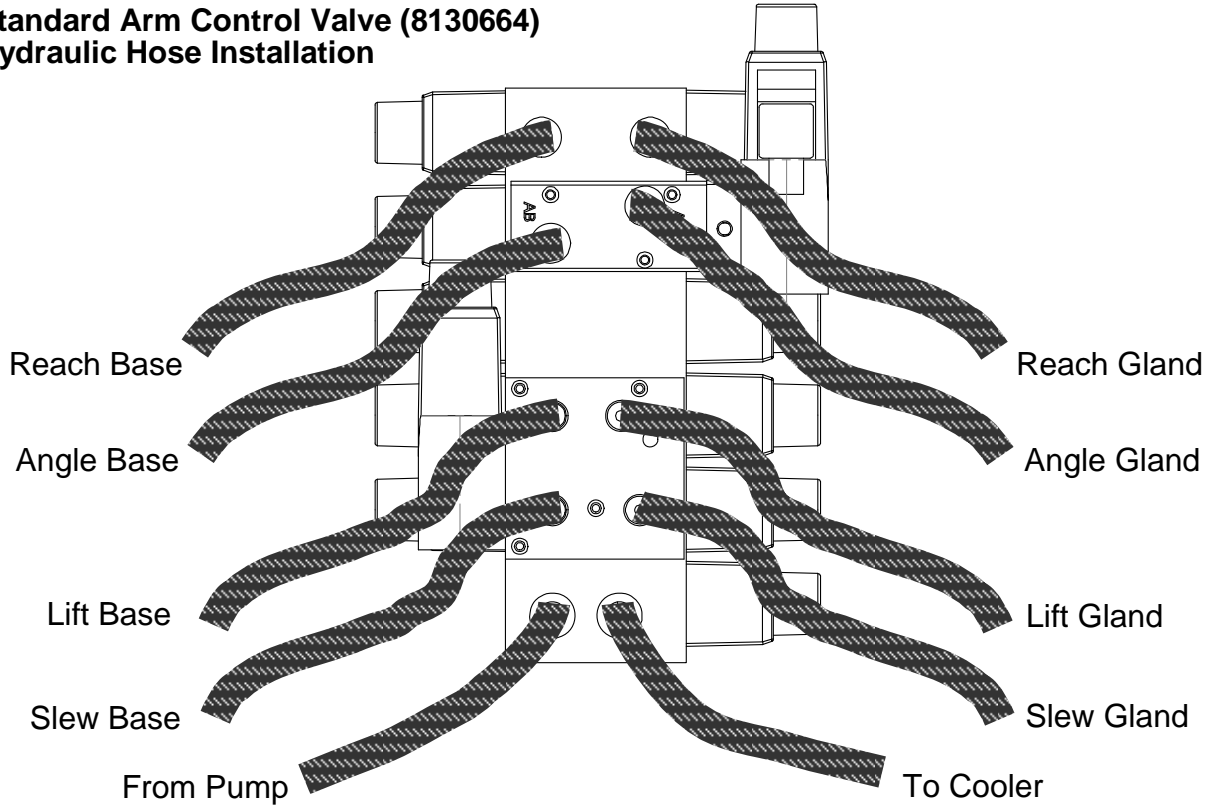

**Tele/Midcut Arm Control Valve (8130663)  
Hydraulic Hose Installation**

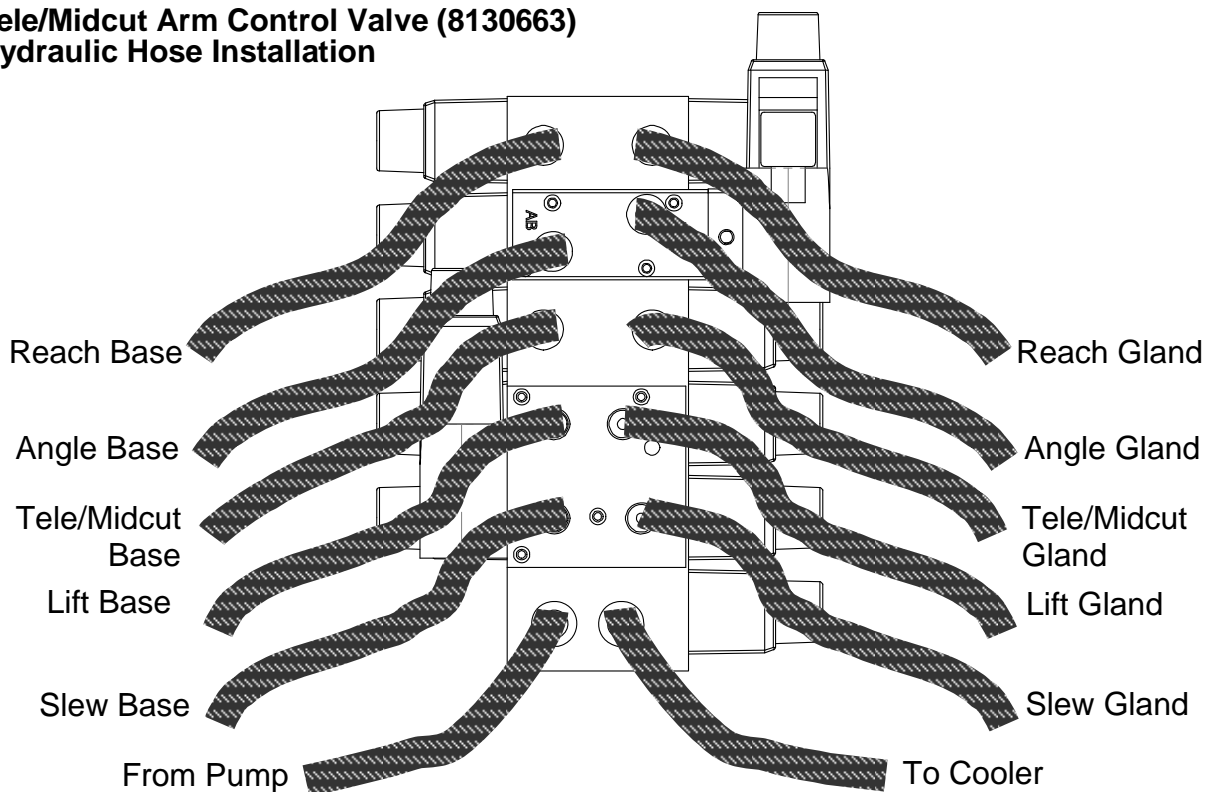

**CONTROL VALVE HOSES**

<b>HOSE SERVICE</b>	<b>PART No.</b>	<b>DESCRIPTION</b>
REACH BASE REACH GLAND	} 42720.50	HOSE - M18 FS/FS x 4000mm
ANGLE BASE ANGLE GLAND	} 42717.41	HOSE - M14 FS/FS x 3100mm
LIFT BASE LIFT GLAND	} 42721.25	HOSE - M18 FS/F90 x 1500mm
TELE/MIDCUT BASE TELE/MIDCUT GLAND	} 42717.46	HOSE - M14 FS/FS x 3600mm
SLEW BASE SLEW GLAND	} 42718.14	HOSE - M14 FS/F90 x 700mm
FROM PUMP TO COOLER	} 42724.11	HOSE - M22 FS/F90 x 550mm

# HOSE INSTALLATION-TELE ARM

**MODULES:**  
76667221

*Illustrated in Left Hand build*

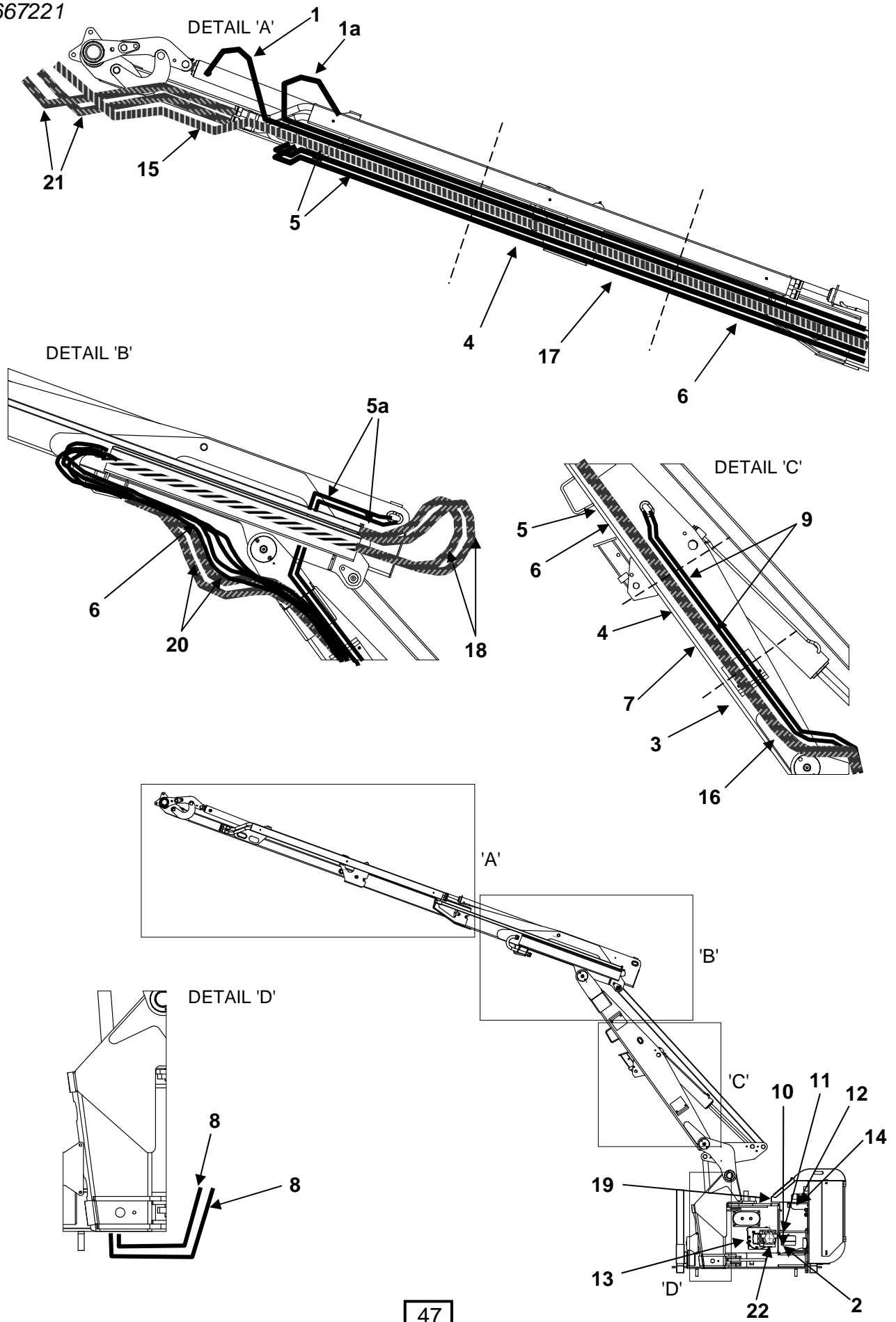



## HOSE INSTALLATION-TELE ARM

REF.	QTY.	PART No.	DESCRIPTION
		<b>76667223</b>	<b>HOSE KIT - PA 8000 L/H &amp; R/H</b>
1	1	42717.23	HOSE - M14 FS/FS x 1300mm
1a	1	42717.25	HOSE - M14 FS/FS x 1500mm
2	2	42718.14	HOSE - M14 FS/F90 x 700mm
3	2	42717.41	HOSE - M14 FS/FS x 3100mm
4	2	42717.70	HOSE - M14 FS/FS x 6000mm
5	2	42717.34	HOSE - M14 FS/FS x 2400mm
5a	2	42717.37	HOSE - M14 FS/FS x 2700mm
6	2	42717.63	HOSE - M14 FS/FS x 5300mm
7	2	42717.46	HOSE - M14 FS/FS x 3600mm
8	2	42721.25	HOSE - M18 FS/F90 x 1500mm
9	2	42720.50	HOSE - M18 FS/FS x 4000mm
10	1	42721.10	HOSE - M18 FS/F90 x 500mm
11	3	42724.11	HOSE - M22 FS/F90 x 550mm
12	1	42724.21	HOSE - M22 FS/F90 x 1100mm
13	1	42727.09	HOSE - M26 FS/F90 x 450mm
14	1	42726.11	HOSE - M26 FS/F90 x 550mm
15	1	10.008.30	HOSE - 5/8" BSP FS/F90 x 2000mm
16	1	42727.39	HOSE - M26 FS/F90 x 2900mm
17	1	42726.66	HOSE - M26 FS/FS x 5600mm
18	2	21270.30	HOSE - 1" BSP EFLEX5000 FS/F135 x 2000mm
19	2	21270.12	HOSE - 1" BSP EFLEX5000 FS/F135 x 600mm
20	2	21269.55	HOSE - 1" BSP EFLEX5000 FS/FS x 4500mm
21	2	21268.18	HOSE - 1" BSP EFLEX5000 FS/F90 x 900mm
22	1	8501312	FLANGE 3/4" SAE 90 x 1" FS

### HOSE LOCATIONS

<b>1</b> Angle - Gland to Union	<b>11</b> Control Pump to Armhead Valve
<b>1a</b> Angle - Base to Union	<b>11</b> Flail Pump to Charge Filter
<b>2</b> Slew Base/Gland	<b>12</b> Cooler to Return
<b>3</b> Angle - Valve to Union	<b>13</b> Drain Line Control Pump to Flail Pump Tee
<b>4</b> Angle - Union to Union	<b>14</b> Drain Line Flail Pump Tee to Tank
<b>5</b> Tele Dipper to 1st Ram	<b>15</b> DrainLine - Dipper to Pivot
<b>5a</b> Tele Main Arm Tee to 2nd Ram	<b>16</b> Drain Line - Tank to Main Arm
<b>6</b> Tele Main Arm Tee to Dipper	<b>17</b> Drain Line - Dipper to Main Arm
<b>7</b> Tele Valve to Main Arm Tee	<b>18</b> Rigid Pipes to Rigid Pipes
<b>8</b> Lift Base/Gland	<b>19</b> Pump to Bulkhead Adaptor
<b>9</b> Reach Base/Gland	<b>20</b> Bulkhead Adaptor to Rigid Pipes
<b>10</b> Charge Filter to Flail Pump	<b>21</b> Flail Rigid Pipes to Junction Bracket
<b>11</b> Armhead Valve Return to Cooler	<b>22</b> Tank to Control Pump



**MODULE:**



**MODULE:**

**ANGLING RAM ASSEMBLY****MODULE:**

21106.01

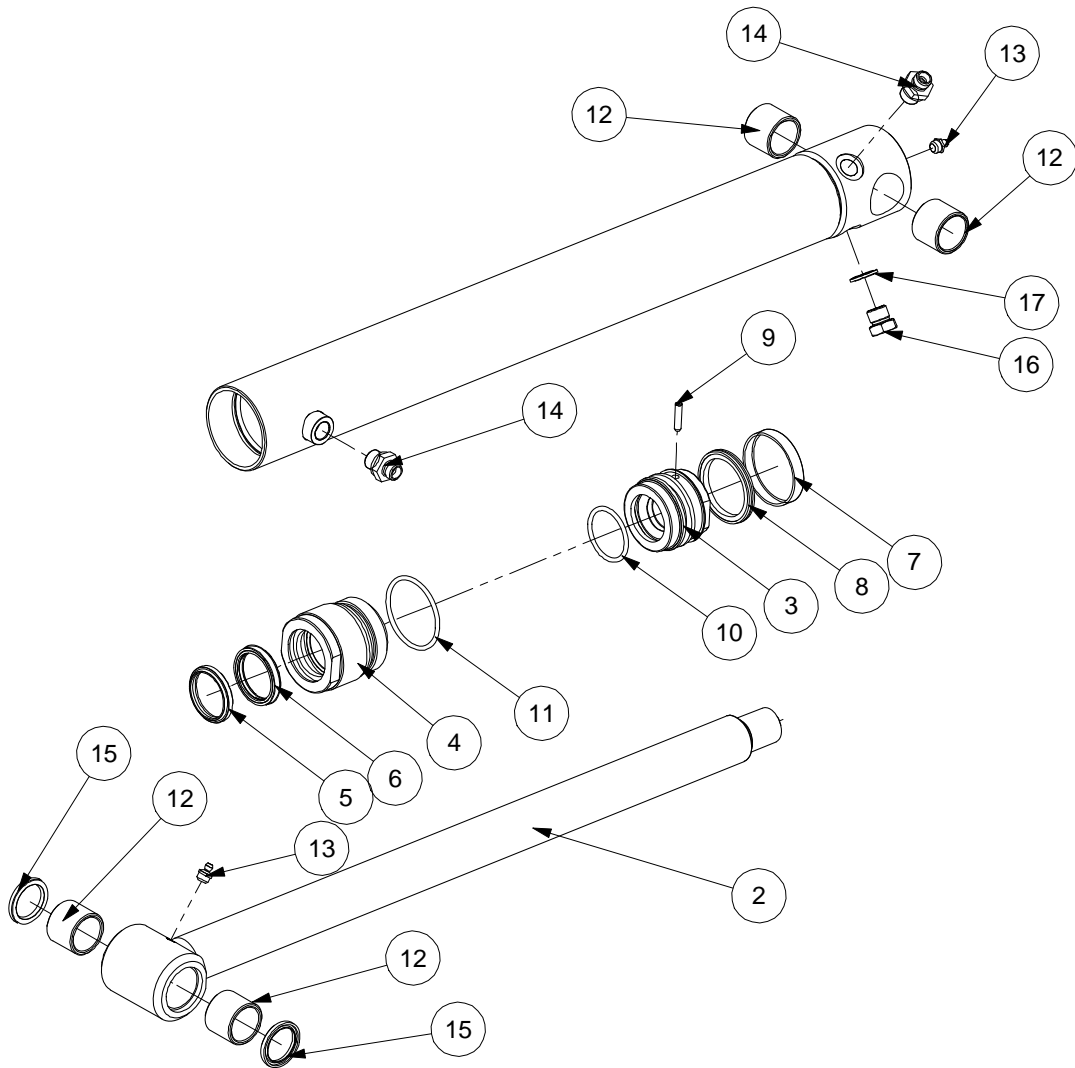

REF.	QTY.	PART No.	DESCRIPTION
		<b>21106.01</b>	<b>ANGLING RAM ASSEMBLY</b>
1	1	21106.02	BARREL
2	1	21106.03	PISTON ROD
3	1	43317.31	PISTON
4	1	43317.32	GLAND HOUSING
5	1	8629208	SCRAPER RING
6	1	8629225	GLAND SEAL
7	1	8629157	GUIDE RING
8	1	8629156	PISTON SEAL
9	1	42775.01	DOWEL
10	1	8600301	O RING
11	1	8600306	O RING
12	4	08.297.04	BUSH
13	2	0901121	GREASE NIPPLE
14	2	8581369	ADAPTOR
15	2	8629218	LIP SEAL
16	1	05.433.01	HEX PLUG
17	1	8650103	BONDED SEAL
		<b>43317.01</b>	<b>SEAL KIT</b>

# LIFT RAM ASSEMBLY

**MODULE:**  
21136.02

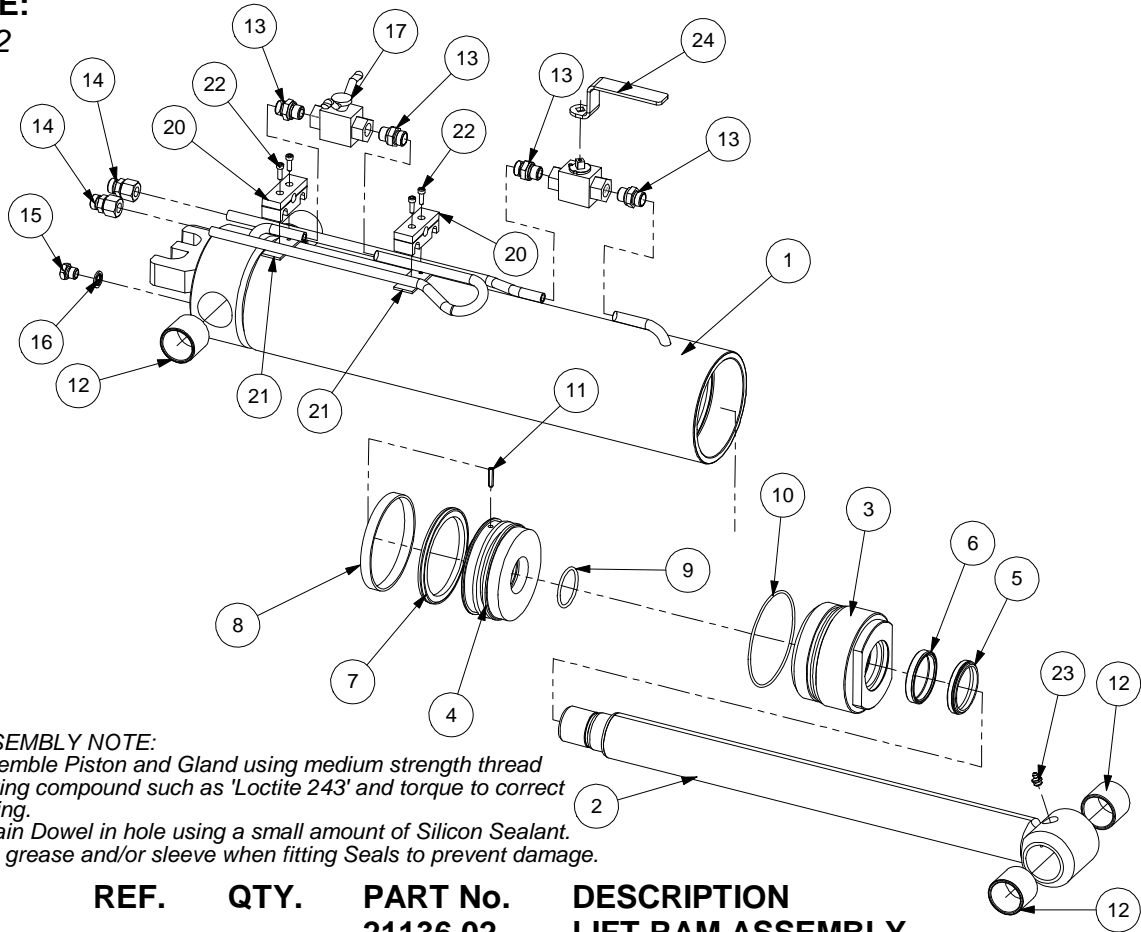

**ASSEMBLY NOTE:**  
 Assemble Piston and Gland using medium strength thread locking compound such as 'Loctite 243' and torque to correct setting.  
 Retain Dowel in hole using a small amount of Silicon Sealant.  
 Use grease and/or sleeve when fitting Seals to prevent damage.

REF.	QTY.	PART No.	DESCRIPTION
		<b>21136.02</b>	<b>LIFT RAM ASSEMBLY</b>
1	1	21136.35	RAM BARREL
2	1	21136.33	PISTON ROD
3	1	21136.32	GLAND HOUSING
4	1	21136.31	PISTON
5	1	8629233	ROD WIPER
6	1	8629234	ROD SEAL
7	1	8629235	PISTON SEAL
8	1	8629236	GUIDE RING
9	1	8600302	O RING
10	1	8700748	O RING
11	1	42775.01	DOWEL
12	4	08.297.02	BUSH
13	4	8581370	ADAPTOR
14	2	8581349	ADAPTOR
15	1	520378	ADAPTOR PLUG
16	1	8650102	BONDED SEAL
17	2	08.200.01	VALVE - ISOLATING
18	1	21139.01	PIPE - LIFT GLAND
19	1	21139.02	BASE PIPE
20	2	21140.01	CLAMP
21	2	21140.02	CLAMP PLATE BASE
22	4	9343032	CAPSCREW
23	1	0901121	GREASE NIPPLE
24	1	21193.01	TAP HANDLE
		<b>21136.01</b>	<b>SEAL KIT</b>



# REACH RAM ASSEMBLY

**MODULE:**  
21094.01

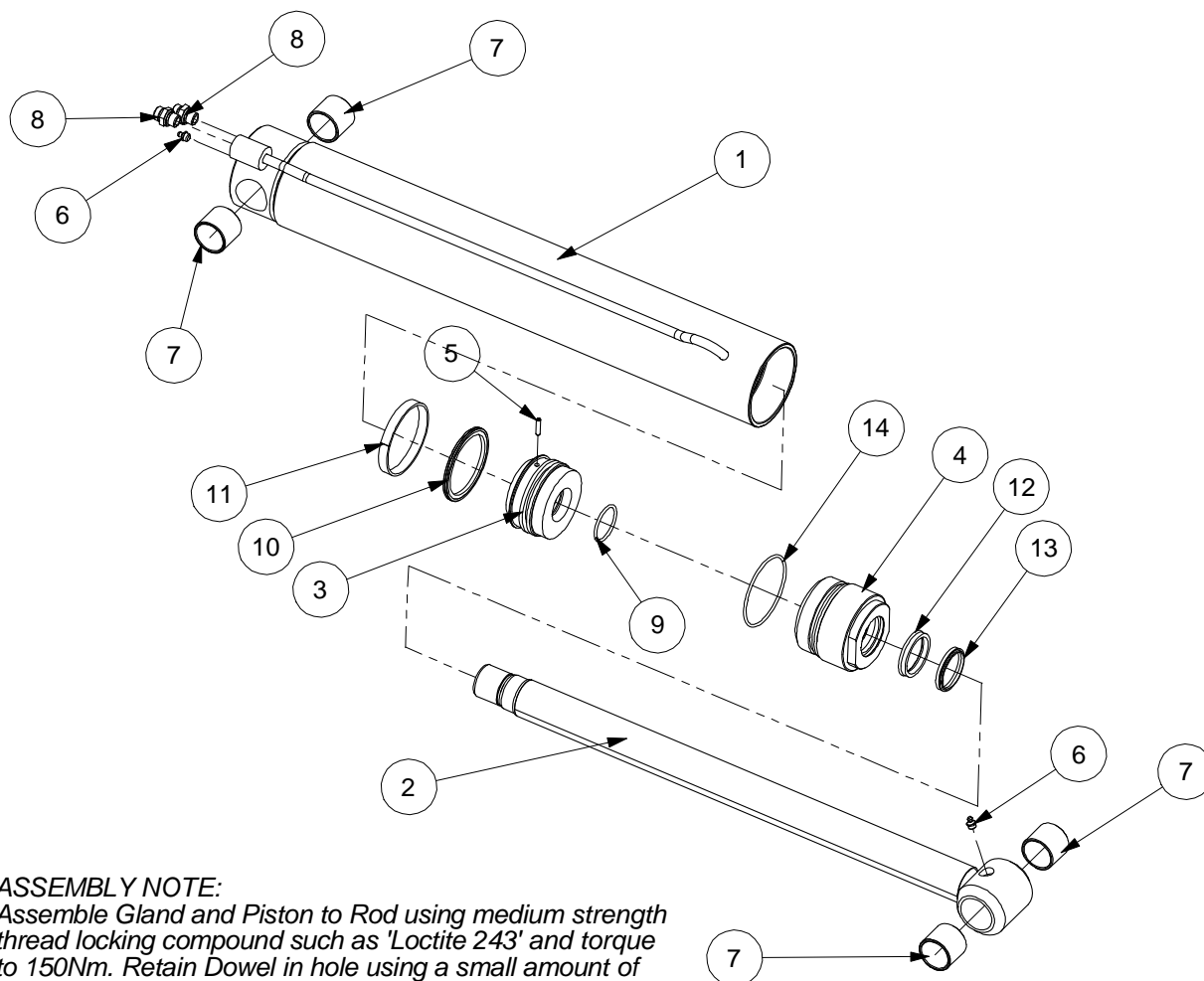

**ASSEMBLY NOTE:**  
 Assemble Gland and Piston to Rod using medium strength thread locking compound such as 'Loctite 243' and torque to 150Nm. Retain Dowel in hole using a small amount of Silicon Sealant.  
 Use grease and/or sleeve when fitting Seals to prevent damage.

REF.	QTY.	PART No.	DESCRIPTION
		<b>21094.01</b>	<b>REACH RAM ASSEMBLY</b>
1	1	21095.01	BARREL
2	1	21096.01	PISTON ROD
3	1	42655.31	PISTON
4	1	42655.48	GLAND HOUSING
5	1	42775.01	DOWEL
6	2	0901121	GREASE NIPPLE
7	4	08.297.02	BUSH
8	2	8581370	ADAPTOR
9	1	8600302	O RING
10	1	8629182	PISTON SEAL
11	1	8629183	BEARING RING
12	1	8629184	SEAL
13	1	8629227	GLAND SEAL
14	1	8600317	O RING
		<b>21094.02</b>	<b>SEAL KIT</b>

# SLEW RAM ASSEMBLY

**MODULE:**

21109.01

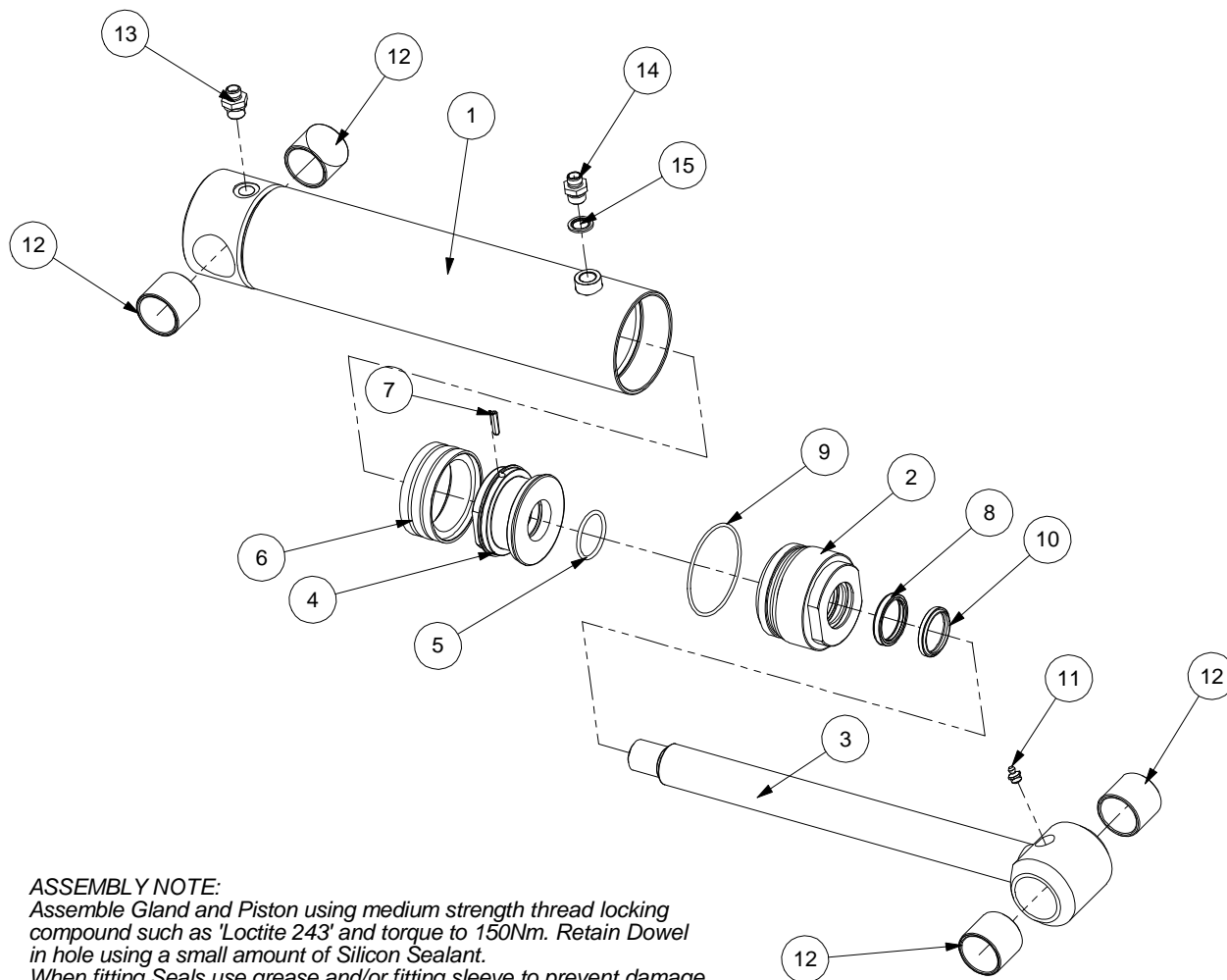

**ASSEMBLY NOTE:**

Assemble Gland and Piston using medium strength thread locking compound such as 'Loctite 243' and torque to 150Nm. Retain Dowel in hole using a small amount of Silicon Sealant.  
When fitting Seals use grease and/or fitting sleeve to prevent damage.

REF.	QTY.	PART No.	DESCRIPTION
		<b>21109.01</b>	<b>SLEW RAM ASSEMBLY</b>
1	1	21110.01	BARREL
2	1	43315.32	GLAND HOUSING
3	1	43316.33	PISTON ROD
4	1	43315.31	PISTON
5	1	8600301	O RING
6	1	8638742	PISTON SEAL
7	1	42775.01	DOWEL
8	1	8629225	GLAND SEAL
9	1	8600742	O RING
10	1	8629208	SCRAPER RING
11	1	0901121	GREASE NIPPLE
12	4	08.297.02	BUSH
13	1	8581369	ADAPTOR
14	1	8124105	ADAPTOR RESTRICTOR
15	1	8650103	BONDED SEAL
		<b>43315.01</b>	<b>SEAL KIT</b>

**TELE RAM ASSEMBLY**

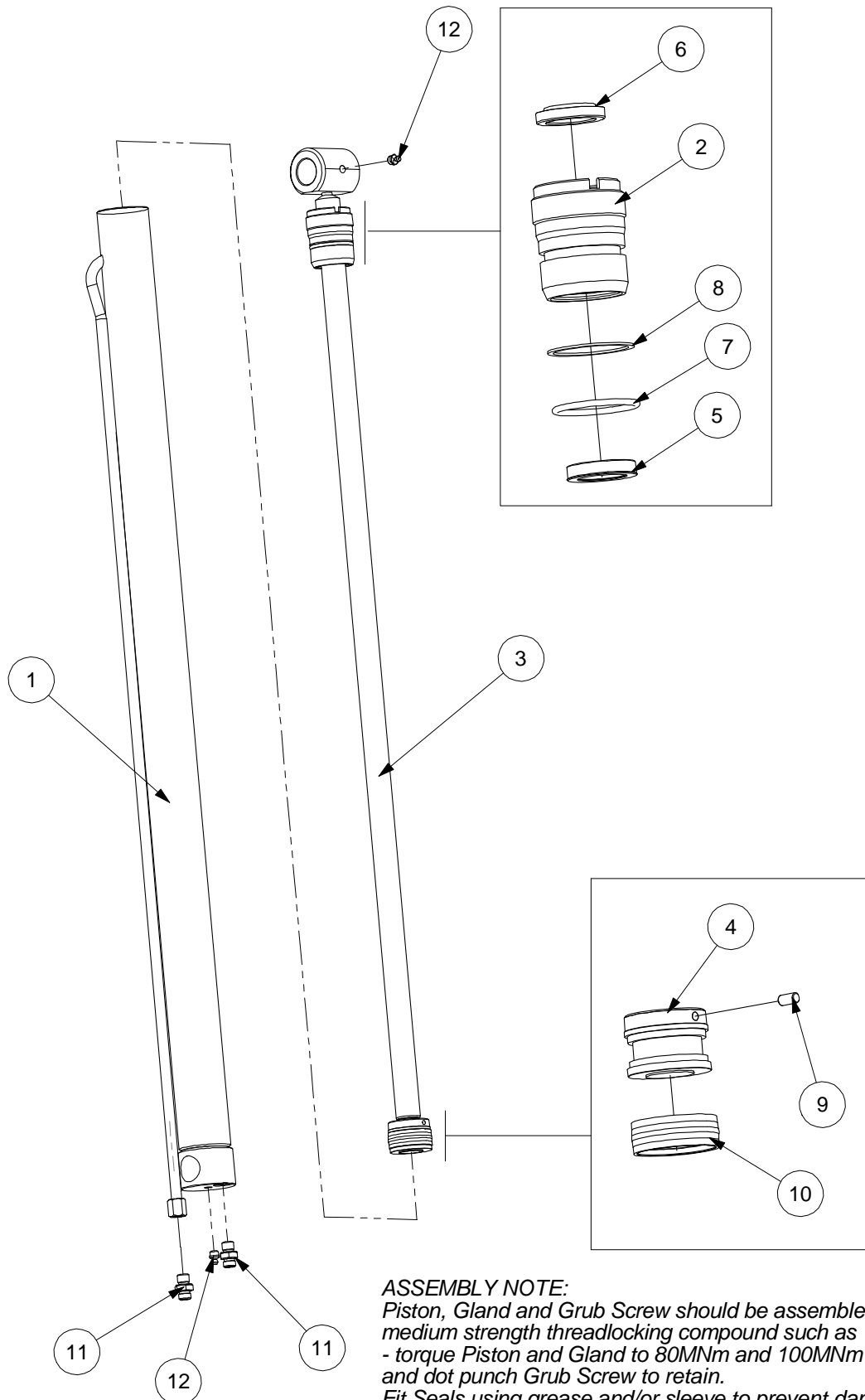
**MODULE:**  
21080.01



**ASSEMBLY NOTE:**  
Piston, Gland and Grub Screw should be assembled using a medium strength threadlocking compound such as 'Loctite 243' - torque Piston and Gland to 80MNm and 100MNm respectively and dot punch Grub Screw to retain.  
Fit Seals using grease and/or sleeve to prevent damage.

**TELE RAM ASSEMBLY**

REF.	QTY.	PART NO.	DESCRIPTION
		<b>21080.01</b>	<b>TELE RAM ASSEMBLY</b>
1	1	21081.01	BARREL
2	1	7135291	GLAND HOUSING
3	1	21082.01	ROD
4	1	7135008	PISTON
5	1	8629148	GLAND SEAL
6	1	8629149	SCRAPER RING
7	1	8600302	O RING
8	1	8609302	AE RING
9	1	9363023	GRUB SCREW
10	1	8638788	PISTON SEAL
11	2	8581374	ADAPTOR
12	2	0901121	GREASE NIPPLE
		<b>8699188</b>	<b>SEAL KIT</b>

# PROPORTIONAL CONTROLS - v.3

## MODULES:

43022.20 – Proportional

43022.21 – Proportional EDS

### OPERATOR CONTROLS/FUNCTIONS

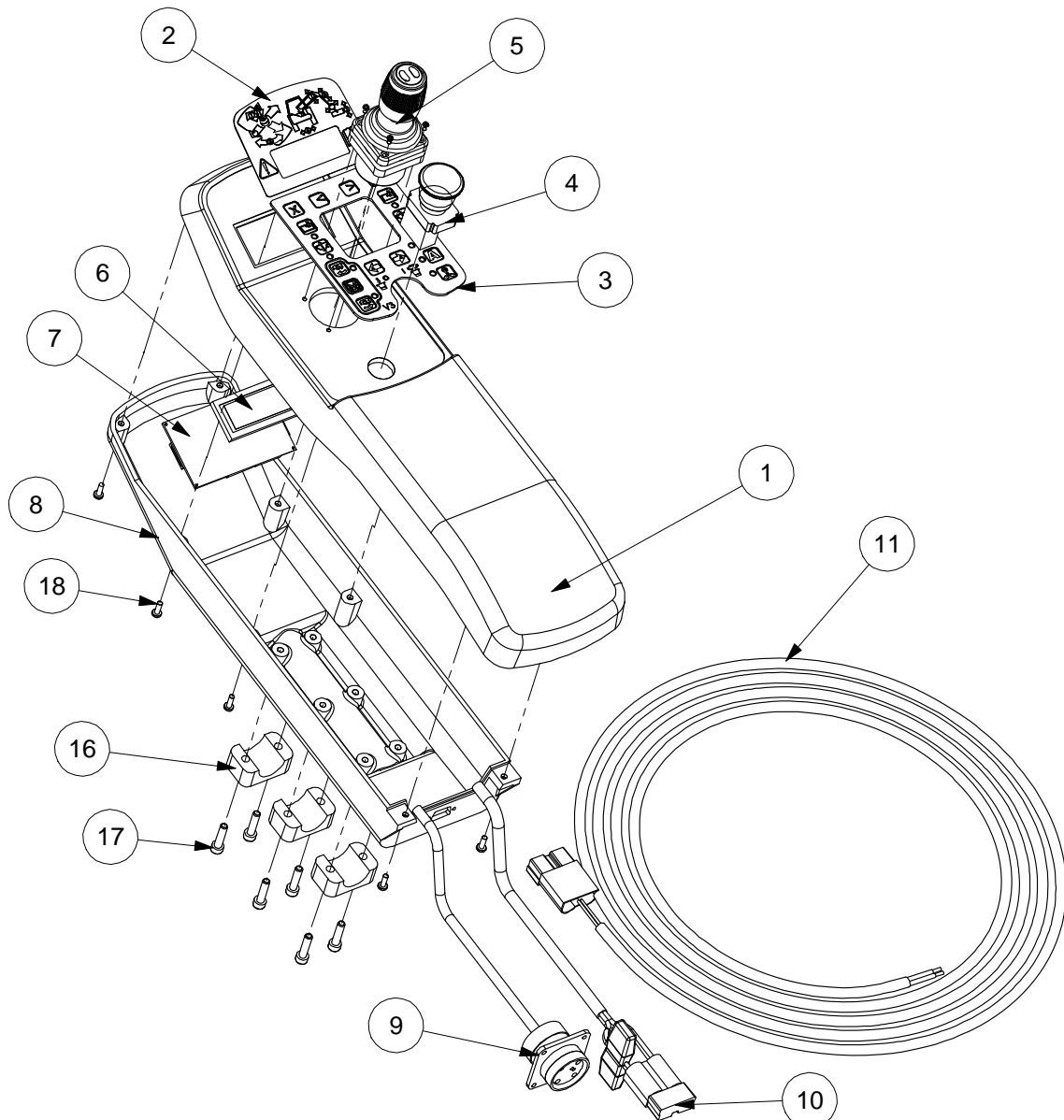
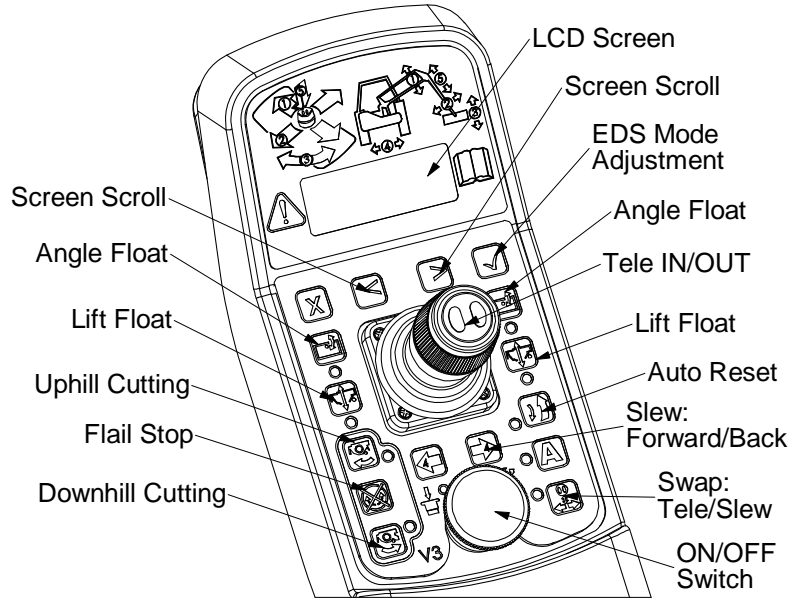

**PROPORTIONAL CONTROLS - v.3**

REF.	QTY.	PART No.	DESCRIPTION
		<b>43022.20</b>	<b>v.3 PROPORTIONAL ARMREST CONTROLS</b>
		<b>43022.21</b>	<b>v.3 PROPORTIONAL ARMREST CONTROLS - EDS</b>
1	1	43022.324	ARMREST LID - GREY
2	1	43022.50	FRONT DECAL
3	1	43022.51	JOYSTICK KEYPAD
4	1	41786.33	SWITCH - EMERGENCY STOP
5	1	45710.96	JOYSTICK - <i>inc. fixing screws</i>
6	1	43022.52	LCD SCREEN
7	1	43022.53	CIRCUIT BOARD
8	1	43022.321	ARMREST BASE - YELLOW
9	1	43022.46	CONNECTOR & LEAD
10	1	43022.47	CONNECTOR & POWER LEAD (2 FUSES)
11	2	8402237	LOOM - POWER SUPPLY
12	2	8402149	GLAND
13	1	43022.39	CONNECTOR 9 WAY
14	1	8600119	O RING - <i>not illustrated</i>
15	1	8402239	PUSH ON COVER - <i>not illustrated</i>
16	3	30.209.71	PIPE CLAMP
17	6	9343053	CAPSCREW
18	8	9300132	PANHEAD SCREW

# AUXILIARY CONTROL BOX

MODULE:  
21164.03

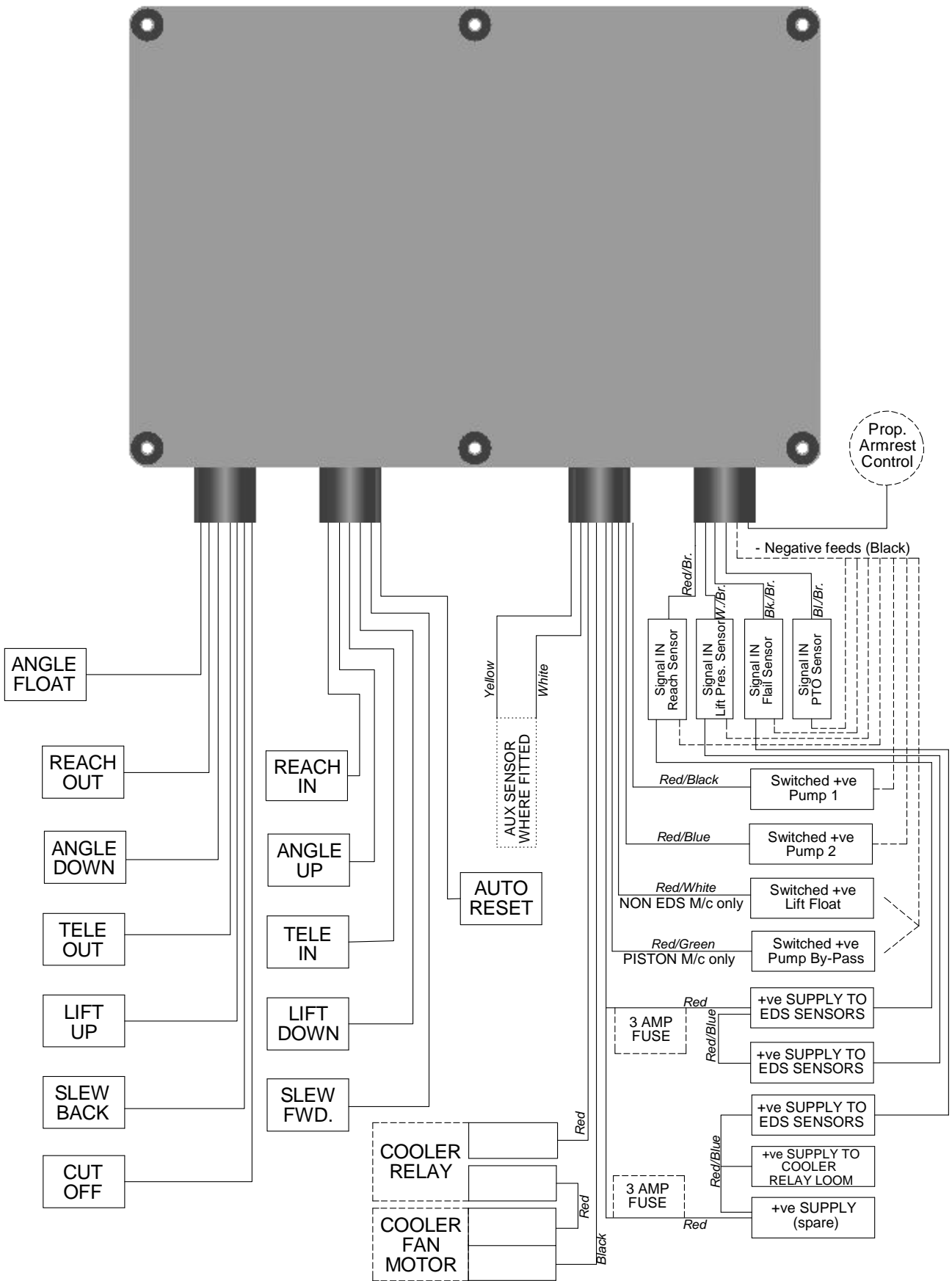

## CONTROL BOX/VALVE MOUNTING

### MODULES:

7680510 - Standard Arm L/H (4 service)

7680511 - Standard Arm R/H (4 service)

7680512 - Tele/Midcut Arm L/H (5 service)

7680513 - Tele/Midcut Arm R/H (5 service)

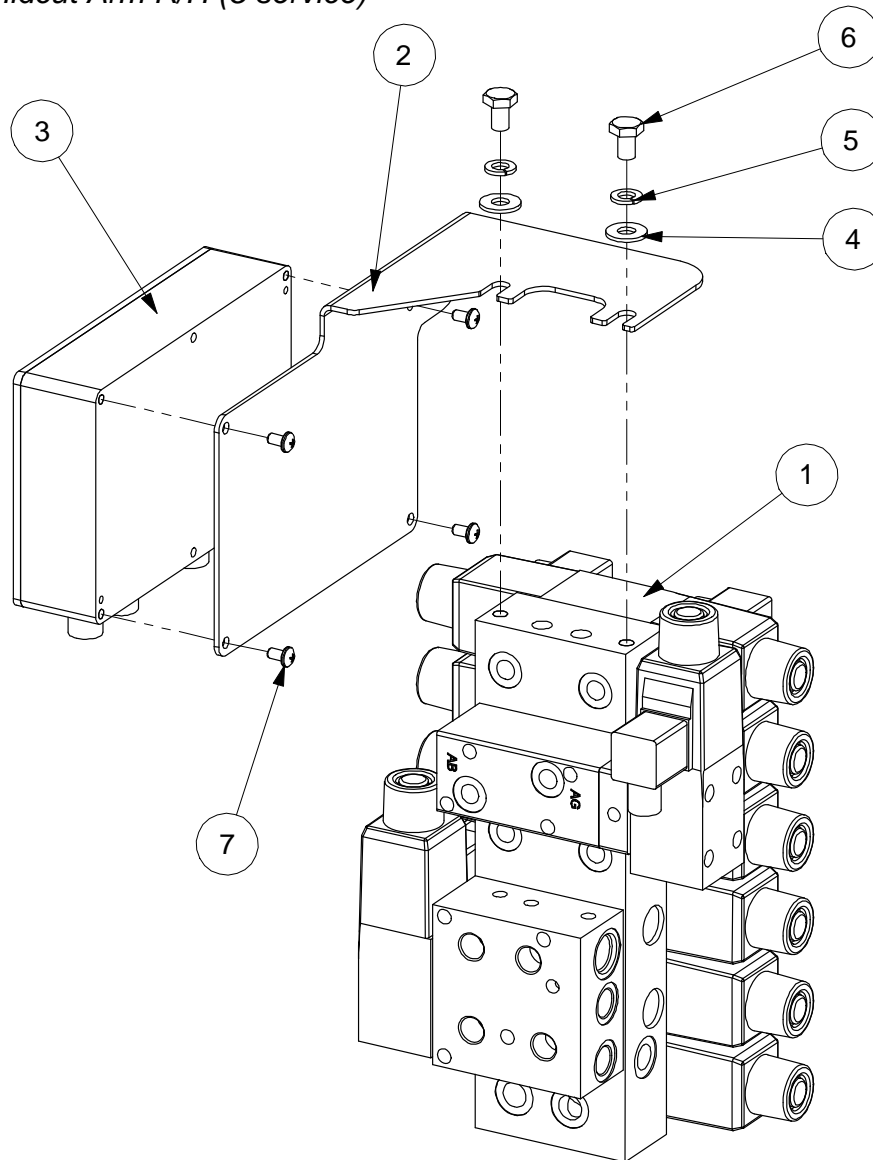
*Illustrated in Tele/Midcut Left-Hand build*

REF.	QTY.	PART No.	DESCRIPTION
		<b>7680512</b>	<b>AUXILIARY CONTROL BOX/VALVE ASSEMBLY</b>
1	1	8130663	SOLENOID MANIFOLD ASSEMBLY - 5 SERVICE
	1	8130664	SOLENOID MANIFOLD ASSEMBLY - 4 SERVICE
2	1	21170.01	CONTROLLER MOUNT BRACKET - L/H BUILD
	1	21170.03	CONTROLLER MOUNT BRACKET - R/H BUILD
3	1	21164.03	CONTROLLER V3 ASSEMBLY
4	2	9100105	FLAT WASHER
5	2	9100205	SPRING WASHER
6	2	9313035	SETSCREW
7	4	9300164	TAPTITE



**EDS SENSOR KITS**

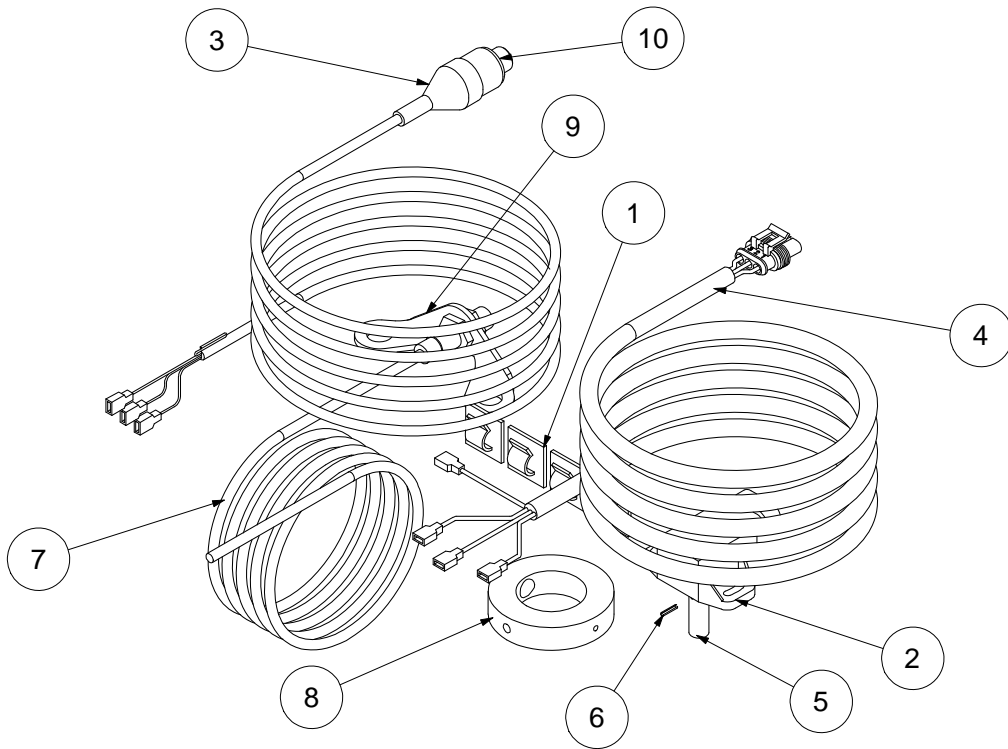

**7556703 - EDS Sensor Kit**

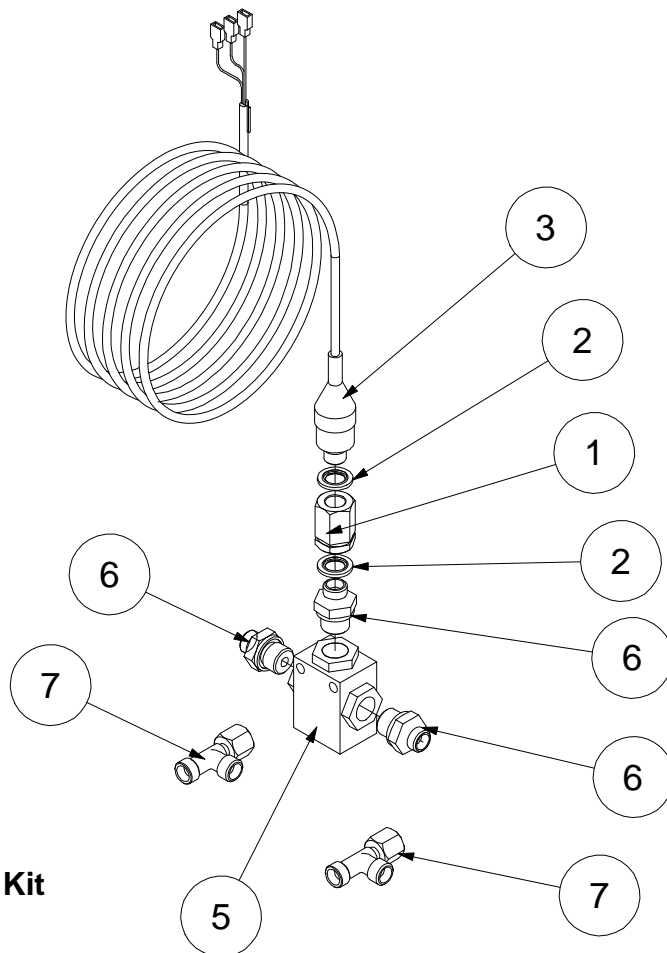

**7556705 - Power Monitor Kit**

**EDS SENSOR KITS**

REF.	QTY.	PART No.	DESCRIPTION
		<b>7556703</b>	<b>EDS SENSOR KIT</b>
1	4	43357.01	CLIP (SELF ADHESIVE PAD)
2	1	8402235	REACH SENSOR
3	1	8402253	PRESSURE SENSOR c/w LOOM
4	1	21163.01	REACH SENSOR LOOM
5	1	45425.07	SENSOR EXTENSION
6	1	0430110	SPRING DOWEL
7	1	8402251	PTO SENSOR
8	1	8402252	PTO MAGNETIC RING
9	1	21170.04	PTO SENSOR BRACKET
10	1	8650102	BONDED SEAL
		<b>7556705</b>	<b>POWER MONITOR KIT</b>
1	1	8581448	ADAPTOR
2	2	8650102	BONDED SEAL
3	1	8402254	PRESSURE SENSOR - 0 TO 400 BAR
4	2	42718.09	HOSE - M14 FS/F90 450mm
5	1	09.820.01	SHUTTLE VALVE
6	3	8581369	ADAPTOR
7	2	8581359	ADAPTOR TEE

# CONTROLS MOUNTING KIT

**MODULE:**  
7313275

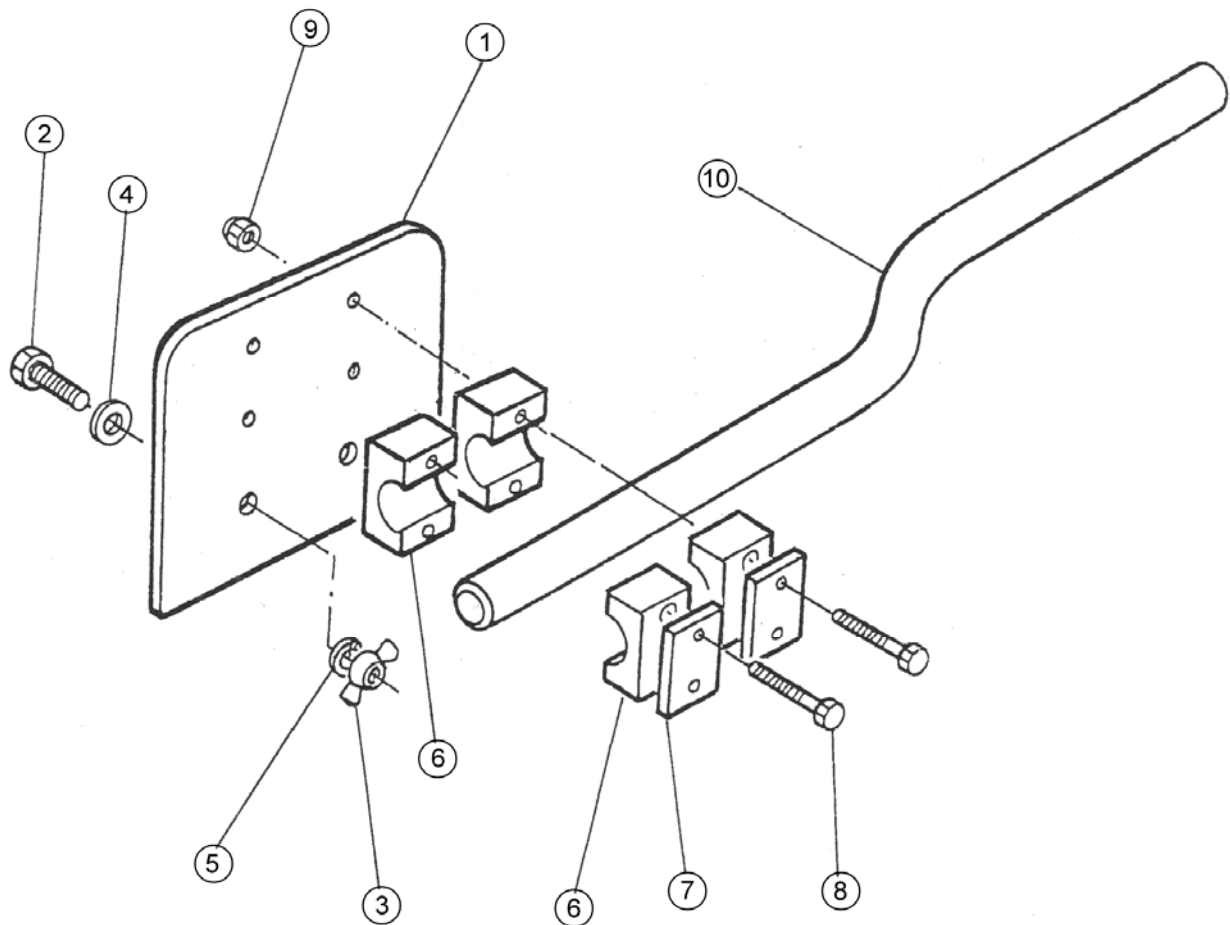

REF.	QTY.	PART NO.	DESCRIPTION
		<b>7313275</b>	<b>CONTROL MOUNTING KIT</b>
1	1	08.317.01	CONTROL MOUNTING BRACKET
2	2	9313054	SETSCREW M8 x 25
3	2	9193004	WINGNUT M8
4	2	9100104	PLAIN WASHER DIA. 8
5	2	9100204	SPRING WASHER DIA. 8
6	6	30.209.71	CLAMP
7	3	30.209.33	COVER PLATE
8	6	30.068.88	BOLT M6 x 45
9	4	9163003	SELF LOCKING NUT M6
10	1	42312.01	MOUNTING BAR

# CAB GUARD KIT

**MODULE:**  
7313324

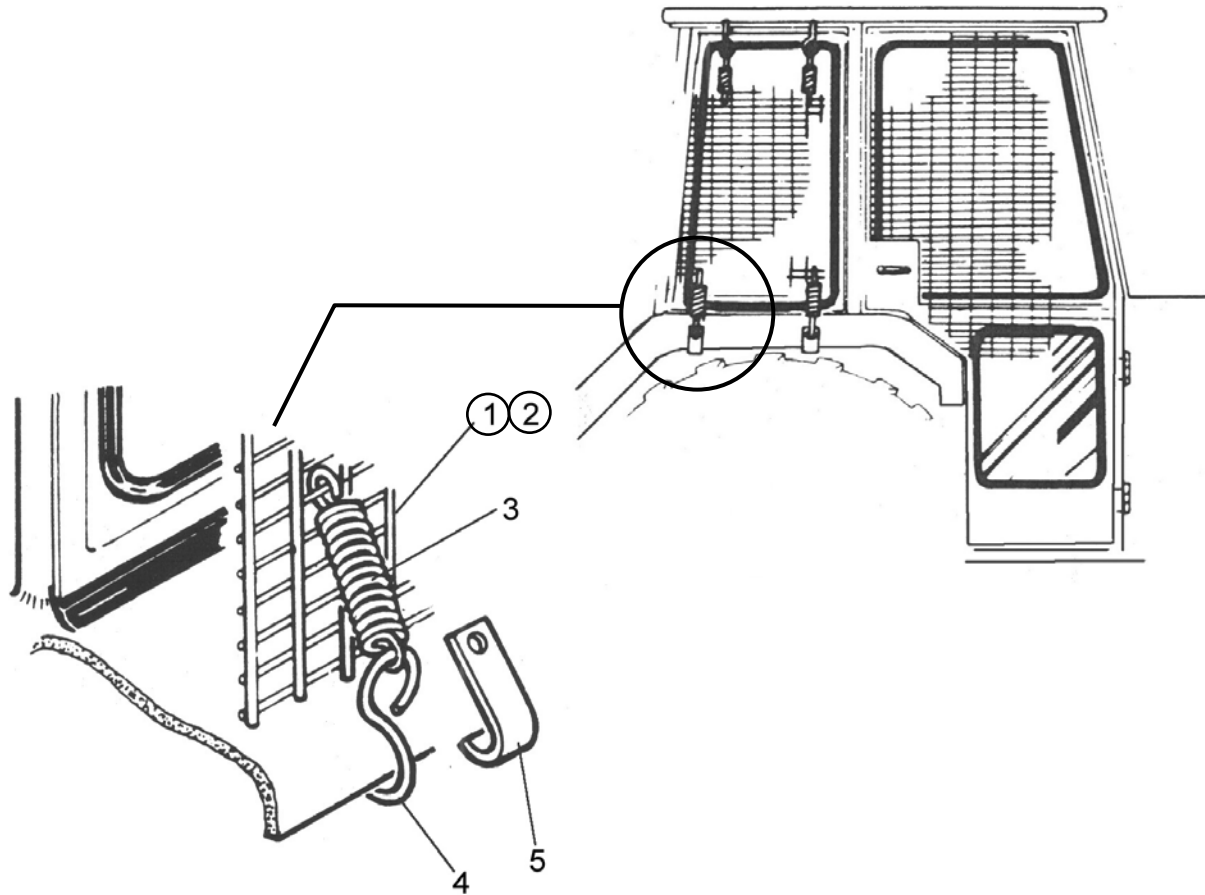

REF.	QTY.	PART No.	DESCRIPTION
		<b>7313324</b>	<b>CAB GUARD &amp; MOUNTING KIT</b>
1	1	7313049	GUARD PANEL - LARGE
2	1	7313050	GUARD PANEL - SMALL
3	12	6001064	SPRING
4	6	6001065	HOOK
5	6	7313051	HOOK

# REAR COVERS ASSEMBLY

## MODULES:

7666514 – L/H build

7666515 – R/H build

*Illustrated in Left-Hand build*

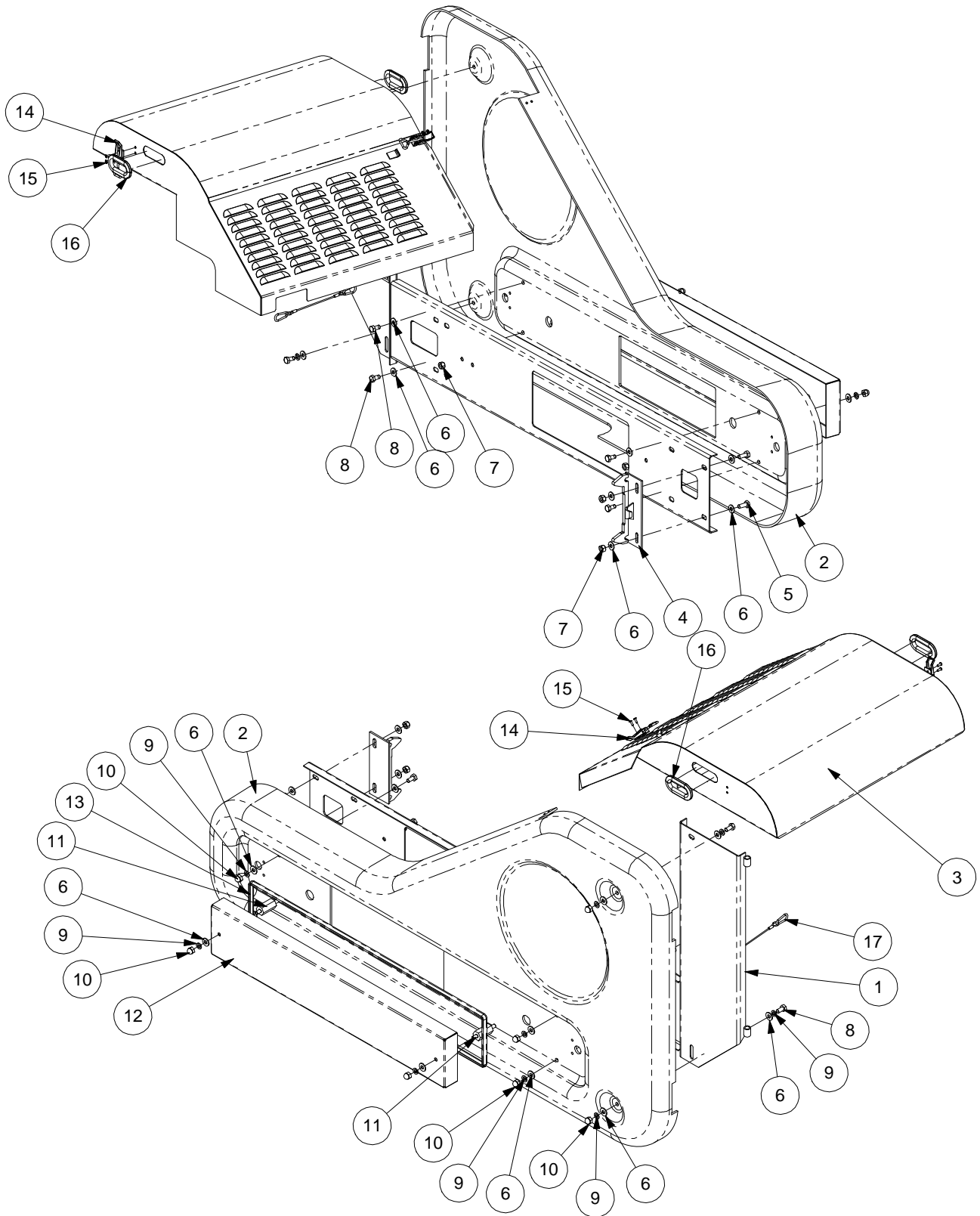



## REAR COVERS ASSEMBLY

REF.	QTY.	PART No.	DESCRIPTION
		<b>7666514</b>	<b>REAR COVERS ASSEMBLY - L/H</b>
		<b>7666515</b>	<b>REAR COVERS ASSEMBLY - R/H</b>
1	1	21065.01	COVER MOUNTING - L/H
		21065.02	COVER MOUNTING - R/H ( <i>not illustrated</i> )
2	1	21154.03	REAR COVER - L/H
		21154.04	REAR COVER - R/H ( <i>not illustrated</i> )
3	1	21069.01	VALVE COVER - L/H
		21069.02	VALVE COVER - R/H ( <i>not illustrated</i> )
4	1	43504.01	BRACKET
5	2	9313055	SETSCREW
6	18	9100105	FLAT WASHER
7	4	9143005	SELF-LOCKING NUT
8	6	9313045	SETSCREW
9	10	9100205	SPRING WASHER
10	8	9100025	DOME NUT
11	2	46041.01	STAND OFF
12	1	46046.02	COOLER FILTER BASKET
13	1	43468.09	EDGING
14	2	43449.02	OVERCENTRE FASTENER
15	4	1069088	POP RIVET
16	2	43468.10	EDGING
17	1	43429.01	RESTRAINT CABLE



# REAR LIGHTING KIT

MODULE:  
45900.02

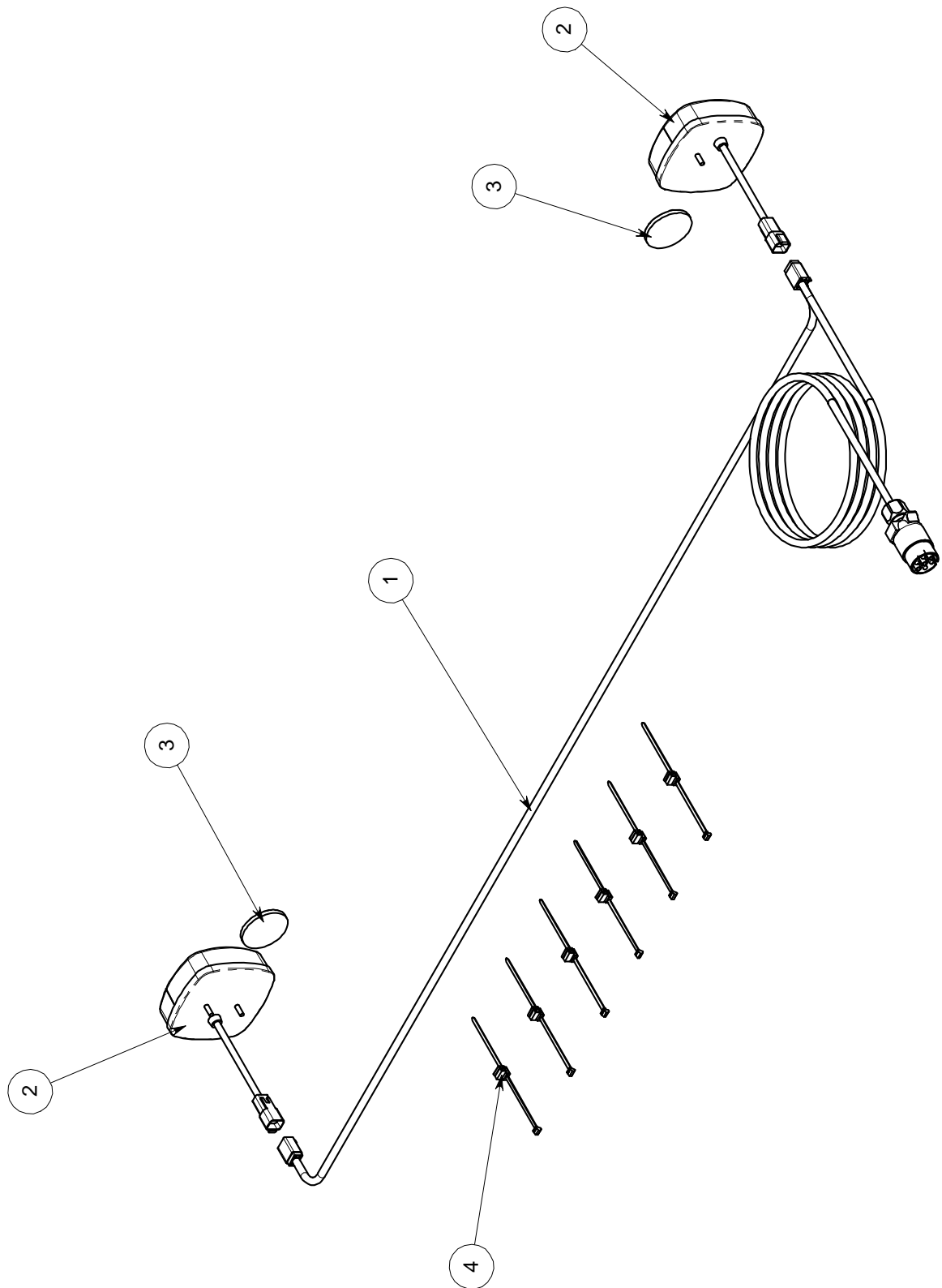

**REAR LIGHTING KIT**

<b>REF.</b>	<b>QTY.</b>	<b>PART NO.</b>	<b>DESCRIPTION</b>
		<b>45900.02</b>	<b>LIGHTING KIT ASSEMBLY</b>
1	1	45656.02	LIGHTING LOOM - LONG
2	2	45642.02	COMBINATION LAMP ASSY
3	2	45671.01	REFLECTOR-SELF ADHESIVE
4	6	21150.01	PUSH ON CABLE TIE



**MACHINE DECALS**

**MODULE:**  
7680508

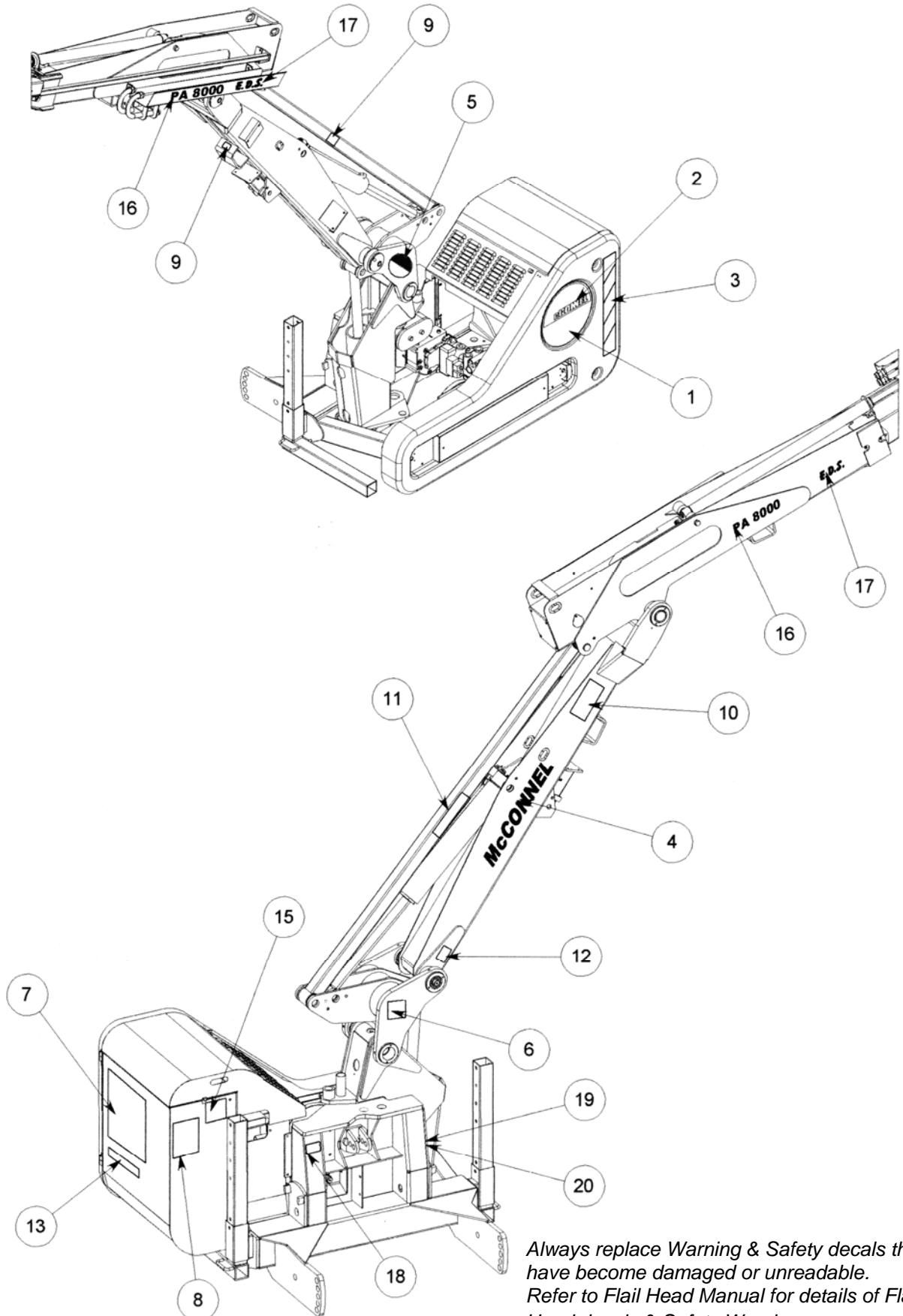

*Always replace Warning & Safety decals that have become damaged or unreadable. Refer to Flail Head Manual for details of Flail Head decals & Safety Warnings.*

**MACHINE DECALS**

REF.	QTY.	PART No.	DESCRIPTION
		<b>7680508</b>	<b>DECAL KIT</b>
1	1	1290524	LOGO ROUNDEL - YELLOW
2	1	1290525	McCONNEL - SMALL YELLOW
3	1	1290528	REAR MARKER
4	2	1290255	McCONNEL BLACK
5	1	1290296	LOGO
6	1	7105130	READ INSTRUCTION BOOK
7	1	1290391	GENERAL WARNING
8	1	00756494	PTO SHAFT
9	5	02962764	PINCH POINT
10	1	1290403	BREAKAWAY RETURN
11	1	1290406	TRANSPORT
12	1	8402138	SLEW WARNING
13	1	1290482	PISTON SYSTEM
14	1	1290005	GREASE SOCKET
15	1	1290023	FILTER
16	2	1290570	PA 8000
17	2	1290518	EDS
18	1	1290461	1000 RPM
19	1	1335246	SERIAL No. PLATE
20	4	7103230	POP RIVET

## DEBRIS BLOWER MOUNTING KIT

### Modules:

7456770 – L/H Build

7456771 – R/H Build

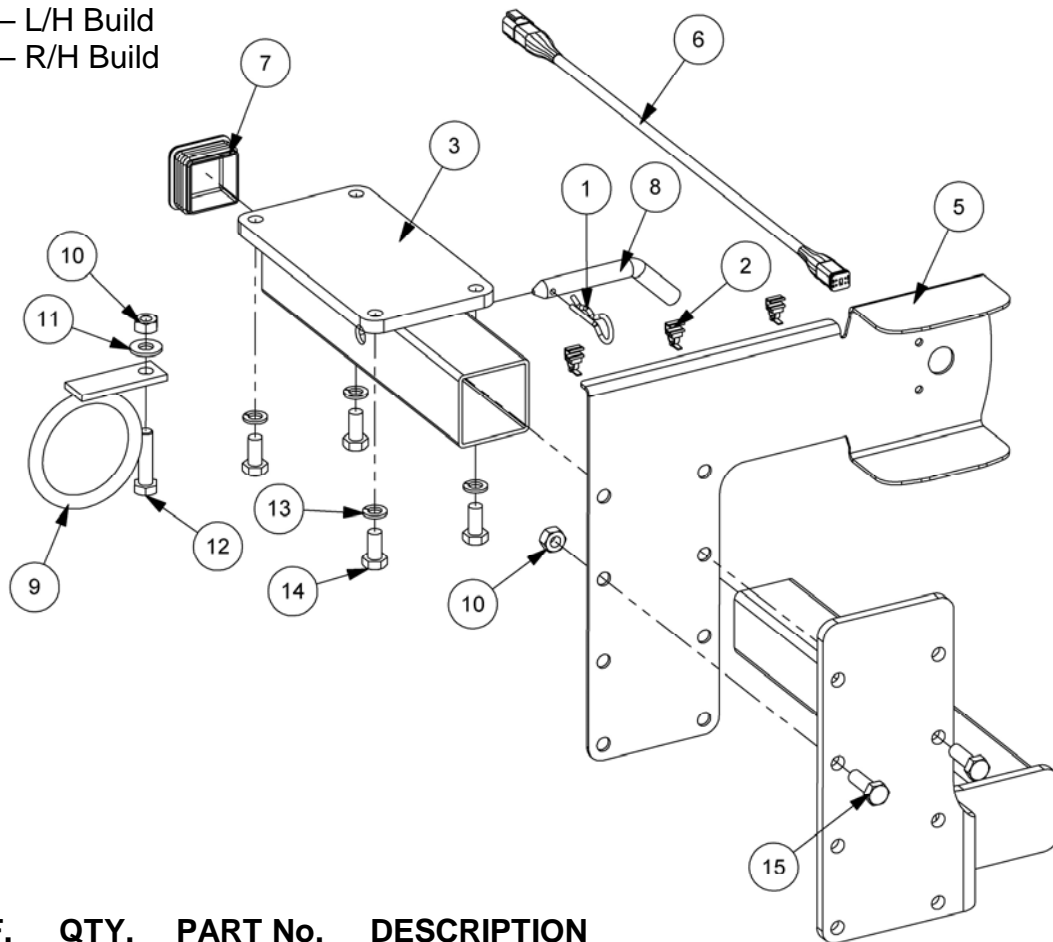
*Illustrated in Left Hand Build*

REF.	QTY.	PART No.	DESCRIPTION
		<b>7456770</b>	<b>DEBRIS BLOWER MOUNTING KIT - L/H Machines</b>
		<b>7456771</b>	<b>DEBRIS BLOWER MOUNTING KIT - R/H Machines</b>
1	1	0431105	SPRING COTTER
2	3	21150.01	PUSH ON CABLE TIE
3	1	43492.01	BLOWER BRACKET
4	1	43492.05	BLOWER BRACKET - L/H Build
	1	43492.06	BLOWER BRACKET - R/H Build
5	1	43492.07	LIGHT BRACKET - L/H Build
	1	43492.08	LIGHT BRACKET - R/H Build
6	1	45657.01	LOOM EXTENTION
7	1	7191108	PLASTIC PLUG
8	1	7192023	LEG PIN
9	1	7319282	HOSE RING
10	3	9143006	SELF-LOCKING NUT
11	1	9100106	FLAT WASHER
12	1	9213106	BOLT
13	4	9100206	SPRING WASHER
14	4	9313056	SETSCREW
15	2	9313076	SETSCREW

*Suitable for the following machines:*

*PA45\*, PA47 Mk1\*, PA50 Mk1\*, PA52, PA59, PA550, PA650, PA8000*

*(\* with lightbars)*



McConnel Limited, Temeside Works, Ludlow, Shropshire SY8 1JL. England.  
Telephone: 01584 873131. Facsimile: 01584 876463. [www.mcconnel.com](http://www.mcconnel.com)