

Publication 136 A  
March 1989

Serial No.

Part No.  
71-91-852

# PA 91

## Operation & Spares manual



# IMPORTANT

## VERIFICATION OF WARRANTY REGISTRATION



### DEALER WARRANTY INFORMATION & REGISTRATION VERIFICATION

It is imperative that the selling dealer registers this machine with McConnel Limited within 7 days of delivery to the end user – failure to do so may affect the validity of the machine warranty.

To register machines go to the McConnel Limited web site at [www.mcconnel.com](http://www.mcconnel.com), log onto 'Dealer Inside' and select the 'Machine Registration button' which can be found in the Service Section of the site. Confirm to the customer that the machine has been registered in the section below.

Should you experience any problems registering a machine in this manner please contact the McConnel Service Department on 01584 875848.

#### Registration Verification

Dealer Name: .....
Dealer Address: .....
Customer Name: .....
Date of Warranty Registration: ...../...../..... Dealer Signature: .....

#### NOTE TO CUSTOMER / OWNER

*Please ensure that the above section above has been completed and signed by the selling dealer to verify that your machine has been registered with McConnel Limited.*

**IMPORTANT:** During the initial 'bedding in' period of a new machine it is the customer's responsibility to regularly inspect all nuts, bolts and hose connections for tightness and re-tighten if required. New hydraulic connections occasionally weep small amounts of oil as the seals and joints settle in – where this occurs it can be cured by re-tightening the connection – *refer to torque settings chart below*. The tasks stated above should be performed on an hourly basis during the first day of work and at least daily thereafter as part of the machines general maintenance procedure.

#### TORQUE SETTINGS FOR HYDRAULIC FITTINGS

HYDRAULIC HOSE ENDS		
BSP	Setting	Metric
1/4"	18 Nm	19 mm
3/8"	31 Nm	22 mm
1/2"	49 Nm	27 mm
5/8"	60 Nm	30 mm
3/4"	80 Nm	32 mm
1"	125 Nm	41 mm
1.1/4"	190 Nm	50 mm
1.1/2"	250 Nm	55 mm
2"	420 Nm	70 mm

PORT ADAPTORS WITH BONDED SEALS		
BSP	Setting	Metric
1/4"	34 Nm	19 mm
3/8"	47 Nm	22 mm
1/2"	102 Nm	27 mm
5/8"	122 Nm	30 mm
3/4"	149 Nm	32 mm
1"	203 Nm	41 mm
1.1/4"	305 Nm	50 mm
1.1/2"	305 Nm	55 mm
2"	400 Nm	70 mm

# WARRANTY POLICY

## WARRANTY REGISTRATION

All machines must be registered, by the selling dealer with McConnell Ltd, before delivery to the end user. On receipt of the goods it is the buyer's responsibility to check that the Verification of Warranty Registration in the Operator's Manual has been completed by the selling dealer.

### 1. LIMITED WARRANTIES

- 1.01. All machines supplied by McConnell Limited are warranted to be free from defects in material and workmanship from the date of sale to the original purchaser for a period of 12 months, unless a different period is specified.
- 1.02. All spare parts supplied by McConnell Limited are warranted to be free from defects in material and workmanship from the date of sale to the original purchaser for a period of 6 months.
- 1.03. The manufacturer will replace or repair for the purchaser any part or parts found, upon examination at its factory, to be defective under normal use and service due to defects in material or workmanship. Returned parts must be complete and unexamined.
- 1.04. This warranty does not apply to any part of the goods, which has been subjected to improper or abnormal use, negligence, alteration, modification, fitment of non-genuine parts, accident damage, or damage resulting from contact with overhead power lines, damage caused by foreign objects (e.g. stones, iron, material other than vegetation), failure due to lack of maintenance, use of incorrect oil or lubricants, contamination of the oil, or which has served its normal life. This warranty does not apply to any expendable items such as blades, flails, flap kits, skids, soil engaging parts, shields, guards, wear pads or pneumatic tyres.
- 1.05. Temporary repairs and consequential loss - i.e. oil, downtime and associated parts are specifically excluded from the warranty.
- 1.06. Warranty on hoses is limited to 12 months and does not include hoses which have suffered external damage. Only complete hoses may be returned under warranty, any which have been cut or repaired will be rejected.
- 1.07. Machines must be repaired immediately a problem arises. Continued use of the machine after a problem has occurred can result in further component failures, for which McConnell Ltd cannot be held liable, and may have safety implications.
- 1.08. Except as provided herein, no employee, agent, dealer or other person is authorised to give any warranties of any nature on behalf of McConnell Ltd.
- 1.09. For machine warranty periods in excess of 12 months the following additional exclusions shall apply:
  - 1) Hoses, external seals, exposed pipes and hydraulic tank breathers.
  - 2) Filters.
  - 3) Rubber mountings.
  - 4) External electric wiring.

**N.B. Warranty cover will be invalid if any non-genuine parts have been fitted or used. Use of non-genuine parts may seriously affect the machine's performance and safety. McConnell Ltd. cannot be held responsible for any failures or safety implications that arise due to the use of non-genuine parts.**

## **2. REMEDIES AND PROCEDURES**

- 2.01. The warranty is not effective unless the Selling Dealer registers the machine, via the McConnel web site and confirms the registration to the purchaser by completing the Verification of Warranty Registration in the operator's manual.
- 2.02. Any fault must be reported to an authorised McConnel dealer as soon as it occurs. Continued use of a machine, after a fault has occurred, can result in further component failure for which McConnel Ltd cannot be held liable.
- 2.03. Repairs should be undertaken within two days of the failure. Claims submitted for repairs undertaken more than 2 weeks after a failure has occurred, or 2 days after the parts were supplied will be rejected, unless the delay has been authorised by McConnel Ltd.
- 2.04. All claims must be submitted, by an authorised McConnel Service Dealer, within 30 days of the date of repair.
- 2.05. Following examination of the claim and parts the manufacture will pay, at their discretion, for any valid claim the cost of any parts and an appropriate labour allowance if applicable.
- 2.06. The submission of a claim is not a guarantee of payment.
- 2.07. Any decision reached by McConnel Ltd. is final.

## **3. LIMITATION OF LIABILITY**

- 3.01. The manufacturer disclaims any express (except as set forth herein) and implied warranties with respect to the goods including, but not limited to, merchantability and fitness for a particular purpose.
- 3.02. The manufacturer makes no warranty as to the design, capability, capacity or suitability for use of the goods.
- 3.03. Except as provided herein, the manufacturer shall have no liability or responsibility to the purchaser or any other person or entity with respect to any liability, loss, or damage caused or alleged to be caused directly or indirectly by the goods including, but not limited to, any indirect, special, consequential, or incidental damages resulting from the use or operation of the goods or any breach of this warranty. Notwithstanding the above limitations and warranties, the manufacturer's liability hereunder for damages incurred by the purchaser or others shall not exceed the price of the goods.
- 3.04. No action arising out of any claimed breach of this warranty or transactions under this warranty may be brought more than one (1) year after the cause of the action has occurred.

## **4. MISCELLANEOUS**

- 4.01. The manufacturer may waive compliance with any of the terms of this limited warranty, but no waiver of any terms shall be deemed to be a waiver of any other term.
- 4.02. If any provision of this limited warranty shall violate any applicable law and is held to be unenforceable, then the invalidity of such provision shall not invalidate any other provisions herein.
- 4.03. Applicable law may provide rights and benefits to the purchaser in addition to those provided herein.

# EC DECLARATION OF CONFORMITY

*Conforming to EEC Machinery Directive 98/37/EC\**

We,

**McCONNEL LIMITED,**

Temeside Works, Ludlow, Shropshire SY8 1JL.

*Declare under our sole responsibility that:*

The product (type) Tractor Mounted Flail Mower.....

.....

Product Code PA91.....

Serial No. & Date ..... Type .....

Manufactured by the above company/\* .....

.....

*(\* insert business name and full address if not stated above)*

Complies with the required provisions of the Machinery Directive 98/37/EC, \* previously Directive 89/392/EEC as amended by Directives 91/368/EEC, 93/44/EEC and 93/68/EEC.

The machinery directive is supported by;

- BS EN ISO 12100:2003 Safety of Machinery. This standard is made up of two parts; Part 1 Terminology, methodology, Part 2 Technical Specifications.
- BS EN 1050 Safety of machinery - Principles of risk assessment.
- and other national standards associated with its design and construction as listed in the Technical File.

The Machinery Directive is fully implemented into UK law by means of the Supply of Machinery (Safety) Regulations 1992 (SI 1992/3073) as amended by The Supply of Machinery (Safety) (Amendment) Regulations 1994 (SI 1994/2063).

Signed John Frank.....

*on behalf of McCONNEL LIMITED*

*Responsible Person*

*Status:* Chief Design Engineer

*Date:* May 2005

# EC DECLARATION OF CONFORMITY

*Conforming to EEC Machinery Directive 98/37/EC\**

We,

**McCONNEL LIMITED,**

Temeside Works, Ludlow, Shropshire SY8 1JL.

*Declare under our sole responsibility that:*

The product (type) Hydraulic Arm Mounted Flailhead.....

.....

Product Code BD12, BD16, F110, F112, F115, F012, F016.....

Serial No. & Date ..... Type .....

Manufactured by the above company/\* .....

.....

*(\* insert business name and full address if not stated above)*

Complies with the required provisions of the Machinery Directive 98/37/EC, \* previously Directive 89/392/EEC as amended by Directives 91/368/EEC, 93/44/EEC and 93/68/EEC.

The machinery directive is supported by;

- BS EN ISO 12100:2003 Safety of Machinery. This standard is made up of two parts; Part 1 Terminology, methodology, Part 2 Technical Specifications.
- BS EN 1050 Safety of machinery - Principles of risk assessment.
- and other national standards associated with its design and construction as listed in the Technical File.

The Machinery Directive is fully implemented into UK law by means of the Supply of Machinery (Safety) Regulations 1992 (SI 1992/3073) as amended by The Supply of Machinery (Safety) (Amendment) Regulations 1994 (SI 1994/2063).

Signed John Frank.....

*on behalf of McCONNEL LIMITED*

*Responsible Person*

*Status:* Chief Design Engineer

*Date:* May 2005





*For Safety and Performance ...*

**ALWAYS READ THIS BOOK FIRST**

## **McCONEl LIMITED**

**Temeside Works  
Ludlow  
Shropshire  
England**

**Telephone: 01584 873131  
[www.mccommel.com](http://www.mccommel.com)**

### **NOISE STATEMENT**

The equivalent daily personal noise exposure from this machine measured at the operators' ear is within the range 78 – 85 dB, these figures apply to a normal distribution of use where the noise fluctuates between zero and maximum. The figures assume that the machine is fitted to a tractor with a 'quiet' cab with the windows closed in a generally open environment. We recommend that the windows are kept closed. With the cab rear window open the equivalent daily personal noise exposure will increase to a figure within the range 82 – 88 dB. At equivalent daily noise exposure levels of between 85 – 90 dB ear protection is recommended – it should be used if any window is left open.



## GENERAL INFORMATION

---

Always read this manual before fitting or operating the machine – whenever any doubt exists contact your dealer or the McConnel Service Department for advice and assistance.

### Use only McConnel Genuine Service Parts on McConnel Equipment and Machines

**DEFINITIONS** – *The following definitions apply throughout this manual:*

#### **WARNING**

An operating procedure, technique etc., which –  
can result in personal injury or loss of life if not observed carefully.

#### **CAUTION**

An operating procedure, technique etc., which –  
can result in damage to either machine or equipment if not observed carefully.

#### **NOTE**

An operating procedure, technique etc., which –  
is considered essential to emphasis.

#### **LEFT AND RIGHT HAND**

This term is applicable to the machine when attached to the tractor and is viewed from the rear – this also applies to tractor references.

## MACHINE & DEALER INFORMATION

*Record the Serial Number of your machine on this page and always quote this number when ordering parts. Whenever information concerning the machine is requested remember also to state the make and model of tractor to which the machine is fitted.*

Machine Serial Number:	Installation Date:
Machine Model details:	
Dealer Name:	
Dealer Address:	
Dealer Telephone No:	
Dealer Email Address:	

# INTRODUCTION

The power arm 91 is a hydraulically driven flail trimmer designed to mount onto the three point linkages of the great majority of tractors without having to use individual brackets or fittings for specific tractors.

All power for the operation of the rotor is provided by a high performance pump unit that is operated from the tractors P.T.O. shaft. The machine carries its own 20 galls ( 90 litres. 29 galls U.S.) oil reservoir which incorporates an oil strainer and a 10 micron return flow filter.

The power arm 91 can be supplied with either fully independent hydraulic system or a semi independent system where power for operating the arms is taken from the tractor external hydraulic supply.

The models also differ in that engagement of the rotor drive on the semi independent model is effected by operation of the tractors P.T.O. lever, while on the fully independent version a rotor control valve is operated by an extra lever on the control console which also allows selection of rotor rotation.

The machine has been designed in such a way that it can be mounted on the front or rear of the tractor and can cut on either the right or left side.

The flail head is despatched with an adjustable front mounted hood and rear mounted flap to minimise flying debris. All machines will be delivered with the flail to cut in an upward motion. In addition the operator is further protected by a mesh guard which is attached to the tractor's cab. In some cases it may be necessary for the operator or dealer to construct additional mesh guarding to ensure the safety of the operator see "Fitting cab guard".



# SAFETY INFORMATION

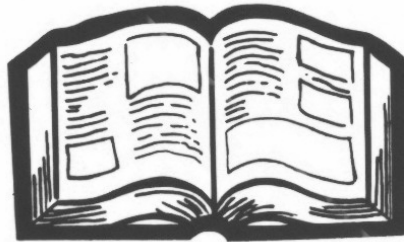

This machine has the potential to be extremely dangerous, in the wrong hands it can kill or maim. It is therefore imperative that both owner, and operator of this machine, read and understand the following section to ensure that they are fully aware of the dangers that do, or may exist, and their responsibilities surrounding the use and operation of the machine. The operator of this machine is responsible not only for their own safety but equally for the safety of others who may come into the close proximity of the machine, as the owner you are responsible for both.

When the machine is not in use the cutting head should be lowered to rest on the ground. In the event of a fault being detected with the machine's operation it should be stopped immediately and not used again until the fault has been corrected by a qualified technician.

## **POTENTIAL SIGNIFICANT DANGERS ASSOCIATED WITH THE USE OF THIS MACHINE:**

- ▲ *Being hit by debris thrown by rotating components.*
- ▲ *Being hit by machine parts ejected through damage during use.*
- ▲ *Being caught on a rotating power take-off (PTO) shaft.*
- ▲ *Being caught in other moving parts i.e.: belts, pulleys and cutting heads.*
- ▲ *Electrocution from Overhead Power Lines (by contact with or 'flashover' from).*
- ▲ *Being hit by cutting heads or machine arms as they move.*
- ▲ *Becoming trapped between tractor and machine when hitching or unhitching.*
- ▲ *Tractor overbalancing when machine arm is extended.*
- ▲ *Injection of high-pressure oil from hydraulic hoses or couplings.*
- ▲ *Machine overbalancing when freestanding (out of use).*
- ▲ *Road traffic accidents due to collision or debris on the road.*

## **BEFORE USING THIS MACHINE YOU MUST:**

- ▲ *Ensure you read all sections of the operator handbook.*
- ▲ *Ensure the operator is, or has been, properly trained to use the machine.*
- ▲ *Ensure the operator has been issued with and reads the operator handbook.*
- ▲ *Ensure the operator understands and follows the instructions in operator handbook.*
- ▲ *Ensure the tractor front, rear and side(s) are fitted with metal mesh or polycarbonate guards of suitable size and strength to protect the operator against thrown debris or parts.*
- ▲ *Ensure tractor guards are fitted correctly, are undamaged and kept properly maintained.*
- ▲ *Ensure that all machine guards are in position, are undamaged, and are kept maintained in accordance with the manufacturer's recommendations.*
- ▲ *Ensure flails and their fixings are of a type recommended by the manufacturer, are securely attached and that none are missing or damaged.*
- ▲ *Ensure hydraulic pipes are carefully and correctly routed to avoid damage by chaffing, stretching or pinching and that they are held in place with the correct fittings.*
- ▲ *Always follow the manufacturer's instructions for attachment and removal of the machine from the tractor.*
- ▲ *Check that the machine fittings and couplings are in good condition.*
- ▲ *Ensure the tractor meets the minimum weight recommendations of the machine's manufacturer and that ballast is used as necessary.*
- ▲ *Always inspect the work area thoroughly before starting to note obstacles and remove wire, bottles, cans and other debris.*
- ▲ *Use clear suitably sized warning signs to alert others to the nature of the machine working within that area. Signs should be placed at both ends of the work site. (It is recommended that signs used are of a size and type specified by the Department of Transport and positioned in accordance with their, and the Local Highways Authority, guidelines).*
- ▲ *Ensure the operator is protected from noise. Ear defenders should be worn and tractor cab doors and windows must be kept closed. Machine controls should be routed through proprietary openings in the cab to enable all windows to be shut fully.*
- ▲ *Always work at a safe speed taking account of the conditions i.e.: terrain, highway proximity and obstacles around and above the machine. Extra special attention should be applied to Overhead Power Lines. Some of our machines are capable of reach in excess of 8 metres (26 feet) this means they have the potential to well exceed, by possibly 3 metres (9' 9"), the lowest legal minimum height of 5.2 metres from the ground for 11,000 and 33,000 volt power lines. It cannot be stressed enough the dangers that surround this capability, it is therefore vital that the operator is fully aware of the maximum height and reach of the machine, and that they are fully conversant with all aspects regarding the safe minimum distances that apply when working with machines in close proximity to Power Lines. (Further information on this subject can be obtained from the Health & Safety Executive or your Local Power Company).*

- ▲ *Always disengage the machine, kill the tractor engine, remove and pocket the key before dismounting for any reason.*
- ▲ *Always clear up all debris left at the work area, it may cause hazard to others.*
- ▲ *Always ensure when you remove your machine from the tractor that it is left in a safe and stable position using the stands and props provided and secured if necessary.*

#### **WHEN NOT TO USE THIS MACHINE:**

- ▲ *Never attempt to use this machine if you have not been trained to do so.*
- ▲ *Never use a machine until you have read and understood the operator handbook, are familiar with it, and practiced the controls.*
- ▲ *Never use a machine that is poorly maintained.*
- ▲ *Never use a machine if guards are missing or damaged.*
- ▲ *Never use a machine on which the hydraulic system shows signs of wear or damage.*
- ▲ *Never fit, or use, a machine on a tractor that does not meet the manufacturer's minimum specification level.*
- ▲ *Never use a machine fitted to a tractor that does not have suitable front, rear and side(s) cab guarding made of metal mesh or polycarbonate.*
- ▲ *Never use the machine if the tractor cab guarding is damaged, deteriorating or badly fitted.*
- ▲ *Never turn a machine cutting head to an angle that causes debris to be ejected towards the cab.*
- ▲ *Never start or continue to work a machine if people are nearby or approaching - Stop and wait until they are at a safe distance before continuing. WARNING: Some Cutting Heads may continue to 'freewheel' for up to 40 seconds after being stopped.*
- ▲ *Never attempt to use a machine on materials in excess of its capability.*
- ▲ *Never use a machine to perform a task it has not been designed to do.*
- ▲ *Never operate the tractor or machine controls from any position other than from the driving seat, especially whilst hitching or unhitching the machine.*
- ▲ *Never carry out maintenance of a machine or a tractor whilst the engine is running – the engine should be switched off, the key removed and pocketed.*
- ▲ *Never leave a machine unattended in a raised position – it should be lowered to the ground in a safe position on a level firm site.*
- ▲ *Never leave a tractor with the key in or the engine running.*
- ▲ *Never carry out maintenance on any part or component of a machine that is raised unless that part or component has been properly substantially braced or supported.*
- ▲ *Never attempt to detect a hydraulic leak with your hand – use a piece of cardboard.*
- ▲ *Never allow children near to, or play on, a tractor or machine under any circumstances.*

## ADDITIONAL SAFETY ADVICE

### Training

Operators need to be competent and fully capable of operating this machine in a safe and efficient way prior to attempting to use it in any public place. We advise therefore that the prospective operator make use of relevant training courses available such as those run by the Agricultural Training Board, Agricultural Colleges, Dealers and McConnel.

### Working in Public Places

When working in public places such as roadsides, consideration should be paid to others in the vicinity. Stop the machine immediately when pedestrians, cyclists and horse riders etc. pass. Restart only when they are at a distance that causes no risk to their safety.

### Warning Signs

It is advisable that any working area be covered by suitable warning signs and statutory in public places. Signs should be highly visible and well placed in order to give clear advanced warning of the hazard. Contact the Department of Transport or your Local Highways Authority to obtain detailed information on this subject. The latter should be contacted prior to working on the public highway advising them of the time and location of the intended work asking what is required by way of signs and procedure. – ‘*Non-authorised placement of road signs may create offences under the Highways Act*’.

### Suggested Warning Signs Required

**“Road works ahead”** warning sign with a supplementary **“Hedge cutting”** plate. **“For 1 mile”** or appropriate shorter distance may be added to the plate.

**“Road narrows”** warning sign with supplementary **“Single file traffic”** plate.

White on blue **“Keep right”** (\*) arrow sign on rear of machine.

\* Note – this applies to UK Market machines where traffic passes to the right of a machine working in the same direction as the traffic flow. The direction, use and colour of the arrow sign will depend on the country of use and the Local Highway Authorities regulations in the locality.

### Use of Warning Signs

- ▲ On two-way roads one set of signs is needed facing traffic in each direction.
- ▲ Work should be within 1 mile of the signs.
- ▲ Work only when visibility is good and at times of low risk e.g.: NOT during ‘rush-hour’.
- ▲ Vehicles should have an amber-flashing beacon.
- ▲ Ideally, vehicles should be conspicuously coloured.
- ▲ Debris should be removed from the road and path as soon as practicable, and at regular intervals, wearing high visibility clothing and before removing the hazard warning signs.
- ▲ Collect all road signs promptly when the job is completed.

---

Although the information given here covers a wide range of safety subjects, it is impossible to predict every eventuality that can occur under differing circumstances whilst operating this machine. No advice given here can replace ‘good common sense’ and ‘total awareness’ at all times, but will go a long way towards the safe use of your McConnel machine.

---

## VEHICLE /TRACTOR PREPARATION

We recommend vehicles are fitted with cabs using 'safety glass' windows and protective guarding when used with our machines.

**Fit Operator Guard** (*part no. 73 13 324*) using the hooks provided. Shape the mesh to cover all vulnerable areas.

**Remember** the driver must be looking through mesh and/or polycarbonate glazing

when viewing the flail head in any working position - unless the vehicle/ cab manufacturer can demonstrate that the penetration resistance is equivalent to, or higher than, that provided by mesh/polycarbonate glazing. If the tractor has a roll bar only, a frame must be made to carry both mesh and polycarbonate glazing. The operator should also use personal protective equipment to reduce the risk of serious injury such as; eye protection (*mesh visor to EN1731 or safety glasses to EN166*), hearing protection to EN352, safety helmet to EN297, gloves, filter mask and high visibility clothing.

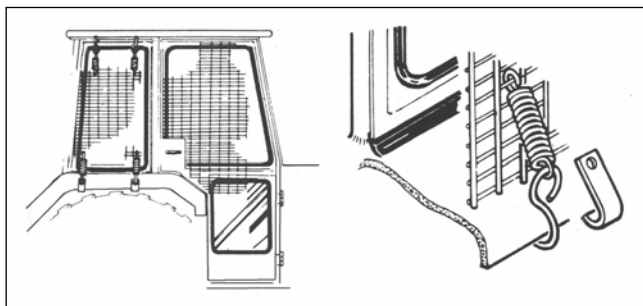

**Vehicle Ballast:** It is imperative when attaching 'third-party' equipment to a vehicle that the maximum possible stability of the machine and vehicle combination is achieved – this can be accomplished by the utilisation of 'ballast' in order to counter-balance the additional equipment added.

**Front weights** may be required for rear mounted machines to place 15% of total outfit weight on the front axle for stable transport on the road and to reduce 'crabbing' due to the drag of the cutting unit when working on the ground.

**Rear weights** may be required to maintain a reasonable amount of rear axle load on the opposite wheel from the arms when in work; for normal off-ground work i.e. hedge cutting this should be 20% of rear axle weight or more for adequate control, and for ground work i.e. verge mowing with experienced operators, this can be reduced to 10%.

All factors must be addressed in order to match the type and nature of the equipment added to the circumstances under which it will be used – in the instance of Power Arm Hedgecutters it must be remembered that the machines centre of gravity during work will be constantly moving and will differ from that during transport mode, therefore balance becomes critical.

### **Factors that effect stability:**

- Centre of gravity of the tractor/machine combination.
- Geometric conditions, e.g. position of the cutting head and ballast.
- Weight, track width and wheelbase of the tractor.
- Acceleration, braking, turning and the relative position of the cutting head during these operations.
- Ground conditions, e.g. slope, grip, load capability of the soil/surface.
- Rigidity of implement mounting.

### **Suggestions to increase stability:**

- Increasing rear wheel track; a vehicle with a wider wheel track is more stable.
- Ballasting the wheel; it is preferable to use external weights but liquid can be added to around 75% of the tyre volume – water with anti-freeze or the heavier Calcium Chloride alternative can be used.
- Addition of weights – care should be taken in selecting the location of the weights to ensure they are added to a position that offers the greatest advantage.
- Front axle locking, check with tractor manufacturer.

The advice above is offered as a guide for stability only and is not a guide to vehicle strength. It is therefore recommended that you consult your vehicle manufacturer or local dealer to obtain specific advice on this subject, additionally advice should be sought from a tyre specialist with regard to tyre pressures and ratings suitable for the type and nature of the machine you intend to fit.

# P.T.O. DRIVE SHAFT SAFETY PRECAUTIONS

**DANGER** ON EACH TRACTOR CHECK:-



Ensure the correct end of the drive shaft is fitted to the tractor.. See labels on the drive shaft.

Check carefully that the drive shaft does not bottom out and that a minimum of 6" (150mm) of engagement is maintained.

Ensure that the guards are always in position, can rotate freely and the check chains are not stretched when the machine is raised or lowered.

Check that when in the continuous working position the drive shaft is not at an angle of more than 20 degrees to the P.T.O. centre line.

Ensure the drive shaft does not foul the tractor P.T.O. guard, the gearbox input shield or the tractor drawbar.



# FITTING

## TRACTOR SELECTION

### Horse power and weight requirements

The Power Arm 91 requires a tractor with a minimum of 30 HP in conjunction with a minimum weight of 1500Kg (1.5 tons imp. 1.6 tons U.S.) If it is necessary to add ballast to achieve this weight check in the tractors handbook that it does not exceed the maximum allowed.

Bear in mind that these are minimum requirements for optimum working conditions. Tractor selection must take into account the type of terrain upon which it is proposed to operate and the degree of stability required.

### Linkage requirements

The tractor must be equipped with either Cat I or Cat II linkage

### Linkage isolation

Although it may be possible to operate the semi independent version of the PA91 without linkage isolation a severe strain would be put upon the attachment yoke and pins. Most modern tractors are equipped with a ready means of providing linkage isolation through a conveniently operated valve.

Linkage isolation is not required on the fully independent model of the PA 91 and the tractors hydraulic controls should be neutralised.

### Check chains\stabilisers

To hold the machine firmly in position, check chains or stabiliser bars must be fitted. It is dangerous to operate the machine without.

### Tractor relief valve

The main relief valve in the hedger hydraulic control unit is set at 1800 PSI (125 Bar). Therefore if operating the PA 91 in semi independent form the tractors relief valve setting must be at least a little above this figure for satisfactory operation.

### Tractor hydraulic flow rates

Oil flow rates are not crucial when operating a semi independent PA91. Flow rates of up to 10 gpm (45 l/min) should not have any adverse affect to the inching response that is sometimes required from the control valve.

### P.T.O shaft

Tractor must be equipped with live drive independent PTO shaft to enable forward movement to be halted while the flail head continues to operate.

### Draft control

Loads imposed through the draft sensing mechanism will not normally be sufficient to put a strain on the tractor, however any provision for draft control should be set to minimum response. Where a draft control rocker is fitted with a dead pin position this should be utilized.

# TRACTOR PREPARATION

## Fitting operator guard

A tractor fitted with a cab that has safety glass windows should be used whenever possible. This is a basic safety precaution applicable to the use of all flail-type hedge trimmers.

Power arms are supplied with an operator guard kit part number 73 13 324 which must be fitted to the tractor before commencing work

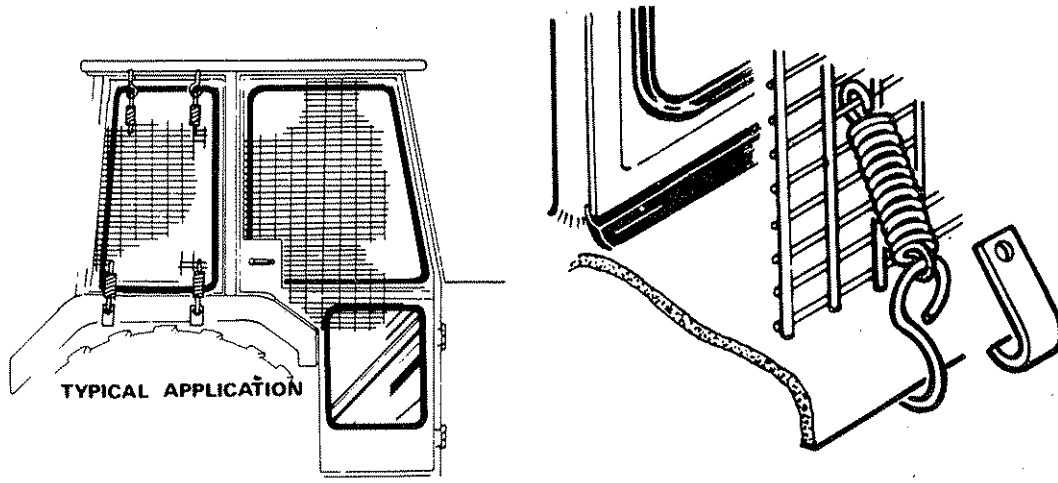

It consists of two areas of wire mesh which can be shaped to suit and secured against the cab window with spring loaded hooks, the upper edge being anchored around the cab gutter and the lower edge around the mudwing.

Owing to the great range of cabs it may be necessary to adapt or make brackets to secure the mesh.

Where the flail is operated on a tractor that is equipped with a safety frame or roll bar only, then an additional frame must be made and fixed to the tractor on to which the guard mesh can be secured. In addition to the guard mesh, a sheet of Polycarbonate transparent glazing must be fitted to the frame to provide further operator protection. This material must also be used when the cab does not have safety glass installed.

The operator guard kit supplied is suitable for all standard applications i.e. rear mounted on a conventional tractor. For other applications additional mesh guarding may need to be constructed to give adequate operator protection. A guideline to follow when assessing any additional guarding that may be required is that the operator must always be looking at the flail head through the mesh when it is in any working position.

Polycarbonate transparent sheeting is an impact resistant material which can be readily sawn and shaped to requirements. Unfortunately it is susceptible to surface damage and scratching, therefore it is advisable to place the material on the inside of the window for protection. No attempt should be made to wipe the sheeting with dirt engrained cloth.

Toughened grades of polycarbonate sheeting are available under the brand names of "Makrolon", "Tuffak", and "Lexan".

In case of difficulty in obtaining this material locally, contact F.W. McConnel Ltd through your normal dealer.

## Ballast weight

Irrespective of the size of tractor it must be stable whilst operating the hedge cutters under all conditions. Due regard must be paid to operating on slopes and front end ballast as well as rear wheel weights to counterbalance the overhang of the flail head should be added as appropriate. On steeply banked ground it may not be sufficient to depend alone on the counterweight afforded by the oil reservoir.

In addition rear wheel track should be set as wide as possible to increase stability. It will also increase the protection to the reservoir.

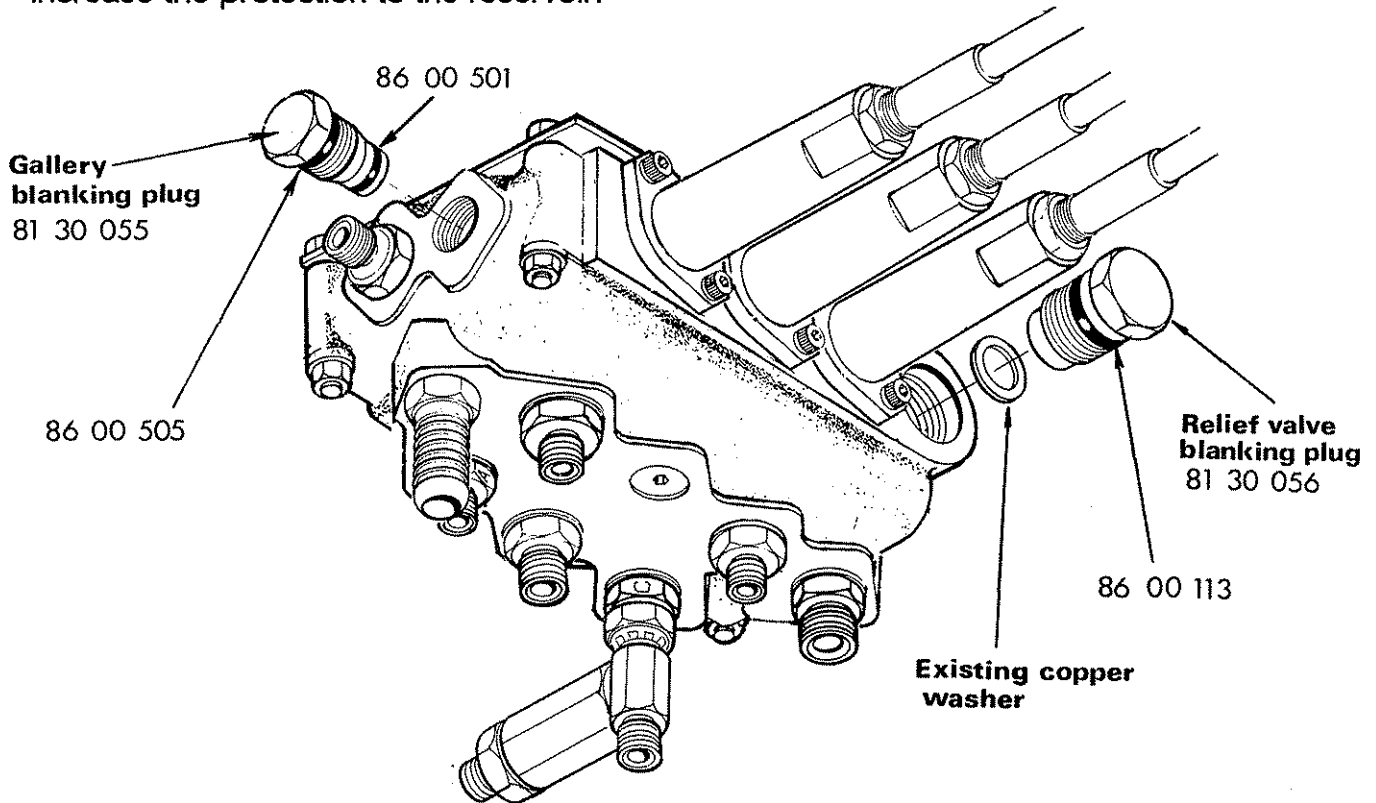

## JOHN DEERE CONVERSION KIT 81 30 059

### John Deere

The John Deere utilises a 'closed centre' hydraulic principle and because of this it is recommended to use trimmers with a fully independent hydraulic system on tractors of this manufacture. However it is practicable for the semi independent model of the PA 91 to be used with these tractors subject to certain modifications. There are the following two alternatives.

1. A flow limiting valve manufactured by John Deere is available to provide an 'open centre' external supply sufficient for PA 91 requirements. For further advice consult your John Deere dealer.

2. Components are available from F W McConnel Ltd, to convert the standard 'open centre' valve. Part No. 81-30-059 consists of a relief valve blanking plug which should be installed in place of the existing relief valve. Take care when extracting the relief valve not to damage the copper sealing washer as it is reused with the blanking plug. In addition a pressure gallery blanking plug is installed in place of the standard blanking plug at the valve outlet end next to the lift ram gland connection

When working in this mode the tractor's pressure control valve must not exceed 1800 P.S.I. (125 Bar).

## WARNING

Do not operate quadrant lever or machine controls through the rear cab window whilst standing on or amongst linkage components. Always seek assistance.

\*Measure the P.T.O. drive shaft length as shown in the diagram below and subtract 1 inch (25mm).



\*This measurement which is the fully closed final length of the P.T.O. drive shaft measured button to button should be taken carefully before the P.T.O. drive shaft is shortened to suit by cutting off both the driving and driven members of the tube by an equal amount. Likewise the plastic shield will similarly have to be cut. Take heed if too much is cut off it cannot be stuck back on. Measure twice and cut once. Accurate measurement is important on some close coupled tractors to ensure maximum engagement during operation.

Lower the machine to the ground and fit the P.T.O. shaft in position. Ensure that the collar locking devices on the P.T.O. shaft are fully engaged and wrap the torque chain around the tractor drawbar or any convenient point to prevent the shaft guard from rotating.

Raise the machine to working height

### Ti model only

Check that the rotor control valve is in the stop position.

With P.T.O. engaged on Ti model or with tractor external services activated on Si model (see page 12) select "Lift down" this will level the frame and enable the lower yoke pins to be fitted. Select the hole which will, as near as possible position the P.T.O. shaft horizontally in line.

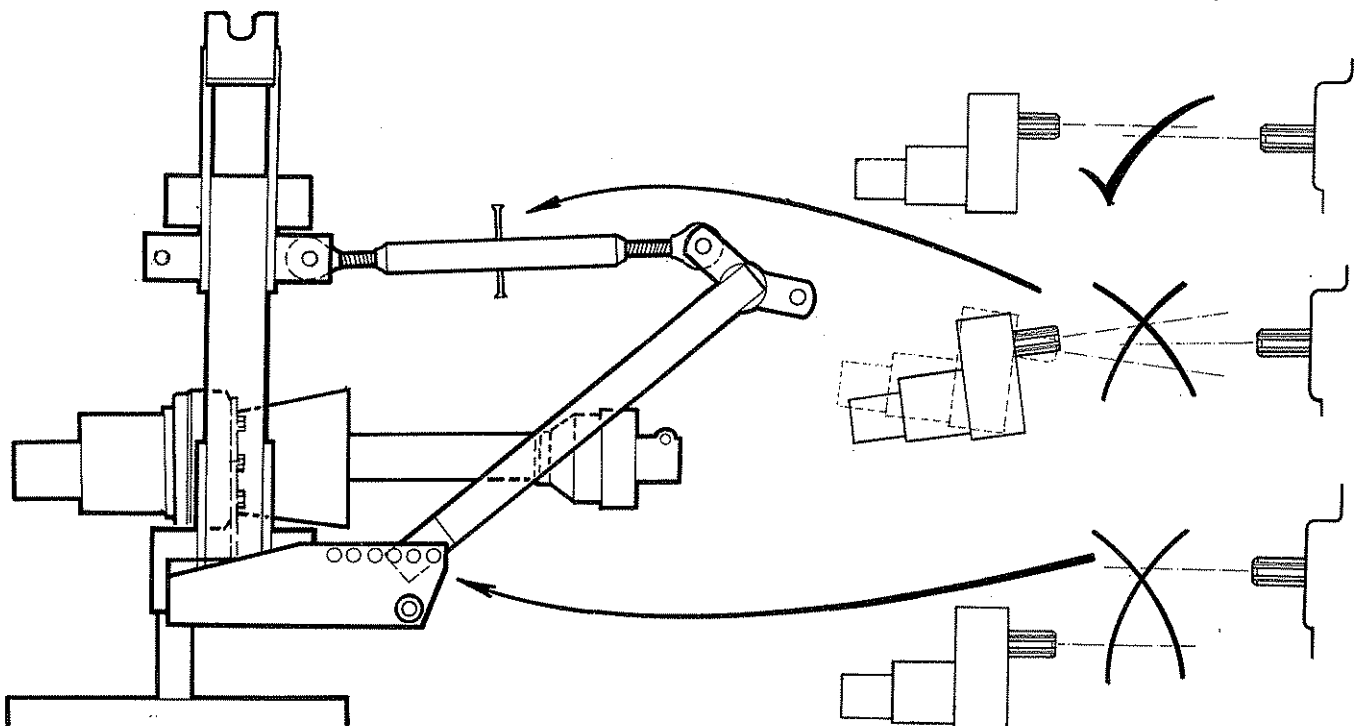

## DELIVERY

The machine is delivered in a partially dismantled condition. To make ready for attachment to the tractor it will be necessary to:-

Select a hard level surface

\*Cut the banding straps and remove the attached articles

\*Fill the reservoir to capacity with oil selected from the chart on page 16 to increase the stability of the machine.

\*Remove and discard the transport strap connecting the flail head to the frame and also the lift ram stop strapped to the rod.

## ATTACHMENT TO TRACTOR

On Si model drive the tractor up as closely as possible and connect the return and supply hoses to the tractor. Fit suitable return connection to the tractor and connect the return hose before connecting the supply hose to the tractors external services point with a suitable self seal coupling.

\*With the aid of a crowbar prise the flail head sideways until there is sufficient clearance to allow the tractor to be driven up and the draft links connected. Assistance will be needed to simultaneously select "Reach out" and "angle down" to allow the oil to flow whilst the arms are being moved.

### WARNING

As a safety precaution to prevent the possibility of the flail head slipping sideways and the arm collapsing on the fitter as he is prying the head sideways a loop of strong rope or wire, with sufficient slack to allow the required flail head movement should connect the frame and dipper. This will then act as an arrestor in the event of this happening. Leave in position until attachment is complete.

Swing up the linkage plate and fix securely in position with the nut and bolt provided.

Adjust tractor drop arms to enable the draft links to lower within 15 ins (375mm) of the ground.

Remove the top link and machine yoke completely.

Reverse the tractor squarely to the front of the machine, engage draft link pins and secure.

Attach yoke to the top hitch position on the tractor ensuring the lug for the top link is uppermost.

Unlimber the machine controls from its storage position and fit into the tractor cab. see page 10

Install the top link between yoke and upper hitch position on the machine., If necessary fitting Cat. 1 sleeves into the ball ends of the top link.

\*Raise the machine on its three point linkage to the working height i.e. when the PTO shaft and the gearbox stub shaft are as near as possible in a straight line.

Lower the quadrant lever so that the machines weight is taken by the yoke.

Adjust the top link to bring the pillar upright

\*Remove the rope arrestor loop.

Carry out final adjustment of the tractor lift arm levelling box to bring the main frame horizontal. This should be checked with the arms at approximately half reach with the flail head clear of the ground.

Tighten up the check chains or adjustable stabilisers to hold the machine rigid without side-sway.

Raise the parking feet in their sockets and secure in the transport position.

Carefully operate the machine through its full range of movement whilst checking that the hoses are not strained, pinched, chaffed or kinked and that all movements are functioning correctly.

Assemble the front hood to the flail head.

Fold the machine into the transport position (see page 20)

The machine is now ready to proceed to the work site.

This procedure is for initial attachment only, for subsequent attachment paras marked \* do not apply.

If it is required to mount the machine on a different tractor bear in mind that the engagement of the P.T.O. shaft will alter. A safe minimum engagement between the two halves of the shaft is 6". This dimension must be checked before work is commenced.

## FITTING CONTROL UNIT IN CAB

The 3 lever control unit which is cable operated is mounted on an adjustable stalk that is attached to a seat bracket which is of universal design for mounting in many models of tractor. The bracket is normally trapped between the seat runners and their mounting base. It may sometimes be necessary to drill extra holes in the seat bracket to find the ideal operator position.

On tractors other than quiet cab models it is permissible to attach the control unit to the mudwing or the cladding of the cab observing the precaution that no structural member of the safety frame should be drilled. For this purpose the mounting stalk can be bent round in a 'U' shape.

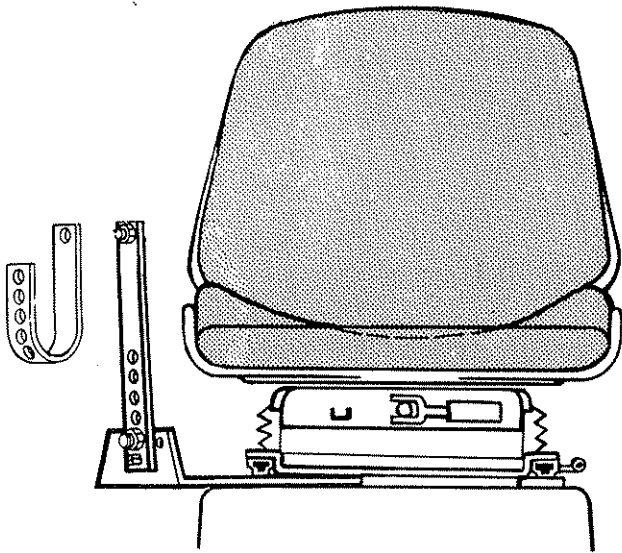
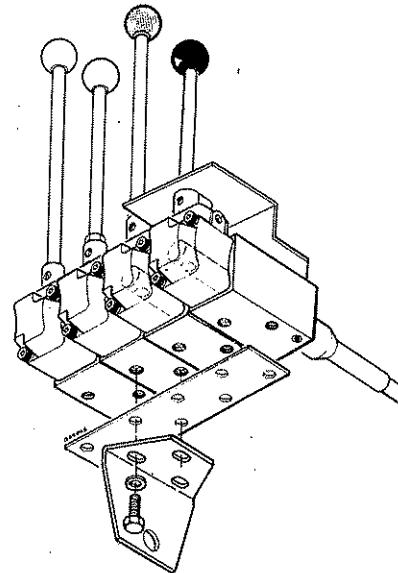
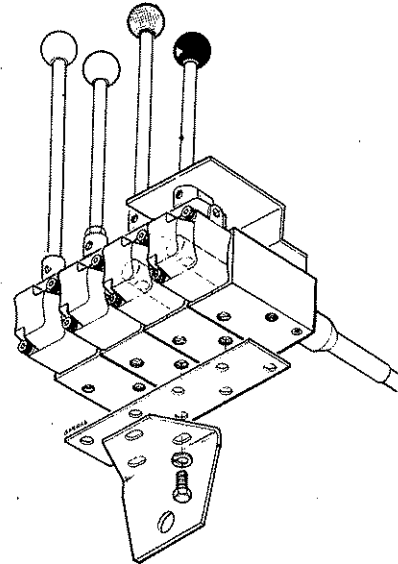

illustration shows Ti model.  
Rotor control lever can be mounted  
either end of main controls



The control unit itself is bolted to an angled mounting bracket in either a transverse or longitudinal position thus giving a variety of mounting position, which in conjunction with flexibility of the mounting pillar will enable a satisfactory working position to be achieved.

Shown above is detail of alternative fitting of the mounting spigot. In deciding the final position of the control box remember that tight bends in the cables will reduce their operational life. Do not exceed the minimum acceptable bend radii of 8".

The handles may be screwed into alternative holes in the levers to give an 'in line' installation should it be desirable

## OIL REQUIREMENTS

### Tank

The machine is delivered from the factory without oil. Fill the reservoir with a light hydraulic oil as recommended in the chart until the oil level is approximately 2" below the top of the tank. The total capacity is approximately 90 litres (20 galls) .Do not overfill.

The oil must have anti-frothing characteristics suitable for use in hydraulic systems.

Supplier	Cold or temperate climate	Hot climate
Castrol	Agricastrol hydraulic oil Hy-spin AWS32	Hy-spin AWS68
Shell	Tellus 32	Tellus 68
Mobil	D.T.E. 25	D.T.E. 26
Esso	Nuto 'H' or 'A' 32	Nuto 'H' or 'A' 68
Texaco	Rando HD 32	Rando HD 68
Gulf	Hydrasil 32	Hydrasil 68
B.P.	Energal HLP 32	Energal HLP 68
Dalton	Silkolene Dove 32 or Derwnet 32	Silkolene Dove 68
Elf	Hydrelf 32	Hydrelf 68
ISO VG	32	68
SAE	10W	20

### Gearbox

Check the gearbox oil level. On level ground gearbox should be filled until oil is visible level with the lip of the filler plug aperture. Do not attempt to fill by removing the breather as the depth of tapped thread in the casing at this point is insufficient to allow repeated loosening and tightening of the breather plug.

The gearbox capacity is 700 millilitres (1 1/4 pint) use EP 90 gear oil.



## **RUNNING UP PROCEDURE**

### **PA 91 Ti**

Ensure that the rotor control valve is in "STOP" position, start tractor, engage P.T.O. and allow the oil to circulate for about 5 minutes without operation of the armhead control lever. This will allow all the oil to circulate thoroughly through the return line filter.

Operate the armhead levers through their complete range ensuring that all movements are functioning correctly.

Place the flail head at a safe attitude and move the rotor control to "ON" position. After initial fluctuation due to priming the rotor should settle to a steady speed. Increase P.T.O. speed to approximately 360 rpm. and run for a further five minutes before disengaging and stopping tractor.

Check the hose runs and observe that they are free from any pinching, chafing straining or kinks. Re-check the oil level in the tank and top up as necessary.

### **PA91 Si**

Ensure P.T.O. lever is in neutral position, and isolate tractor hydraulic linkage. Start tractor and select external service supply on the hydraulic controls. Allow the tractor to run for several minutes before attempting to operate any of the machine control levers.

On operating move the levers through their complete range ensuring that all movements are functioning correctly.

Check the tractor rear axle oil level and top up if necessary.

Place the flail head at a safe attitude and bring tractor engine revolutions to 1000 rpm. to avoid stalling when the starting load is placed on the motor. Engage P.T.O. and allow the rotor to run for several minutes. Do not leave the tractor cab or allow anyone to approach the flail head at this time.

### **Caution**

Do not allow the pump to continue working if the rotor does not turn-Overheating and serious damage to the pump can be caused in a very short time.

After running up the machine increase P.T.O. speed to approximately 360 rpm. and run for a further five minutes before disengaging the P.T.O. and stopping tractor. The reason for this running period under a no load condition is to thoroughly circulate the oil in the reservoir through the return line filter.

Check the hose runs and observe that they are free from any pinching, chafing, straining or kinks. Re-check the oil level in the tank and top up as necessary.

## **REMOVAL FROM TRACTOR**

Select a firm level site for parking the machine

Lower the parking legs and secure.

Operate the hydraulic service to place the arms at half to three quarters reach and with the flail head roller horizontal and level with the bottom of the parking feet.

Disengage tractor P.T.O and remove.

Disconnect stabilizer bars or loosen check chains as applicable.

Unbolt the control unit from the mounting pillar, remove from tractor cab and stow in a suitable location clear of the ground. On Si models only the supply and return hoses must be disconnected from the tractor and stowed with their ends covered and clear of the ground

Raise the machine on the tractors linkage to take the weight off the yoke and remove the lower yoke bolts.

Lower the tractor draft links and place machine firmly on the ground.

Remove draft links and top link from the machine, drive tractor away and remove yoke. Blank off the end of the return hose with plug or small plastic bag if a self seal coupling is not fitted.

## **STORAGE**

If machine is to be left standing for an extended period of time, lightly coat the exposed portions of the ram rods with grease. Subsequently this grease which becomes contaminated with dust and grit should be wiped off before the rams are next moved.

If the machine has to be stored outside tie a piece of tarpaulin or canvas over the control assembly - do not use a plastic fertilizer bag which could lead to rapid corrosion.

# OPERATION

## LIMITATION

The Power Arm 91 has been designed as a light weight trimmer and is ideal for work on hedges that have been regularly maintained and is capable of cutting up to two years growth. Attempting to cut older, heavier material will lead to increased wear, premature breakdown and may invalidate your warranty. The machine can be operated on either side of the tractor and the rotor has been designed to cut in either direction. Heavily overgrown or badly neglected hedges should be tackled with a heavy duty hedger or in extremes, with a shapersaw.

## HIGHWAY WORKING

If it is intended to cut roadside hedges or to work in the vicinity where the public have access, it is a statutory requirement that suitable warning signs are placed at both ends of the work area. These signs should not be more than half mile apart (.75KM). To further promote highway safety, the use of headlamps and a flashing beacon on the cab roof would be beneficial. Hazard warning lamps should not be used since an oncoming vehicle could easily misjudge braking distance in presuming the tractor approaching them is stationary.

### **WARNING**

Always keep any bystanders at a safe distance and ensure that they do not stand in the potential line of any debris that may be thrown.

## OPERATORS GUARD

Owner are reminded that it is illegal to use a flail without an efficient operator guard. The guard supplied as standard equipment with each machine attaches to the tractor cab with spring loaded hooks.

## PREPARATION

Before commencing work, the operator should read the instruction manual thoroughly, paying particular attention to the SAFETY PRECAUTIONS printed in the front of the manual. It is the operator's responsibility to ensure that a safe code of practise is followed.

If the operator is unfamiliar with the control levers and thus the reach, height and angling of the flail head, a worthwhile exercise is to, before commencing work choose a clear unobstructed site and operate the arms throughout their range of movement until the response to the controls and the 'feel' of the machine are familiar. Test yourself by making a dummy run alongside the hedge with the rotor stationary. This is a wise precaution for all operators and a must for the inexperienced.

### **Caution**

The ability for the flail head to work closely alongside the tractor wheel in narrow lanes and for transport to fold within the overall tractor width can present a possible hazard for the flail head to contact the mudwing, rear lamp cluster etc, and cause damage.

### **Caution**

should be exercised when operating under these conditions and particularly when folding within the tractors width for transport.

## MACHINE CONTROLS

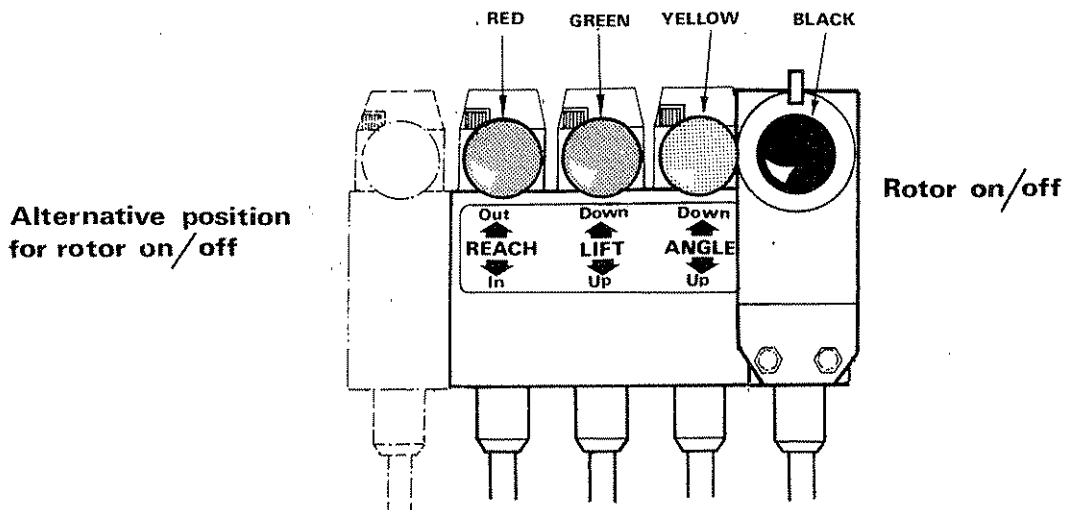

Moving the arm control levers away from the cables will result in "Lift down", "Angle down" and "Reach out".

For Ti models only the Flail on/off valve can be mounted on either end of the main control block. It is delivered with the lever control gate set in the position limiting the lever selection to "Flail off" and "Flail on - upwards cut". Should a downward cut be required the lever gate can be rotated to allow a "Flail off" and "Flail on - downward cut" selection.

Before making this adjustment disengage the P.T.O. shaft and ensure that the rotor has stopped rotating.

Do not be tempted to discard the lever gate - it is there to prevent sudden, inadvertent changes of rotation which could cause damage to the machine.

## TRANSPORT POSITION

For transport on the public highway the flail must be folded within the overall width of the tractor.

To achieve this:-

Position the arm until the flail head is approximately four feet (1.5m) clear of the ground and the dipper is horizontal.

Pull the dipper arm to the rear to remove tension on the breakaway ram base pin and remove it.

Manually break back the dipper until the base of the ram is re located between the inboard holes in the ram lugs. Replace the ram base pin.

Select 'Reach In' and Lift up' until the main arm abuts against the stop on the top of the main frame. Fully extend the angle ram to face the flails inboard.

Remove the transport lock pin from its stowage position beneath the main arm and locate in position through the retaining peg. Secure with spring cotter.

For off road transport where width is not critical it will be sufficient to fully fold the arms, and engage the lock pin.

To revert to 'work' mode the above procedures must be reversed.

## **ENGAGING DRIVE**

### **a) Fully independent model**

Ensure that the rotor control lever is moved to the 'STOP' position before engaging the P.T.O. shaft. Allow the oil to circulate for a minute or so before operating the armhead levers. Position the flail head in a safe position, increase the engine speed to a high idle and move rotor control lever to 'ON'. After initial surging the rotor will run at an even speed. Starting the rotor this way reduces the starting loads imposed on the hydraulic motor and the drive splines.

### **b) Tractor supply model**

Place the flail head at a safe attitude and bring the tractor engine revolutions to 1000 r.p.m. to avoid stalling when the starting load is placed on the motor. Engage the P.T.O. and slowly increase revs. until operating speeds are attained.

## **FORWARD SPEED**

Tractor ground speed is determined by common sense and experience. It should be slow enough to allow sufficient time for the flails to cut the work without overloading. It is obviously better to make a second pass or more in heavier growth to avoid undue strain.

## **TRACTOR POSITION**

The position of the tractor in relation to the hedgerow will again be determined by experience. For a normal straight forward hedgerow the position should be such as to allow the reach ram to be in mid-stroke. This effectively allows the reach to be adjusted in either direction without altering the tractor's position.

## **OPERATING SPEED**

The flail head should be run at a speed no higher than is needed to make a clean cut with no fall off in rotor speed. This also allows better control of the tractor and reduces the tendency of the operator to 'ride the clutch pedal'.

The recommended rotor speed is 2500 rpm.

To achieve these speeds it will be necessary to run the tractor engine to give a P.T.O. speed of 450 r.p.m.

<p style="text-align: center;"><b>WARNING</b> Never exceed 540 rpm on the P.T.O. shaft</p>
--

## **WORKING PRACTISES**

It is the operators responsibility to develop safe working procedures. From the first, develop good habits not bad ones, always:-Make sure all guards are in position and in good condition.

Disengage the P.T.O. before stopping the engine.

Wait until the flail has stopped rotating before leaving the tractor seat.

Disengage the P.T.O. and stop the tractor engine before making any adjustments.

Check frequently that all nuts and bolts are tight.

Always use the recommended position when transporting on the highway.

## WORKING CLOSE IN AND HIGH

When attempting to position the flail head to cut close in and high the main arm may abut against the stop before the required head position is achieved. If this occurs select "Reach out", this will cause the main arm to lift off the stop allowing the "Lift up" motion to be continued on service selection.

By use of this technique it is possible to position the flail head in the close in position from ground level to full height.

## BREAKAWAY

The pivoted arm is held rigid and in line by the oil pressure in the fully extended breakaway ram. When the flail head meets an obstruction and the tractor continues to move forward oil pressure will build up, against a relief valve situated in the base of the breakaway ram. When the preset pressure is reached the valve will blow and the oil will be vented into the lift ram. This will allow the flail head to pivot backwards and at the same time cause the arms to rise. When the obstruction is cleared oil pressure contained in the lift ram will cause the arm and flail head to return to the work position.

## OVERHEAD OBSTRUCTIONS

Remember the machines are approximately eleven feet high in the folded position and therefore care must be taken when manoeuvring in and out of buildings or in the vicinity of overhead obstructions such as power lines or telephone cables.

### WARNING

To avoid the possibility of flashover in the vicinity of high voltage overhead power lines never work closer than 1.5 metres minimum. If in any doubt consult the local electricity board or leave officer for advice on a safe plan of working.

## WIRE TRAP

The flail hood is equipped with a wire trap. The trap consists of a steel plate welded across the underside. Any loose ends of wire which are picked up and carried round by the rotor are cut by the edge of the metal plate and fall harmlessly to the ground. This plate should not be interfered with or modified in any way.

Furthermore this wire trap does not relieve the operator of the responsibility of checking and cleaning the flail when it is suspected that wire has caught in the rotor.

### WARNING

If any wire is picked up by the rotor the machines should be stopped immediately and the rotor cleared before proceeding.

# HEDGE CUTTING PROCEDURE

## Preliminary precautions

The work area or hedgerow should be carefully inspected for wire, steel posts, large stones, bottles and other dangerous materials and removed. The position of any immovable objects should be particularly noted or identified i.e. with a fragment of plastic sack to avoid running into them with the flail. Should the rotor accidentally strike anything of a hazardous nature, the machine should be immediately stopped and the rotor examined for damage or missing flails which should be replaced to retain rotor balance. Continuing to work the flail head with the rotor out of balance will cause vibration which can rapidly damage the rotor bearings and break up the flail casing.

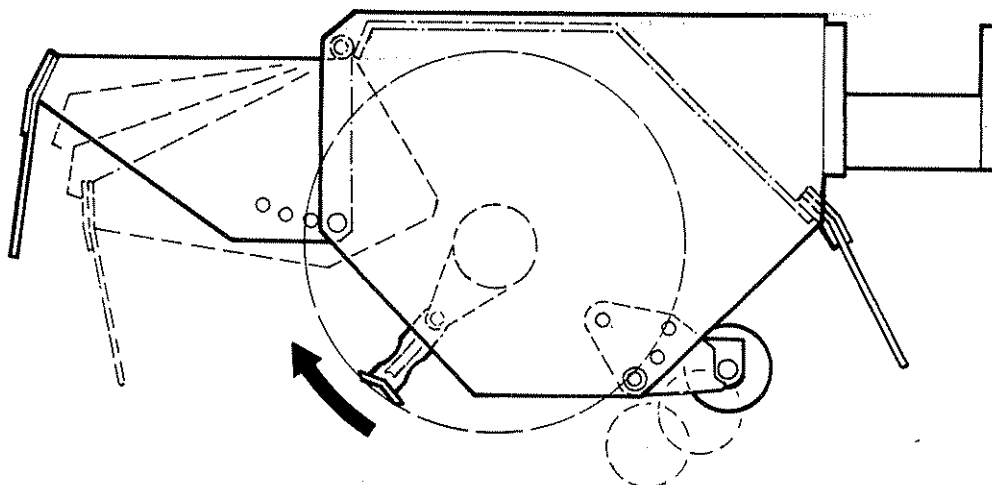

## Upward Cutting

The flail head is assembled at the factory for the flails to cut with an upward motion. Upward cutting produces a cleaner finish minimises split stems and is ideal for a light hedge that has been regularly maintained. The front hood and rear flap must always be in position when hedging with an upward cutting action. The front hood is pivot mounted and can be adjusted to four working positions. To minimise the throwing of debris especially when roadside cutting the hood should be adjusted to its lowest position. Raising the hood will allow longer material to be cut but there will be a greater tendency for debris to be thrown.

## Roller

The roller is adjustable vertically to three positions. For hedge cutting it is generally set in the highest position which positions the roller slightly above the flails. The roller helps to prevent the flail head from bouncing and sinking into the hedge thus assisting in maintaining a level cut. The two lower positions may be used when making the ground cuts. These locate the roller below the flails which prevents the scalping of the earth and decreases the likelihood of hitting or throwing stones. Never attempt to operate the flail without the roller in position. It shields the flails, acts as a chopping bar and eliminates the chances of long lengths of cut material being thrown.

## Front flap kit

To further reduce the possibility of debris being thrown out of the front of the hood a flap kit consisting of seven rubber flaps which are attached to the leading edge of front hood is available.

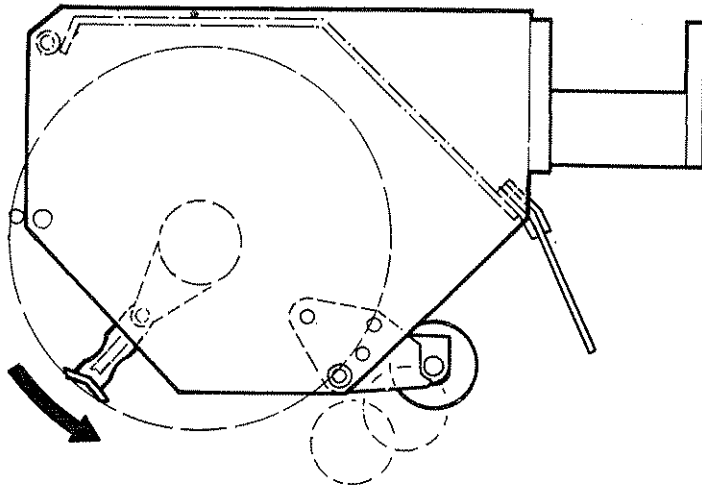

### Optional Downward Cutting

It is possible to reverse the rotation of the flail for downward cutting. This chopping action subjects the rotor to a more violent usage and should therefore be avoided whenever possible.

#### For downward cutting

The rear flap must always remain in position to deflect the cut material downwards into the hedge. Because of the tendency to throw material out of the rear of the hood when downward cutting it is especially important that the rear flap is kept in good condition. It is permissible to remove the front hood to allow longer material to pass under the flail head.

#### Reversing rotation (Si only)

Fully extend the armhead and lower flail to the ground to minimise oil loss. Release the rotor hoses from either the flail motor or the rotor control valve and interchange the connections. Do not cross over the flail supply and return hoses at any other point as the hose routing and cross overs in the installation are necessary to allow the hoses to flex correctly during arm movements.

To ascertain the direction of cut without running the machine the following applies.

Connection MP - lower motor connection } upward cutting  
 Connection MR - upper motor connection }

Connection MP - Upper motor connection } downward cutting  
 Connection MR - Lower motor connection }

#### Reversing rotation Ti Only

The flail rotor rotation can be reversed using the rotor control lever. Place the lever in the 'Off' position and rotate the lever stop gate through 180 degrees. This allows the selection of 'On' and 'downward rotation'.

**Caution.** Do not remove the lever stop gate as it prevents the unintentional instant reversal of rotation and the likely machine damage that would be caused as a result.



## Hedge -shape

Local practice and customs as well as the requirement; be it a shockproof barrier, a windbreak to resist soil erosion or as a sanctuary to protect wild life will have their part to play in influencing the desired finished shape of the hedgerow.

A hedge cut in the shape of an 'A' although rather wider and so taking up more ground will be encouraged to send out new growth from the bottom. The stubby ends from the ground to the top can further discourage stock and the wide dense bottom will promote conservation of wild life.

A hedge with vertical sides and an apex top is an alternative which has found favour in many parts of the country. The sloping top encourages light to penetrate and promote growth in the lower regions of the hedge. The sloping top also assists to shed heavy falls of snow which can accumulate and break a hedge down.

Although a box-shaped hedge, flat across the top and with square corners may look very tidy in its early stages it is prone to dying off in the bottom while being encouraged to grow in the top. After a few years this type of hedge can become 'buck-headed' and is always susceptible to damage by snow.

## Cutting sequence

Operator preference will ultimately decide on the order of cutting. Where it is difficult to determine the original hedge line because of overgrowth a recommended method is to start by siding up the hedge first, if necessary making more than one pass.

A second cut should then be taken at an incline along the hedge top and again if there is prolific growth it may be necessary to make more than one pass until the hedge is reduced to the height and contour required.

Finally, finish with a ground cut and for this, the roller should be lowered. This ground cut defines the base line of the hedge, severs brambles and rubbish that encroach out from the bottom, and further mulches the toppings that have fallen.

### Note:

Flails are more prone to accidental damage and blunting by stones on a ground cut. Therefore when convenient this should be left to the last.

Where the hedge has been well maintained in the past it may be found better to cut the top before siding up.

### **WARNING**

Do not be tempted to make a vertical cut on the far side of the hedge. This would entail cutting 'blind' and the rotating flail would be capable of throwing debris through the hedgerow in line with the operator.

Where both sides of a roadside hedge are to cut, always cut the field side first. The uncut roadside helps to reduce the amount of debris being flung through the hedge into the road. Also by sloping the vertical cut to give an 'A' shape, debris is thrown down into the hedge bottom and the spread of material is reduced.

## **LIFT FLOAT KIT (optional Extra)**

The hydraulic float kit is bolted to the face of the valve mounting stalk with the bottle downwards

The existing hose to the lift ram is discarded.

The short hose connects the valve and the float kit tap using the union from the lift ram base at the tap end.

The long hose connects the float kit tap and lift ram base using the connections supplied.

In work, with the tap open the flail head automatically follows the ground contours.

The lift control should be operated to take a proportion of the flail head weight off the flail roller. This is important, too little weight on the roller will leave uncut areas of grass while with too much weight on the roller the ground will be scalped in places and increased wear, loss, or damage to the flails could occur.

To revert to hedge cutting or to use the flail without it running along the ground the stop tap should be closed to isolate the accumulator.

## **HEAD ANGLE FLOAT**

In addition to the normal range of the head angle controls a head angle 'float' position can be selected which allows the flail head to automatically angle itself to follow the contours of the ground when grass cutting. To obtain this position the control lever must be pushed away from the operator beyond its normal range until it locks into the float position. To return to normal operation the float position must be manually deselected.

## FLAIL TYPES

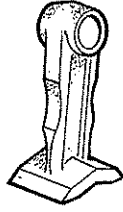

**F 91 H**



**F 91 G**

Two types of flail are available:-The F91 H is a cast flail suitable for continuous hedge and scrub cutting. It will also cut grass but the finish will be inferior to that produced by the F91G and the power requirements greater.

The F91G is a pressed flail suitable for grass and scrub cutting. It can also be used to cut hedges but continuous use in this material will noticeably shorten its working life.

### MACHINE CONFIGURATION

The machine can be supplied to be either front or rear mounted and to cut on the right or left side of the tractor. Conversion to any configuration can be carried out without recourse to specially handed mechanical components. Some new hoses will be required, refer to hydraulic installation pages in the parts list for specific requirements.

It is stressed that conversion is a major re-build and not an in-field adjustment. A workshop with overhead lifting tackle is required.

Before commencing drain the hydraulic system and empty the reservoir.

#### Important points

The pump\gearbox assembly is horizontally mounted. For left front and rear right builds it is mounted with the pump away from the tank.

For right front and rear left builds it is mounted with the pump towards the tank.

The hydraulic hoses to the flail motor and the angle ram are always routed up the front face of the main arm crossed over at the pivot and down the rear face of the dipper regardless of machine build.

The flail head is despatched with the motor mounted inboard. If converting right to left or vice versa and if an inboard mounted motor is an important operational requirement it will be necessary to rebuild the flail head with the motor mounted at the opposite end.

# MAINTENANCE

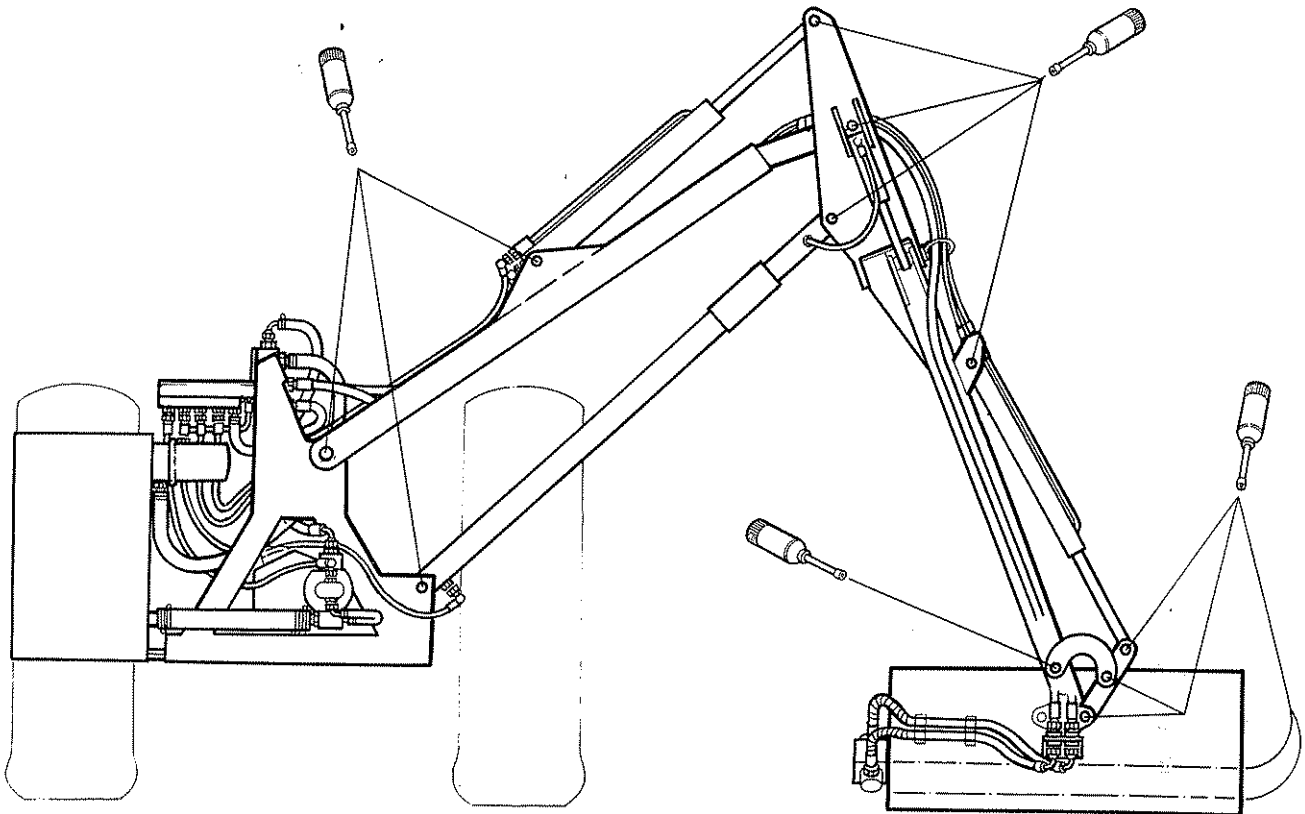

## LUBRICATION

### General

Refer to the lubrication diagram and grease daily all points shown.

### Power take-off shaft

The PTO shaft should be regularly examined to ensure that it is in good condition together with the guards. The universal joints should be greased very sparingly i.e. one shot weekly.

**Note:** Overgreasing a universal joint will blow-out the cork or neoprene sealing rings that exclude the dirt from the needle bearings inside.

The two halves of the plastic guard should be checked daily to ensure that they can spin freely on the shaft. The nylon slip rings which support the guard on the drive shaft should be lightly greased at weekly intervals.

The telescopic drive shaft should be similarly separated and grease applied to the internal shaft at approximately 100 hour intervals.

## **HYDRAULIC SYSTEM**

### **Oil supply**

Check daily the oil level in the reservoir.

No fixed time period can be quoted for oil changes as operating conditions and maintenance standards vary so widely. Although the oil does not wear out, it does eventually break down through contamination, oxidation and condensation. Continual operation of the machine beyond its rated capacity to almost the stall point of the rotor can cause overheating which produces insoluble gums, sludge, varnish and acids. Overheated oil tends to give a sluggish performance and causes earlier failure of seals and 'O' rings. Burnt and scorched oil odours and the oil darkening and thickening are all signs of oxidation and indicate the oil should be changed.

Moisture which results from condensation can become entrapped in the oil and cannot be removed by filtration so that contamination is a progressive factor.

Contamination can be reduced by:

- 1) Carrying all hydraulic servicing in clean, dust-free surroundings
- II) Cleaning off around the reservoir cap before removal, and keeping that area clean.
- III) Using clean containers when replenishing the system
- iv) Regular servicing of the filtration system.

### **Filtration Maintenance**

The machine is protected by a 125 micron suction strainer and a low pressure 10 micron full flow return line filter.

#### **I) Suction Strainer**

The strainer is fixed in position within the reservoir. Should symptoms of pump cavitation or spongy intermittent operation occur the tank must be drained and flushed out with a suitable cleaning agent eg. clean diesel oil.

#### **II) Return Line Filter**

The element should be changed after the first 50 hours and thereafter at 500 hour intervals. It is important to note hours worked as if the filter becomes blocked an internal by-pass within the canister will operate and no symptoms of filter malfunction will occur to jog your memory.

## **FLOAT KIT ACCUMULATOR TEST**

If a leak of Nitrogen is suspected a test with soapy water around the valve thread and core area should be carried out. A replacement charge valve assembly can be fitted after the accumulator has been fully discharged. It is essential that this work is carried out by the dealer or distributor who must have the facilities for recharging. The accumulator can be removed for this purpose. If oil is leaking from the area of the charge valve then the internal butyl bag is damaged and the accumulator is scrap.

## HYDRAULIC PUMPS

All pumps are clockwise rotation. No routine maintenance is necessary other than a periodical check for tightness of the mounting bolts and a visual check for oil leakage especially around the pump supply and pressure unions. Where two hose clips are used on the pump supply hose, their worm drive barrels should be placed opposite each other at 180 degrees. When fitted with tandem pump assembly do not attempt to operate the armhead rams without the 5/8 BSP flail hoses being interconnected. The tandem pumps share a common seal drain and both circuits must be intact before the pumps are run.

Pump servicing is limited to replacing seals, gaskets and 'O' rings. Servicing should take place under clean dust free conditions. Pumps should be thoroughly washed and their end plates and body lightly identified with scribe marks to ensure correct re-assembly.

When re-assembling, lubricate all components with clean oil and tighten down the securing bolts in a diagonal sequence to pull the pumps squarely together, finally tightening to a torque load of :-

4 - 5 Kgm (30-37 lbs\ft) M10 Setscrew

2 1/2 -3 KGM (18-22 LBS\FT) M8 Setscrew

Check for freedom of rotation. The pumps should turn freely under a hand load applied on a 6" radius arm. If tight, the lobe seals and/or backing washers have been trapped and the unit must be dismantled to rectify this.

After installation, the serviced pumps should be run for several minutes under a 'no load' condition before load is gradually applied. During this time frequent checks should be made of the pump casing temperature. An excessive temperature rise will indicate that the pump has been assembled incorrectly.

Generally it is unwise to replace major components since they have to be matched in sets. Unless this is done the pump will be inefficient, resulting in overheating and power loss. No detailed parts breakdown is shown, but factory reconditioned units are available within our service exchange scheme.

## FLAILHEAD

Frequently inspect the rotor assembly for damaged or missing flails. Bolts and nuts securing the flails to the rotor should be regularly checked and kept tight. The correct torque setting for these locknuts is 135 Nm (100 lbf\ft.) Use only the correct flail bolt and locking nut. Check the flail pivot bushes for possible damage or wear. They do not require oil.

Do not attempt to run the rotor with flails missing. Im-balance will cause severe vibration and can rapidly damage the rotor shaft bearings. As an emergency measure if a flail is broken off or lost, remove another on the opposite site of the rotor to retain balance. Always replace flails in opposite pairs and never match up a new flail with a re-sharpened one which will of course be lighter.

Blunt flails absorb a lot of power and leave an untidy finish to the work. They should be sharpened on a grindstone or with a portable grinder periodically. Wear protective gear when sharpening flails.

Ensure that the bearing housings and hydraulic mounting nuts and bolts are kept tight. They should be checked during servicing.

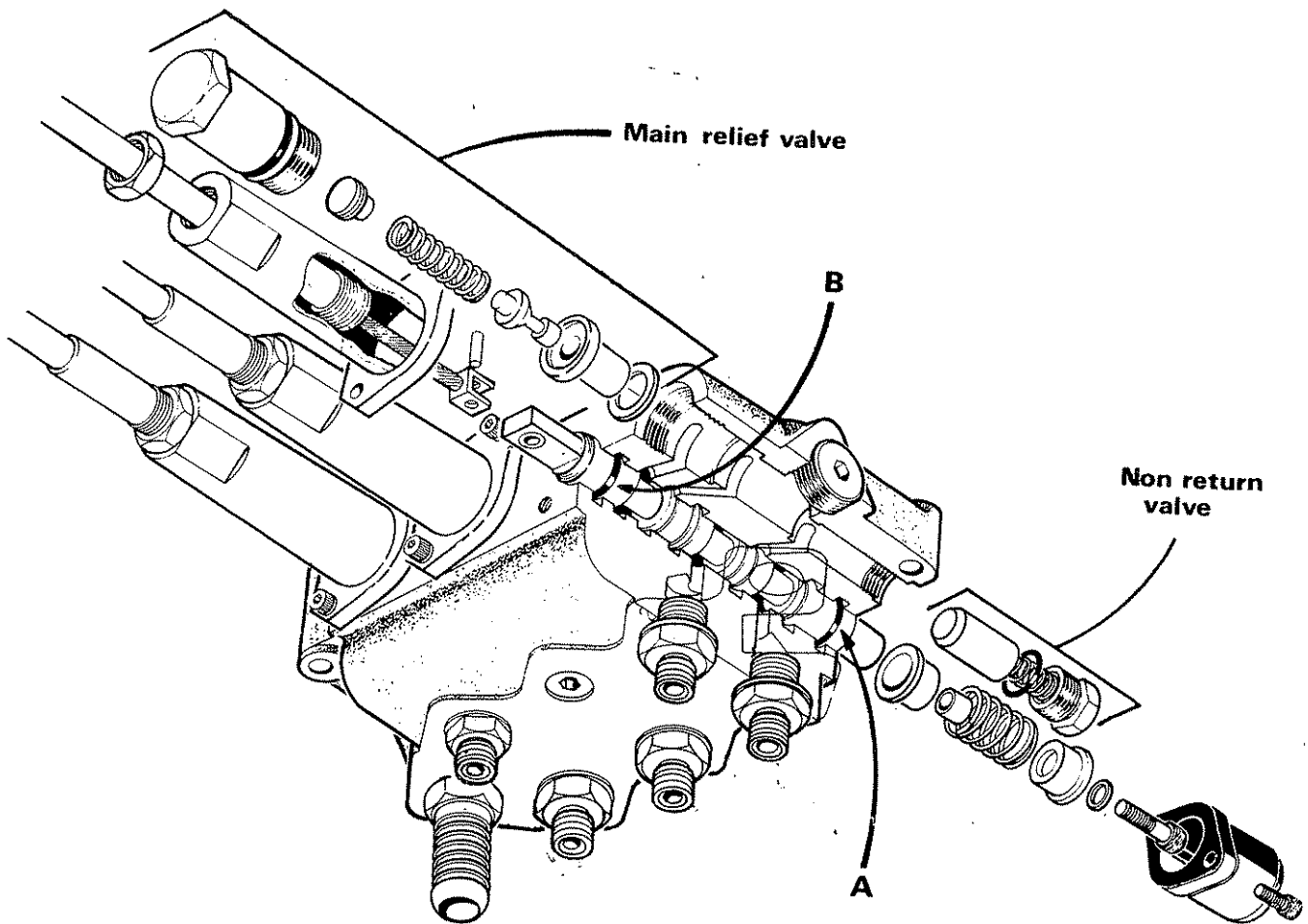

## CABLE OPERATED ARMHEAD CONTROL VALVE

Replacing damaged or worn spool 'O' rings

Release the locknut located on the cable at the back of the sleeve.

Remove the two allen headed capscrews that secure the sleeve to the valve block and screw the sleeve back down the threaded portion of the cable to reveal the clevis pin which is then withdrawn from the end of the spool. Take care not to lose the roller in the eye of the spool end.

Remove the spring cover at the opposite end of the spool and remove the setscrew to release the return spring assembly.

Pull the spool through the block from the cable end until 'O' ring marked 'A' is accessible. Remove the 'O' ring from its groove using a smooth edged hook.

Completely remove the spool from the block out of the return spring end.

Remove 'O' ring marked 'B' and refit a new 'O' ring.

Lightly oil the spool and replace it in the block from the return spring end pushing it through just far enough to clear 'O' ring groove at 'A'.

Fit new 'O' ring in groove 'A'.

Push the spool back through from the cable end far enough to re-assemble the return spring assembly and cover.

Replace the clevis pin in the spindle eye and re-assemble the sleeve. Adjustment of the threaded section being correct when the handle on the control box is in a vertical position. Re-tighten the locknut.

Note: Owing to the sharp edges in the design of the spool, failure to follow the above procedure could result in damage to the new 'O' rings resulting in external leakage.

The spools are selectively assembled, matched with their mating bores in the block and should not be interchanged.

## **Main Relief Valve**

The main relief valve is pressure set at the factory to 1800 PSI (125 Bar) and is non adjustable. A sticking relief valve will probably cause overheating and/or loss of power. If this is suspected it should be dismantled and examined for dirt and damage. Undo the large hexagon housing, the relief valve spring, needle and seat can now be withdrawn. If difficulty is experienced in extracting the seat remove the non-return valve at the opposite end of the gallery and drive out with a soft brass drift. Take care not to damage the copper sealing washer positioned between the seat and the locating shoulder in the block.

Blow out the valve with compressed air and examine the components for damage. These components are specially hardened steel and should only display a seating witness - any further damage will require the complete valve to be replaced.

### **CAUTION**

Under no circumstances be tempted to add shims into this valve in a misguided attempt to increase the power of the machine. This could damage the tractor, and may cause personal injury.

### **Non Return Valve**

The non-return valve prevents the feed back of oil from the service ports to the pump. It is unlikely to need attention but if removed for cleaning a new 'O' ring should be fitted.

## **CABLES**

The cables operate on a push/pull system with the spool centering springs always returning the spool to the neutral position when the handle is released.

Care should be taken during installation and operation to ensure that the cables are not trapped or kinked. Any abrasion or damage to the outer casing should be sealed with plastic insulation tape to avoid moisture penetrating.

No routine adjustment of the cables are necessary as they do not stretch. The threaded collar is correctly adjusted when the lever is in a vertical position in its housing allowing an equal amount of travel in either direction.

**CAUTION** On no account should any attempt be made to lubricate the cables which are assembled with a special lubricant during manufacture.

**NOTE:** Take care to ascertain the correct cable connections on both the control unit and the valve in the event of cable replacement.



# HYDRAULIC RAMS

## Ram seal replacement - general information

Whenever possible the ram should be removed from the machine and cleaned off before dismantling on a clean work bench.

When using a bench vice do not apply excessive pressure to the ram cylinder- use soft metal jaws when grasping the ram rod.

Remove scores and nicks on the ram rod by using a fine oil stone. Do not use a file or emery cloth.

Lubricate all new seals thoroughly prior to assembly.

## Angling ram

### Replacing seals

Unscrew the gland and withdraw the complete rod assembly. Remove piston locking nut, slide the piston and gland housing of the rod.

Lubricate all new seals prior to assembly.

Replace the gland seals ensuring they are positioned in the same location from which they were removed. Carefully place the gland housing complete with seals back on the rod.

Separate the piston halves and discard rod seals. Rebuild the piston onto the rod fitting a new piston rod O' ring.

The piston seals can be replaced in conjunction with the above operation or alternatively, gently prised into position after the piston and locking nut are reassembled.

Refit the piston locking nut using 'Permabond A113' or a similar medium strength thread locking compound.

Reassemble the complete rod into the ram cylinder. Screw in gland housing and tighten.

## Reach ram

### Renewing gland seals

Unscrew the gland nut using a C spanner and withdraw the complete rod assembly. Remove the piston using a peg spanner and slide off the gland housing.

Replace seals as necessary. Ensure that seals are replaced in the same attitude and in the same position from which they came.

### Refitting a piston

The piston is locked onto the rod with a medium strength thread locking fluid such as "Permabond A113", "Loctite Nutloc 242", Dunlop Nutloc SA5110, Tru lock Nutgrade 375 or Hermetite Torqueseal M. The threads must be cleaned with a suitable solvent to remove oil and thoroughly dried before applying a complete film of locking fluid to the rod threads. The piston should be screwed on, tightened firmly and left for 30 minutes before filling with oil and 1 hour before pressurising.

## **Renewing piston seals**

To renew the piston seals it is not necessary to remove the piston from the rod.

Remove split members of the piston seal and then, using a soft lever which will not scratch the piston lift the remaining seal components from the piston. Replace with new seals in the reverse order.

## **Lift ram**

The lift ram is a single acting ram.

### **Renewing seals**

Using a 'C' spanner unscrew the cylinder head.

Withdraw the head and ram rod from the barrel and separate.

Renew all seals including the rod wear ring taking care to replace the new seals in the same position and attitude from where they came.

Replace the rod and carefully slide the cylinder head complete with its seals over the nose of the rod. Screw firmly into place following the thread cleaning and locking procedure previously described in para 'Re-fitting a piston' on page.28

## **Break away ram**

The breakaway ram is a single acting ram.

### **Replacing seals**

The procedure for dismantling, replacing seals and re-building is similar to the lift ram except that in this case the whole ram barrel unscrews, there is no wear ring on the ram rod, and the 'O' ring is located on the nose of the ram base.

### **Relief valve**

The relief valve situated in the base of the ram is pre set to 900 PSI (63 Bar)

Its function is to raise pressure in the breakaway ram thus ensuring an adequate breakaway resistance when an obstacle is encountered.

The force required to cause the flail head to breakback will vary according to arm position. A lighter than usual breakaway force for any given working position would indicate a leaking relief seat.

Examine for dirt or damage to the seat on either the union or the relief valve. Damage will require the replacement of the component. Do not attempt to dismantle the relief valve and on replacing take care to fit the spring beneath the relief valve on re assembly.

## **RESTRICTORS**

Restrictor unions which are identified by code letters are calibrated for correct speed of operation. The restricted hole should not be enlarged or the unions position interchanged.

# ROTOR CONTROL VALVE\RELIEF VALVE

## Relief valve

The relief valve within the block is pre-calibrated to give setting of a 3000 P.S.I. (210 Bar). No servicing should be required other than cleaning and examining for damage should a malfunction occur. Evidence of damage will require a new component.

## Replacing worn or damaged 'O' rings

The cable and spring centering mechanism must be removed. The brass bobbin at either end can be extracted and the 'O' rings can be removed from their locations using a soft hooked implement.

Replace the 'O' rings carefully feeding them over the spool ends.

Replace the brass bobbins and re assemble the spring centering mechanism and cable to the valve.

## P.T.O. GEARBOX

The gearbox is rigidly bolted on to the main frame and has a filler plug. Oil level is correct when level with the lip of the filler plug aperture. The gearbox oil should be changed every year or at 600 hour intervals; whichever occurs first. The capacity of the gearbox is 700 millilitres ( 1 and a quarter pints) of EP 90 gear oil.

## HYDRAULIC MOTOR

Servicing of the hydraulic motor should be limited to replacing seals, gaskets and O rings. Components of the motor are matched to close tolerances and are therefore not replaceable as individual parts.

The torque setting of the cap screws is 6-7 Kgm (40-47 lbs\ft)

To remove the drive coupling from the shaft use a tool of the sprocket type to remove it. Do not attempt to remove the coupling by hammering or leverage as this will damage the motor internally.

## Replacing shaft seals

The double shaft seal assembly must be assembled with the 7 m.m. wide single lip seal fitted first with the 1 m.m. thick lip support washer on top. The back of the double lip seal should be filled with a light grease before fitting with the wiper lip outermost.

The seal kit, Part No. 86 99 216 is a universal Cassapa motor sealkit. It may contain more seals than are necessary; care must be taken in selecting the correct seal to use.

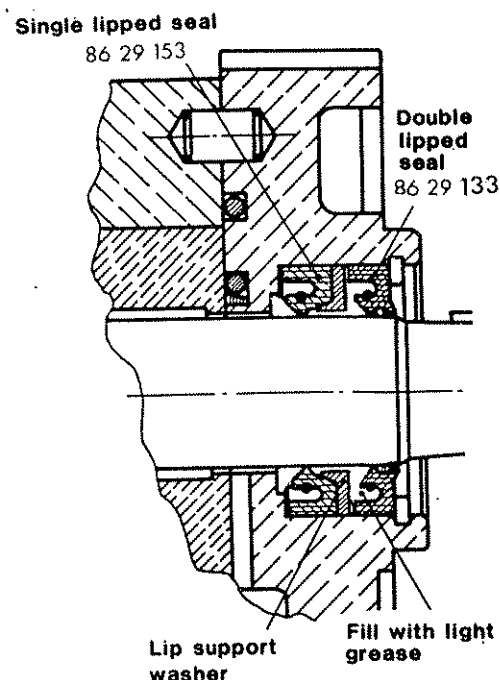

## **HYDRAULIC HOSES**

The condition of all hoses should be carefully checked during routine service of the machine. Hoses that have been chafed or damaged on their outer casing should be securely wrapped with waterproof adhesive tape to stop the metal braid from rusting. Hoses that have suffered damage to the metal braid should be changed at the earliest opportunity.

### **Hose replacement**

- a. Replace one hose at a time to avoid the risk of wrong connections
- b. When the hose is screwed to an additional fitting or union, use a second spanner on the union to avoid breaking seals.
- c. Do not use jointing compound on the threads.
- d. Avoid twisting the hose. Adjust the hose line to ensure freedom from rubbing or trapping before tightening hose end connections.

Before changing hoses study the installation these are carefully calculated to prevent hose damage during operation. Always replace hoses in exactly the same manner.

Two hose clips are provided at either end of the large bore suction and return hoses. These should be positioned so that their worm drive barrels are opposed at 180 degrees to reduce the possibility of air entering the system.

### **Hose warranty**

Warranty is limited to replacement of hoses which have failed due to faulty materials or manufacture. Warranty will not be considered on hoses that have suffered damage by abrasion, cuts or being pinched or trapped while in work. Neither will a claim be considered where a hose end has been damaged by a blow or where the threads or unions have been damaged by overtightening.

# HOSE CONNECTIONS

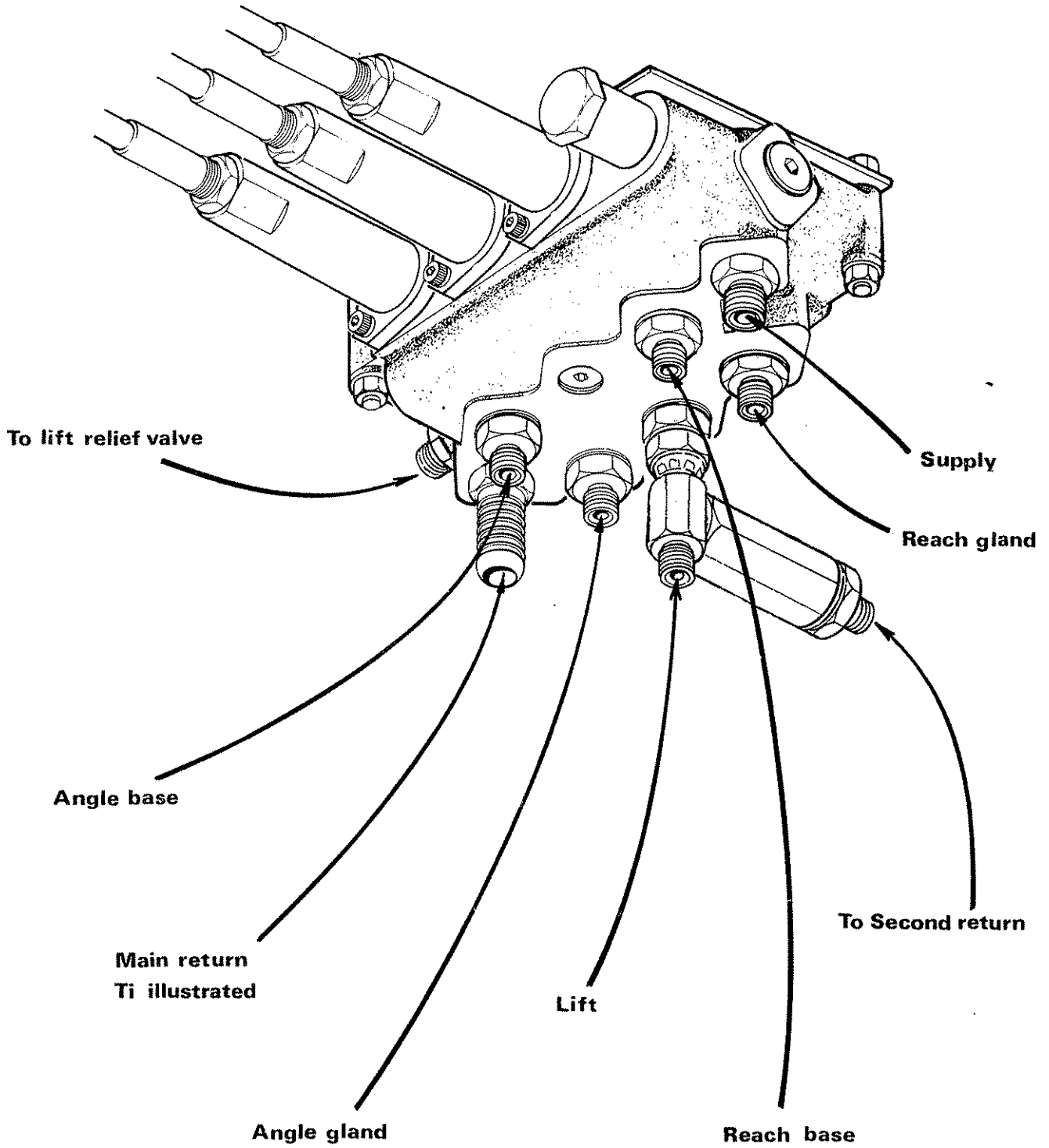



*For best performance ...*

## **USE ONLY GENUINE McCONEL SERVICE PARTS**

*To be assured of the latest design improvements purchase your  
'Genuine Replacements' from the 'Original Equipment Manufacturer'*

### **McCONEL LIMITED**

*Through your local Dealer or Stockist*

**Always quote:**

- ***Machine Type***
- ***Serial Number***
- ***Part Number***

*Design improvements may alter some of the parts listed in this manual –  
the latest part will always be supplied when it is interchangeable with an earlier one.*

Model

**FRAME & STABILISER**

**McCONEL**

Temeside Works, Ludlow,  
Shropshire, SY8 1JL, England.  
Telephone: (0584) 3131.  
Telex 35313. Facsimile: (0584) 6463.

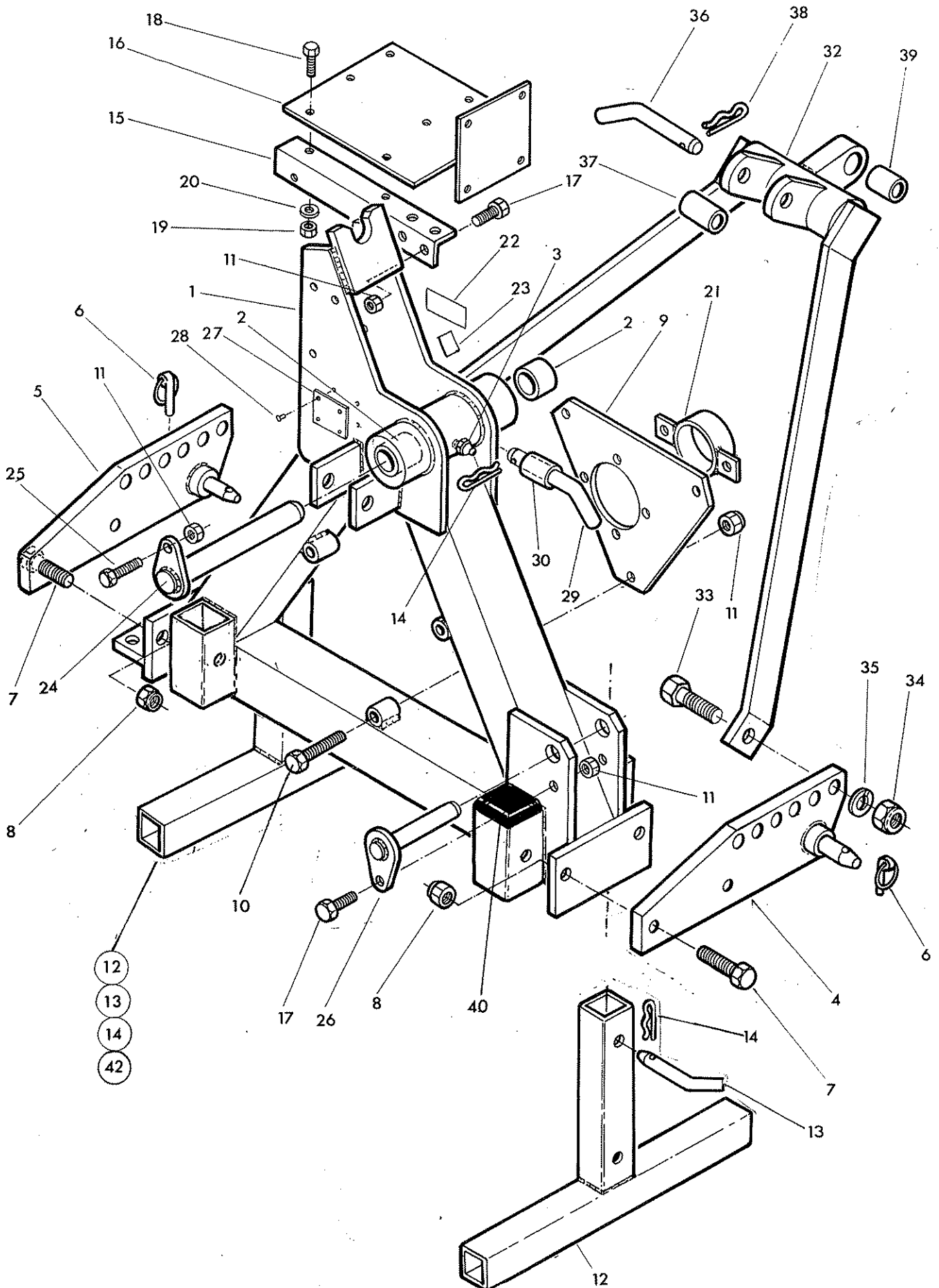



Ref.	Part	Qty.	Description
<b>MAIN FRAME, STABILISER, ETC</b>			
1	71-91-261	1	Main frame
2	72-13-023	2	Bush
3	09-01-121	1	Greaser
4	71-91-264	1	Linkage plate
5	71-91-263	1	Linkage plate
6	04-31-217	2	Linch pin
7	92-13-107	4	Bolt
8	91-43-007	4	Self locking nut
9	71-91-052	1	Gearbox mounting plate
10	92-13-125	3	Bolt
11	91-43-005	7	Self locking nut
12	71-91-058	2	Stand leg
13	71-92-023	2	Leg pin
14	04-31-105	3	Spring cotter
15	71-91-076	1	Valve mounting stalk
16	71-91-079	1	Valve mounting plate
17	92-13-055	3	Bolt
18	93-13-044	2	Setscrew
19	91-13-004	2	Nut
20	91-00-204	2	Spring washer
21	71-91-075	1	P.T.O. guard mounting
22	71-11-038	1	Drive shaft guard
23	09-04-114	1	Hose clip
24	71-91-033	1	Main arm pivot pin
25	92-13-065	1	Bolt
26	71-91-039	1	Lift ram base pin
27	71-91-097	1	Serial No. plate
28	71-03-230	4	Pop rivet
29	71-92-026	1	Top link pin
30	14-67-063	1	Sleeve
31	71-14-289	1	Drive shaft assembly -not illustrated
	71-91-323		<b>STABILISER KIT comprising:-</b>
32	71-91-265	1	Stabiliser
33	93-13-118	2	Setscrew
34	91-13-008	2	Nut
35	91-00-208	2	Spring washer
36	71-92-026	1	Top link pin
37	14-67-063	1	Cat. II sleeve
38	04-31-105	1	Spring cotter
39	71-11-006	1	Sleeve
40	71-35-295	1	Sticker "Tighten check chains"
41	71-05-130	1	Sticker "Read instruction book first
42	71-91-108	2	Stand leg insert



Model

ARMS

# McCONEL

Temeside Works, Ludlow,  
Shropshire, SY8 1JL, England.  
Telephone: (0584) 3131.  
Telex 35313. Facsimile: (0584) 6463.

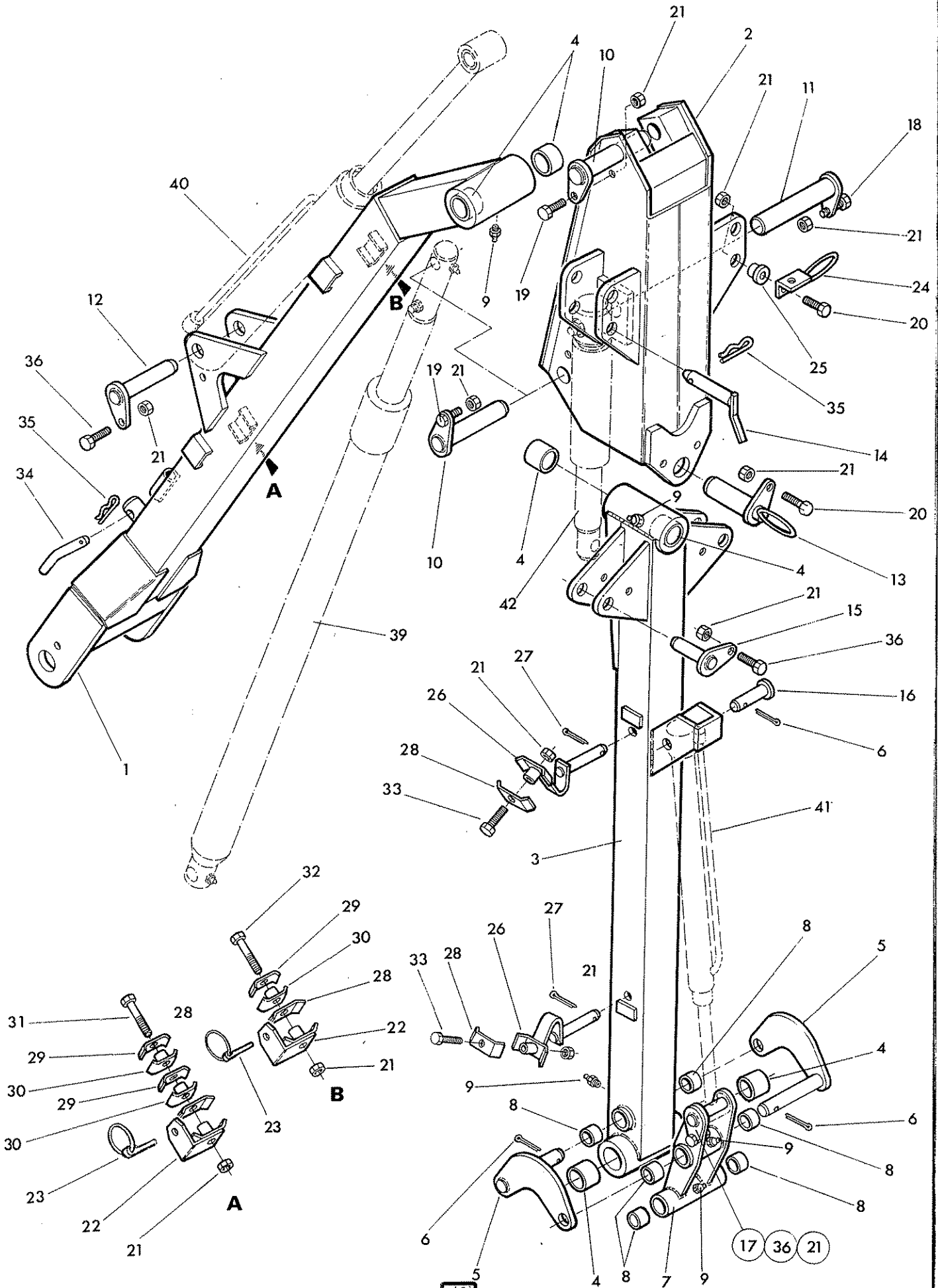

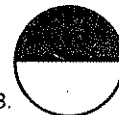

Ref.	Part No.	Qty.	Description
<b>ARMS</b>			
1	71-91-267	1	Main arm
2	71-91-268	1	Dipper arm - upper
3	71-91-271	1	Dipper arm - outer
4	72-13-023	6	Bush
5	71-91-282	2	Radius arm
6	95-01-083	3	Split pin
7	71-91-281	1	Slave link
8	71-01-083	6	Bush
9	09-01-121	6	Greaser
10	71-91-040	2	Pivot pin - lift and reach rod
11	71-91-034	1	Pivot pin - dipper
12	71-91-038	1	Pivot pin - reach base
13	71-91-310	1	Pivot pin - dipper/breakaway
14	71-91-036	1	Pivot pin - Breakaway base
15	71-91-037	1	Pivot pin - breakaway rod
16	71-91-041	1	Pivot pin - angle base
17	71-91-042	1	Pivot pin - angle rod
18	92-13-075	1	Bolt
19	93-13-045	1	Setscrew
20	92-13-065	2	Bolt
21	91-43-005	12	Self locking nut
22	71-91-028	2	Hose bracket
23	04-31-217	2	Linch pin
24	71-91-305	1	Hose bracket
25	71-91-029	1	Pivot bush - hose bracket
26	71-91-311	2	Hose support bracket -dipper
27	95-01-325	2	Split pin
28	71-91-102	4	Hose clamp large
29	71-14-075	3	Hose clamp - small-upper
30	71-14-076	3	Hose clamp-small -lower
31	92-13-185	1	Bolt
32	92-13-145	1	Bolt
33	92-13-105	2	Bolt
34	71-91-057	1	Armhead lock pin
35	04-31-105	2	Spring cotter
36	92-13-055	3	Bolt
37*	12-90-295	1	"Power Arm" sticker }not-
38*	12-90-026	1	"91 Sticker" }illus

\*Assembly.Stickers are not illustrated as position varies depending upon machine build.

39	71-91-068	1	Lift ram -ref only-see page 70
40	71-91-070	1	Reach ram -ref only-see page 71
41	71-91-072	1	Angling ram - ref only- see page 72
42	71-91-297	1	Breakaway ram - ref only- see page 73

HYDRAULIC TANK



McCOMEL

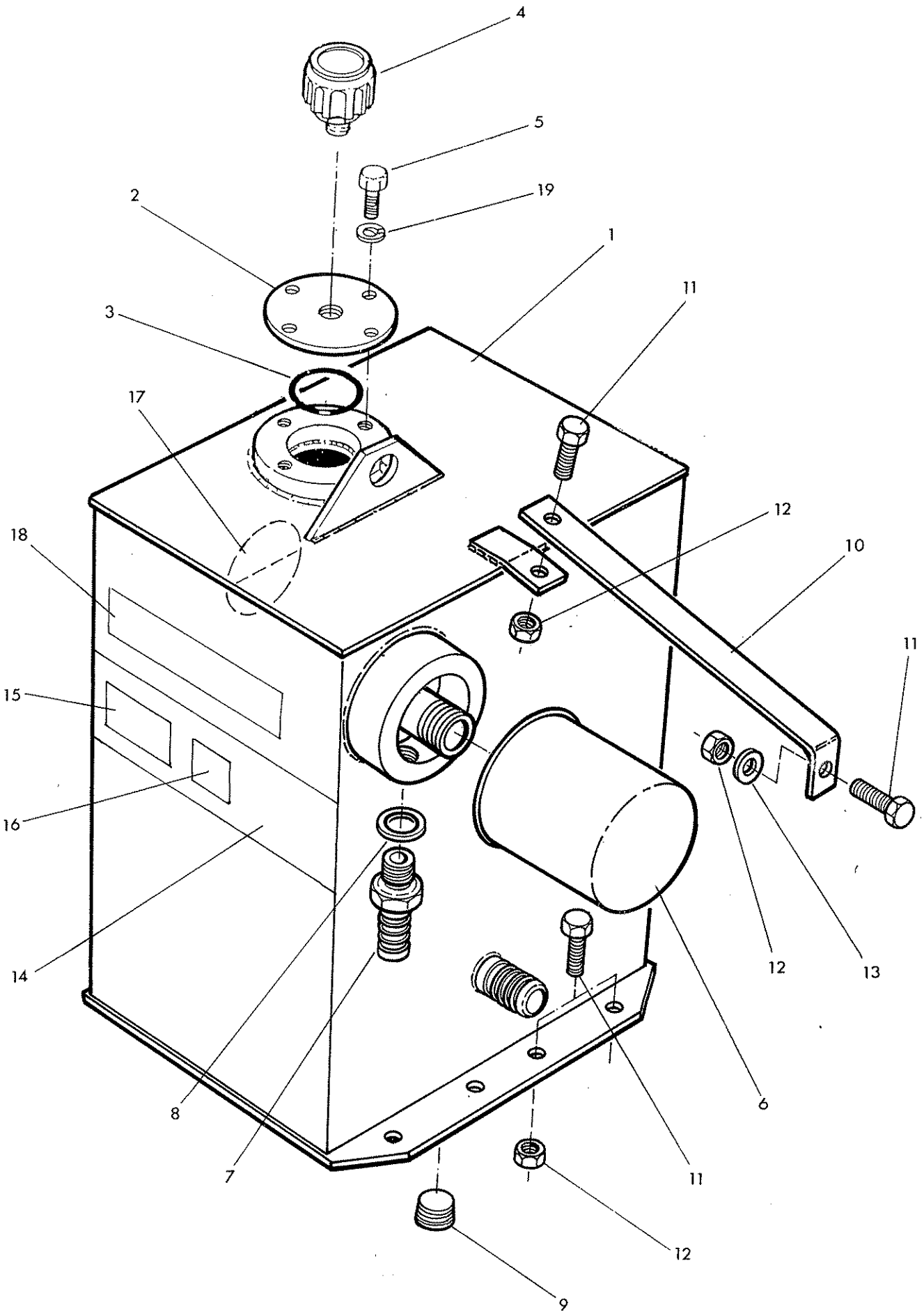



Ref	Part No	Qty	Description
	71-91-304		OIL TANK ASSEMBLY
1	71-91-309	1	Oil tank
2	71-92-062	1	Cover
3	86-00-051	1	'O' ring
4	84-01-063	1	Breather
5	93-13-054	4	Set screw
6	84-01-041	1	Filter element
7	85-81-246	1	Adaptor
8	86-50-106	1	Bonded seal
9	85-81-203	1	Drain plug
10	71-91-074	1	Tank stap
11	93-13-076	4	Set screw
12	91-43-006	4	Self locking nut
13	91-00-106	1	Plain washer
14	12-90-330	1	Stripe sticker
15	12-90-329	1	PA91 sticker
16	12-90-024	1	Si sticker
	12-90-025	1	Ti sticker
17	12-90-296	1	Roundel
18	12-90-253	1	'McConnel' sticker
19	91-00-204	4	Spring washer

\*Assembly note-

Item . to be assembled using P.T.F.E. tape, or 'Permabond A121'

Model

# McCONEL

Temeside Works, Ludlow,  
Shropshire, SY8 1JL, England.  
Telephone: (0584) 3131.  
Telex 35313. Facsimile: (0584) 6463.



## FLAIL HEAD

Sheet 1

L.Hand illustrated

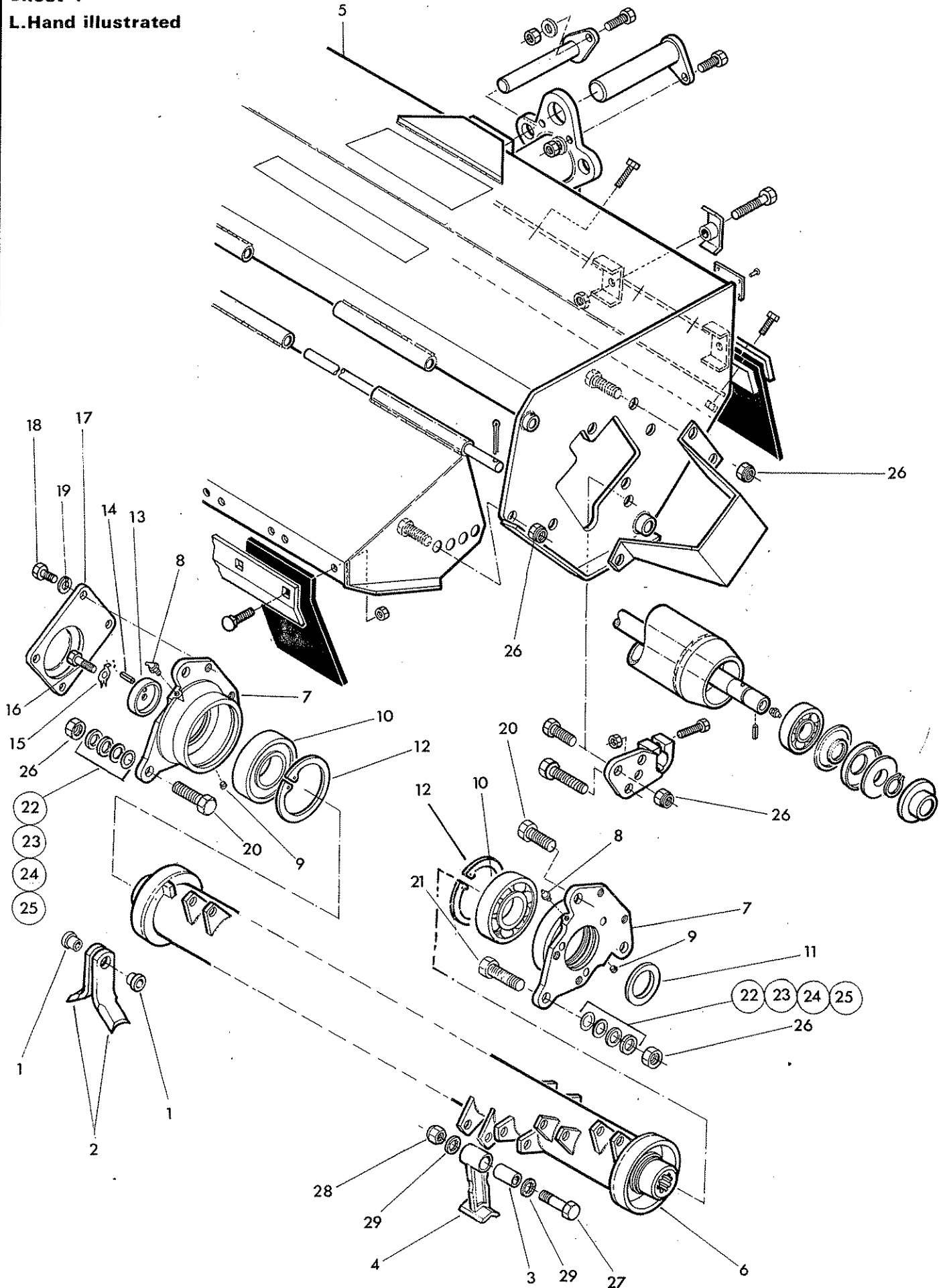



## FLAIL HEAD ASSEMBLIES

Ref.	Part No.	Qty.	Description
	71-91-251		FLAIL HEAD LEFT HAND EQUIPPED WITH PRESSED FLAILS
	71-91-250		FLAIL HEAD R HAND EQUIPPED WITH PRESSED FLAILS
1	71-91-095	40	Flail bush
2	71-90-315	40	Flail - pressed
	71-91-253		FLAIL HEAD LEFT HAND EQUIPPED WITH CAST FLAILS
	71-91-252		FLAIL HEAD RIGHT HAND EQUIPPED WITH CAST FLAILS
3	71-91-054	20	Flail bush
4	71-91-320	20	Flail - cast

Parts lists for left or right hand flails are identical for either pressed or cast flail builds the difference being in the assembly.

The 'hand' of a flail head is determined by which end of the rotor the motor is mounted on when viewed from the rear.

Machines are despatched as standard with the motor mounted on the inboard end of the rotor therefore it should be noted that a left hand flail head is needed if it is required to cut on the right hand side of the tractor.

The remaining items are common to all flail assemblies

5	71-91-272	1	Flail casing
6	71-91-314	1	Rotor
7	71-90-261	2	Bearing housing
8	09-01-124	2	Greaser
9	85-82-041	2	Plug
10	06-00-018	2	Ball bearing
11	71-90-015	1	Motor locating washer
12	71-90-022	2	Internal circlip
13	71-90-025	1	Clamp washer
14	04-21-608	1	Spring dowel
15	71-90-024	1	Tabwasher
16	93-13-076	1	Setscrew
17	71-90-292	1	Cover plate
18	93-13-045	4	Setscrew
19	91-00-205	4	Spring washer
20	03-11-126	5	Setscrew
21	03-11-146	1	Setscrew
22	81-21-044	as req.	Shim .24
23	81-21-043	" "	Shim 0.16
24	71-91-099	" "	Shim 2.5mm
25	71-91-098	" "	Shim 1.5mm
26	01-41-006	14	Self locking nut
27	71-91-109	20	Bolt
28	01-41-005	20	Self locking nut
29	01-00-305	20	Internal shakeproof washer



Sheet 2  
L. Hand illustrated

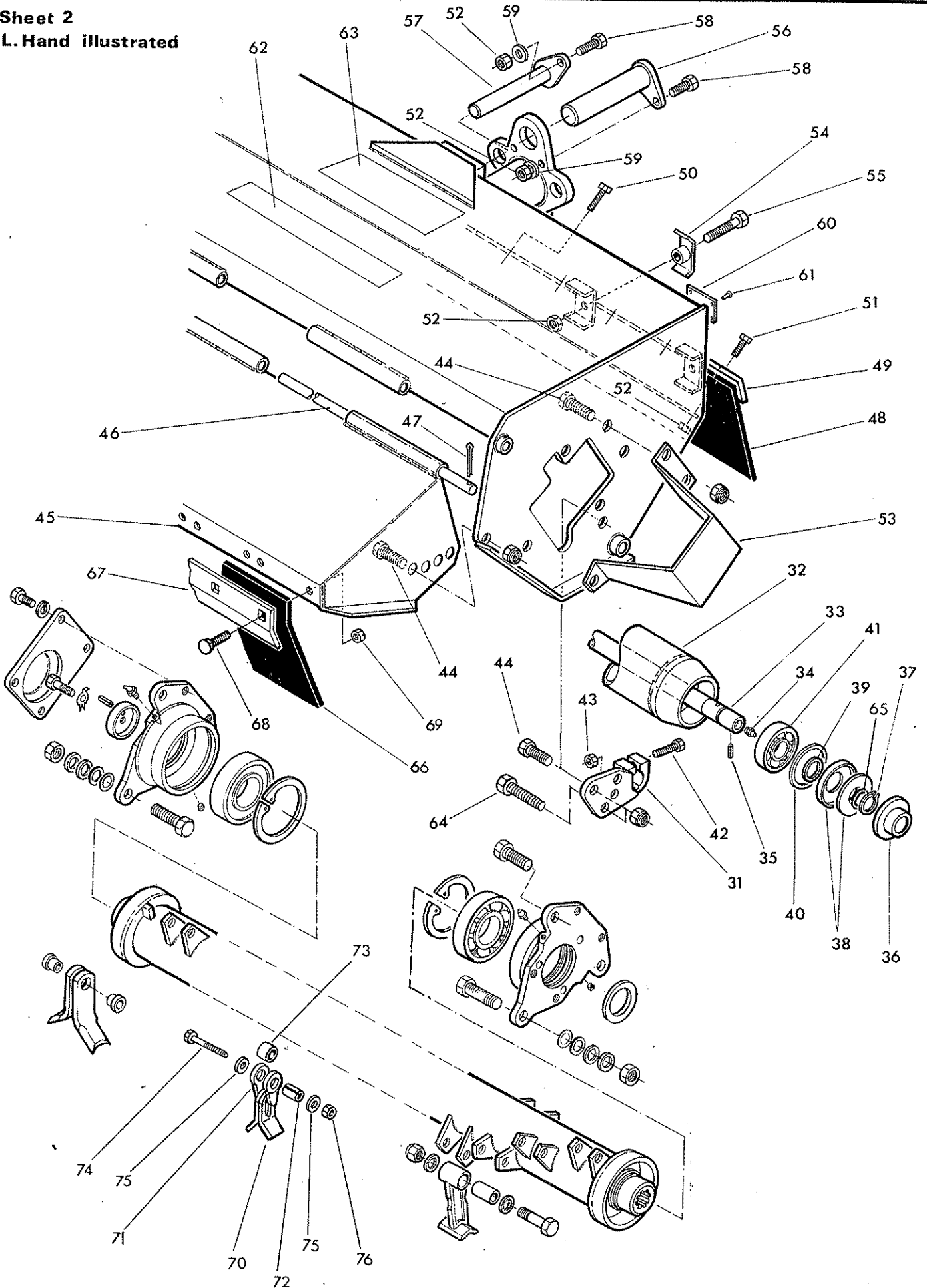

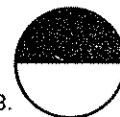

Ref. Part No. Qty. Description

71-91-250

to

71-91-253

FLAIL HEAD ASSEMBLIES

The following items are common to all flail head assemblies

30	71-91-288	1	Roller bracket - Right hand -not illus
31	71-91-287	1	Roller bracket - Left hand
32	71-91-284	1	Roller
33	71-91-286	1	Roller axle
34	09-01-121	2	Greaser
35	04-25-408	1	Spring dowel
36	71-91-285	2	Roller spacer
37	04-01-225	2	External circlip
38	71-91-091	2	Sealing washer set
39	71-91-092	2	Spacer washer - small
40	71-91-093	2	Spacer washer - inner
41	06-00-088	2	Ball bearing
42	02-11-183	2	Bolt
43	01-41-003	2	Self locking nut
44	03-11-106	6	Setscrew
45	71-91-279	1	Front hood
46	71-91-094	1	Hood pivot pin
47	95-01-406	1	Split pin
48	71-91-300	1	Rear flap
49	71-91-319	1	Clamp strip
50	93-13-075	1	Setscrew
51	93-13-055	8	Setscrew
52	91-43-005	13	Self locking nut
53	71-91-283	1	Motor cover
54	71-91-096	2	Hose clamp
55	92-13-095	2	Bolt
56	71-91-034	1	Head pivot pin
57	71-91-043	1	Slave link pin
58	93-13-075	2	Setscrew
59	91-00-105	2	Plain washer
60	73-14-087	1	Serial No. plate
61	71-03-230	4	Pop rivet
62	12-90-255	1	Sticker "McConnel"
63	12-90-297	1	Sticker "Instructions"
64	03-11-146	2	Setscrew
65	71-91-107	as reqd.	Roller Shim

OPTIONAL EXTRA

	71-91-321		FRONT FLAP KIT compr:-
66	71-90-035	7	Front flap
67	71-90-350	1	Clamp strip
68	92-93-054	14	Bolt - cup sq.
69	91-43-004	14	Self locking nut

71-91-254

FLAIL HEAD RIGHT HAND WITH SHACKLE

FLAILS

71-91-255

FLAIL HEAD LEFT HAND WITH SHACKLE

FLAILS

The parts lists are identical to above with the following exceptions

70	71-11-022	40	Flail
71	71-91-333	20	Shackle
72	04-28-355	20	Roll pin
73	71-91-113	20	Sleeve
74	02-11-222	20	Bolt
75	01-00-102	40	Plain washer
76	01-41-002	20	Self locking nut



Model

**CONTROL MOUNTING  
PILLAR**

**McCONEL**

Temeside Works, Ludlow,  
Shropshire, SY8 1JL, England.  
Telephone: (0584) 3131.  
Telex 35313. Facsimile: (0584) 6463.

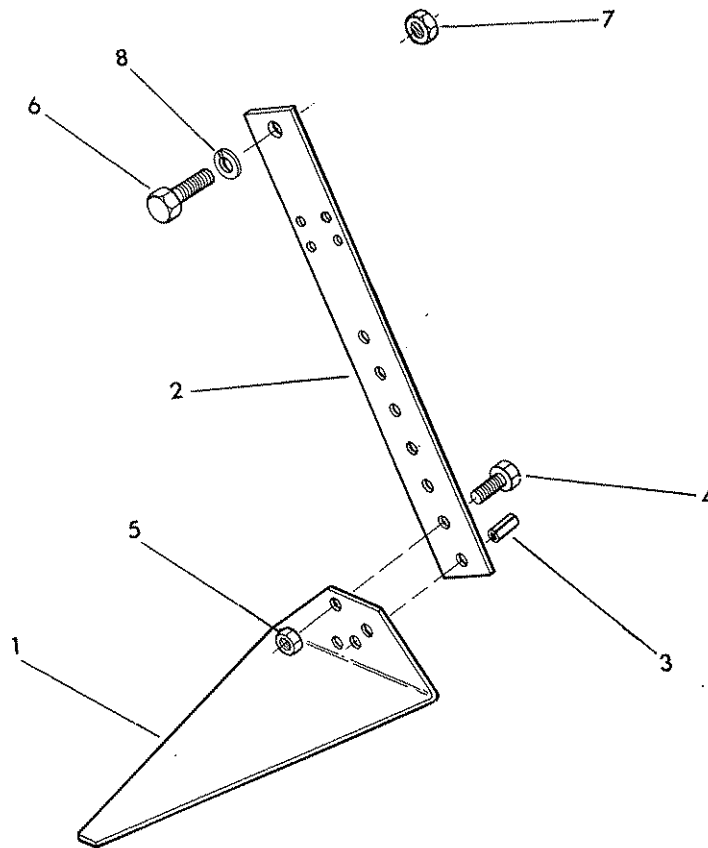

Ref.	Part No.	Qty.	Description
	<b>71-09-319</b>		<b>CONTROL MOUNTING ASSEMBLY</b>
1	71-09-320	1	Sandwich plate
2	71-09-146	1	Pillar including spring dowel
3	04-22-816	1	Spring dowel
4	93-13-066	1	Setscrew
5	91-13-006	1	Nut
6	93-11-086	1	Setscrew
7	01-11-006	1	Nut
8	01-00-206	1	Spring washer

Model

**CAB GUARD**

# McCONEL

Temeside Works, Ludlow,  
Shropshire, SY8 1JL, England.  
Telephone: (0584) 3131.  
Telex 35313. Facsimile: (0584) 6463.

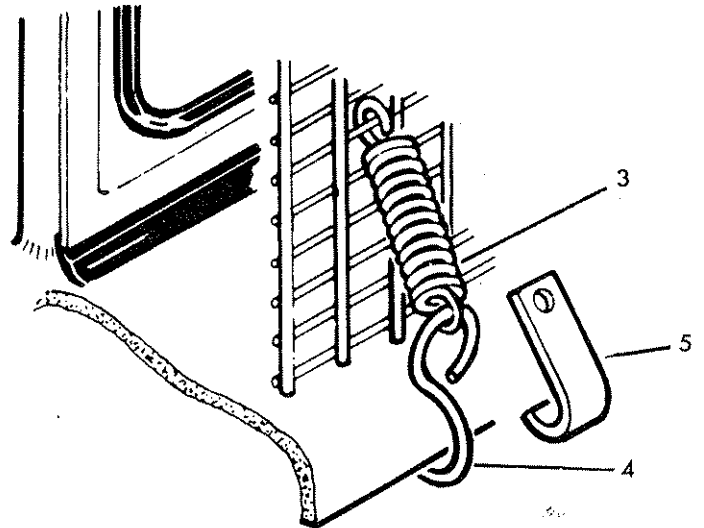
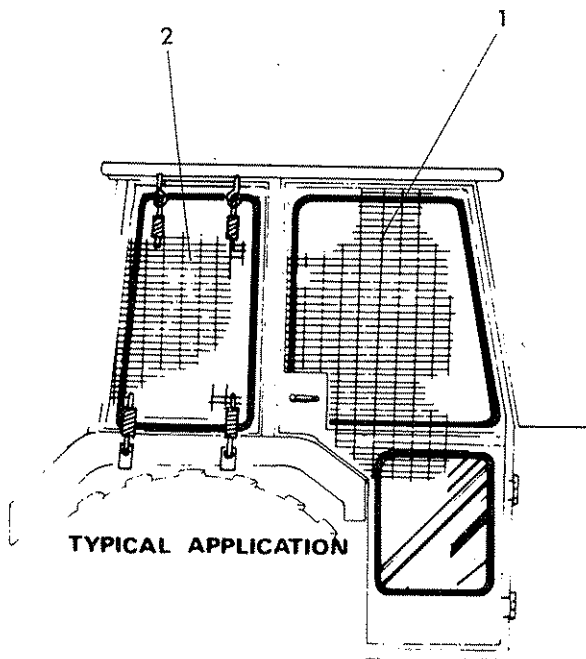
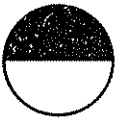

Ref.	Part No.	Qty.	Description
	<b>73-13-324</b>		<b>CAB GUARD KIT</b>
1	73-13-049	1	Guard panel - large
2	73-13-050	1	Guard panel - small
3	60-01-064	12	Spring
4	60-01-065	6	Hook
5	73-13-051	6	Hook

Model

HYDRAULIC INSTALLATION

**McCONEL**

Temeside Works, Ludlow,  
Shropshire, SY8 1JL, England.  
Telephone: (0584) 3131.  
Telex 35313. Facsimile: (0584) 6463.



Ti models only

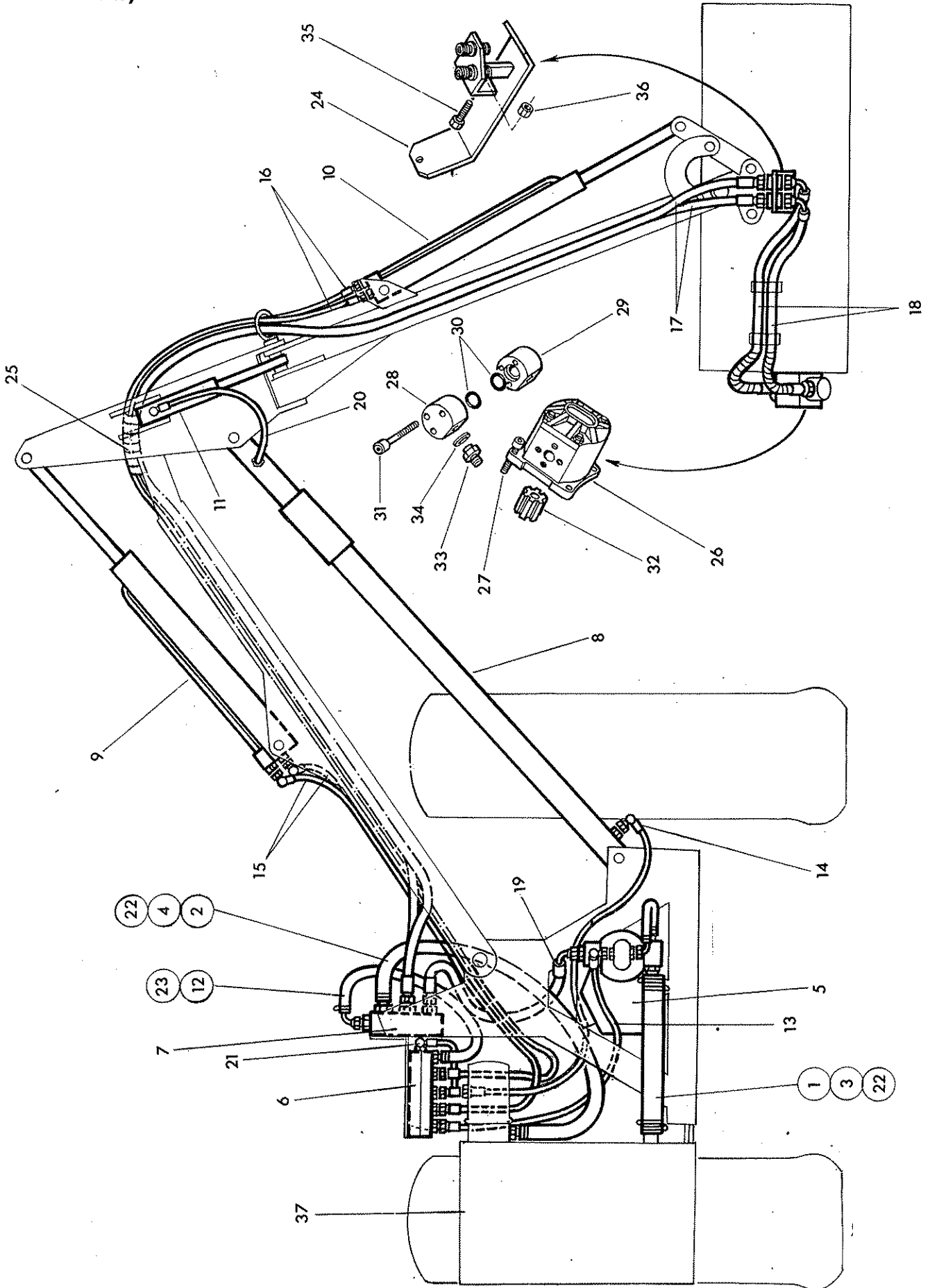

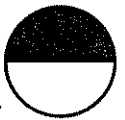

Ref.	Part NO	Qty.	Description
	80-17-306		<b>HYDRAULIC INSTALLATION FOR T.I. MACHINES WHEN PUMP IS MOUNTED AWAY FROM TANK</b> i.e. rear right and front left configurations
1	85-01-172	1	Suction Hose 1 $\frac{1}{4}$ " dia x 18" long
2	85-00-860	1	Return hose 1" dia x 60" long
	80-17-307		<b>HYDRAULIC INSTALLATION FOR TI MACHINES WHEN PUMP IS MOUNTED TOWARDS THE TANK</b> i.e. rear left and front right configurations
3	85-01-173	1	Suction hose 1 $\frac{1}{4}$ " dia x 14" long
4	85-00-830	1	Return hose 1" dia x 30" long
The remaining items are common to both T.I. hydraulic installations.			
5	80-13-351	1	Pump and gearbox assembly -see page 55
6	81-30-427	1	Armhead control valve assy -see page 61
7	81-25-345	1	Rotor control valve assy -see page 65
8	71-91-069	1	Lift ram assembly -see page 70
9	71-91-071	1	Reach ram assembly-see pae 71
10	71-91-073	1	Angling ram assembly-see page 72
11	71-91-298	1	Breakaway ram assembly see page 73
12	85-01-106	1	Hose 5/8"bore x 27"long-Return
13	85-31-458	1	Hose 3/4" J.I.C. x 45"long-Supply
14	85-35-067	1	Hose 1/2" J.I.C. x 48" long-Lift
15	85-35-107	2	Hose 1/2" JIC x 60"long-Reach
16	85-15-067	2	Hose 1/2" J.I.C.x134"long-Angle
17	85-01-175	2	Hose 7/8 J.I.C. x160"long-Rotor
18	85-01-176	2	Armoured Hose 7/8 J.I.C. x 42" long - Motor
19	85-01-174	1	Hose 7/8 J.I.C. x 42"long-Supply
20	85-35-087	1	Hose 1/2" J.I.C. x 22"long-Breakaway
21	85-35-077	1	Hose 1/2" J.I.C. x 17"long-Lift RV
22	09-04-107	8	Hose clip - large
23	09-04-204	2	Hose clip - small
24	71-91-316	1	Hose bracket
25	71-93-026	1	Hose armour
26	83-01-260	1	Hydraulic motor
27	93-00-136	4	Capscrew-Socket headed
28	71-91-055	1	Motor connector - R.Hand
29	71-91-056	1	Motor connection - L.Hand
30	86-00-121	2	'O' ring
31	93-00-014	6	Capscrew-socket headed
32	71-90-009	1	Drive coupling
33	85-81-271	2	Adaptor
34	86-50-106	2	Bonded seal
35	92-13-075	2	Bolt
36	91-43-005	2	Self locking nut
37			Oil tank assy-Ref only-see page 43

## Installation note

For R.Hand builds 5/8" and 1" low pressure hoses on rotor control are shown.

For L.Hand builds the connections are interchanged

Model

HYDRAULIC INSTALLATION

**McCONEL**

Temeside Works, Ludlow,  
Shropshire, SY8 1JL, England.  
Telephone: (0584) 3131.  
Telex 35313. Facsimile: (0584) 6463.



Si models only

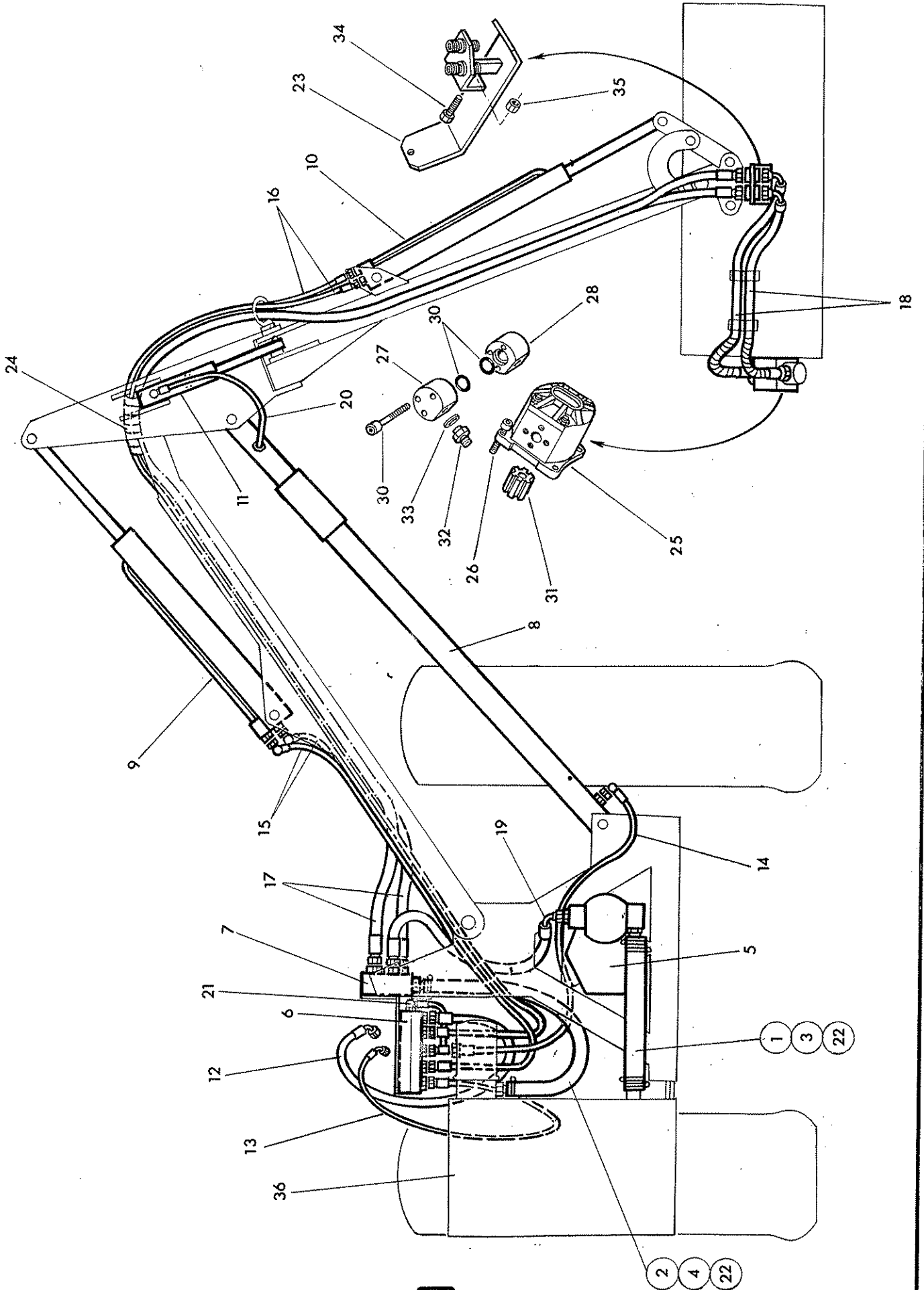

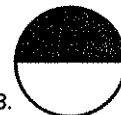

Ref.	Part No.	Qty.	Description
	80-17-308		<b>HYDRAULIC INSTALLATION FOR S.I MACHINES WHEN PUMP IS MOUNTED AWAY FROM TANK</b> i.e. rear right and front left configurations
1	85-01-172	1	Suction Hose 1½ dia x 18" long
2	85-00-860	1	Return hose 1" dia x 60" long
	80-17-309		<b>HYDRAULIC INSTALLATION FOR SI MACHINES WHEN PUMP IS MOUNTED TOWARDS THE TANK</b> i.e. rear left and front right configurations
3.	85-01-173	1	Suction hose 1½ dia x 14" long
4	85-00-83-	1	Return hose 1" dia x 30" long
The remaining items are common to both T.I. hydraulic installations.			
5	80-13-353	1	Pump and gearbox assembly -see page 57
6	81-30-428	1	Armhead control valve assy-see page 61
7	81-25-354	1	Rotor relief valve assy-See page 65
8	71-91-069	1	Lift ram assembly -see page 70
9	71-91-071	1	Reach ram assembly -see page 71
10	71-91-073	1	Angling ram assembly-see page 72
11	71-91-298	1	Breakaway ram assembly see page 73
12	85-32-019	1	Hose 7/8 J.I.C. x 80"long- Return
13	85-31-828	1	Hose 3/4 J.I.C. x 42" long- Supply
14	85-35-067	1	Hose ½" J.I.C. x 48" long-Lift
15	85-35-107	2	Hose ½" J.I.C. x 60"long-Reach
16	85-15-067	2	Hose ½" J.I.C. x 134"long-Angle
17	85-01-175	2	Hose 7/8 J.I.C. x 160"long-Rotor
18	85-01-176	2	Armoured Hose 7/8 J.I.C. x 42" long - Motor
19	85-01-174	1	Hose 7/8 J.I.C. x 42" long- Supply
20	85-35-087	1	Hose ½" J.I.C., x 22"long- Breakaway
21	85-35-077	1	Hose ½" J.I.C. x 17"long-Lift RV
22	09-04-107	8	Hose clip - large
23	71-91-316	1	Hose bracket
24	71-93-026	1	Hose armour
25	83-01-260	1	Hydraulic motor
26	93-00-136	4	Capscrew-Socket headed
27	71-91-055	1	Motor connection - R.Hand
28	71-91-056	1	Motor connection - L.Hand
29	86-00-121	2	'O' ring
30	93-00-014	6	Capscrew-socket headed
31	71-90-009	1	Drive coupling
32	85-81-271	2	Adaptor
33	86-50-106	2	Bonded seal
34	92-13-075	2	Bolt
35	91-43-005	2	Self locking nut
36			Oil tank assy- Ref only-See page 43

## Installation Note

For R.Hand builds 5/8" and 1" low pressure hoses on rotor control are shown.

For L. Hand builds the connections are interchanged

Model

**PUMP AND GEARBOX**

**McCONEL**

Temeside Works, Ludlow,  
Shropshire, SY8 1JL, England.  
Telephone: (0584) 3131.  
Telex 35313. Facsimile: (0584) 6463.



Ti only. illustrated in pump towards tank installation

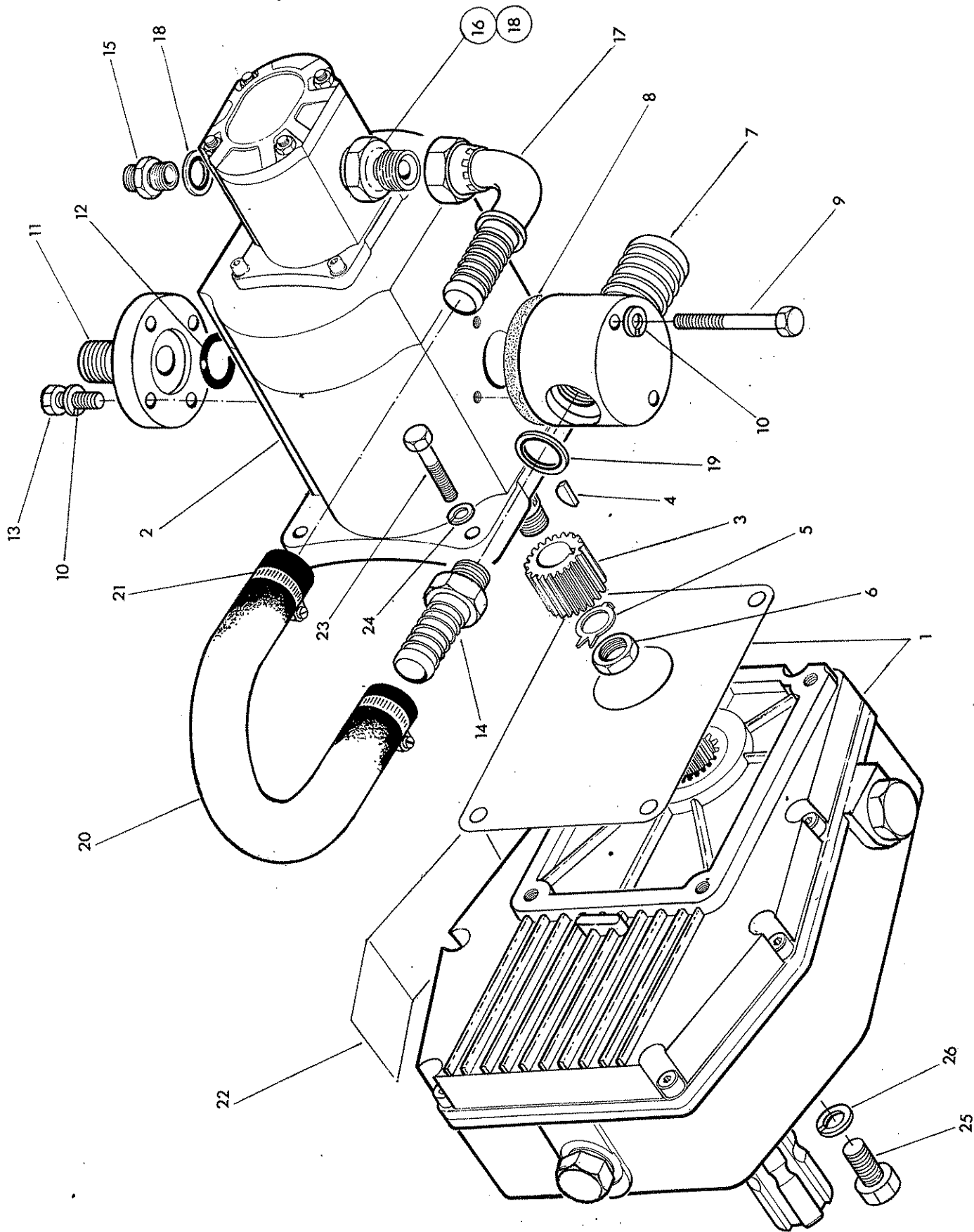

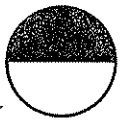

Ref.	Part No.	Qty.	Description
	<b>80-13-351</b>		<b>PUMP AND GEARBOX ASSEMBLY T.I. MODELS</b>
1	80-13-339	1	Gearbox assembly see page 59
2	82-01-458	1	Pump assembly CPL33/5.7 cw coupling etc
3	80-13-057	1	Coupling
4	83-01-010	1	Key
5	82-01-139	1	Tabwasher
6	91-00-015	1	Thin locknut
7	80-13-082	1	Suction connection
8	80-13-023	1	Gasket
9	92-13-144	2	Bolt
10	91-00-204	6	Spring washers
11	90-13-084	1	Pressure connection
12	86-00-119	1	'O' ring
13	93-13-054	4	Setscrew
14	90-02-059	2	Adaptor
15	85-80-170	1	Adaptor
16	85-81-175	1	Adaptor
17	85-81-173	1	Elbow
18	86-50-103	2	Bonded seal
19	86-50-104	1	Bonded seal
20	85-01-099	1	Hose 5/8" bore x 13" long
21	09-04-204	2	Hose clips
22	12-90-030	1	Sticker
23	92-13-095	4	Bolt
24	91-00-205	4	Spring washer
25	93-13-046	4	Setscrew
26	91-00-206	4	Spring washer
	<b>86-99-215</b>		<b>PUMP SEAL KIT</b>



Model

**PUMP AND GEARBOX**

**McCOMEL**

Temeside Works, Ludlow,  
Shropshire, SY8 1JL, England.  
Telephone: (0584) 3131.  
Telex 35313. Facsimile: (0584) 6463.



Si models only. illustrated in pump towards tank installation

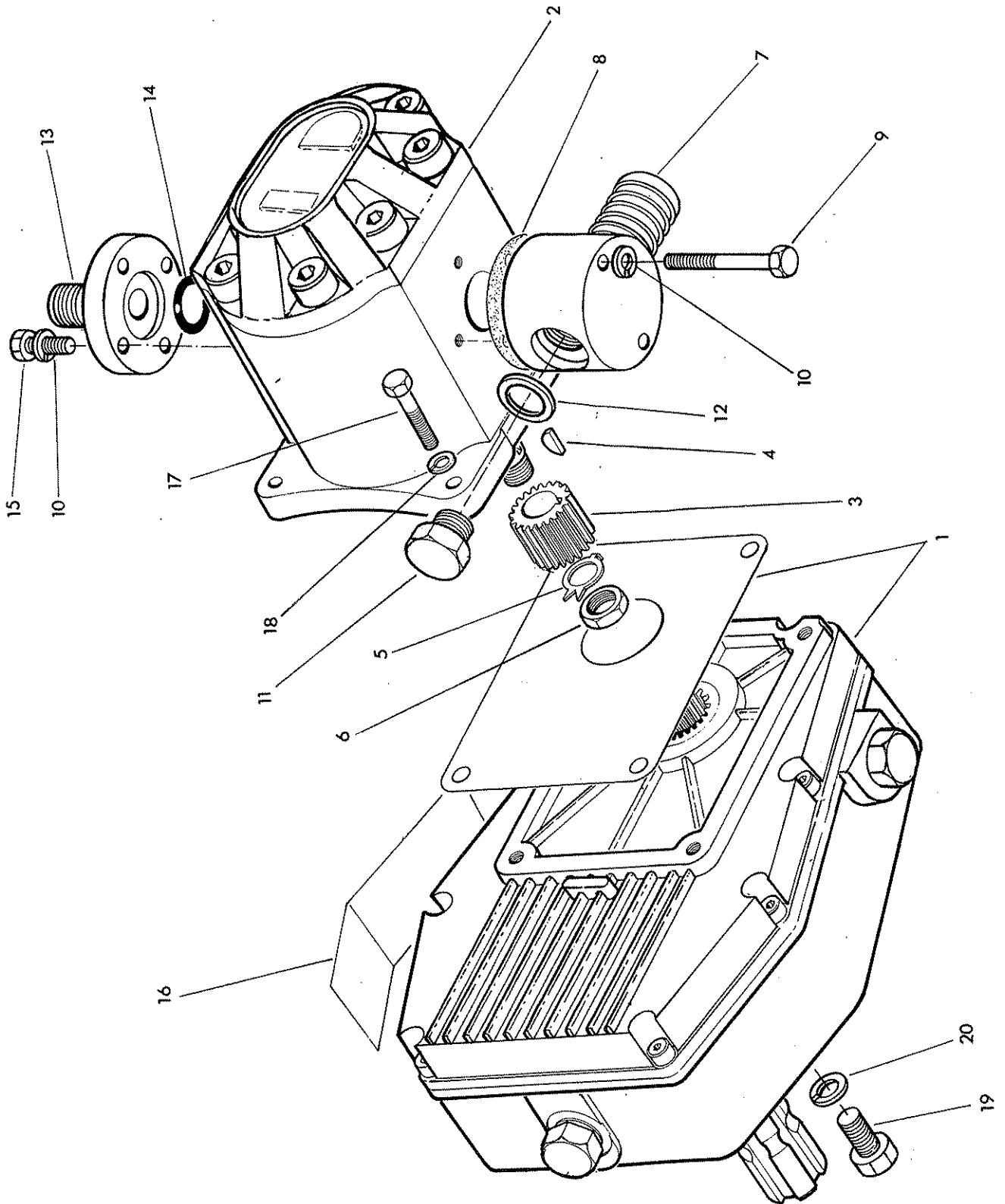



Ref.	Part No.	Qty.	Description
	80-13-353		<b>PUMP AND GEARBOX ASSEMBLY S.I. MODELS</b>
1	80-13-339	1	Gearbox assembly see page 59
2	82-01-457	1	Pump CPL 33D c/w coupling etc
3	80-13-057	1	Coupling
4	83-01-101	1	Key
5	82-01-139	1	Tabwasher
6	91-00-015	1	Thin locknut
7	80-13-082	1	Suction connection
8	80-13-023	1	Gasket
9	92-13-144	2	Bolt
10	91-00-204	6	Spring Washer
11	81-03-001	1	Hexagon plug
12	86-50-104	1	Bonded seal
13	80-13-084	1	Pressure connection
14	86-00-119	1	'O' ring
15	93-13-054	1	Setscrew
16	12-90-030	1	Sticker
17	92-13-095	4	Bolt
18	91-00-205	4	Spring washer
19	93-13-046	4	Setscrew
20	91-00-206	4	Spring washer
	86-99-215		<b>PUMP SEAL KIT</b>

Model  
**GEARBOX**

**McCONEL**

Temeside Works, Ludlow,  
Shropshire, SY8 1JL, England.  
Telephone: (0584) 3131.  
Telex 35313. Facsimile: (0584) 6463.

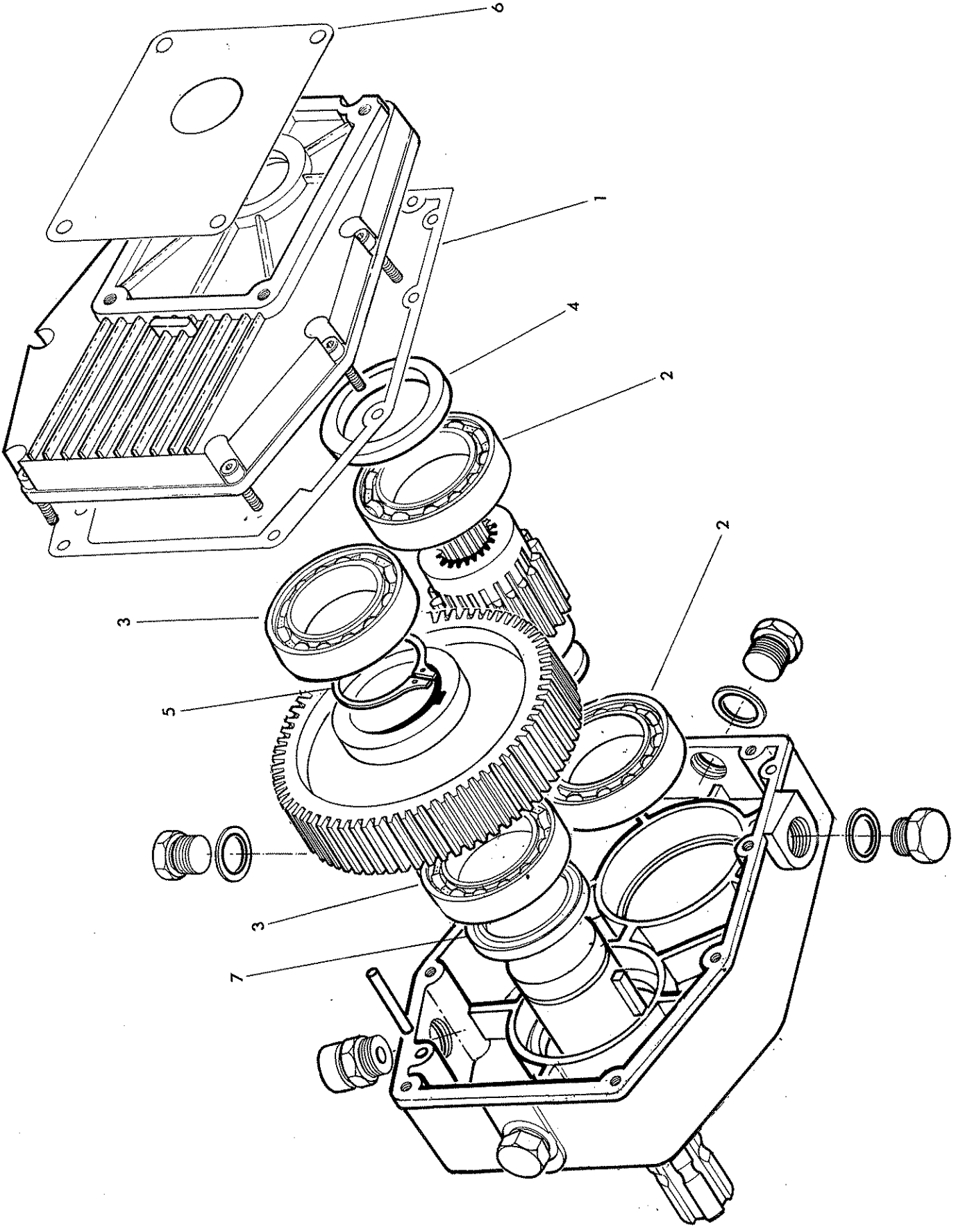
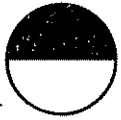

Model

**McCONEL**

Temeside Works, Ludlow,  
Shropshire, SY8 1JL, England.  
Telephone: (0584) 3131.  
Telex 35313. Facsimile: (0584) 6463.



Ref.	Part No.	Qty.	Description
	80-13-339	1	GEARBOX ASSEMBLY
1	80-13-087	1	.Gearbox case sealing gasket
2	06-00-047	2	.Bearing
3	06-00-048	2	.Bearing
4	86-29-139	1	.Seal
5	04-01-250	1	.External circlip
6	90-13-056	1	.Pump face gasket
7	86-29-134	1	.Seal

Model

**ARM CONTROL VALVE**

**McCONEL**

Temeside Works, Ludlow,  
Shropshire, SY8 1JL, England.  
Telephone: (0584) 3131.  
Telex 35313. Facsimile: (0584) 6463.

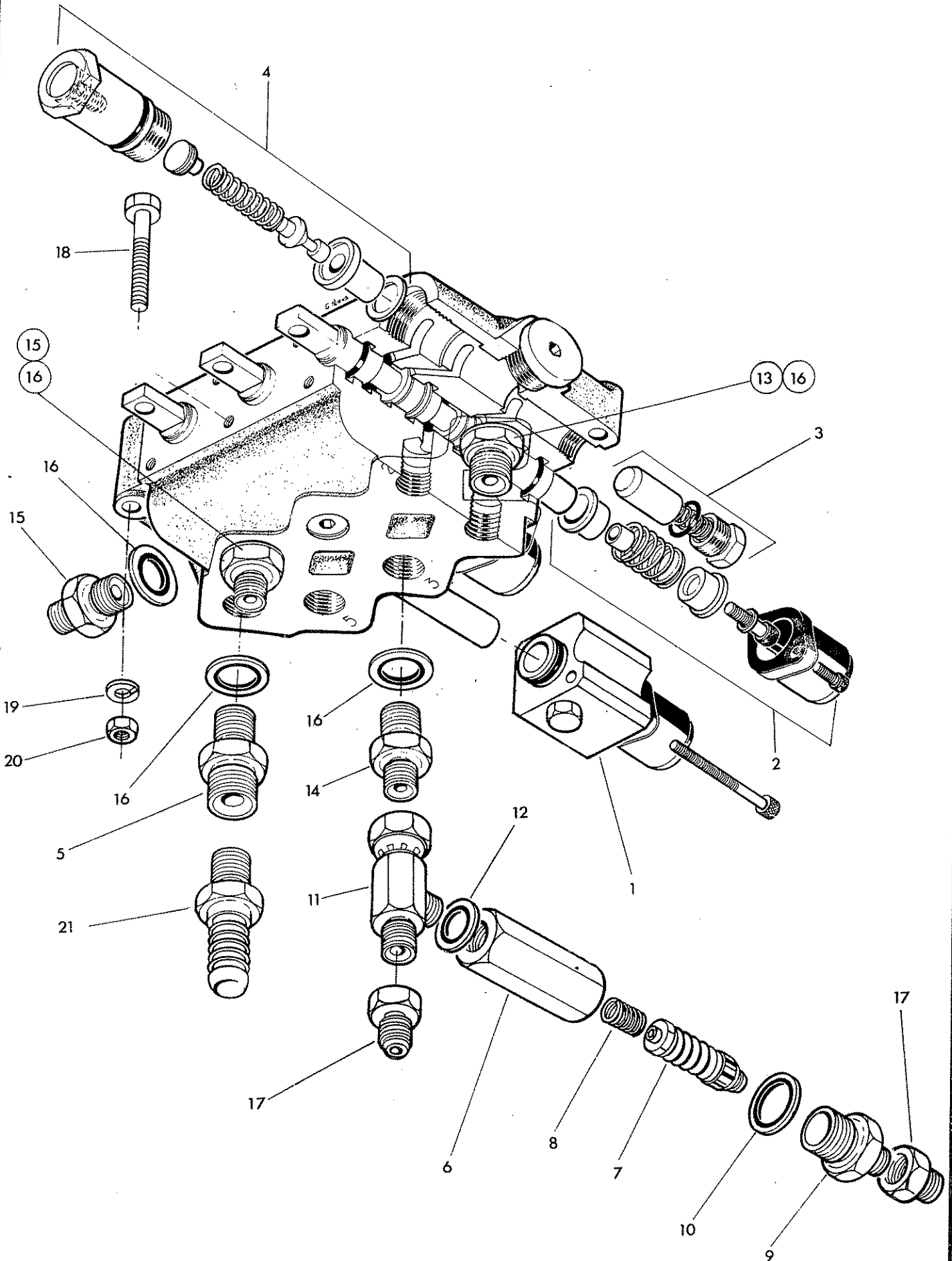

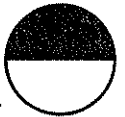

Ref.	Part No.	Qty.	Description
	81-30-428		HYDRAULIC CONTROL ASSEMBLY FOR PA91 S.I. MODEL
			CONTROL VALVE
1	81-30-084	1	Centering spring and detent assy-Angle
2	81-30-134	1	Centering spring assembly
3	81-30-022	1	Non-return valve assembly
4	81-30-149	1	Relief valve assembly 1800 psi (125Bar)
5	85-81-222	1	Adaptor
	81-30-155	1	Lift service relief valve assy compr:-
6	81-30-156	1	Relief valve housing
7	81-30-141	1	Relief valve
8	81-16-011	1	Spring
9	81-30-083	1	Relief valve body
10	86-50-104	1	Bonded seal
11	85-81-254	1	Tee
12	86-50-102	1	Bonded seal
13	85-81-170		Adaptor
14	85-81-115	1	Union
15	10-75-115	5	Adaptor
16	86-50-103	8	Bonded seal
17	85-81-232	2	Adaptor
18	92-13-124	3	Bolt
19	91-13-004	3	Nut
20	91-00-204	3	Spring washer
	86-00-163		SEAL KIT
	81-30-427		HYDRAULIC CONTROL ASSEMBLY FOR PA91 T. I MODEL

The parts list is identical to above with the following exceptions  
Item 5 becomes

2	81-25-008	1	Return connection
---	-----------	---	-------------------

Model

**MACHINE CONTROLS**

**McCONEL**

Temeside Works, Ludlow,  
Shropshire, SY8 1JL, England.  
Telephone: (0584) 3131.  
Telex 35313. Facsimile: (0584) 6463.

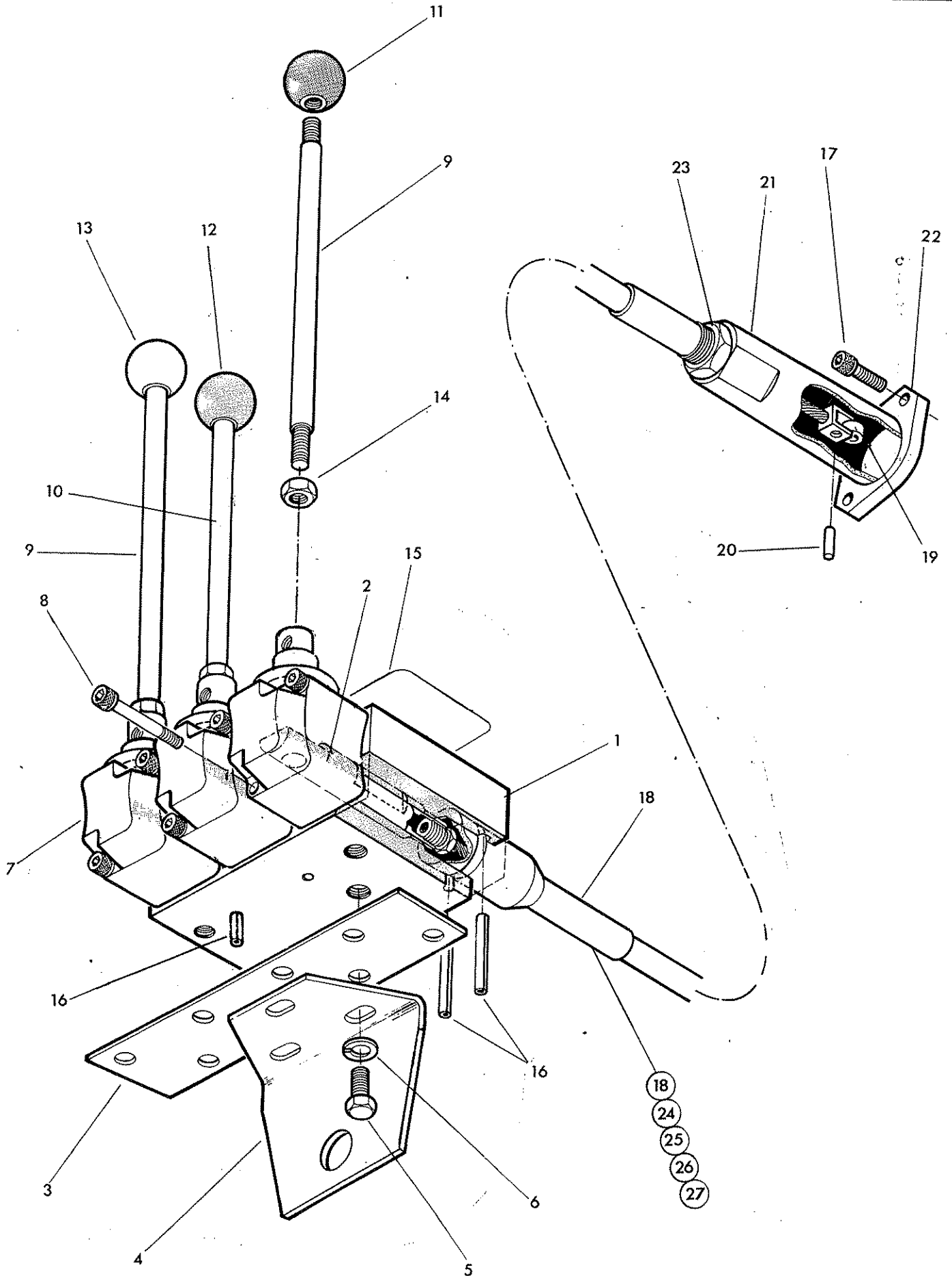

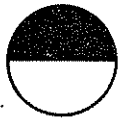

Ref.	Part No.	Qty.	Description
	81-30-425		HYDRAULIC CONTROL ASSY, FOR PA 91
	81-30-426		FULLY INDEPENDENT MODEL- continued HYDRAULIC CONTROL ASSY. FOR PA 91 SEMI INDEPENDENT MODEL ONLY-continued
1	81-30-391	1	Control block
2	81-30-144	3	Control block spindle
3	71-14-071	1	Control block mounting base
4	80-17-006	1	Mounting bracket
5	93-13-034	3	Setscrew
6	01-00-102	3	Thin washer
7	81-30-065	3	Lever pivot box assembly
8	92-43-072	6	Socket headed capscrew
9	71-09-131	2	Lever handle long
10	71-09-132	1	Lever handle short
11	09-03-112	1	Lever knob -Reach (Red)
12	09-03-113	1	Lever knob-Angle (Green)
13	09-03-114	1	Lever knob-Lift (Yellow)
14	91-13-004	3	Hexagon nut
15	12-90-368	1	Operating instruction label
16	04-25-525	9	Spring dowel
17	93-43-022	6	Socket headed capscrew
18*	80-17-003	3	Cable & spacer and pin, sleeve, flange etc.
15	71-15-158	1	Spool eye bush
20	71-15-160	1	Pin
21	71-15-162	1	Sleeve
22	81-25-050	1	Flange
23	01-31-006	1	Thin locknut

\* An alternative cable assembly may be fitted depending on supply availability.

The complete assembly is interchangeable and thus retains the same assembly Part Number i.e. 80-17-003

Individual cable components are not interchangeable thus before ordering spares the cable must be correctly identified.

The cable listed  is  
BLACK

The alternative cable is   
RED and consists of

18	80-17-003	1	Cable assembly c/w sleeve, flange etc.
19	81-25-049	1	Cable sleeve
20	81-25-050	1	Flange
21	81-25-051	1	Pin
22	91-00-016	1	Thin locknut
23	80-17-004	1	Spool eye bush

cable assemblies are:-

<input checked="" type="checkbox"/> 24	G241-0627	1	Cable assembly 1.5 metres
<input checked="" type="checkbox"/> 25	G241-0630	1	Cable assembly 2.5 metres
<input checked="" type="checkbox"/> 26	80 17 007	1	Cable assembly 3.0 metres
<input checked="" type="checkbox"/> 27	80 17 008	1	Cable assembly 4.0 metres







Ref.	Part No.	Qty.	Description
	81-25-345		ROTOR CONTROL VALVE ASSEMBLY
1	81-25-343	1	Rotor control valve
2	81-25-095	1	Relief valve 3000 PSI (210 Bar)
3	85-81-270	1	Adaptor
4	85-81-246	1	Adaptor
5	85-81-173	1	Elbow
6	86-50-106	2	Bonded seal
7	81-25-096	1	Cable assembly c/w sleeve flange etc
8	81-25-097	1	Sleeve
9	81-25-098	1	Flange
10	81-25-099	1	Pin
11	81-25-100	1	Bush
12	01-31-006	1	Thin locknut
13	93-43-033	2	Capscrew - socket headed
14	81-25-093	1	Control block
15	81-30-053	1	Control spindle
16	04-25-525	3	Spring dowel
17	81-30-065	1	Pivot box assembly
18	92-13-072	2	Capscrew - socket headed
19	81-25-089	1	Lever control gate
20	93-13-034	4	Setscrew
21	91-00-204	4	Spring washer dia
22	12-90-027	1	Operating label
23	71-14-072	1	Lever
24	09-03-121	1	Knob - black
25	91-13-004	1	Thin nut
26	92-13-164	3	Bolt
27	91-13-004	3	Nut
28	91-00-204	3	Spring washer
29	85-81-226	3	Adaptor
30	86-50-104	3	Bonded seal
	86-99-218		SEAL KIT

**\*Installation note**

L.Hand builds as illustrated

R. Hand builds - Item 6 is positionally interchanged with item 7 and 1 off item 5.

**Spares note**

Alternative cable assemblies are:-

31	81-25-102	1	Cable assembly - 3 metres
32	81-25-103	1	Cable assembly - 4 metres

Model

LIFT FLOAT KIT

**McCONEL**

Temeside Works, Ludlow,  
Shropshire, SY8 1JL, England.  
Telephone: (0584) 3131.  
Telex 35313. Facsimile: (0584) 6463.



Optional extra

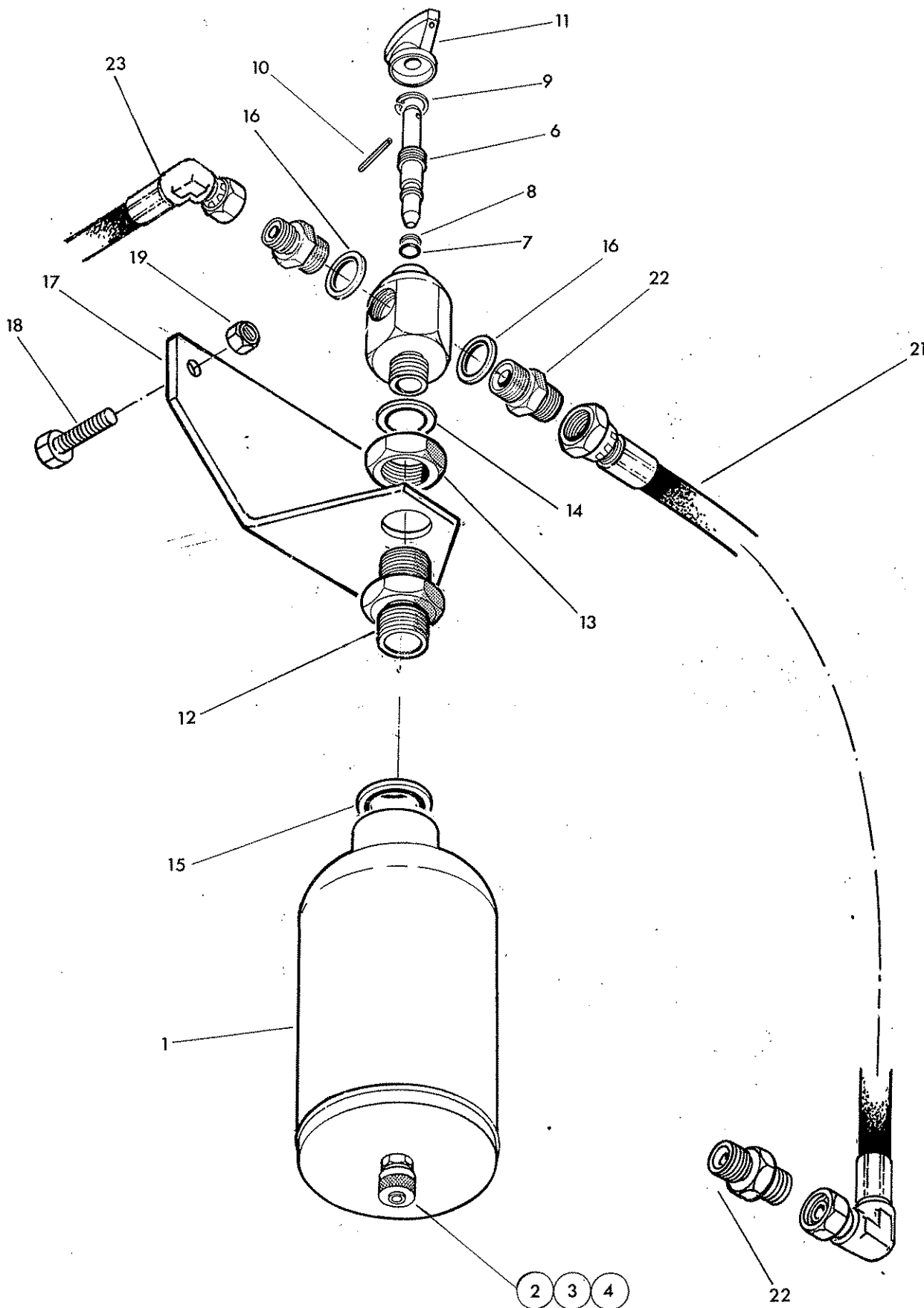

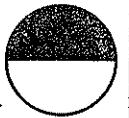

Ref.	Part No.	Qty.	Description
	81-26-279		LIFT FLOAT ASSEMBLY
1	81-26-271	1	Accumulator 600 PSI (41 Bar)
2	81-26-015	1	Charge valve assy. cw 'O' rings
3	81-26-016	1	Charge valve core
4	86-00-103	1	'O' ring
	71-35-007	1	Tap assembly compr:-
5	71-35-294	1	Tap body
6	71-35-006	1	Tap spindle
7	86-00-107	1	'O' ring
8	86-00-107	1	Anti extrusion ring
9	04-16-110	1	Internal circlip
10	04-20-820	1	Spring dowel
11	81-08-006	1	Knob
12	85-81-205	1	Adaptor
13	85-81-151	1	Backnut
14	86-50-102	1	Bonded seal
15	86-50-106	1	Bonded seal
16	86-50-103	2	Bonded seal
17	71-91-101	1	Mounting bracket
18	93-13-044	2	Setscrew
19	91-43-004	2	Self locking nut
20	12-90-029	1	Pre-charge label -not illus
21	85-31-458	1	Hose 3/4" JIC x 45" long
22	85-81-170	1	Adaptor
23	85-35-077	1	Hose 1/2 J.I.C.
	86-99-195		SEAL KIT

Model

**ROTOR RELIEF VALVE**

**McCONEL**

Temeside Works, Ludlow,  
Shropshire, SY8 1JL, England.  
Telephone: (0584) 3131.  
Telex 35313. Facsimile: (0584) 6463.



Si models only

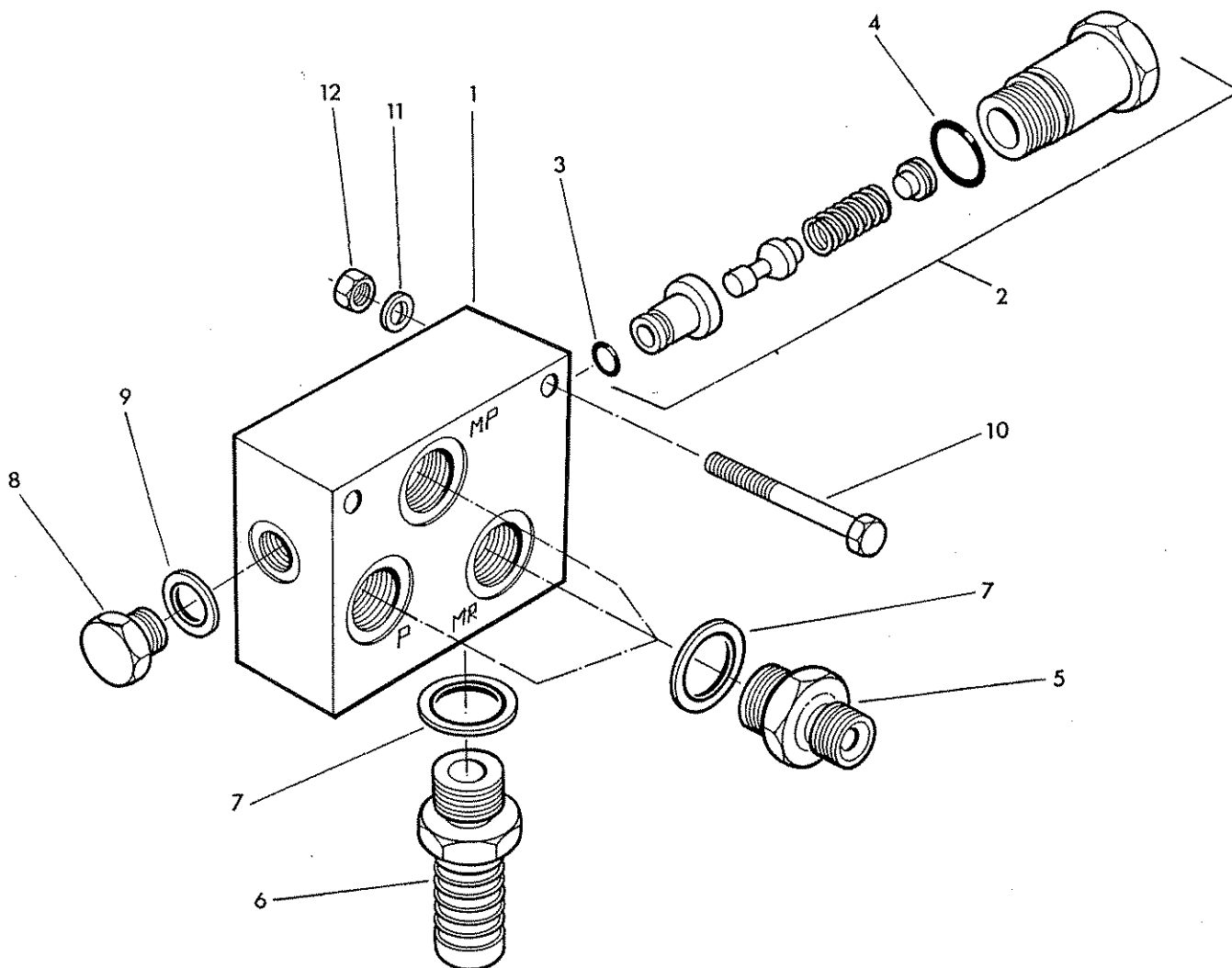

Ref.	Part No.	Qty.	Description
	<b>81-25-354</b>		<b>ROTOR RELIEF VALVE ASSEMBLY-SI MODELS ONLY</b>
1	81-25-352	1	Valve block
2	81-25-095	1	Relief valve 3000 PSI (207 Bar)incl.
3	86-00-505	1	'O' ring
4	86-00-507	1	'O' ring
5	85-81-271	3	Adaptor
6	85-81-246	1	Adaptor connection
7	86-50-106	4	Bonded seal
8	80-03-001	1	Hexagon plug
9	86-50-103	1	Bonded seal
10	92-13-164	2	Bolt
11	91-13-004	2	Nut
12	91-00-204	2	Spring washer

Model

LIFT RAM

**McCONEL**

Temeside Works, Ludlow,  
Shropshire, SY8 1JL, England.  
Telephone: (0584) 3131.  
Telex 35313. Facsimile: (0584) 6463.

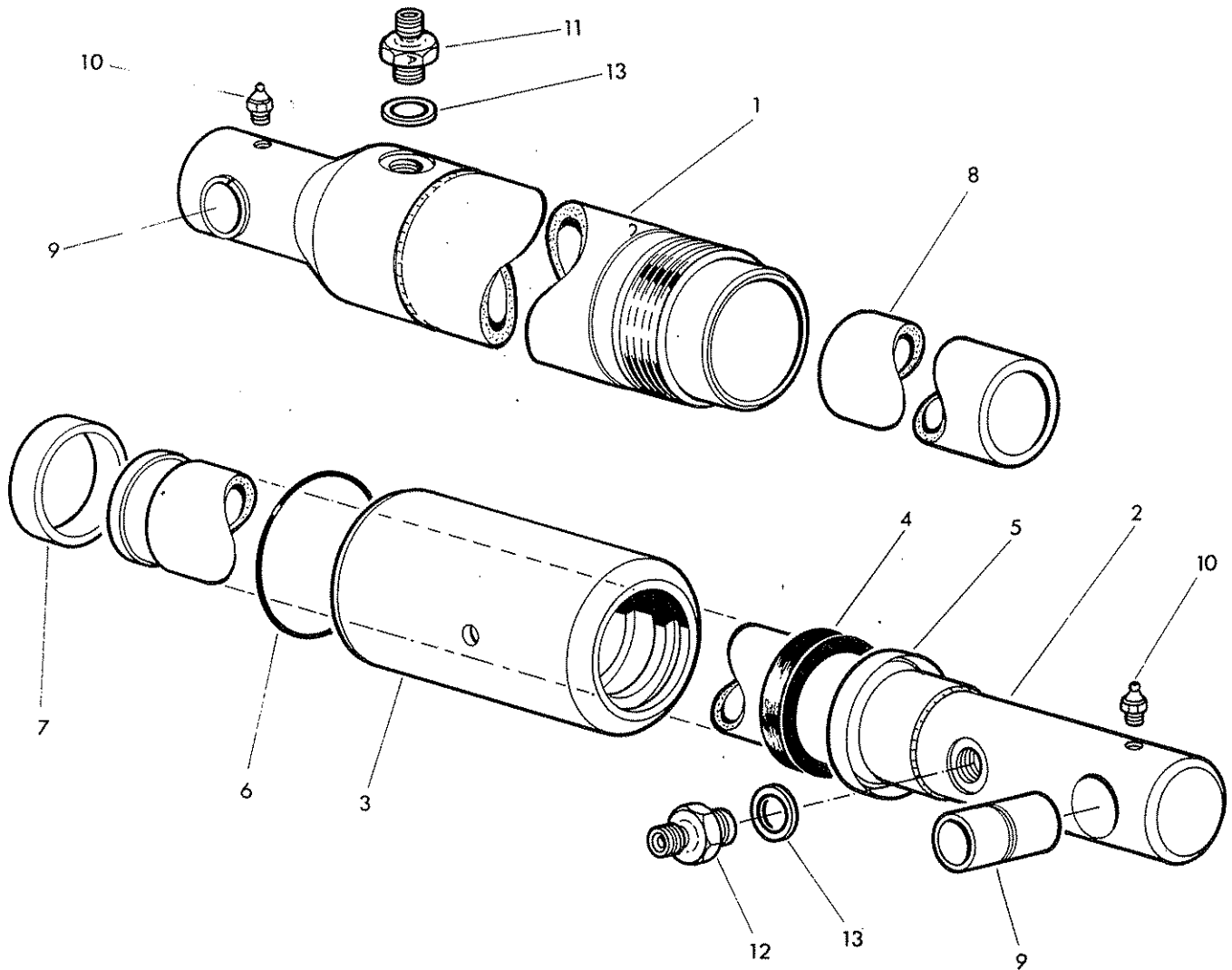

Ref.	Part No.	Qty.	Description
	<b>71-91-069</b>		<b>LIFT RAM ASSEMBLY</b>
	71-91-290	1	Basic ram compr:-
1	71-91-291	1	Ram barrel
2	71-91-047	1	Rod
3	71-91-292	1	Barrel head
4	86-29-175	1	Rod seal
5	86-29-176	1	Wiper seal
6	86-00-433	1	'O' ring
7	86-29-177	1	Bearing ring
8	71-91-060	1	Stop tube
9	71-06-050	2	Bush
10	09-01-121	2	Greaser
11	81-30-132	2	Restrictor union A
12	10-75-115	1	Adaptor
13	86-50-103	2	Bonded seal

Model

**McCONEL**

Temeside Works, Ludlow,  
Shropshire, SY8 1JL, England.  
Telephone: (0584) 3131.  
Telex 35313. Facsimile: (0584) 6463.

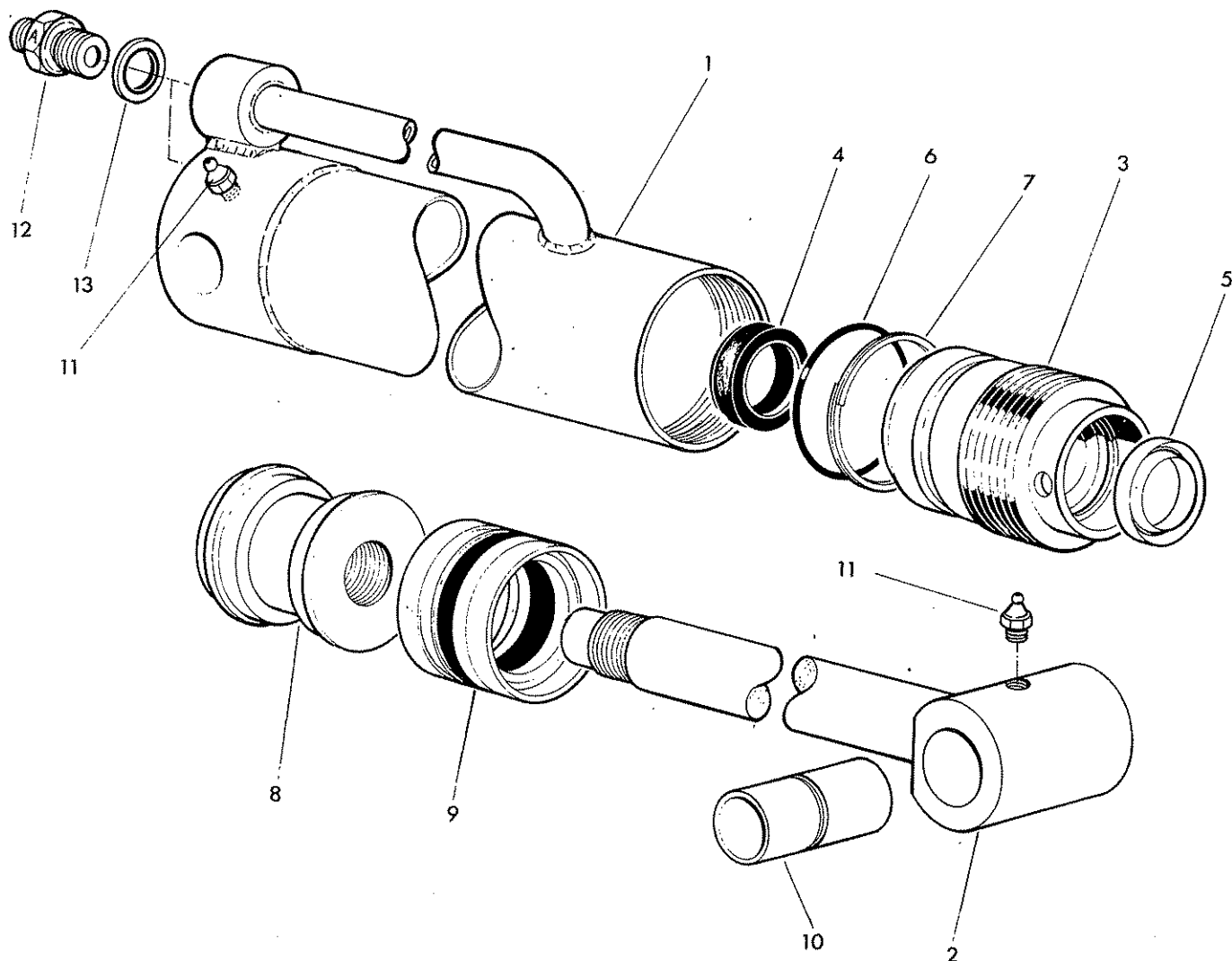
**REACH RAM**

Ref.	Part No.	Qty.	Description
	71-91-071		REACH RAM ASSEMBLY
	71-91-294	1	Ram basic comprising:-
1	71-91-306	1	Cylinder barrel
2	71-91-307	1	Piston rod
3	11-86-512	1	Gland housing
4	86-29-164	1	Gland seal
5	86-29-147	1	Wiper seal
6	86-00-306	1	'O' ring
7	86-09-306	1	Anti extrusion ring
8	71-36-063/1	1	Piston
9	86-36-001	1	Piston seal
10	71-05-050	1	Bush - rod end
11	09-01-121	2	Greaser
12	81-30-132	2	Restrictor union A
13	86-50-103	2	Bonded seal
	86-99-217		SEAL KIT

Model

**McCONEL**

Temeside Works, Ludlow,  
Shropshire, SY8 1JL, England.  
Telephone: (0584) 3131.  
Telex 35313. Facsimile: (0584) 6463.

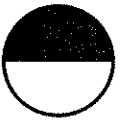
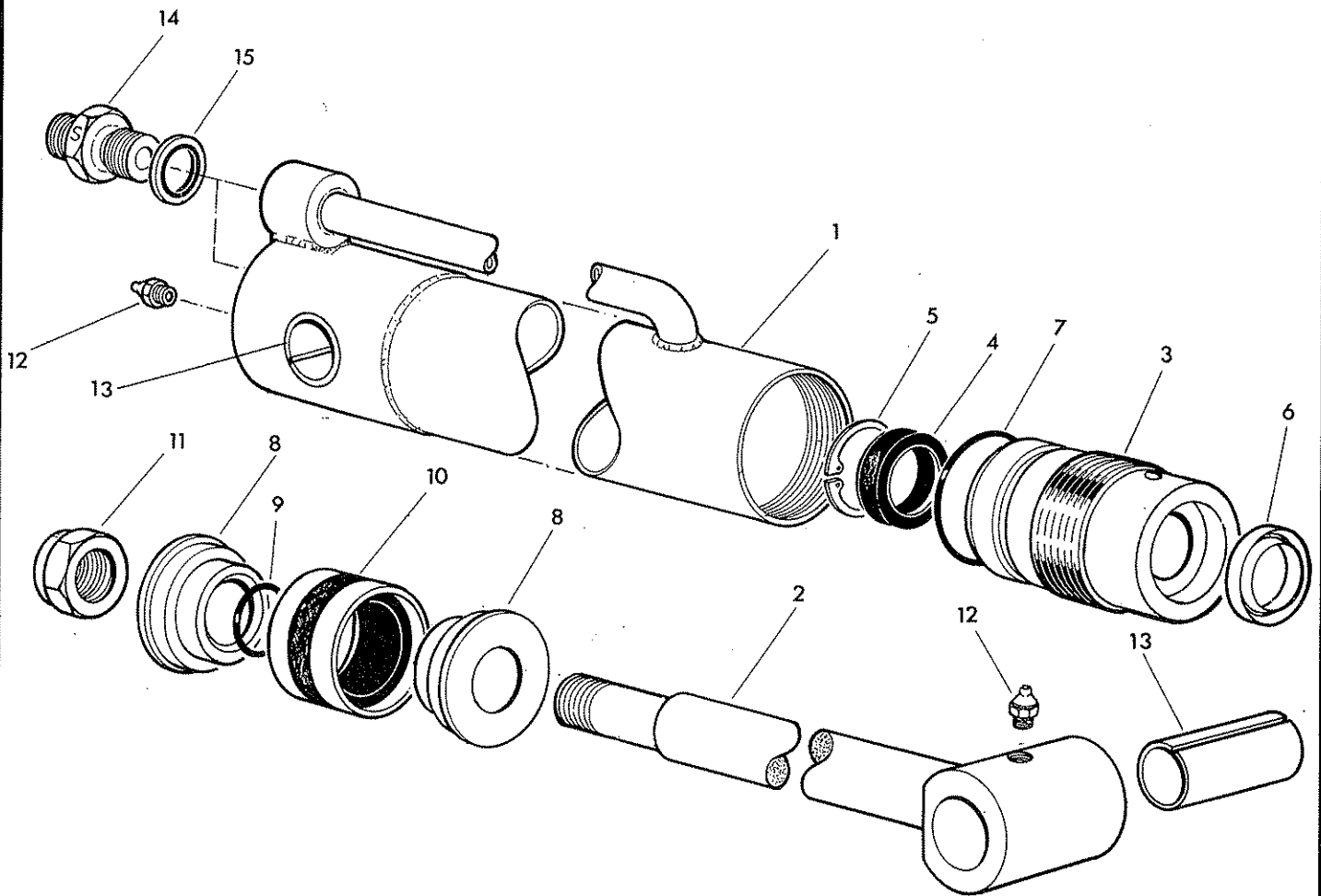
**ANGLING RAM**

Ref.	Part No.	Qty.	Description
	<b>71-91-073</b>	<b>1</b>	<b>ANGLING RAM ASSEMBLY</b>
	71-91-295	1	Ram basic - comprising
1	71-91-296	1	Cylinder
2	10-90-031	1	Piston rod
3	10-90-273	1	Gland nut
4	86-29-162	1	Gland seal
5	04-16-234	1	Circlip
6	86-29-161	1	Wiper seal
7	86-00-123	1	'O' ring
8	10-90-034	1	Piston
9	86-00-112	1	'O' Ring
10	86-29-160	1	Piston seal
11	01-41-007	1	Self locking nut
12	09-01-121	1	Greaser
13	10-90-005	2	Bush
14	81-30-158	2	Restrictor union S
15	86-50-102	2	Bonded seal

86-99-202

**SEAL KIT**

Assembly note.

Assemble locknut onto rod using  
'Permabond A113' or similar medium  
strength thread locking compound



Model

**BREAKAWAY RAM**

**McCONEL**

Temeside Works, Ludlow,  
Shropshire, SY8 1JL, England.  
Telephone: (0584) 3131.  
Telex 35313. Facsimile: (0584) 6463.

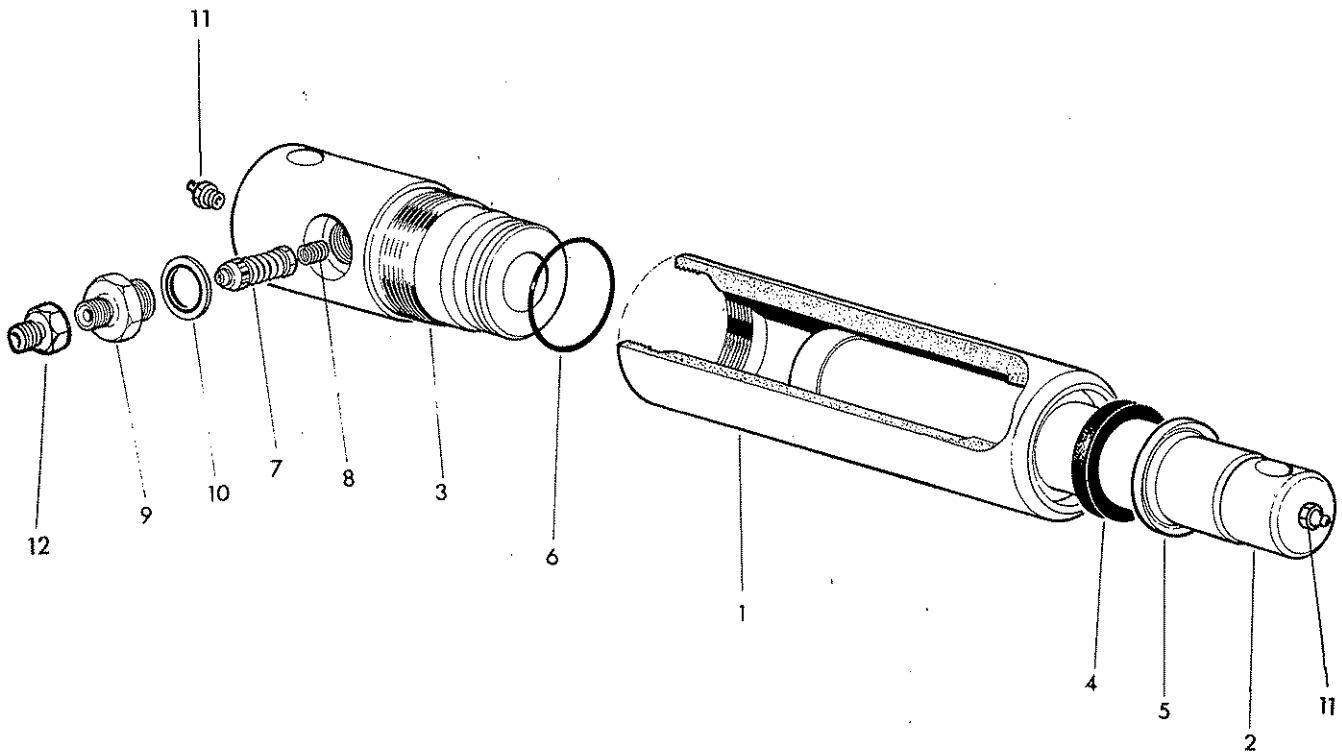

Ref.	Part No.	Qty.	Description
	<b>71-91-298</b>		<b>BREAKAWAY RAM</b>
1	71-91-308	1	Ram Barrel
2	71-91-051	1	Rod
3	71-91-299	1	Ram base
4	86-29-158	1	Rod seal
5	86-29-152	1	Wiper seal
6	86-00-302	1	'O' ring
7	81-30-141	1	Relief valve (900Psi/63Bar) code 05
8	81-16-011	1	Spring
9	81-30-083	1	Relief valve body
10	86-50-104	1	Bonded seal
11	09-01-121	1	Greaser
12	85-81-232	1	Adaptor



McConnel Limited, Temeside Works, Ludlow, Shropshire SY8 1JL. England.  
Telephone: 01584 873131. Facsimile: 01584 876463. [www.mcconnel.com](http://www.mcconnel.com)