Kellands



Agribuggy

2700

THE AGRIBUGGY 2700

LOW GROUND PRESSURE VEHICLE

OPERATOR INSTRUCTION MANUAL

MANUFACTURED BY:

Kellands Agricultural Limited.
Brimpsfield Rd., Birdlip, Gloucestershire. GL4 8JH

Tel.: 01452 863900
Fax: 01452 863400
e-mail: sales@kellands.co.uk

THE AGRIBUGGY 2700

OPERATOR INSTRUCTION MANUAL

INTRODUCTION

THIS MANUAL SHOULD BE KEPT WITH THE MACHINE AT ALL TIMES AND SHOULD BE READ BY ALL OPERATORS BEFORE USING, MAINTAINING OR REPAIRING THE MACHINE.

The Agribuggy 2700 is powered by a diesel engine with automatic transmission and transfer box, providing mechanical drive to hub reduction axles. As standard it is four wheel drive and has all wheel steer. To optimise weight distribution between all wheels it is of forward control configuration and constructed to achieve low ground pressure whilst maintaining durability.

IT IS SOLELY INTENDED for use in agricultural or similar operations, it has been designed specifically for use as a crop spraying and fertiliser spreading and therefore does not come within the scope of the Agriculture (Tractor Cabs) regulations. It should, therefore, not be used for any other purpose and should not be used for towing or be fitted with any other equipment unless approved by the manufacturer. The use of this machine in any other way is considered to be contrary to the intended use. The manufacturer accepts no liability for damage or personal injury resulting from improper use. These risks will be borne solely by the user. Improper use includes, but is not limited to the overloading of the machine and operating at excessive speeds for the prevailing conditions and or operation being performed. Operators are warned that improper use may lead to serious loss and injury. In the case of improper use the warranty may be invalidated.

Road Safety – When driving on public roads it is important to obey road safety regulations.

It is important that only correctly qualified people undertake operation, maintenance and repair of this machine.

After reading this manual and becoming acquainted with the Agribuggy it is recommended that you fill the sprayer with water only and have a trial run in a grass or stubble field. It is important that you get used to all aspects of operating the machine before applying chemicals.

Issue 7 - 22/5/2013 – ‘Original Instruction’ applicable to machines manufactured from January 2013

© Kellands Agricultural Ltd 2012

Table of contents - Agribuggy 2700

Company address	2		
Introduction	3		
Table of Contents	4	Service & Warranty	21
EC Declaration of Conformity	5		
Safety Precautions	7	Daily Maintenance Points – Engine	22
Machine Operation:		Maintenance & Technical Information:	23
Running in	8	Engine oil	22
Main driving controls	8	Changing oil filter	24
Starting engine	8	Adjusting belts	25
Stopping engine	9	Hydraulic pump drive	26
Dashboard controls	9	Cooling fan	26
Handbrake	10	Cooling system	27
Power steering	10	Fuel system	28
Throttle	10	Hydraulic system	29
Automatic transmission	10/11	Hyd oil & filter/Air cleaning system	30
Transmission temperature	11	Screen wash	31
Transfer gearbox	12	Cab filtration	31
Differential lock	12	Air conditioning	31
Foot brakes	13	Automatic transmission	32
Drivers seat	13	Transfer gearbox	32
RDS Monitors	14	Battery	32
Warning / safety systems	14	Electrical	32
Instrumentation	14	Fuses	33-35
Trip-tronic	15	Handbrake	36
Hand throttle & Cruise control	16	Footbrakes	36
Hydraulic PTO system	17	Steering	37
Spool valves/electro-hydraulics	17	Axle drive shafts	38
Air conditioning/ventilation	17/18	Wheel hubs / bearings	38
Emergency cab exit	18	Axle oil levels	38
Row crop work	19	Wheel alignment	39
		Greasing	39
Field Operation:		Tyres	39
Field planning	19	Cleaning	39
Potatoes	20		
Sugar beet	20	Maintenance Schedule	40
Choice of jets	20		
Forward speed	20	Parts	41
Fertiliser Spreading:	20	Appendices	
Centreliner spreaders	20	1 Four wheel steering	42-44
		2 Row crop wheel settings	45



Safety Precautions

For your own and, more importantly, other peoples safety please read this section carefully and remember the points made.

1. The machine should only be used, maintained and repaired by qualified people familiar with it and in doing so they should comply with the operating, maintenance and safety instructions in this manual.
2. The machine should not be driven at speeds in excess of 30 m.p.h. (50kph)
3. Maximum laden weight should not exceed 7.5 tonnes
4. Keep all nuts & bolts tight.
5. Do not permit any person to ride on the machine other than the driver.
6. Stop engine, apply parking brake and ensure gearshift is in "Park" before leaving seat.
7. Great care should be exercised when operating on steep gradients to maintain proper stability.
8. Always keep machine in gear when going downhill. Ensure 1st gear is selected on steep hills.
9. Brakes should always be kept in proper operating condition.
10. Ensure speed is low enough for an emergency stop to be effective under all load conditions.
11. Ensure all guards, covers and access panels are fitted at all times.
12. Ensure engine is stopped and handbrake applied before carrying out adjustments or lubrication.
13. Engine must be stopped before connecting, disconnecting or making any adjustment to the hydraulic power take off.
14. Never start the engine other than from the driving position.
15. Select neutral or "Park" and depress foot brake before starting engine.
16. The machine should be regularly maintained as per the maintenance schedule in this manual.
17. Before carrying out any repairs or welding on the Agribuggy, the sprayer or the spreader, remove all chemical and fertiliser residues with a pressure washer or steam cleaner together with a suitable detergent and brushing if necessary - Burning chemical fumes are extremely toxic - Ammonium Nitrate (e.g. Nitram) can be explosive. Chemical residues are extremely hazardous to anyone working on the machine. Disconnect the batteries and isolate the ECUs.
18. Hose machine down regularly - do not allow dirt / fertilisers to build up on the engine, particularly ammonium nitrate - this can create a fire hazard!
19. Always ensure that personal protective equipment appropriate to the task to be performed is used/ worn.

NB If any factory or field repairs have to be carried out on a contaminated machine we reserve the right to either refuse to carry out the work or to charge for any necessary cleaning.

Agricultural chemicals can be very dangerous. Improper selection or use can seriously injure people, animals, plants, the soil or other property. Be safe: select the right chemical for the job. Handle it with care. Follow the instructions on the container label and instructions for the spraying equipment.

Operation - Driving controls

Running in

There are no strict running in rules for the International diesel engine. However, do not treat it harshly during the first fifty hours running. Avoid consistently high speeds above 3000 rpm but do not let the engine labour. There should always be a positive response from the throttle. Select the right gear for the job. Be prepared to reduce your working speed if necessary. Check the instruments frequently and keep the coolant and oil filled to their recommended levels on a daily basis.

After the running in period speeds should be progressively increased up to maximum performance. The engine should not be run continually above 3500 rpm and should never exceed 4000 rpm (3500 rpm if fitted with high power PTO system - see appendices) or damage to the hydraulic system may result.

After completing the first 50 hours running, carry out the maintenance instructions summarised in the maintenance section of this manual.

Main Controls



Starting engine

1. Ensure PTO is disengaged, handbrake applied and gearshift in Park or Neutral before starting.
2. Depress the brake and, turn the ignition switch to the center position, wait for 5 seconds.
3. Crank the engine by turning the key fully clockwise. Release key when engine starts. If it doesn't start within 20 seconds or starts and then stops, return the key to the off position, wait a few seconds and then repeat the above procedure.
4. The accelerator will not function until the engine is sufficiently warm. This will let the engine idle for a few seconds and allow oil to reach the turbo-charger. Avoid high engine revs until the engine and hydraulic system have warmed up.

After starting, ensure that the handbrake or footbrake are firmly applied and the accelerator pedal is not depressed while moving the gear selector lever from 'N' or 'P', otherwise the vehicle may move immediately the selector lever is moved to one of the drive positions. This is particularly important whilst the engine is cold, because the engine will be idling at a faster speed than normal.

Operation - Controls

Stopping engine

Before stopping engine ensure vehicle has completely stopped, when stationary apply handbrake and select 'Park'.

Allow engine to slow idle for at least 10 seconds before stopping particularly if you have been running at high engine revs to avoid damage to the turbo-charger bearings. If the engine stalls at any point, try to restart immediately.

To stop engine turn the key anticlockwise.

Dashboard controls

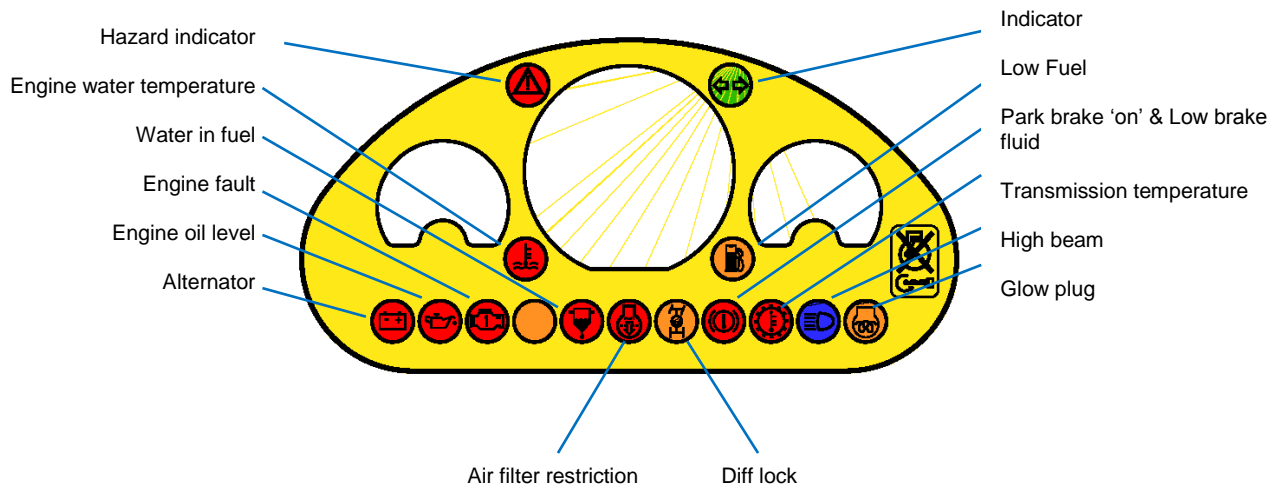

Operation - Auto transmission

Handbrake

Situated at the right hand side of the operators seat and to be operated only when stationary. It should not be applied, other than in an emergency, whilst the vehicle is in motion or transmission damage may result.

The brake operates on the rear drive shaft which may result in a slight movement of the vehicle after it is applied.

Power steering

When turning do not hold the steering tight on full lock as this will cause the relief valve to blow off and the hydraulic system to overheat. Do not turn the steering whilst the Agribuggy is stationary particularly when on hard surfaces. This causes unnecessary, excessive pressures in the steering system especially when wide tyres are fitted.

For information on the optional four wheel steering system please see appendix 1 towards the rear of this manual.

To adjust the steering wheel position slacken the lever on the left hand side of the column and move the wheel backwards and forwards and up/down until you find the most comfortable driving position and then re-lock by turning the lever clockwise. Do not adjust whilst driving!

Throttle

When driving the Agribuggy with the foot throttle, try to anticipate tough spots and be ready to respond with relatively large movements of the throttle to avoid the engine losing speed. With a little practice you will find a constant speed can quite easily be maintained. In Addition to the foot throttle the Agribuggy is fitted with a remote throttle and a cruise control function. The remote throttle fitted outside the cab on the nearside engine panel is to enable the PTO speed to be held at 540 rpm when stationary for self-filling the sprayer. Instruction on the operation of the hand throttle and cruise control please refer to pages 15 and 16 of this manual.

Ensure that the remote throttle is returned to the tick-over position on the toggle switch immediately after use.

Do not leave the machine unattended when the remote throttle is being used.

Automatic-transmission

The automatic transmission features a four speed main gearbox with a torque converter and a two speed transfer box. A central differential in the transfer gearbox distributes power to both front and rear axles, providing permanent four wheel drive. Using the main gearbox in conjunction with the transfer gearing produces eight forward and two reverse speeds.

Main gearbox selector lever

A spring loaded catch restricts movement of the lever, thereby preventing inadvertent gear selection. Lift and hold the latch whilst moving to the required position.

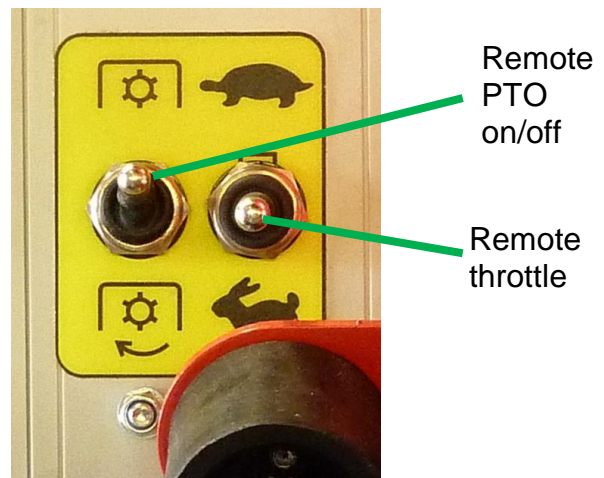

Remote hand throttle

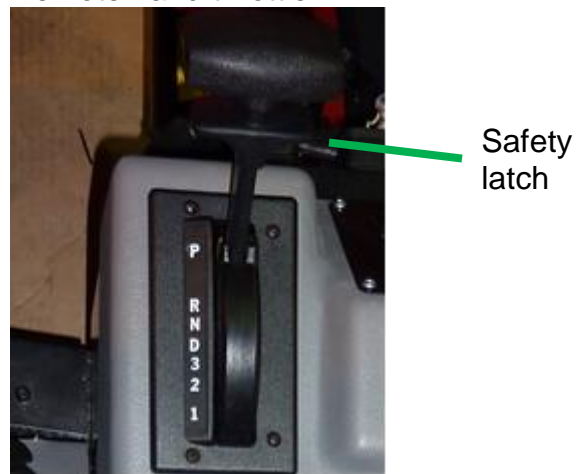

Auto gear shift

Operating - Gearbox

'P' - Park In this position the transmission is locked to prevent the vehicle from rolling away. Select **ONLY** with the vehicle stationary and the handbrake on.

'R' - Reverse Select **ONLY** when the vehicle is stationary

'N' - Neutral Use this position when the vehicle is stationary and the engine is to idle for a prolonged period (eg. at traffic lights)

'D' - Drive Select 'Drive' for all normal driving on the road; fully automatic gear changing occurs on all four forward gears according to vehicle speed and accelerator position

'3' - 1st, 2nd & 3rd gears Automatic gearchanging is limited to first, second and third gears only. Use for field work in good operating conditions with low pressure tyres fitted.

2' - 1st and 2nd gears Automatic gearchanging is limited to first and second gears only. Use for field work in more demanding conditions and when fitted with row crop wheels. In good conditions where your forward speed is relatively low or where you only have a light load you may need to use this position to stop the gearbox changing up to third gear. Although the engine/transmission may be perfectly happy in the higher gear you may find the engine speed is too low for you to attain the required PTO speed.

'1' - 1st gear only **Use at all times for steep hillside work where engine braking is required.** If you are changing down from second to first it is most important that you slow down enough to ensure that first gear is correctly selected. ***The gearbox has its own built-in protection system so if your forward speed is too high it will not change down automatically until the speed has reduced. Always leave the vehicle with the gear selector in 'P' (Park) position when parked.***

Starting & driving

Drivers unfamiliar with the performance characteristics of an automatic gearbox should thoroughly familiarize themselves with the following instructions before driving:

- Before starting the engine, ensure that both foot brake and handbrake are applied.
- After starting the engine, keep both brakes applied before and whilst moving the selector lever to the required drive position.
- Keep the brakes applied until you are ready to move - remember, once a drive position is selected, an 'automatic' will tend to creep forwards (or backwards).
- Never 'rev' the engine while selecting a forward or reverse gear, or while the vehicle is stationary with a drive gear selected - remember, an 'automatic' will move immediately the accelerator pedal is pressed

Gear change speeds

With 'D' selected, the speed at which gear changes take place will vary according to the position of the accelerator: minimum acceleration will result in low speed gear changes, while larger throttle openings will cause the gearbox to delay gear changes until faster speeds have been reached.

With practice, gear changes can be made to occur at a wide range of speeds depending on accelerator pedal pressure.

On long inclines and in some working conditions, the gearbox will change back and forth between gears. Under these conditions it is advisable to change down to the next lower gear to stop it 'hunting'.

Kick-down

To provide extra power and acceleration through tough spots, push the accelerator pedal to the full extent of its travel in a single quick movement (known as kick-down). Up to a certain speed this will cause an immediate downshift into the lowest appropriate gear. Once the pedal is relaxed normal gear changing will resume.

Transmission oil temperature

A temperature warning lamp is fitted in the dashboard to warn of excess oil temperature. Should the lamp illuminate you should **stop immediately and investigate the cause.**

Common causes are low transmission oil level and/or oil cooler radiator blocked with dust and chaff. Prolonged hard work on long inclines on hot days may also cause a problem - if you find this a problem in your particular working conditions please consult the manufacturer.

Operating - Transfer gearbox

Transfer gearbox

The second gearbox (known as the transfer gearbox) is used to select either the high or low gear range.

The low range should be used for all field work regardless of the wheels fitted.

High range should be used for road work only and allows a relatively high road speed to be used at relatively low engine revs (depending on ratios fitted).

The maximum road speed of 30mph (50kph) should never be exceeded - If you attempt to exceed this speed an audible warning buzzer will sound and the speed meter will flash. An engine cut-out will also come into effect just above the maximum permissible speed.

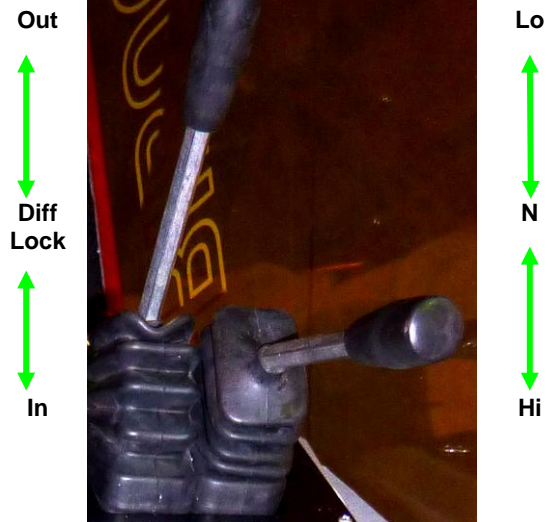

For some countries the machine may be governed down to a lower speed and transfer box locked in low range.

Changing range

The easiest way to change range is whilst moving **very slowly** on a hard roadway. Whilst slowing down to stop (**below 2 mph**) release the accelerator, select 'N' and move the transfer lever quickly to the required position. Reselect 'D' with the main gear selector and continue driving. *After a little practice, this operation can be carried out smoothly and quickly by using firm, positive moves.*

Differential lock

The transfer gearbox is fitted with a lockable centre differential. With the differential locked, the drive shafts to the front and rear axles are (in effect) joined together, causing both to rotate at the same speed. This feature enhances traction when working in difficult and slippery conditions and when working on steep hillsides. With the differential unlocked for normal conditions and roadwork, the different running requirements of the two axles can be accommodated, thereby enabling the Agribuggy to operate permanently in four wheel drive for both road and field work.

When to use the diff lock

As a general rule, the differential should only be locked on slippery or loose surfaces or on very steep hillsides. If excess wheel slip is evident then it should, of course be used. However **do not** use it unnecessarily. **It must be disengaged for all road work.**

Selecting diff lock

The diff lock can be engaged or disengaged either with the vehicle stationary, or when driving along. However, with the vehicle in motion it is essential to be travelling on firm ground, in a straight line and without wheel slip. Do not engage the diff lock if one or more wheels are slipping - this could result in serious transmission damage. If wheels are slipping, ease off the accelerator before engaging the diff lock.

Engaging diff lock - Move the lever backwards - the warning lamp will illuminate when the differential engages. NB The lamp will only light up when the lock is actually engaged - rather than when it has been selected. Similarly it will only extinguish when the diff is actually disengaged.

Dis-engaging diff lock - Move the lever forwards. If the warning light is obviously reluctant to extinguish after the diff lock has disengaged, some transmission 'windup' may be present. Reversing the vehicle for a short distance and then going forward will usually 'unwind' the transmission.

Operating - Foot brakes

Braking system

As a safety precaution, the hydraulic braking system operates through dual circuits. If one circuit should fail, the other will continue to function, but increased pedal travel and longer stopping distances will be experienced.

A warning light on the dashboard (see page 9) will warn you of low brake fluid

The braking system is hydraulic servo assisted, but **ONLY** when the engine is running. Without this assistance greater braking effort is necessary to safely control the vehicle, resulting in longer stopping distances. Always observe the following precautions:

- Never allow the vehicle to freewheel with the engine turned off (the steering will also be affected)
- Take particular care if the vehicle is being towed
- If the engine should stop for any reason whilst the vehicle is in motion, bring the vehicle to a halt as quickly as traffic conditions allow.

Remember! regular servicing is vital to ensure that the brake pads are examined for wear (especially when working in wet/muddy conditions) and changed periodically to ensure long term safety and optimum performance. When new brake pads have been fitted you should allow a period of time for them to "bed in" before optimum braking is achieved.

Driver's seat. The driver's seat is fully adjustable as shown.

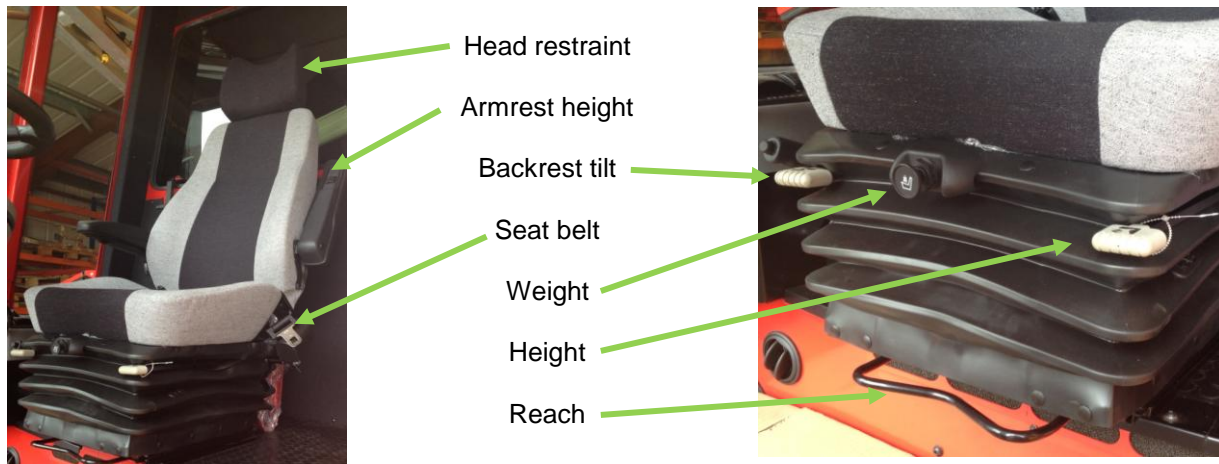

Agribuggy RDS Monitor

Engine / PTO speed / shaft speed / ground speed

These functions are all displayed on the Agribuggy RDS monitor (see separate manual).

These functions also have their own warning systems built in to protect the machine from speed, engine and PTO over-speeding. The four wheel steer warning system is also operated by the monitor. For this reason it is important that the monitor is not removed from the cab and **must be working and switched on** at all times.

Instrumentation

The remaining instruments and warning lights on the steering column that have not already been mentioned are self-explanatory (see page 9). Should any of the warning lights illuminate whilst the machine is running **it must be stopped immediately and the cause investigated.**

Operating - Hydraulic PTO

Hydraulic PTO system

For information on the optional high power PTO system (Airtec) or non standard hydraulic systems please see appendices.

Safety

- **Ensure PTO is disengaged before starting engine.**
- **The engine MUST be switched off before connecting the PTO or making adjustments.**

Operation

The PTO is hydraulically driven, is fully independent and may therefore be engaged at any time providing the engine revs are not too high. The PTO is controlled by the main RDS monitor.

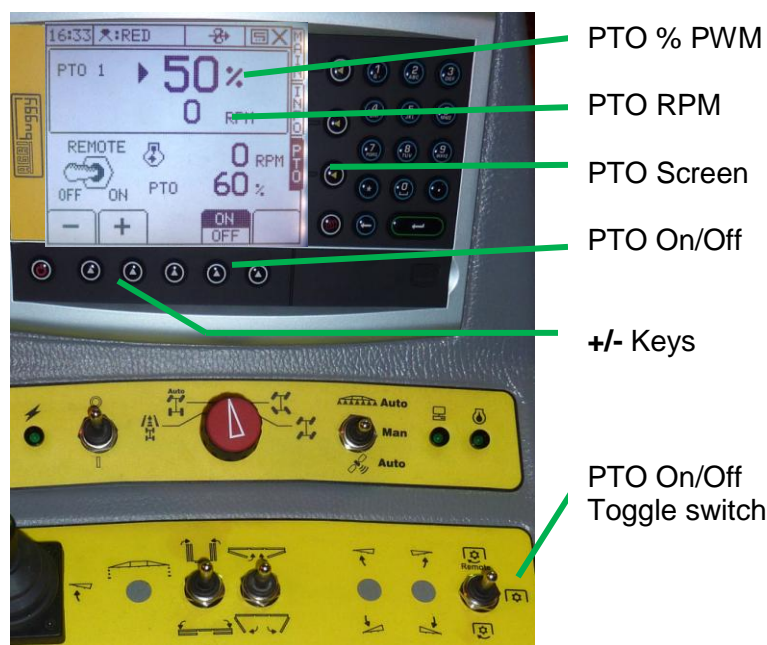

To Engage & Set PTO speed

To engage the PTO select PTO screen on the RDS Monitor and select ON (RH-side bottom of screen) and then select the toggle switch on the panel below. The hydraulic pump is geared so that 540 r.p.m. on the PTO is reached at a minimum engine speed of approx 1800 rpm. To set the PTO for 540, or indeed any other required speed, increase the engine speed to approx. 2000 rpm and adjust the speed with the +/- keys to set the PWM %, with the PTO engaged the speed will be indicated on the screen just below the % PWM.

Once the speed is set, if the engine rpm is increased there will not be a significant increase in PTO speed. The PTO speed should never exceed 600 rpm. For most spraying operations you will find it is not necessary to

Trip-tronic / Throttle / Cruise control

always run the PTO at 540 rpm. Lower PTO speeds result in reduced wear and tear in the spray pump and hydraulic system, a lower engine power requirement and can help to prevent foaming in the spray tank.

If the sprayer is fitted with a high capacity spray pump e.g. 250 l.p.m. or above, the PTO speed should be set as low as possible whilst spraying. Speeds in the order of 350 rpm to 450 rpm are normally more than adequate to achieve working pressure with excess flow left for agitation. Higher speeds may result in overheating of the hydraulic system.

A remote PTO function is available for use when quick- refilling the spray tank

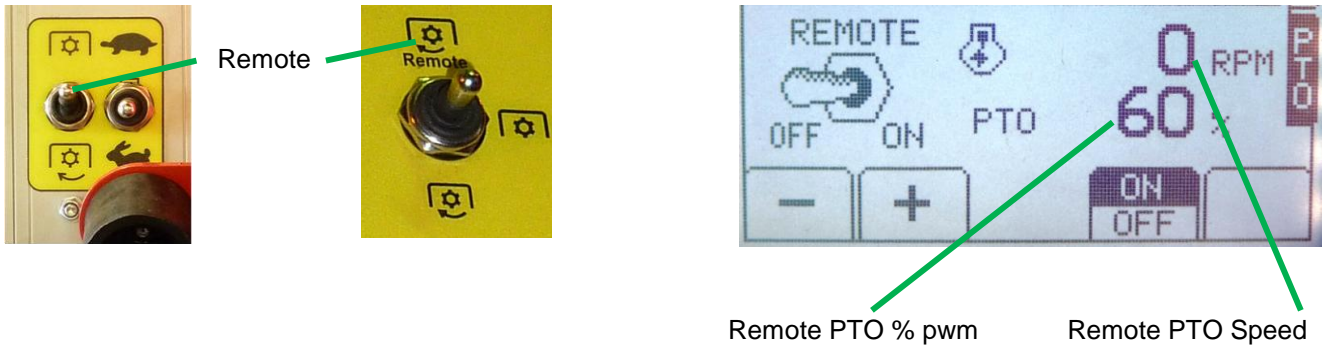

The desired remote speed is preprogrammed into the RDS Monitor as a % pwm. To set, Switch the dashboard and external PTO toggle (fitted next to the clothing locker) switches to the remote on positions. With PTO menu selected on the monitor (remote switch image should show 'on') use the +/- keys to select the desired pwm%. / The speed can be adjusted by either the "Set/+" or "Res/-" buttons or by the toggle switch next to the clothing locker. The speed is stored in memory for use next time

It is important to ensure that sprayer filters are kept clean and self-cleaning filters are working correctly at all times. Failure to do so will result in loss of PTO speed and overheating of the hydraulic system.

Tip-tronic / Throttle / Cruise control



Trip-tronic



Enable/Disable - With the gear shifter in the "D" (drive) position, press and hold the "M" (manual) button for 1 second to enable the Tip-tronic function. Press and hold again to disable.



Bump up/down - To change up and down through the gears manually press either the "+" or "-" buttons. Please note the transmission has a self-protect feature and it will only allow you to upshift or downshift if the engine and ground speed is within operating limits.

Cruise / Hand throttle control

Cruise / Hand throttle

There are two methods of controlling the engine/ground speed – the hand throttle or the ground speed related cruise control.

Hand throttle

The hand throttle mimics the output of the throttle pedal – this can be used when the vehicle is either stationary or whilst travelling. In this mode the engine speed is not fully governed so the speed will vary if the load on the engine varies – just like it does when using the foot throttle. It is useful when stationary for holding the engine at a fixed speed - for example when filling the sprayer. It may also be better than the cruise control function in the field when working on flat ground in easy going conditions.

Cruise control

The cruise control can only be used when moving above approximately 5 km/h. In very easy going conditions some “hunting” may occur and it may be easier to use the hand throttle. In heavy or undulating field conditions the response may not be quick enough and the foot throttle will give the best control.

Operation

The controls for both the hand throttle and the cruise work in the exactly the same way with a different button being used to activate each one. Once one system is activated the other cannot be enabled until the first is deactivated.



Throttle **Cruise**

Activate / De-activate / Suspend / Reset- Press and hold for 2 seconds to enable. (NB only one of these functions can be used at any one time). The button will illuminate to show the system is active. Press and hold for 2 seconds to disable. Tap to suspend or press and hold for 1 second to reset – the lamp will flash after one second to indicate that the speed has been reset.

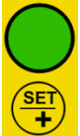

Set - To set the required speed hold the foot throttle at the required engine or ground speed and then press the “**Set**” button. Remove foot from throttle. The speed can be overridden by depressing the throttle pedal, when the pedal is released it will resume the pre-set speed. To suspend automatic control either depress the brake pedal or tap the “**Activate/reset**” button. If the 4WS is set to “**Auto**” mode then switching the sprayer off will also suspend the cruise. To reset the speed to zero press and hold the “**Activate/Reset**” button for 1 second



Resume – After the speed control has been suspended the previously set speed can be resumed by tapping the “**Res**” button”. The speed can be resumed whether the sprayer is switched on or off.

When using cruise control in the field and resuming the set speed after a headland turn press “**Res**” and let the system accelerate back up to working speed .

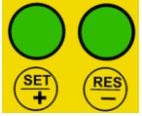

Increase decrease speed – Whilst the speed is being controlled automatically it can be bumped up or down by either tapping or holding down the “**Set/+**” or “**Res/-**” buttons. These buttons can also be used to adjust the engine speed when the remote PTO switch is switched on.

Operating - Hydraulics / Air conditioning

Spool valves

Electro-hydraulic spool valves are fitted to operate the boom's, these are controlled using the 4-way "Joystick" for lift/lower and tilt, and the two toggle switches for inner and outer folding, all located on the main console. The decals behind each switch indicates it's function for boom folding. There are normally 4 services fitted which can be any combination of single and double acting spools. A double acting spool can be safely used to operate a single acting service if required.

The hydraulic system/spool valve(s) fitted are only designed for intermittent operation of hydraulic cylinders and **should not be used to power motors or other hydraulic circuits**. Maximum pressure at the spools is approx. 2300 psi (160bar) Please consult the manufacturer if you require higher pressures or if wish to use them for any other purpose.

Please ensure that all couplings are clean before connecting hoses and that any couplings that are not in use are protected with plugs / caps. Ingress of dirt into the hydraulic system can lead to premature wear and possible failure of major components.

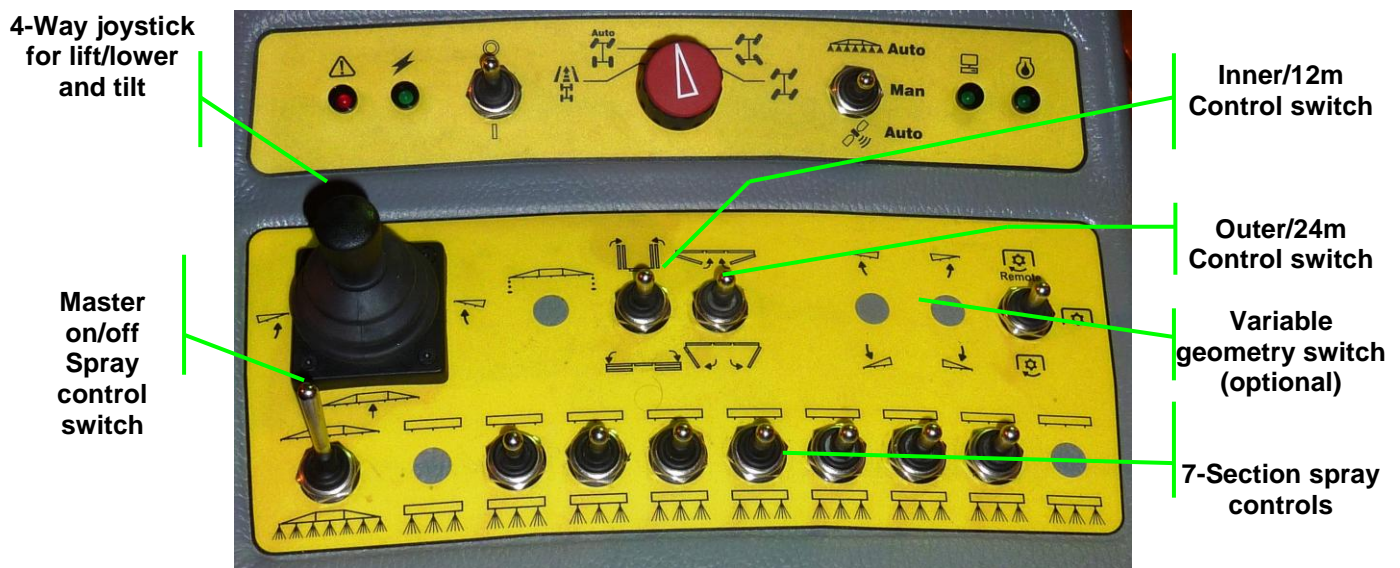

Air Conditioning / ventilation

The air conditioning unit is installed in the cab roof. The unit will cool the air which may be drawn in to the cab through a carbon filter or re-circulated within the cab. **When applying chemicals it is important that some air be drawn into the cab at all times to ensure that it is kept positively pressurised to keep dust and vapors out.**

Operation

To operate the fan, turn the LH switch in the panel clockwise until you find the most preferred of the three speeds. The adjustable vents in the roof panel can be directed to wherever you require the air.

To reduce the temperature of the air, turn the RH switch clockwise until the cab temperature is reduced as required. For maximum efficiency the heater should be turned fully off. Always keep the cab door and rear window closed to keep the cab cool.

The heater is separate from the air conditioning system, the heater controls are on the right-hand console adjacent to the Automatic gearbox control lever. To increase the temperature of the air turn the LH switch clockwise to control the fan select one of the three fan speeds by rotating the RH switch to the desired setting. N.B. The air conditioner temperature control should be turned anti-clockwise.

Operating - Cab ventilation

Demisting

In damp conditions the heater control can be used in conjunction with the chiller to dehumidify the air entering the cab - to demist quickly turn both controls fully clockwise. For demisting on cool damp days turn the chiller control to the minimum setting, the heater to maximum and the fan to the second speed.



Air conditioning console



Heater control

Emergency exit

In the case of an emergency where the door can't be opened the two pins securing the rear window fasteners can be removed and the rear window used as an escape hatch.

Remove pin



Operating - Field operation

Row crop work.

Only row crop wheels recommended by the manufacturer should be fitted to the Agribuggy. Fitting any other wheels will invalidate the warranty and could make the machine un-safe!

Wheel track should not exceed 78" without consulting the manufacturer. The top road speed is increased significantly when row-crops are fitted, however, **a top speed of 30 m.p.h. (50 kph) should still NOT be exceeded. Speeds over 20 mph (32 kph) should only be used if the tyres fitted are suitable.**

Please read notes on steering stop adjustment if you are fitting row crops on a Agribuggy with a wheel track of less than 68". The stops may have to be altered to maintain adequate wheel/cab clearances. It is also advisable to service the brakes as a matter of course before fitting row crop wheels in the Spring.

It is recommended that the front crop deflector and underbelly crop sheet be fitted when working in tall crops particularly as harvest approaches. This not only reduces crop damage but also protects the underside of the machine and stops the crop being pulled into the drive belts, shafts and alternator etc.

The front mounted crop deflector also helps to prevent the radiator from blocking. It may have to be extended for use in oil seed rape and some other tall crops. If so please ensure that the extension does not restrict the air flow into the radiator, especially when being used on the road.

Field Operation

The optimum working speed of the Agribuggy in reasonable conditions is 6-9 mph. (10-14 kph) This speed is normally achieved in second gear for 7.5 mph (12 kph). If conditions are good, you may be able to travel in third gear as long as the engine is not labouring.

Try to keep between 1700 and 2800 rpm. Slow down and select a lower gear if necessary.

High engine revs will result in higher engine temperatures and fuel consumption.

The suspension of the Agribuggy gives it a relatively smooth ride compared with a tractor, however, it should still be driven with care and respect especially over rough ground.

Should you get badly "bogged down" when working in wet conditions, ensure that mud has not been forced up into the crankshaft pulley / drive belt area. If it has, then thoroughly clean the area.

Field planning.

Try to plan your field before you start work. You will soon find out what the Agribuggy is capable of. If a field has any particularly wet areas or steep banks, plan the field so that your load is reduced before you reach them. If it has a very steep hill in it, it is advisable to reduce your working speed to 6 mph to do the whole field. 1st and 2nd gear can then be used. When spraying at relatively high speeds, it is very important that your working speed is maintained to avoid over or under dosing. For this reason it is important that two 12 metre bouts are sprayed around the headland before spraying the rest of the field. When spraying the rest of the field maintain your speed as you travel onto the headland and do not start to turn until the sprayer is switched off. After turning, straighten up, and aim to get up to your target speed before switching back on.

When spraying with a wide boom do not change direction suddenly particularly when in 4WS mode or severe under/over dosing will occur as well as passing high shock loads on to the spray boom. Use 2WS mode whilst spraying down the field and try to turn as smoothly as possible at the ends.

Operating - Speed / fertiliser spreading

Potatoes.

When spraying potatoes with row crop wheels fitted it is most important that care is taken when turning. If a dummy headland is left between the field rows and the headland rows you may find it necessary to shunt when turning to avoid crossing over the headland rows. Go as slow as possible (bottom gear) if turning over the rows is unavoidable to ensure unnecessary strain on the machine is kept to a minimum.

Sugar Beet.

When spraying sugar beet you will find it best to look forwards and drive by the centre of the machine rather than trying to look down at the wheels. Fit a centre marker on the bonnet if necessary. For low-dose/high pressure spraying forward speed should not exceed 6 mph (10 kph).

Choice of jets.

We recommend the use of 110 degree fan nozzles for general high speed spraying. These will give better coverage than 80 degree jets with a more appropriate droplet size. Twin outlet or twin jet caps will give even better coverage. However, you should always check on your chemical container for recommendations regarding forward speed, pressure, spray quality and water rates before choosing which nozzles to use.

Forward speed

Most spraying operations can be carried out at 7.5 mph (12 kph), however the following points should be taken into consideration: The spray boom should ride evenly and should not bounce and yaw about - an unstable boom is one of the main causes of uneven application. If the crop is particularly dense or tall and good penetration is essential reduce your speed to 6 mph (10 kph). Also remember that, increasing pressure does not increase penetration - It simply increases the number of smaller droplets which will settle on the upper leaves or blow away. If conditions are particularly rough, even if the boom is stable, it may pay to reduce speed for the sake of the machine.

Fertiliser spreading.

Kellands Agricultural can provide purpose made mounting frames to suit a range of spreaders. If you wish to fit a spreader to the Agribuggy, contact kellands to ensure compatibility both in terms of fit and hydraulic requirements.

When fitting a spreader it is imperative to protect the chassis by avoiding fertilizer being thrown forwards onto the machine, a suitable sheet should be fitted across the front of the spreader for this purpose. **Please remember the warranty does not cover faults caused by corrosion!**

Service & Warranty.

The Agribuggy carries a 12 month / 1,000 hour warranty (whichever occurs first) on defective parts and workmanship. It does not cover faults caused by incorrect use and servicing or faults caused by fertiliser or chemical corrosion.

All servicing should be carried out as per this instruction manual particularly during the warranty period. The first service is normally carried out by the customer after the first fifty hours running. If any faults are apparent on delivery, at this first service or during the warranty period Kellands Agricultural would appreciate notification as soon as possible, even if the fault is rectified by the customer. Kellands Agricultural understand that many customers will repair straight-forward faults themselves without reporting them, however Kellands policy is one of continual improvement and with co-operation and any suggestions and ideas, product enhancements can be made to the mutual advantage of customer and supplier.

If any problems occur with the machine please contact Kellands Agricultural, without delay, with whom you can discuss the best way to deal with the problem to avoid unnecessary delays. If a repair is carried out by the customer or by an outside engineer to save time, and it is wished to claim costs under warranty, Kellands must be notified first or the claim will not be accepted under any circumstances. Unauthorised repairs may affect or even invalidate any remaining warranty. Any parts replaced must be returned to us for assessment.

If Kellands service engineers are called out at any time, to work on the machine or if the machine has to be returned to their works for repair, it must be thoroughly cleaned to remove all chemical and fertiliser residues to enable the work to be carried out safely and effectively. If the machine is not clean, they reserve the right to either refuse to carry out the work or to charge for cleaning.

Maintenance & Technical information

Daily maintenance points – engine

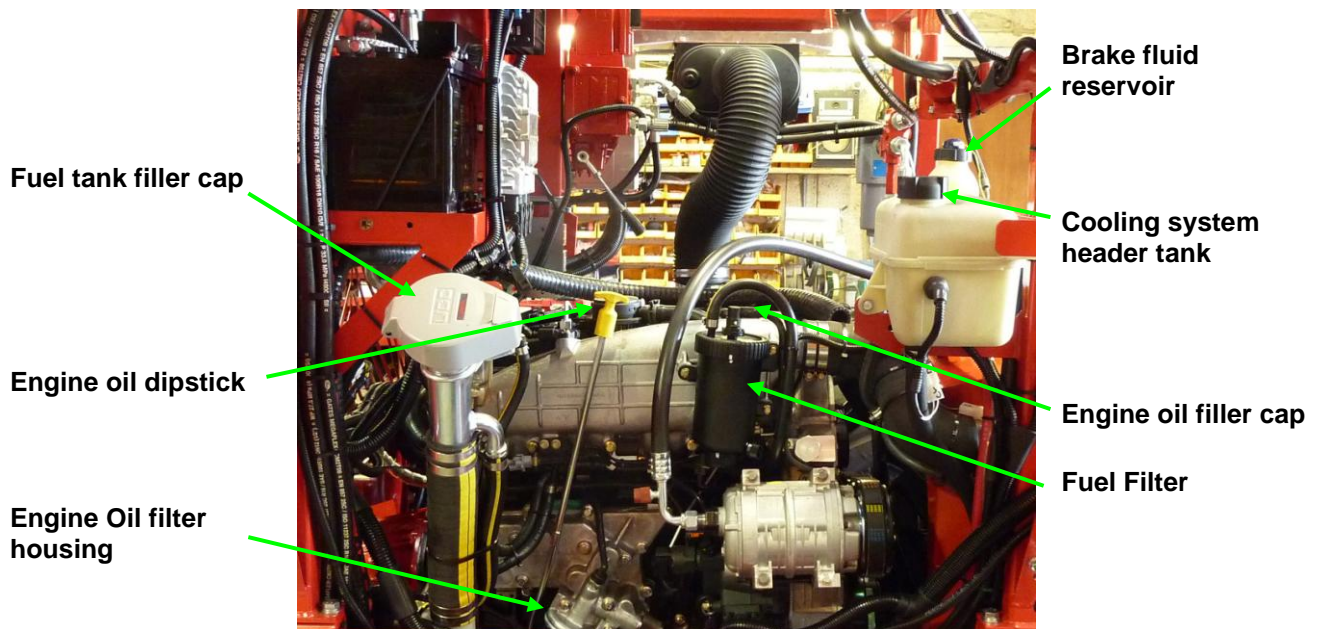

Maintenance and technical information.

The life of the Agribuggy will depend on the care it receives throughout its life. It is the operator's responsibility to ensure that the machine is correctly operated and that the maintenance operations outlined in this manual are carried out regularly after the specified hours of operation are reached. If you are unsure of how to carry out any of the maintenance operations please do not hesitate to enlist the help of Kellands Agricultural.

Please remember that the Agribuggy is unlike a tractor in many ways and the standard of maintenance needs to be much higher. It is designed primarily as a light weight machine and so consequently the components used in its construction have to be lightweight and are often of automotive origin. These parts will generally last just as long as heavy duty components providing they are inspected, serviced and maintained regularly. The Agribuggy is fitted with suspension and a rubber mounted engine so consequently not only are the drive line components more open to the elements but there are more moving parts which are also more subject to wear and tear. Engine hoses, cables and wiring looms are also more susceptible to wear and tear and also need regular inspection. Finally the machine is much more susceptible to general corrosion, seizure of components and electrical problems than a tractor due to the mounting position of the sprayer and fertiliser spreaders - right on top of it!

When carrying out your weekly service it is well worth spending a little time looking over (and under!) the machine and checking the condition of hoses, wear on drive shafts and for any signs of chafing or things coming loose. Also take the opportunity to go round with the oil can and lubricate anything that moves - particularly when working with fertilisers. An hour a week can save expensive down-time later on.

All nuts and bolts should be checked for tightness after the first day's operation, **especially axle u-bolts, wheel nuts, steering joints and track rod ends and propeller shaft bolts**. Check engine and hoses for fluid leaks regularly during the first few days of operation.

Please refer to the condensed maintenance guide for service intervals.

Engine oil

Checking oil

Check oil level daily ensuring that the Agribuggy is standing on level ground. Use SAE 10W/40 Semi-synthetic multi-grade oil with the following specifications:

ACEA E3/CG4

(6.6 litres inc filter, 5.5 litres sump only)

The use of universal tractor oil is **not recommended** as they generally do not meet the required specification and will lead to premature wear.



Dipstick

Oil Filler Cap



Check the oil when the engine is hot and with the vehicle on level ground.

Allow the engine to stand for 5 minutes to allow the oil to drain back into the sump.

Withdraw dipstick and wipe clean.

Fully reinsert dipstick and withdraw to check level.

The level should NEVER be allowed to fall below the bottom level mark on the dipstick.

Do not fill above 'Max' mark on dipstick

Maintenance - Changing engine Oil

NB If it is necessary to check the oil whilst the engine is cold, DO NOT start the engine. Follow the procedure as above and re-check the oil level once the engine has reached working temperature.

As a general guide if the level is nearer to the upper mark than the lower one then add no oil
If it is nearer the bottom mark than the top one add half a litre.
If it is on the bottom mark or below it add one litre of oil.

Changing oil and filter

1. Warm engine to normal operating temperature.
2. Make sure machine is stood on level ground, stop engine and turn battery isolator off.
3. Remove oil filler cap from rocker cover, place suitable draining tray under engine and remove drain plug from oil pan.
4. Using a suitable strap wrench, unscrew the oil filter canister one complete turn.
5. Position a suitable draining tray underneath the filter and remove the filter from the engine casting by hand. Discard the old filter canister.
6. Thoroughly clean the oil filter housing face.
7. Partly pre-fill the new filter with clean oil of the correct type. Apply a thin film of clean oil to the filter sealing ring.
8. Screw on new filter until sealing ring abuts the filter head and tighten a further 1/2 turn.
DO NOT OVERTIGHTEN.
9. Replace sump drain plug and fill engine via filler neck in rocker cover. Total oil capacity (inc. filter) is 6.6 litres.
NB A funnel will be required for filling oil through the rocker cover filler neck.
10. Replace oil filler cap, run engine and check for any leaks from the oil filter.
11. Stop engine, allow oil to settle, check and top up as necessary.
DO NOT OVERFILL



Sump oil drain plug

Oil filter



Drive belts

This engine uses a 'serpentine' type drive belt, which drives all the ancillaries except for the hydraulic pump.

An automatic belt tensioner keeps the belt at the correct tension, thereby eliminating the need to manually check the belt tension.

The belt and all pulleys should be examined regularly for any damage, deterioration or fouling with mud, grit or chaff etc.

Under normal use the belt should be changed every 1,000 hrs or every 2yrs but in adverse conditions it may need changing at 500hrs or less.

Before checking, turn off the battery isolator switch to prevent the engine from being started

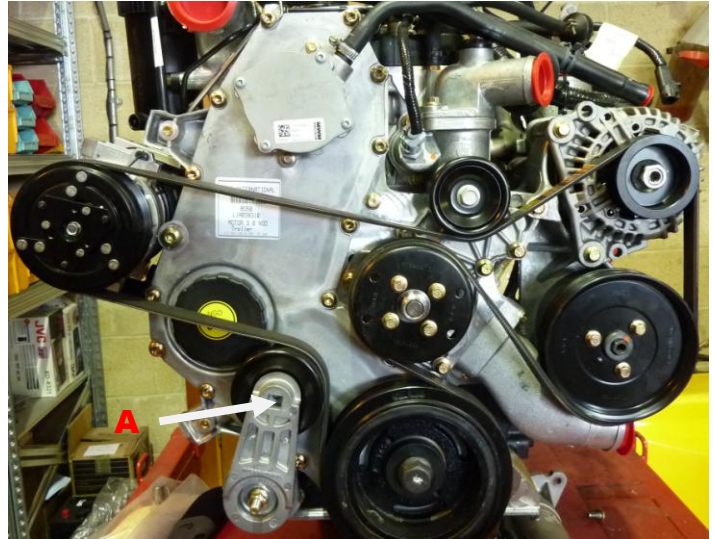

Replacing drive belt

1. Remove hydraulic pump drive belt. (see over)
 2. Fit a 15mm ring spanner on to the tensioning pulley centre bolt (A above right) and turn anti-clockwise to release tension.
 3. Remove belt and release tension gently.
 4. Check all pulley grooves for wear and cleanliness.
 5. Turn tensioner anti-clockwise again and fit new belt.
 6. Inspect/replace hydraulic pump drive belt
-

Maintenance - Pump drive

Hydraulic pump drive

The hydraulic pump is driven by a toothed belt from the engine crankshaft.

The belt tension and the belt and pulley condition should be checked periodically and replaced if necessary.

The belt can be removed by slackening off the four pump mounting bolts and sliding the pump towards the engine.

DO NOT OVER TENSION THE BELT

When tensioning the belt a lever may be inserted into one of the mounting bolt slots - however take care not to overtighten the belt or damage to the pump bearings may result. The belt is tensioned correctly when it can be twisted 90° by hand.

It is important that only genuine replacement belts be used - There are various belts available that may fit but they all have different power ratings - an incorrect belt will lead to excessive wear on both belts and pulleys.

Cooling fan

The cooling fan has a viscous coupling which does not require any maintenance. It can be removed from the end of its drive stub to facilitate removal of the fan cowling and radiator or for radiator cleaning and belt replacement.

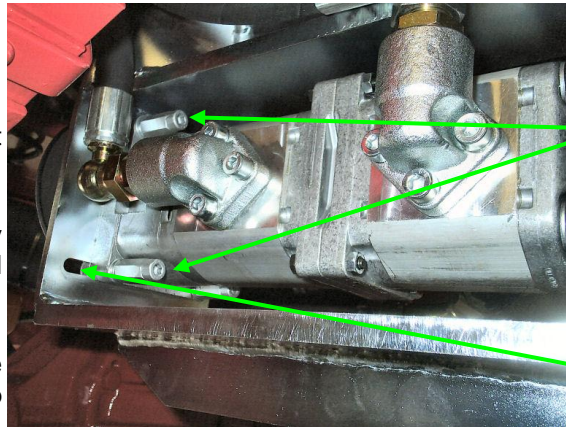

Pump mounting bolts

Adjusting slots

Grease nipple

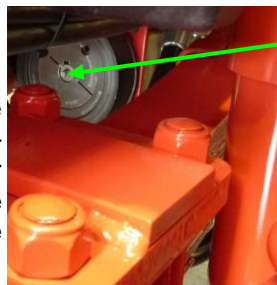

Cooling system

The coolant level is visible through the transparent walls of the degas tank. The coolant should be level with the 'Max' mark when the engine is cold. DO NOT OVERFILL. Allow engine to cool down until the back of the hand can be held against the cylinder head without discomfort before removing cap. Only turn the cap to the first stop, so that pressure in the system is released. Then wait a few seconds before removing the cap completely.

Never use cold water to top-up the cooling system of a hot engine, particularly if the coolant level is very low. This could cause serious damage to the engine.

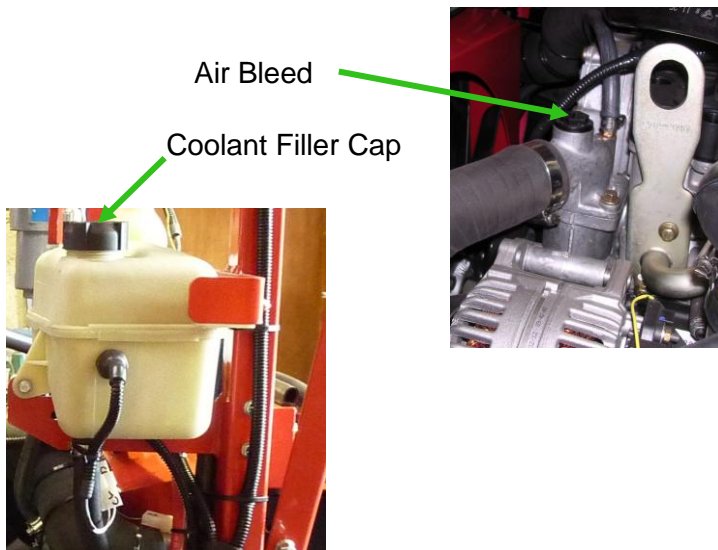

The system should only be topped up with a water / anti-freeze mix as specified below.

Ensure that the pressure cap is re-tightened correctly before running engine.

After two years the cooling system must be flushed out and coolant replaced. When the coolant is replaced or if a high quantity of coolant has to be used for topping up then care must be taken to ensure the system is free from air. To do this remove the air bleed plug and add coolant through the degas tank until it can be seen that the top hose and radiator are completely full. Re-fit the plug and top up to the correct level. The engine should then be run (with the cab heater turned on) until it reaches normal working temperature and then switched off and allowed to cool and the water level re-checked.

If the system is completely drained it is also necessary to remove the engine air bleed plug in the thermostat housing when re-filling the system. (see above)

Coolant capacity is approximately 3.1/3 gal (15 litre). It is recommended that you use LandRover pre-mixed antifreeze (particularly if you are in a hard water area) or a proprietary ethylene glycol based antifreeze (containing no methanol) with non-phosphate corrosion inhibitors suitable for use in aluminium engines. Use one part anti-freeze to one part water for protection down to -33°C Please check with your supplier that the antifreeze you use meets this specification to ensure full warranty cover.

A fine mesh screen is fitted in front of the cab air intake grill and should be kept clean at all times. It can be cleaned by brushing lightly or blowing out with an airline.

Ensure the cab lower side panels together with their respective sealing rubbers are correctly fitted at all times - they ensure only clean air can be pulled through the inlet grill to the radiator.

Ensure that the radiator cores are also kept clean - inspect it regularly but take care if using a pressure washer to clean it - it is very easy to flatten the fins which will reduce air flow through it.

For late season spraying it is recommended that the optional crop deflector be fitted to the front of the Agribuggy to not only reduce crop damage but also to avoid blocking of the radiator grill/screen with pollen etc.

Maintenance - Fuel system

Fuel system

It is particularly important to keep the fuel system well maintained - If even only slight traces of contamination or water are allowed to get past the filtration system and into the injection pump, the engine performance will be seriously affected and serious damage will be caused to the pump.

Fuel tank

The fuel tank holds approx. 19 gals (86 litres). Use clean diesel fuel only. Always fill the tank at the end of the days work to avoid condensation. Drain the diesel tank periodically. (At least every 300 hrs) Take care to ensure the cap is correctly closed after filling and when washing off do not direct a pressure washer directly at or under the filler/breather.

Draining fuel filter

The primary fuel filter unit should be drained regularly (every 50 hrs). To do so slacken the plug underneath the filter assembly to allow any accumulated water to drain from the filter.

Replacing primary fuel filter element

1. Ensure filter head area is clean.
2. Drain fuel from fuel filter.
3. Using spanner, unscrew the centre bolt on the filter head and release the element and bowl.
4. Fit new seals (usually supplied with a new element) in the head and bowl, locate the new element in the bowl and reposition under the head. Screw in the centre bolt and tighten
5. Ensure the drain plug at the base of the filter is closed.
6. Recharge the filter with diesel by slackening the bleed nipple and pumping the lift pump on the filter head until fuel flows freely. Retighten the bleed nipple when complete.

Water/sediment trap

A water trap/sediment bowl is fitted in the suction line between the primary and secondary fuel filters. The glass bowl should be checked weekly for any signs of water or sediments. The glass bowl should be removed, emptied and the internal filter cleaned **before** it gets half full of water. When replacing the bowl take care not to over-tighten the thumbscrew.

Secondary Filter

Unscrew cap to access the element

Note: Environmental care should be taken at every stage of this process, catch any fuel released in a suitable container and dispose of as required.

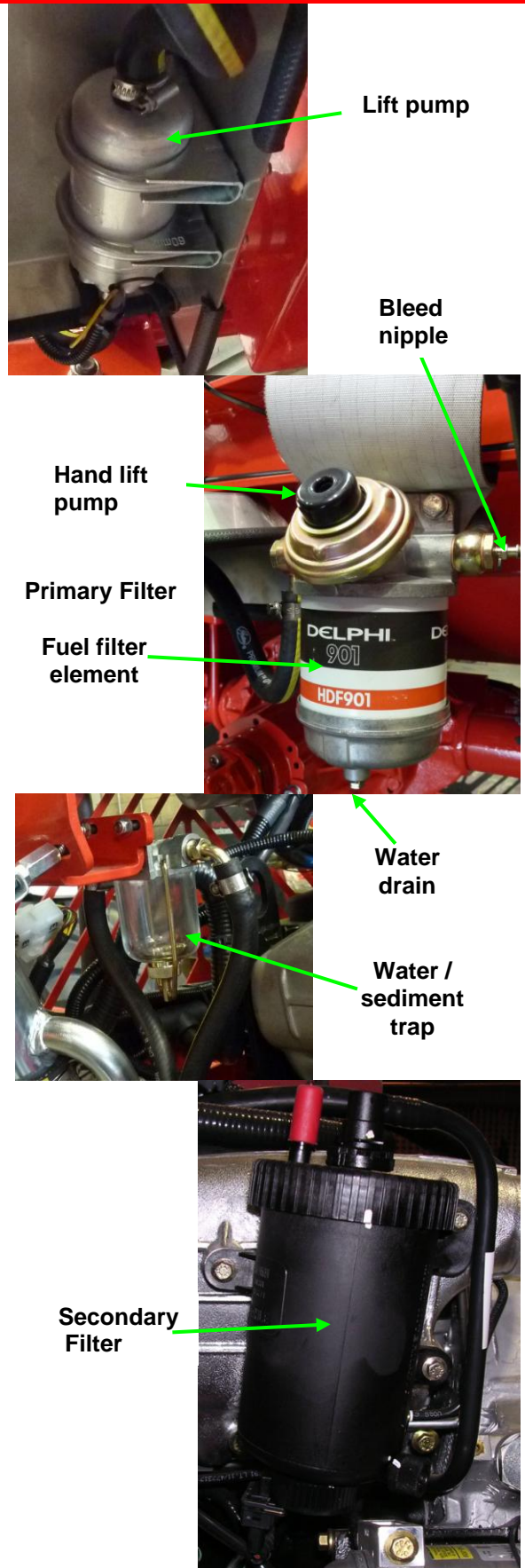

Bleeding the fuel system

The injection pump on this engine is self priming, however, should you change the filter or run out of fuel, the system may need bleeding as far as the fuel filter. A hand pump is fitted to the filter head for this purpose. (See above)

1. Slacken off the bleed screw on top of the fuel filter.
2. Operate the lift pump repeatedly until air-free fuel flows from the filter outlet.
3. Tighten the bleed screw on top of the fuel filter.
4. Start the engine as normal but avoid turning the engine over continually for above 20 secs to avoid damage to the starter motor - it may take several attempts.

On no account should any of the injector pipes / fittings be slackened in the bleeding process.

Hydraulic system.

The standard hydraulic system develops a maximum of 6hp (at the PTO) Please consult the manufacturer if you wish to drive anything other than a conventional diaphragm sprayer pump.

Do not alter the relief valve settings on either the spool valve or flow divider without consulting the manufacturer. They are preset at: PTO flow control 2000 PSI, Spool valve relief valve 2250 PSI, Brakes 1000 psi, front steering 1700 PSI and rear steering 1800 PSI.

See appendices for information on uprated and non-standard hydraulic systems.

To access to the hydraulic oil filler cap remove the grill on the nose in front of the cab



Maintenance - Air cleaning

Hydraulic oil

Ensure the hydraulic system is kept clean. Be careful when refilling tank. Do not direct high pressure hose at filler/breather cap. Oil level should be kept to top of level/temperature gauge. Use good quality, clean hydraulic oil for topping up only (I.S.O VG 68). Do not use universal oils. The oil should always look clear and clean - If there are any signs at all of cloudiness or "milkiness" the oil should be changed.

Oil filter

Change return line filter when indicator on filter unit turns red or at least every 500 hours or 12 months whichever is sooner. If excessive oil contamination is evident the oil should also be changed and the suction filter (inside tank) should be removed and washed out. If this filter is removed ensure that no contamination gets inside the suction pipe or into the inside of the filter. **NB** some machines may be fitted with a pressure gauge instead of a red/green indicator. - Return line pressure should not exceed 20 p.s.i.

NB turn off isolator valve before removing filter. Remember to turn back on before running engine and fasten with cable ties as above right to avoid accidental moving

Air Cleaning System

A cyclone type air cleaner is fitted to the Agribuggy with a dry element. Under normal operating conditions it should be replaced every 500 hrs. In dusty conditions it should be replaced more regularly

When the air filter element does need servicing, replace it with a new one. Do not attempt to clean it. The condition of the air intake hoses should be checked regularly for signs of wear or damage and should be replaced if necessary.

Dump Valve

The dump valve is situated on the end of the filter housing (see right). Squeeze the valve open to release any accumulated particles every 50 hrs.

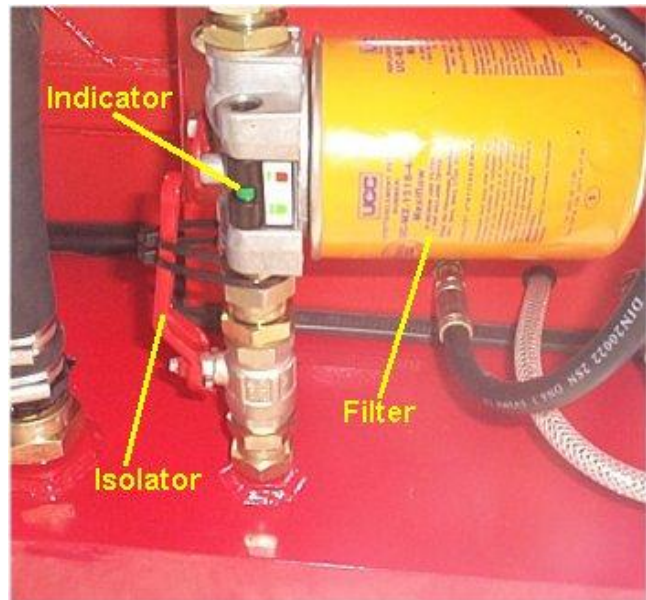

Retaining clips

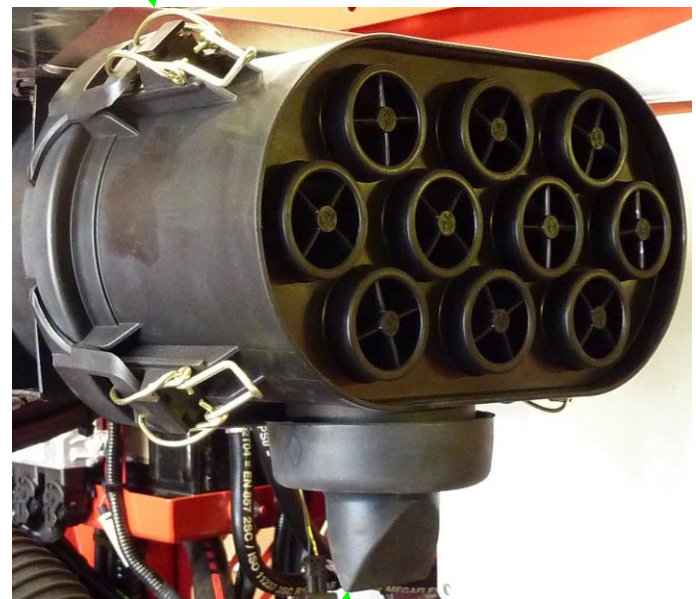

Dump valve

Screen Wash

The screen wash reservoir is situated in the noise in front of the cab, to access turn the fasteners to release the grill.

Cab Filtration Unit

The Agribuggy cab is fitted with an integrated air conditioning and carbon filtration system. The air inlet filter will filter out dust and small particles and the carbon element of the filter will filter out chemical particles and vapours. The carbon in the filter will only remain effective for up to a maximum of 6 months, whether the machine is being used or not, as the carbon degenerates when in contact with the air. If the machine is being used continuously it is recommended that the filter be changed every 300 hrs. If the machine is not being used for a long period of time, its life can be extended by removing the filter and storing it in a plastic bag.

Filter replacement

To access the filter release the two retaining screws securing the roof liner. The liner will hinge down. Release the six bolts securing the filter cassette whilst supporting its weight. Slide the cassette down and remove the filter. Place it in a plastic bag and dispose of properly. When fitting the replacement filter ensure that the rubber seal around the filter is located correctly to avoid contaminated air being pulled into the cab past the filter.



Filter

Air conditioning

With the exception of the recirculation air filter there are no user serviceable parts in the air conditioning system, the only regular maintenance being the servicing of the compressor drive belt - as described earlier in this manual. The clean or replace the recirculation filter, release the two thumb screws to access the filter.

It is recommended that the system is serviced annually by a qualified refrigeration engineer. The refrigerant gas currently being used is R134A at which time the receiver dryer and oil should be changed.

Maintenance - Gearbox, Electrical

Automatic transmission oil

The transmission fluid level should be checked at least every 50 hrs. It should be checked when the fluid is cold and with the engine **idling in neutral**.

Ensure the transmission fluid is kept to the level of the plug hole- **Do not overfill**

Use ATF Dexron IID for topping up - top up through the level hole.

The oil should be changed every 500 hrs. The oil, oil filter and oil filter screen in the bottom of the gearbox should be changed either by Kellands, your dealer or by a suitably qualified engineer every 1,000 hours.

Transmission fluid fill and level check point

Transmission Filter mounted on rear engine bulkhead

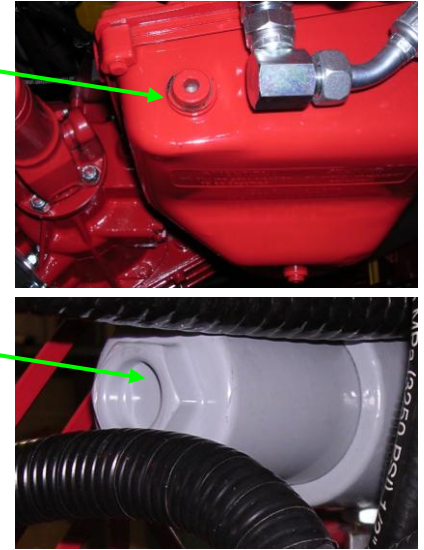

Transfer gearbox oil

The transfer gearbox oil level should be checked every 300 hours.

The level can be checked by removing the level plug (3). It should be topped up through the same hole until it begins to run out.

The oil should be drained (2) and changed every 500 hours. Use one of the following oils.

MIL-L-2105 90W EP MIL-L-2105B, C & D 80W EP

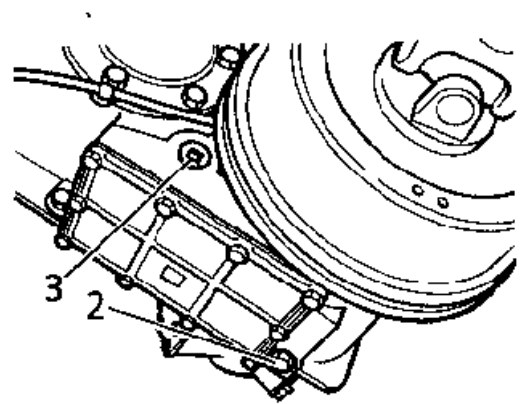

Battery

The battery fitted is 'maintenance free' and topping up is not normally required throughout the normal life of the battery. However, the level should still be checked when periodic services are carried out. Ensure terminals are kept clean and protected with petroleum jelly.

An isolator switch is fitted to the nearside engine cover for use in emergencies or when any welding or repairs are being carried out to the machine.



Wiring system

A main feed is taken from the battery to a power distribution "bobbin" on the main electrical panel inside the main fuse box. The same panel is fitted with all the main fuses and relays.

The RDS, 4WS, wipers and fuel pump are all powered through the ignition switch. However some of the lights and auxiliary controls are powered directly from the battery – you should therefore make sure everything is switched off when leaving the machine.



Battery Isolator Switch

NB. It is most important that all wiring connections in the engine compartment and under the bonnet are protected from the corrosive effects of fertilisers and chemicals. All connections should be frequently checked, cleaned and coated with oil, dielectric grease, or other suitable anti-corrosive lubricant.

Spare Switches

There are two spare switches on the steering column switch bank which can be used for other things such as broadcasters etc. However please note the **maximum** current available for each switch is **12 amps**. The wires from these switches terminate behind the fuse board under the cab and they are fused in the column fuse board. (see below).

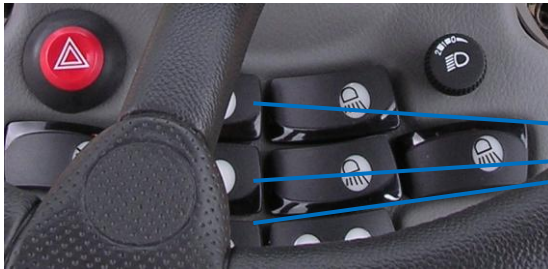

Spare Switches

Steering Column Fuses

	Steering Column	Amp
	Fuse Type – Std Blade	
1	Hazard / Indicators	15
2	Side lights (FB relay)	5
3	Panel lights	5
4	Dipped beam	15
5	Main beam	15
6	Ignition (power relays)	5
7	Instruments	5
8	Headlamp flash	15
9	Front worklamps (FB relay)	5
10	Spare switch 1	10
11	Step (FB relay)	5
12	Rear worklamps (FB relay)	5
13	Reverse lamps (FB relay)	5
14	Spare switch 2	10
15	Spare switch 3	10
15	Beacon (FB relay)	5

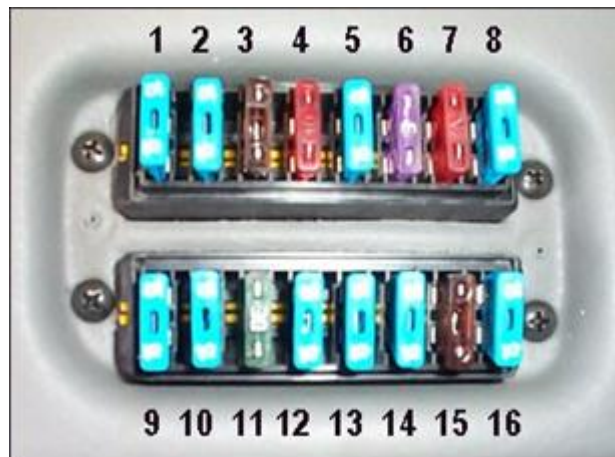

Fuses & Relays (For Machine build KELLAG 179 030212 February 2012)

The main fuse panel (Busman) can be accessed by removing the cover from the bottom of the tray behind the handbrake and gear levers. There are two secondary fuse boxes on the right hand side of the steering column.

Should any fuses require replacement please ensure they are replaced with the correct size or serious damage to the wiring system and particularly the electronic components can occur.

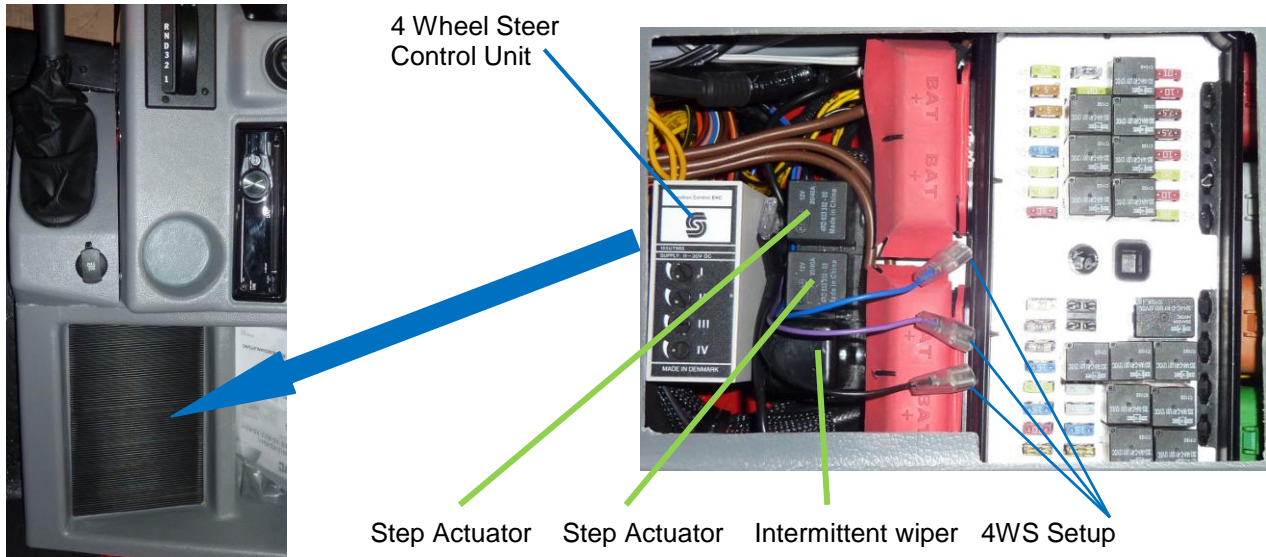

Busman Relays

- 1 Electro-hydraulics, spare ign feeds
- 2 N/U (MUST BE REMOVED)
- 3 Spare switch 2
- 4 Side Lights
- 5 Reversing Lights
- 6 Beacon
- 7 Front work lamps – Mid
- 8 Rear work lamps – Top
- 9 Front work lamps – Top
- 10 Rear work lamps – Sprayer
- 11 Engine ECU 1
- 12 Electronic seat / Spare relay
- 13 Engine ECU
- 14 Transmission ECU
- 15 Air con condenser fan
- 16 Spare switch 2

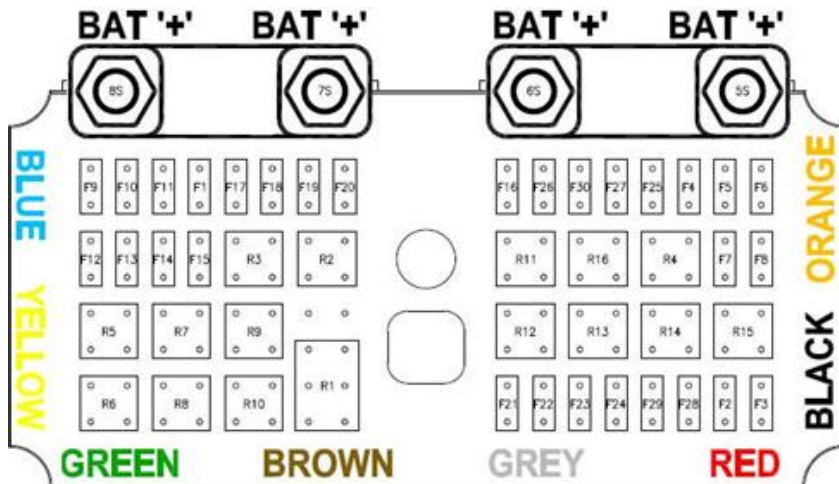

Relay & Fuse Board

(mounted beneath clothing locker)

Fuse

F32 Battery Live
 F33 Busman feed
 F34 Busman feed

Relay

A Power to Busman
 B Power to Busman
 C Glow Plug
 D Start
 E Fuel Pump

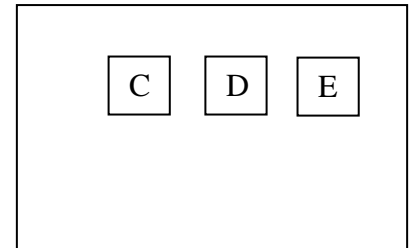
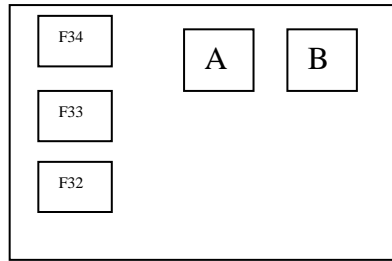

Main (Busman) Fuses

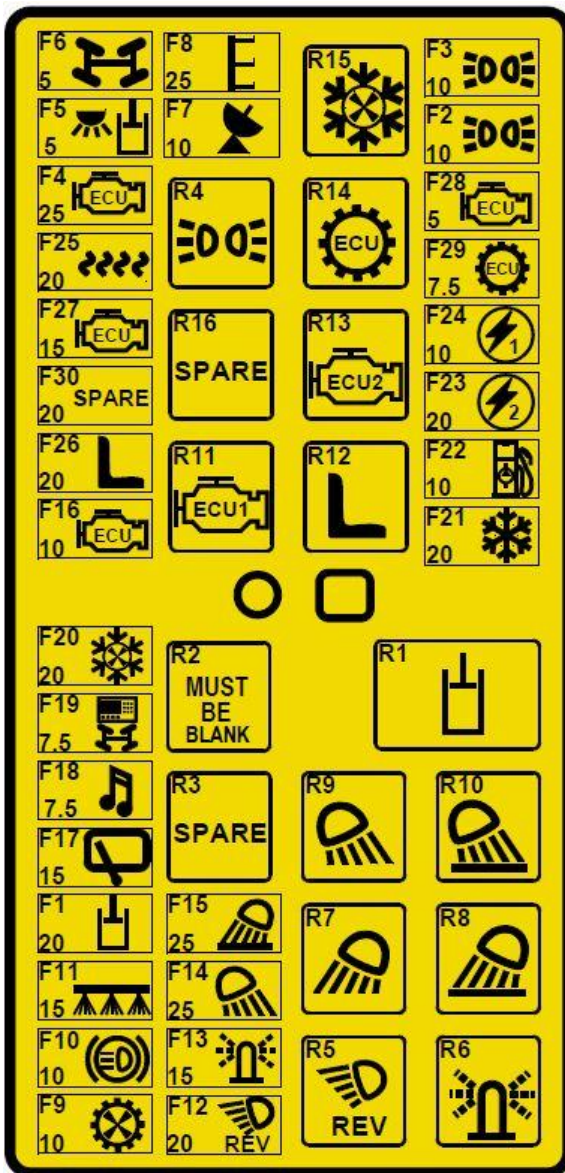

Main Fuses		
Fuse Type – Mini Blade		
1	Electro-hyd, spare sw2, ign	20
2	Side lights LH	10
3	Side lights RH	10
4	ECU Bat supply	5
5	Door sw/Interior lamp	5
6	4WS batt supply	5
7	Boutmarker / GPS	20 /10
8	Step supply	25
9	Transmission cooler	20
10	Stop lights	10
11	Sprayer controls	15
12	Reverse lights	20
13	Beacon	15
14	Front work lamps	25
15	Rear work lamps	25
16	Engine ECU 1	15
17	Wiper	15
18	Radio	7.5
19	RDS/4WS	7.5
20	Air condenser fan	20
21	Air con	20
22	Fuel pump/Rem PTO Sw	10
23	Power jack 2	20
24	Power jack 1	10
25	Heater	20
26	Electric seat/Spare (Ign)	20
27	ECU Ign	5
28	Engine ECU 2	7.5
29	Transmission	10
30	Spare Sw 1	20

Maintenance - Brakes

Handbrake

Adjustment

1. Chock the wheels and ensure the brake lever is off.
2. Raise one of the rear wheels clear of the ground and support the axle with an axle stand.
3. Tighten the adjusting bolt (3 right) until brake drum will not rotate by hand.
4. Slacken the adjuster by turning it 1.5 turns anti-clockwise and ensure the drum rotates freely.

If the actuating cable becomes slack, the free play can be taken up by adjusting the cable fitting in the cab (see right).

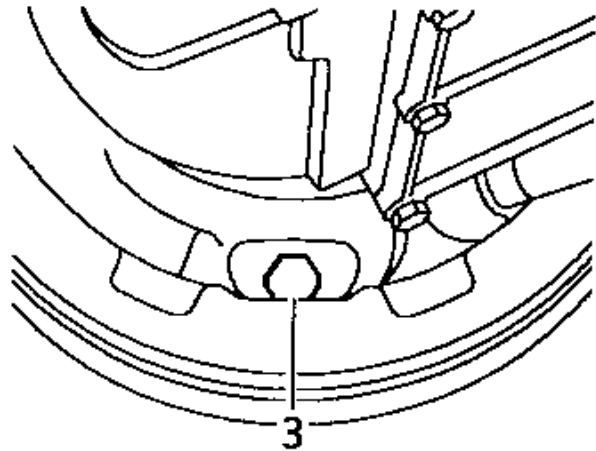

Lubrication

A grease nipple is also fitted into the operating cable approx 300mm up from the brake calliper. This should be greased every 50 hours.



Shoe replacement

If the adjuster reaches the end of its travel, the brake shoes will need replacing. To do so the rear prop shaft will need to be removed and the drum will then slide off after slackening off the adjuster.

The drum should be removed every 600 hours to clean the brake. If you are working in very wet and muddy conditions or if you are spreading a lot of fertiliser then it may require cleaning every 300 hours.

Foot brakes

The brake fluid reservoir is situated behind the cab next to the engine coolant header tank. Top up with 'Universal' brake fluid to between the 'max' and 'min' marks on the reservoir.

The linkage from the brake pedal to the master cylinder should be lubricated regularly.

The brakes are all self adjusting discs and only need to be checked for wear periodically. Have the pads replaced before they get right down to "bare metal". When working in muddy conditions check pads weekly.



Brake fluid reservoir

If you use your Agribuggy to spread a lot of fertiliser, inspect the metal brake pipes regularly for signs of corrosion and replace if necessary.

Brake servo

The Agribuggy braking system has hydraulic servo assistance powered by oil taken from the main hydraulic system on the machine.

This should not be confused with the brake fluid reservoir which operates the actual brake calipers (see previous page)

Steering

The steering on the Agribuggy is hydrostatic with the oil supply for the steering unit being taken from the main hydraulic system on the machine.

Lubrication

There are grease nipples on the steering king pins which require greasing every 100 hours (see illustration).

Please note on four wheel steer machines the front and rear steering systems are not connected in any way - either mechanically or hydraulically. See appendix 1 for further information on the four wheel steering system.

Steering stop Adjustment

When fitting row crop wheels for late season work you may find it necessary to adjust the steering stops to stop the wheels fouling the cab. This will almost certainly be the case if you are working on track widths of less than 68".

To adjust the stops, firstly turn the steering until the wheels are just clearing the cab on LH lock and then simply slacken off the lock-nut and screw out the stop until it touches the swivel housing. Repeat for RH lock.

When screwing the stops in, it is important that they are not screwed in further than the original factory settings. This will cause the swivels to over-rotate causing damage to the seals and may also result in damage to the axle drive shafts.

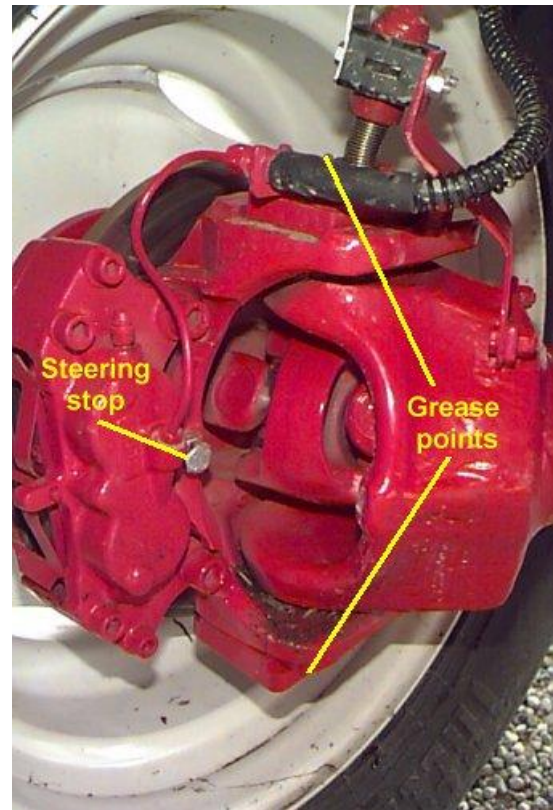

Maintenance –Axles

Axle drive shafts

The axle drive shafts are fitted with sealed universal joints and therefore require no maintenance. However **it is essential that swivel housing area is kept clean**. When working in adverse conditions any mud or crop debris that accumulates around the drive shaft must be washed out daily. If it is left to accumulate it will wear the hub and axle oil seals which will eventually cause oil leaks and premature wear to the wheel and drive shaft bearings.

Wheel hubs

The wheel hub/epicyclic units on the Agribuggy axles are filled with oil. The level should be checked every 300hrs. The hub should be rotated until the oil level/filler plug is in the position as shown on the right.

Use EP85/140 oil for topping up.

The oil should be changed every 500 hrs. To drain the oil rotate the hub until the level/filler hole is at its lowest position.

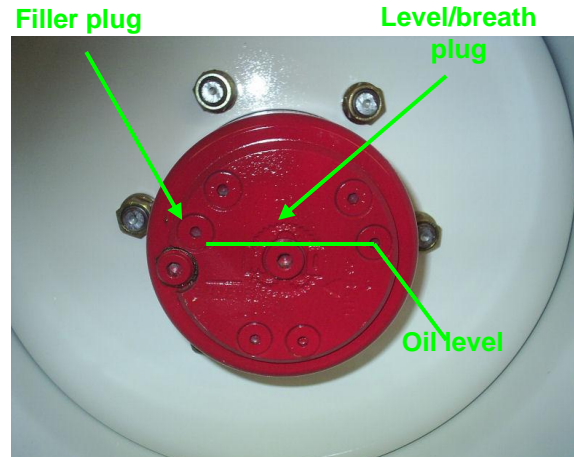

Wheel Bearings

The wheel bearings should be checked regularly for signs of play. Should any play become evident they can be adjusted by either Kellands, your dealer or by a suitably trained engineer.

Axle Oil levels

Use EP 85/140 gear oil for topping up the axle oil levels. The filler/level plugs are shown on the diagrams on the right

The axle oil should be changed every 500hrs.



Rear axle (4ws version shown)

Axle breathers

Should any axle oil leaks develop, the axle breather should be removed first and checked to make sure it is not blocked. Some breathers have a small ball fitted inside which is prone to seizure, particularly when spreading fertiliser.

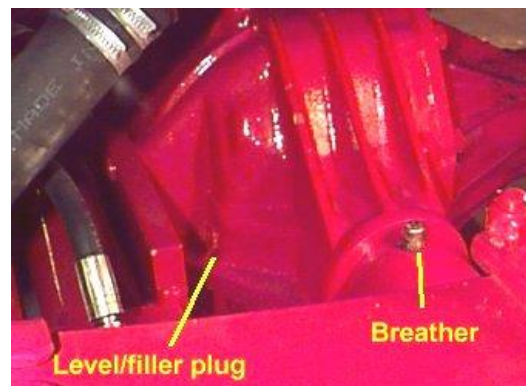

Front axle

Wheel alignment

The front axle should have a toe-in of 1-2mm and the rear steer axle (4ws machines only) should toe-out 1-2mm.

Greasing.

Grease nipples are located as follows and all nipples should be greased every 50 hrs.

Prop shafts - 2 on each universal joint and 1 on the centre sliding section

Handbrake cable - 1

Axle king pins - 4 on front axle (4 also on four wheel steer rear axle)

Tyres

The low pressure tyres are normally preset at 11 psi (0.7 bar). The pressure may be reduced in adverse conditions to as low as 8 psi (0.6 bar) depending on the load being carried. However the main thing to watch is that the tyre side walls do not crease when loaded. If the machine is being used for long periods on the road the pressure should be increased to 14 psi (1 bar). Row crop tyres should be inflated to 35 psi (2.4 bar).

Cleaning

Mud and crop debris should be cleaned away from the steering swivel and brake calipers on a daily basis to avoid damage to axle oil seals and bearings.

Do not allow crop debris to build up on the engine, exhaust or in any of the cooling system radiators - this should be checked on a daily basis when working in tall or dusty crops.

Great care should be taken in cleaning the machine, particularly after spreading fertiliser. Some types of fertiliser are very corrosive and if not cleaned daily, problems will soon be encountered.

The wiring system is most vulnerable and connections should be checked regularly. The radiator is also susceptible to corrosion and every effort should be made to keep fertiliser out of the radiator core.

After washing off, leave engine running for a while so that the engine compartment dries out.

Some types of fertiliser spreaders are prone to throwing fertiliser forwards or making a lot of dust. If this is the case with your spreader it is advisable to fit a sheet or screen in front of the spreader to stop it getting into the engine compartment.

Coating the chassis with a mixture of oil and diesel, or a proprietary anti-corrosive coating agent, after cleaning, pays dividends if you spread large amounts of fertiliser.

It also pays to go round the machine with the grease gun and an oil can on a daily basis when the machine is being used intensively for spreading fertiliser in damp conditions.

Please remember the warranty does not cover problems caused by corrosion and mud/debris build up!

Maintenance Schedule

Service Operation	Daily 10 Hours	First 50 Hours	Every 50 Hours	250 Hours 6 mths	500 Hours 1 yr	1000 Hours 2 yrs
1 Check engine oil level and top up if necessary	*	*	*	*	*	*
2 Check coolant level and top up if necessary	*	*	*	*	*	*
3 Check cooling radiators/steering swivels for cleanliness	*	*	*	*	*	*
4 Check wheel nuts for tightness	*	*	*	*	*	*
5 Grease prop shafts & check for wear	-	*	*	*	*	*
6 Grease kingpins & check for wear	-	*	*	*	*	*
7 Grease hydraulic pump drive	-	*	*	*	*	*
8 Lubricate electrical connections	-	*	*	*	*	*
9 Check brake fluid level	-	*	*	*	*	*
10 Check power steering fluid level	-	*	*	*	*	*
11 Check automatic transmission fluid level	-	*	*	*	*	*
12 Check hydraulic filter indicator	-	*	*	*	*	*
13 Check fuel water trap and clean if necessary	-	*	*	*	*	*
14 Drain water from fuel filter	-	*	*	*	*	*
15 Check/clean radiator screen	-	*	*	*	*	*
16 Check condition of drive belts & pulleys	-	*	-	*	*	*
17 Change engine oil and filter (Use semi-synthetic oil as specified)	-	*	-	*	*	*
18 Check for oil, fuel & coolant leaks	-	*	-	*	*	*
19 Check battery water level	-	*	-	*	*	*
20 Tighten leaf spring U bolts	-	*	-	*	*	*
21 Check engine, prop-shafts, steering joints are tight	-	*	-	*	*	*
22 Grease handbrake cable & oil brake pedal linkage	-	-	-	*	*	*
23 Clean & adjust transmission brake	-	-	-	*	*	*
24 Clean & lubricate battery terminals	-	-	-	*	*	*
25 Clean engine breather filter	-	-	-	*	*	*
26 Check transfer gearbox oil level	-	-	-	*	*	*
27 Check condition & security of wiring looms	-	-	-	*	*	*
28 Renew fuel filter elements primary & secondary	-	-	-	*	*	*
29 Visually check for exhaust smoke & system leaks	-	-	-	*	*	*
30 Check all air, oil and water hoses for leakage, damage or deterioration	-	-	-	*	*	*
31 Remove wheels, check brakes for wear and replace pads if necessary	-	-	-	*	*	*
32 Check axle/wheel hub oil levels	-	-	-	*	*	*
33 Drain fuel tank	-	-	-	*	*	*
34 Replace cab carbon filter	-	-	-	*	*	*
35 Check wheel alignment on steering axles	-	-	-	*	*	*
36 Check & adjust wheel bearings if necessary	-	-	-	-	*	*
37 Change air filter elements	-	-	-	-	*	*
38 Replace hydraulic oil and filter, clean suction element	-	-	-	-	*	*
39 Change all axle and transfer gearbox oils	-	-	-	-	*	*
40 Change auto transmission oil	-	-	-	-	*	*
41 Change auto transmission oil and filter	-	-	-	-	-	*
42 Replace main drive belts	-	-	-	-	-	*
43 Flush out cooling system & renew coolant	-	-	-	-	-	*
44 Drain brake fluid, replace & re-bleed	-	-	-	-	-	*

Parts

Parts.

All replacement parts are available from Kellands Agricultural. Some parts may also be available from other local sources. Only genuine replacement parts should be used during the warranty period and we strongly recommend that you do the same after the warranty has expired. If you require any parts information please do not hesitate to contact us.

When ordering parts please quote the Agribuggy model/build no. which can be found on a plate on the front right hand corner of the chassis.

If you are in any doubt about operating or maintaining the machine or fitting any of your own equipment please do not hesitate to contact us.

This instruction book covers all the most important points on operation and servicing of the Agribuggy but, by no means, does it cover everything in full detail. It is updated periodically and we would therefore welcome any suggestions of further information that you would like to see included. We hope to produce a more detailed workshop manual and parts book in the not too distant future.

The manufacturer cannot be held responsible for any accident, injury, or any other occurrence resulting from the incorrect use of the machine or equipment fitted to it.

FOUR WHEEL STEERING SYSTEM

The four wheel steer system on the Agribuggy is controlled electronically. Signals from sensors mounted on both axles are continually monitored by the electronic control box and a varying signal is sent from the control to an electro-hydraulic proportional valve which, in turn, directs oil to the steering ram on the rear axle to ensure the rear wheels are always kept in the correct position. The rear wheel position is also continually monitored when in two wheel steer and crab modes, again, to ensure that the wheels do not "creep" and to keep them in the correct position.

Safety precautions

1. Always ensure the rear wheel area is clear before activating the four wheel steer system.
2. Always switch to the roadwork position for speeds above 12 m.p.h. (20 kph)
3. Do not switch modes when travelling at speed.
4. Danger of trapping, on no account allow any person to be placed between the wheels and chassis while the engine is running, always remove the ignition key and isolate the battery before accessing the area.



The control panel

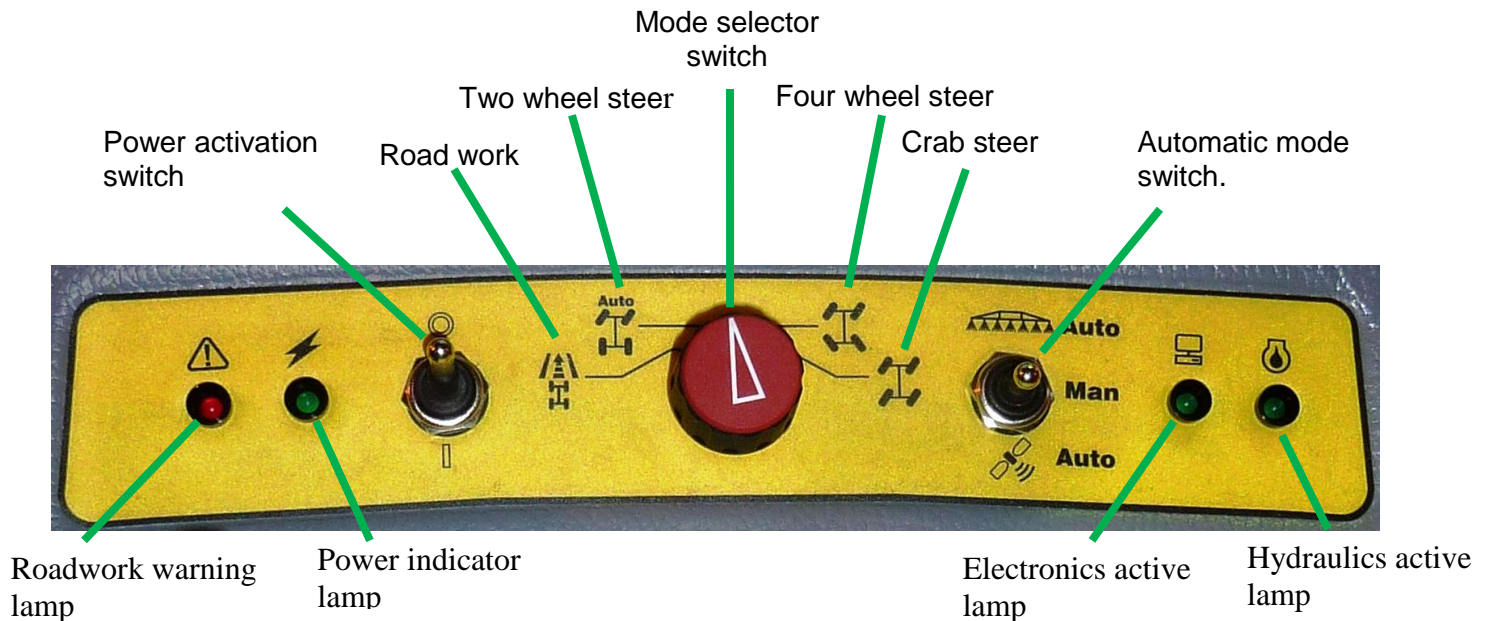

Operating

The FWS system should be activated immediately after starting the engine. Ensure the rear wheel area is clear and then press the "Power activation" switch down on the control panel. The green power indicator lamp should then light up to show there is power to the system.

The "Electronics Active" and "Hydraulics Active" lamps will also light up as long as the mode selector switch is not in the "Roadwork" position.

All three green lamps must be lit up for the electronic control system to function correctly.

Four Wheel Steering

Operating modes



Two wheel steer. In Two Wheel Steer mode the rear axle position is monitored continually and fine adjustments will be made by the system to ensure the wheels keep straight. All three green lamps must be lit up for this to work correctly. You may switch to this position at any time in the field and the rear wheels will straighten up automatically.

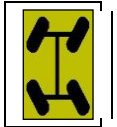

Four wheel steer. In Four Wheel Steer mode the rear wheels will always follow the front ones and will give you the tightest turning circle. However, you may find the machine easier to steer down the field if you switch back to Two Wheel Steer after turning. You may switch to and from this position at any time in the field and the rear wheels will re-align automatically.

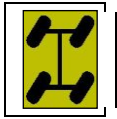

Crab steer. Crab steer may sometimes be useful when maneuvering in buildings and in tight corners in fields. The rear wheels turn in the same direction as the front ones allowing the machine to move sideways.

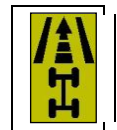

Road work. In the Roadwork position the electronics are deactivated for safety and the rear axle will lock. Before switching to this position, allow the rear wheels to straighten up in Two Wheel Steer. After a few miles on the road the wheels may tend to "creep". If this happens slow down to less than 5 mph, switch back to Two wheel Steer (which will quickly straighten the rear wheels) and then switch back to Roadwork again. An audible alarm and red warning lamp are fitted in the control box which will both activate at speeds above 12 m.p.h. when in any of the other steering modes.

Auto mode (if fitted). If the control box has the optional auto mode fitted the system can be made to switch from 2WS to 4WS automatically as the sprayer is switched on and off for ease of steering down the field and for optimum turning on the headlands.

The Auto mode switch has three positions, **central** position - manual or off, **up** - for auto when used with manual spray controls and **down** - when used with Boompilot GPS Autoboom shut off.

To activate auto mode, switch the control (on the steering control panel to RH of the rotary mode switch) to the appropriate position (up or down dependent upon spray control – auto or manual) and turn the main mode control knob to 2WS. The mode will then change automatically as the main sprayer control is switched on and off. If you wish to use 4WS whilst driving down the field, then simply turn the main mode control knob to the 4WS position to over-ride the auto function.

The auto mode function is activated by a single additional input into the 4WS control box. If you are fitting your own sprayer or spreader and wish to use this feature then the wire must be attached to your control circuit so that it is live (12V) when the implement is switched OFF. If you do not have a live connection when in the off position then a relay system must be used. For further information please contact Kellands Agricultural.

Safety systems

There are two safety systems built into the unit - one in the hydraulic control valve and one in the electronic control box. Should either of the systems detect a fault then one of the green lamps will go out on the control panel and the system will cease operating or "lock-out". To reset the system, turn the ignition off, restart the engine and re-activate the system.

The valve safety system will often lock out if the unit is switched on when the engine is not running. This is normal and will reset itself when the engine is started. The control box safety system will lock out if it receives wildly varying signals from each axle - this can happen, for example, if the front steering is operated after engine start-up and before activating the FWS system. If this happens, re-align the front wheels with the rear wheels and then reset the system as above. It will also lock out if sensor wires or sensors are damaged.

Emergency operation

Should the system fail completely it can be operated manually to "get you home" as follows: Leave the control box switched **OFF** after starting the engine and attach the manual lever supplied to the hydraulic control valve. The valve is situated under the engine cover behind the intercooler. Operate the lever to centralise the rear wheels. The Agribuggy can then be driven and operated as normal.

You will find, however, that the rear steering will tend to creep out of position after a while and will need further periodic manual realignment until the fault can be rectified.



Steering control
valve lever

Row crop wheel settings

