

Publication 1080
May 2024
Part No. 24215.80



McCONEl

POWERLODA

Mini-Loader Models: 325 & 325T
21HP Petrol Engine

Operator Manual



IMPORTANT

VERIFICATION OF WARRANTY REGISTRATION



Dealer Warranty Information & Registration Verification

It is imperative that the selling dealer registers this machine with McConnel Limited before delivery to the end user – failure to do so may affect the validity of the machine warranty.

To register machines; log onto <https://my.mcconnel.com> and select 'Machine Registration' which can be found in the 'Warranty' section of the site. **Confirm to the customer that the machine has been registered by completing the verification form below.**

Registration Verification	Serial No. <input type="text"/>
Dealer Name:	
Dealer Address:	
Customer Name:	
Date of Warranty Registration:/...../..... Dealer Signature:	

Note to Customer / Owner

Please ensure the section above has been completed and signed by the dealer to verify your machine has been registered with McConnel Limited.

IMPORTANT: During the initial 'bedding in' period of a new machine it is the customer's responsibility to regularly inspect all nuts, bolts and hose connections for tightness and re-tighten if required. New hydraulic connections occasionally weep small amounts of oil as the seals and joints settle in – where this occurs it can be cured by re-tightening the connection – *refer to torque settings chart below*. The tasks stated above should be performed on an hourly basis during the first day of work and at least daily thereafter as part of the machine's general maintenance procedure.

CAUTION: DO NOT OVER TORQUE HYDRAULIC FITTINGS AND HOSES

Torque Settings for Hydraulic Fittings

Hydraulic Hose Ends		
BSP	Setting	Metric
1/4"	18 Nm	19 mm
3/8"	31 Nm	22 mm
1/2"	49 Nm	27 mm
5/8"	60 Nm	30 mm
3/4"	80 Nm	32 mm
1"	125 Nm	41 mm
1.1/4"	190 Nm	50 mm
1.1/2"	250 Nm	55 mm
2"	420 Nm	70 mm

Port Adaptors with Bonded Seals		
BSP	Setting	Metric
1/4"	34 Nm	19 mm
3/8"	47 Nm	22 mm
1/2"	102 Nm	27 mm
5/8"	122 Nm	30 mm
3/4"	149 Nm	32 mm
1"	203 Nm	41 mm
1.1/4"	305 Nm	50 mm
1.1/2"	305 Nm	55 mm
2"	400 Nm	70 mm

WARRANTY POLICY

WARRANTY REGISTRATION

All machines must be registered, by the selling dealer with McConnel Ltd, before delivery to the end user. On receipt of the goods it is the buyer's responsibility to check that the Verification of Warranty Registration in the Operator's Manual has been completed by the selling dealer.

1. LIMITED WARRANTIES

- 1.01. *All mounted machines supplied by McConnel Ltd are warranted to be free from defects in material and workmanship from the date of sale to the original purchaser for a period of 12 months, unless a different period is specified.
All Self Propelled Machines supplied by McConnel Ltd are warranted to be free from defects in material and workmanship from the date of sale to the original purchaser for a period of 12 months or 1500 hours. Engine warranty will be specific to the Manufacturer of that unit.*
- 1.02. *All spare parts supplied by McConnel Ltd and purchased by the end user are warranted to be free from defects in material and workmanship from the date of sale to the original purchaser for a period of 6 months. All parts warranty claims must be supported by a copy of the failed part invoice to the end user. We cannot consider claims for which sales invoices are not available.*
- 1.03. *The warranty offered by McConnel Ltd is limited to the making good by repair or replacement for the purchaser any part or parts found, upon examination at its factory, to be defective under normal use and service due to defects in material or workmanship. Returned parts must be complete and unexamined. Pack the component(s) carefully so that any transit damage is avoided. All ports on hydraulic items should be drained of oil and securely plugged to prevent seepage and foreign body ingress. Certain other components, electrical items for example, may require particular care when packing to avoid damage in transit.*
- 1.04. *This warranty does not extend to any product from which McConnel Ltd's serial number plate has been removed or altered.*
- 1.05. *The warranty policy is valid for machines registered in line with the terms and conditions detailed and on the basis that the machines do not extend a period of 24 months or greater since their original purchase date, that is the original invoice date from McConnel Limited.
Machines that are held in stock for more than 24 months cannot be registered for warranty.*
- 1.06. *This warranty does not apply to any part of the goods, which has been subjected to improper or abnormal use, negligence, alteration, modification, fitment of non-genuine parts, accident damage, or damage resulting from contact with overhead power lines, damage caused by foreign objects (e.g. stones, iron, material other than vegetation), failure due to lack of maintenance, use of incorrect oil or lubricants, contamination of the oil, or which has served its normal life. This warranty does not apply to any expendable items such as blades, belts, clutch linings, filter elements, flails, flap kits, skids, soil engaging parts, shields, guards, wear pads, pneumatic tyres or tracks.*
- 1.07. *Temporary repairs and consequential loss - i.e. oil, downtime and associated parts are specifically excluded from the warranty.*
- 1.08. *Warranty on hoses is limited to 12 months and does not include hoses which have suffered external damage. Only complete hoses may be returned under warranty, any which have been cut or repaired will be rejected.*
- 1.09. *Machines must be repaired immediately a problem arises. Continued use of the machine after a problem has occurred can result in further component failures, for which McConnel Ltd cannot be held liable, and may have safety implications.*
- 1.10. *If in exceptional circumstances a non McConnel Ltd part is used to effect a repair, warranty reimbursement will be at no more than McConnel Ltd's standard dealer cost for the genuine part.*

- 1.11. *Except as provided herein, no employee, agent, dealer or other person is authorised to give any warranties of any nature on behalf of McConnell Ltd.*
- 1.12. *For machine warranty periods in excess of 12 months the following additional exclusions shall apply:*
 - 1.12.1. *Hoses, exposed pipes and hydraulic tank breathers.*
 - 1.12.2. *Filters.*
 - 1.12.3. *Rubber mountings.*
 - 1.12.4. *External electric wiring.*
 - 1.12.5. *Bearings and seals*
 - 1.12.6. *External Cables, Linkages*
 - 1.12.7. *Loose/Corroded Connections, Light Units, LED's*
 - 1.12.8. *Comfort items such as Operator Seat, Ventilation, Audio Equipment*
- 1.13. *All service work, particularly filter changes, must be carried out in accordance with the manufacturer's service schedule. Failure to comply will invalidate the warranty. In the event of a claim, proof of the service work being carried out may be required.*
- 1.14. *Repeat or additional repairs resulting from incorrect diagnosis or poor quality previous repair work are excluded from warranty.*

NB Warranty cover will be invalid if any non-genuine parts have been fitted or used. Use of non-genuine parts may seriously affect the machine's performance and safety. McConnell Ltd cannot be held responsible for any failures or safety implications that arise due to the use of non-genuine parts.

2. REMEDIES AND PROCEDURES

- 2.01. *The warranty is not effective unless the Selling Dealer registers the machine, via the McConnell web site and confirms the registration to the purchaser by completing the confirmation form in the operator's manual.*
- 2.02. *Any fault must be reported to an authorised McConnell Ltd dealer as soon as it occurs. Continued use of a machine, after a fault has occurred, can result in further component failure for which McConnell Ltd cannot be held liable.*
- 2.03. *Repairs should be undertaken within two days of the failure. Claims submitted for repairs undertaken more than 2 weeks after a failure has occurred, or 2 days after the parts were supplied will be rejected, unless the delay has been authorised by McConnell Ltd. Please note that failure by the customer to release the machine for repair will not be accepted as a reason for delay in repair or submitting warranty claims.*
- 2.04. *All claims must be submitted, by an authorised McConnell Ltd Service Dealer, within 30 days of the date of repair.*
- 2.05. *Following examination of the claim and parts, McConnell Ltd will pay, at their discretion, for any valid claim the invoiced cost of any parts supplied by McConnell Ltd and appropriate labour and mileage allowances if applicable.*
- 2.06. *The submission of a claim is not a guarantee of payment.*
- 2.07. *Any decision reached by McConnell Ltd. is final.*

3. LIMITATION OF LIABILITY

- 3.01. *McConnell Ltd disclaims any express (except as set forth herein) and implied warranties with respect to the goods including, but not limited to, merchantability and fitness for a particular purpose.*
- 3.02. *McConnell Ltd makes no warranty as to the design, capability, capacity or suitability for use of the goods.*
- 3.03. *Except as provided herein, McConnell Ltd shall have no liability or responsibility to the purchaser or any other person or entity with respect to any liability, loss, or damage caused or alleged to be caused directly or indirectly by the goods including, but not limited to, any indirect, special, consequential, or incidental damages resulting from the use or operation of the goods or any breach of this warranty. Notwithstanding the above limitations and warranties, the manufacturer's liability hereunder for damages incurred by the purchaser or others shall not exceed the price of the goods.*
- 3.04. *No action arising out of any claimed breach of this warranty or transactions under this warranty may be brought more than one (1) year after the cause of the action has occurred.*

4. MISCELLANEOUS

- 4.01. McConnel Ltd may waive compliance with any of the terms of this limited warranty, but no waiver of any terms shall be deemed to be a waiver of any other term.*
- 4.02. If any provision of this limited warranty shall violate any applicable law and is held to be unenforceable, then the invalidity of such provision shall not invalidate any other provisions herein.*
- 4.03. Applicable law may provide rights and benefits to the purchaser in addition to those provided herein.*

McConnel Limited



For Safety and Performance...

ALWAYS READ THE BOOK FIRST



McCONEL LIMITED

**Temeside Works
Ludlow
Shropshire
England**

**Telephone: +44 (0)1584 873131
www.mcconnel.com**



In line with our policy of constant improvement this publication may be periodically updated. To ensure you have access to the latest version of this manual please visit the manuals library on our website where an up-to-date version can be referenced online or downloaded.

To access manuals use the QR code opposite or the web address below;
<https://www.mcconnel.com/support/parts-and-operators-manual/>

CONTENTS

General Information.....	1
Introduction.....	2
Component Identification.....	3
Safety Section	5
Decals	8
Decal Maintenance	9
Specifications & Dimensions	9
Operation.....	12
Machine Pre-Start Up Checks.....	12
Checking the Engine.....	12
Tyres and Traction	13
Track Maintenance Tips.....	13
Operating Instructions	14
Safety Recommendation for Operator	14
Work Area Checks	14
Machine Controls.....	15
Pump Selector	15
Throttle Control	15
Crowd/Tilt Lever	15
Drive Control Levers	15
Arm Lever Up/Down.....	16
Flow Divider Control.....	16
Ignition Switch.....	16
Engine Warning Light.....	16
4-in-1 Bucket Control	16
Auxiliary Control.....	16
Fuel Gauge	16
Power Socket.....	16
Stopping the Machine	17
Moving a Non-Functioning Machine.....	17
Attachments	18
Connecting Attachments	18
Disconnecting Attachments.....	18
Transport & Securing.....	19
Maintenance	20
Air Filter.....	20
Bushes & Pins.....	20
Engine Oil	20
Hydraulic System	20
Battery	21
Maintenance Schedule	22
Troubleshooting.....	24

GENERAL INFORMATION

Read this manual before fitting or operating the machine or accessory. Whenever any doubt exists contact your local dealer or the McConnel Service Department for assistance.

Only use 'Genuine McConnel Parts' on McConnel machinery and equipment.

DEFINITIONS: *The following definitions apply throughout this manual;*

⚠ DANGER

DANGER: Alerts to a hazardous situation which will result in death or serious injury if not observed carefully.

⚠ WARNING

WARNING: Alerts to a hazardous situation which could result in death or serious injury if not observed carefully.

⚠ CAUTION

CAUTION: Alerts to a hazardous situation which could result in damage to the machine and/or equipment if not observed carefully.

NOTICE

NOTICE: Specific or general information considered important or useful to emphasise.

LEFT HAND (LH) & RIGHT HAND (RH): *These terms are applicable to the machine when fitted to the tractor and viewed from the rear; these terms also apply to tractor references.*

SERIAL PLATE

All machines are equipped with a serial number plate containing important information relating to the machine including a unique serial number used for identification purposes.

Note: Images in this manual are provided for instruction and informational purposes only and may not show components in their entirety. In certain instances images may appear different to the actual machine; where this occurs the general procedure will be basically the same. E&OE.

MACHINE & DEALER INFORMATION

Record the serial number of your machine on this page and always quote it when ordering parts. Whenever information concerning the machine is requested remember to also state the make and model of tractor to which the machine is fitted.	
Machine Serial Number:	Installation Date:
Engine Serial Number:	
Machine Model Details:	
Dealer Name & Branch:	
Dealer Address:	
Dealer Telephone No:	
Dealer Email Address:	

INTRODUCTION

The McConnel **POWERLODA 325** and **325T** are self-propelled, operator driven mini-loaders with a rated lift capacity of 325kg and available in all-wheel drive or tracked chassis variants. The machines are powered by Kohler EFI 21HP Petrol engines that deliver low emissions and excellent fuel economy.

The **POWERLODA 325** all-wheel drive model is perfect for all terrains and features optional narrow wheel and hub set to enable a quick change of the set-up to access narrow spaces whenever required.

The **POWERLODA 325T** is a versatile tracked loader with a low centre of gravity suited for sensitive or difficult ground conditions making it ideal for working on grass, sand or muddy conditions.

Machine can be equipped with a variety of attachment tools making them an ideal operating platform for contractors and professional users.

These machines must only be used to perform the task for which they were designed, use of the machine for any other reasons is dangerous to persons and risks damaging the machine.



POWERLODA 325 Model

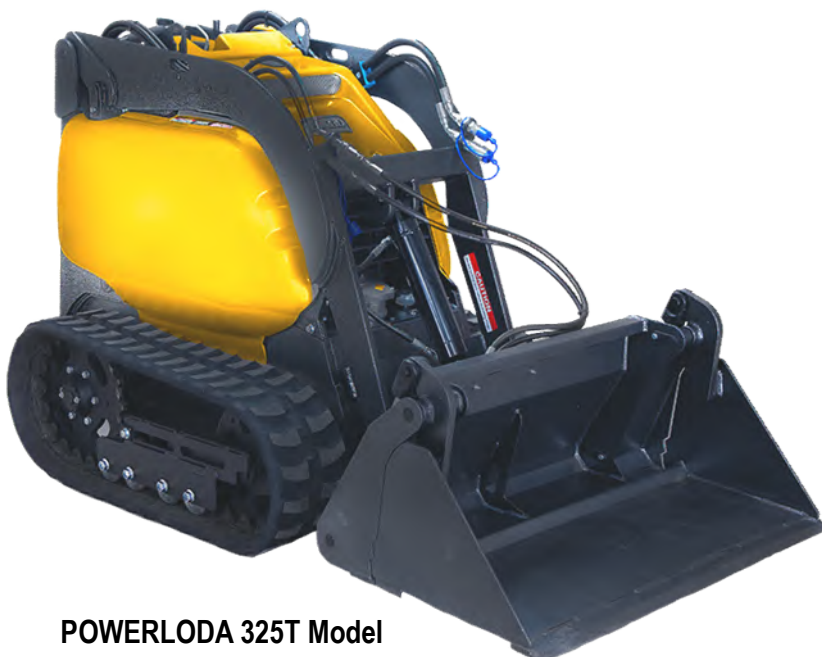

POWERLODA 325T Model

COMPONENT IDENTIFICATION

POWERLODA 325 Model

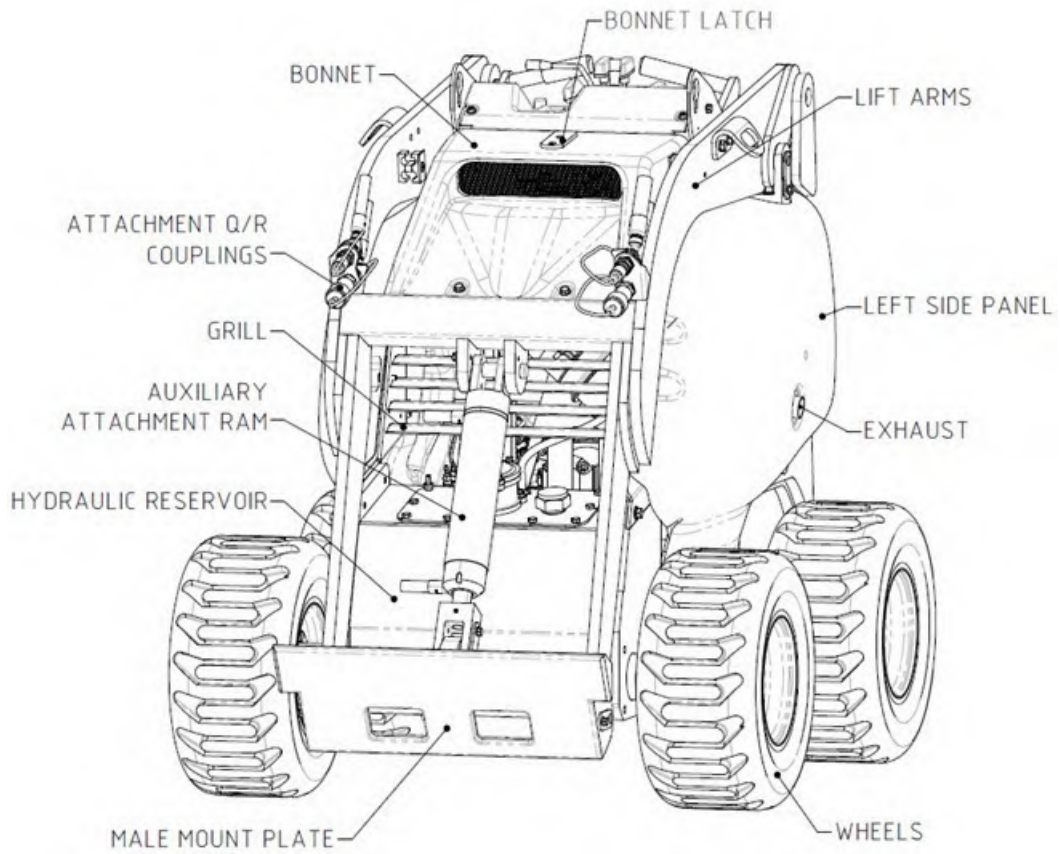

POWERLODA 325 – Front View

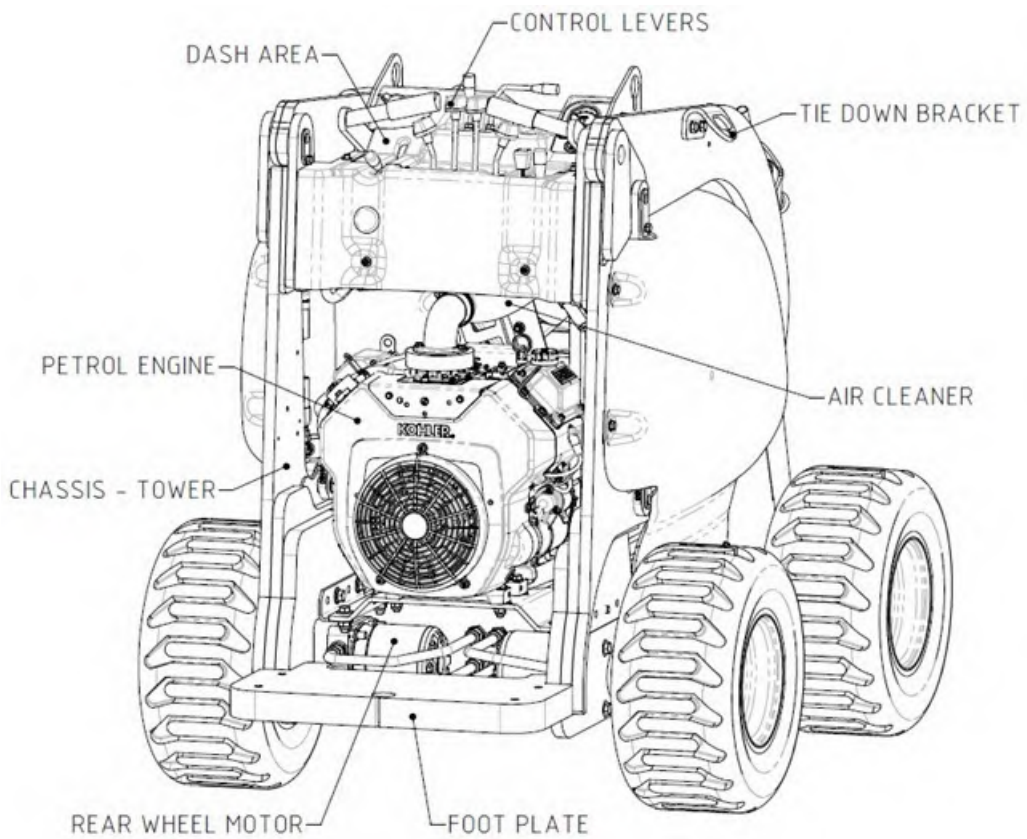

POWERLODA 325 – Rear View

POWERLODA 325T Model

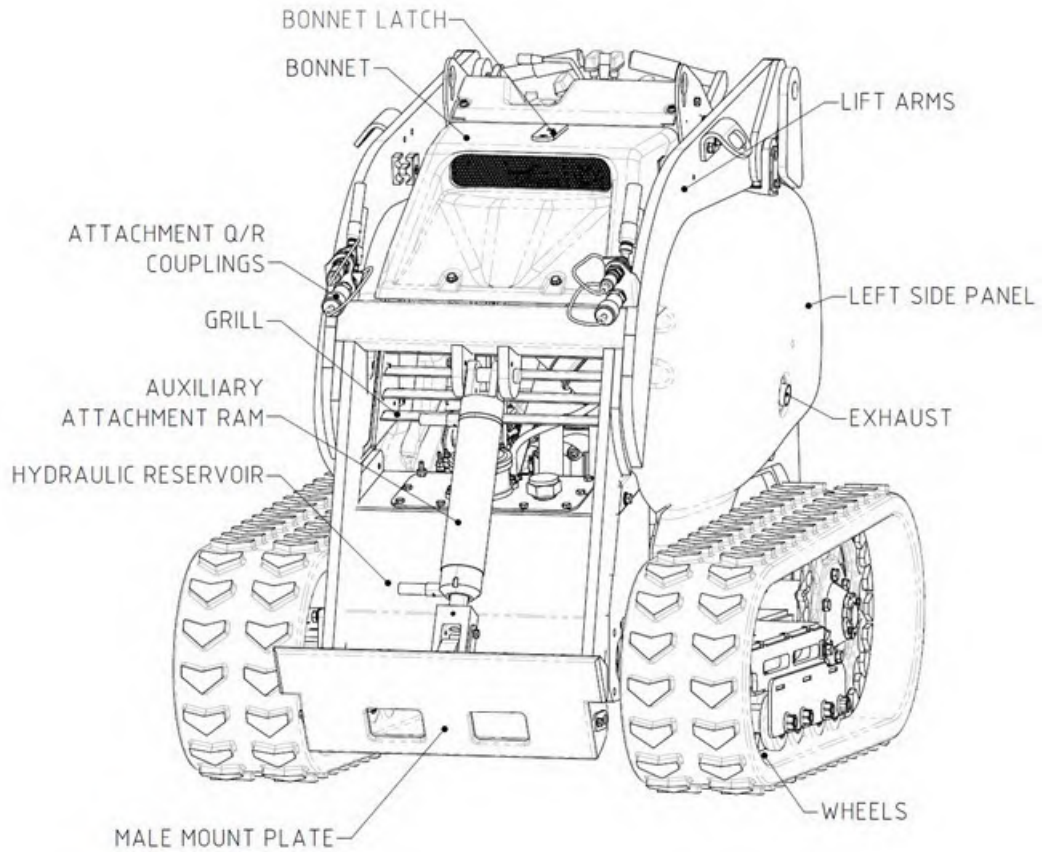

POWERLODA 325T – Front View

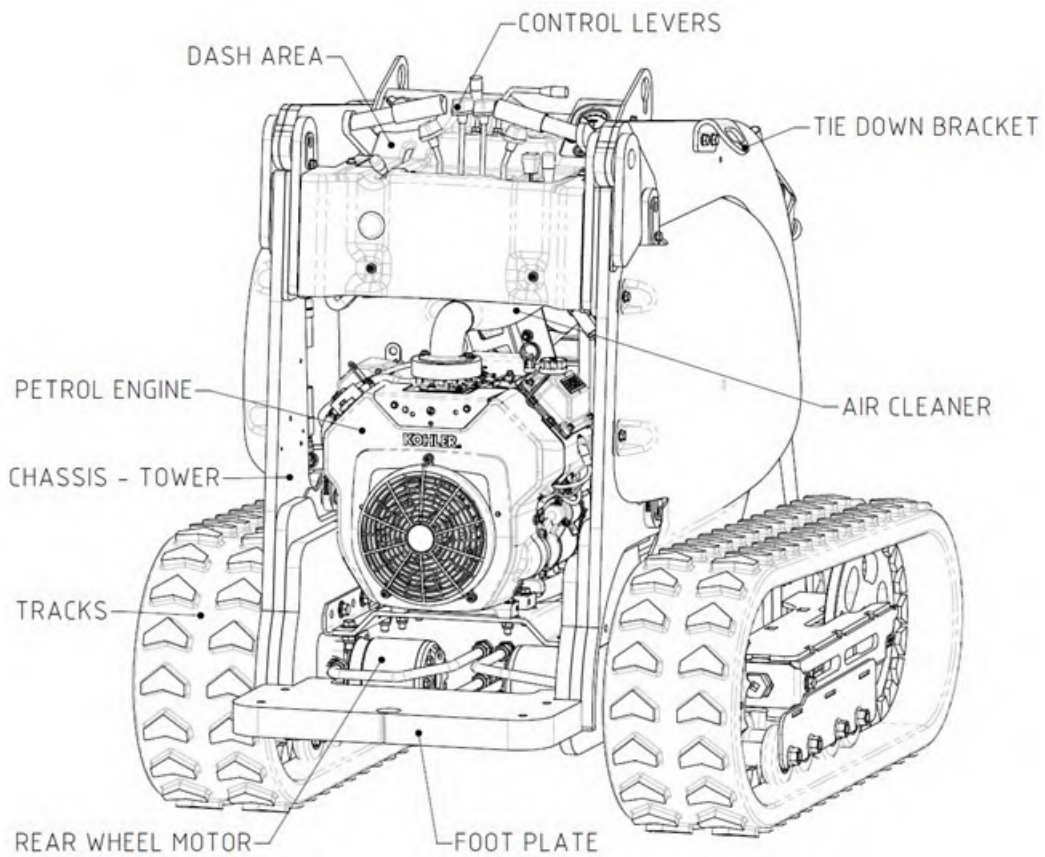

POWERLODA 325T – Rear View

SAFETY INFORMATION

































Read the manual before using the machine









This machine has the potential to be extremely dangerous - in the wrong hands it can kill or maim; It is therefore imperative that both owner and operator of the machine reads and understands the following section to ensure they are fully aware of the dangers that do, or may exist, and their responsibilities surrounding the use and operation of the machine.

The operator of this machine is responsible not only for their own safety but equally for the safety of others who may come into the close proximity of the machine, as the owner you are responsible for both.

When the machine is not in use attachments should be lowered to rest on the ground. In the event of any fault being detected with the machine's operation it must be stopped immediately and not used again until the fault has been corrected by a qualified technician.

-  **KEEP** hands, feet, and clothing away from all moving parts.
-  **WEAR** appropriate clothing, including a hard hat, safety glasses, long trousers, and safety shoes when operating the machine.
-  **ONLY ALLOW** responsible adults familiar with operation of this machinery to use the machine.
-  **OPERATORS** are responsible for operating away from pedestrians and establishing appropriate isolation measures.
-  **NEVER** carry passengers and keep pets and bystanders away from the machine.
-  **DO NOT** refuel while engine is running or while you or someone nearby is smoking.
-  **DO NOT** exceed the rated operating capacity.
-  **DO NOT** place your feet under the platform.
-  **DO NOT** operate any control levers (including auxiliary lever) unless you are standing with both feet firmly on the platform and firmly holding the grip handles.
-  **DO NOT** operate on or near embankments. Look out for ditches, holes, etc. Beware of traffic when near roads.
-  **WATCH** where you are driving, and always look down and behind before and while reversing.

-  **WARNING:** Engine exhaust contains **Carbon Monoxide**, an odourless, deadly poison. **Do not** run the engine indoors or in confined spaces.
-  **NEVER** allow the machine arms to free fall without the engine running to prevent a vacuum/ air lock in the lift cylinders.
-  **ALWAYS** lower machine arms and place attachment (if fitted) on the ground when parking or leaving the machine unattended.
-  **ALWAYS** stop the engine if leaving the operator platform.
-  **DO NOT** carry a load or heavy attachment with the machines arms in a raised position.
-  **DO NOT** step off the platform with a load raised.
-  **NEVER** jerk the control levers; instead, use a steady motion. Slow down before turning, as sharp turns may cause loss of control.
-  **STOP ENGINE** before making any adjustments to the attachments or the machine.
-  **BEWARE** when a bucket is being used to carry solid items such as rocks or other bulky materials, the bucket edge should always remain as close to horizontal as possible to minimize any roll-back hazard.
-  **ONLY** operate in daylight or good artificial lighting.
-  **DO NOT** operate equipment while under the influence of alcohol or drugs or while otherwise impaired.
-  **USE EXTRA CARE** while loading or unloading the machine onto a trailer.
-  **DO NOT** touch equipment or attachment parts that may be hot from operation. Allow components to cool before attempting to maintain, adjust or service the machine.
-  **NEVER** let children or untrained people operate or service the machine.
-  **DO NOT** allow any persons or animals to approach the machine or its attachments whilst in operation. **Stop** the machine if any person or animal approaches.
-  **BE AWARE** when operating on uneven ground; this requires extra caution. **Do not** operate on uneven ground exceeding 5 degrees. If a slope exceeds 5 degrees, only go up or down – **never across**.
-  **ALWAYS** have the heavy end of the machine uphill. Weight distribution will change; an empty bucket will make the rear of the machine heaviest, and a loaded bucket will make the front of the machine heaviest. Various attachments will change which end is heaviest. These same rules apply when loading and unloading the machine on a trailer.
-  **REDUCE SPEED** over rough or uneven ground to reduce the likelihood of 'rollover'.
-  **AVOID** turning on uneven ground. If you must turn, turn slowly, keeping the heavy end of the machine uphill.
-  **DO NOT** operate near ditches or embankments. The machine could turn over if a wheel or track goes over the edge of a drop-off or ditch or the edge caves in.

-  **USE CAUTION** when operating on wet grass; reduced traction could cause wheel slip.
-  **REMOVE** obstacles, such as rocks, tree limbs, etc., from the work area. Watch for ruts or bumps, as uneven terrain could overturn the machine. Tall grass can hide obstacles.
-  **OPERATE** at slow speed on uneven terrain. Place the pump selector valve in a slow (tortoise) position so you do not have to stop and shift the selector on uneven ground. If the machine becomes **UNSTABLE**, step clear. **NEVER** try to stabilize the machine by putting your foot on the ground.
-  **BE AWARE** of blind corners, shrubs, trees, or ends of fences that may obscure vision.
-  **NEVER** carry anyone on the machine or any of its attachments.
-  **BE AWARE** of the presence of children or animals when operating a machines.
-  **KEEP CHILDREN OUT OF THE WORKSITE** and under the watchful care of a responsible adult.
-  **DO NOT** allow children or unqualified persons to operate the machine.
-  **LOOK BEHIND** when reversing and look down for small children or animals.

Although the information stated here covers a wide range of safety subjects it is impossible to predict every eventuality that can occur under differing circumstances whilst operating this machine. No advice given here can replace 'good common sense' and 'total awareness' at all times, but will go a long way towards the safe use of your McConnel machine.

Remember: SAFETY is YOUR responsibility.



**FAILURE TO READ
THESE SAFETY RULES
PRIOR TO ANY MACHINE
OPERATIONS MAY LEAD
TO SERIOUS INJURY,
PROPERTY DAMAGE
OR DEATH.**

EMERGENCY STOP

OFF CHOKE ON

BATTERY ISOLATOR

NO ETHANOL BASED FUELS

HEARING PROTECTION SHOULD BE WORN

DANGER

TO MINIMIZE THE RISK OF ACCIDENTS:

- READ OPERATION MANUAL
- ALWAYS OPERATE WITH HEAVY END POINTED UP HILL
- ALWAYS CARRY LOAD LOW
- NEVER STEP OFF OPERATOR PLATFORM WITH LOAD RAISED
- NEVER JERK THE CONTROL LEVERS. USE A STEADY EVEN MOTION
- NEVER OPERATE THE CONTROL LEVERS UNLESS YOU ARE STANDING WITH BOTH FEET ON THE PLATFORM & FIRMLY HOLDING THE GRIP HANDLES

Max Flow to Attachment

Trenching Range

FLOW DIVIDER VALVE

Attachment Flow

ENSURE ATTACHMENT FLOW IS IN NEUTRAL BEFORE STARTING ENGINE

WARNING FAN

CAUTION

Secure locking pins before operating

DIESEL UNLEADED

THROTTLE

12V Power Max 5 Amp

DO NOT USE FLOW DIVIDER VALVE UNLESS PUMP SELECTOR IS IN ATTACHMENT POSITION

Hydraulic Oil HVI68

CAUTION
Allow engine to cool before refueling

Attachment Max Flow To Drive Wheels

PUMP SELECTOR

WHEEL DRIVE

ARM LIFT

BUCKET TILT

Attachment Flow 4 IN 1

OPEN

CLOSE

ENGINE WARNING LIGHT

OFF RUN START

ENGINE WARNING LIGHT

OFF RUN GLOW START

CHECK AIR CLEANER DAILY

YOU ARE THE PERSON RESPONSIBLE FOR YOUR SAFETY

ITEM # 021-999-072 DECAL SET DASH

Decal Maintenance

- Keep Decals clean using soap and water.
- Do not use harsh chemicals or spray directly using a High-Pressure washer.
- Replace Decals if missing or when they become hard to read or damaged.

The replacement Decal Set Part Number is 021-999-072.

SPECIFICATIONS & DIMENSIONS

Specifications: POWERLODA 325 & 325T Models

ENGINE			
Make	Kohler	Power	21 HP / 15.7kW
Model	ECH650-3025	Maximum Torque	50 Nm.
Oil Capacity	1.9L	Maximum angle of operation	25°
HYDRAULIC SYSTEM			
Hydraulic pumps	2	Hydraulic output	47 L/m
Pump sizes	11 & 4 cc	Hydraulic reservoir capacity	76L
Relief pressure (Aux)	3200psi (220bar)	Auxiliary hydraulic outlets	2
PERFORMANCE			
Fuel Tank Capacity	18L	Rated lift capacity	325kg SWL
Maximum travel speed	7.5km/hr		

Dimensions: POWERLODA 325 Model

DIMENSIONS			
A: Overall width	1040mm	H: Ground clearance	143mm
B: Overall length	1600mm	I: Dump height - std bucket	1450mm
C: Overall height	1200mm	J: Dump height - 4-in-1 bucket	1835mm
D: Max. height with 4-in-1 Bucket	2681mm	K: Reach - 4-in-1 fully raised	800mm
E: Turn with 4-in-1 Bucket	1300mm	L: Height to hinge pin	1940mm
F: Angle of departure	25 degrees	M: Machine width bucket	1050-1200mm
G: Wheelbase	800mm	Machine mass	854kg
Hydraulic Drive motors	4		

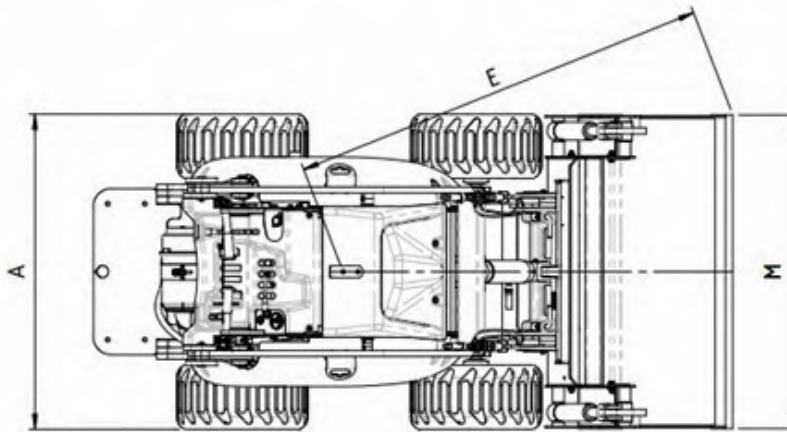

TOP VIEW

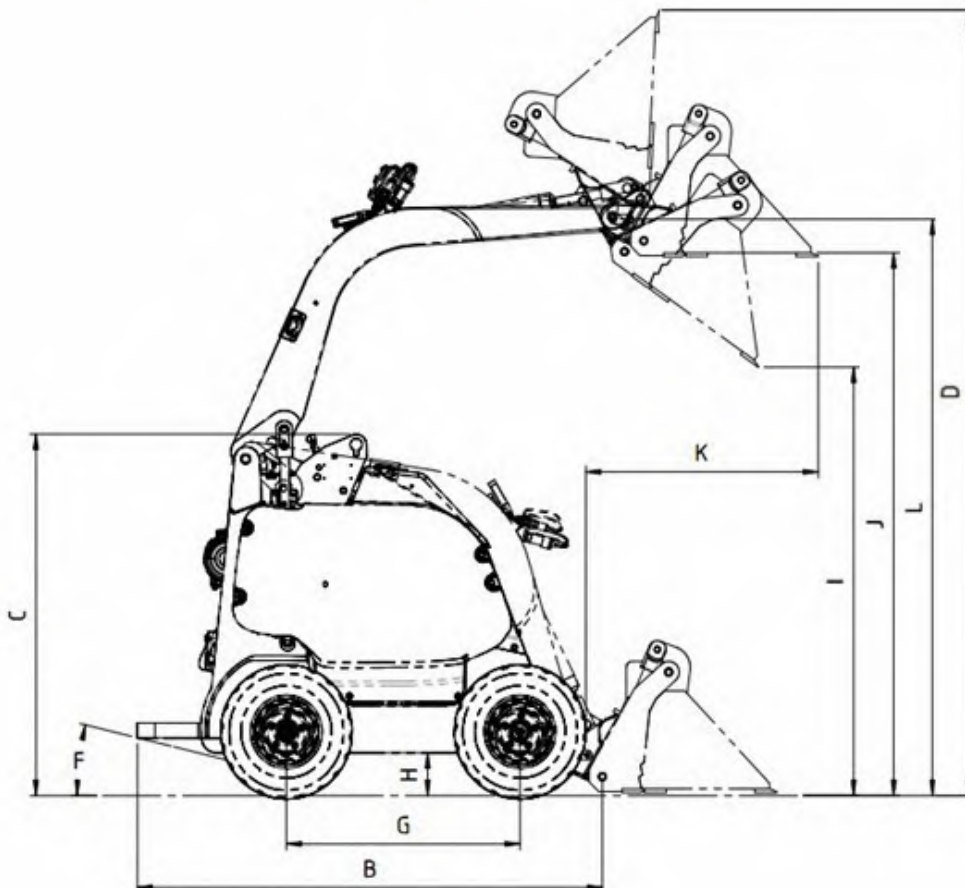

Dimensions: POWERLODA 325T Model

DIMENSIONS			
A: Overall width	1040mm	H: Ground clearance	143mm
B: Overall length	1600mm	I: Dump height - std bucket	1450mm
C: Overall height	1200mm	J: Dump height - 4-in-1 bucket	1835mm
D: Max. height with 4-in-1 Bucket	2681mm	K: Reach - 4-in-1 fully raised	800mm
E: Turn with 4-in-1 Bucket	1300mm	L: Height to hinge pin	1940mm
F: Angle of departure	25 degrees	M: Machine width bucket	1050-1200mm
G: Wheelbase	800mm	Machine mass	984kg
Hydraulic Drive motors	2		

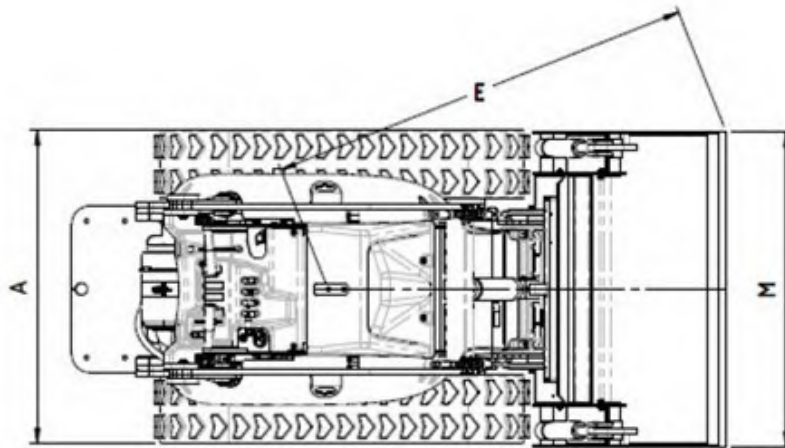

TOP VIEW

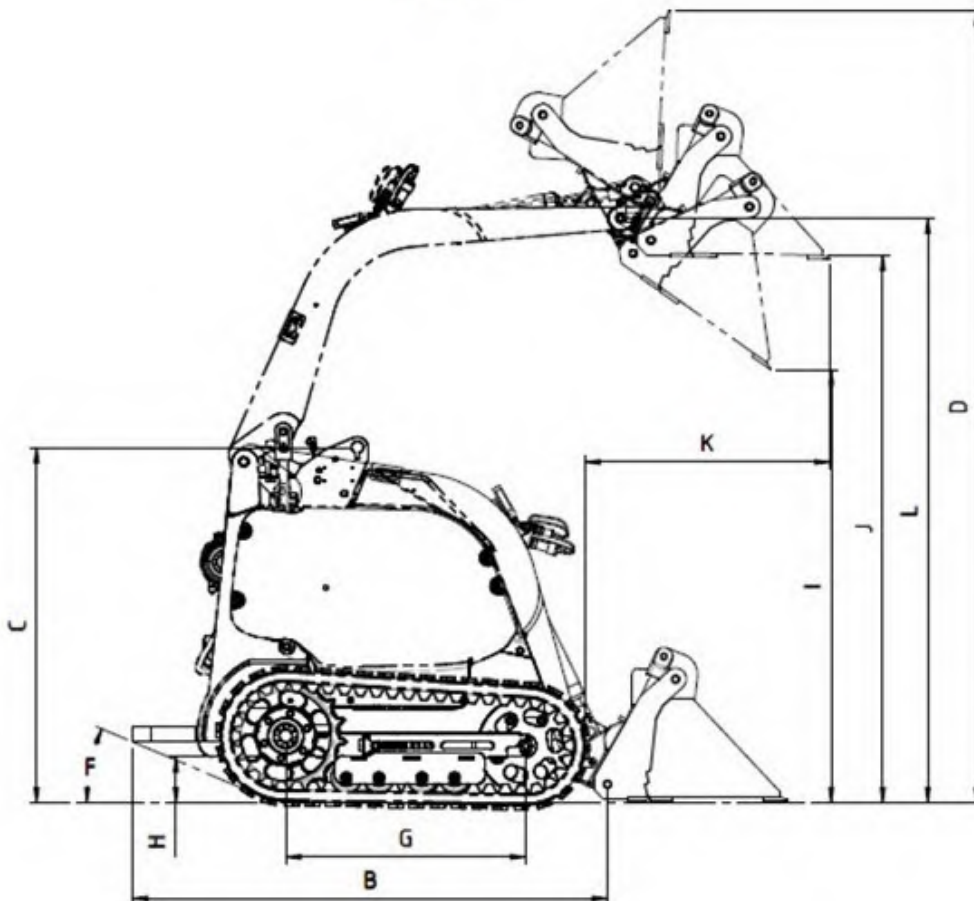

WARNING

All operators must read and fully understand the machine operation manual and engine manual before attempting to use the machine.

Machine Pre-Start Up Checks (Daily)

- **Check** fuel level
- fill to 60-70mm from the top (leave space for fuel expansion). **Do not overfill.**
- **Check** engine oil level (refer to the engine manual).
- **Remove** all debris from the machine.
- **Check** the air filter and clean if necessary.
- **Check** bushes and pins for wear.
- **Check** fans and cooling ventilation are clean and clear from obstruction.
- **Check** the machine for leaks (oil and fuel).
- **Check** the machine for any damaged and/or loose components.
- **Check** tyre pressures (POWERLODA 325 Models) : Correct tyre pressure is **36psi**.
Check track condition (POWERLODA 325T Models) : *refer to track maintenance tips.*

Adding Fuel

1. Position the machine on a firm level surface, lower the machine arms and turn off the engine (turn the ignition key off). Remove the key. **Allow the machine to cool down.**
2. Clean around the fuel tank cap and remove the cap. Use a funnel to add fuel to the fuel tank, fill until the fuel reaches 60-70mm below the top of the tank. This space is needed to allow the fuel to expand. **Do not fill the fuel tank completely full.**
3. Replace the fuel cap securely. Clean away any fuel that may have spilt.

Checking the Engine

Check the engine oil level using the dipstick (refer to your engine manual for details).

Remove Debris from the Machine

IMPORTANT: The engine will overheat if it is operated with a blocked grass screen, dirty or clogged cooling fins, and/or cooling shrouds removed. Use pressurized air to remove foreign matter from the radiator fins.

The hydraulic system will keep cooler if the machine is free from debris on the hydraulic tank and fittings.

1. Park the machine on a firm level surface, lower the machine arms and turn off the engine. Remove the key.
2. Check the air filter for debris. If required, wipe away debris before and during each use.
3. Debris can build up in the engine area. Clean any debris with a brush or blower before each use.

IMPORTANT: It is preferable to 'blow out' dirt and/or debris rather than wash it out. Do not put water directly onto the electrical system, ignition system, or radiator fins.

Tyres and Traction (325 Models)

WARNING! The POWERLODA tyres should be evenly filled with water. Failure to do so will affect weight distribution and drastically reduce the machine's stability and carrying capacity. Using incorrect tyre pressure will also reduce the machine's stability and carrying capacity.

Correct tyre pressure is 36psi.

IMPORTANT: In cold climates tyres must be filled with a mixture of water and antifreeze; the concentration required will depend on the particular climate in your region, contact your local tyre dealer for advice on this subject.

Various types of equipment are available to fill tyres with water. Hose fittings 610-000-016 and 610-000-019 can be purchased from McConnel through your local McConnel Dealer. You should also be aware that the tyres fitted to your machine may not be suitable for all work environments; a range of traction equipment is available to suit every application.

Track Maintenance Tips (325T Models)

1. At the start of each day, it is essential to examine the tracks for any signs of damage or wear.
2. Check for rocks or dirt that might have become lodged in the track mechanism, this can potentially cause premature damage or wear.
3. Regularly clean the undercarriage to prevent the accumulation of mud, gravel or other materials.
4. Ensure the proper tension of the tracks; when the machine is raised off the ground, there should be a sag of **10-20mm** in the middle of the track frame between the track and the middle roller. To do this, you must jack the machine off the ground, ensuring the tracks are not in contact with the ground. Adjust track tensioning bolts as required until the recommended gap is achieved.
5. Avoid overtightening the rubber tracks, this can reduce the lifespan of undercarriage components, damage internal bands of the rubber track, and increase the risk of track dislodgement. Excessive tension on the tracks can cause severe damage to the track components. **ALWAYS** tighten the tracks up to the mandatory measuring distance.
6. Conduct frequent checks on undercarriage components for signs of wear. Excessive wear on sprockets, idlers, and rollers can result in unnecessary wear on the rubber tracks. When installing new rubber tracks, ensure that undercarriage components are in good condition to support them adequately. Using new tracks on a worn undercarriage will significantly reduce their lifespan.
7. Machine operation also plays a role in the longevity of the track system. Continuous zero-turning, which is feasible with wheeled machines, can quickly deteriorate the track system of your machine. Exercise caution when turning to prolong the life of the tracks.

OPERATING INSTRUCTIONS

WARNING

Do not operate any control levers (including the auxiliary lever) unless you are standing with both feet on the platform and firmly holding the grip handles.

Ensure the auxiliary hydraulic lever is in the centre position before attempting to start the engine. The most common causes of issues such as "hard to start engine", "engine will not turn over fast enough", or "battery does not have enough power" starting problems is that the auxiliary lever has been left on or knocked into gear and the engine is trying to start under load.

Safety Recommendation for Operator

All Personnel operating and in proximity to the machine are required to strictly adhere to the Health and Safety Guidelines of the Work Site/Environment and must wear suitable Personal Protective Equipment (PPE).

It is recommended that the Operator consider PPE such as, but not limited to, Non-Slip & Enclosed Footwear, Safety Glasses and Hearing Protection.

It is advised that prior to performing any activity with the machine that a Risk Assessment is undertaken for identification, assessment (likelihood and consequence), determination of appropriate control treatments and residual risk analysis using an appropriate Risk Management Framework.

Work Area Checks

- **Ensure** ground conditions are firm and stable.
- **Ensure** sloping ground has been identified.
- **Ensure** holes have been identified and isolated.
- **Ensure** embankments have been marked.
- **Ensure** tree stumps, rocks, and other hazards have been identified.
- **Ensure** water courses (dams, ponds, rivers etc.) have been clearly marked.
- **Ensure** underground and aboveground services have been identified and isolated if necessary.
- **Ensure** site physical hazards have been identified.
- **Ensure** dust, noise, traffic, and other adverse conditions have been controlled.
- **Ensure** that persons not involved in the work are excluded from the area.
- **Ensure** underground utilities have been located.

MACHINE CONTROLS

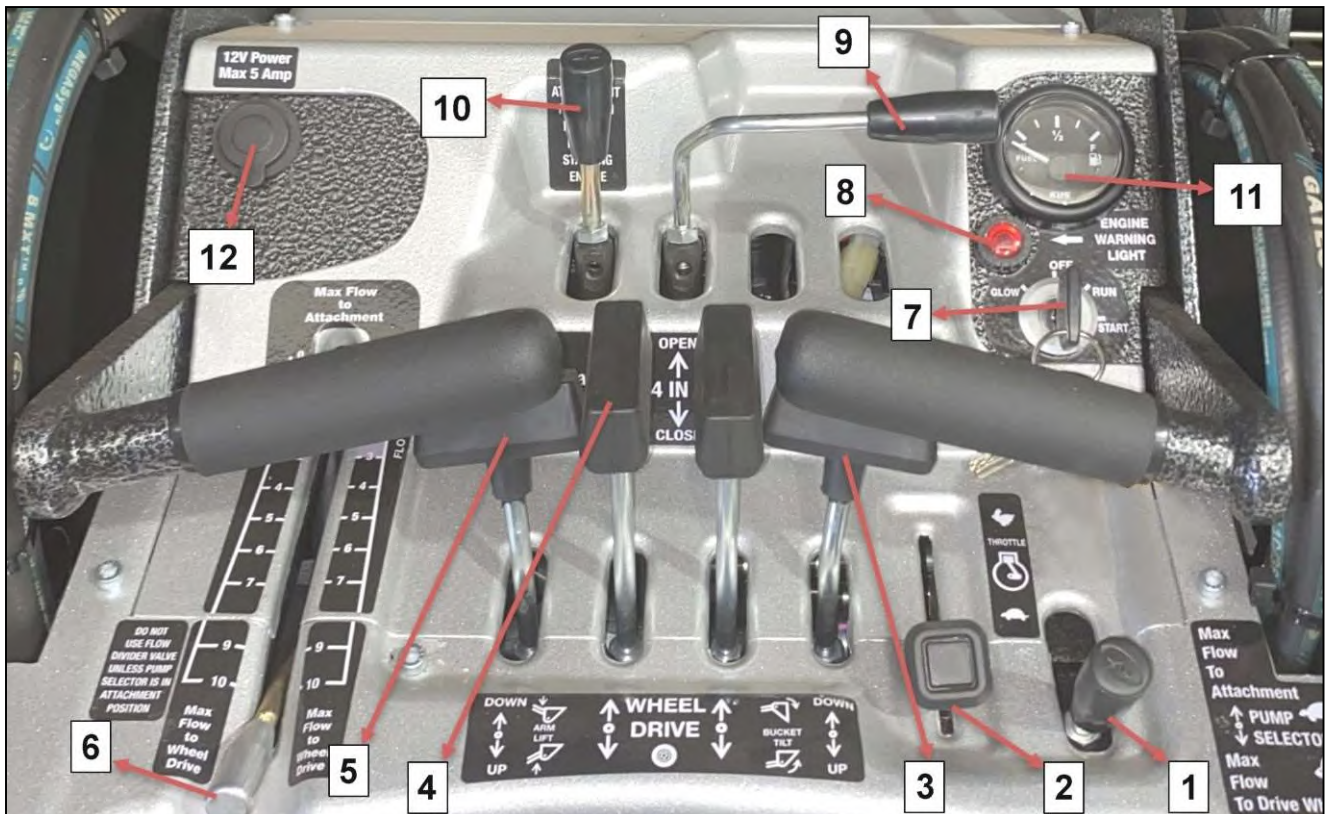

- | | | |
|-------------------------|-------------------------|--------------------------|
| 1) Pump Selector | 5) Arm Lever UP/DOWN | 9) 4-IN-1 Bucket Control |
| 2) Throttle Control | 6) Flow Divider Control | 10) Auxiliary Control |
| 3) Crowd/Tilt Lever | 7) Ignition Switch | 11) Fuel Gauge |
| 4) Drive Control Levers | 8) Engine Warning Light | 12) Power Socket (12v) |

1) Pump Selector

Use this to select the ground speed required for the attachment you're about to use.

When fast ground speed is required (bucket work) - push the pump selector lever forward to the HARE position (fast ground speed).

When attachment speed and power is required (trenching, post hole digging, etc.) - pull the pump selector lever rearward to the TORTOISE position (slow ground speed).

2) Throttle Control

Move control forward to increase engine speed and backward to decrease engine speed.

3) Crowd/Tilt Lever

To crowd/tilt the attachment forward: slowly push the tilt lever forward.

To crowd/tilt the attachment backward: slowly pull the tilt lever backward.

4) Drive Control Levers

To go forward: slowly push both drive control levers forward evenly.

To go backwards: slowly pull both drive control levers backwards evenly.

To go straight: apply equal pressure to both drive control levers.

To turn: decrease pressure on drive control lever closest to the direction you want to turn; *the further you move the drive control levers in either direction the faster the machine will move in that direction.*

To slow or stop: move, or release the drive control levers into neutral. If released, the control levers should automatically return to neutral - if they don't, see your service technician.

The machine can turn on the spot by applying equal power to each drive lever in opposing directions.

5) Arm Lever UP/DOWN

To lower the machine arms: slowly push the arm lever forward.

To raise the machine arms: slowly pull the arm lever backwards.

6) Flow Divider Control

In its normal operating position (at '10'), no flow division is taking place (all the oil is going to the hydraulic drive motors). Moving the lever forward diverts oil flow to the attachment, and less oil is available to the tracks and arms. This allows for a greater concentration of power where it is needed most. At position '0', all the oil is being diverted away from the tracks.

The flow divider is mainly used for trenching, rotary hoeing, scrub clearing and stump grinding, where the attachment needs to have as much power as possible, and ground speed is optional. When trenching, rotary hoeing and scrub clearing the flow divider can be used to set a consistent ground speed to match the conditions, rather than toggling the drive levers which can overheat the hydraulic oil.

7) Ignition Switch

The ignition switch starts and stops the engine. For starting instructions refer to the engine manufacturer's manual.

Starting the Engine

Stand on the platform and move the auxiliary hydraulics lever to the neutral position.

Follow instructions on starting the engine as detailed in the engine manufacturer's manual.

Stopping the Engine

Move the throttle to the idle position and turn the key off (turn the key to the OFF position by rotating it counterclockwise). Refer to the engine manual.

NOTE: If the engine has been working hard or is hot, let it idle for a minute or two before turning the ignition key off; this helps cool the engine before it is stopped.

In an emergency; turning the ignition key OFF will stop the engine.

8) Engine Warning Light

The engine warning light lets you know if there is a problem with the engine. It notifies you if the oil or coolant temperature (if applicable) reaches above a certain temperature and if the alternator stops charging.

9) 4-IN-1 Bucket Control

The 4-IN-1 bucket lever opens and closes the bucket: push the lever forward to open the bucket and pull the lever backwards to close the bucket. When you let go of the lever, it will return to the centre position, and the bucket should be held in that current position.

10) Auxiliary Control

The auxiliary hydraulic levers allow you to alter the direction of rotation of hydraulic-driven attachments or stop them completely.

Attention: Ensure the auxiliary hydraulic levers are in their neutral positions before starting the engine. Aside from starting difficulties the attachment may move during start.

To operate the attachment in a forward direction, slowly pull the auxiliary lever rearward. To operate the attachment in the reverse direction, slowly push the auxiliary lever forward.

11) Fuel Gauge

Shows the amount of fuel in the tank.

12) Power Socket (12v)

This allows temporary attachments such as a safety beacon to be powered by the machines battery.

Stopping the Machine

To stop the machine, move the drive control lever to neutral, lower the machine arms to the ground, and turn the ignition key to the OFF position to stop the engine.

If the machine is parked on a slope always chock the wheels/tracks.

⚠ WARNING

Always remove the ignition key if leaving the machine unattended to avoid risk of attempted use by unauthorised persons.

Moving a Non-Functioning Machine

The best way to move a non-functioning machine is by forklift or crane. Alternatively, pushing or towing the machine without using the engine is also possible. Contact your McConnel Dealer for further advice on this subject.

Using Cylinder Locks

Normal maintenance should be performed with the machines arms lowered. If maintenance or repairs require the machines arms to be raised, the cylinder lock provided with the machine must be used.

⚠ WARNING

Machine arms may lower when in the raised position. To avoid this hazard, always install the cylinder locks provided or use a safety stand specifically designed for this purpose. Contact your McConnel Dealer for further advice on this subject.

ATTACHMENTS

IMPORTANT: Use only McConnel-approved attachments on the machine. Attachments can change the stability and operating characteristics of the machine, and the warranty may be voided if used with unapproved attachments.

IMPORTANT: Before connecting any attachments to the machine, make sure the mount plates are free of dirt or debris. Dirt built up in the bottom of the receiver plate will become compacted and cause problems.

Connecting Attachments

1. Move the pump control lever to the slow (tortoise) position.
2. Slowly push the attachment tilt lever forward to tilt the Mount plate forward.
3. Position the Mount plate into the upper lip of the attachments receiver plate.
4. Raise the machines arms while tilting back the Mount plate simultaneously.
5. **IMPORTANT:** The attachment should be raised enough to clear the ground, and the Mount plate should be tilted all the way up.
6. Turn the ignition key OFF to stop the engine.
7. Engage the attachment lock pins (the lock pins should go down 15mm as they turn). **Note:** Lock pins are located on the outer edge of the Mount plate and should be turned towards the inside to engage.

Note: Proceed to the next step if auxiliary hydraulics are required with attachment.

8. **IMPORTANT:** Ensure all foreign matter is cleaned from the hydraulic connections before making connections. Use a clean rag/cloth to remove dirt or any other contaminants. **DO NOT** let water enter the Hydraulic System.
9. With the engine turned OFF, move the auxiliary hydraulics lever forward, backwards, and back to the neutral position to relieve any hydraulic pressure at the hydraulic couplers.
10. Remove the protective plugs from the hydraulic couplers on the machine. Connect the plugs together to prevent contamination during operation.
11. Slide the collar back on the hydraulic coupler and connect attachment couplers to machine couplers. There will be two connections to make.
12. Confirm that the connection is secure by pulling on the hoses.

Disconnecting Attachments

1. Lower the attachment to the ground or onto a trailer.
2. Turn the ignition key OFF to stop the engine.
3. Move the auxiliary hydraulics lever forward, backwards, and back to the neutral position to relieve any hydraulic pressure at the hydraulic couplers.
4. Slide the collar back on the hydraulic coupler and disconnect the attachment hose couplers from the machine couplers. (**Note:** If difficulty is experienced, return to step 3 and repeat).
5. **IMPORTANT:** Connect the attachment hoses together to prevent contamination during storage.
6. Install the protective covers onto the machines hydraulic couplers.
7. Disengage the Mount plate lock pins by turning them to the outside.
8. Start the engine, tilt the Mount plate forward and back the machine away from the attachment.

TRANSPORT & SECURING

⚠️ WARNING Read the Trailer manual before loading or unloading the machine

IMPORTANT: Ensure the gross weight of the machine with attachments does not exceed the Trailer's rated capacity or the combined Gross mass of the Tow vehicle and Trailer.

IMPORTANT: Observe local legislation when operating on roadways.

IMPORTANT: Always use the procedure below when transporting the machine on a trailer.

NEVER load or unload the machine on the Trailer unless the Trailer is attached to a vehicle.

ALWAYS climb the ramps with the heavy end of the machine uphill. With heavy attachments like the trencher attached to the machine, drive the machine up the ramps and reverse down the ramps. When no attachment is fitted to the machine, reverse the machine up the ramps and drive down the ramps.

The bucket, post hole digger and trencher attachment should **ALWAYS** be positioned in their designated positions on the Trailer. This helps ensure that the weight is distributed correctly on the Trailer.

Always ensure the load is positioned so that there is more weight forward of the trailer axle than behind the axle. Too much weight behind the axle may cause the rear of the vehicle to become too light. *Refer to the motor vehicle manufacturers recommendations.*

When in position on the Trailer:

- Lower the machines arms.
- Turn the key OFF to stop the engine.
- Remove the key.
- Secure machine to Trailer

When towed by a vehicle not fitted with an electric trailer brake controller, engage the manual braking system by lifting the manual override stopper on the tow coupling (single-axle Trailer only).

SECURE the machine to the Trailer with chains or straps.

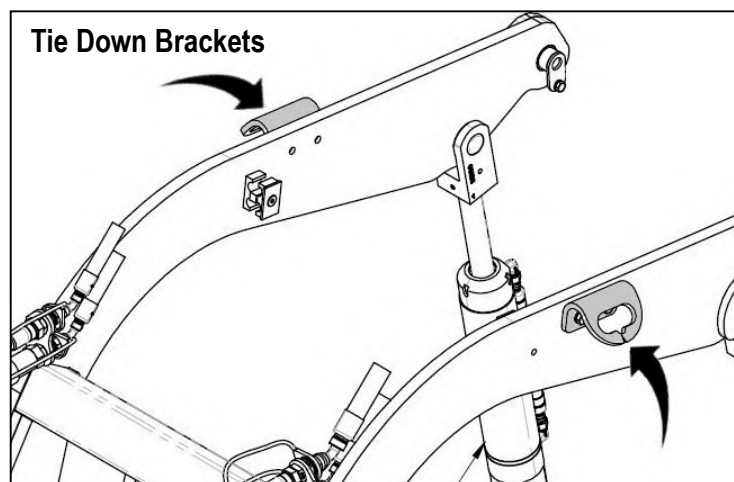

Note: machines may have strap slots in arms in place of tie down brackets illustrated here.

MAINTENANCE

WARNING

Maintenance should be performed in a clean safe location on a firm level site.

It is essential to maintain the engine as detailed in the engine manual; *refer to your log book service manual for this information.*

Refer to the 'Pre-start Up' section for maintenance that should be completed before starting the machine (each and every time).

Air Filter

IMPORTANT: The air filter is of extreme importance. It ensures the air entering the engine is clean. Blocked or damaged air filters can significantly reduce engine life. The time interval between air filter changes will depend on the operating conditions. Change of air filter is recommended instead of cleaning the air filter.

In dusty conditions, check air filters daily and replace them if necessary.

NEVER blow out your air filter with compressed air.

If the filter or filter housing is damaged, stop engine immediately and replace the damaged components. Failure to stop work immediately when the air filter or housing is damaged could permanently damage the engine.

Bushes & Pins

The machine is equipped with premium self-lubricating bushes and chrome pins for the arm joints. These bushes are wearing parts and require regular inspection (once a week).

To check the condition of the bushes:

1. Remove Attachment from the front of the machine.
2. Raise the arms until the Mount plate is at waist height.
3. Grab the Mount plate and wriggle 'back and forth' to try to identify any movement in any of the joints in the Mount plate.
4. Grab the arms and wriggle 'up and down' to detect any movements in joints in the arms.

Contact your McConnel Dealer for replacements if any bushes show signs of wear.

If not attended to, a little wear quickly becomes a big and expensive problem. Replacing the bushes is a simple task, the issue is easily fixed if detected in time.

Engine Oil

Refer to the engine manual for required oil types, crankcase capacity and viscosity.

It is recommended to change the engine oil every **100 hours**.

IMPORTANT: Check the oil daily.

Changing Oil Filter

Refer to the engine manual.

Hydraulic System

The hydraulic oil type and viscosity are the most critical components of a hydraulic system. Cleanliness is paramount; volume is next. However, if no leaks are visible, it is better not to remove the cap except when you suspect the volume may have changed.

Valvoline HVI68 is recommended for normal use.

Valvoline HVI100 is recommended for machines permanently fitted with a concrete grinding head.

Battery

Always keep the battery clean and fully charged. Use a paper towel to clean the battery case. If the battery terminals are corroded, clean them with a solution of 4 parts water and 1 part baking soda. To reduce corrosion, apply a coating of battery terminal protector.

Voltage: 12v, 380 Cold Cranking Amps.

If the battery becomes flat or machine is not used for a prolonged period, charge the battery using an external battery charger. Do not rely on the engine's charging system to recharge a battery; it is only meant to maintain charge in a good battery.

MAINTENANCE SCHEDULE



New Machines

After the first **50 hours**

- Replace engine oil & filter.
- Check and reset hydraulic pressures.

Service Schedule

Component	Maintenance Task	Frequency					
		DAILY	25HRS	50HRS	100HRS	250HRS	500HRS
Air Cleaner	Check element and remove dust, replace element if necessary	•					
Engine Crankcase	Check oil level	•					
Hydraulic System	Check fluid levels. Check for signs of leakage on connections.	•					
Machine Inspection	Check for loose, worn or damaged components; replace where necessary.	•					
Load Arm Pivot Pins and Bushes	Check for wear; replace where necessary.		•				
Fuel supply	Check for fuel leaks. Check for perished supply lines.			•			
Battery	Clean terminals. Check electrolyte levels.			•			
Wheels and Tyres	Check pressures. Check wheel nut torques.			•			
Tracks	Check condition/tension.						
Hydraulic Cylinders	Check for signs of internal/external leakage.			•			
Operation/function	Check machine operation and functions.			•			
Air Filters	Replace air cleaner elements.				•		
Fan Belt	Inspect for wear and/or damage and check belt tension.				•		
Fuel Filters	Replace fuel filter.				•		

Service Schedule (continued)

Component	Maintenance Task	Frequency					
		DAILY	25HRS	50HRS	100HRS	250HRS	500HRS
Engine Oil/Filter	Replace engine oil and filter.				•		
Fuel Tank	Drain tank and remove sediment.					•	
Hydraulic Reservoir	Replace hydraulic oil and filters. Remove sediment from tank.						•
Fuel Pump timing	Adjust injection pump timing.						•
Cooling System	Drain coolant and flush coolant system.						•
Valve clearance	Adjust intake and exhaust valve clearances.						•
Spark Plugs	Replace spark plugs and set gap.						•

TROUBLESHOOTING

Problem	Possible Causes	Corrective Action
Starter does not crank	Battery dead. Electrical connections are corroded or loose. Faulty ignition switch.	Charge the battery. Check electrical connections for good contact and condition. Replace the ignition switch.
Engine will not start, hard to start or fails to keep running	Auxiliary hydraulics lever is not in neutral position. Fuel tank is empty. Air cleaner is dirty. Dirt in fuel filter. Dirt, water, or stale fuel in fuel tank and/or fuel system.	Move the auxiliary lever to the neutral position. Fill the tank with appropriate fuel. Clean or replace the air cleaner elements. Replace the fuel filter. Drain fuel tank and filter and replace fuel. Contact your local McConnel dealer.
Engine loses power	Engine load is excessive. Air cleaner is dirty. Oil level in crankcase is low. Cooling fins and air passages under engine blower housing are blocked. Dirt in fuel filter. Dirt, water, or stale fuel in the fuel tank or fuel system.	Reduce ground speed. Clean or replace the air cleaner elements. Add oil to crankcase. Remove obstruction from cooling fins and air passages. Replace fuel filter. Drain the fuel tank and filter and replace fuel. Contact authorised dealer.
Engine overheats	Engine load is excessive. Oil level in crankcase is low. Cooling fins and air passages under engine blower housing are blocked.	Reduce ground speed. Add oil to crankcase. Remove obstruction from cooling fins and air passages.
Abnormal vibration	Engine mounting bolts loose. Engine mounts are broken.	Tighten engine mounting bolts. Replace engine mounts.
Machine does not drive	Hydraulic fluid level is low. Hydraulic pump drive coupler is loose or broken. Pump and/or wheel motor is defective or damaged. Control valve defective or damaged. Relief valve defective or damaged.	Add hydraulic fluid to reservoir. Contact your McConnel dealer. Contact your local McConnel dealer. Contact your local McConnel dealer. Contact your local McConnel dealer.



McConnel Limited, Temeside Works, Ludlow, Shropshire SY8 1JL. England.
Telephone: 01584 873131. Facsimile: 01584 876463. www.mcconnel.com