

Publication 474
April 2005
Part No. 41570.74
Revision 28.06.06



PT6, PT8 & PT9 PASTURE TOPPERS

Standard & Offset Models

Operation & Parts Manual



McCONEl

IMPORTANT

VERIFICATION OF WARRANTY REGISTRATION



DEALER WARRANTY INFORMATION & REGISTRATION VERIFICATION

It is imperative that the selling dealer registers this machine with McConnel Limited within 7 days of delivery to the end user – failure to do so may affect the validity of the machine warranty.

To register a machine go to the McConnel Limited web site at www.mcconnel.com, log on to '**Dealer Inside**' and select the '**Machine Registration button**' which can be found in the Service Section of the site. Confirm to the customer that the machine has been registered in the section below.

Should you experience any problems registering a machine in this manner please contact the McConnel Service Department on 01584 875848.

Registration Verification

Dealer Name:
Dealer Address:
Customer Name:
Date of Warranty Registration:/...../..... Dealer Signature:

NOTE TO CUSTOMER / OWNER

Please ensure that the above section above has been completed and signed by the selling dealer to verify that your machine has been registered with McConnel Limited.



McCONNEL LIMITED

**Temeside Works
Ludlow
Shropshire SY8 1JL
England**

**Telephone: 01584 873131
www.mcconnel.com**

E.C MACHINERY DIRECTIVE
98/37/EC

CE DECLARATION OF CONFORMITY

We hereby certify that the machinery stipulated below complies with all the relevant provisions of the EC Machinery Directive and the National Laws and Regulations adopting this Directive.

Machine Description.... Mounted In-Line Toppers
Make/ ModelPT6, PT8 & PT9

Manufacturer: LSM Engineering LTD
Address: Ballymacken, Portlaoise, Co. Laois. (IRELAND)

Is in conformity with the following other Directives and Standards;

Directive 98/37/EC – Machinery Directive
Directive 93/9 EEC – “CE Marking Directive”

Harmonized Standards applied;

EN 292 pt1:1991 - Safety of Machinery - Basic concepts, general principles for design
EN 292 pt2:1991 - Safety of Machinery - Technical Principles and specifications
EN 60204-1:1993 - Safety of Machinery - Electrical equipment of machines
EN 1050:1996 - Safety of Machinery - Principle of Risk Assessment

Signed *Noel Graham*
Date February 2004
Name Noel Graham
Position Production Manager

We reserve the right to make changes or improvements at any time without incurring any obligation to make such changes on products sold previously.

LIST OF CONTENTS

Page No.

OPERATION SECTION

INTRODUCTION	1
Features	2
Specifications	3
SAFETY SECTION	4
Safety Information	4
Machine Decals - Location	8
Machine Decals – Identification	9
MACHINE FITTING	10
Tractor Requirements	10
Tractor Preparation	10
Tractor Attachment	11
Driveline Attachment	11
OPERATION	13
Cutting Speed	13
Cutting Height	14
Cutting Height Adjustment	14
Transportation & Work Positions – <i>Offset Model</i>	15
Starting and Stopping the Machine	16
Worksite Checks and Procedures	16
MAINTENANCE	18
Lubrication Points	18
Gearbox Lubrication	18
Driveline Lubrication	19
Driveline Shield Removal	20
Blade Servicing	20
Blade Sharpening	21
Blade Removal	21
Blade Carrier Removal	21
Blade Carrier Installation	21
MACHINE REMOVAL	17
Detachment of the Machine	17
Machine Storage	17
TROUBLESHOOTING	22
General Troubleshooting	22
PTO Shaft Troubleshooting	23
Gearbox Troubleshooting	24

PARTS SECTION

Main Frame – <i>PT6 Model</i>	27
Main Frame – <i>PT8 & PT9 Standard Models</i>	28
Main Frame – <i>PT8 Offset Model</i>	29
Chassis – <i>PT8 Offset Model</i>	30
Blade Carrier Assembly – <i>PT6 Model</i>	31
Blade Carrier Assembly – <i>PT8 & PT9 Standard Models</i>	32
Blade Carrier Assembly – <i>PT8 Offset Model</i>	33
Machine Decals	34

INTRODUCTION

McCONNEL PT SERIES MOWERS - Medium Duty Pasture Toppers

Although designed primarily for the 'topping' of agri pastures the machines may also be used for 'topping' sports grounds and local council areas. These machines should never be used for topping set-aside.

Our machines are designed with care and built with quality materials by skilled workers. Proper assembly, maintenance and operating practices, as described in this manual, will help the owner/operator get years of satisfactory service from the machine.

The purpose of this manual is to familiarise the owner/operator with the machine, and offer guidance to ensure it is operated both safely and correctly for its designated task.

The parts section is designed to familiarise the owner/operator with replaceable parts on the machine - this section provides exploded assembly drawings of the machines components, illustrating each piece and identifying its part number.

Careful use, timely service and the fitting of genuine parts will save extensive repairs and costly downtime. The operation and maintenance sections of the manual train the owner/operator how to work the machine correctly and attend to appropriate maintenance tasks. The trouble shooting guide helps diagnose difficulties with the machine and offer solutions to any problems.

Safety is of primary importance to the owner/operator and to the manufacturer. The first section of this manual includes a list of safety messages that, if followed, will help protect the operator and bystanders from injury or death. Many of these messages will be repeated throughout the manual. The owner/operator/dealer should know these messages before attempting assembly or maintenance and to be aware of the hazards associated with the operation of this machine during assembly, use, and maintenance.



FEATURES

PT6 MODEL

- Three point linkage mounted.
- Working width of 1.8m.
- Cutting height from 24.2mm to 114.2mm.
- 540-RPM PTO Shaft drive.
- Shear pin protection.
- Single rotor.
- Semi-Offset cutting position.
- Easy height adjustment.

PT8 MODEL

- Three point linkage mounted.
- Working width of 2.5m.
- Cutting height from 24.2mm to 114.2mm.
- 540-RPM PTO Shaft drive.
- Shear pin protection.
- Twin rotors.
- Easy height adjustment.

PT8 OFFSET MODEL

- Three point linkage mounted.
- Working width of 2.5m.
- Cutting height from 24.2mm to 114.2mm.
- 540-RPM PTO Shaft drive.
- Shear pin protection.
- Twin rotors.
- Easy height adjustment.
- Right hand offset cutting.
- Safety Breakaway System.

PT9 MODEL

- Three point linkage mounted.
- Working width of 2.75m.
- Cutting height from 24.2mm to 114.2mm.
- 540-RPM PTO Shaft drive.
- Shear pin protection.
- Twin rotors.
- Easy height adjustment.

SPECIFICATIONS

Description	PT6 Model	PT8 Model	PT9 Model
Cutting Width	<i>1.8m</i>	<i>2.5m</i>	<i>2.75m</i>
HP Requirement	<i>35 HP</i>	<i>40 HP</i>	<i>45 HP</i>
Weight	<i>290 Kg</i>	<i>480 Kg</i>	<i>509 Kg</i>
Attachment	<i>3-Point Linkage</i>	<i>3-Point Linkage</i>	<i>3-Point Linkage</i>
Cutting Height	<i>24.2 – 114.2mm</i>	<i>24.2 – 114.2mm</i>	<i>24.2 – 114.2mm</i>
Cutting capacity	<i>12mm</i>	<i>12mm</i>	<i>12mm</i>
Overall Width	<i>2.05m</i>	<i>2.64m</i>	<i>2.94m</i>
Overall Length	<i>2.15m</i>	<i>1.89m</i>	<i>1.89m</i>
PTO Speed	<i>540 rpm</i>	<i>540 rpm</i>	<i>540 rpm</i>
Protection	<i>Shear Bolt</i>	<i>Shear Bolt</i>	<i>Shear Bolt</i>
Blade Carriers	<i>1</i>	<i>2</i>	<i>2</i>
No. of Rotors	<i>1</i>	<i>2</i>	<i>2</i>
Blade Tip Speed	<i>4500 m/min</i>	<i>4140 m/min</i>	<i>4620 m/min</i>
Blade Overlap	<i>n/a</i>	<i>90mm</i>	<i>90mm</i>
Skids	<i>2</i>	<i>2</i>	<i>2</i>

SAFETY

There are obvious and potential hazards in the operation of this mower. REMEMBER! This machine may often be operated in brush of up to ½" (12mm) diameter. The blades of this mower can propel objects for a great distance at very high speeds. Serious injury or even death may occur unless care is taken to ensure the safety of the operator, bystanders or passersby in the area.

KEEP CLEAR

Before attempting to operate this machine the owner and the operator should read, understand and heed the following information. Serious injury or death may occur if the safety advice given here is ignored. In addition to this safety advice, good 'common sense' will go a long way towards avoiding hazardous situations and reduce the risk of danger.

DANGER



Rotary mowers are capable under adverse conditions of throwing objects great distances (100 yards or more) and causing serious injury or death.

STOP MOWING IF PASSERSBY ARE WITHIN 100 YARDS (91 metres) unless:

- Front and rear deflectors, chain guards or bands are fitted and are in good workable condition.
- Mower sections or wings are running close to, and parallel to, the ground without exposed blades.
- Passersby are outside the existing thrown-object zone.
- All areas have been thoroughly inspected and foreign materials such as rocks, cans, glass and general 'risk' debris have been removed.

NOTE: Where grass and weeds are high enough to obscure debris that could be struck by the blades, the area should be inspected and debris removed, mowed at an intermediate height, and re-inspected closely to remove any remaining debris and mowed again at the desired final height. *(In addition to the safety aspect of this procedure it will also reduce wear and tear on the mower drivetrain, spread cut materials better, eliminate 'streaking' and make the final cut more uniform).*

DANGER



All guards, bands, deflectors, driveline shields and gearbox shields should be used and maintained in good working condition at all times. They should be carefully inspected daily for missing or broken cable, chain links, shields or guards. Missing, broken or worn items must be replaced before attempting to use the machine to reduce the possibility of injury from thrown objects or entanglement.

WARNING



Extreme care should be taken when operating near loose objects such as gravel, rocks, wire and other debris. Foreign objects should be removed from the work site or avoided to prevent machine damage and/or bodily injury or even death.

DANGER



The rotating parts of this machine have been designed and tested for rugged use. However, they could fail upon impact with heavy solid objects such as steel guardrails and concrete abutments. Such impact could cause the broken objects to be thrown outward at very high velocities. To reduce the possibility of property damage, serious injuries, or even death, never allow the cutting blades to contact such objects.

WARNING The operator and all support personnel should wear 'hard hats', 'safety shoes' and 'safety glasses' at all times for protection from injury by falling objects and items thrown by the machine.



DANGER Operate the mower only with a tractor equipped with an approved 'roll over protection system (ROPS). Always wear your seat belt. Serious injury or even death could result from falling off the tractor – particularly during a turnover when the operator could be pinned under the ROPS or the tractor.



WARNING Before leaving the tractor seat always engage the brake and/or set the tractor transmission in parking gear. Disengage the PTO, stop the engine, remove the key and wait for all moving parts to stop. Place the tractor shift lever into a low range or parking gear to prevent the tractor from rolling. Never mount or dismount a moving tractor. Operate the tractor controls from the tractor seat only.



WARNING Many varied objects such as wire, cable, rope or chains can become entangled in the operating parts of mower head. These items could then swing outside the housing at greater velocities than the blades. Such a situation is extremely hazardous. Inspect the cutting area for any such objects and remove prior to mowing. Never allow the cutting blades to contact such items.



DANGER Be particularly careful in transport. Turn curves or go up hills only at a low speed and at a gradual steering angle. Ensure that at least 20% of the tractor's weight is on the front wheels to maintain safe steering. Slow down on rough or uneven surfaces.



WARNING Ensure that all necessary signs are correctly displayed, and clearly visible, when working or transporting on or near a public highway. *(Contact your Local Highway Authority to ensure you are fully conversant with your responsibilities on this subject).* Use flashing warning lights when working or transporting on or near a public highway to indicate to other road users a potential hazard. Always abide by local traffic regulations.



WARNING Ensure all moving parts of the machine are regularly inspected for wear and replaced with authorised service parts if an excessive amount of wear is present. Always use shear bolts recommended by McConnel.



WARNING Ensure the machine is regularly inspected for loose fasteners, worn or broken parts and loose or leaky fittings. Ensure all pins are fitted with cotter pins and washers. Serious injury can result from failure to maintain this machine in good working order.



DANGER Never leave the machine in the raised transport position – the machine could fall inadvertently and cause injury or death to anyone who might be under the machine.



DANGER Never clean or adjust PTO driven equipment with the tractor engine running. Kill the engine and pocket the key before attempting any maintenance on the machine.



DANGER Never allow riders on either the tractor or the mower - falling off can kill.



DANGER Never allow children to operate, ride on, or come close to the mower or the tractor.



DANGER Never work under the mower deck, framework or any raised component unless the mower has been securely supported and blocked using suitable substantial items to prevent sudden or inadvertent falling which could cause serious injury or even death.



WARNING Never operate the tractor and mower until you have read, and fully understood, the operation manual and are conversant with all the safety instructions stated here. Ensure you read all safety messages found on both the tractor and the mower.



WARNING Ensure you maintain all safety decals in good readable condition. If a decal should for any reason become illegible order a replacement immediately before permitting the machine to be used.



DANGER Never run a tractor engine in a closed building without adequate ventilation. The exhaust fumes can be hazardous to your health.



DANGER Ensure that a PTO shield is installed when using PTO-driven equipment and always replace the PTO shield if damaged.



CAUTION PROLONGED EXPOSURE TO LOUD NOISE MAY CAUSE PERMANENT HEARING LOSS ! Tractors with or without mowers attached can often be noisy enough to cause permanent or partial hearing loss. We recommend that hearing protection be worn at all times when the noise level experienced in the operator's position exceeds 80db. Noise in excess of 85db on a long-term basis can cause permanent total hearing loss. Where the tractor is fitted with a 'quiet cab' it is recommended that the windows are kept closed at all times whilst operating this machine.



In addition to the safety messages stated here the machine is fitted with warning decals that are designed to bring to the attention of the operator the potential dangers that exist whilst using the machine. However, these cannot replace correct proper training and total awareness of all the dangers involved in using a machine of this type, and the nature of the work it does. **BE ALERT, PAY ATTENTION – SOMEONE'S LIFE MAY BE AT STAKE !**

WHEN THIS SYMBOL IS DISPLAYED:



- **BE ALERT**
- **PAY ATTENTION**
- **SOMEONE'S LIFE IS AT STAKE**

MACHINE DECALS - Location

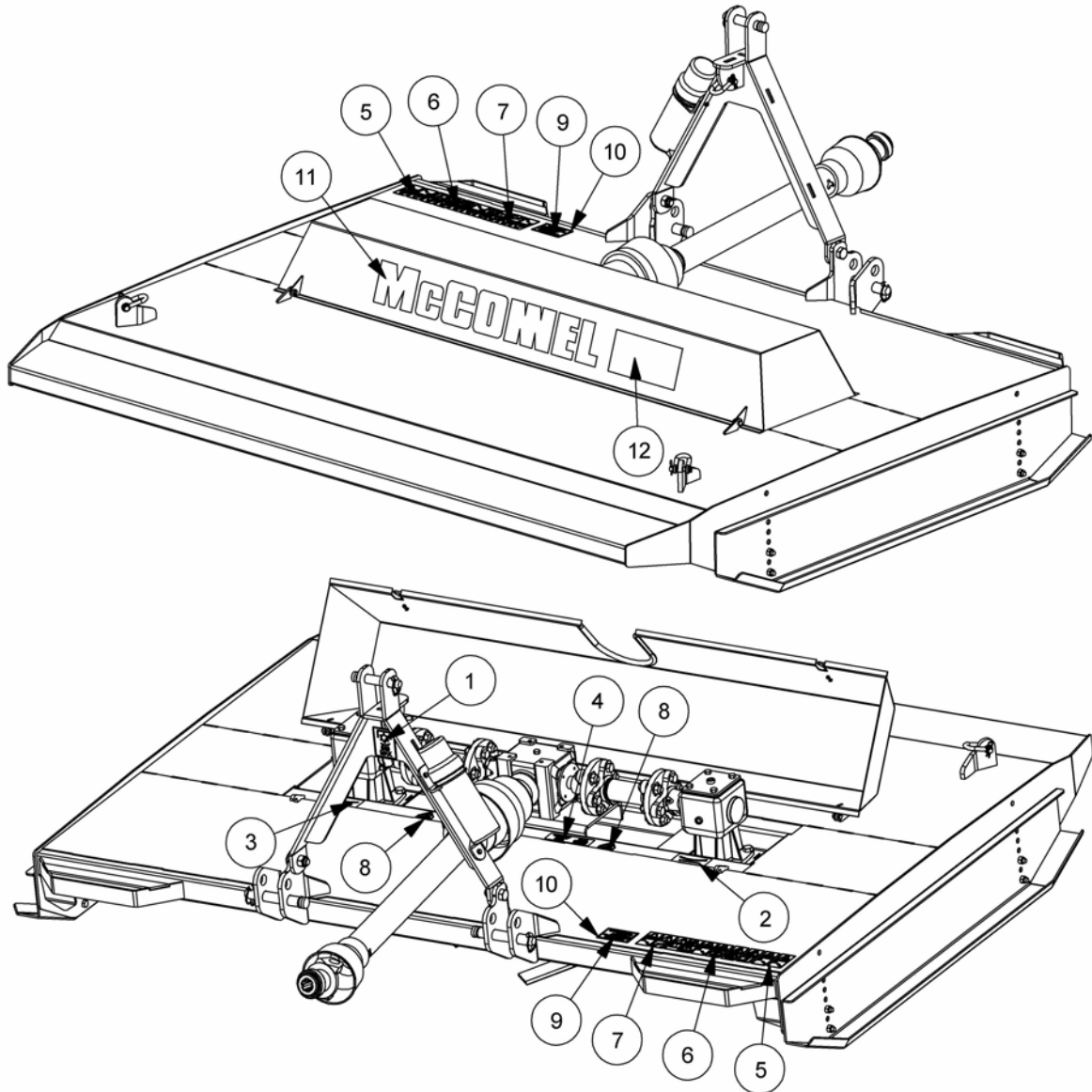

REF.	QTY.	PART NO.	DESCRIPTION	TYPE	
1	1	09.811.04	540 RPM PTO SPEED	WARNING	
2	*	1	D137	CCW BLADE ROTATION	INSTRUCTION
3	*	1	D138	CW BLADE ROTATION	INSTRUCTION
4	*	1	D132	BLADE TIMING	INSTRUCTION
5	1	09.821.29	COMBINED EURODECAL	WARNING	
6	1	09.821.30	COMBINED EURODECAL	WARNING	
7	1	09.821.34	COMBINED EURODECAL	WARNING	
8	*	2	09.810.02	GREASE (40 HOURS)	INSTRUCTION
9	1	1335246	SERIAL No. PLATE	PLATE	
10	4	7103230	POP RIVET	PLATE FIXING	
11	1	1290649	McCONNEL (SILVER)	NAME/LOGO	
12	1	1290654	PT8 (SILVER)	NAME/LOGO	
	1	1290655	PT9 (SILVER)	NAME/LOGO	
	1	1290680	PT6 (SILVER)	NAME/LOGO	

* N/A to PT6 Models

MACHINE DECALS – Identification



1. Part Number 09.811.04

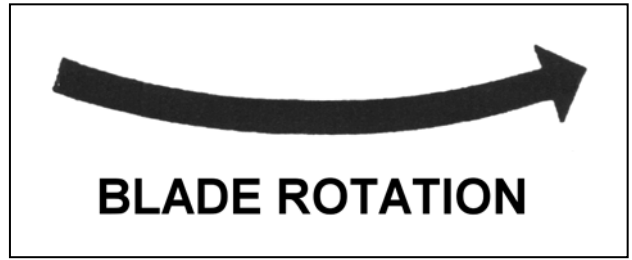

2. Part Number D137



4. Part Number D132

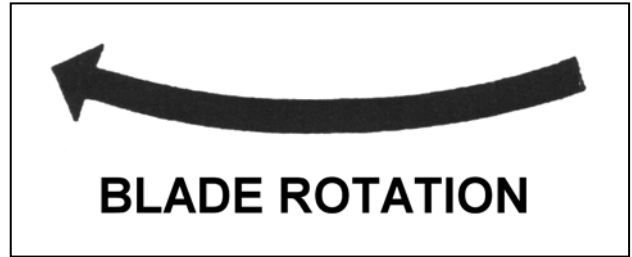

3. Part Number D138



5. Part Number 09.821.29



6. Part Number 09.821.30



8. Part Number 09.810.02



7. Part Number 09.821.34



9.



11. Part Number 1290649 (Silver)

PT6

PT8

PT9

12. Part Number 1290680 (Silver) Part Number 1290654 (Silver) Part Number 1290655 (Silver)

TRACTOR REQUIREMENTS

The PT8 & PT9 mowers will attach to most tractors with Cat. II & Cat. II Quick Hitch. The machines require a tractor with 540-RPM PTO and a minimum 40HP for PT8 models and 45HP for PT9 models. Adequate front-end weights should be fitted - *at least 20% of the tractor's weight must be on the front tyres when the mower is lifted to provide adequate traction for safe steering under good conditions.*

TRACTOR PREPARATION

BALLAST

WARNING Do not operate with less than 20% of the tractor's gross un-ballasted mass on the front wheels with the mower in the transport position.



WHEEL SPACING

The wheel spacing on the tractor should be increased when working on inclines or rough ground to reduce the possibility of tipping.

STABILISER BARS OR SWAY BLOCKS

Use stabiliser bars or sway blocks to prevent side sway of the mower.

DRAFT LINKS

The linkage to the lower draft links should be set in the 'float' position, allowing the unit to follow the contour of the terrain.

DRAWBAR

Shorten or remove the tractor drawbar so it will not interfere with the up and down movement of the mower.

WARNING Do not get, or allow others, between the tractor and the mower when the engine is running. Always 'kill' the engine, apply handbrake, engage tractor in gear, and pocket the key before attempting to work between tractor and machine.



TRACTOR ATTACHMENT

- Back the tractor up to the mower so that the lower draft arms are in alignment with the mower lower lift pins.
- Stop engine, lock the brakes or place the tractor in park.
- Connect the tractor and stabiliser bars to the lower lift pins.
- Adjust the top link so it will pin to the top holes in the A-frame.
- Attach webbing support strap at its mid-point through the A-frame shackle and attach ends to each rear corner shackle.

DRIVELINE ATTACHMENT

Before starting assembly of the driveline ensure that all paint, dirt and grease are removed from the gearbox shaft. To ease assembly apply a light coat of grease to splines prior to fitting.

WARNING

Do not assemble a driveline without a shield.

DRIVELINE LENGTH CHECK PROCEDURE

WARNING



A loose shaft could slip off and result in personal injury or damage to the mower. When attaching PTO yoke to tractor PTO shaft, it is important that the spring-activated locking collar slides freely and locking balls are seated in the groove on the PTO shaft.

WARNING



Before operating the mower, check to ensure the driveline will not 'bottom out' or become disengaged.

ALWAYS use Shear Bolts recommended by McConnel.

- Set parking brake, kill engine, remove and pocket the key.
- Disengage the driveline from the tractor PTO shaft.
- Slide the driveline together until it 'bottoms out' solidly.
- Apply coloured tape to the inner shield $\frac{1}{8}$ " (3mm) from the end of the outer shield (see diagram opposite).

Driveline in maximum compressed position

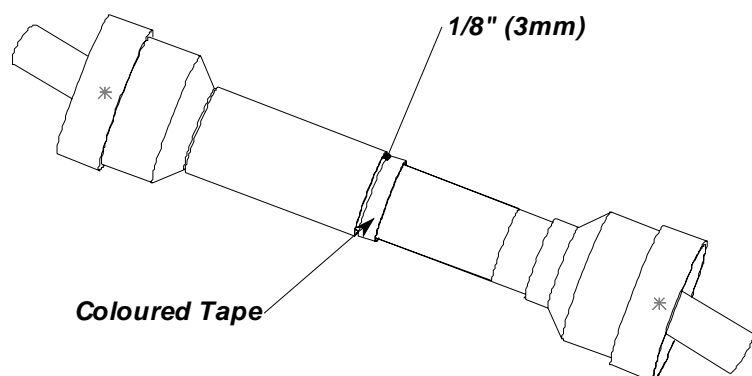

- Re-attach the driveline to the PTO shaft; ensuring balls are correctly seated in the groove on shaft.
- Raise mower to full transport height or until driveline just touches deck at front. If distance between coloured tape and outer shield is $1\frac{5}{8}$ " (40mm) or less, drive tubes should be shortened (see diagram below).
- Always maintain $1\frac{5}{8}$ " (40mm) clearance when operating in the shortest working position. Shorten inner and outer guard tubes equally. Shorten inner and outer sliding profiles by the same amount that the shield tubes were shortened. Round off all sharp edges and remove burrs. Grease sliding profiles (see diagram below).

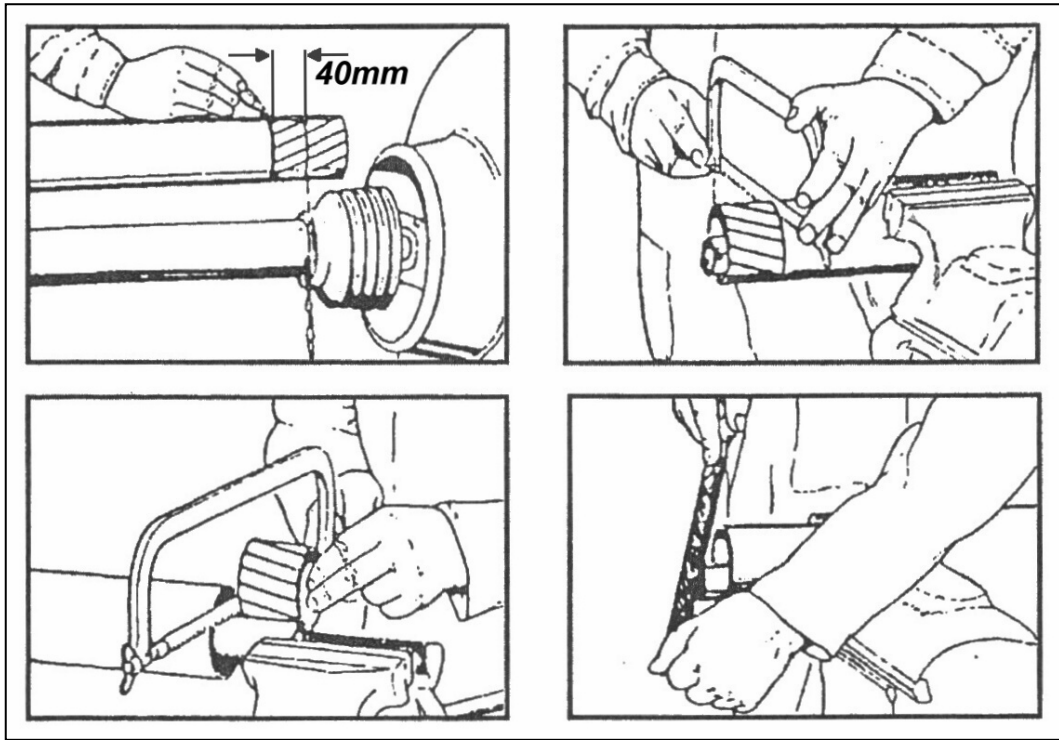

- Lower mower to lowest position possible. Check distance from coloured tape to end of outer shield tube. Driveline tube engagement must always exceed 12" (300mm). If not consult your dealer to obtain a longer driveline.

OPERATION

The safe operation of this machine is the responsibility of the operator who should be familiar with the machine, the tractor, and all safety practices associated with this type of mower, before attempting to start operation.

Before operating your rotary mower ensure it is properly lubricated and thoroughly inspected. The time and effort required to regularly lubricate and maintain the mower is minimal, but necessary, to provide long life and trouble free operation of your machine – *refer to maintenance section for details.*

These mowers are designed primarily for medium duty grassland topping, PT6 models are equipped with a single set of updraft blades mounted on a rotating blade carrier – the cutting direction of which is clockwise when viewed from below, whilst PT8 and PT9 models are equipped with two sets of updraft blades mounted on blade carriers rotating in opposing directions – the blade carriers are timed at 90° to each other – *see diagram below.*

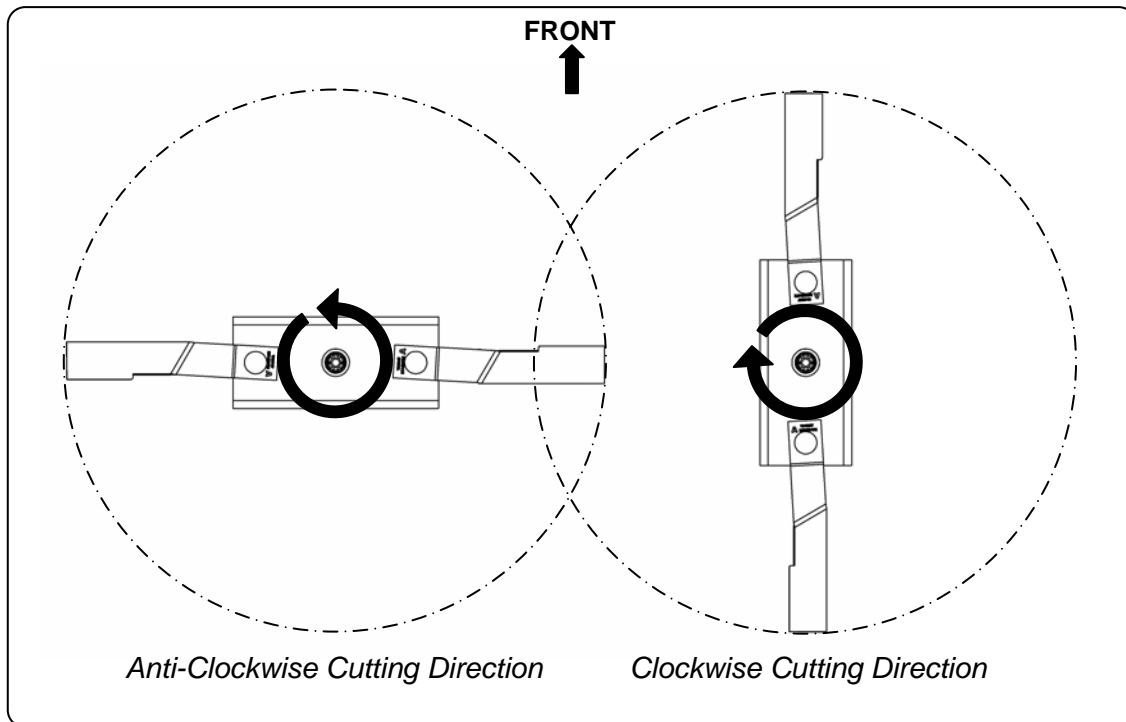

PT8 & PT9 Cutting Blades - Rotation & Timing Diagram (viewed from below).

CUTTING SPEED

Correct ground speed for cutting will depend upon the height, type and density of the material to be cut but normally will be in the range of 2–5 mph (3-8 km/h). Tall dense material should be cut at a low speed while thin medium height material can be cut at a faster ground speed – with practice the operator will be able to judge the conditions and materials to be cut and select the optimum forward speed to achieve efficient mowing.

Always operate the PTO at the recommended RPM when cutting – this is necessary to maintain the correct blade speed to produce a clean cut.

Under certain conditions tractor tyres may roll some grasses down and prevent them from being cut at the same height as the surrounding area. When this occurs, reduce the tractor ground speed, but maintain PTO rpm. The lower speed will permit grasses to, at least, partially rebound and be cut. Taking a partial cut and/or reversing the direction of travel may also produce a cleaner cut.

Always stop mowing when people are passing by and keep bystanders at a safe distance away from risk of danger.

CUTTING HEIGHT

The cutting height of the mower is determined by the position at which the side skids are mounted on the machine – height adjustment is made by selecting higher or lower pairs of holes in the skids through which to attach the mounting bolts.

It is advisable to increase topping height by an extra 25mm (1") to avoid 'grounding' of the machine when cutting on uneven terrain.

Each side skid is fixed into position with 4 nuts and bolts (2 front & 2 rear) and may be mounted at four different cutting heights from 17.7mm to 107.7mm.

The diagram below shows the skid height adjustment positions where 'A' is the minimum cutting height and 'D' is the maximum.

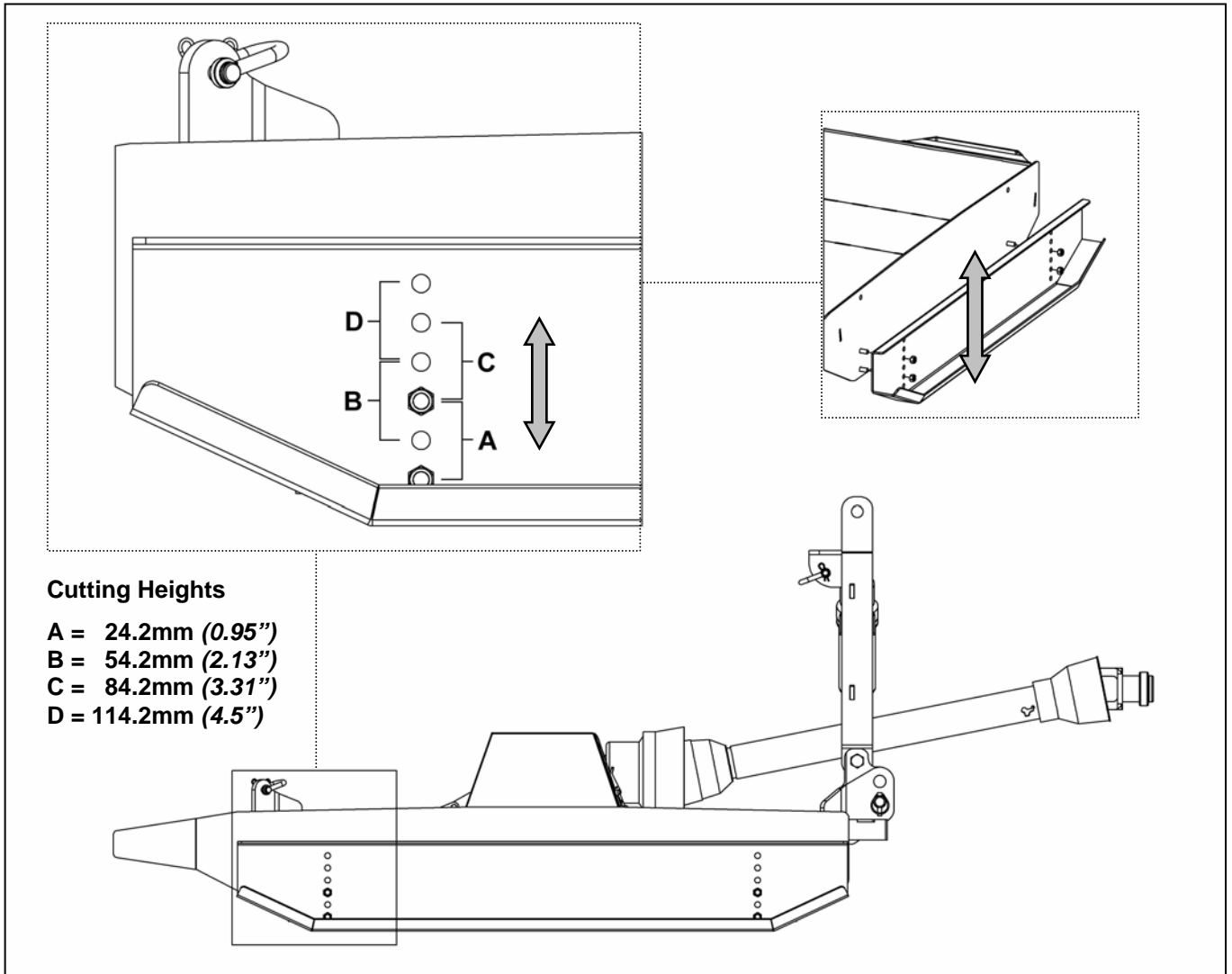

CUTTING HEIGHT ADJUSTMENT

WARNING: As adjustment to the cutting height requires initial removal of the skids it is vital that both machine and tractor are switched off, the unit parked on firm level ground and safely supported or 'blocked' before attempting this procedure – ensure when refitting the skids that matching sets of holes front and back and side to side are selected so that the mower remains parallel to the ground.

IMPORTANT: To avoid damage to the machine re-torque all bolts after the first 10 hours of initial operation – thereafter all bolts should be checked at regular intervals and re-tightened if required. The required torque setting for the blade carrier retaining nut on the gearbox lower shaft is 450 ft. lbs (610 Nm).

OFFSET MOWERS – TRANSPORTATION & WORK POSITIONS

For transportation the PT8 Offset Mower must be positioned directly behind and in line with the tractor, the machine is 'locked' in this position with a safety pin – the mower must always be transported in this position and the safety pin must always be fitted during transportation.

To move the mower from the transport position to the work position necessitates removal of the transportation safety pin followed by operation of the hydraulic ram to swing the mower round to the work position on the right-hand side of the tractor – the correct position for work is with the machine at right angles to the tractor.

Location of Transport Safety Pin on PT8 Offset Model

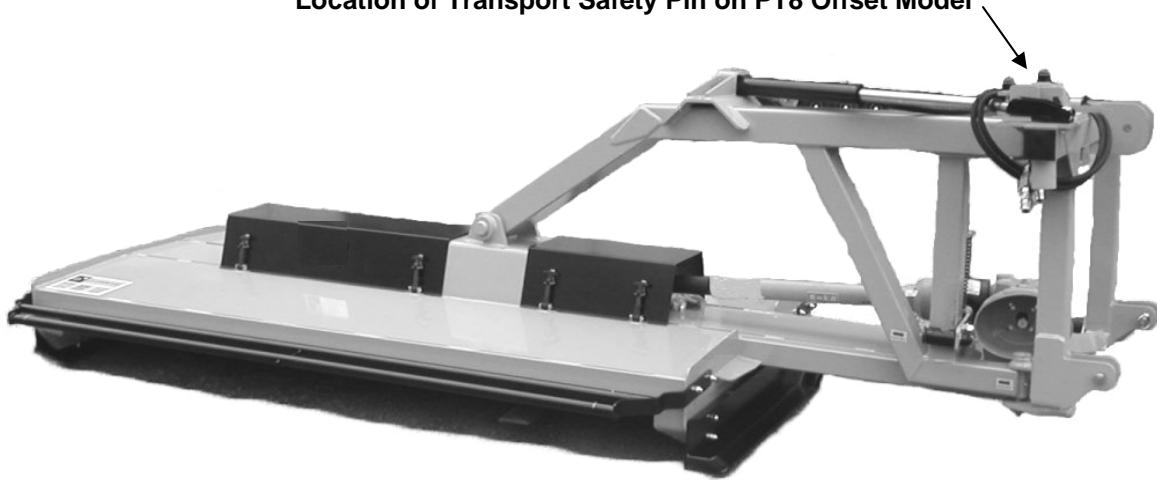

OFFSET MOWERS – Safety Breakaway System

Offset mowers have a built-in safety breakaway system to prevent damage should they encounter solid objects whilst working – this safety device is for unavoidable situations only and should be treated as such. Wherever possible the work area should be inspected before starting work and all immovable objects should be noted and avoided, do not use the breakaway system as a means of cutting around fixed objects – this is both dangerous and risks damaging the machine.

STARTING AND STOPPING THE MACHINE

Power for operating the Mower is supplied from tractor PTO. Refer to your Tractor Manual for instructions regarding engaging and disengaging of the PTO.

ALWAYS engage the PTO at low engine rpm and gradually build up the speed – sudden starts at high rpm can cause the Shear Bolt to shear.

ALWAYS operate at the recommended PTO speed.

LEARN how to stop the Tractor and Mower quickly and safely in case of emergency.

IMPORTANT: Stop the Mower and Tractor immediately upon striking an obstruction. Inspect the Mower for damage and repair before resuming operation. **DO NOT DISENGAGE PTO WHEN ENGINE IS AT FULL PTO RPM** – always idle engine before disengaging the PTO.

WARNING



Avoid personal injury. When attempting to stop a tractor that does not have live PTO, the momentum created by the blade carrier of a rotary mower can cause the tractor to be pushed forward. **DO NOT** operate this Mower unless tractor has live or independent PTO.

To commence operation, reduce engine speed and engage the tractor PTO. Before starting to cut, gradually increase the engine speed to develop full PTO speed.

Enter the area to be cut with the mower operating at PTO speed and, if it becomes necessary to temporarily regulate engine speed during operation, increase or decrease the throttle gradually.

WORKSITE CHECKS AND PROCEDURES

WARNING



To avoid risk of personal injury or damage to the machine it is good practice to inspect the work area prior to operation – take time to pick up rocks, bottles, wire etc. and any other hazardous debris you may find in order to avoid them coming into contact with the working machine. The blade tip speed of these machines is well in excess of 4000m/min and therefore has the potential to hit movable objects long distances at high speed.

WARNING



Note the position of non-removable hazards and dangers so that they can be avoided during operation.

Extremely tall grass should be cut twice. Raise the Mower and cut twice to the desired height. Cut the second time to the desired height at 90 degrees to the first pass.

Remember that sharp blades will produce a cleaner cut and will use less power.

Before cutting, analyze the area to determine the best cutting procedure. Consider the height and type of material as well as the terrain type – hilly, level, or rough.

DETACHMENT OF THE MACHINE

- Lower the Mower to the ground and park the Tractor with brakes on, kill the engine, remove and pocket the key.
- Wait until the PTO has stopped rotating before dismounting the Tractor.
- Disconnect the Driveline from the Tractor PTO.
- Disconnect the Top Link and the Lower Lift Links from the Mower.
- Always reinstall the Master Shield over the Tractor PTO shaft - this shield should always remain in place and should only be removed to enable the connection or disconnection of the Driveline.

Removal of the machine should always be performed on a firm level site.

STORAGE OF THE MACHINE

Inspect the machine prior to storage for any signs of wear or damage – repair or replace any parts that are worn or damaged in order that the machine is prepared and ready for work when next needed. Storage of the machine should ideally be in a clean dry environment safely sited where it is protected from the elements.

IMPORTANT:

This machine must only be used to perform tasks it was designed to do - never use this machine for anything other than its designated task or for tasks beyond its capability.

Warranty for breakdowns will not be allowed if the machine has been misused in any way – this includes: overloading by the operator, operating without due care, use of non-genuine parts, lack of daily and/or regular maintenance, failure to remove, observe, or avoid obstacles whilst working. This machine will not be covered by warranty if 'hired out' or operated by third parties.

MAINTENANCE

WARNING Always disengage the PTO before raising the Mower for transporting or making adjustments.



Do not allow excess grease to collect on or around the machines parts - particularly when operating in sandy areas.

LUBRICATION POINTS

The illustration below shows the location of the machines lubrication points and the frequency at which these points should be lubricated under normal working conditions – severe or unusual conditions may require more frequent lubrication. Use SAE multi-purpose, lithium type grease for all greasing locations indicated - ensure the fitting is thoroughly cleaned before applying lubricant to avoid contamination by dirt or grit.

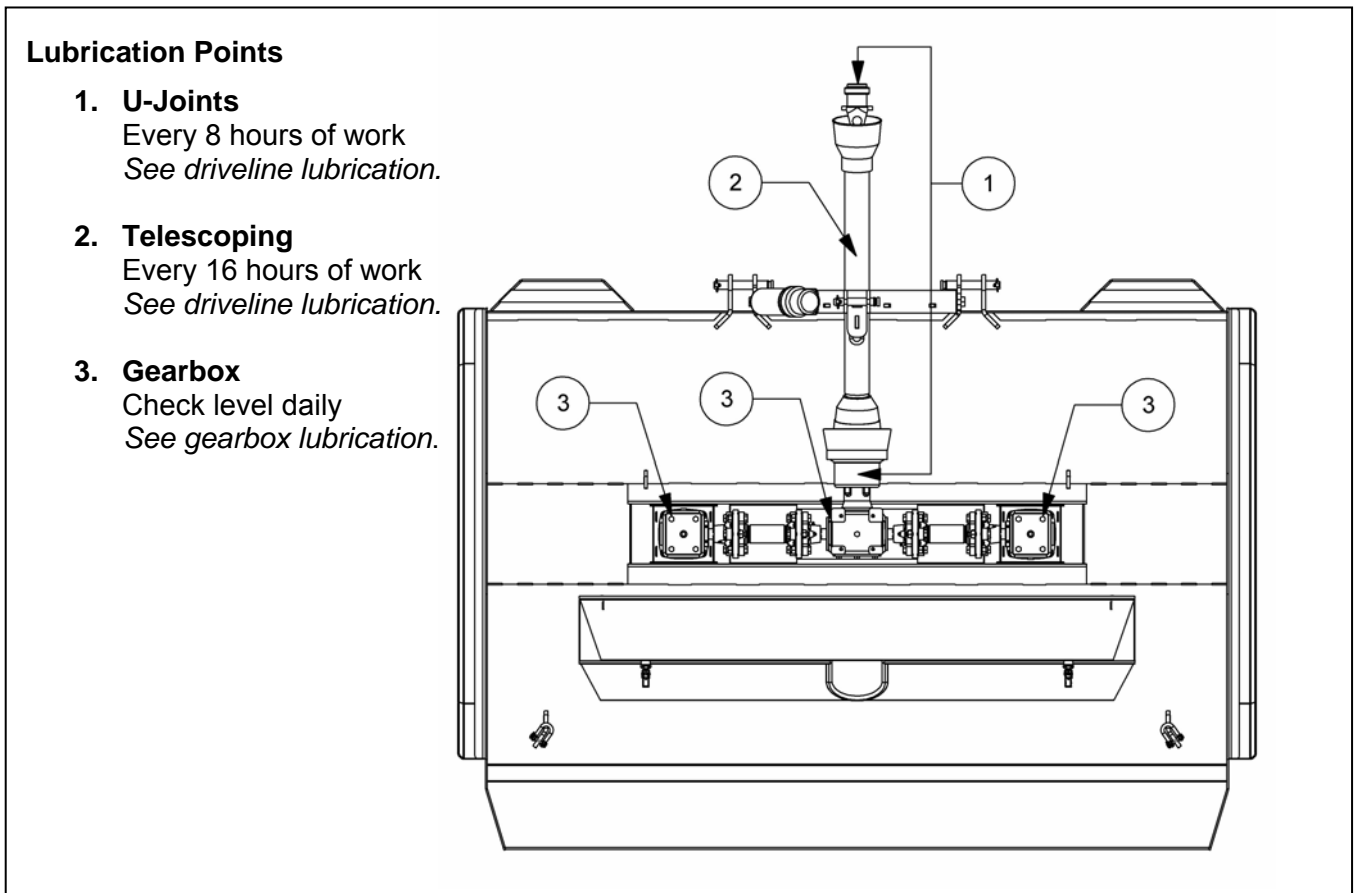

GEARBOX LUBRICATION

The gearbox will be filled with lubricant to the test plug level prior to shipment, however, as a precaution you should check the oil level at the test plug before operating the machine and frequently thereafter - *daily during normal use*.

The gearbox should not require additional lubricant unless the box is cracked or a seal is leaking. It is recommended that the oil level plug be removed every 8 to 10 hours of normal operation and oil added until it runs out of the Test Plug hole.

The test plug is located on the rear of the gearbox and the filler plug is located on the top of the gearbox.

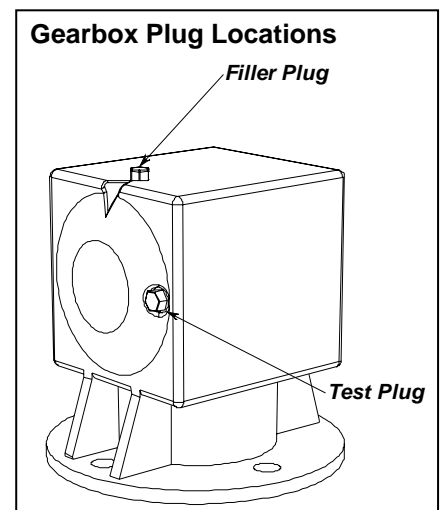

Recommended lubricants for the Gearbox are: Exxon – Spartan EP220, Mobil HD 80W90, or equivalent. Required lubricant is a SAE 90 or SAE 80W90 with EP additives for extreme pressure and temperature with a API-GI-5 Service rating.

NOTE: Overfilling the Gearbox will result in pressure build up and cause Oil Seals to leak.

ATTENTION: If Gearbox suddenly starts making an unusual noise, stop immediately, check for leaks, and refill Gearbox as required.

DRIVELINE LUBRICATION

Grease Fittings are located on the cross assembly of each U-Joint and on the telescoping tubes.

Grease the U-Joint after every 8 hours of use - *do not force grease through the needle cup assemblies.*

Grease the telescoping tubes after every 16 hours of use.

On some PTO to hitch connections, it may be necessary to cut a hole in the shields to facilitate alignment of the grease fittings for lubrication. Lubricate the shield bearings every 8 hours - see *diagram below.*

Refer also to Information sheet that was shipped attached to PTO shaft.

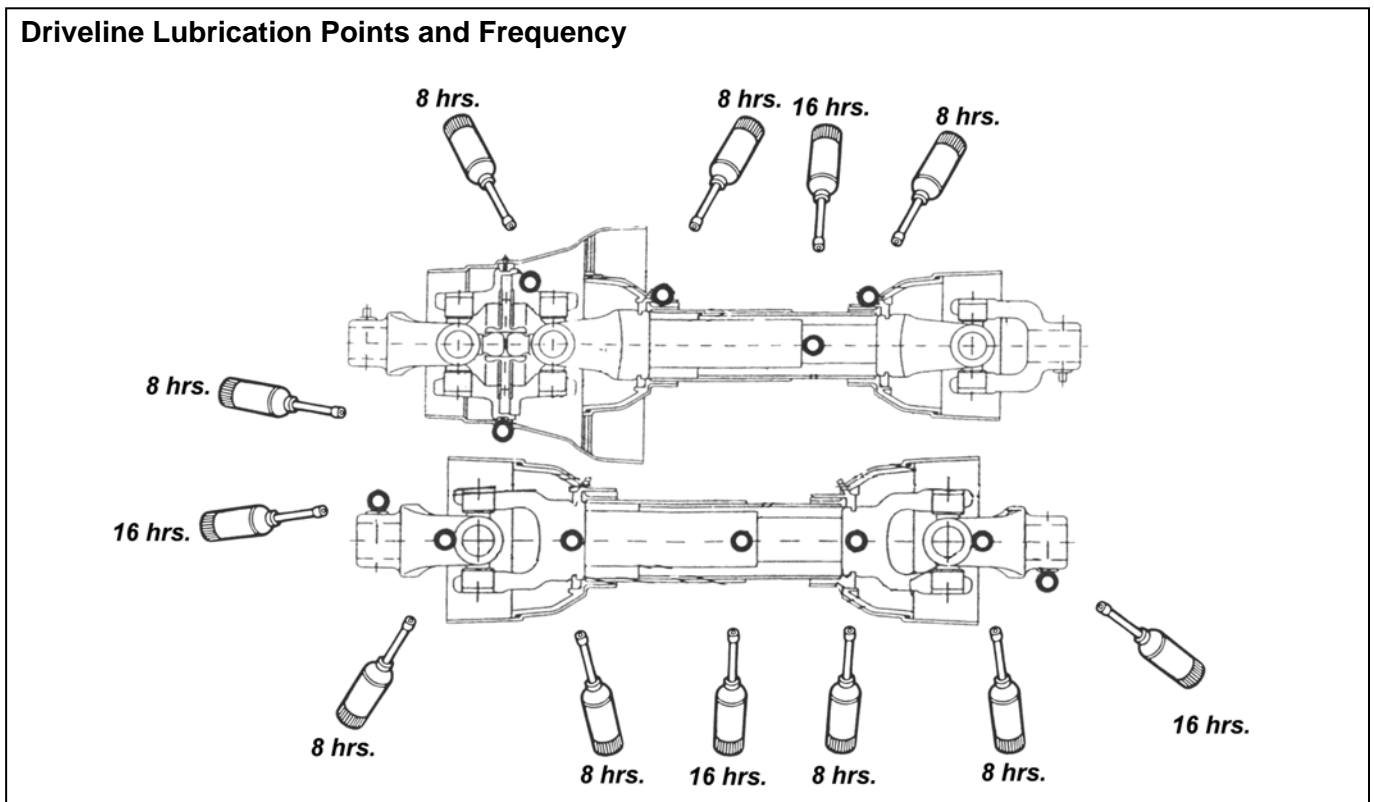

DRIVELINE SHIELD REMOVAL

The driveline integral shields should not become dented or otherwise damaged. The integral shield assembly has a nylon bearing at each end, which should turn freely, and will require lubricating after every 8 hours of use. To remove the integral shields for replacement or repair, turn the three nylon bolts through a ¼ turn in the shield slots of the cone and tube and remove them. Slip the shield cone assembly off the inner section of the driveline and install the new or repaired shield on the driveline. Place the split nylon bearing over the driveline housing against the yoke and in the bearing groove. Install shield over the housing so the nylon bearing fits into the shield bearing retainer. Align a slot in the shield cone with one of the slots in the shield. Put one of the nylon bolts back in through the aligned slot and turn until it is perpendicular to the slots. Replace the other two nylon bolts.

CAUTION

Ensure that the driveline integral shields are free to telescope and rotate around the driveline without binding.



WARNING

When attaching PTO yoke to tractor PTO shaft, it is important that the spring-activated locking collar slides freely and that the locking balls are seated in the groove on the PTO shaft. A loose shaft could slip off and result in personal injury or damage to your machine.



BLADE SERVICING

Blades should always be inspected prior to work each time you use the Mower to ensure they are in good working condition and correctly installed. Replace any Blade that is bent, excessively nicked, worn or otherwise damaged. Small nicks can be ground out when sharpening. If a Blade requires replacing, it is recommended that they be replaced in pairs in order to maintain balance.

IMPORTANT: When sharpening blades, grind each blade by the same amount to maintain balance. The difference in blade weights should not exceed 1 ounce (28gms). Unbalanced blades will cause excessive vibration, which can damage gearbox bearings. Vibration may also cause structural cracks in the Mower housing.

WARNING

Use only Original Equipment Blades on this Mower. They are made of special-heat treated alloy steel. Substitute Blades may not meet the specifications required for this Mower and may fail in a hazardous manner that could cause injury.



BLADE SHARPENING

Always sharpen both blades at the same time to maintain balance. Follow the original sharpening pattern (see diagram below) and always sharpen blades by grinding. DO NOT heat and 'pound out' edge or sharpen the blade to a razor edge, but leave a 1/16" (1.6mm) blunt edge. Do not sharpen the back side of the blade.

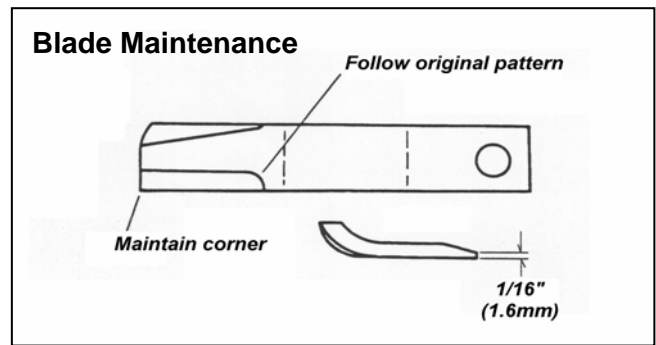

WARNING



Avoid personal injury. Always block the Mower up to prevent it from falling when servicing the blades and/or carrier.

BLADE REMOVAL

To remove blades for sharpening or replacement, remove the cover plate on the deck of the Mower near the gearbox and remove the lock nut from the blade bolt. NOTE: *Inspect lock nut after removal and replace if threads are damaged. Always replace lock nut when replacing blade bolt.*

When installing or replacing blades ALWAYS check the blade bolt pivot diameter for wear and replace if it is worn more than 1/4" (6mm) at any point. Install blade bolts with 'unworn' portion of blade bearing area towards centre of carrier. Tighten lock nut to 350 ft-lb. (475Nm).

WARNING



Avoid personal injury. Blade and/or Blade Carrier removal should be done only with the Tractor engine shut off, key removed, in neutral, parking brake on, with the PTO disengaged and the Mower blocked in the raised position.

BLADE CARRIER REMOVAL

Remove cotter pin and loosen slotted nut on gearbox shaft. Loosen but do not remove the nut until the blade carrier is loosened. Use a suitable 2-jaw 'gear puller' to pull the carrier off the tapered gearbox shaft. If gear puller is not available a long bar can be utilized by inserting it through blade bolt access hole with the end against rotor bar. Strike opposite end of bar with a sledgehammer. Rotate blade carrier through 180 degrees and repeat process.

BLADE CARRIER INSTALLATION

Clean the splines on both the blade carrier and output shaft. Position carrier on the gearbox output shaft and install special washer and nut.

Tighten nut holding blade carrier to minimum 450 ft-lb. (610Nm) strike the carrier near the hub several times with a heavy hammer to seat the hub. Use a suitable spacer over the nut to prevent damage to the nut and its thread. Retighten the nut to 450 ft-lb. (610Nm). Install cotter pin and spread its ends.

IMPORTANT: Always rechecks gearbox output shaft slotted blade carrier retaining nut torque after a few hours of operation.

WARNING



Avoid personal injury. Do not attempt to work under a Mower without suitable support blocks to keep the frame from falling.

TROUBLESHOOTING - General

PROBLEM	POSSIBLE CAUSE	REMEDY
NOT CUTTING CLEAN	<p>Blades dull.</p> <p>Blade rotation incorrect.</p> <p>Using straight blades.</p> <p>Carrier rpm too low.</p> <p>Mower not leveled.</p> <p>Tyres flattening grass.</p> <p>Ground speed too fast.</p> <p>Blades locked back.</p> <p>Blades riding up due to Blade Bolt wear.</p> <p>Blades bent up.</p>	<p>Sharpen or replace Blades.</p> <p>Use correct Blade carrier.</p> <p>Use Fan Blades in grass.</p> <p>Increase PTO to recommended rpm</p> <p>Adjust machine level.</p> <p>Increase tyre spread to 90" (2.25m).</p> <p>Reduce ground speed.</p> <p>Free Blades.</p> <p>Replace Blade Bolts.</p> <p>Replace Blades.</p>
BREAKING BLADE BOLTS	<p>Operating with loose Blade Bolts.</p> <p>Worn Blade Bolt.</p>	<p>Tighten Blade Bolts to 350 ft lb. (475 Nm) – <i>Right hand threads.</i></p> <p>Replace Bolt.</p>
CUTTING TOO HIGH	<p>Blades bent up.</p> <p>Blade Carrier bent.</p> <p>Blades on upside down.</p>	<p>Replace Blades.</p> <p>Straighten or replace Blade Carrier.</p> <p>Turn Blades right side up and tighten.</p>
MOWER VIBRATES	<p>Blade locked back.</p> <p>Drivelines not phased.</p> <p>Blade broken.</p> <p>Blade Carrier bent.</p> <p>Blade Hub not properly seated on Shaft.</p> <p>New Blade matched with worn Blade.</p>	<p>Loosen locked Blade.</p> <p>Replace Driveline.</p> <p>Replace Blades in sets.</p> <p>Repair or replace Carrier.</p> <p>Remove Hub, check for wear and replace or seat properly - <i>Tighten Hub Bolts to 450 ft lb. (610Nm).</i></p> <p>Replace Blades in sets.</p>
MOWER WINDROWING	<p>Cutting heavy material.</p>	<p>Raise Mower and reduce groundspeed.</p>
FAST BLADE WEAR	<p>Cutting in sandy or rocky conditions.</p> <p>Blades too soft.</p>	<p>Increase cutting height.</p> <p>Replace Blades; with hardened high-quality Blades from the manufacturer.</p>
BLADE BOLTS WORKING LOOSE	<p>Bolts not tightened.</p> <p>Bolt hole elongated or oversized.</p> <p>Locknut worn out.</p>	<p>Tighten Bolts to 350 ft lb. (475 Nm.)</p> <p>Replace Blade Carrier.</p> <p>Replace Locknut.</p>

TROUBLESHOOTING – PTO Shafts

PROBLEM	POSSIBLE CAUSE	REMEDY
BROKEN CROSS OR CUPS	Load too high for joint.	Use protective device with joint. Check joint angles and phasing. Slow down or raise Mower.
END GALLING OF CROSS AND CUPS	Speed too high during turns.	Reduce PTO speed.
NEEDLE ROLLERS HAVE BRINELLED INTO CUP AND CROSS	Load too high for joint.	Check for small joint angles. Check joint angles and phasing.
SHAFT OR TUBE TWISTED	Over-loaded.	Replace part and then slow down or raise Mower. Use protective device.
TUBE BROKEN IN WELDED SEAM	Over-loaded.	Replace part.
YOKE BROKEN AT EAR TIP	Over-loaded.	Replace part.
DRIVELINE INTEGRAL SHIELDS RATTLING OR NOT TURNING FREELY	Integral Shields deformed. Nylon Bearing worn.	Replace Shield. Replace Nylon Bearing.

TROUBLESHOOTING – Gearboxes

PROBLEM	POSSIBLE CAUSE	REMEDY
NOISY GEARBOX	Improper backlash. Rough Gears. Worn Bearings	Refer to your Dealer. Run in or change Gears. Replace Bearings.
OIL BLOWING OUT VENT PLUG	Flat bottomed Vent Plug or shallow cavity Plug. Oil level too high.	Replace with proper Vent Plug, cavity in Oil Plug should be approximately $\frac{5}{8}$ " (16mm). Lower Oil level to Plug.
GEARBOX LEAKING	Damaged Oil Seal. No Oil Seal. Oil too light. Bent Shaft. Oil Seal race rough. Oil Seal installed incorrectly. Oil Seal not sealing in housing. Bearings loose. Vent Plug stopped up. Oil level too high. Gasket damaged. Bolts loose.	Replace Seal. Install Oil Seal. Use EP90. Replace Oil Seal and Shaft. Replace Shaft or repair race. Replace Seal. Replace Seal or use sealant. Adjust Bearings. Open Vent Plug. Drain Oil to correct level. Replace Gasket. Tighten Bolts.

**PT6, PT8 & PT9
PASTURE TOPPERS
- Parts List -**

MAIN FRAME – PT6

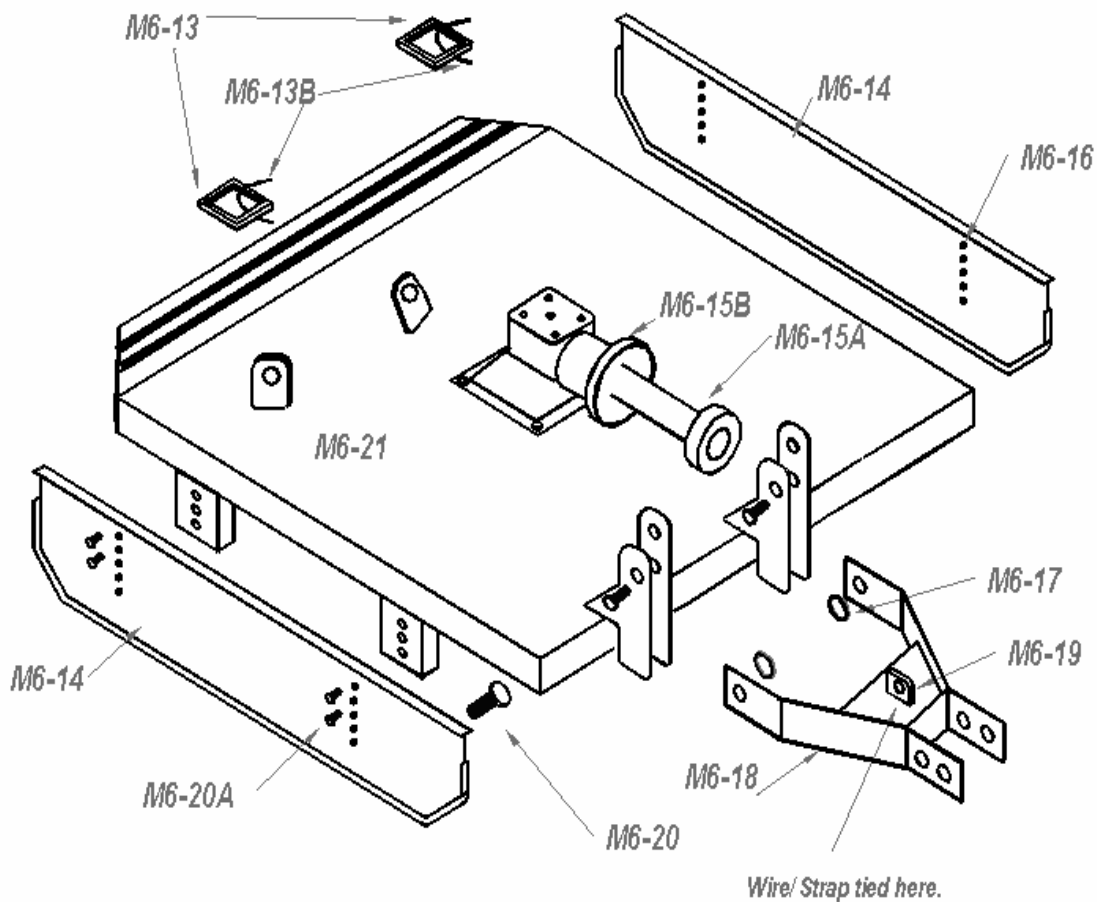

REF.	QTY.	PART No.	DESCRIPTION
M6-13	3	1096254	D/ BOW SHACKLE
M6-13B	2	1096266	2 TONNE STRAP
M6-14	2	1096267	ADJUSTABLE SLIDES (SKIDS)
M6-15A	1	1096275	PTO SHAFT – T40
M6-15B	1	21238.01	CONE COVER 190-000-536
M6-16	8	9143006	NYLOC NUT
M6-17	2	9143007	LOCK NUT
M6-18	1	1096268	A- FRAME
M6-19	1	1096269	STRAP CARRIER
M6-20	8	9213066	BOLT
M6-20A	8	9100106	FLAT WASHER
M6-21	1	1096270	MAINFRAME

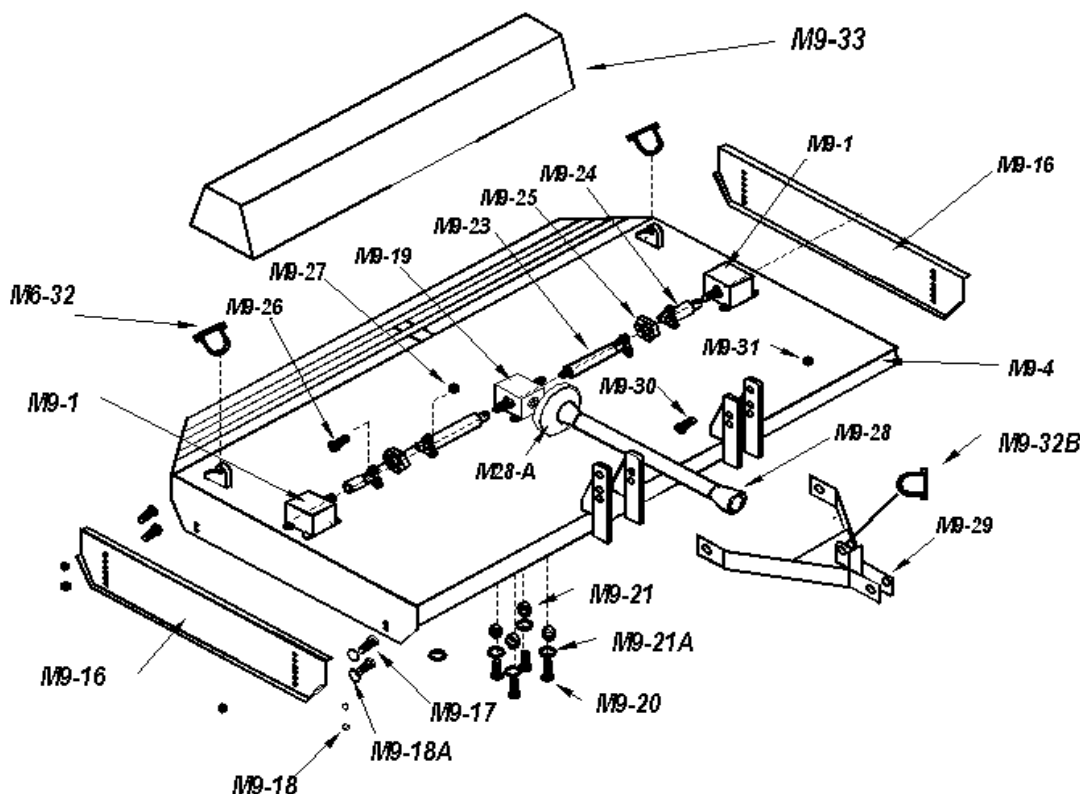

REF.	QTY	PART No.	DESCRIPTION
M9-4	1	1096250	Main Body PT8
M9-4	1	1096251	Main Body PT9
M9-16	2	1096252	Adjustable Slides
M9-17	8	9313066	Bolt
M9-18	8	9143006	Lock Nut
M9-18A	12	9100106	Flat Washers
M9-19	1	21459.01	Gearbox – 267 – 006
M9-20	4	9313066	Bolts
M9-21	4	9100206	Spring Washer
M9-21A	4	9100106	Flat Washer
M9-23	2	21457.04	Main Drive Shaft PT8
M9-23	2	21457.02	Main Drive Shaft PT9
M9-24	2	-	End Drive Shaft
M9-25	2	-	Rubber Coupling
M9-26	12	9213166	Bolts
M9-27	12	9143006	Lock Nut
M9-28	1	21040.03	PTO Shaft with Overrun & Shearbolt
	1	9200051	Shearbolt
M9-28A	1	21238.01	Cone Cover –190-000-536
M9-29	1	1096253	A Frame
M9-30	2	9313118	Bolt
M9-31	2	9100108	Lock Nut
M9-32	3	ELA0027	D Shackle
M9-32B	1	1096254	D16/D Bow Shackles – S4179
M9-33	1	1096255	Safety Guard

MAIN FRAME – PT8 Offset

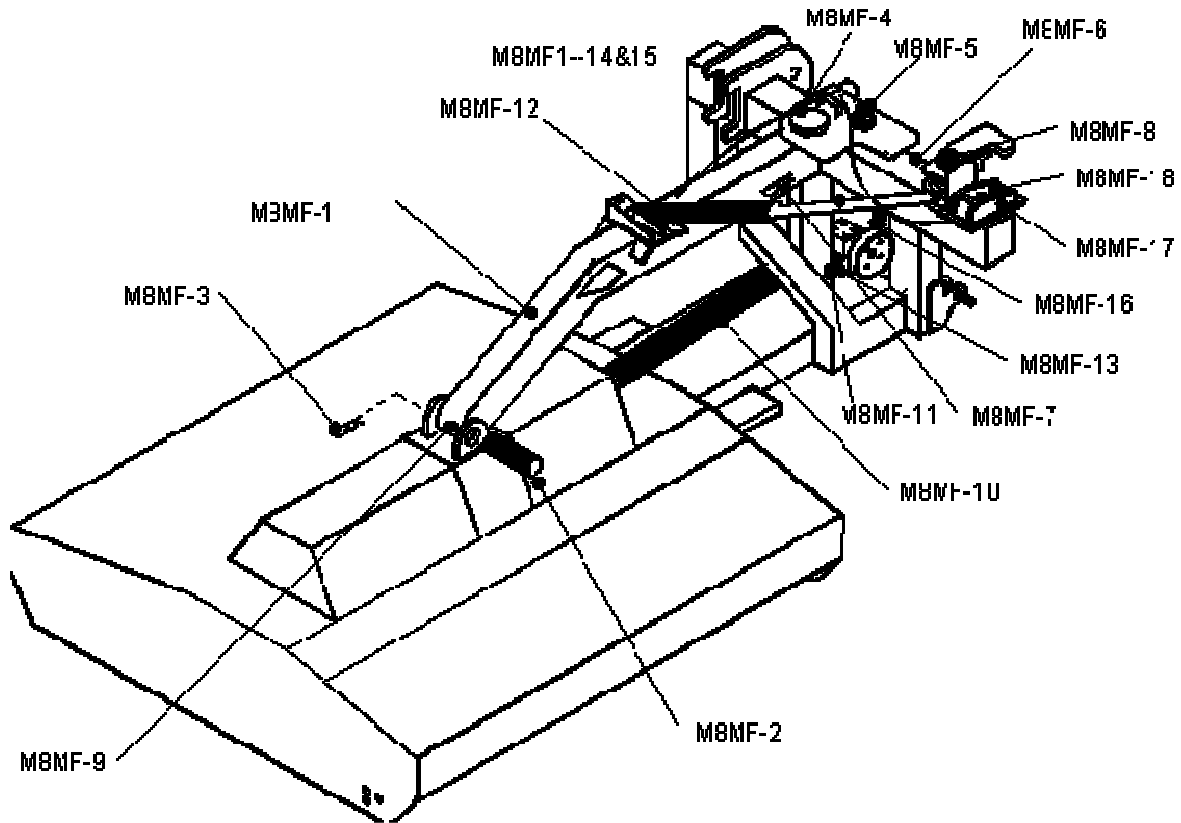

REF.	QTY	PART No.	DESCRIPTION
M8MF-1	1	1096288	Carrier Arms
M8MF-2	1	1096289	Carrier pin
M8MF-3	4	1096290	Split Pin
M8MF-4	4	1096291	Link Frame Pin
M8MF-5	2	1096292	Safety Lock Pin
M8MF-6	16	1096293	Linkage Frame
M8MF-7	16		R Clip
M8MF-8	1	9143008	Nyloc Nut
M8MF-9	1		Greaser
M8MF-10	1		PTO Shaft
M8MF-11	1	1096294	Lower Frame Pin
M8MF-12	1	1096295	Hydraulic Ram
M8MF-13	1		Greaser
M8MF-14	2	1096297	Roller Bolt
M8MF-15	2	1096297	Roller
M8MF-16	1	1096298	Spring
M8MF-17	1	9313107	Bolt
M8MF-18	1	0100106	Flat Washer

CHASSIS – PT8 Offset

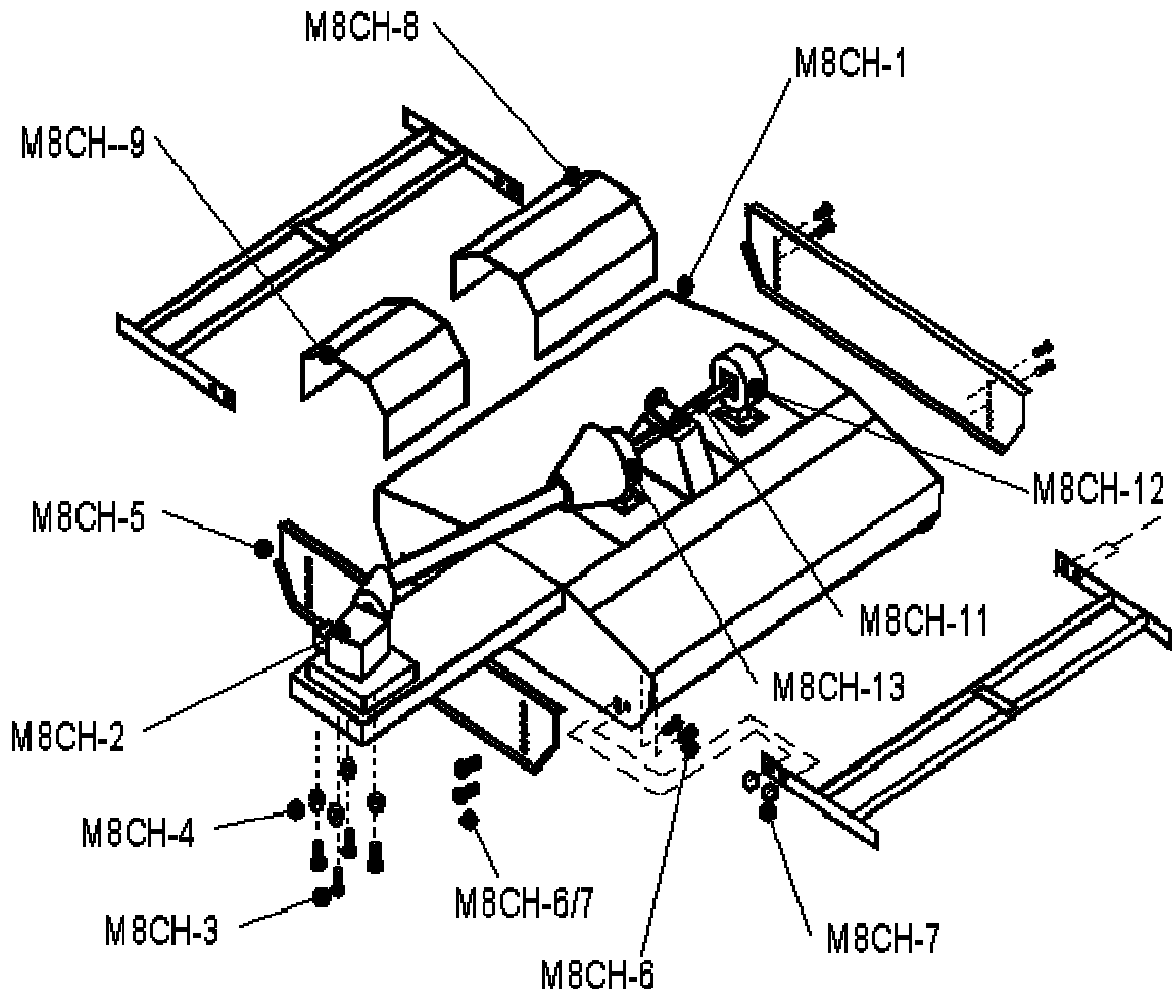

REF.	QTY	PART No.	DESCRIPTION
M8CH-1	1	1096271	Main Frame
M8CH-2	1	1096272	Gearbox
M8CH-3	4	9317056	Bolt
M8CH-4	4	9100106	Washer
M8CH-5	2	1096279	Adjustable Slides
M8CH-6	16	9213066	Bolt
M8CH-7	16	9143006	Nyloc Nuts
M8CH-8	1	1096273	Back Guard
M8CH-9	1	1069274	Front Guard
M8CH-10	1	1096275	PTO Shaft
M8CH-11	1	1096276	Transfer Shaft
M8CH-12	1	1096277	Gearbox
M8CH-13	1	1096278	T-Box

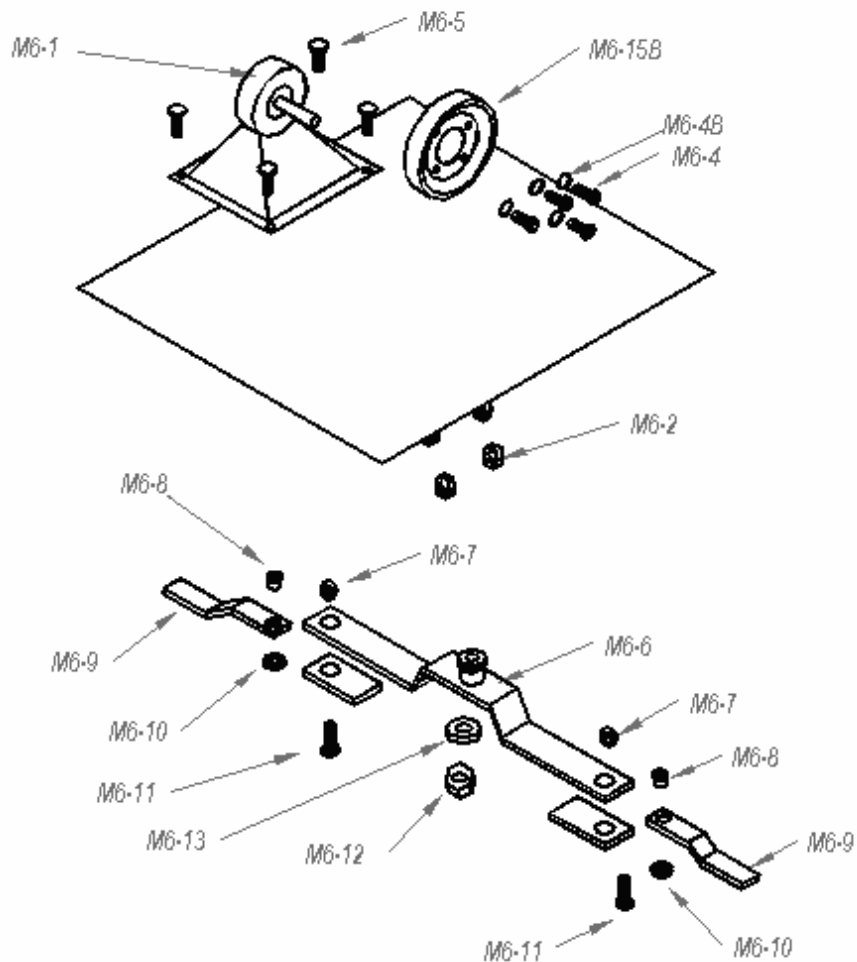

REF.	QTY.	PART No.	DESCRIPTION
M6-1	1	1096300	GEARBOX 205-801
M6-2	4	9143007	NYLOC NUT
M6-4	4	1096301	BOLT
M6-4B	4	9100104	FLAT WASHER
M6-15B	1	21238.01	CONE COVER 190-000-536
M6-5	4	9213107	BOLT
M6-6	1	1096302	BLADE CARRIER
M6-7	2	9143008	NYLOC NUT
M6-8	2	1096303	UPPER BLADE BUSHING
M6-9	2	1096304	DOUBLE SIDED BLADE
M6-10	2	1096305	LOWER BLADE BUSHING
M6-11	2	1096306	BOLT
M6-12	2	1096307	CASTLELLATED NUT & SPLIT PIN
M6-13	1	1096308	FLAT WASHER
M6-22 (circled)	1	1096309	BLADE BUSH SET (incl. Bushing & Bolts)

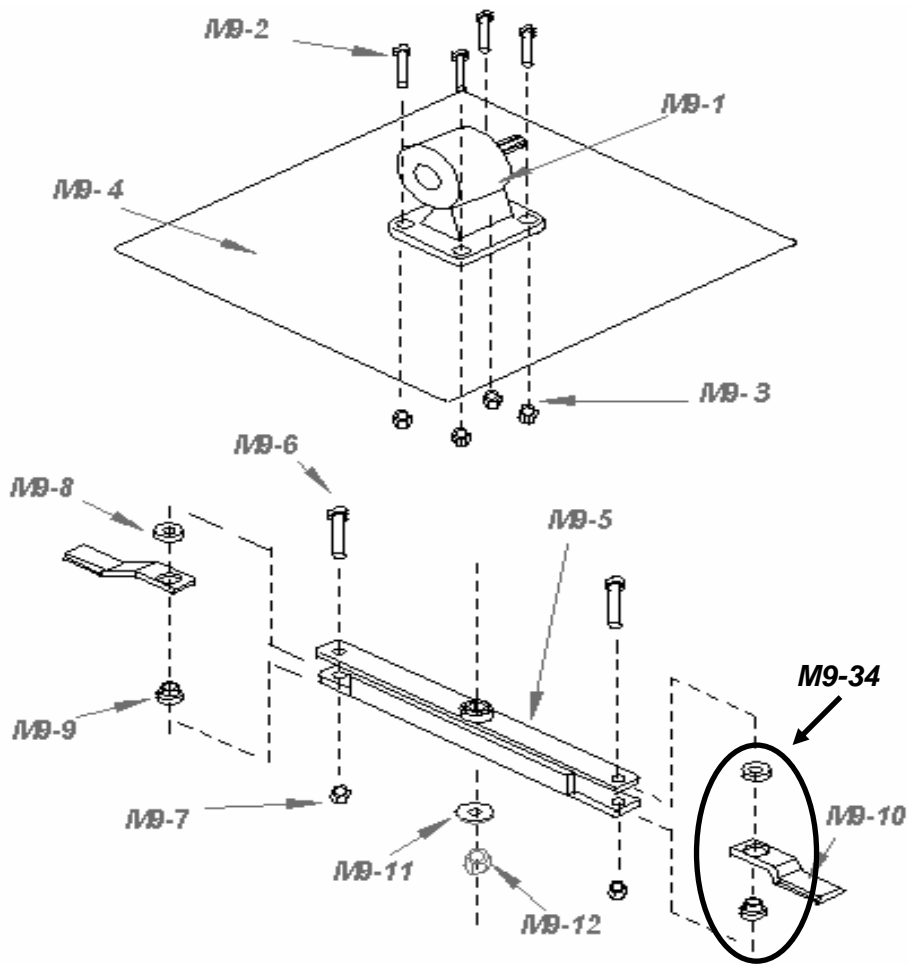

REF.	QTY	PART No.	DESCRIPTION
M9-1	2	21459.02	Gearbox 805-205
M9-2	4	9313107	Bolt
M9-3	4	9143007	Lock Nut
M9-4	1	1096256	Main Body PT8
M9-4	1	1096257	Main Body PT9
M9-5	1	1096265	Blade Carrier PT8
M9-5	1	1096258	Blade Carrier PT9
M9-6	2	9213168	Bolt
M9-7	2	9143008	Lock Nut
M9-8	2	1096259	Upper Blade Bushing
M9-9	2	1096260	Lower Blade Bushing
M9-10	2	1096261	Cutting Blade
M9-11	1	1096262	Flat Washer
M9-12	1	1096263	Castellated Nut & Split Pin
M9-34 (circled)	1	1096264	Blade & Bushing Set

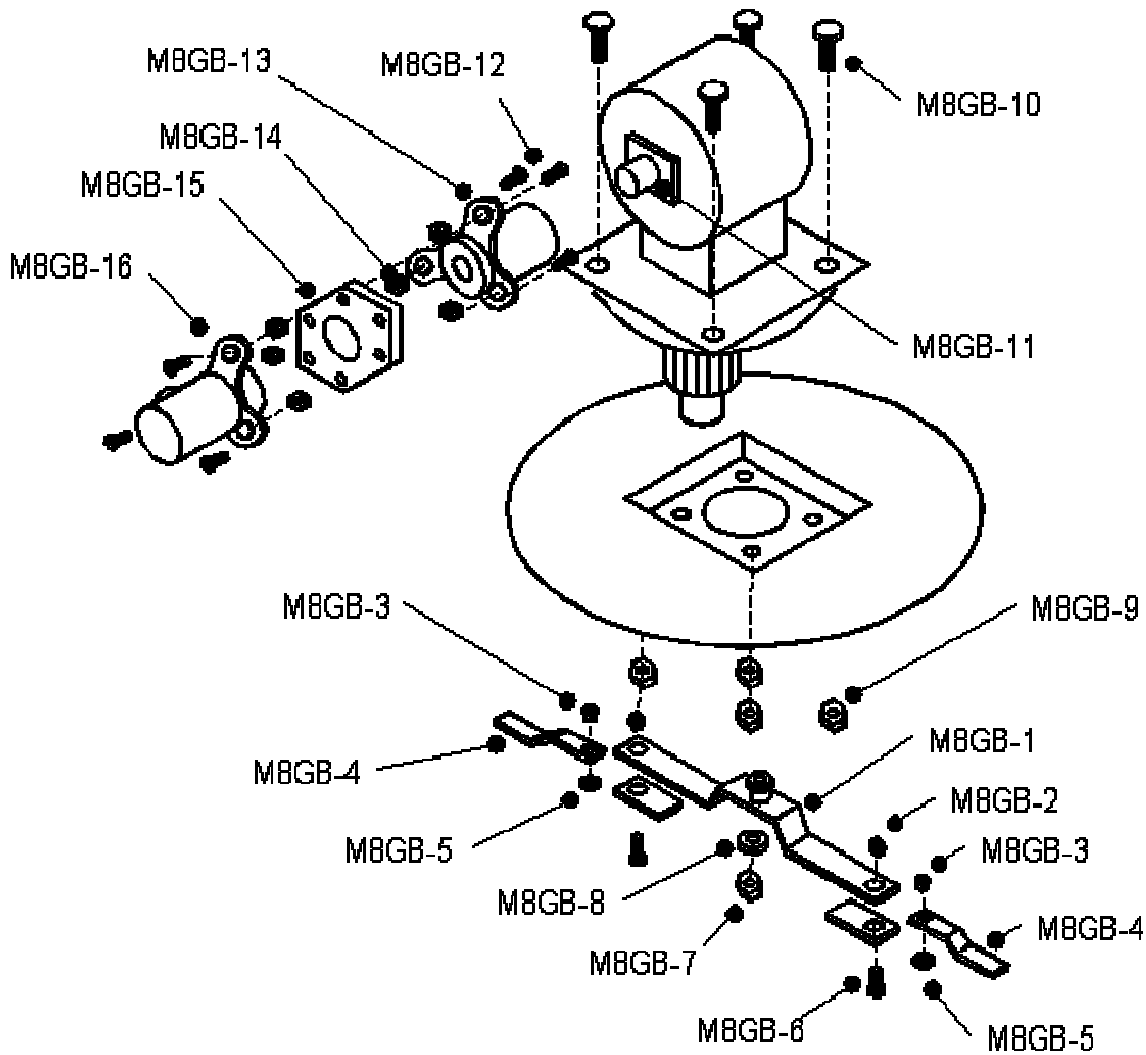

REF.	QTY	PART No.	DESCRIPTION
M8CH-1	2	1096280	Blade Carrier
M8CH-2	4	9143008	Lock Nut
M8CH-3	4	1096281	Upper Blade Bushing
M8CH-4	4	1096282	Double Edged Blade Bushing
M8CH-5	4	1096283	Lower Blade Bushing
M8CH-6	4	9217208	Bolt
M8CH-7	2	1096284	Nyloc Nut
M8CH-8	2	1096285	Washer
M8CH-9	4	9143007	Nyloc Nut
M8CH-10	4	9313087	Bolt
M8CH-11	1	1096277	Gearbox
M8CH-12	6	9213156	Bolt
M8CH-13	1	1096286	Driving Flange
M8CH-14	6	9113006	Nut
M8CH-15	1	1096287	Rubber Buffer
M8CH-16	1	1096276	Transfer Shaft

PT8 / PT9 Standard Models Illustrated

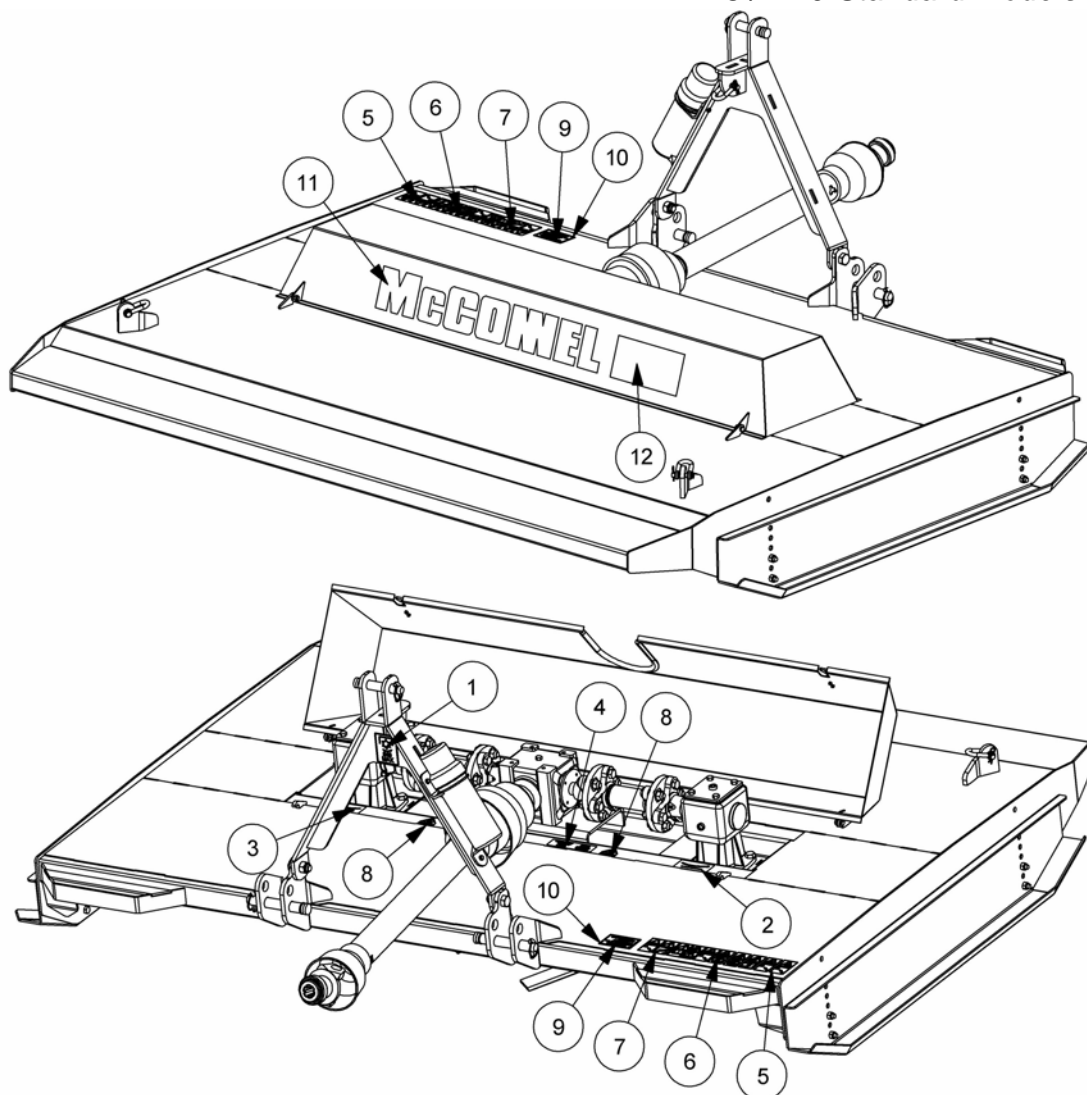

1096710K DECAL KIT - PT6 Models
1096705 DECAL KIT - PT8 Models
1096706 DECAL KIT - PT9 Models

1	1	09.811.04	DECAL - 540 RPM PTO SPEED
2	*	D137	DECAL - CCW BLADE ROTATION
3	*	D138	DECAL - CW BLADE ROTATION
4	*	D132	DECAL - BLADE TIMING
5	1	09.821.29	DECAL - COMBINED EURODECAL
6	1	09.821.30	DECAL - COMBINED EURODECAL
7	1	09.821.34	DECAL - COMBINED EURODECAL
8	*	09.810.02	DECAL - GREASE (40 HOURS)
9	1	1335246	DECAL - SERIAL No. PLATE
10	4	7103230	DECAL - POP RIVET
11	1	1290649	DECAL - McCONNEL (SILVER)
12	1	1290654	DECAL - PT8 (SILVER)
	1	1290655	DECAL - PT9 (SILVER)
	1	1290680	DECAL - PT6 (SILVER)

* N/A to PT6 Models



McConnel Limited, Temeside Works, Ludlow, Shropshire SY8 1JL. England.
Telephone: 01584 873131. Facsimile: 01584 876463. www.mcconnel.com