

PT240 Model

- A) Machine Body/Deck
- B) Gearbox
- C) Skid
- D) Beam
- E) Top Covers *(Shown removed to display drive components)*
- F) PTO Shaft
- G) Driveshafts & Couplings
- H) Headstock / Linkage Frame
- I) Transport Latch
- J) Ram

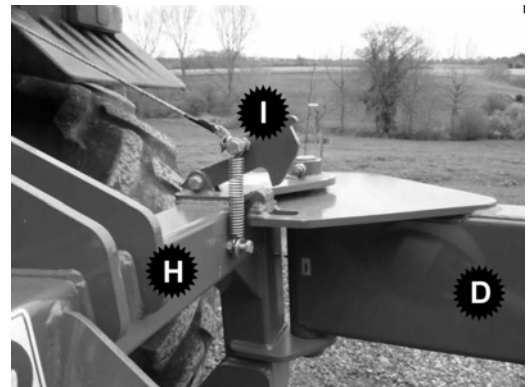

Blade Unit Components ▶

- A) Rotor Hub
 - B) Blade Carrier
 - C) Blades
- PT270 model shown*

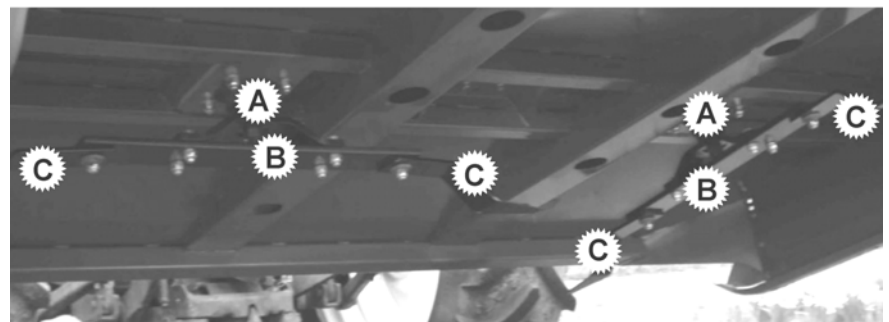

FEATURES

PT180 Model

- Working width of 1.80m
- Three position bolt on headstock
- Inline or semi-offset cutting positions
- Deep cranked free swinging blades
- 540-RPM PTO Shaft drive
- Shear bolt protection
- Over-run protection on PTO
- Single rotor
- Side skids
- Easily adjustable cutting height
- Lower link floatation

PT240 Model

- Working width of 2.40m
- Three-point Linkage Mounted
- Fully offset cutting position
- Hydraulic breakback safety system
- Deep cranked free swinging blades
- 540-RPM PTO Shaft drive
- Shear bolt protection
- Over-run protection on PTO
- Twin rotor
- Side skids
- Easily adjustable cutting height
- Floatation system

PT270 Model

- Working width of 2.75m
- Easy hitch lift arm brackets
- Inline cutting positions
- Deep cranked free swinging blades
- 540-RPM PTO Shaft drive
- Shear bolt protection
- Over-run protection on PTO
- Twin rotor
- Side skids
- Easily adjustable cutting height
- Lower link floatation

SPECIFICATIONS

Description	PT180 Model	PT240 Model	PT270 Model
Maximum Cutting Width	1.8m (5'11")	2.4m (7'11")	2.75m (9')
Minimum Power Requirement	30HP (22kW)	45HP (33kW)	45HP (33kW)
Machine Weight	500kg	565kg	565kg
Attachment Type	3-point Linkage	3-point Linkage	3-point Linkage
Cutting Height	24 – 114mm	24 – 114mm	24 – 114mm
Cutting Capacity (Max. Diameter)	30mm	30mm	30mm
Overall Machine Width	2.0m (6'7")	2.6m (8'6")	2.94m (9'8")
PTO Speed	540RPM	540RPM	540RPM
Protection	Shear Bolt	Shear Bolt	Shear Bolt
Offset Capability	Yes (Semi)	Yes (Fully)	No
Number of Rotors	1	2	2
Number of Blade Carriers	1	2	2
Number of Blades	2	4	4
Blade Tip Speed	4500m/min	4620m/min	4620m/min
Blade Overlap	N/A	50mm	50mm
Number of Skids	2	2	2
<i>Note: All weights, dimensions and power requirements are approximate and are for guidance purposes only.</i>			

SAFETY

There are obvious and potential hazards in the operation of this mower. The blades of this mower can propel objects for a great distance at very high speeds. Serious injury or even death may occur unless care is taken to ensure the safety of the operator, bystanders or passersby in the area.

KEEP CLEAR

Before attempting to operate this machine the owner and the operator should read, understand and heed the following information. Serious injury or death may occur if the safety advice given here is ignored. In addition to this safety advice, good 'common sense' will go a long way towards avoiding hazardous situations and reduce the risk of danger.

DANGER



Rotary mowers are capable under adverse conditions of throwing objects great distances (100 yards or more) and causing serious injury or death.

STOP MOWING IF PASSERSBY ARE WITHIN 100 YARDS (91 metres) unless:

- Front and rear deflectors, chain guards or bands are fitted and are in good workable condition.
- Mower sections or wings are running close to, and parallel to, the ground without exposed blades.
- Passersby are outside the existing thrown-object zone.
- All areas have been thoroughly inspected and foreign materials such as rocks, cans, glass and general 'risk' debris have been removed.

NOTE: Where grass and weeds are high enough to obscure debris that could be struck by the blades, the area should be inspected and debris removed, mowed at an intermediate height, and re-inspected closely to remove any remaining debris and mowed again at the desired final height. *(In addition to the safety aspect of this procedure it will also reduce wear and tear on the mower drive-train, spread cut materials better, eliminate 'streaking' and make the final cut more uniform).*

DANGER



All guards, bands, deflectors, driveline shields and gearbox shields should be used and maintained in good working condition at all times. They should be carefully inspected daily for missing or broken cable, chain links, shields or guards. Missing, broken or worn items must be replaced before attempting to use the machine to reduce the possibility of injury from thrown objects or entanglement.

WARNING



Extreme care should be taken when operating near loose objects such as gravel, rocks, wire and other debris. Foreign objects should be removed from the work site or avoided to prevent machine damage and/or bodily injury or even death.

DANGER



The rotating parts of this machine have been designed and tested for rugged use. However, they could fail upon impact with heavy solid objects such as steel guardrails and concrete abutments. Such impact could cause the broken objects to be thrown outward at very high velocities. To reduce the possibility of property damage, serious injuries, or even death, never allow the cutting blades to contact such objects.

WARNING The operator and all support personnel should wear 'hard hats', 'safety shoes' and 'safety glasses' at all times for protection from injury by falling objects and items thrown by the machine.



DANGER Operate the mower only with a tractor equipped with an approved 'roll over protection system (ROPS). Always wear your seat belt. Serious injury or even death could result from falling off the tractor – particularly during a turnover when the operator could be pinned under the ROPS or the tractor.



WARNING Before leaving the tractor seat always engage the brake and/or set the tractor transmission in parking gear. Disengage the PTO, stop the engine, remove the key and wait for all moving parts to stop. Place the tractor shift lever into a low range or parking gear to prevent the tractor from rolling. Never mount or dismount a moving tractor. Operate the tractor controls from the tractor seat only.



WARNING Many varied objects such as wire, cable, rope or chains can become entangled in the operating parts of mower head. These items could then swing outside the housing at greater velocities than the blades. Such a situation is extremely hazardous. Inspect the cutting area for any such objects and remove prior to mowing. Never allow the cutting blades to contact such items.



DANGER Be particularly careful in transport. Turn curves or go up hills only at a low speed and at a gradual steering angle. Ensure that at least 20% of the tractor's weight is on the front wheels to maintain safe steering. Slow down on rough or uneven surfaces.



WARNING Ensure that all necessary signs are correctly displayed, and clearly visible, when working or transporting on or near a public highway. (*Contact your Local Highway Authority to ensure you are fully conversant with your responsibilities on this subject*). Use flashing warning lights when working or transporting on or near a public highway to indicate to other road users a potential hazard. Always abide by local traffic regulations.



WARNING Ensure all moving parts of the machine are regularly inspected for wear and replaced with authorised service parts if an excessive amount of wear is present. Always use shear bolts recommended by McConnel.



WARNING Ensure the machine is regularly inspected for loose fasteners, worn or broken parts and loose or leaky fittings. Ensure all pins are fitted with cotter pins and washers. Serious injury can result from failure to maintain this machine in good working order.



DANGER Never leave the machine in the raised transport position – the machine could fall inadvertently and cause injury or death to anyone who might be under the machine.



DANGER Never clean or adjust PTO driven equipment with the tractor engine running. Kill the engine and pocket the key before attempting any maintenance on the machine.



DANGER Never allow riders on either the tractor or the mower - falling off can kill.



DANGER Never allow children to operate, ride on, or come close to the mower or the tractor.



DANGER Never work under the mower deck, framework or any raised component unless the mower has been securely supported and blocked using suitable substantial items to prevent sudden or inadvertent falling which could cause serious injury or even death.



WARNING Never operate the tractor and mower until you have read, and fully understood, the operation manual and are conversant with all the safety instructions stated here. Ensure you read all safety messages found on both the tractor and the mower.



WARNING Ensure you maintain all safety decals in good readable condition. If a decal should for any reason become illegible order a replacement immediately before permitting the machine to be used.



DANGER Never run a tractor engine in a closed building without adequate ventilation. The exhaust fumes can be hazardous to your health.



DANGER Ensure that a PTO shield is installed when using PTO-driven equipment and always replace the PTO shield if damaged.



CAUTION PROLONGED EXPOSURE TO LOUD NOISE MAY CAUSE PERMANENT HEARING LOSS! Tractors with or without mowers attached can often be noisy enough to cause permanent or partial hearing loss. We recommend that hearing protection be worn at all times when the noise level experienced in the operator's position exceeds 80db. Noise in excess of 85db on a long-term basis can cause permanent total hearing loss. Where the tractor is fitted with a 'quiet cab' it is recommended that the windows are kept closed at all times whilst operating this machine.



In addition to the safety messages stated here the machine is fitted with warning decals that are designed to bring to the attention of the operator the potential dangers that exist whilst using the machine. However, these cannot replace correct proper training and total awareness of all the dangers involved in using a machine of this type, and the nature of the work it does. **BE ALERT, PAY ATTENTION – SOMEONE'S LIFE MAY BE AT STAKE!**

WHEN THIS SYMBOL IS DISPLAYED:



- **BE ALERT**
- **PAY ATTENTION**
- **SOMEONE'S LIFE IS AT STAKE**



Read and Comply with Operator's Manual

Read and understand the Operator's Manual before attaching and operating this machine.



Stop the Tractor before Working on the Machine

Always let the tractor come to a stop, and remove the starter key before you adjust, lubricate, repair or carry out any maintenance work on the machine.



Keep a Safe Distance from the Machine

Danger of flying objects when machine is working. Bystanders must keep a safe distance when the machine is being used.



Beware of Rotating Blades.

Danger of cutting or severing of limbs under covered rotating parts. Do not reach or probe under the machine when it is driven by the tractor.



Machine Lifting Points

When lifting the machine with other than approved tractor attachment points, use the marked lifting points for safe and balanced lifting.



Input PTO Speed

The rated PTO speed for this machine is 540 rpm. For optimum performance, the machine should be driven at this speed. Under no circumstances should this speed be exceeded.



Risk of Hand Entanglement

Rotating parts under cover.

TRACTOR REQUIREMENTS



WARNING: The tractor must have adequate weight and capacity to lift and carry the machine. Local legislation governing this ratio must be observed. The correct ratio between tractor and machine ensures correct braking functions and manoeuvrability. An incorrect ratio between tractor and machine can be dangerous.

PT180 Model ►

PT180 machines are connected to the tractor on the 3 point hitch, and will accept either CAT 1 or CAT 2 linkages. The tractor must also be equipped with a levelling box. If the tractor is fitted with a swinging drawbar, this should be set in its shortest mode or removed completely. The tractor should be equipped with a six-splined PTO and revolve at 540 rpm.



PT240 Model ►

PT240 machines are connected to the tractor on the 3 point hitch, and will accept only CAT 2 linkages. The tractor must also be equipped with a levelling box. If the tractor is fitted with a swinging drawbar, this should be set in its shortest mode or removed completely. The tractor should be equipped with a six-splined PTO and revolve at 540 rpm.



PT270 Model ►

PT270 machines are connected to the tractor on the 2 point hitch, and will accept only CAT 2 linkages. The tractor must also be equipped with a levelling box. If the tractor is fitted with a swinging drawbar, this should be set in its shortest mode or removed completely. The tractor should be equipped with a six-splined PTO and revolve at 540 rpm.



UNPACKING THE MACHINE – PT180 Models



WARNING: Only use approved lifting equipment which is correctly fastened to the machine - this will increase your personal safety. Failure to follow the safety instructions could result in accidents and serious injuries.

Using a Forklift

Guides are provided on the machine to enable movement by forklift. It is essential that the blade carrier and blades are positioned parallel with the fork lift tines. The tines should be fully inserted, angled downwards slightly, with the tips engaging underneath the cross member.

CAUTION: Failure to position the blade carrier and blades correctly can result in damage to the machine.

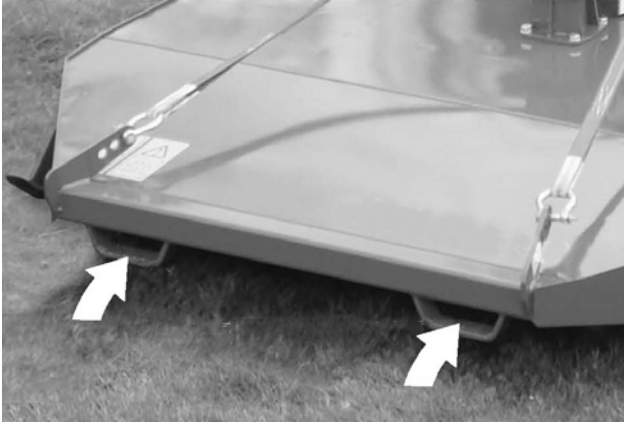

Location of forklift lifting points.

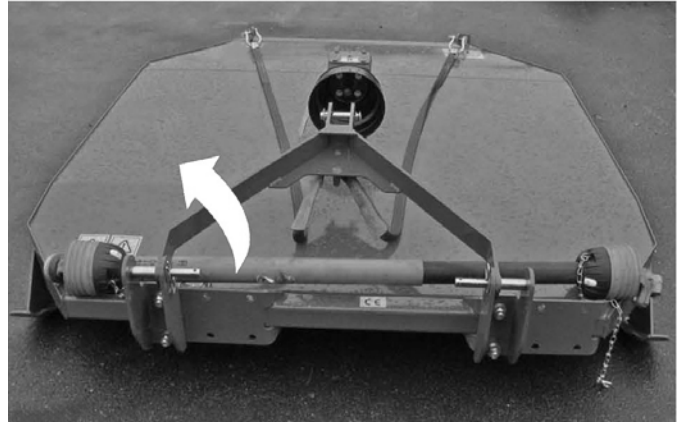

Remove PTO shaft from storage position.



Remove stacking / transport legs (if fitted).

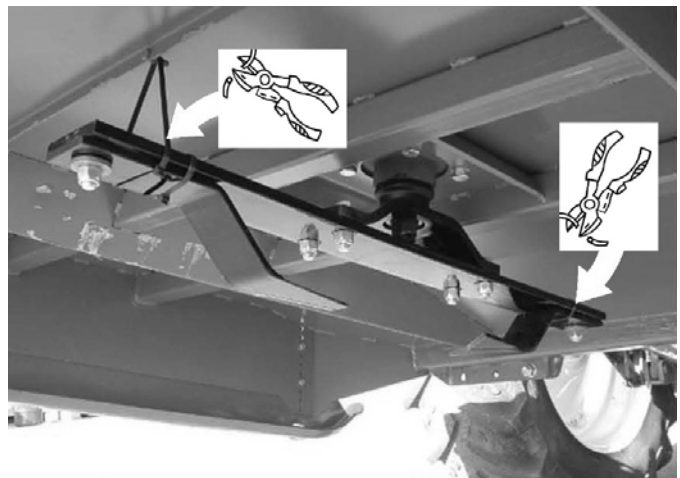

Remove blade restrainer wires / cable ties.

On despatch from the factory the rotors and blades of the machine will be secured with restraining wires and/or cable ties to stop them moving during delivery; these restraining wires must be removed before using the machine.



WARNING: Before attempting to access the underside of the machine, ensure it is adequately and safely supported. Do not rely on the tractor's hydraulics. Use safety supports that have a minimum Safe Working Load (SWL) of 1.5 tonnes.

With the machine suitably supported, remove all rotor and blade restraining wires and/or ties. Inspect the underside of the machine to ensure it is undamaged, and check all blades rotate freely and do not foul on the body.

UNPACKING THE MACHINE – PT240 Models



WARNING: Only use approved lifting equipment which is correctly fastened to the machine - this will increase your personal safety. Failure to follow the safety instructions could result in accidents and serious injuries.

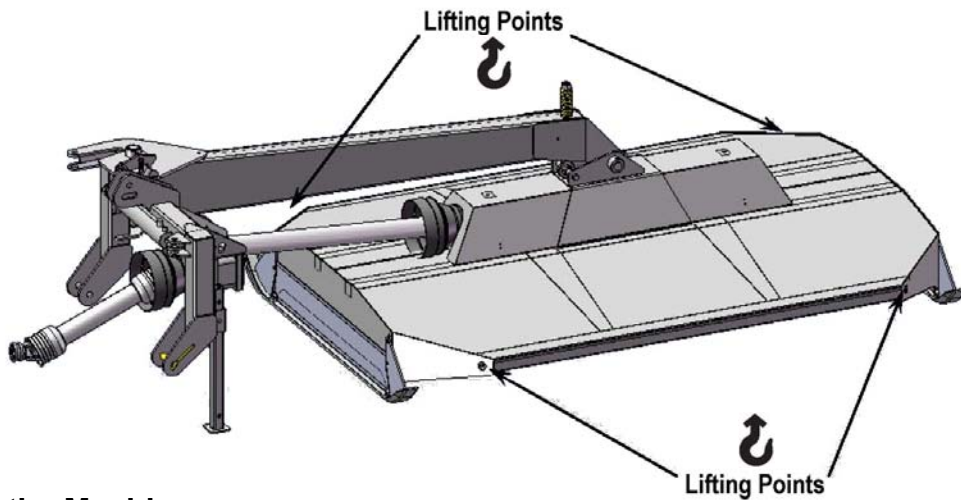

Handling the Machine

The machine should be lifted using suitable overhead lifting gear specifically designed for handling loads of this nature. Ensure lifting equipment has a SWL of 1.5 tonnes minimum. The machine must only be lifted using all four approved lifting points, the locations of which are indicated in the illustration above.

Ensure the machine is evenly balanced before attempting to raise the machine and keep all bystanders at a safe distance from the raised load.

Remove the PTO shaft from its storage position and place it safely away from the machine.

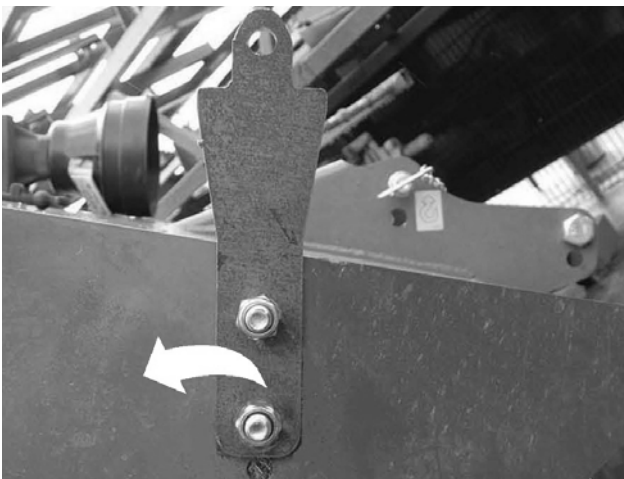

Remove stacking / transport legs (if fitted).

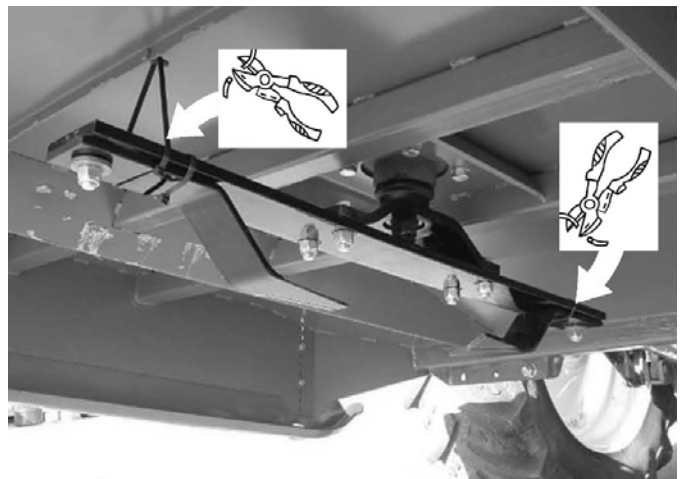

Remove blade restrainer wires / cable ties.

On despatch from the factory the rotors and blades of the machine will be secured with restraining wires and/or cable ties to stop them moving during delivery; these restraining wires must be removed before using the machine.



WARNING: Before attempting to access the underside of the machine, ensure it is adequately and safely supported. Do not rely on the tractor's hydraulics. Use safety supports that have a minimum Safe Working Load (SWL) of 1.5 tonnes.

With the machine suitably supported, remove all rotor and blade restraining wires and/or ties. Inspect the underside of the machine to ensure it is undamaged, and check all blades rotate freely and do not foul on the body.

UNPACKING THE MACHINE – PT270 Models



WARNING: Only use approved lifting equipment which is correctly fastened to the machine - this will increase your personal safety. Failure to follow the safety instructions could result in accidents and serious injuries.

Using a Forklift

Access to two fork guides are provided through the lift arm channels at the front of the machine. This enables movement of the complete unit by forklift.



Forklift lifting points – through lift arm channels.

Remove PTO shaft from its storage position.

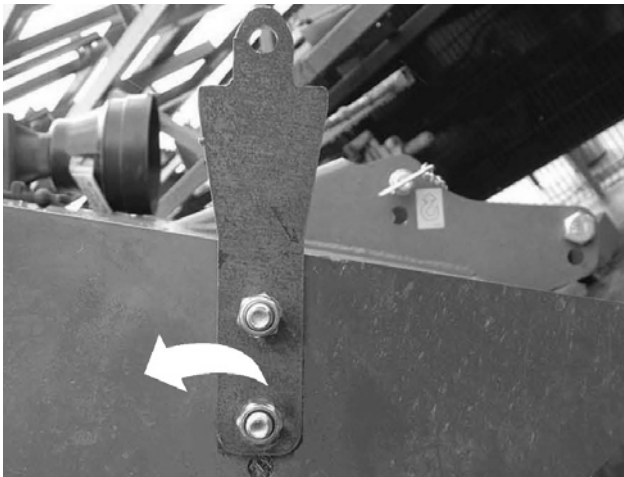

Remove stacking / transport legs (if fitted).

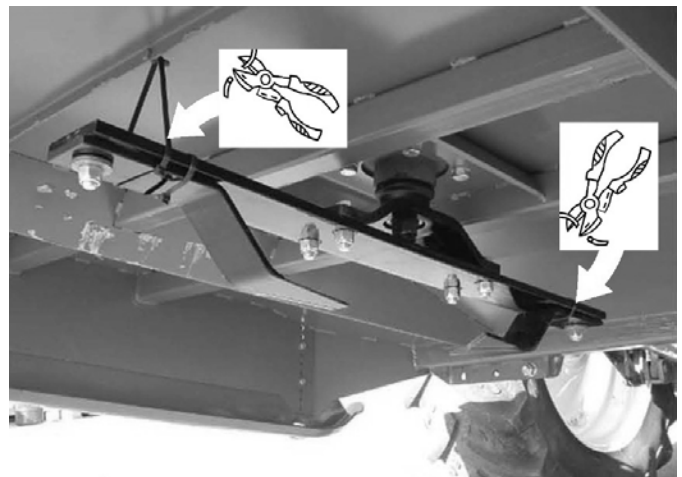

Remove blade restrainer wires / cable ties.

On despatch from the factory the rotors and blades of the machine will be secured with restraining wires and/or cable ties to stop them moving during delivery; these restraining wires must be removed before using the machine.



WARNING: Before attempting to access the underside of the machine, ensure it is adequately and safely supported. Do not rely on the tractor's hydraulics. Use safety supports that have a minimum Safe Working Load (SWL) of 1.5 tonnes.

With the machine suitably supported, remove all rotor and blade restraining wires and/or ties. Inspect the underside of the machine to ensure it is undamaged, and check all blades rotate freely and do not foul on the body.

TRACTOR PREPARATION



WARNING: Ensure that all operators have read and thoroughly understood all the safety procedures. For further information refer to the relevant sections of this manual.



WARNING: When connecting the machine to a tractor there is a risk of personal injury. Failure to follow the safety instructions could result in serious injuries to either yourself or others. Therefore, when connecting the machine and the tractor you should:

- ✓ Make sure the tractor cannot roll.
- ✓ Make sure that the tractor and the machine have compatible category attachments.
- ✓ Never stand between the tractor and the machine during attachment.
- ✓ Use the hydraulic three point linkage slowly and carefully.
- ✓ When carrying out an attachment you must make sure that the machine is placed on a firm and level surface.



Remove tractor drawbar or position it to one side so it does not foul on the PTO shaft

ATTACHING THE MACHINE – PT180 Models

Attachment of the machine should be performed on a firm level site - the procedure for attachment is as follows;

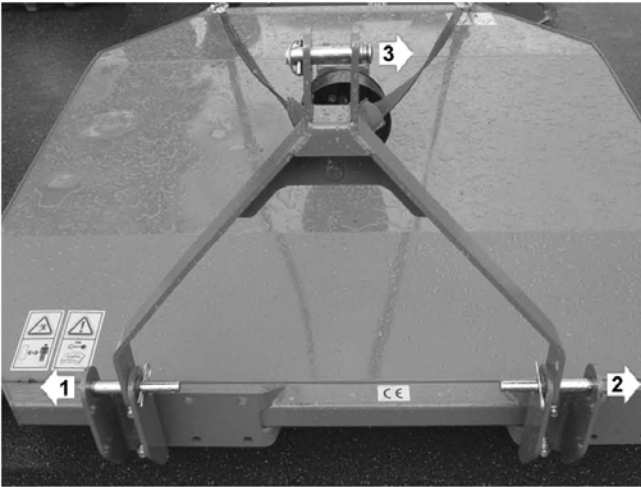

Support the 'A' frame and remove the 3 link pins before reversing the tractor up to the machine - adjust lift arm height to align with the pin holes on the machine.

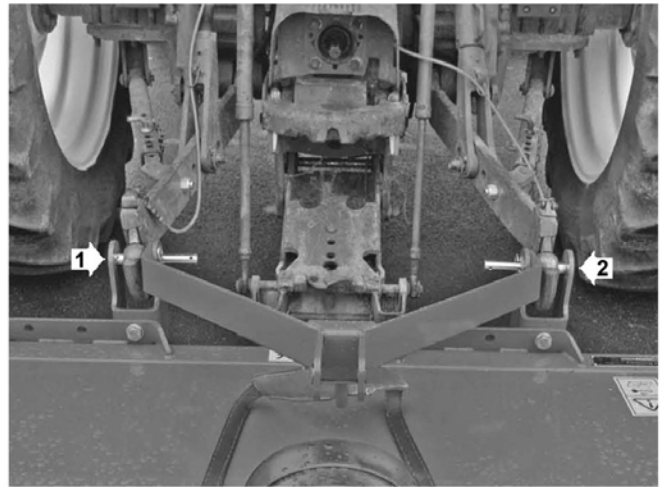

Turn off the tractor, apply parking brake and remove the starting key. Attach lower lift arms and 'A' frame to the machine using the Cat I/II pins supplied.

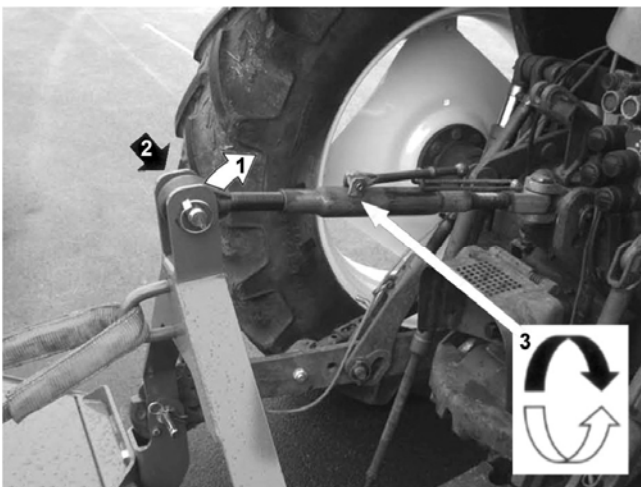

Raise 'A' frame into the position shown and fit the top link. Adjust the length of the link to remove any slack and to tension the transport strap, without lifting the rear of the machine off the ground.



Start the tractor and raise the machine on the lift arms until the gearbox PTO shaft of the machine and the tractor PTO are at their shortest distance apart. Turn off the tractor, apply parking brake and remove the starter key.

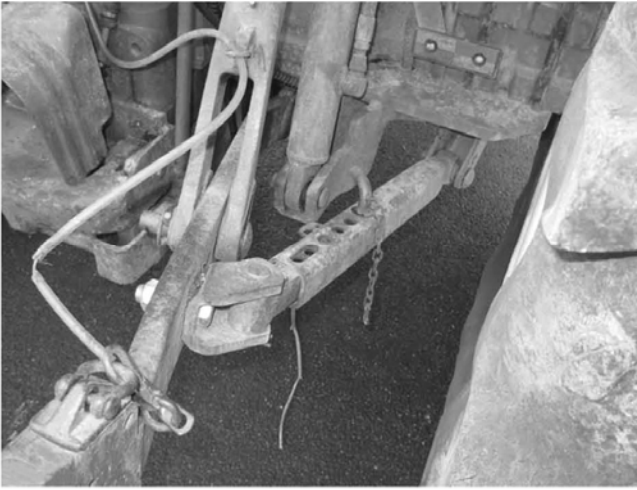

Adjust the tractor stabiliser chains/bars to remove any lateral movement when the machine is in the raised position.

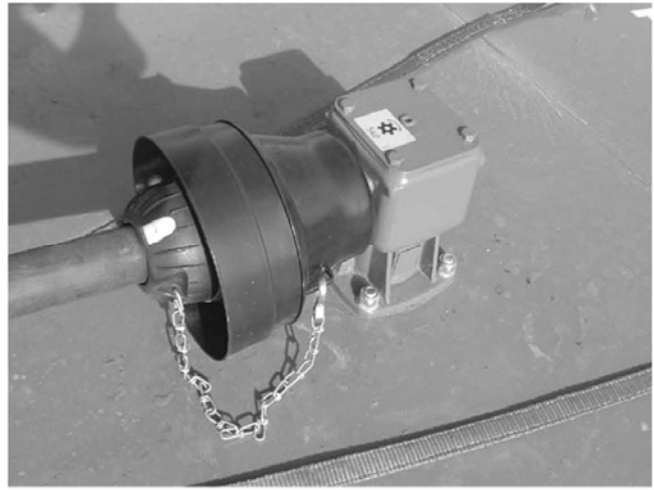

Connect the end of the PTO shaft that has the shear bolt to the machine's gearbox. Secure the PTO guard retraining chain to a suitable location on the machine.

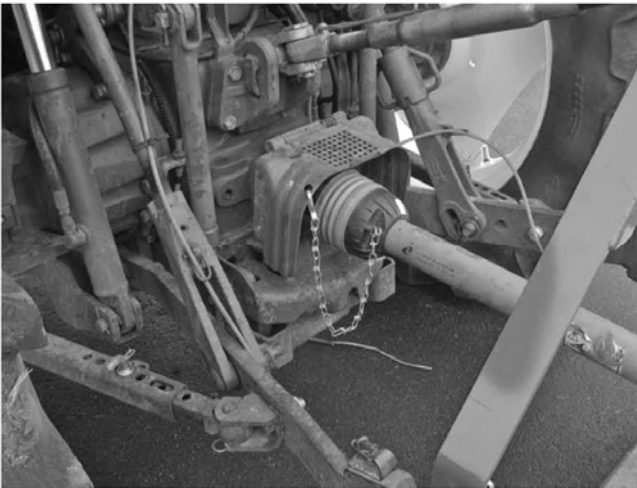

Connect the other end of the PTO shaft to the tractor's PTO drive. Secure the PTO guard retraining chain to a suitable location on the tractor.

NOTE: On initial installation the PTO shaft length may need adjusting to suit this particular application; refer to *PTO driveshaft installation* page for details of this procedure.

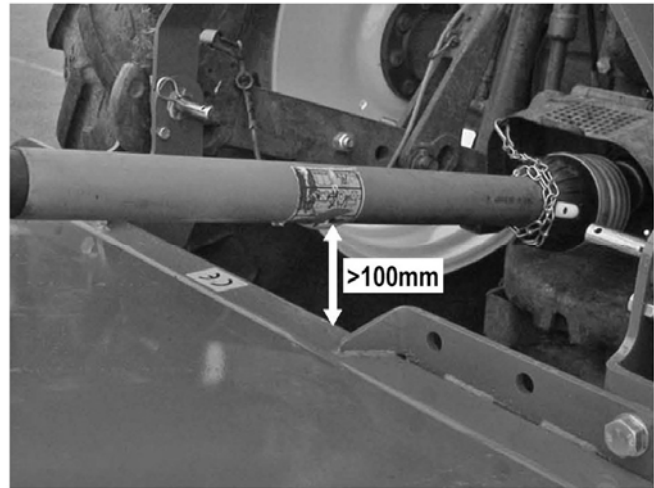

With the PTO shaft correctly connected, raise the machine to a safe transport position. Ensure a clearance of at least 100mm between the underside of the shaft and the body of the machine whilst in the transport position. Lock the 'lift arm stop' in this position.

Check that there is no lateral movement on the machine when it is in the raised position; adjust the stabiliser chains/bars if required.



CAUTION: Raising the tractor lift arms too high may cause damage to the PTO shaft if the tractor was to drive over any bumps and the machine was to bounce on the lift arms.



WARNING: Read all the safety instructions carefully before driving on the public road and always comply with the local law concerning lights, warning and safety signs. The driver and/or the owner of the machine have the responsibility of complying with the local Road Traffic Acts.

Always ensure tractor manoeuvrability is not adversely affected by any attached machinery; the steering axle of the tractor should be loaded with at least 20% of the tractor's dead weight. Carrying of passengers on the machine is strictly prohibited.

ATTACHING THE MACHINE – PT240 Models

Attachment of the machine should be performed on a firm level site - the procedure for attachment is as follows;

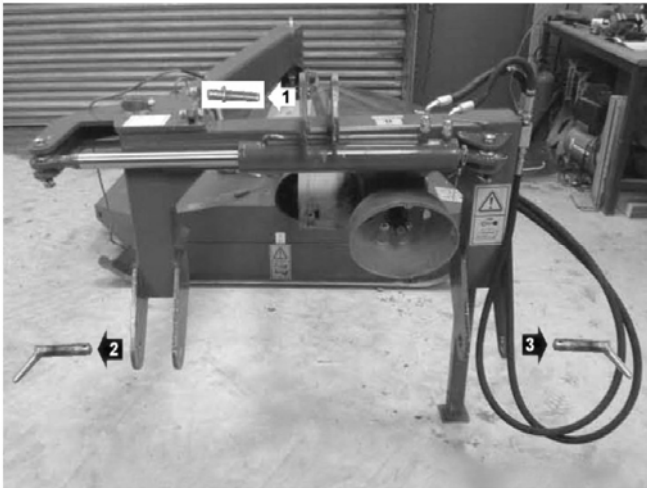

Remove the top link pin (1) and the two Cat II pins (2 & 3).

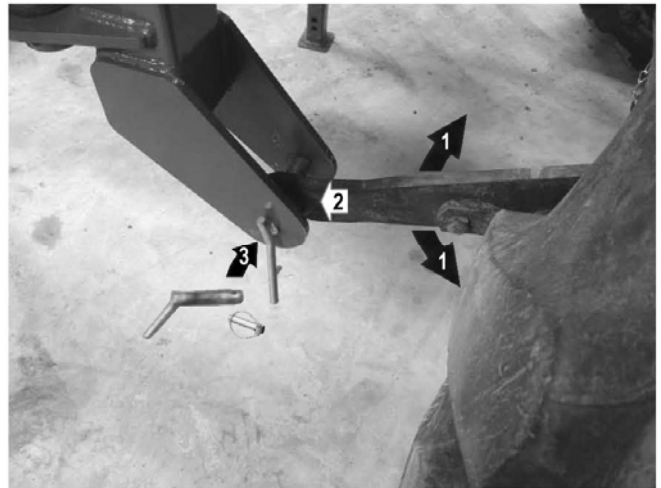

Reverse tractor slowly up to the machine - adjust the lift arm height to align with the pin holes. Turn off the tractor, apply the parking brake and remove the starter key. Attach lower link arms to the machine using the Cat II pins supplied and secure with lock pins.

NOTE: Adjust and attach the Left Hand Lift Arm by using the tractor Levelling Box if necessary.



Attach the tractor top link to the single hole in the top of the headstock using the top link pin provided and secure with lock pin.

Start the tractor and raise the machine on the lift arms until the gearbox PTO shaft of the machine and the tractor PTO are at their shortest distance apart. Turn off the tractor, apply parking brake and remove the starter key.



Adjust the tractor stabiliser chains/bars to remove any lateral movement when the machine is in the raised position.



Remove parking leg pin and raise the leg clear of the ground – replace pin and secure with lock pin.

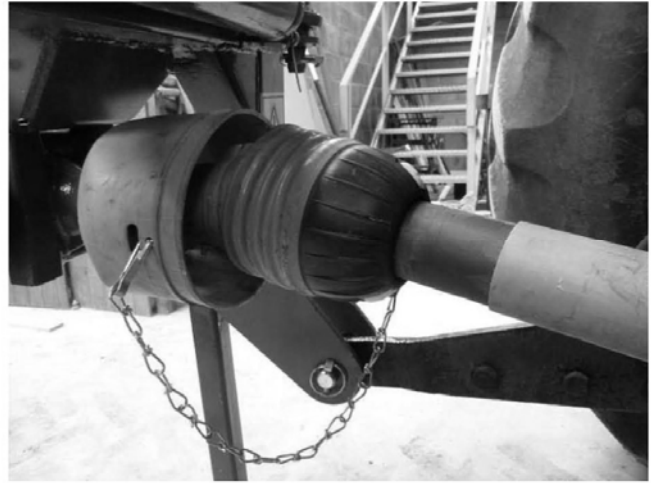

Connect the end of the PTO shaft that has the shear bolt to the machine. Secure the PTO guard retraining chain to a suitable location on the machine.



Connect the other end of the PTO shaft to the tractor's PTO drive. Secure the PTO guard retraining chain to a suitable location on the tractor.

NOTE: On initial installation the PTO shaft length may need adjusting to suit this particular application; refer to *PTO driveshaft installation* page for details of this procedure.

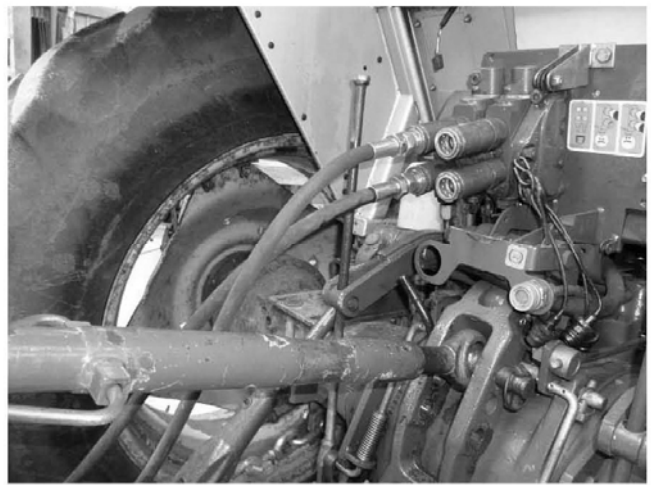

Connect the hydraulic hose fittings to the tractor spool valve.



Unpack the Transport Latch Pull Cord and route it into the tractor cab through the rear window – it should be located in a position that is within easy reach of the operator from the tractor seat.



Ensure the routing of the cord is such that it allows sufficient slack to avoid accidental or unintentional operation, and that it remains clear of all moving components on both the tractor and the machine at all times.

ATTACHING THE MACHINE – PT270 Models

Attachment of the machine should be performed on a firm level site - the procedure for attachment is as follows;

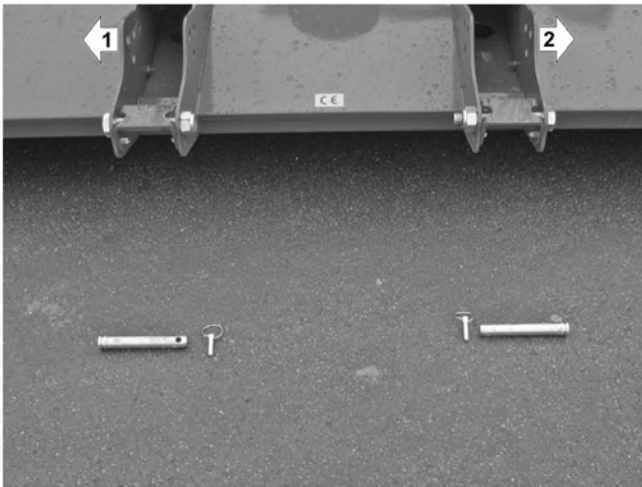

Remove the two Cat II link pins and reverse the tractor up to the machine - adjust the height of the lift arms so they align with the pin holes on the machine.

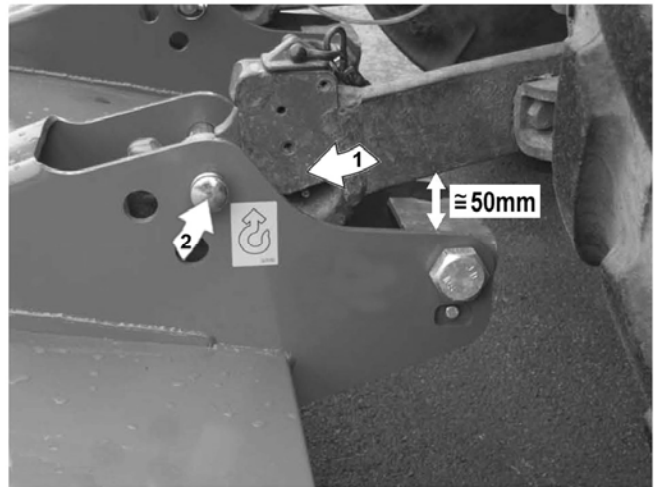

Carefully reverse the tractor fully in to locate the lift arms within the receiving channels of the machine and attach in position using the Cat II pins supplied. The machine has 3 pin positions – select the one that gives approximately 50mm clearance between lower lift arm and machine.

NOTE: An insufficient amount of clearance will prevent the machine from 'floating' correctly.

Start the tractor and raise the machine on the lift arms until the gearbox PTO shaft of the machine and the tractor's PTO drive are at their shortest distance apart. Turn off the tractor, apply the parking brake and remove the starter key.



Adjust the tractor stabiliser chains/bars so there is no lateral movement when the machine is in the raised position.

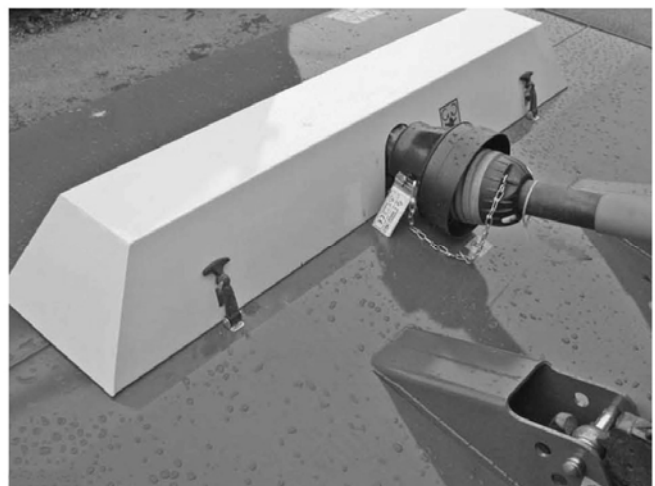

Connect the end of the PTO shaft that has the shear bolt to the machine's gearbox. Secure the PTO guard retraining chain to a suitable location on the machine.

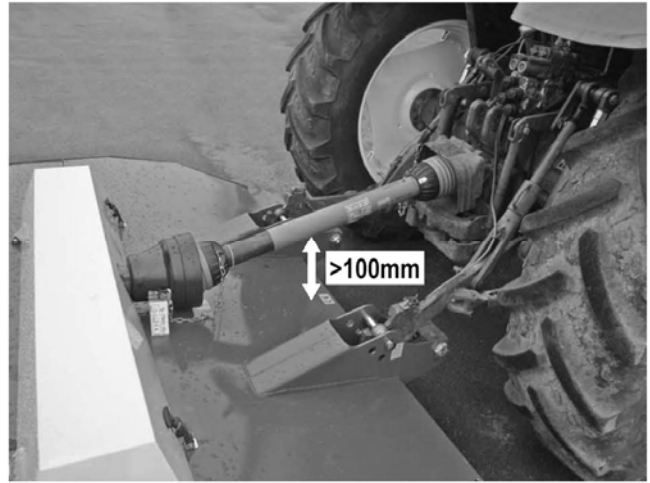
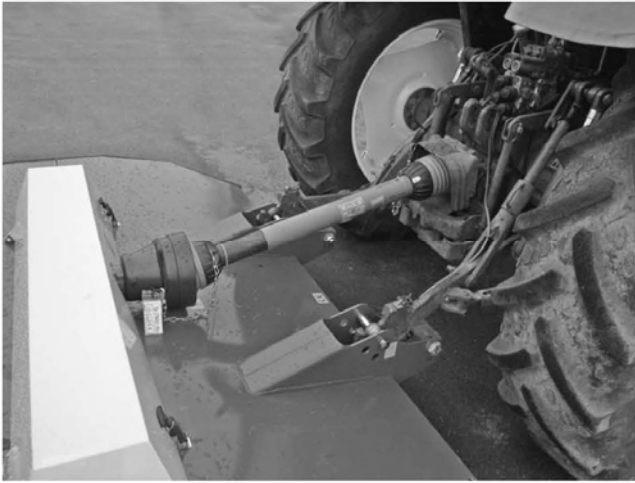

Connect the other end of the PTO shaft to the tractor's PTO drive. Secure the PTO guard retraining chain to a suitable location on the tractor.

NOTE: On initial installation the PTO shaft length may need adjusting to suit this particular application; refer to *PTO driveshaft installation* page for details of this procedure.

With the PTO shaft correctly connected, raise the machine to a safe transport position. Ensure a clearance of at least 100mm between the underside of the shaft and the body of the machine whilst in the transport position. Lock the 'lift arm stop' in this position.

Check that there is no lateral movement on the machine when it is in the raised position; adjust the stabiliser chains/bars if required.



CAUTION: Raising the tractor lift arms too high may cause damage to the PTO shaft if the tractor was to drive over any bumps and the machine was to bounce on the lift arms.



WARNING: Read all the safety instructions carefully before driving on the public road and always comply with the local law concerning lights, warning and safety signs. The driver and/or the owner of the machine have the responsibility of complying with the local Road Traffic Acts.

Always ensure tractor manoeuvrability is not adversely affected by any attached machinery; the steering axle of the tractor should be loaded with at least 20% of the tractor's dead weight. Carrying of passengers on the machine is strictly prohibited.

PTO DRIVESHAFT INSTALLATION

The PTO driveshaft attaches between the tractor and the machine gearbox to transfer the power required to run and operate the machine – it is important to achieve the correct shaft length to avoid risk of it ‘bottoming out’ when raising or lowering the machine. The procedure for measuring and cutting the shaft is as follows;

Measuring the PTO Shaft

With the machine attached to the tractor in the working position measure the horizontal distance ‘A’ from the tractor’s PTO to the input shaft on the machines gearbox and subtract 75mm (3”) – *this figure is the required shaft length.*

Place the fully closed PTO shaft on the ground and measure its overall length, if the shaft is shorter than the required length you can use it without the need to shorten - *providing it allows for a minimum 150mm (6”) overlap when fitted.*

If the shaft is longer subtract the required shaft length plus an additional 75mm (3”) - *the resulting figure is the excess length that will need to be removed from each half of the shaft.*

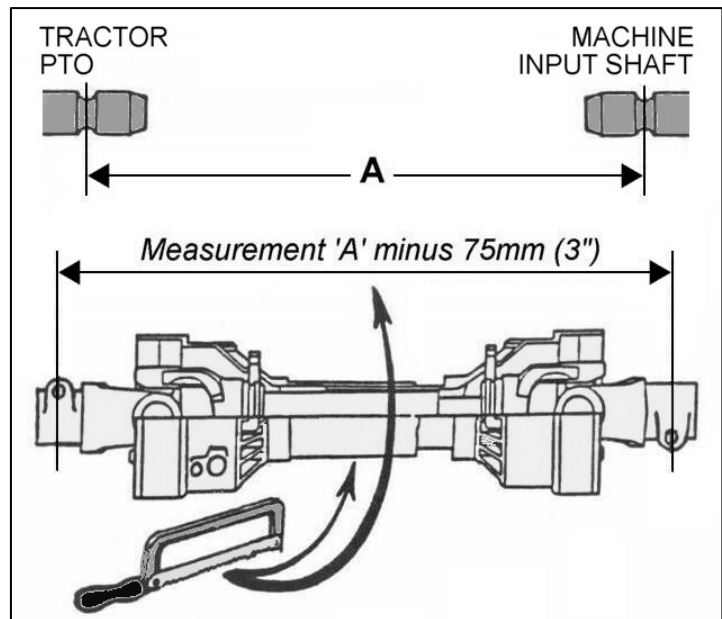

Cutting the PTO Shaft

Separate the two halves and using the measurement obtained above shorten both the plastic guarding and the inner steel profile tubes of each shaft by this same amount. De-burr the cut tubes with a file to remove rough or sharp edges and thoroughly clean to remove swarf before greasing, assembling and fitting the shaft.

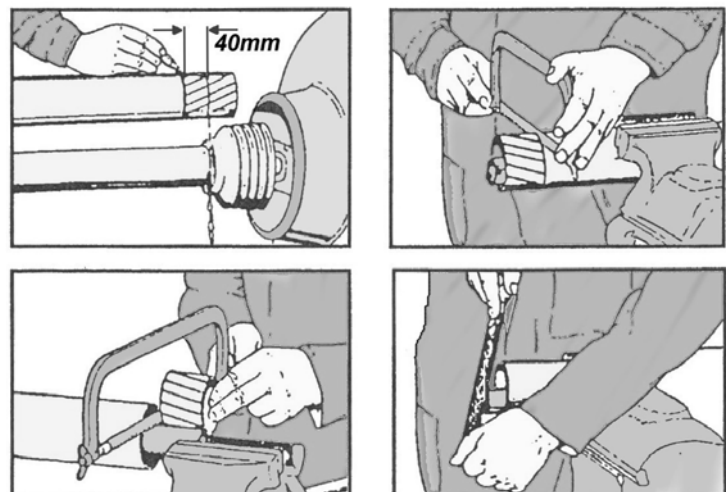

NOTE: For subsequent use with different tractors the shaft should be measured again to check suitability – *there must be a minimum shaft overlap of 150mm (6”).*

PTO Maintenance

To increase the working life of the PTO shaft it should be periodically checked, cleaned and lubricated – *refer to the manufacturer’s manual provided with the shaft for further details on this subject.*

MACHINE DISCONNECTION & STORAGE

Disconnecting the Machine

Disconnection of the machine is a reversal of the attachment procedure – *refer to the attachment sections for details.*



WARNING:

There is an increased risk of injury when disconnecting the machine from the tractor. Before attempting to disconnect the machine, make sure that:

- ✓ The machine is placed on a firm and level surface.
- ✓ The tractor cannot roll after being disconnected.
- ✓ The tractor has stopped, the parking brake is applied and the starter key is removed.
- ✓ The machine has come to a complete stop before commencing work.
- ✓ Bystanders are kept at a safe distance from the machine and tractor.
- ✓ Before leaving the machine ensure it is left in a safe condition.
- ✓ Do not allow children to play on or near the machine, even when it is disconnected; there are moveable components on the machine that can risk injury.

Machine Storage

At the end of the season the machine should be readied for winter storage. The storage location is ideally in a dry well ventilated building that will offer the machine protection from the elements. Before placing the machine into storage the following tasks should be performed;

- Clean the machine thoroughly.
- Check that the machine's safety equipment is not worn or damaged - replace if required.
- Clean and lubricate the PTO shaft and store it in a safe dry environment to avoid risk of damage or corrosion.
- Repair or replace any damaged components.
- Replace any defective components.
- Check and tighten all bolts.
- Lubricate the machine following the lubrication program.
- Repair any paint damage and replace any missing decals.

When storing or parking the machine always ensure it is left in a safe condition without risk of harm or injury to persons or animals, if necessary use suitable props or blocks to support the machine.

TRANSPORTING THE MACHINE

For transportation between work sites the machine should be raised to a suitable carrying height and the tractors 'lift arms stops' locked at that position; on PT180 & PT270 models ensure a minimum clearance distance of 100mm is retained between the underside of the PTO shaft and the body of the machine - see photos below.

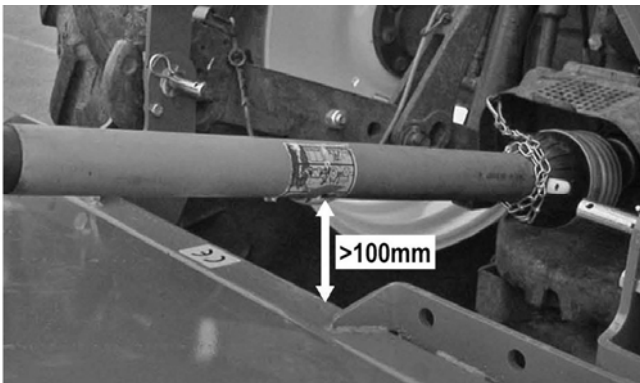

PT180 – PTO shaft clearance required for transport

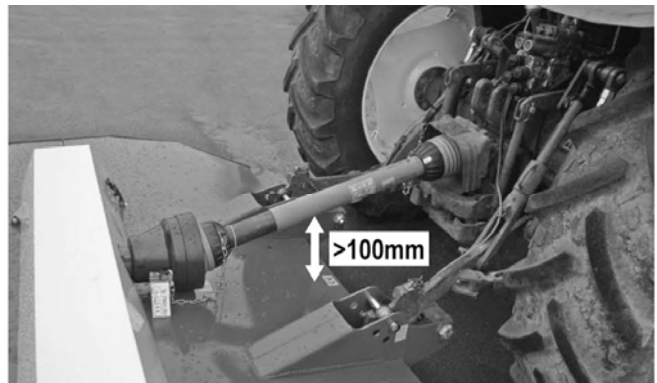

PT270 – PTO shaft clearance required for transport



PT240 – Transport Position



WARNING: Read all the safety instructions carefully before driving on the public road and always comply with the local law concerning lights, warning and safety signs. The driver and/or the owner of the machine have the responsibility of complying with the local Road Traffic Acts.

Always ensure tractor manoeuvrability is not adversely affected by any attached machinery; the steering axle of the tractor should be loaded with at least 20% of the tractor's dead weight. Carrying of passengers on the machine is strictly prohibited.

Before Driving on Public Roads

The machine should be raised on the lift arms to the transport position and the following checks made:

- Is the machine correctly coupled with all securing pins and clips in position?
- Does the machine have any loose or unsecured parts?
- Are the tractor's lights, indicators and beacon working correctly and are they all clearly visible?
- Are there any bystanders or children in the immediate area? If so, ask them to clear the area before moving off.

Driving on Public Roads

- Check the area around the machine before you start. Be aware of children in the danger area of the machine.
- Do not exceed 30 km/h.
- Adjust the speed according to the road conditions.
- Avoid sudden sideways movement with the machine attached.
- Make sure that steering and braking ability are not compromised.
- Take care when turning corners as the machine may swing out into the path of other road users.

MOVING FROM TRANSPORT TO WORK POSITION – PT240 Models



Ensure that the machine and the PTO shaft have been correctly connected to the tractor. For further information refer to the 'Machine Attachment' section.



Ensure that the immediate surroundings will not cause a restriction to the moving and checking of the machine.



Ensure there are no children, bystanders or animals within the immediate area of the machine.

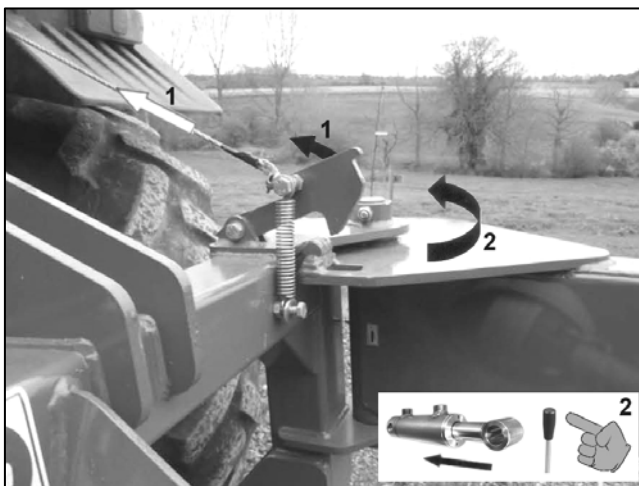

With the machine raised clear of the ground by approximately 100mm pull the transport latch release cord and carefully operate the hydraulic spool valve to retract the hydraulic ram, this will pull the swing arm through 90° and place the deck of the machine in the work position on the right hand side of the tractor.



Lower the machine so the skids are resting on the ground, apply handbrake and turn off the tractor engine.

Remove the top link pin from the single hole on the headstock and reposition the top link with the pin in the slotted hole directly below; this will allow better floatation when operating the machine.

NOTE: To operate the machine with the hydraulic safety breakback feature, the hydraulic spool lever should be in "float" position. This gives free flow of oil return to the tractor should an obstacle be encountered.



WARNING: Failure to operate without free float return to the tractor may result in serious damage to your machine.

The procedure for moving the machine from working position to transport position is the reverse of the above procedure. The Transport Latch will automatically lock the swing arm in position when the ram is fully extended.



WARNING: At no time should the machine be moved from working to transport position whilst the PTO is engaged, or the machine is running down. Ensure the rotors are at a complete standstill before moving swing arm. Failure to observe this guidance is likely to cause serious driveline damage.

'RUNNING UP' THE MACHINE

Before Use



WARNING:

Ensure that all operators have read and thoroughly understood all the safety procedures. For further information refer to the relevant sections of this manual.

Running the Machine for the First Time



Ensure that the machine and the PTO shaft have been correctly connected to the tractor as stated in the 'machine attachment sections' of this manual.



Select a safe open area in which to 'run-up' and check the machine. Ensure there are no children, bystanders or animals in the immediate area when the machine is run for the first time.

After the machine has been attached to the tractor for the first time, it should be tested to ensure it operates correctly before putting it to work. Use the following procedure when running the machine for the first time.

1. Lower the machine so the skids are resting on the ground and the machine is level.
2. With the tractor at low revs, gently engage the PTO until the machine is running.
3. Carefully increase the PTO speed to 540 rpm.
4. Check that the machine runs smoothly and without vibration.
5. Raise the machine to the transport position.
6. Check again that the machine runs smoothly and without vibration.
7. Lower the machine to ground level again.
8. Gently reduce the tractor revs to idle, and disengage the PTO.
9. Apply the parking brake and stop the tractor.

If any faults are identified, refer to the 'Troubleshooting Guide'; *if a solution is still not found consult your local McConnel Dealer for assistance.*

MACHINE OPERATION

Operating the Machine

Upon arrival at the location to be topped, lower the machine fully so that both skids are sat on the ground.

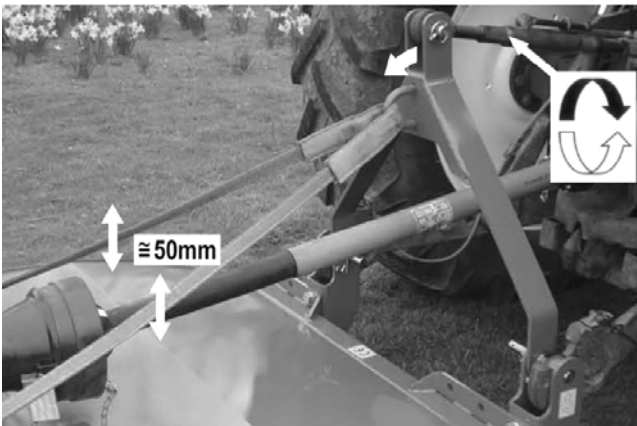
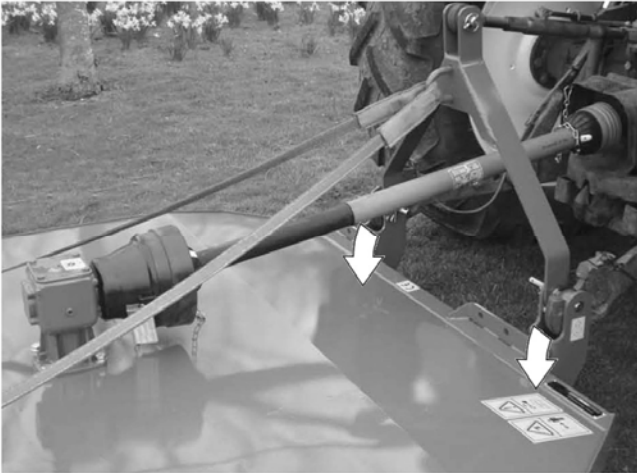

PT180 models only; adjust top link to slacken off transport strap (*approximately 50mm play*).

PT240 models only; ensure top link is located and secured by pin in slotted hole on headstock.

- Lift the machine so it clears the ground by approximately 100mm then gently engage the PTO and run at tick-over speed.
- Lower the machine to the ground, and increase the PTO speed to 540 rpm.
- Select a forward speed that is suitable for the ground conditions and the type of material to be cut.
- Check the machine is 'floating' correctly. Ensure on PT240 models that the top link is attached with its pin in the slotted hole on the headstock to allow better flotation.
NOTE: When turning at headlands, lift the machine so the skids just clear the ground. This will reduce field damage in wet conditions.
- If the stubble height is not correct, adjust the skid height accordingly - *refer to 'Machine Settings and Adjustments'*.

Stopping the Machine

When stopping the machine, use the following procedure:

- Reduce forward speed and bring the tractor to a halt.
- Keep the machine lowered onto the ground.
- Reduce engine revs to idle speed, and disengage the PTO.
- When the rotor has stopped turning, raise the machine to the transport position.

Machine Settings & Adjustments



WARNING: Before working on any component of an attached machine, ensure that the tractor engine is turned off and the starter key removed to prevent anyone else from starting the tractor whilst it is being worked on.

WARNING: Always 'park up' on a suitable firm, level surface with the parking brake applied, and ensure the machine has come to a complete stop before adjusting or setting the machine.

WARNING: Before attempting to access the underside of the machine, ensure it is adequately and safely supported. Do not rely on the tractor's hydraulics. Use safety supports that have a minimum Safe Working Load (SWL) of 1.5 tonnes.

Cutting Height Adjustment

The cutting height of the pasture topper can be adjusted to cut at heights from 30mm to 150mm. This is achieved by moving the bolt-on skids at each side of the machine to the desired height position – see *photo below*.

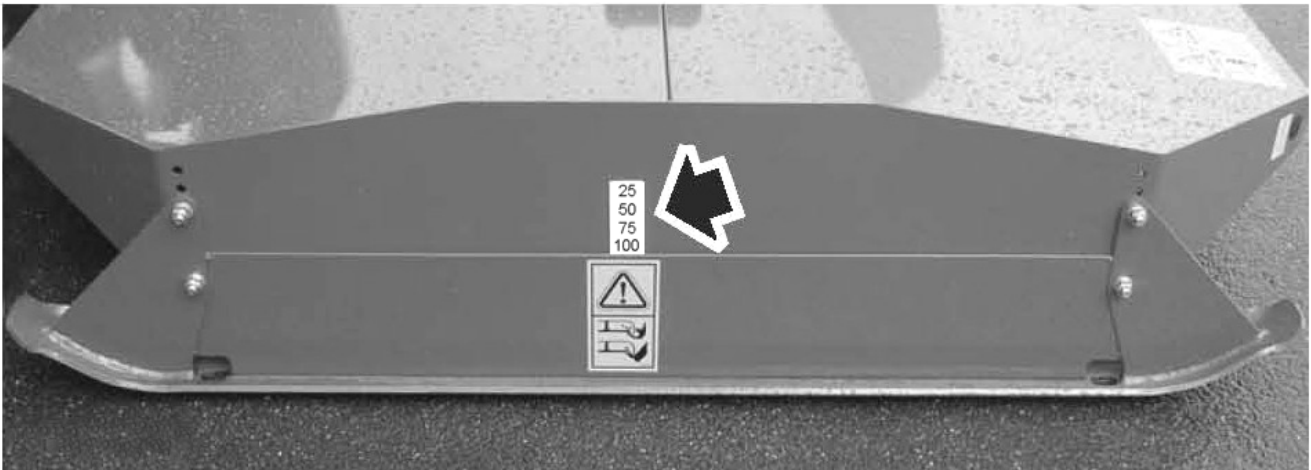

WARNING: Request assistance when removing and replacing the skids, they are heavy and may cause injury.

To adjust the cutting height:

- Raise the machine on the tractor lift arms and support it on suitable safety supports.
- Remove the nuts, bolts and washers securing the skid to the machine.
- Reposition the skid to the new desired position; use the cutting height decals on the side of the machine (*indicated in the photo above*) as a guide.
- Fit and tighten all nuts and bolts securely, see 'Torque Settings'.
- Repeat the process for the other skid, ensuring that both skids are at the same height setting.
- Raise the machine on the lift arms and remove the safety supports.

Re-try the machine and re-adjust the skid height if the cutting height is still not suitable.

Headstock Position *(PT180 Models only)*

PT180 models can be offset to the right in 2 increments of 112mm. This means the machine can be used so that only one tractor wheel is running on uncut material in front of the machine and may also be useful for cutting underneath low cover, for example at the edges of hedgerows.

1. Normal position
2. Offset Position #1 (112mm to the right)
3. Offset Position #2 (224mm to the right)

NOTE: In the normal position the PTO shafts on the tractor and on the machine will be in line.

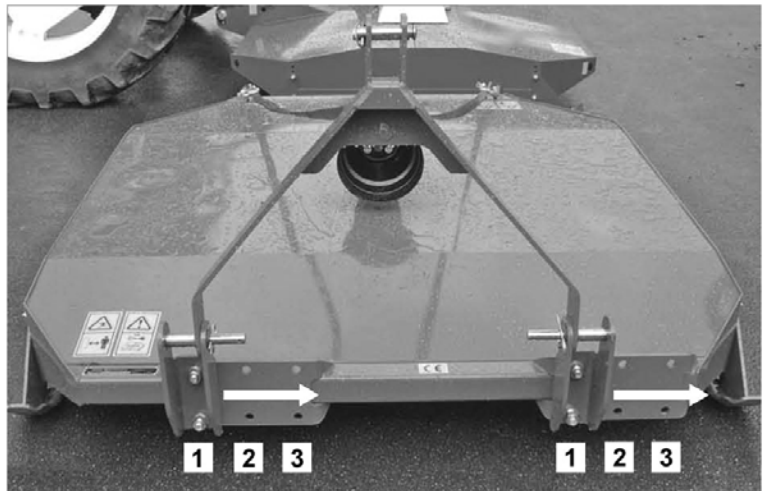

Adjusting Headstock Position

The procedure for adjusting the headstock position is as follows;

- Disconnect the machine from the tractor.
- Lower the 'A' frame.
- Remove all nuts, bolts and washers that secure the left and right headstock brackets to the machine.
- Reposition the headstock assembly at the desired position.
- Re-fit all nuts, bolts and washers and tighten securely, see 'Torque Settings'.
- Re-attach the machine to the tractor.

SHEAR BOLT PROTECTION

The PTO shaft is fitted with a shear bolt overload protection to prevent damage to the machine if an obstacle is encountered during operation. The shear bolt is located at the machine end of the PTO shaft.

Shear Bolt location ►

The procedure below should be followed when replacing or inspecting the shear bolt.



Inspecting and/or Replacing the Shear Bolt

- Disengage the PTO.
- Park up and lower the machine on a firm level site.
- Switch off the tractor, apply the parking brakes and remove the starting key.
- Release the PTO guard restraining chains and disconnect the PTO shaft from the tractor end first, and then from the machine; this will now give access to the shear bolt for inspection and replacement.
- Inspect the machine, shaft and work area for possible causes of failure. Check that the blades rotate freely and are not fouling on the body.
- Remove any bolt remains from the universal joint, and replace the shear bolt with the correct grade replacement. Tighten the bolt to the correct torque setting.
- Re-connect the shaft to the machine and then to the tractor and attach the guard restraining chains.
- Re-start the machine using the same procedure as for 'Running the Machine for the First Time' to check that it operates correctly.



CAUTION: Only use the same size and grade of shear bolt as originally supplied with the machine - *refer to the parts manual for genuine replacements.*

NOTE: Four spare shear bolts and nuts are supplied with the machine; these are to be found on the top of the 'A' frame assembly.

CLEANING THE MACHINE



WARNING: Always pay attention to the area and environment when carrying out any cleaning work; this will reduce the risk of injury to you and others.
Before cleaning: Check the area around the machine for hazardous or loose material.

Cleaning Procedure

- Lower the machine to the ground.
- Apply the parking brake and stop the tractor.
- Remove the starter key from the tractor.
- Disconnect the PTO shaft.
- If the machine needs to be raised for cleaning ensure it is safely and suitably supported.
- Always wear Personal Protective Equipment (PPE).
- Wear the correct protective gear for body and face when cleaning the machine, this will protect you from dirt and oil splashes. Insufficient protection of body and face can lead to severe skin and eye injuries.

Cleaning Agents



CAUTION: Some cleaning products contain chemicals that are hazardous to the environment. Always take precautions to prevent spillage of fluids while cleaning.



CAUTION: Only use pH neutral cleaning agents when cleaning the machine. pH neutral cleaning agents give your machine maximum protection. Cleaning agents with either high or low pH value can be corrosive on plastic, rubber and varnished surfaces.



CAUTION: High pressure cleaning equipment may be used to clean the machine but must be used with care to avoid risk of damaging paintwork and decals. Areas around the bearings should be cleaned using gentle squirts of water.

After cleaning allow the machine to dry off completely and lubricate it fully before using it for work or placing it into storage.

MAINTENANCE

Regular Maintenance

Regular maintenance carried out at the intervals specified in the maintenance chart below will ensure that the machine operates correctly and safely and minimise operational down time. *See following page for maintenance safety before attempting to work on the machine.*

After 1 Hour of Use (New Machine)

- Check all gearbox mounting bolts for tightness - *tighten if required.*
- Check mounting bolts on blade carrier(s) - *tighten if required.*
- Check headstock mounting bolts for tightness - *tighten if required.*

After 10 Hours of Use (New Machine)

- Check gearbox oil level(s) - *top up if required.*
- Check blades for damage.
- Check blade bushes for wear.
- Check headstock mounting bolts for tightness - *tighten if required.*

Maintenance Schedule

MACHINE COMPONENT	MAINTENANCE INTERVAL			
	Weekly	Fortnightly	Monthly	Annually
PTO Shaft				
Inspect and lubricate – <i>refer to manufacturer's manual</i>	•			•
Centre Gearboxes				
Check mounting bolts – <i>tighten if required</i>	•			•
Check oil level – <i>top up if required</i>		•		•
Replace oil – <i>drain and refill</i>				•
Outer Gearboxes (where applicable)				
Check mounting bolts – <i>tighten if required</i>	•			•
Check oil level – <i>top up if required</i>		•		•
Replace oil – <i>drain and refill</i>				•
Blade Carrier				
Check mounting bolts – <i>tighten if required</i>	•			•
Blades				
Check for damage or wear	•			•
Check bushes for wear			•	•
Headstock (where applicable)				
Check mounting bolts – <i>tighten if required</i>		•		•
Flexible Couplings (where applicable)				
Check for cracks and damage	•			•
Fasteners				
Check tightness and condition of fasteners and fittings			•	•

Power Take Off (PTO) Shaft

Refer to the PTO Shaft Manufacturer's instructions for adjusting or servicing this component; the instruction booklet will be attached to the new shaft on delivery of the machine.

Maintenance Safety



WARNING: Before attempting to access the underside of the machine, ensure it is adequately and safely supported. Do not rely on the tractor's hydraulics. Use safety supports that have a minimum Safe Working Load (SWL) of 1.5 tonnes.

WARNING: Repair and maintenance work should only be performed if you have the necessary professional knowledge, the proper tools and comply with the following guidance:

- Always park the machine on a suitable firm, level surface with the parking brake applied.
- Ensure the tractor engine is turned off and the starter key removed to prevent anyone else from starting the tractor while it is being worked on.
- Disconnect the PTO shaft.
- Never work between the tractor and the machine if the machine has not been secured.
- Always use original spare parts on the machine.

Lubricating Oil Precautions



WARNING: Avoid excessive skin contact with used oil. Used oil contains potentially harmful contaminants which may cause skin cancer or other serious skin disorders. Avoid excessive skin contact with used lubricating oils and always adhere to the health protection precautions.

- Avoid prolonged and repeated contact with oils, particularly used engine oils.
- Wear protective clothing, including impervious gloves where practicable.
- Avoid contaminating clothes with oil (particularly those next to the skin). Overalls must be cleaned regularly. Discard heavily soiled clothing and oil impregnated footwear.
- First aid treatment should be obtained immediately for open cuts and wounds.
- Apply barrier creams before each work period, to help prevent lubricating oil from contaminating the skin.
- Use moisturisers after cleaning; preparations containing lanolin help replace the skin's natural oils which have been removed.
- If skin disorders develop, obtain medical advice without delay.
- Wear eye protection (e.g. goggles or a face shield) if there is a risk of eye contamination. Eye wash facilities should be provided in close vicinity of the work area.

NOTE: Used oil must be collected in a suitable container and delivered to a registered disposal company, where the oil will be processed according to the governing regulations.

Gearbox Maintenance – PT180 Model

Gearbox Mountings Bolts

Check the gearbox mounting nuts and bolts at the intervals stated in the maintenance schedule and retighten if required. Locations of the mounting nuts and bolts are indicated in the photo below left.

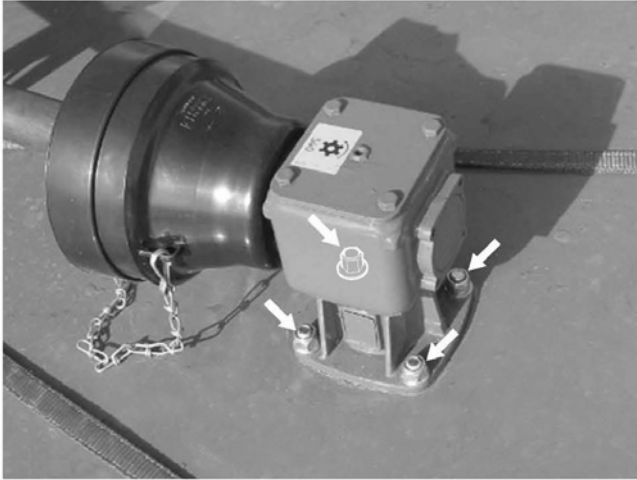

Gearbox mounting nuts and bolts location

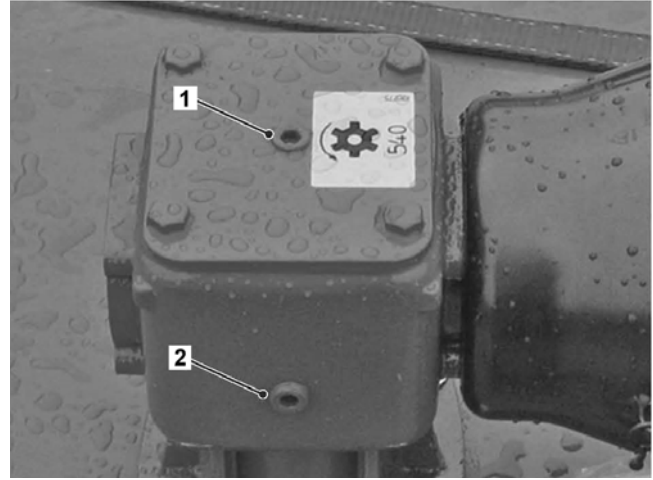

1) Oil Filler Plug 2) Oil Level Plug

Oil Level

Check the gearbox oil level at the intervals stated in the maintenance schedule; ensure the machine is lowered to the ground and located on a firm level site to perform this task.

Checking the oil level in the gearbox is by removal of the Oil Level Plug, indicated '2' in the photo above right, the level is correct when the oil is up to the bottom of the level plug orifice. If the gearbox requires 'topping up' add oil via the filler plug indicated '1' in the photo until it starts to seep from the level plug orifice; replace both plugs securely to complete the task.

Gearbox oil levels must be checked on a fortnightly basis during the season and the oil completely drained and replaced annually.

Draining & Refilling

To drain oil from the gearbox it is necessary to remove the gearbox from the machine. Remove both the filler and the level plugs and invert the gearbox over a suitable container to allow the oil to drain completely. Replace the gearbox on the machine before refilling to the level stated above. *Refer to recommended lubricants page for gearbox oil specifications.*

Gearboxes & Couplings Maintenance – PT240 & PT270 Models

The PT270 machine is equipped with 3 gearboxes, a single central gearbox and two outer gearboxes; these are all housed beneath the top cover of the machine. PT240 machines are also equipped with 3 gearboxes as per above but also feature an additional primary gearbox located on the mainframe.

Access to the gearboxes is by unhooking the two bonnet catches on the front of the cover and tilting it rearwards on its hinges.

Gearboxes Mounting Bolts

Check the mounting nuts and bolts of all gearboxes at the intervals stated in the maintenance schedule and retighten if required.

Locations of the mounting nuts and bolts are indicated in the photos below.



Centre Gearbox Mounting Bolts Location

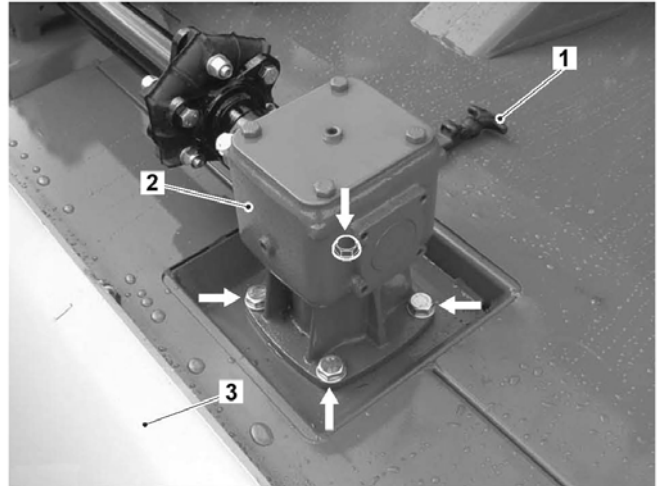

Outer Gearbox Mounting Bolts Location (RH shown)

1) Bonnet Catch 2) Gearbox (RH) 3) Top Cover



Primary Gearbox Mounting Bolts - PT240 Models only

Oil Level

Check the gearboxes oil levels at the intervals stated in the maintenance schedule; ensure the machine is lowered to the ground and located on a firm level site to perform this task. Checking the oil level in the gearboxes is by removal of the Oil Level Plug, indicated '2' in the photos below, the level is correct when the oil is up to the bottom of the level plug orifice. If the gearbox requires 'topping up' add oil via the filler plug indicated '1' in the photos until it starts to seep from the level plug orifice; replace both plugs securely to complete the task.

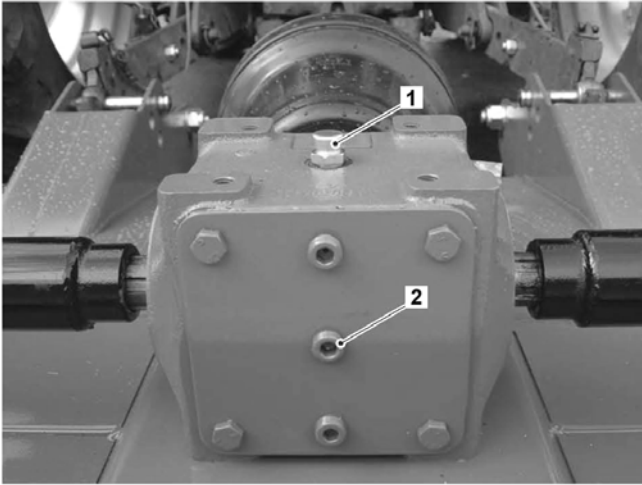

Centre Gearbox Plug Locations
1) Oil Filler Plug 2) Oil Level Plug

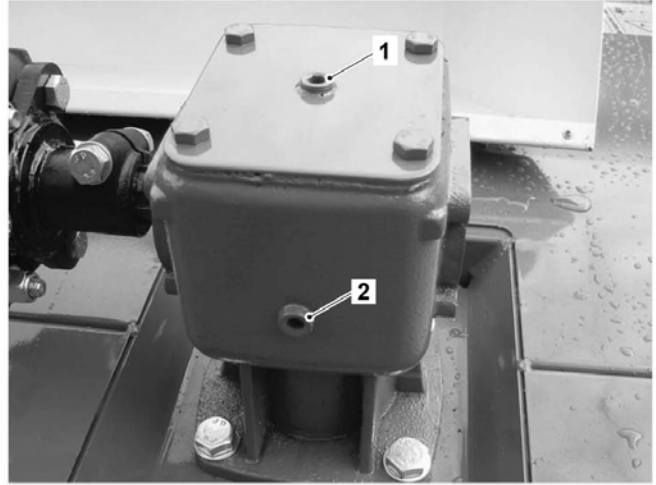

Outer Gearbox Plug Locations (RH shown)
1) Oil Filler Plug 2) Oil Level Plug

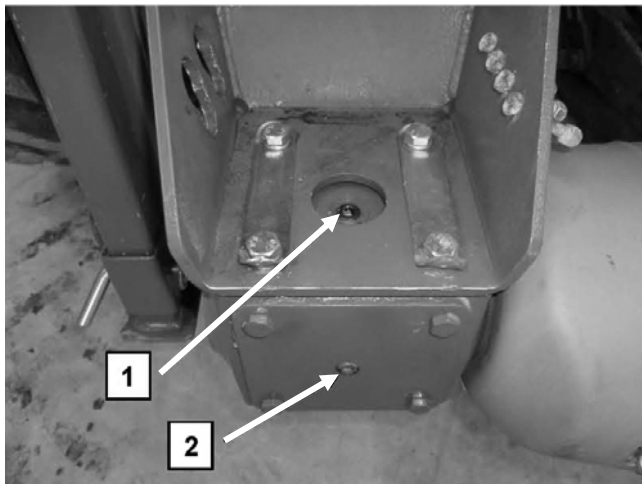

Primary Gearbox Plug Locations (PT240 Model only)
1) Oil Filler Plug 2) Oil Level Plug

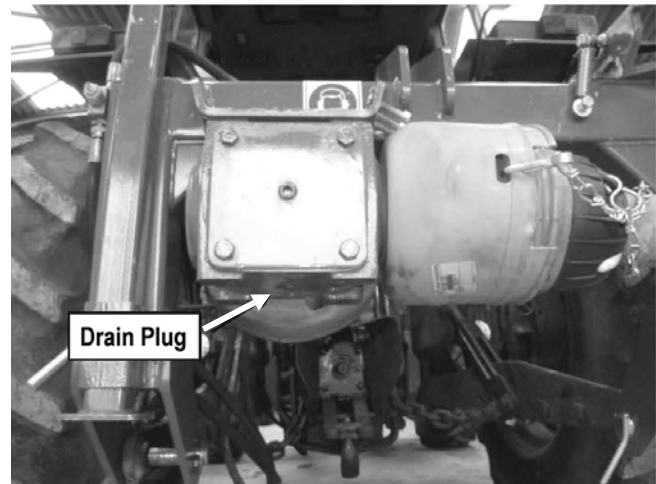

Primary Gearbox Drain Plug (PT240 Model only)

NOTE: The primary gearbox can be drained of oil with the gearbox in situ; it does require removal from the frame.

Gearbox oil levels must be checked on a fortnightly basis during the season and the oil completely drained and replaced annually.

Draining & Refilling

To drain oil from any of the deck mounted gearboxes it is necessary to first remove it from the machine – *refer to removal procedure below.*

With the relevant gearbox off the machine, remove both the filler and the level plugs and invert the gearbox over a suitable container to allow the oil to drain completely. Replace the gearbox on the machine before refilling to the level stated previously. *Refer to recommended lubricants page for gearbox oil specifications.*

The primary gearbox that is fitted to the mainframe on PT240 models can be drained in situ; the machine should be raised and safely supported and a suitable container placed under the gearbox before removing both the oil filler plug and the drain plug and allowing the oil to drain. Replace the oil to the correct level using the same method as described for previous gearboxes.

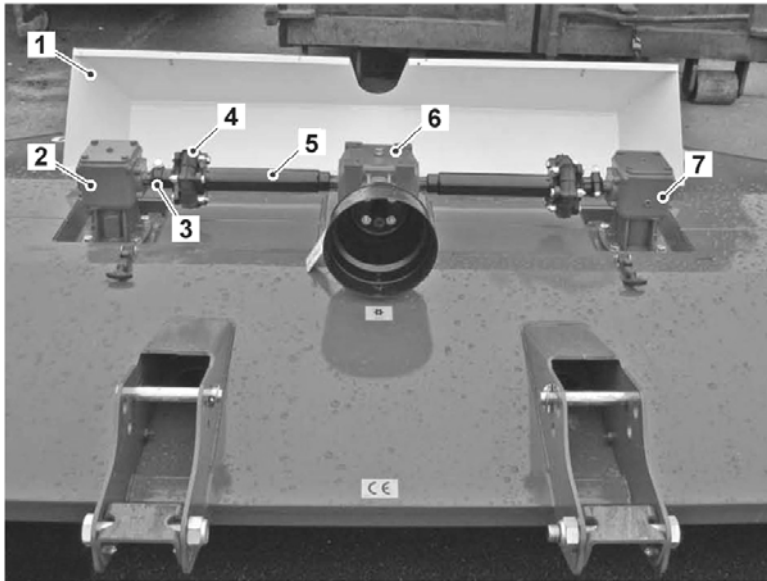

- 1) Top Cover
- 2) RH Outer Gearbox
- 3) Short Driveshaft Clamping Bolt
- 4) Flexible Coupling
- 5) Long Driveshaft
- 6) Centre Gearbox
- 7) LH Outer Gearbox

Gearboxes Removal Procedure

- Remove the six flexible coupling mounting bolts.
- Remove the relevant short driveshaft clamping bolt.
- Slide the long driveshaft towards the central gearbox.
- Slide the short driveshaft towards the relevant outer gearbox.
- Remove the flexible coupling and both driveshafts and store them safely.
- Lift and support the machine on safety supports.
- With assistance, support the blade carrier, remove the split pin and rotor castle nut and remove the rotor from the splined gearbox output shaft - *refer to the illustration on the 'Blade Carrier' page of this maintenance section.*
- With assistance, remove the four nuts and mounting bolts securing the gearbox to the machine.
- Carefully remove the gearbox.

Gearboxes Replacement

Replacement of the gearboxes is a reversal of the removal procedure – *ensure mounting bolts and castle nuts are tightened as specified in the 'Specific Torque Settings' chart.*

Flexible Couplings

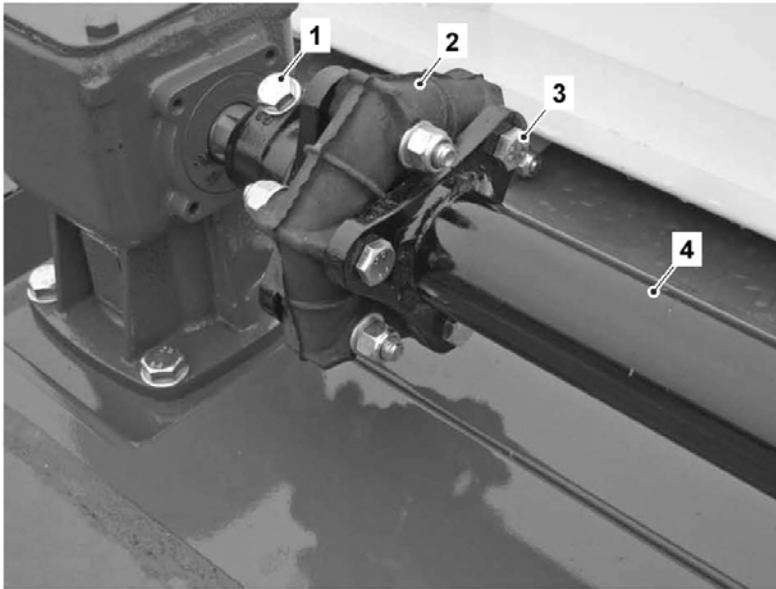

- 1) Short driveshaft clamp bolt (2 off)
- 2) Flexible coupling (2 off)
- 3) Flexible coupling mounting bolts (12 off)
- 4) Long driveshaft (2 off)

Check each flexible coupling for damage and cracks. Replace if any damage is found. Check the tightness of the short driveshaft clamping bolt and coupling mounting bolts to the correct torque. Repeat with the other drive coupling. *Refer to 'Specific Torque Settings' chart.*



WARNING: Ensure that the opposing blade carriers and blades are at 90° to each other after any maintenance that requires removing or replacing drive couplings.

Blade Carrier & Blade Maintenance



WARNING: Ensure that the machine is safely supported using suitable lifting and support equipment before attempting to work beneath a machine – never use or rely on the tractor's hydraulic system to support the machine.

Blade Carrier Removal

- Lift and support the machine on safety supports.
- With assistance, support the blade carrier, remove the split pin and rotor castle nut and remove the rotor from the splined gearbox output shaft. *Refer to photo below.*
- With assistance, remove the four nuts and mounting bolts securing the gearbox to the machine.
- Remove the gearbox.

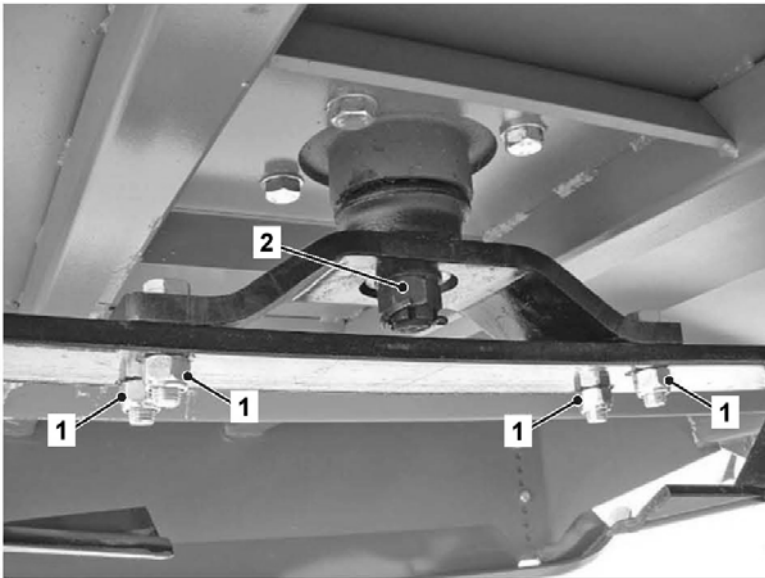

- 1) Blade Carrier mounting bolts and nuts
- 2) Rotor hub castle nut

Blade Carrier Replacement

Replacement is the reverse of removal procedure stated above - *tighten the mounting bolts and castle nut as specified in 'Specific Torque Settings' chart.*

Blade Carrier Maintenance

Check the rotor hub for slack. Some settlement may occur after the first hours of working. Re-tighten the castle nut one quarter of a turn at a time, and back off until the split pin can be fitted. Repeat until the slackness is removed. Check the blade carrier mounting bolts for tightness - *Refer to 'Specific Torque Settings' chart.*

Blades & Bushes

The cutting blades are mounted in hardened bushes and are free-swinging to reduce shock load and damage to the transmission.

Blades and blade bushes should be inspected for wear/damage the intervals stated in the maintenance schedule.

Replace blades that are bent, excessively nicked, damaged, or when they are worn beyond the shape of their original profile. Always replace blades immediately when their level of wear or damage causes rotor vibration; continued use of the machine in this condition could cause damage to gearbox and/or drive components. Blades must always be replaced in opposing pairs to retain rotor balance.

Replace bushes and blade fixings immediately should excessive signs of wear or damage be detected.

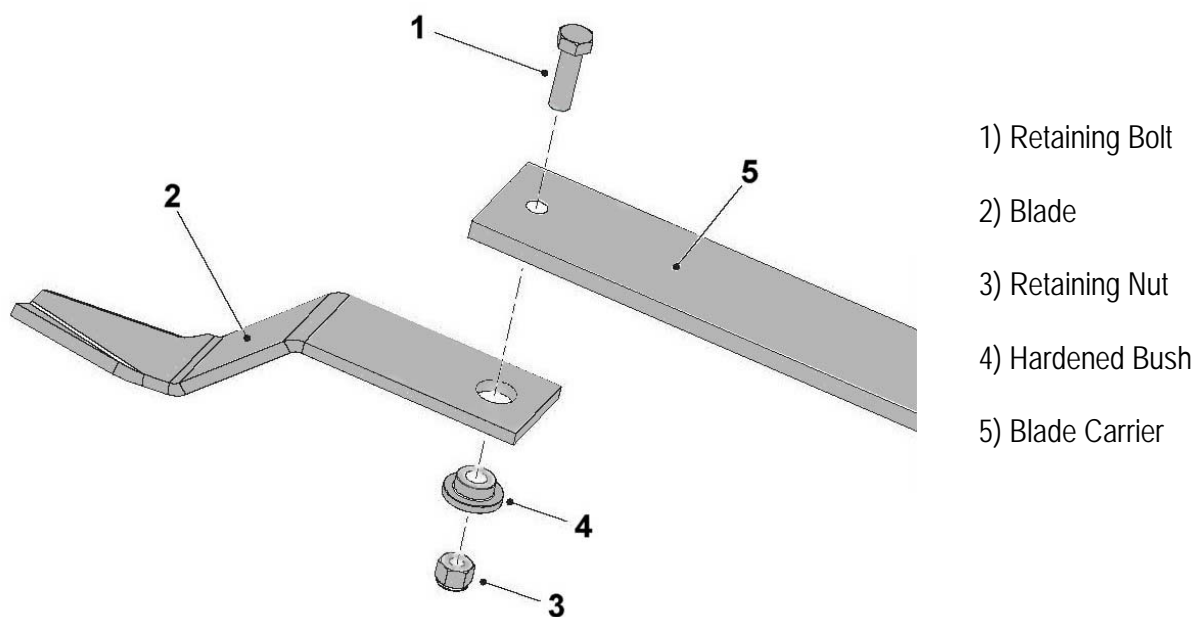

WARNING: Ensure that the machine is safely supported using suitable lifting and support equipment before attempting to work beneath a machine – never use or rely on the tractor's hydraulic system to support the machine.

Blade & Blade Bush Removal

Remove the retaining bolt and nut and dismantle the blade and bush.

Blade and/or Blade Bush Replacement

Replace the blade and/or the bush and reassemble to the carrier with a new nut and bolt. *Tighten the retaining bolt and nut bolt as specified in 'Specific Torque Settings' chart.*

NOTE: On Twin Rotor machines the cutting blades on the left and right blade carriers are not interchangeable.

LUBRICANTS

Recommended Lubricants

Supplier	Gearbox(es)	Grease Nipples	Roller Chains
BP	Energear Hypo 80W-90 EP	Energrease L2M	Penetrating oil
Castrol	Multitrax 80W/140 EPX 80W/90 EPX 85W/140	Castrol MS 3 Castrol APS 2	Chain grease
STAT Oil	Gearway G4 80W-90	MP Grease (Moly)	Super oil for chain saws
Q8	Q 8 T 55 80W/90	Q 8 Rembrandt Moly S2	Q 8 Giotto/Q 8 Wagner 220
Mobil Oil	Mobilube HD 80W/90	Mobilgrease Special	Mobilvactra No. 2
Shell	Spirax HD 80W/90	Retinax A	Malleus HDX
Texaco	Geartex EP-C 9-W/90	Molytex 2 Molytex EP 2	Way Lubricant
OK	OK Gearoil GL 5 80W/90	OK Molygrease	OK Compound 2
Hydro	Hypoid Gearoil 80W/90	Moly D Grease	Moly chain wheel grease

TORQUE SETTINGS

PT180 MODELS Specific Torque Settings ▼

Fastener	Torque Setting (Nm)
PTO Shaft Shearbolt	26
Gearbox Mounting Bolts	225
Blade Carrier Bolts	225
Cutting Blade Bolts	225
Rotor Hub Castle Nut	<i>Refer to blade carrier page</i>

PT240 & PT270 MODELS Specific Torque Settings ▼

Fastener	Torque Setting (Nm)
PTO Shaft Shearbolt	26
Outer Gearbox Mounting Bolts	225
Centre Gearbox Mounting Bolts	90
Flexible Coupling Bolts	90
Blade Carrier Bolts	225
Cutting Blade Bolts	225
Rotor Hub Castle Nut	<i>Refer to blade carrier page</i>

General Torque Settings ▼

Thread Diameter	Nm +10% -0
5mm	6
6mm	10
8mm	26
10mm	52
12mm	90
14mm	144
16mm	225
20mm	436
22mm	594

TROUBLESHOOTING GUIDE

The charts below are intended to help in diagnosing and rectifying any problems with your machine. If the problem persists, please consult your supplier or contact your local dealer for advice.

Troubleshooting Chart - PT180 Machines

Fault	Possible Cause	Remedy
Shear bolt failure on start up	Tractor revs too high	Reduce revs to idle before engaging PTO
Shear bolt failure on start up	Incorrect shear bolt	Check the shear bolt is the correct grade and size
Shear-bolt failure in operation	Obstacle encountered	Inspect ground for stones, stumps, etc. before replacing with the correct grade of bolt
Excessive vibration	Broken or missing blade	Check blades and replace with new if necessary
Uneven stubble	Travelling too fast	Reduce forward speed
Ragged stubble	Blunt blades	Replace blades
Scalping ground	Skids set too low	Reset skid height
Excessive ground marking	Topper not following ground contours correctly	Check transport strap and adjust top link if necessary
Uncut material	Heavy crop	Reduce forward speed, or cut twice

Troubleshooting Chart - PT240 & PT270 Machines

Fault	Possible Cause	Remedy
Shear bolt failure on start up	Tractor revs too high	Reduce revs to idle before engaging PTO
Shear bolt failure on start up	Incorrect shear bolt	Check the shear bolt is the correct grade and size
Shear-bolt failure in operation	Obstacle encountered	Inspect ground for stones, stumps, etc. before replacing with the correct grade of bolt
Excessive vibration	Broken or missing blade	Check blades and replace with new if necessary
Excessive vibration	Cracked or damaged flexible coupling	Check couplings and replace with new if necessary
Clashing blades	Incorrect blade timing	Check the blade timing is 90° out of phase and correct if necessary
Uneven stubble	Travelling too fast	Reduce forward speed
Ragged stubble	Blunt blades	Replace blades
Scalping ground	Skids set too low	Reset skid height
Excessive ground marking	Topper not following ground contours correctly	Check transport strap and adjust top link if necessary
Uncut material	Heavy crop	Reduce forward speed, or cut twice

PARTS MANUAL
PT180 / 240 / 270
PASTURE TOPPERS

Module(s): 1096501

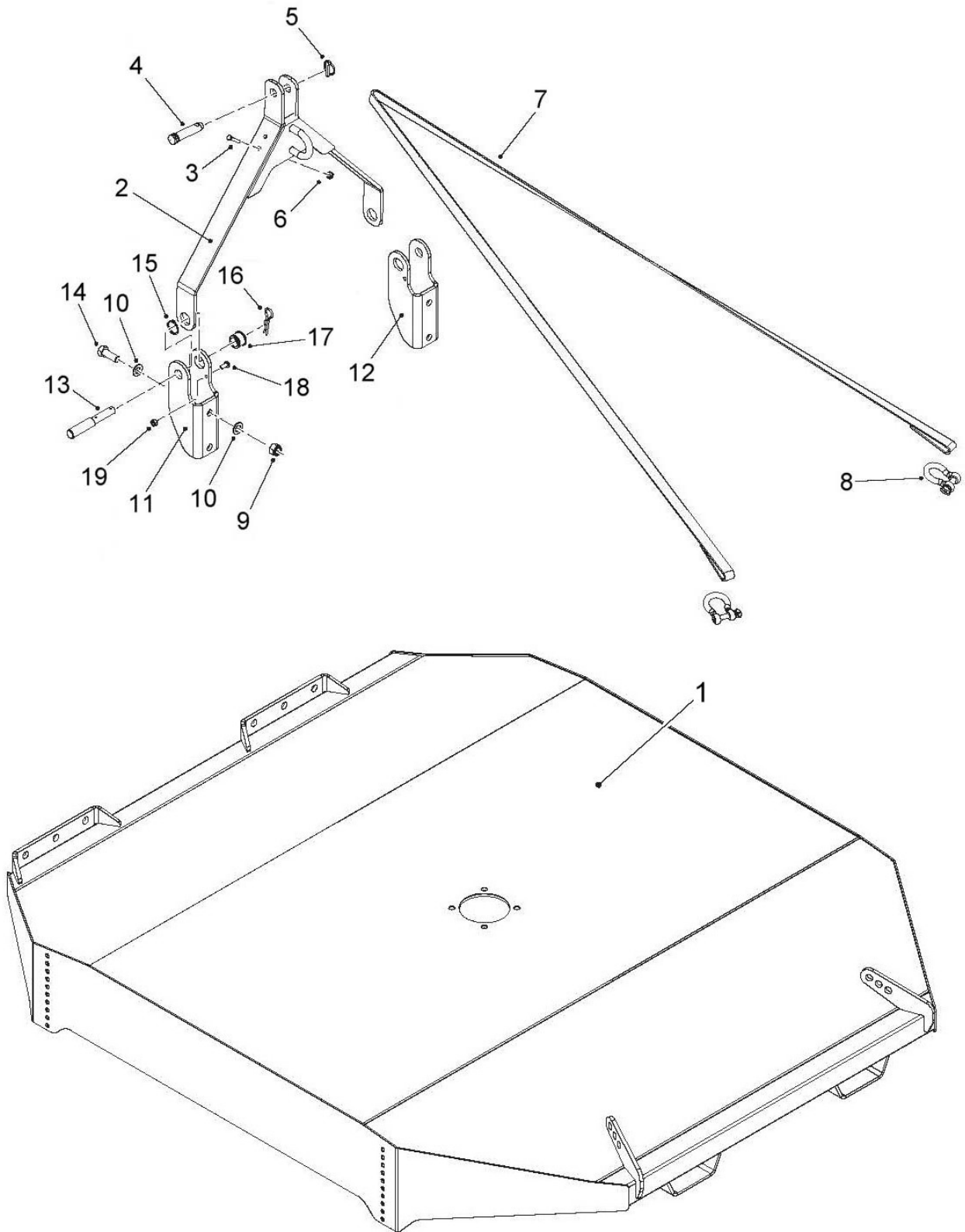

Module(s): 1096501

REF.	QTY.	PART No.	DESCRIPTION
		1096501	DECK MODULE - PT180
1	1	1096401	DECK
2	1	1096421	'A' FRAME / HEADSTOCK
3	4	9213104	BOLT
4	1	1096422	LINKAGE PIN (TOP)
5	1	0431217	LINCH PIN
6	4	9163004	NYLOC NUT
7	1	1096423	LIFTING STRAP
8	2	1096424	BOW SHACKLE
9	4	9163008	NYLOC NUT
10	8	1096425	WASHER
11	1	1096426	LINKAGE BRACKET - LEFT
12	1	1096427	LINKAGE BRACKET - RIGHT
13	2	1096428	LINKAGE PIN (LOWER)
14	4	9313118	SETSCREW
15	2	1096429	CIRCLIP
16	2	1096430	'R' CLIP
17	2	1096431	PIVOT BOSS
18	2	9313055	SETSCREW
19	1	9163005	NYLOC NUT

Module(s): 1096517

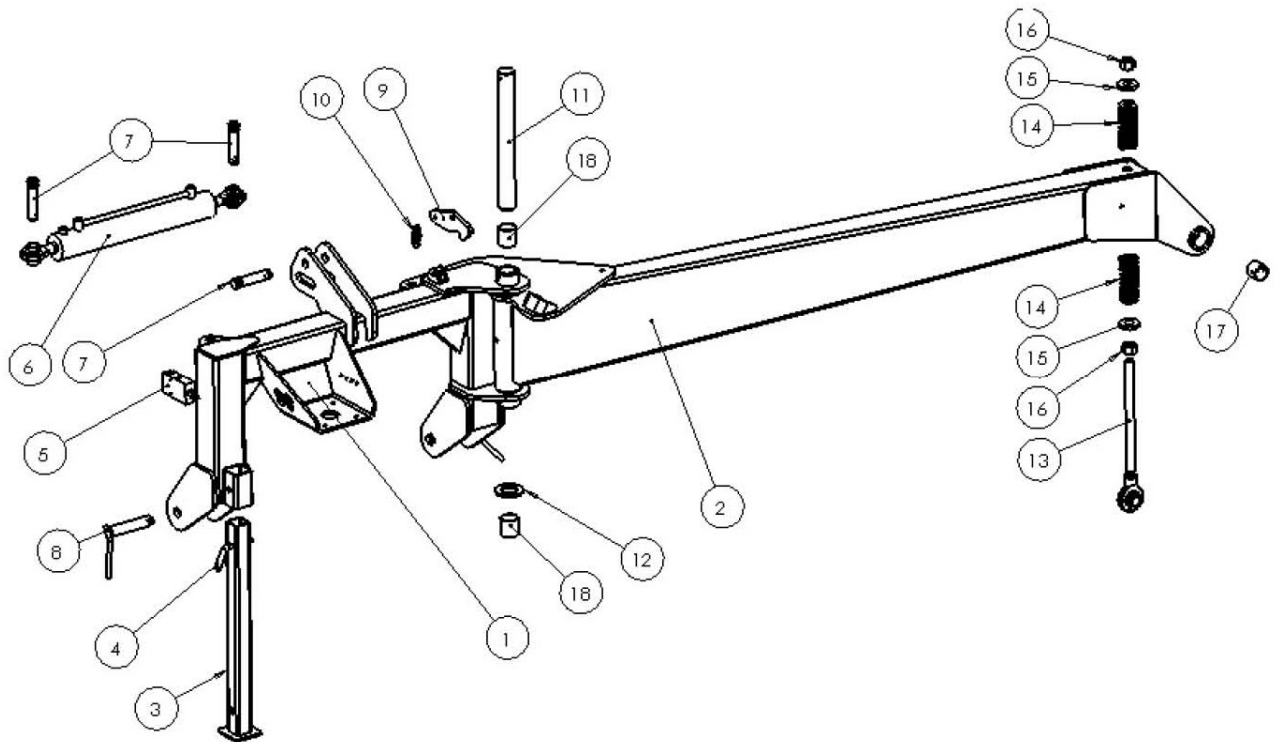

REF.	QTY.	PART No.	DESCRIPTION
		1096517	FRAME & ARM MODULE - PT240
1	1	1096460	HITCH FRAME
2	1	1096462	SIDE ARM
3	1	1096464	PARKING LEG
4	1	1096466	LEG PIN
5	1	1096467	BREAKBACK VALVE
6	1	1096468	SLEW RAM
7	3	1096422	TOP LINK PIN
8	2	1096436	LOWER LINK PIN
9	1	1096470	SAFETY LATCH
10	1	1096472	LATCH SPRING
11	1	1096473	ARM PIVOT PIN
12	1	1096474	PIVOT THRUST WASHER
13	1	1096475	ADJUSTER STRUT
14	2	1096476	ADJUSTER SPRING
15	2	1096477	ADJUSTER WASHER
16	4	1096478	ADJUSTER NUT
17	2	1096479	DECK PIVOT BUSH
18	2	1096480	ARM PIVOT BUSH

Module(s): 1096519, 1096521

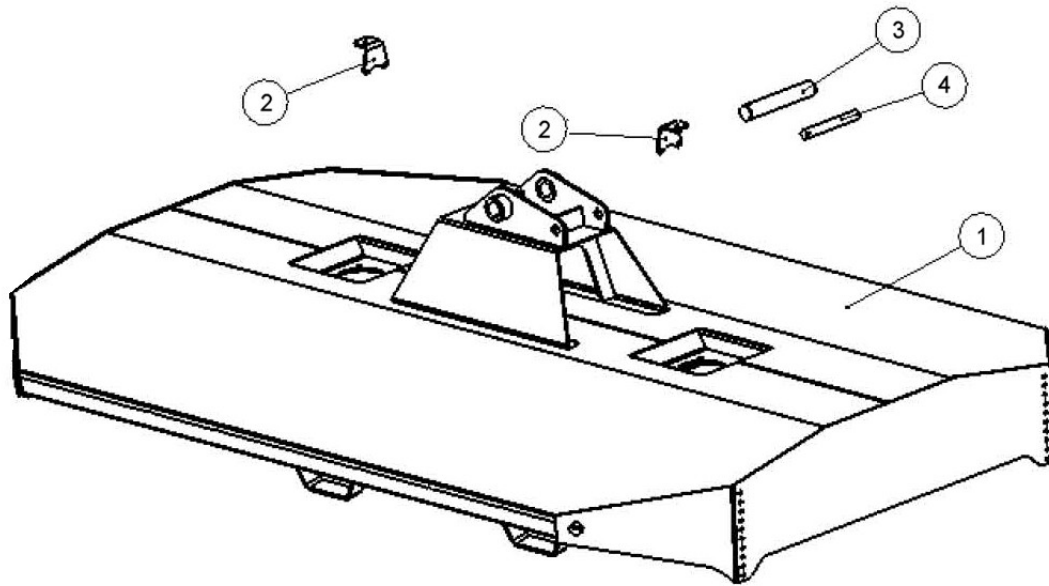

REF.	QTY.	PART No.	DESCRIPTION
		1096519	DECK MODULE - PT240
1	1	1096453	DECK
2	2	1096457	COVER SUPPORT BRACKET
3	1	1096458	DECK PIVOT PIN
4	1	1096459	SUSPENSION PIVOT PIN

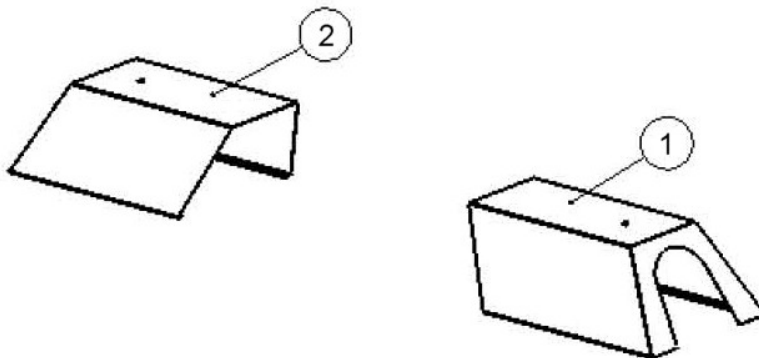

REF.	QTY.	PART No.	DESCRIPTION
		1096521	COVERS MODULE - PT240
1	1	1096455	COVER - LEFT
2	1	1096456	COVER - RIGHT

Module(s): 1096502

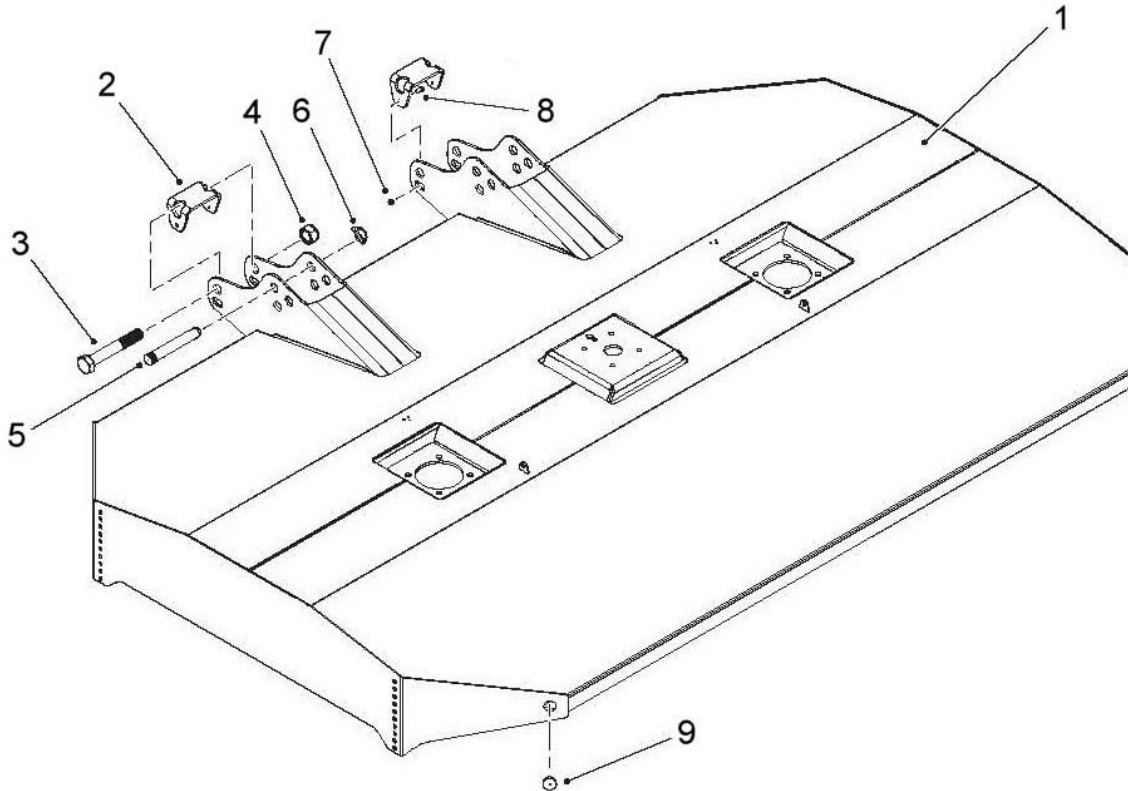

REF.	QTY.	PART No.	DESCRIPTION
		1096502	DECK MODULE - PT270
1	1	1096402	DECK
2	2	1096434	LIFT ARM BRACKET
3	2	1096435	BOLT
4	2	2770427	NYLOC NUT
5	2	1096436	LOWER LINK PIN
6	2	0431217	LINCH PIN
7	4	9313044	SETSCREW
8	4	9163004	NYLOC NUT
9	4	1096437	PLUG

Module(s): 1096503

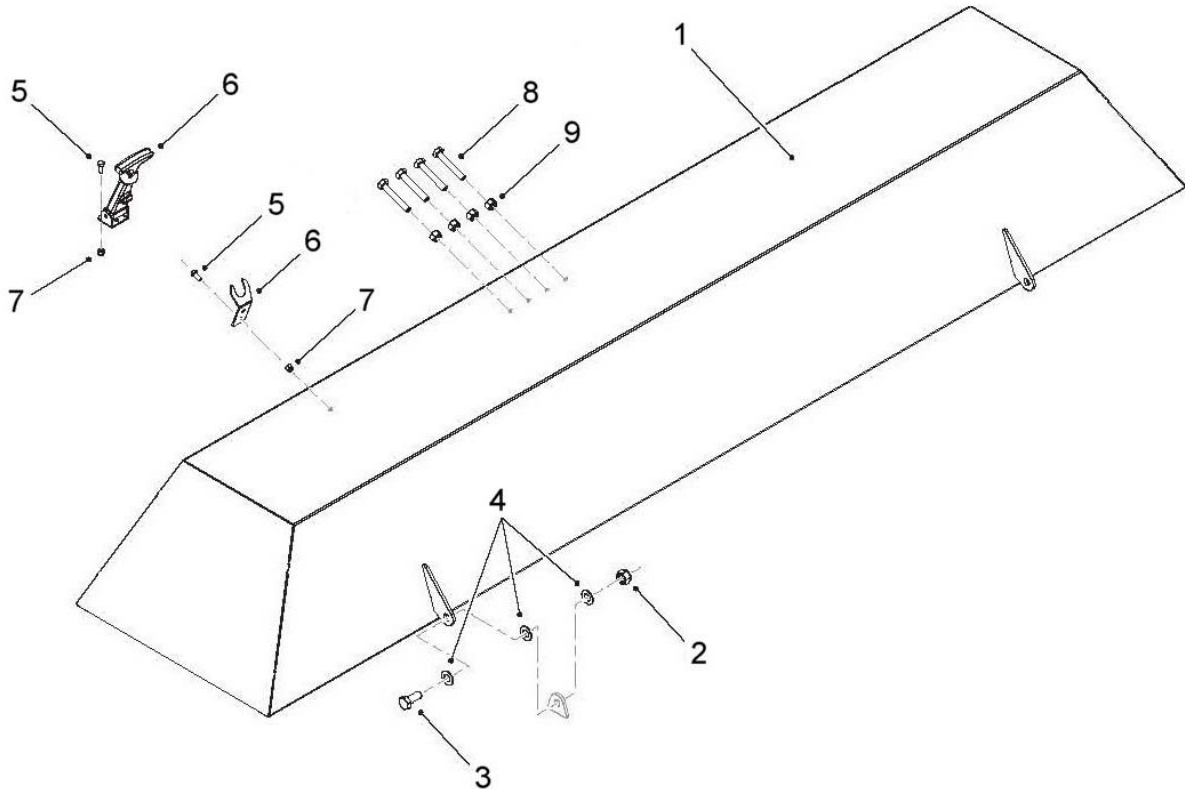

REF.	QTY.	PART No.	DESCRIPTION
		1096503	COVER MODULE - PT270
1	1	1096438	TOP COVER
2	2	9163005	NYLOC NUT
3	2	9313055	SETSCREW
4	6	1096439	WASHER
5	10	9313022	SETSCREW
6	2	1096440	BONNET CATCH
7	10	05.287.09	NYLOC NUT
8	4	1096432	BOLT
9	4	9163004	NYLOC NUT

Module(s): 1096515

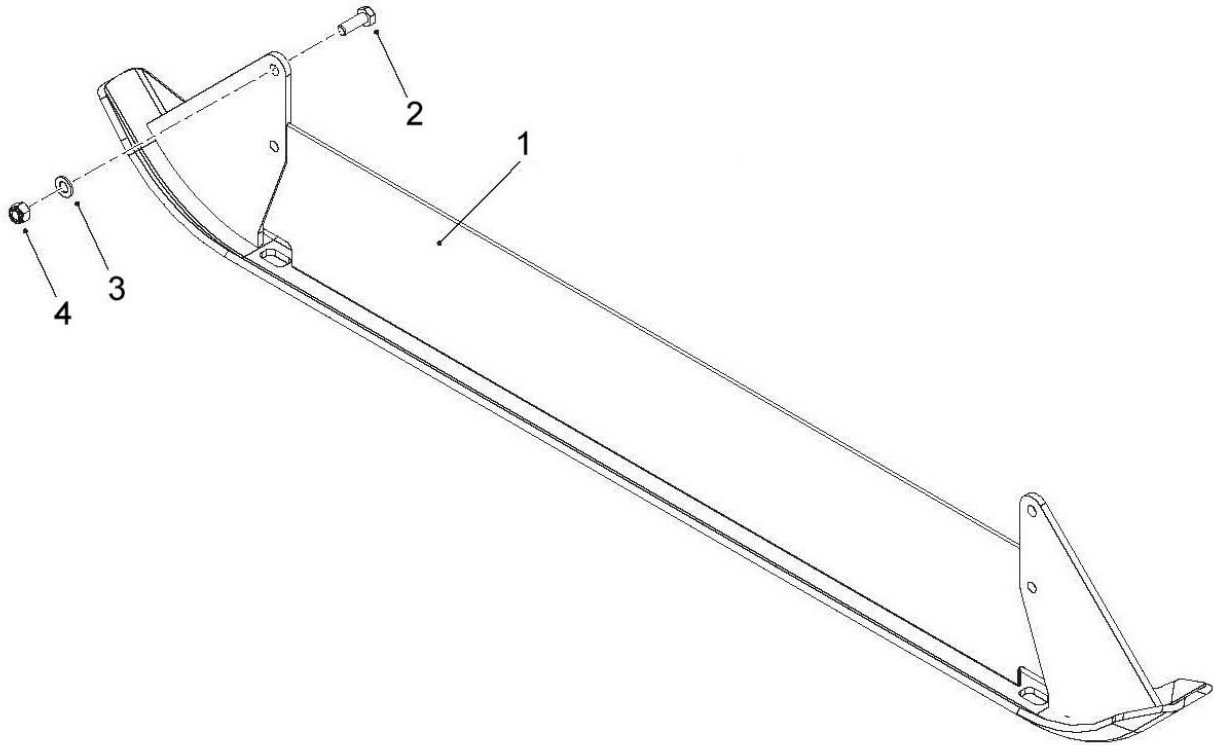

REF.	QTY.	PART No.	DESCRIPTION
		1096515	SKIDS MODULE - PT180
1	2	1096418	SKID
2	8	9300122	SETSCREW
3	8	1096420	WASHER
4	8	9163006	NYLOC NUT

Module(s): 1096516

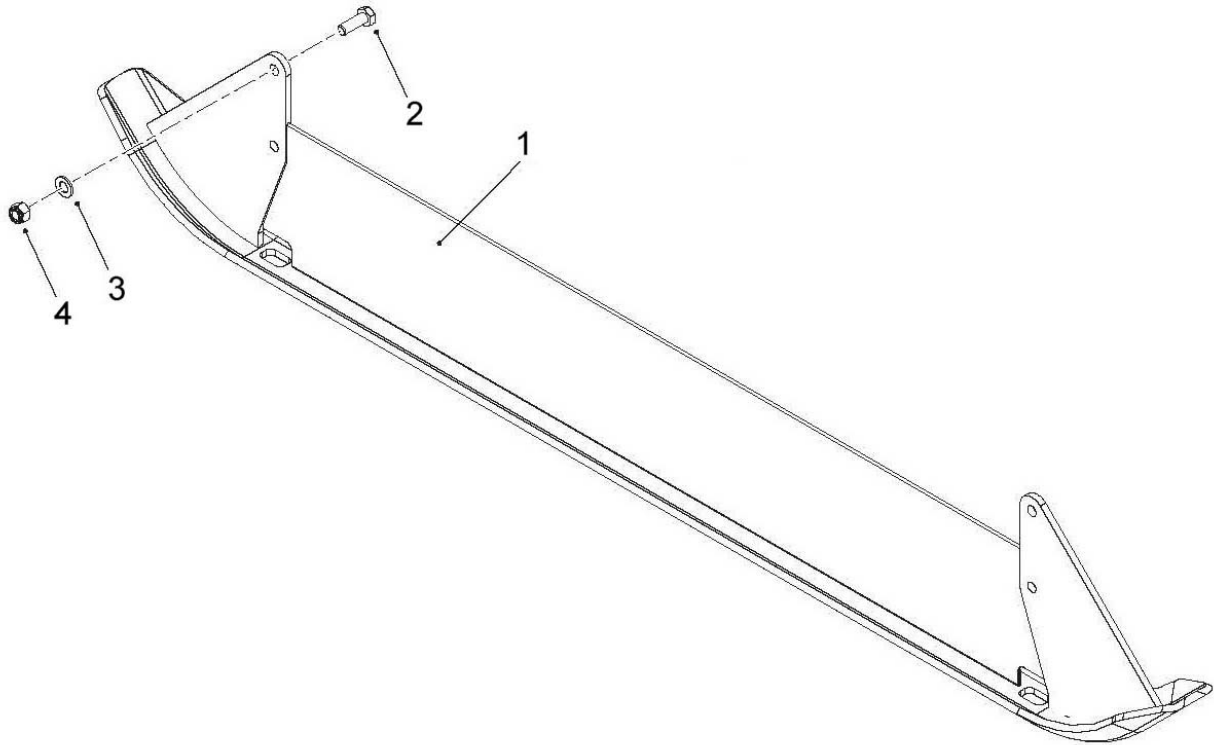

REF.	QTY.	PART No.	DESCRIPTION
		1096516	SKIDS MODULE - PT240 & PT270
1	2	1096419	SKID
2	8	9300122	SETSCREW
3	8	1096420	WASHER
4	8	9163006	NYLOC NUT

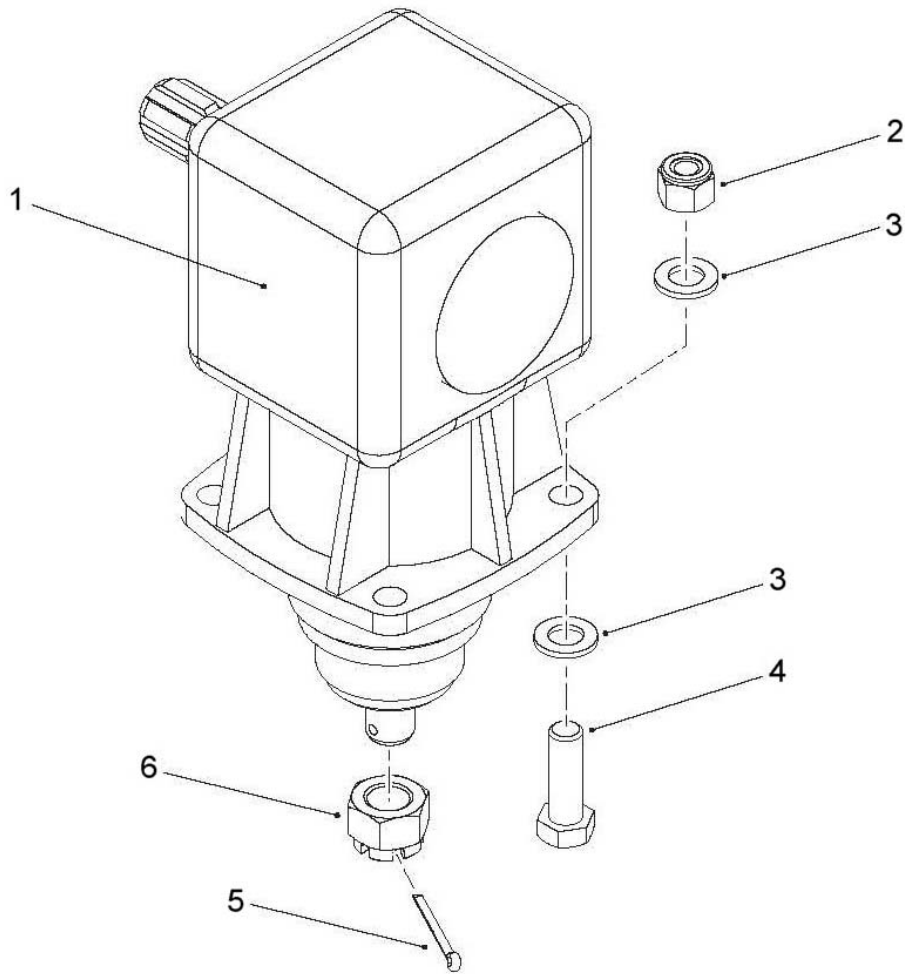

REF.	QTY.	PART No.	DESCRIPTION
		1096507	DRIVE MODULE - PT180
1	1	1096403	GEARBOX
2	4	9163007	NYLOC NUT
3	8	1096404	WASHER
4	4	9213107	BOLT
5	1	1096405	SPLIT PIN
6	1	1096406	CASTLE NUT

Module(s): 1096509

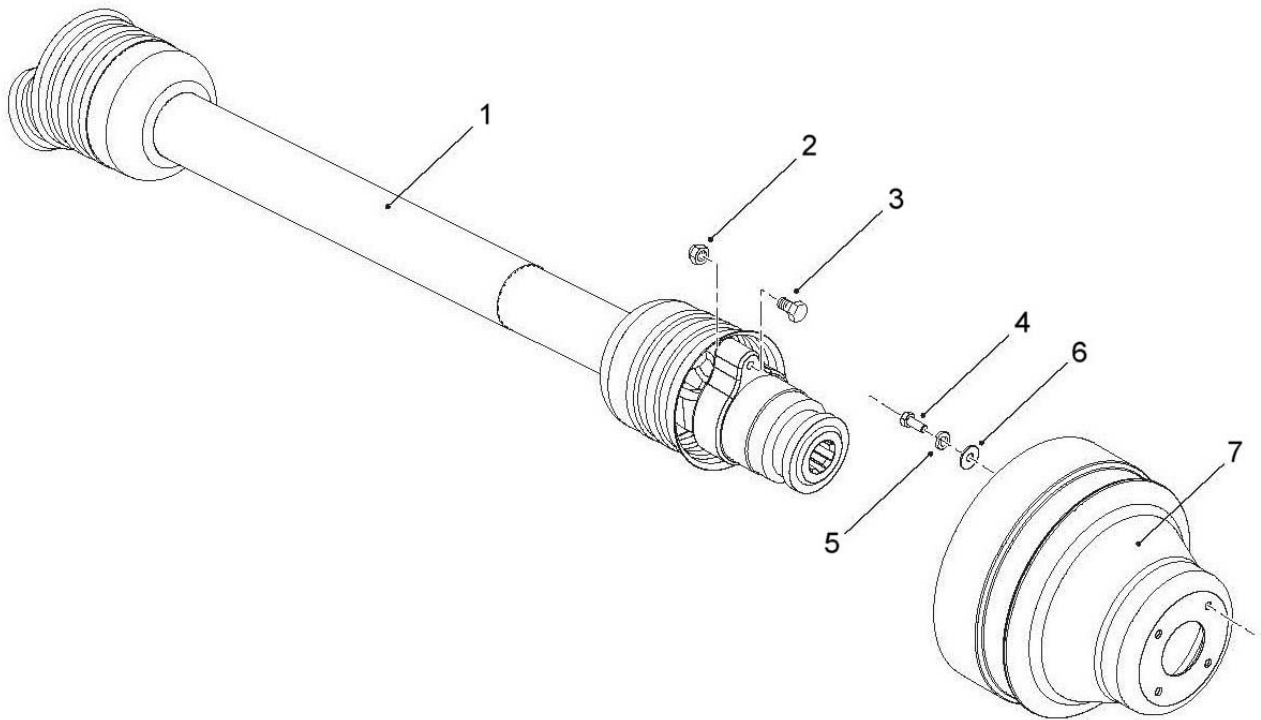

REF.	QTY.	PART No.	DESCRIPTION
		1096509	PTO MODULE - PT180
1	1	T7063	PTO SHAFT c/w SHEAR BOLT 1096407
2	1	9163004	NYLOC NUT
3	1	1096407	SHEAR BOLT
4	4	9313044	SETSCREW
5	4	9100204	SPRING WASHER
6	4	1096408	WASHER
7	1	1096409	PTO CONE

Module(s): 1096522

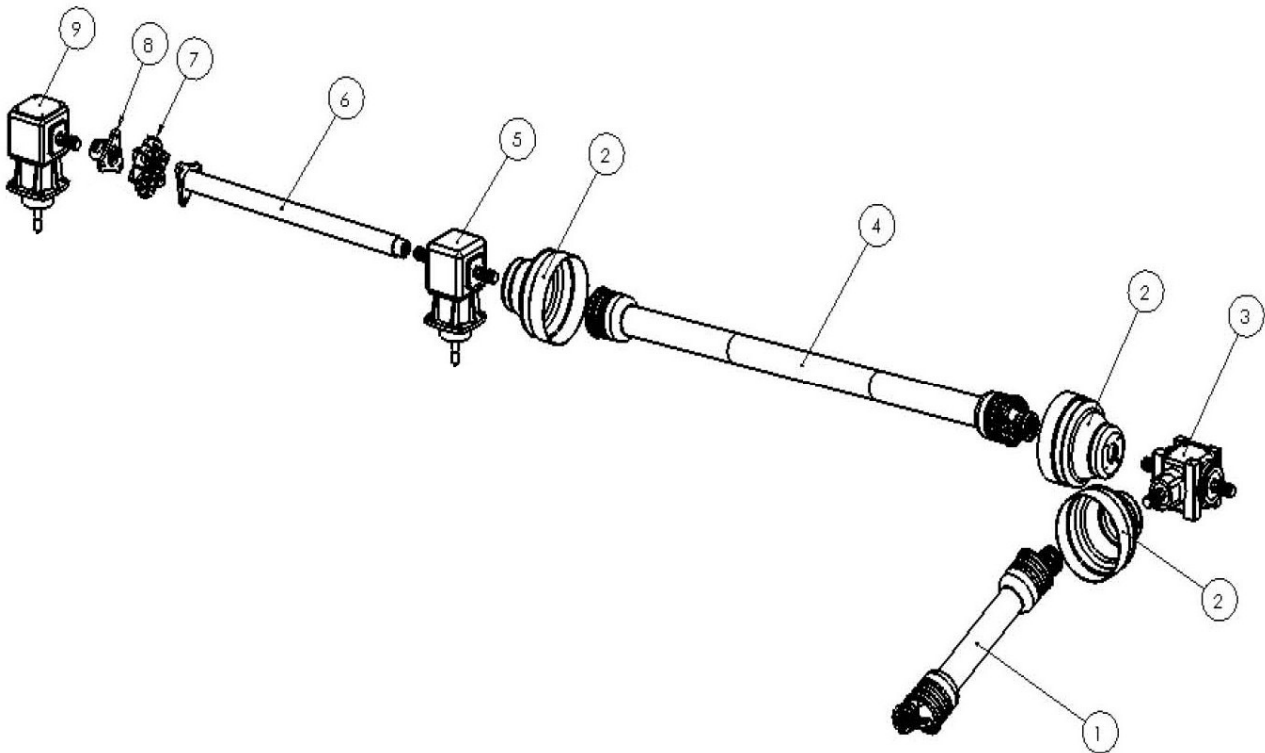

REF.	QTY.	PART No.	DESCRIPTION
		1096522	PTO & DRIVE MODULE - PT240
1	1	1096481	PRIMARY PTO SHAFT
	1	1096432	<i>Shear Bolt for PTO Shaft 1096481</i>
2	3	1096409	PTO GUARD CONE
3	1	1096441	GEARBOX
4	1	1096482	SECONDARY PTO SHAFT
5	1	1096483	GEARBOX (TWIN SHAFT)
6	1	1096484	DRIVE SHAFT
7	1	1096445	FLEXIBLE COUPLING
8	1	1096444	DRIVE SHAFT (SHORT)
9	1	21459.02	GEARBOX (SINGLE SHAFT)

Module(s): 1096508

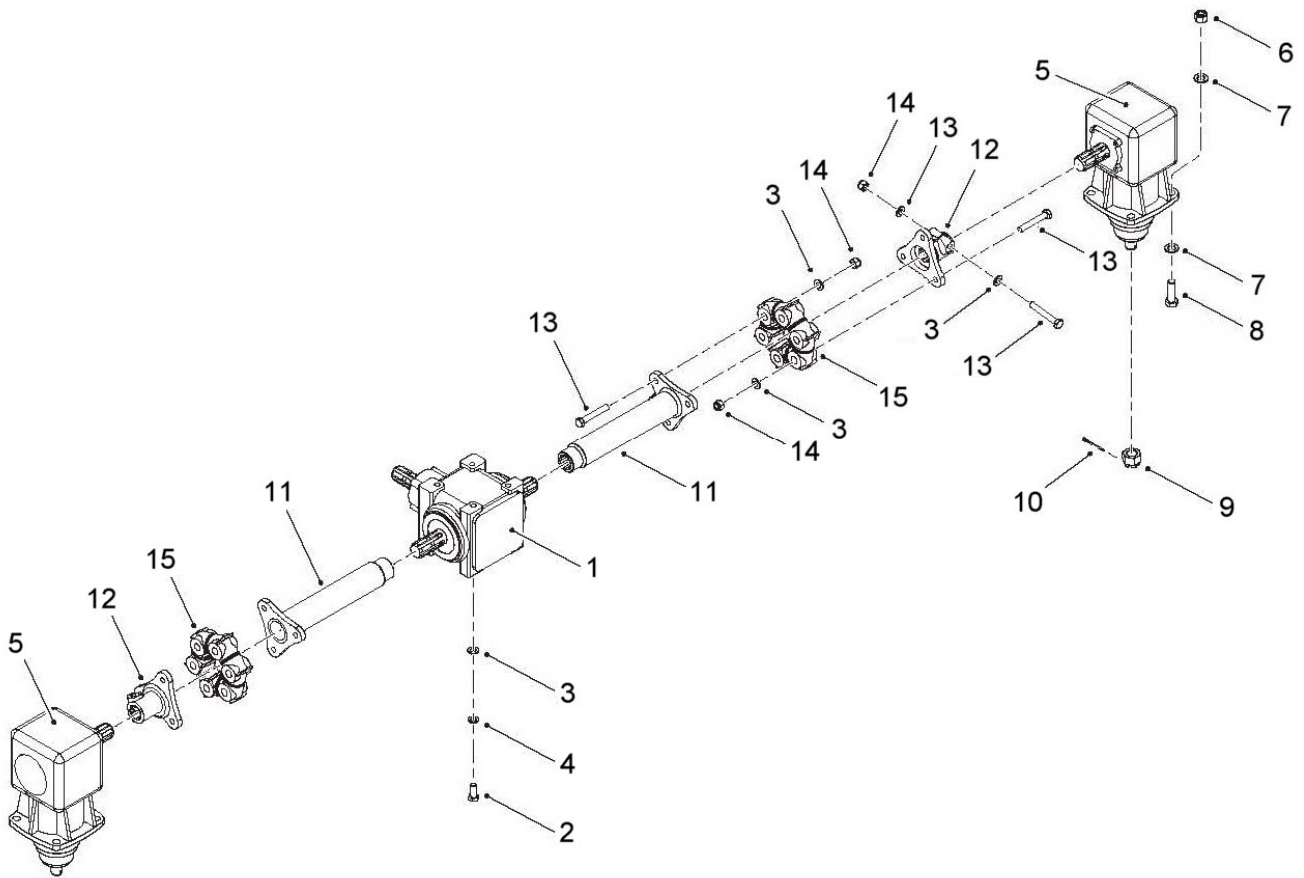

REF.	QTY.	PART No.	DESCRIPTION
		1096508	DRIVE MODULE - PT270
1	1	1096441	GEARBOX (CENTRE)
2	4	9313066	SETSCREW
3	20	1096420	WASHER
4	4	9100206	SPRING WASHER
5	2	21459.02	GEARBOX (OUTER)
6	8	9163007	NYLOC NUT
7	8	1096404	WASHER
8	8	9200025	BOLT
9	2	1096406	CASTLE NUT
10	2	1096405	SPLIT PIN
11	2	1096443	DRIVE SHAFT (LONG)
12	2	1096444	DRIVE SHAFT (SHORT)
13	14	9213166	BOLT
14	14	9163006	NYLOC NUT
15	2	1096445	FLEXIBLE COUPLING

Module(s): 1096510

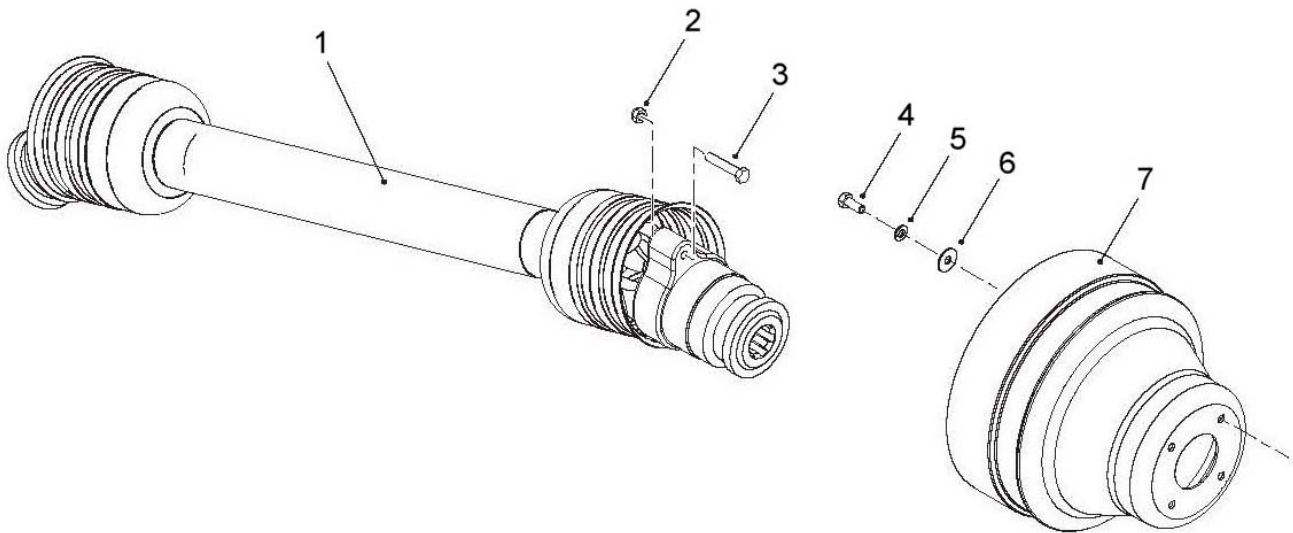

REF.	QTY.	PART No.	DESCRIPTION
		1096510	PTO MODULE - PT270
1	1	21040.03	PTO SHAFT c/w SHEAR BOLT 1096432
2	1	9163004	NYLOC NUT
3	1	1096432	SHEAR BOLT
4	4	9313044	SETSCREW
5	4	9100204	SPRING WASHER
6	4	1096408	WASHER
7	1	1096409	PTO CONE

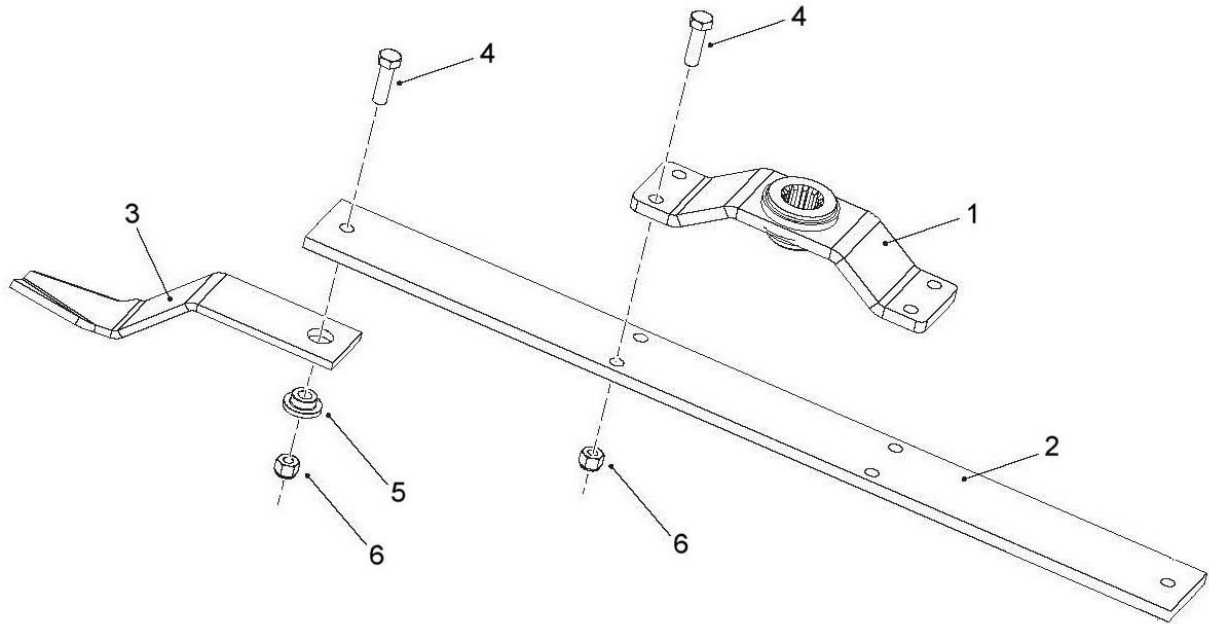

REF.	QTY.	PART No.	DESCRIPTION
		1096505	ROTOR MODULE - PT180
1	1	1096411	ROTOR HUB
2	1	1096412	BLADE CARRIER
3	2	1096415	BLADE
4	6	1096410	BOLT
5	2	1096414	PIVOT BUSH
6	6	1096413	LOCKNUT

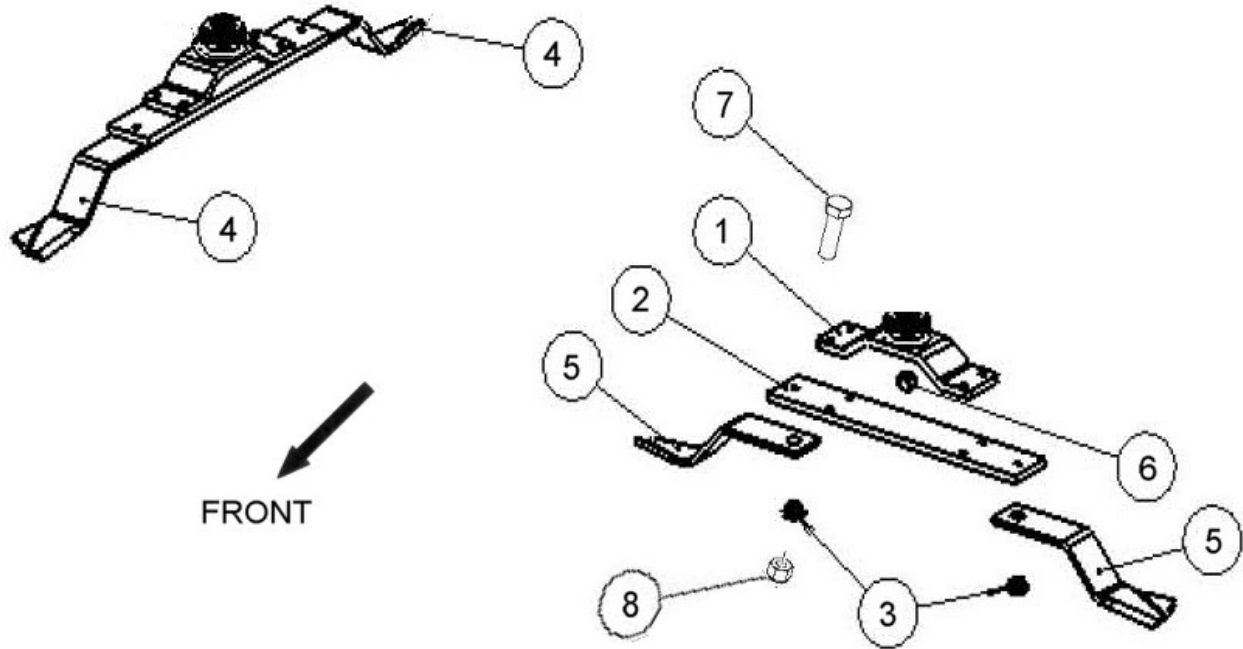

REF.	QTY.	PART No.	DESCRIPTION
		1096504	ROTOR MODULE - PT240
1	2	1096411	ROTOR HUB
2	2	1096485	BLADE CARRIER
3	4	1096414	BLADE PIVOT BUSH
4	2	1096416	BLADE (LH)
5	2	1096415	BLADE (RH)
6	2	1096406	CASTLE NUT
7	4	1096410	BLADE BOLT
8	4	1096413	LOCKNUT

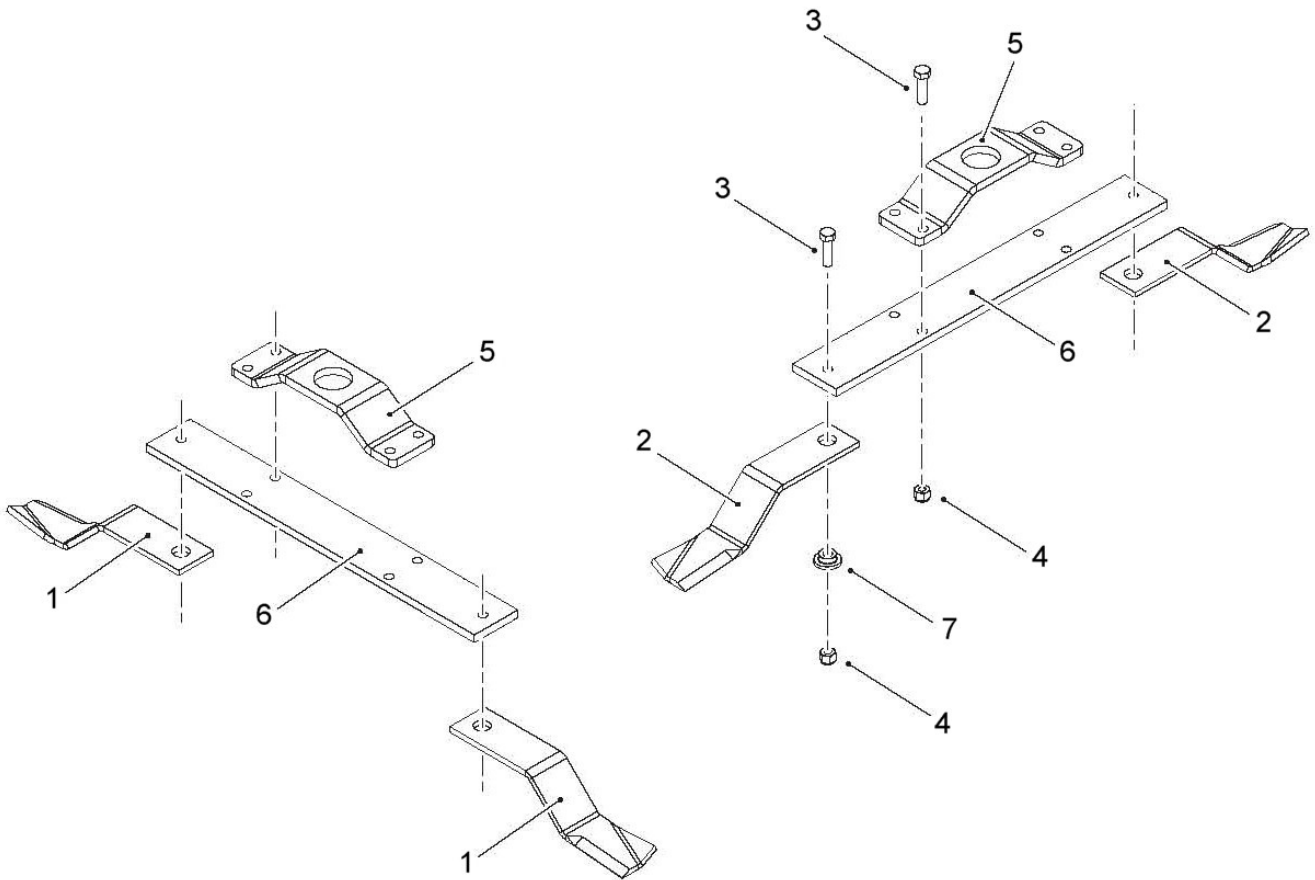

REF.	QTY.	PART No.	DESCRIPTION
		1096506	ROTOR MODULE - PT270
1	2	1096415	BLADE (RH)
2	2	1096416	BLADE (LH)
3	12	1096410	BOLT
4	12	1096413	NYLOC NUT
5	2	1096411	ROTOR HUB
6	2	1096417	BLADE CARRIER
7	4	1096414	PIVOT BUSH

Module(s): 1096511

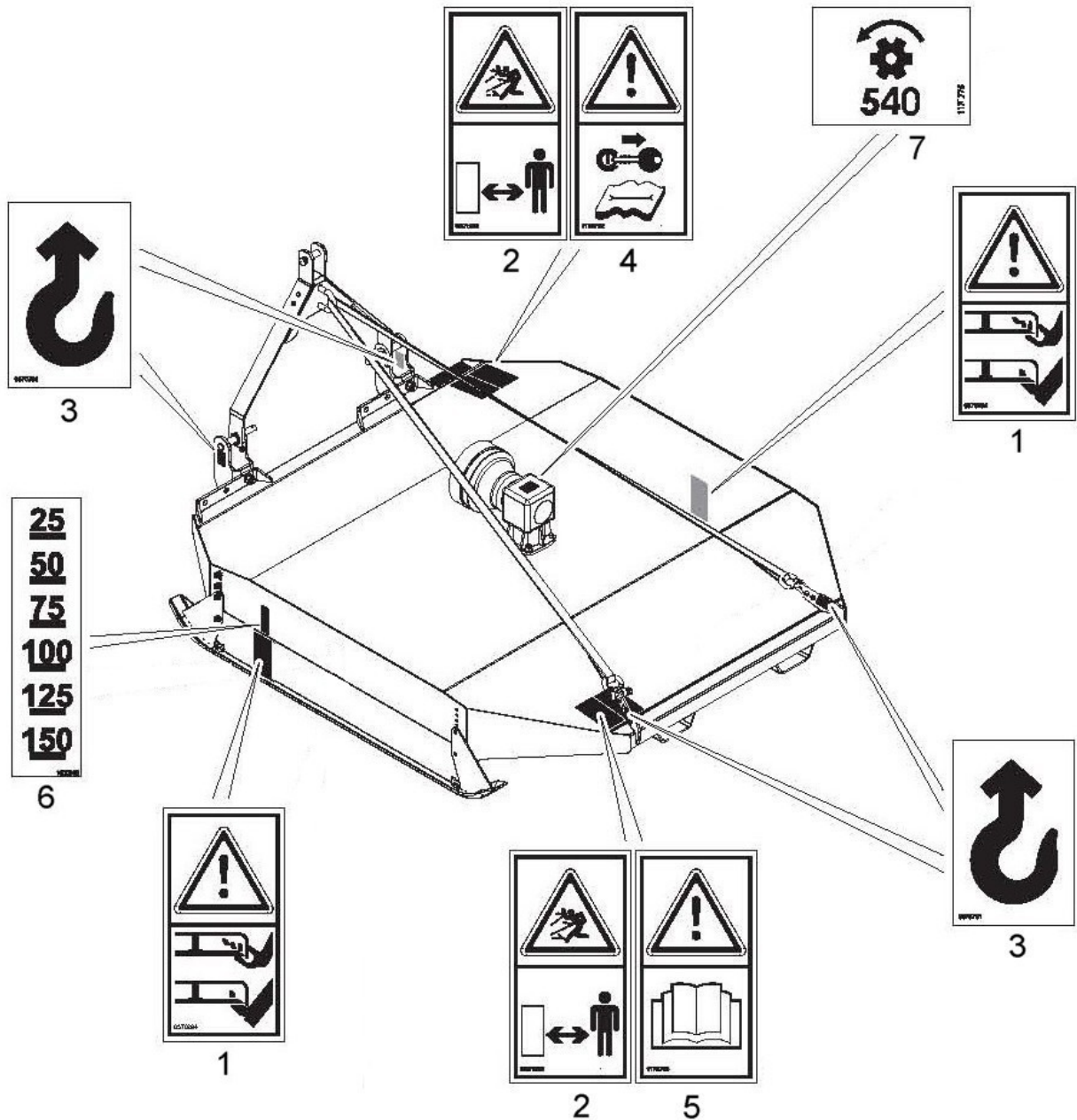

REF.	QTY.	PART No.	DESCRIPTION
		1096511	BASIC DECAL KIT - PT180
1	2	09.821.19	DECAL - ROTATING BLADES UNDER DECK
2	2	8770357	DECAL - STAND CLEAR OF FLYING OBJECTS
3	4	8770342	DECAL - LIFT POINT
4	1	8770358	DECAL - REMOVE KEY BEFORE MAINTENANCE
5	1	8770340	DECAL - READ OPERATOR'S MANUAL
6	2	1096446	DECAL - CUTTING HEIGHT
7	1	09.811.04	DECAL - 540 PTO

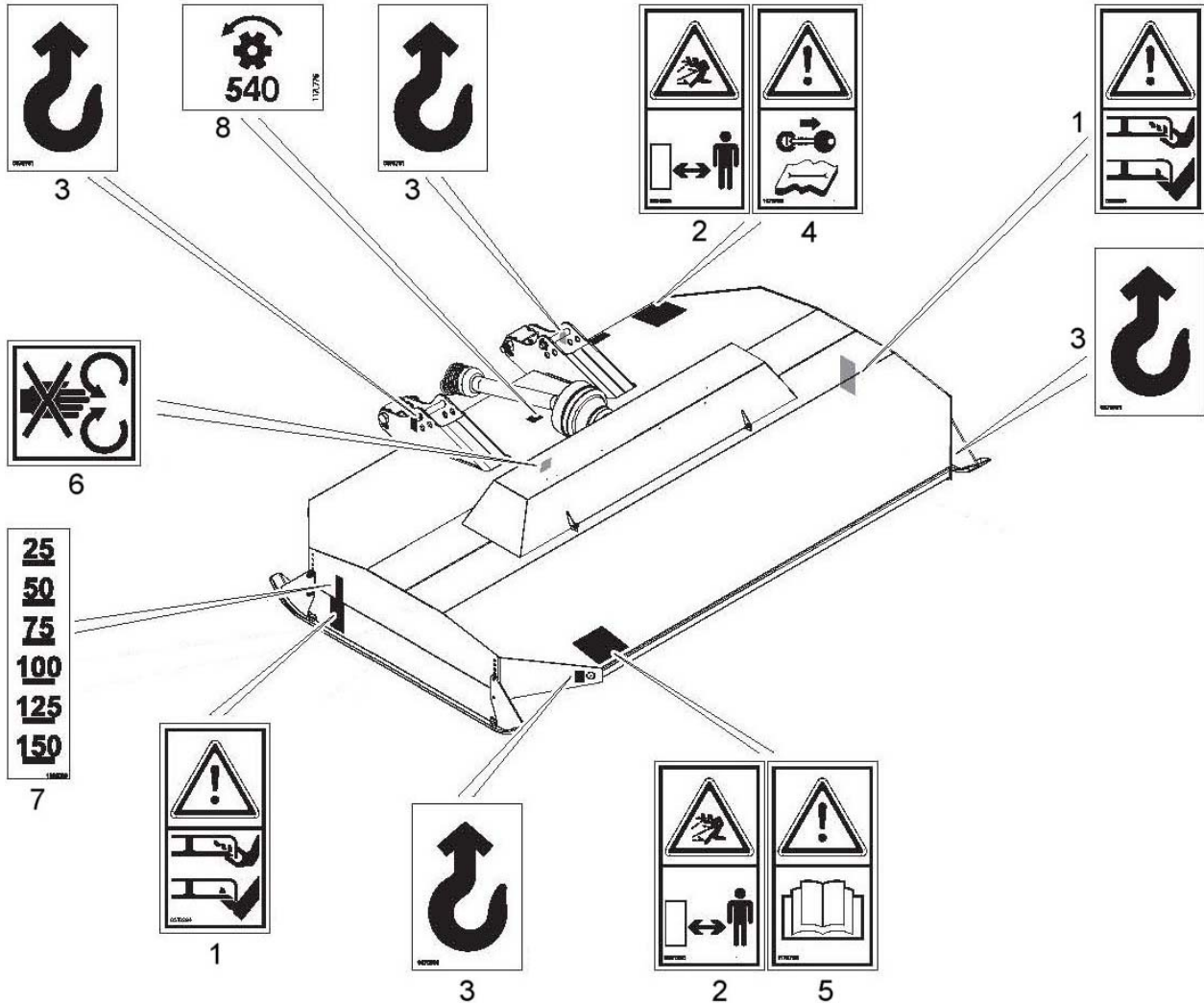

PT270 model illustrated - locations of decals may vary slightly on PT240 model

REF.	QTY.	PART No.	DESCRIPTION
		1096512	BASIC DECAL KIT - PT240 & PT270
1	2	09.821.19	DECAL - ROTATING BLADES UNDER DECK
2	2	8770357	DECAL - STAND CLEAR OF FLYING OBJECTS
3	4	8770342	DECAL - LIFT POINT
4	1	8770358	DECAL - REMOVE KEY BEFORE MAINTENANCE
5	1	8770340	DECAL - READ OPERATOR'S MANUAL
6	1	8770361	DECAL - HAND ENTANGLEMENT
7	2	1096446	DECAL - CUTTING HEIGHT
8	1	09.811.04	DECAL - 540 PTO

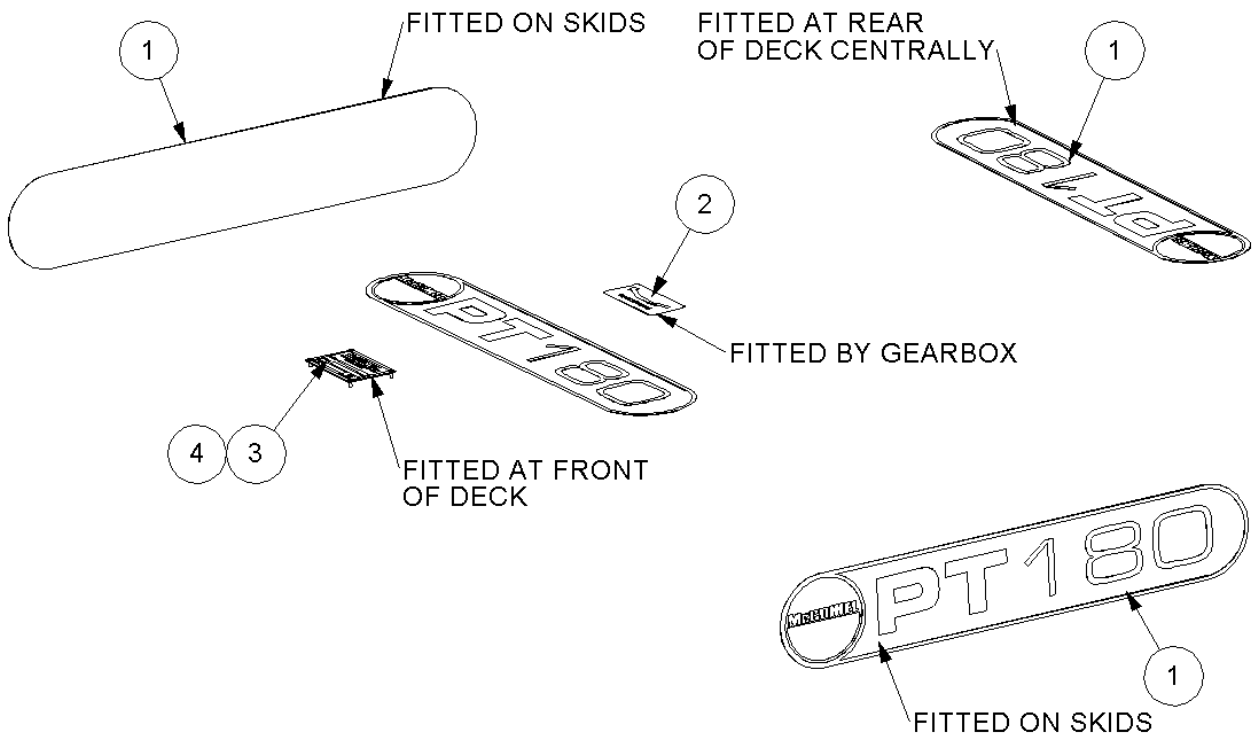

REF.	QTY.	PART No.	DESCRIPTION
		1096727	SPECIFIC DECAL KIT - PT180
1	3	1290976	DECAL - PT180
2	1	D138	DECAL - CW BLADE ROTATION
3	1	1335246	SERIAL No. PLATE
4	4	7103230	POP RIVET

Module(s): 1096729

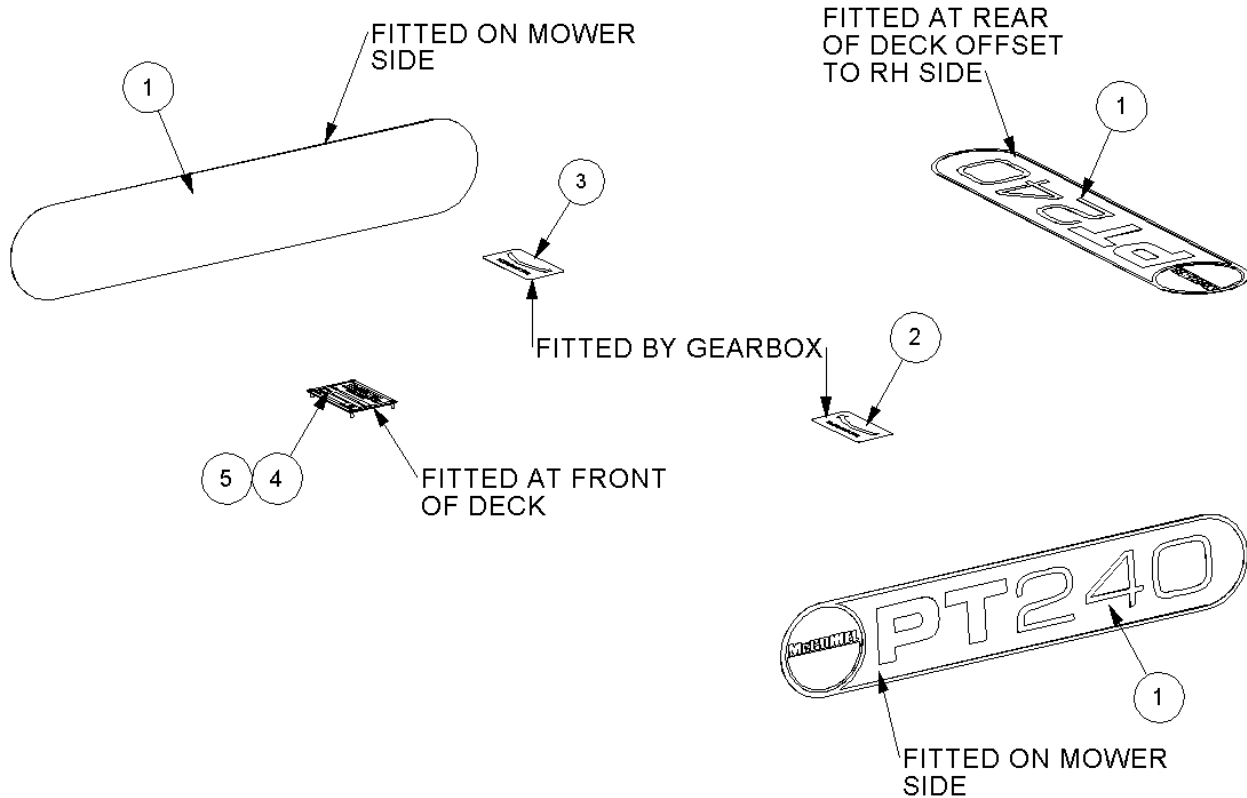

REF.	QTY.	PART No.	DESCRIPTION
		1096729	SPECIFIC DECAL KIT - PT270
1	3	1291014	DECAL - PT270
2	1	D138	DECAL - CW BLADE ROTATION
3	1	D137	DECAL - CCW BLADE ROTATION
4	1	1335246	SERIAL No. PLATE
5	4	7103230	POP RIVET

Module(s): 1096728

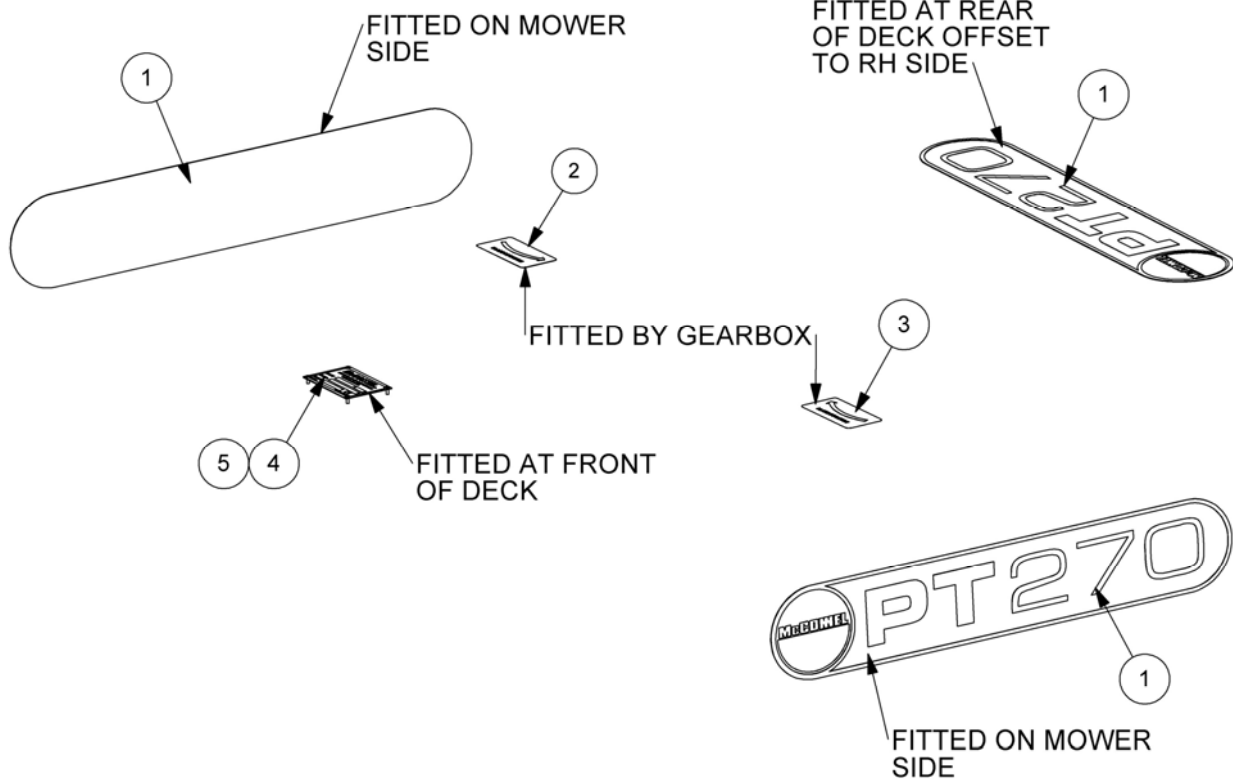

REF.	QTY.	PART No.	DESCRIPTION
		1096728	PT270 DECAL KIT
1	3	1290977	DECAL - PT270
2	1	D137	DECAL - CCW BLADE ROTATION
3	1	D138	DECAL - CW BLADE ROTATION
4	1	1335246	SERIAL No. PLATE
5	4	7103230	POP RIVET

Module(s): N/A

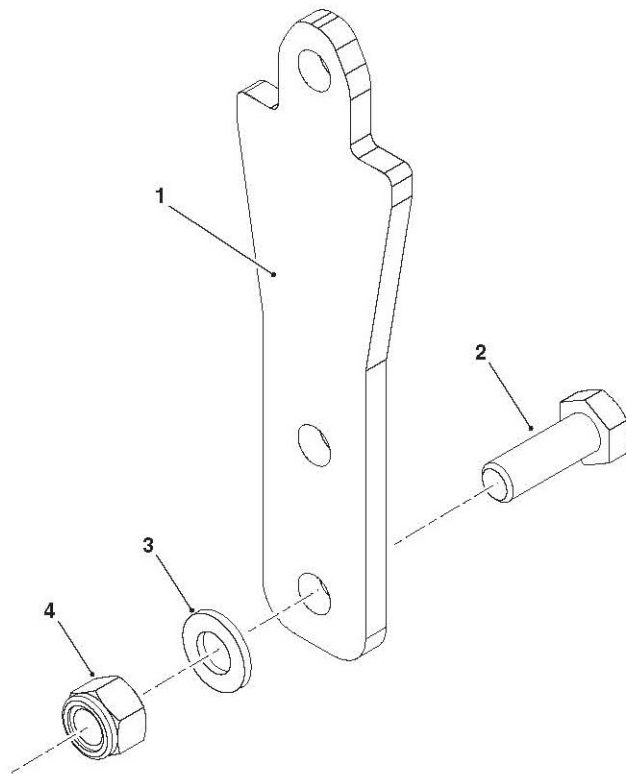

REF.	QTY.	PART No.	DESCRIPTION
			STACKING LEGS - PT180 / 240 / 270 Models
1	4	1096433	STACKING LEG
2	8	9313076	SETSCREW
3	8	1096420	WASHER
4	8	9163006	NYLOC NUT



McConnel Limited, Temeside Works, Ludlow, Shropshire SY8 1JL. England.
Telephone: 01584 873131. Facsimile: 01584 876463. www.mcconnel.com