

Publication 813
August 2015
Part No. 23671.13

PT SERIES TOPPERS

Models: PT180, PT240, PT240 Offset & PT270
SINGLE & TWIN ROTOR PASTURE TOPPERS



Operation Manual

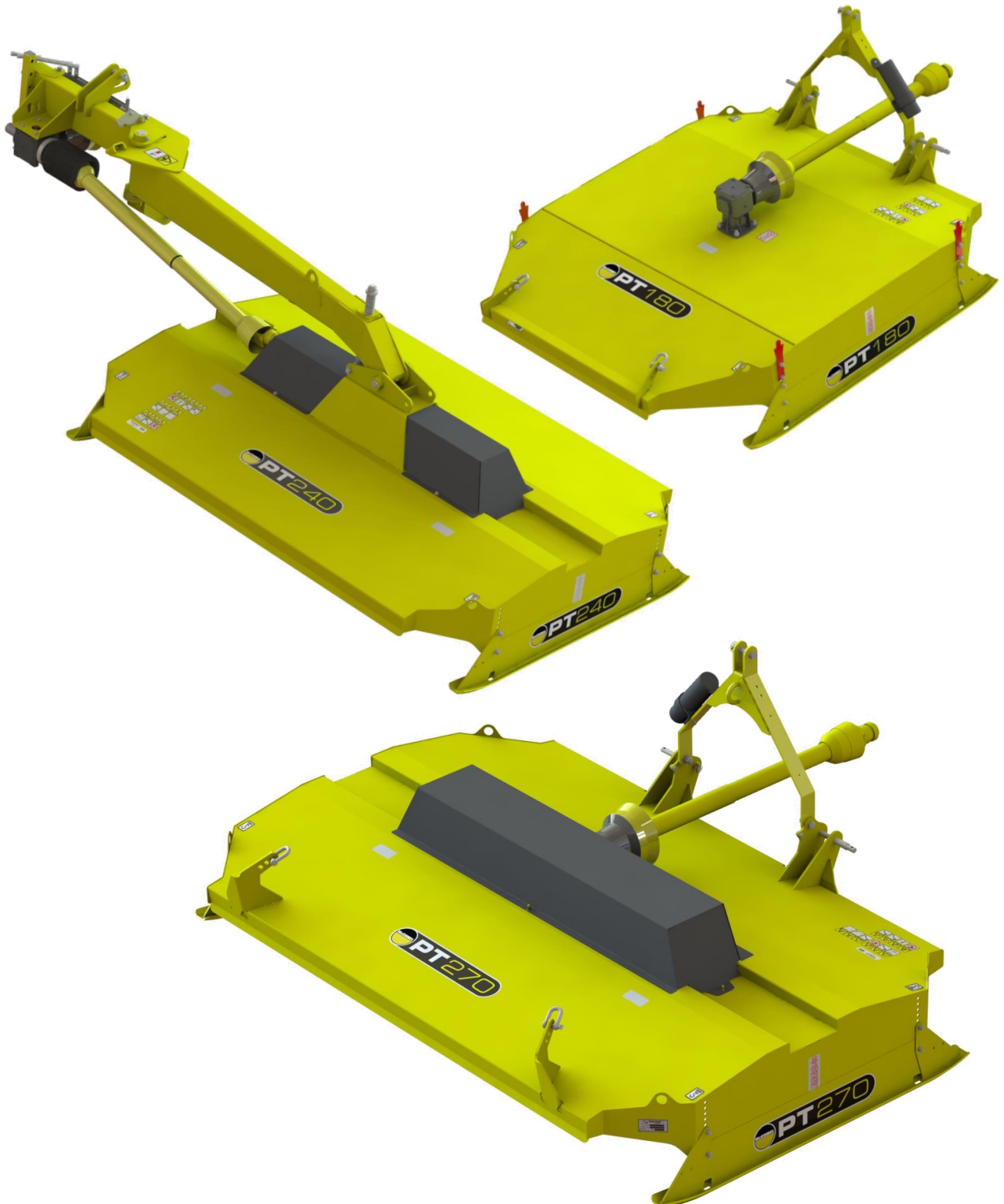

IMPORTANT

VERIFICATION OF WARRANTY REGISTRATION



DEALER WARRANTY INFORMATION & REGISTRATION VERIFICATION

It is imperative that the selling dealer registers this machine with McConnel Limited before delivery to the end user – failure to do so may affect the validity of the machine warranty.

To register machines go to the McConnel Limited web site at www.mcconnel.com, log onto 'Dealer Inside' and select the 'Machine Registration button' which can be found in the Service Section of the site. Confirm to the customer that the machine has been registered in the section below.

Should you experience any problems registering a machine in this manner please contact the McConnel Service Department on 01584 875848.

Registration Verification

Dealer Name:
Dealer Address:
Customer Name:
Date of Warranty Registration:/...../..... Dealer Signature:

NOTE TO CUSTOMER / OWNER

Please ensure that the above section above has been completed and signed by the selling dealer to verify that your machine has been registered with McConnel Limited.

IMPORTANT: During the initial 'bedding in' period of a new machine it is the customer's responsibility to regularly inspect all nuts, bolts and hose connections for tightness and re-tighten if required. New hydraulic connections occasionally weep small amounts of oil as the seals and joints settle in – where this occurs it can be cured by re-tightening the connection – *refer to torque settings chart below*. The tasks stated above should be performed on an hourly basis during the first day of work and at least daily thereafter as part of the machines general maintenance procedure.

TORQUE SETTINGS FOR HYDRAULIC FITTINGS

HYDRAULIC HOSE ENDS		
BSP	Setting	Metric
1/4"	18 Nm	19 mm
3/8"	31 Nm	22 mm
1/2"	49 Nm	27 mm
5/8"	60 Nm	30 mm
3/4"	80 Nm	32 mm
1"	125 Nm	41 mm
1.1/4"	190 Nm	50 mm
1.1/2"	250 Nm	55 mm
2"	420 Nm	70 mm

PORT ADAPTORS WITH BONDED SEALS		
BSP	Setting	Metric
1/4"	34 Nm	19 mm
3/8"	47 Nm	22 mm
1/2"	102 Nm	27 mm
5/8"	122 Nm	30 mm
3/4"	149 Nm	32 mm
1"	203 Nm	41 mm
1.1/4"	305 Nm	50 mm
1.1/2"	305 Nm	55 mm
2"	400 Nm	70 mm

WARRANTY POLICY

WARRANTY REGISTRATION

All machines must be registered, by the selling dealer with McConnel Ltd, before delivery to the end user. On receipt of the goods it is the buyer's responsibility to check that the Verification of Warranty Registration in the Operator's Manual has been completed by the selling dealer.

1. LIMITED WARRANTIES

- 1.01. *All mounted machines supplied by McConnel Ltd are warranted to be free from defects in material and workmanship from the date of sale to the original purchaser for a period of 12 months, unless a different period is specified.
All Self Propelled Machines supplied by McConnel Ltd are warranted to be free from defects in material and workmanship from the date of sale to the original purchaser for a period of 12 months or 1500 hours. Engine warranty will be specific to the Manufacturer of that unit.*
- 1.02. *All spare parts supplied by McConnel Ltd and purchased by the end user are warranted to be free from defects in material and workmanship from the date of sale to the original purchaser for a period of 6 months. All parts warranty claims must be supported by a copy of the failed part invoice to the end user. We cannot consider claims for which sales invoices are not available.*
- 1.03. *The warranty offered by McConnel Ltd is limited to the making good by repair or replacement for the purchaser any part or parts found, upon examination at its factory, to be defective under normal use and service due to defects in material or workmanship. Returned parts must be complete and unexamined. Pack the component(s) carefully so that any transit damage is avoided. All ports on hydraulic items should be drained of oil and securely plugged to prevent seepage and foreign body ingress. Certain other components, electrical items for example, may require particular care when packing to avoid damage in transit.*
- 1.04. *This warranty does not extend to any product from which McConnel Ltd's serial number plate has been removed or altered.*
- 1.05. *The warranty policy is valid for machines registered in line with the terms and conditions detailed and on the basis that the machines do not extend a period of 24 months or greater since their original purchase date, that is the original invoice date from McConnel Limited.
Machines that are held in stock for more than 24 months cannot be registered for warranty.*
- 1.06. *This warranty does not apply to any part of the goods, which has been subjected to improper or abnormal use, negligence, alteration, modification, fitment of non-genuine parts, accident damage, or damage resulting from contact with overhead power lines, damage caused by foreign objects (e.g. stones, iron, material other than vegetation), failure due to lack of maintenance, use of incorrect oil or lubricants, contamination of the oil, or which has served its normal life. This warranty does not apply to any expendable items such as blades, belts, clutch linings, filter elements, flails, flap kits, skids, soil engaging parts, shields, guards, wear pads, pneumatic tyres or tracks.*
- 1.07. *Temporary repairs and consequential loss - i.e. oil, downtime and associated parts are specifically excluded from the warranty.*
- 1.08. *Warranty on hoses is limited to 12 months and does not include hoses which have suffered external damage. Only complete hoses may be returned under warranty, any which have been cut or repaired will be rejected.*
- 1.09. *Machines must be repaired immediately a problem arises. Continued use of the machine after a problem has occurred can result in further component failures, for which McConnel Ltd cannot be held liable, and may have safety implications.*
- 1.10. *If in exceptional circumstances a non McConnel Ltd part is used to effect a repair, warranty reimbursement will be at no more than McConnel Ltd's standard dealer cost for the genuine part.*

- 1.11. *Except as provided herein, no employee, agent, dealer or other person is authorised to give any warranties of any nature on behalf of McConnell Ltd.*
- 1.12. *For machine warranty periods in excess of 12 months the following additional exclusions shall apply:*
 - 1.12.1. *Hoses, exposed pipes and hydraulic tank breathers.*
 - 1.12.2. *Filters.*
 - 1.12.3. *Rubber mountings.*
 - 1.12.4. *External electric wiring.*
 - 1.12.5. *Bearings and seals*
 - 1.12.6. *External Cables, Linkages*
 - 1.12.7. *Loose/Corroded Connections, Light Units, LED's*
 - 1.12.8. *Comfort items such as Operator Seat, Ventilation, Audio Equipment*
- 1.13. *All service work, particularly filter changes, must be carried out in accordance with the manufacturer's service schedule. Failure to comply will invalidate the warranty. In the event of a claim, proof of the service work being carried out may be required.*
- 1.14. *Repeat or additional repairs resulting from incorrect diagnosis or poor quality previous repair work are excluded from warranty.*

NB Warranty cover will be invalid if any non-genuine parts have been fitted or used. Use of non-genuine parts may seriously affect the machine's performance and safety. McConnell Ltd cannot be held responsible for any failures or safety implications that arise due to the use of non-genuine parts.

2. REMEDIES AND PROCEDURES

- 2.01. *The warranty is not effective unless the Selling Dealer registers the machine, via the McConnell web site and confirms the registration to the purchaser by completing the confirmation form in the operator's manual.*
- 2.02. *Any fault must be reported to an authorised McConnell Ltd dealer as soon as it occurs. Continued use of a machine, after a fault has occurred, can result in further component failure for which McConnell Ltd cannot be held liable.*
- 2.03. *Repairs should be undertaken within two days of the failure. Claims submitted for repairs undertaken more than 2 weeks after a failure has occurred, or 2 days after the parts were supplied will be rejected, unless the delay has been authorised by McConnell Ltd. Please note that failure by the customer to release the machine for repair will not be accepted as a reason for delay in repair or submitting warranty claims.*
- 2.04. *All claims must be submitted, by an authorised McConnell Ltd Service Dealer, within 30 days of the date of repair.*
- 2.05. *Following examination of the claim and parts, McConnell Ltd will pay, at their discretion, for any valid claim the invoiced cost of any parts supplied by McConnell Ltd and appropriate labour and mileage allowances if applicable.*
- 2.06. *The submission of a claim is not a guarantee of payment.*
- 2.07. *Any decision reached by McConnell Ltd. is final.*

3. LIMITATION OF LIABILITY

- 3.01. *McConnell Ltd disclaims any express (except as set forth herein) and implied warranties with respect to the goods including, but not limited to, merchantability and fitness for a particular purpose.*
- 3.02. *McConnell Ltd makes no warranty as to the design, capability, capacity or suitability for use of the goods.*
- 3.03. *Except as provided herein, McConnell Ltd shall have no liability or responsibility to the purchaser or any other person or entity with respect to any liability, loss, or damage caused or alleged to be caused directly or indirectly by the goods including, but not limited to, any indirect, special, consequential, or incidental damages resulting from the use or operation of the goods or any breach of this warranty. Notwithstanding the above limitations and warranties, the manufacturer's liability hereunder for damages incurred by the purchaser or others shall not exceed the price of the goods.*
- 3.04. *No action arising out of any claimed breach of this warranty or transactions under this warranty may be brought more than one (1) year after the cause of the action has occurred.*

4. MISCELLANEOUS

- 4.01. McConnel Ltd may waive compliance with any of the terms of this limited warranty, but no waiver of any terms shall be deemed to be a waiver of any other term.*
- 4.02. If any provision of this limited warranty shall violate any applicable law and is held to be unenforceable, then the invalidity of such provision shall not invalidate any other provisions herein.*
- 4.03. Applicable law may provide rights and benefits to the purchaser in addition to those provided herein.*

McConnel Limited



DECLARATION OF CONFORMITY

Conforming to EU Machinery Directive 2006/42/EC

We,

McCONNEL LIMITED, Temeside Works, Ludlow, Shropshire SY8 1JL, UK

Hereby declare that:

The Product; *Tractor Mounted Pasture Topper*

Product Code; *PTP6, PTP9*

Serial No. & Date Type

Manufactured in; *United Kingdom*

Complies with the required provisions of the Machinery Directive 2006/42/EC
The machinery directive is supported by the following harmonized standards;

- BS EN ISO 12100 (2010) Safety of machinery – General principles for design – Risk assessment and risk reduction.
- BS EN 349 (1993) + A1 (2008) Safety of machinery - Minimum distances to avoid the entrapment with human body parts.
- BS EN ISO 14120 (2015) Safety of machinery - Guards general requirements for the design and construction of fixed and movable guards.
- BS EN 4413 (2010) Hydraulic fluid power. Safety requirements for systems and their components.

McCONNEL LIMITED operates an ISO 9001:2008 quality management system, certificate number: FM25970.

This system is continually assessed by the;

British Standards Institution (BSI), Beech House, Milton Keynes, MK14 6ES, UK
BSI is accredited by UK Accreditation Service, accreditation number: UKAS 003.

The EC declaration only applies if the machine stated above is used in accordance with the operating instructions.

Signed *Responsible Person*
CHRISTIAN DAVIES on behalf of McCONNEL LIMITED

Status: *General Manager*

Date: *January 2018*

ROTARY MOWER INSPECTION AND MAINTENANCE

A daily equipment inspection of the tractor and mower should be conducted before the equipment is used. You may use the inspection sheets to assist with these daily inspections. Any damaged or missing guards should be repaired or replaced before operating the mower. Failure to repair the damaged shield can result in objects being thrown from the mower and possibly hitting the operator or bystander.

Inspect the Mower for Safe Operating Condition

- Make sure the driveline guards and shielding are in place and in good repair.
- Inspect the chain guards, flexible and/or solid deflector thrown object shielding to assure that they are in place on the front and rear of the mower deck and in good repair. Repair or replace any damaged or missing thrown object shields.
- Remove all debris and cut material from the deck and around the gearboxes.
- Ensure the mower cutting height is set high enough to reduce the possibility of the mower blades contacting the ground. Actual height will be dependent on the ground conditions. Increase the height when working in rough or undulating conditions.
- Inspect for broken, chipped, bent, missing, or severely worn blades. Replace damaged blades before operating the mower. Ensure the blade retaining bolts and fasteners are secure and tight.
- Lubricate the driveline universal joints and telescoping members daily.
- Inspect the wheel lug bolt/nuts to assure that they are tight.
- If mower is equipped with pneumatic tires, make sure they have the required air pressure.
- Inspect for worn or damaged decals and safety instructions. Replace unreadable, damaged or missing safety decals.
- Follow the operator's manual(s) inspection and maintenance instructions for lubricating parts, and keeping thrown object shielding, driveline guards, rotating parts shields, mower blades and decals in good repair.

Inspect the Tractor for Safe Operating Condition:

- Inspect the controls, lights, SMVs (Slow Moving Vehicle sign), seat belts, and ROPS to assure that they are in place and in good working order.
- Be sure the tires, wheels, lug bolts/nuts are in good condition.
- Make sure the tractor brakes and steering are in proper operating condition.
- Follow the operator's manual(s) inspection and maintenance procedures for keeping the tractor in good and safe condition before operating.

The inspection sheet on the following page should be kept in this book as a record. A second sheet is included for you to cut out and photocopy or the inspection sheets can be downloaded from our web site at;

<http://www.mcconnel.com/support/aftersales/default.aspx?nav=After Sales>



MOUNTED ROTARY MOWER PRE-OPERATION Inspection

Mower ID _____ Date: _____ Shift: _____

WARNING



Before conducting the inspection, make sure the tractor engine is off, the key removed, all rotation has stopped and the tractor is in park with the parking brake engaged. Make sure the mower is resting on the ground or securely blocked up.

Item	Condition at start of shift	Specific Comments if not O.K.
The Operator's Manual is in the Canister on the mower		
All Warning Decals are in place, clean and legible		
The mower decks are clear of cut grass and debris		
Chain Guards/Deflectors are in place & in good condition		
Driveline/Gearbox shields/guards are in good condition		
Driveline clutches are in good condition, not frozen		
Driveline telescoping members & u-joints are lubricated		
Driveline yokes are securely attached to tractor & mower		
Gearbox mounting bolts are tight		
Blade carrier retaining nut is tight		
Blades are not chipped, cracked, bent or worn out		
Blade bolts are tight		
Side skirts and skids are in good condition		
There are no holes or cracks in the machine deck		
Wheel nuts are tight		
All linkage mounting pins are securely fastened		
Lift height is restricted to prevent PTO hitting the deck		

Operators Signature: _____

DO NOT OPERATE an UNSAFE TRACTOR or MOWER



TRACTOR PRE-OPERATION Inspection

Power Arm ID _____ Date: _____ Shift: _____

WARNING



Before conducting the inspection, make sure the tractor engine is off, the key is removed all rotation has stopped and the tractor is in park with the parking brake engaged. Any implement attached to the tractor is firmly on the ground.

Item	Condition at start of shift	Specific Comments if not O.K.
The flashing lights function properly.		
All lights are clean and working correctly		
All cab windows are clean and wipers working correctly		
The SMV sign, where required, is clean and visible.		
The tyres are in good condition with correct pressure.		
The wheel nuts are tight.		
The tractor brakes are in good condition.		
The steering linkage is in good condition.		
There are no visible oil leaks.		
The hydraulic controls function properly.		
The ROPS or ROPS cab is in good condition.		
The seatbelt is in place and in good condition.		
The 3-point hitch is in good condition.		
The drawbar/pick up hook is secure & in good condition		
The PTO master shield is in place.		
The engine oil level is full.		
The brake fluid level is full.		
The power steering fluid level is full.		
The fuel level is adequate.		
The engine coolant fluid level is full.		
The radiator & oil cooler are free of debris.		
The air filter is in good condition		

Operators Signature: _____

DO NOT OPERATE an UNSAFE TRACTOR or MOWER



MOUNTED ROTARY MOWER PRE-OPERATION Inspection

Mower ID _____ Date: _____ Shift: _____

WARNING



Before conducting the inspection, make sure the tractor engine is off, the key removed, all rotation has stopped and the tractor is in park with the parking brake engaged. Make sure the mower is resting on the ground or securely blocked up.

Item	Condition at start of shift	Specific Comments if not O.K.
The Operator's Manual is in the Canister on the mower		
All Warning Decals are in place, clean and legible		
The mower decks are clear of cut grass and debris		
Chain Guards/Deflectors are in place & in good condition		
Driveline/Gearbox shields/guards are in good condition		
Driveline clutches are in good condition, not frozen		
Driveline telescoping members & u-joints are lubricated		
Driveline yokes are securely attached to tractor & mower		
Gearbox mounting bolts are tight		
Blade carrier retaining nut is tight		
Blades are not chipped, cracked, bent or worn out		
Blade bolts are tight		
Side skirts and skids are in good condition		
There are no holes or cracks in the machine deck		
Wheel nuts are tight		
All linkage mounting pins are securely fastened		
Lift height is restricted to prevent PTO hitting the deck		

Operators Signature: _____

DO NOT OPERATE an UNSAFE TRACTOR or MOWER



TRACTOR PRE-OPERATION Inspection

Power Arm ID _____ Date: _____ Shift: _____

WARNING



Before conducting the inspection, make sure the tractor engine is off, the key is removed all rotation has stopped and the tractor is in park with the parking brake engaged. Any implement attached to the tractor is firmly on the ground.

Item	Condition at start of shift	Specific Comments if not O.K.
The flashing lights function properly.		
All lights are clean and working correctly		
All cab windows are clean and wipers working correctly		
The SMV sign, where required, is clean and visible.		
The tyres are in good condition with correct pressure.		
The wheel nuts are tight.		
The tractor brakes are in good condition.		
The steering linkage is in good condition.		
There are no visible oil leaks.		
The hydraulic controls function properly.		
The ROPS or ROPS cab is in good condition.		
The seatbelt is in place and in good condition.		
The 3-point hitch is in good condition.		
The drawbar/pick up hook is secure & in good condition		
The PTO master shield is in place.		
The engine oil level is full.		
The brake fluid level is full.		
The power steering fluid level is full.		
The fuel level is adequate.		
The engine coolant fluid level is full.		
The radiator & oil cooler are free of debris.		
The air filter is in good condition		

Operators Signature: _____

DO NOT OPERATE an UNSAFE TRACTOR or MOWER

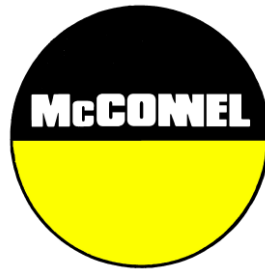

McCONEL LIMITED



McConnel Limited
Temeside Works
Ludlow
Shropshire SY8 1JL
England

Telephone: 01584 873131
www.mcconnel.com

LIST OF CONTENTS

General Information	1
Machine Description	2
General Arrangement	3
General Specifications	7
Dimensions	8
Safety Information	13
Safety Decals	25
Machine Preparation	26
Tractor Preparation	27
Tractor Requirements	27
Attaching the Machine	28
Setting Cutting Height	30
PTO Installation	30
Lubricants	32
Installation Checks	33
Hydraulic Hoses	34
General Operation	36
Machine Inspection Record	37
Operator Use and Adjustment	38
Cutting Height Adjustment	38
Shear Bolt Protection	39
Transportation	39
Driving on Public Roads	40
Cutting Deployment and Retraction	40
Start-Up	42
Stopping the Machine	42
Removal, Storage and Disposal	43
Maintenance	46
Regular Maintenance Chart	46
PT180 Driveline	48
PT240 & PT270 Driveline	49
PT240 Offset Driveline	52
Blades	54
Blade Carrier	54
Blade Bushes	55
Fastener Torque Guidelines	56
Trouble Shooting Chart	57

GENERAL INFORMATION

Read this manual before fitting or operating the machine or accessory. Whenever any doubt exists contact your local dealer or the McConnel Service Department for assistance.

Only use 'Genuine McConnel Parts' on McConnel machinery and equipment.

DEFINITIONS: *The following definitions apply throughout this manual;*

⚠ DANGER

DANGER: Alerts to a hazardous situation which will result in death or serious injury if not observed carefully.

⚠ WARNING

WARNING: Alerts to a hazardous situation which could result in death or serious injury if not observed carefully.

⚠ CAUTION

CAUTION: Alerts to a hazardous situation which could result in damage to the machine and/or equipment if not observed carefully.

NOTICE

NOTICE: Specific or general information considered important or useful to emphasise.

LEFT HAND (LH) & RIGHT HAND (RH): *These terms are applicable to the machine when fitted to the tractor and viewed from the rear; these terms also apply to tractor references.*

SERIAL PLATE

All machines are equipped with a serial number plate containing important information relating to the machine including a unique serial number used for identification purposes.

Note: Images in this manual are provided for instruction and informational purposes only and may not show components in their entirety. In certain instances images may appear different to the actual machine; where this occurs the general procedure will be basically the same.

MACHINE & DEALER INFORMATION

Record the serial number of your machine on this page and always quote it when ordering parts. Whenever information concerning the machine is requested remember to also state the make and model of tractor to which the machine is fitted.	
Machine Serial Number:	Installation Date:
Machine Model Details:	
Dealer Name & Branch:	
Dealer Address:	
Dealer Telephone No:	
Dealer Email Address:	

MACHINE DESCRIPTION

Intended usage

PT Series Toppers have been developed for use by farms and small contractors and are perfect for grasslands and paddocks.

The machines are primarily designed for the topping of grass pasture land after grazing, or for thistle and weed control on agricultural land. They are not designed for grass mowing, set-aside cutting, or brush/woodland clearance.

Models are available in cutting widths of 1.8m, 2.4m and 2.75m and are suitable for use with tractors from 30 to 70HP. Cutting height of the machine is manually adjustable and features a 'self-levelling' system to ensure the deck remains parallel irrespective of the cutting height.

PT Toppers are specifically designed for use on level, undulating or gently inclined ground with a duty cycle of 400 hours per annum.

In the interest of safety and for protection of your mower you must never use this machine to perform tasks it was not designed to do.

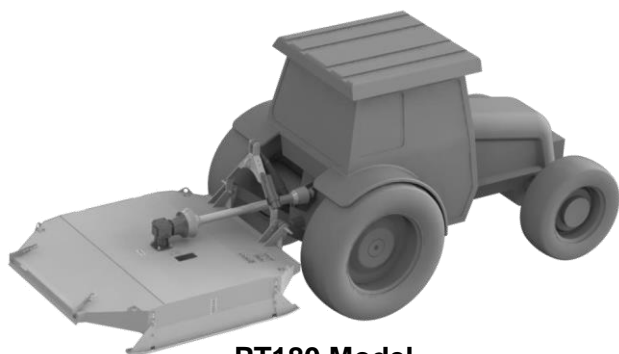

PT180 Model

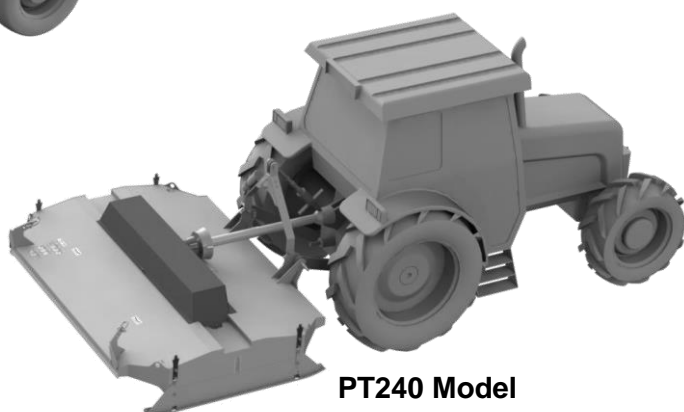

PT240 Model

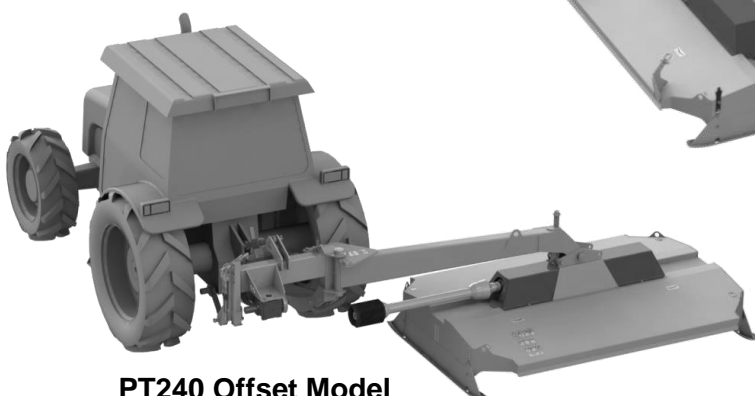

PT240 Offset Model

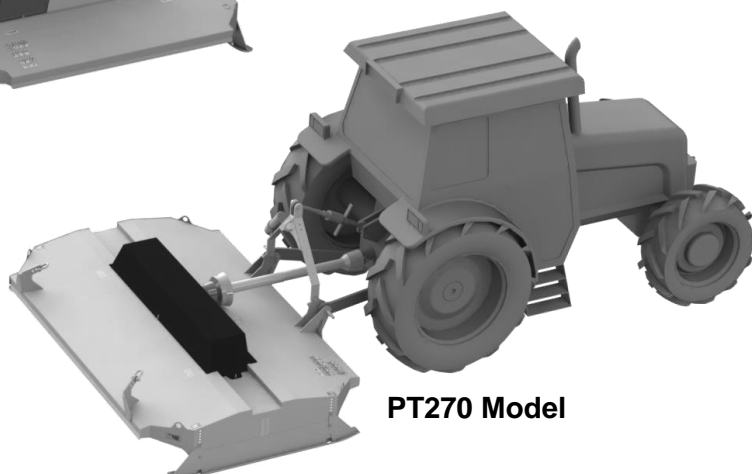

PT270 Model

General Arrangement – PT180 Model

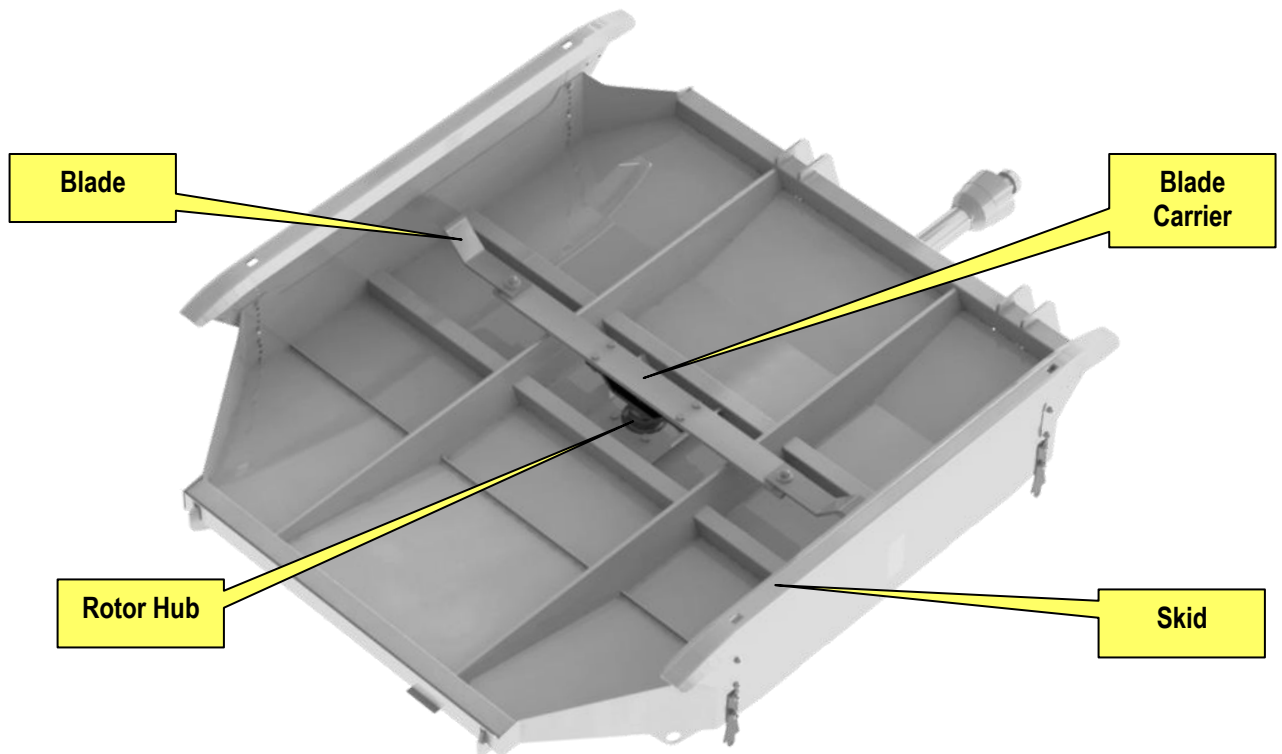
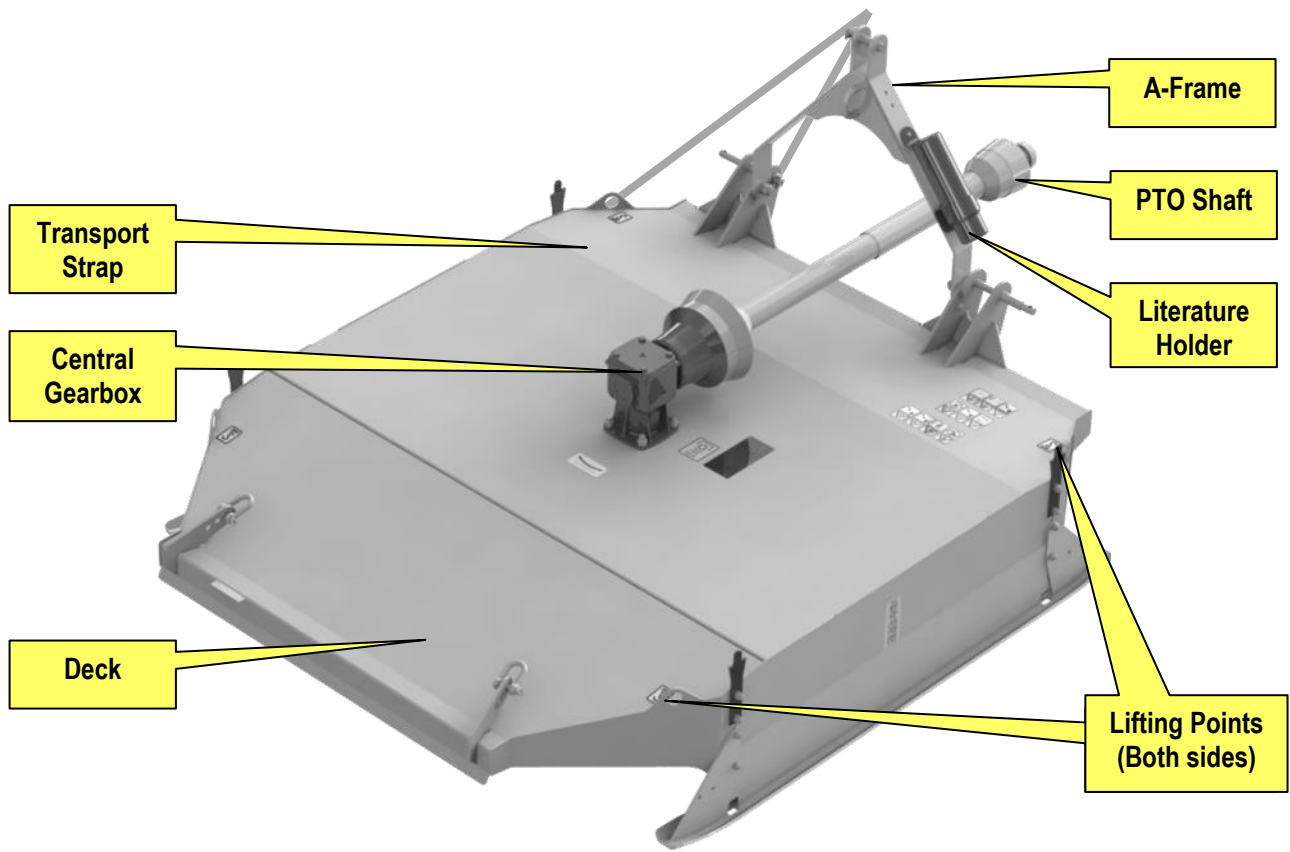

General Arrangement – PT240 Model

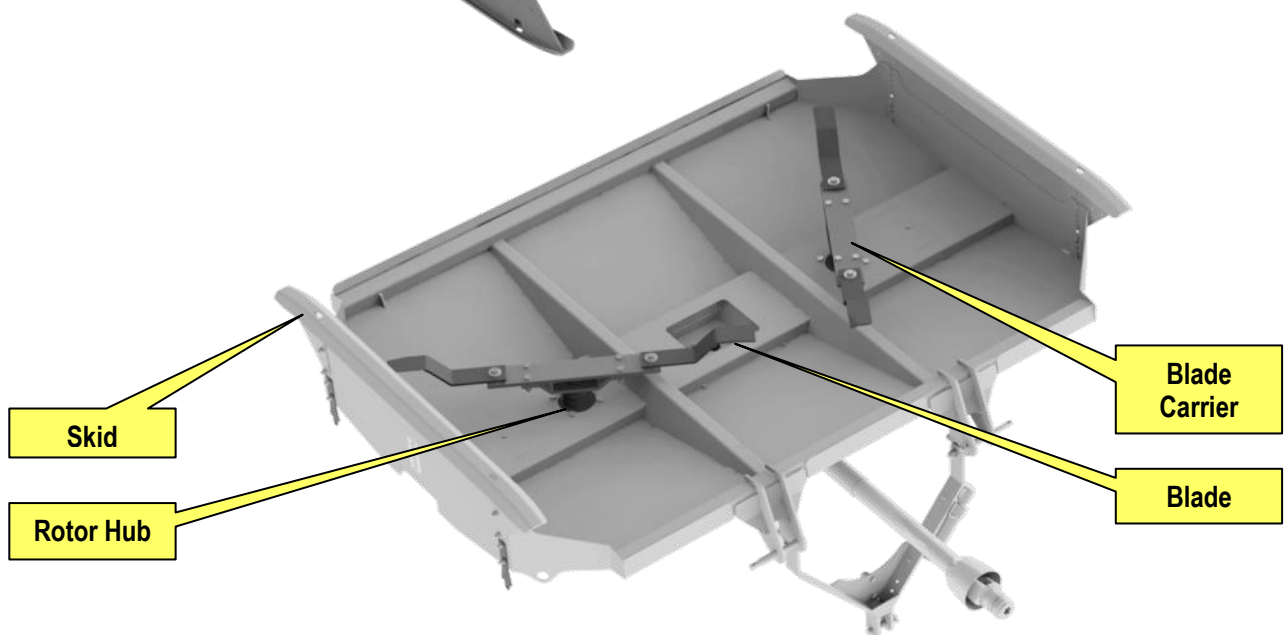
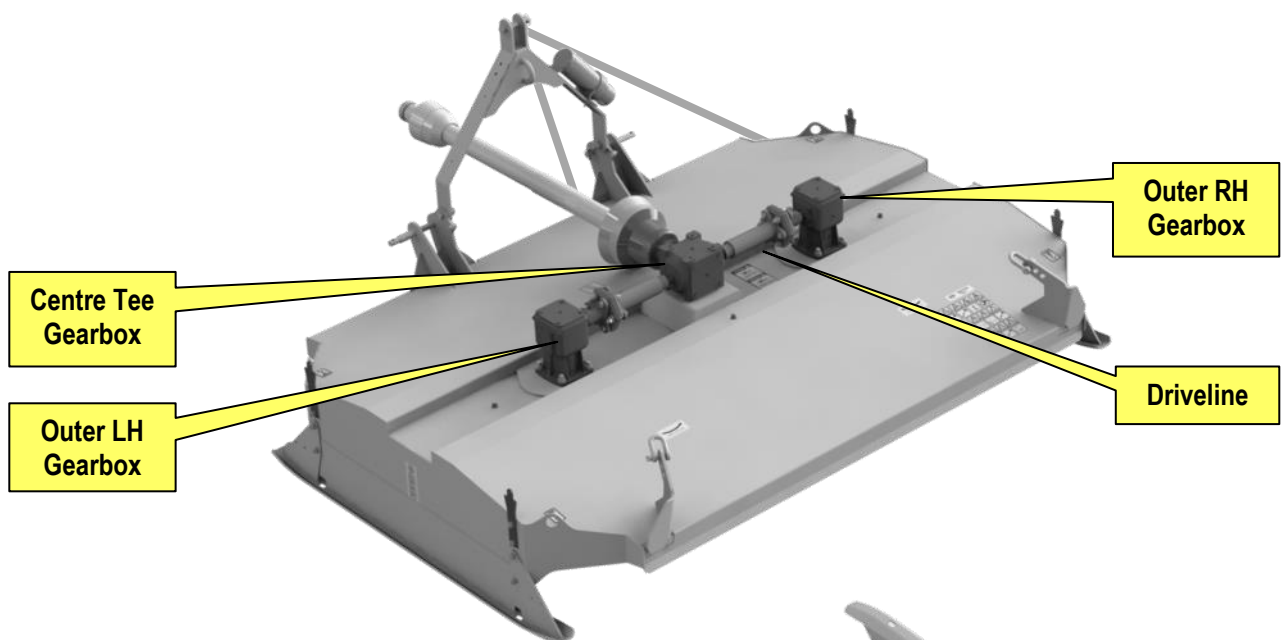
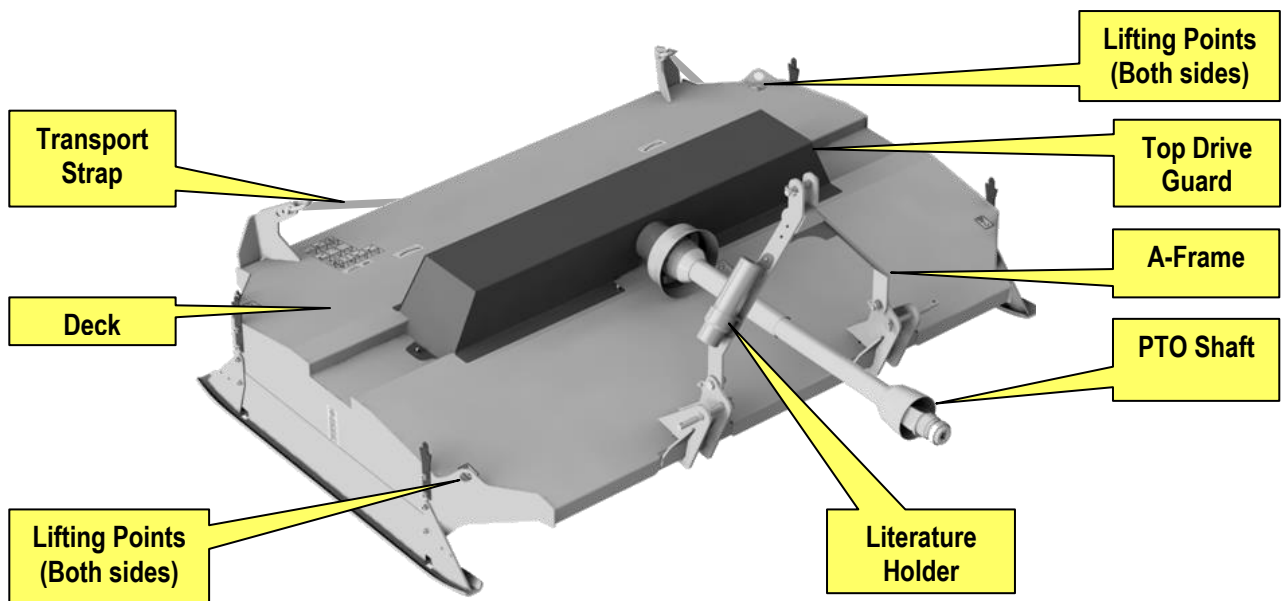

General Arrangement – PT240 Offset Model

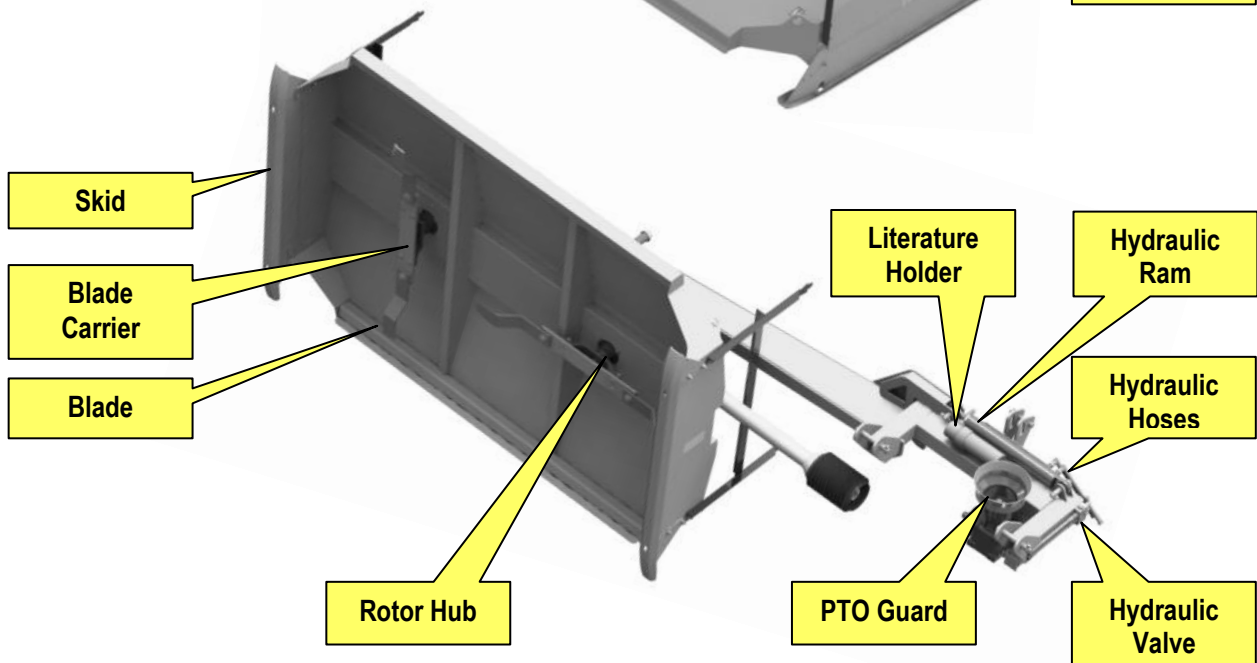
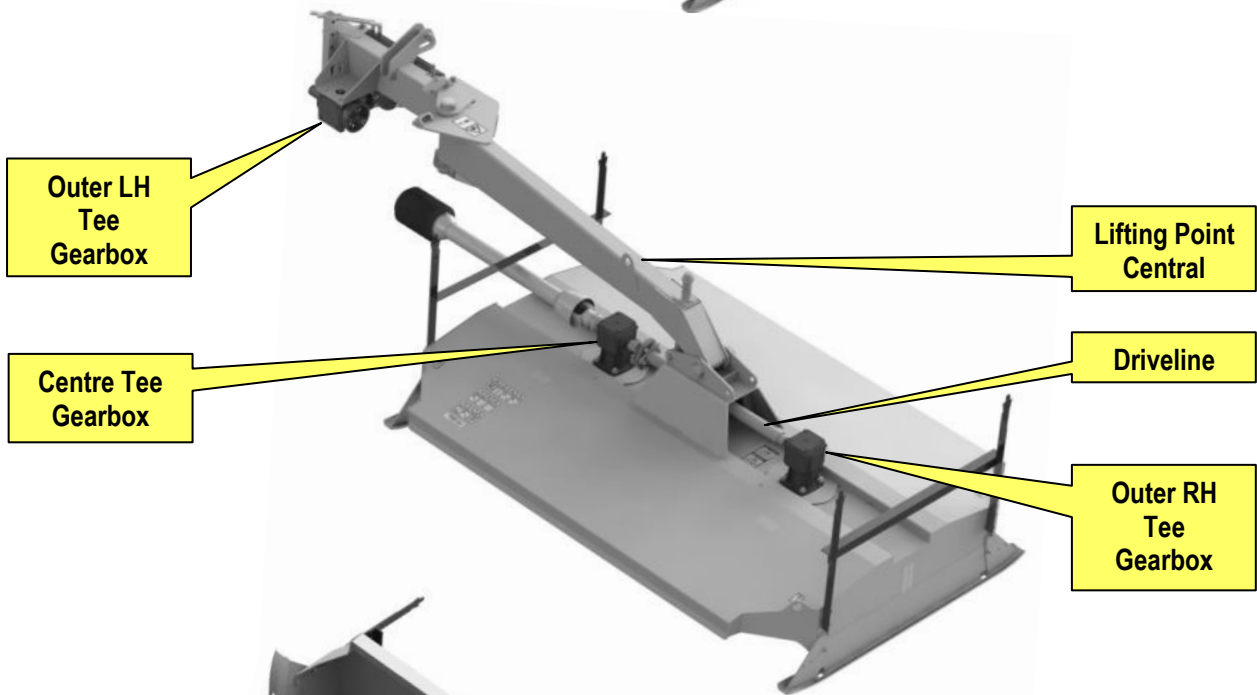
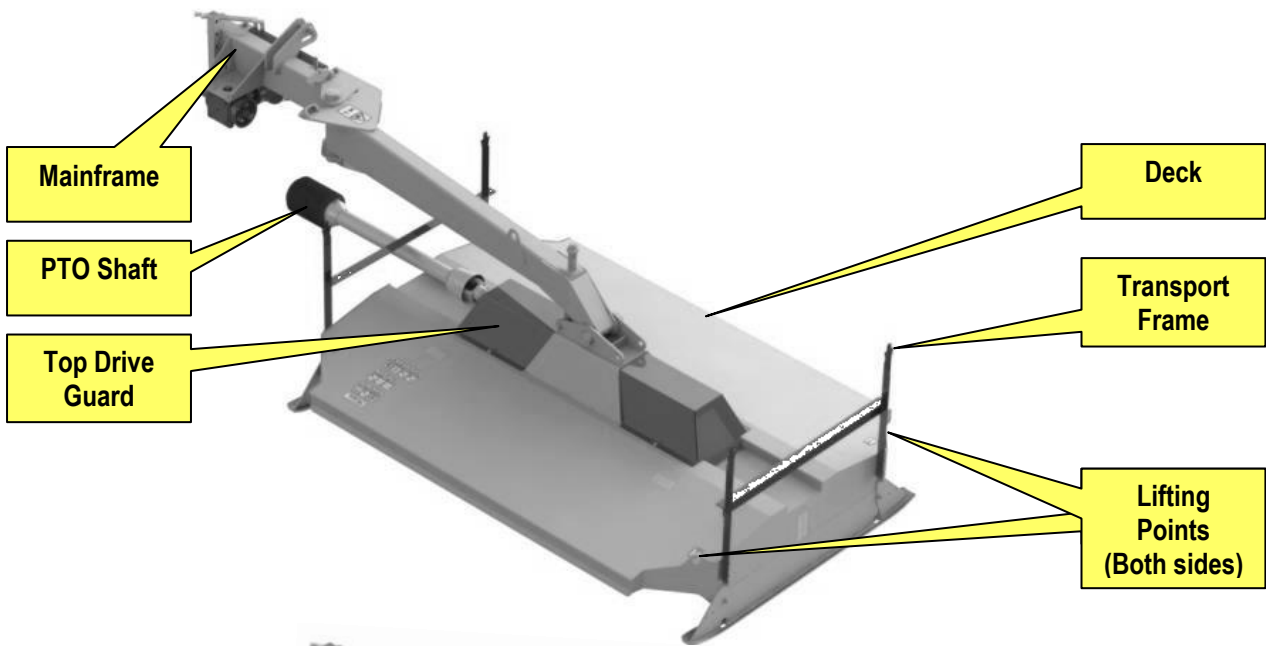

General Arrangement – PT270 Model

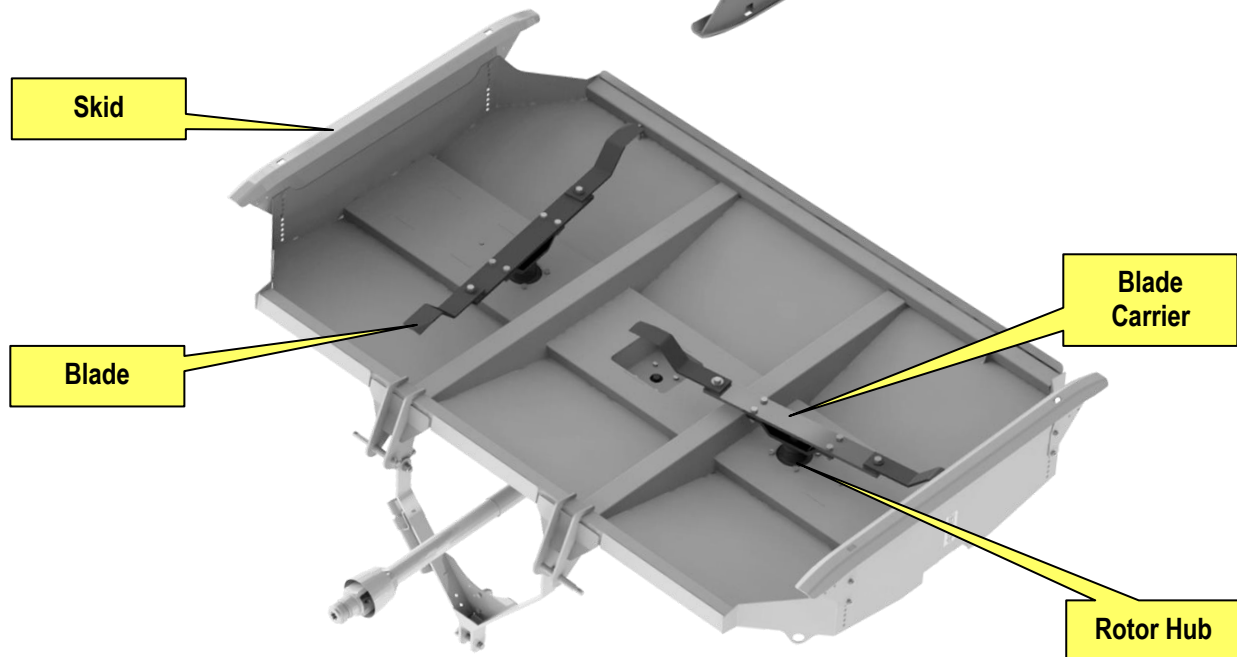
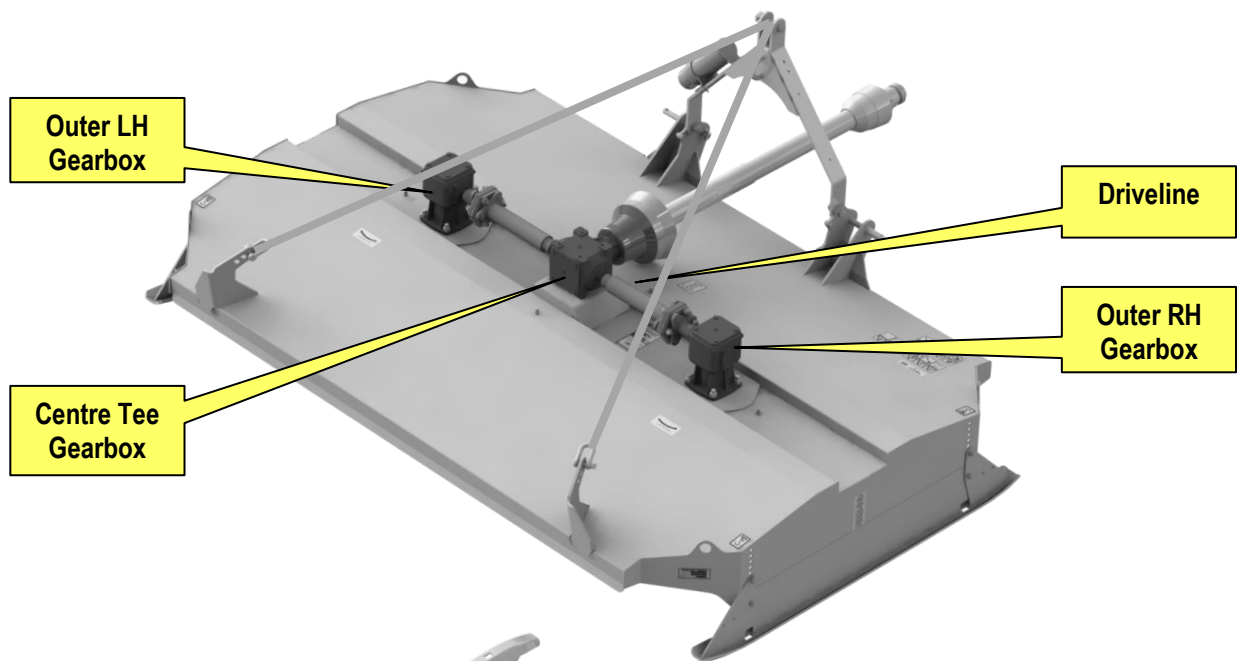
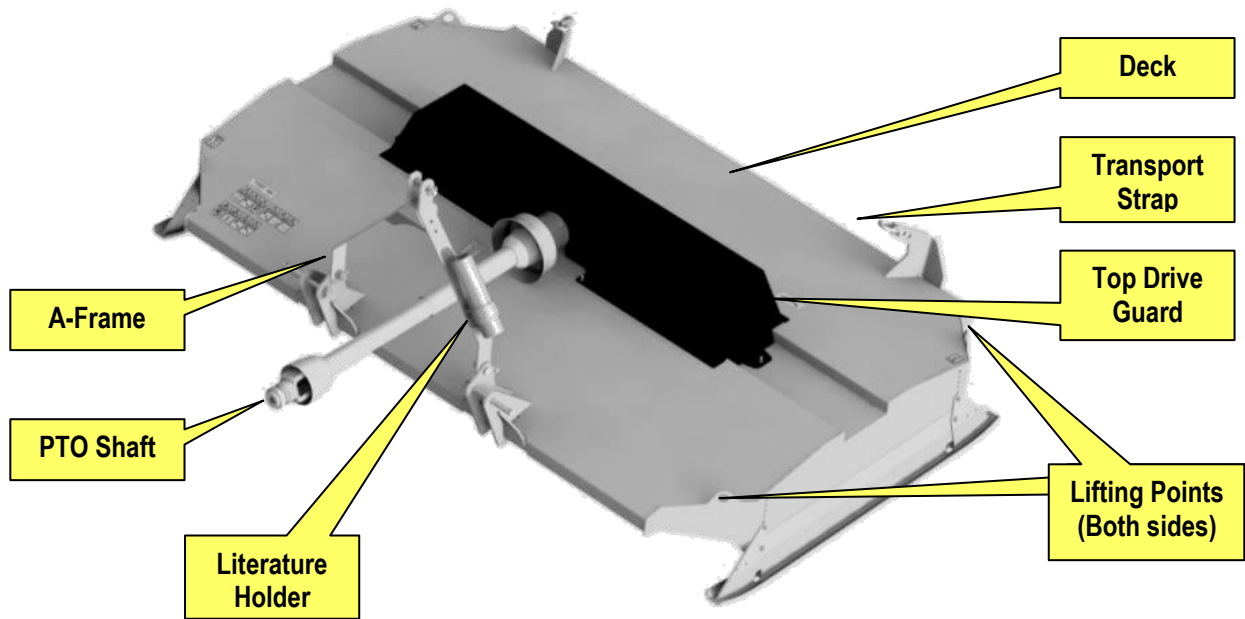

Machine Rotation Convention

The layout and naming convention used throughout this manual are as follows:
For a clockwise output from the tractor unit, the LH Gearbox has a Clockwise cutting action; the RH gearbox has an anti-clockwise cutting action. Refer to illustration below.

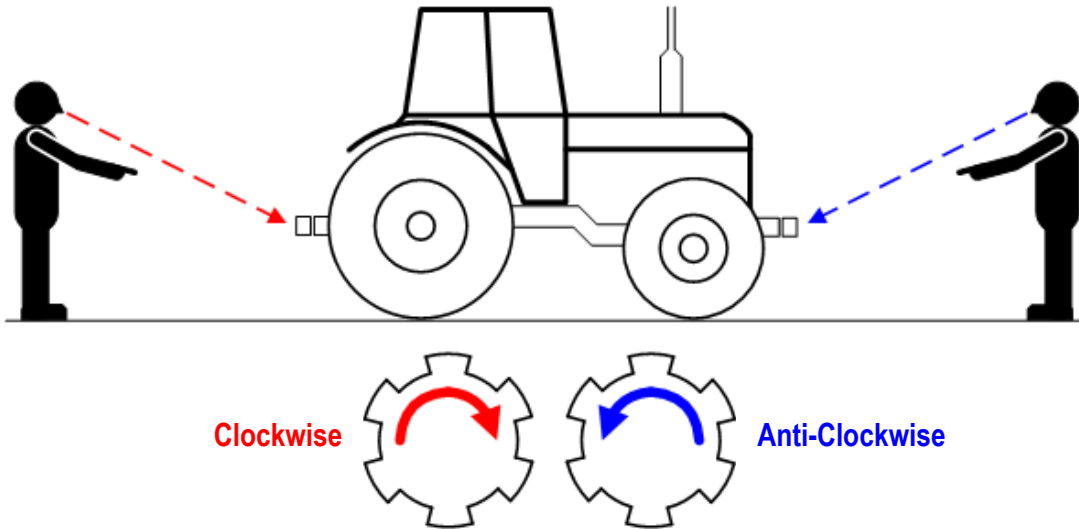

General Specifications

SPECIFICATION DESCRIPTION	PT180	PT240	PT240 (Offset)	PT270
Tractor Power Requirement (<i>Minimum</i>)	30HP / 22kW	30HP / 22kW	30HP / 22kW	30HP / 22kW
PTO Speed	540RPM	540RPM	540RPM	540RPM
Method of Attachment	3-Point Linkage	3-Point Linkage	3-Point Linkage	3-Point Linkage
Mounting Type	Cat. 1 & 2	Cat. 1 & 2	Cat. 2	Cat. 1 & 2
Gearbox Rated Input Power	40HP / 29.4kW	N/A	N/A	N/A
Splitter Gearbox Rated Input Power	N/A	55HP / 40.4kW	55HP / 40.4kW	55HP / 40.4kW
Outer Gearbox Rated Input Power	N/A	30HP / 22.0kW	N/A	30HP / 22.0kW
Central Gearbox Rated Input Power	N/A	N/A	30HP / 22.0kW	N/A
LH Gearbox Rated Input Power	N/A	N/A	55HP / 40.4kW	N/A
RH Gearbox Rated Input Power	N/A	N/A	30HP / 22.0kW	N/A
Cutting Width	1.80m	2.40m	2.40m	2.75m
Machine Width - Work Position (<i>Overall</i>)	1958mm	2683mm	4441mm	2978mm
Machine Width in Transport Position	1958mm	2683mm	1855mm	2978mm
Machine Height in Transport Position (*)	1570mm	1536mm	1608mm	1518mm
Machine Length (<i>Overall</i>)	2330mm	2005mm	4441mm	2005mm
Machine Weight	330kg	460kg	680kg	470kg
Cutting Height (<i>Minimum / Maximum</i>)	50mm / 175mm	50mm / 175mm	50mm / 175mm	50mm / 175mm
Blade Tip Speed - Centre Cutting Unit	75 m/s	-	-	-
Blade Tip Speed - Outer Cutting Unit(s)	N/A	71 m/s	71 m/s	78 m/s
Blade Overlap	N/A	93mm	93mm	67mm
Cutting Units (<i>No. of Rotors</i>)	1	2	2	2
Number of Blade Carriers	1	2	2	2
Number of Blades	2	4	4	4
Number of Skids	2	2	2	2

(*) Guide measurement only; this dimension will vary depending on particular tractor used and mounted height of the machine.

Dimensions – PT180 Model

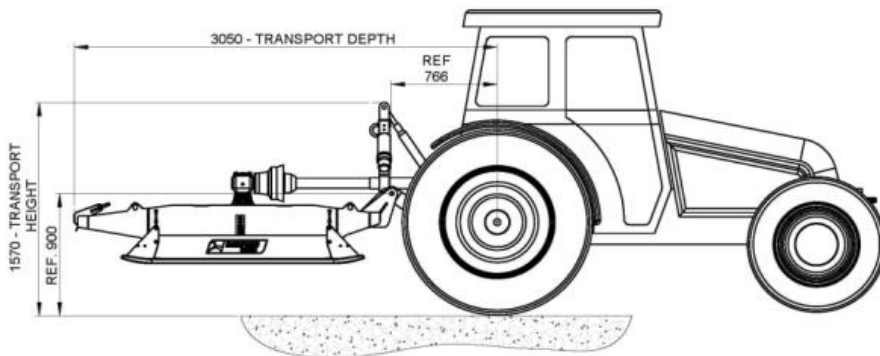
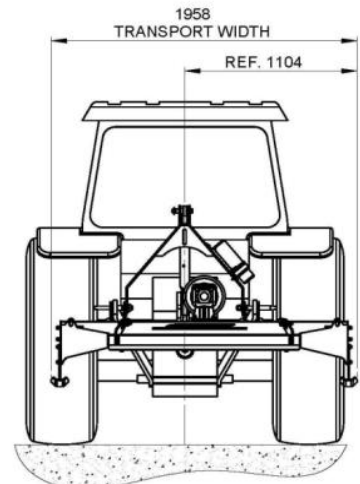
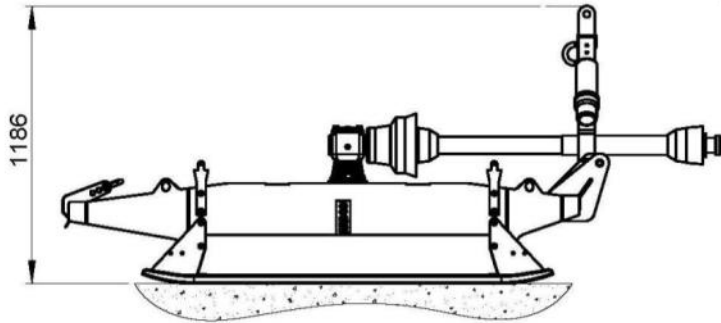
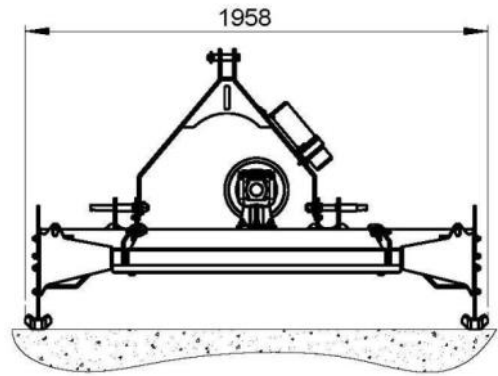
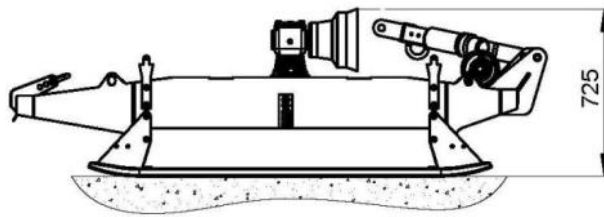
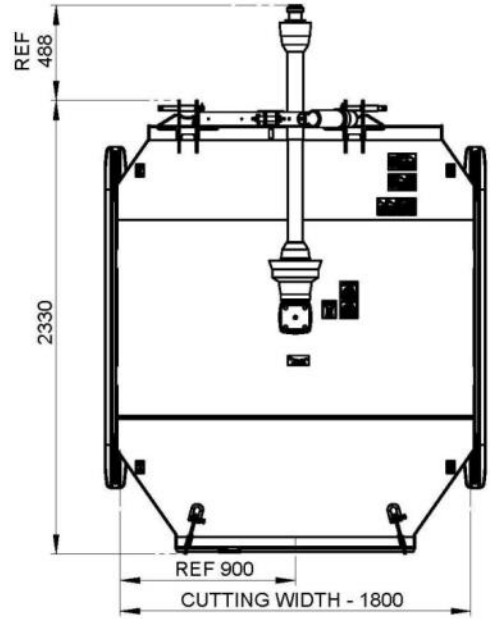
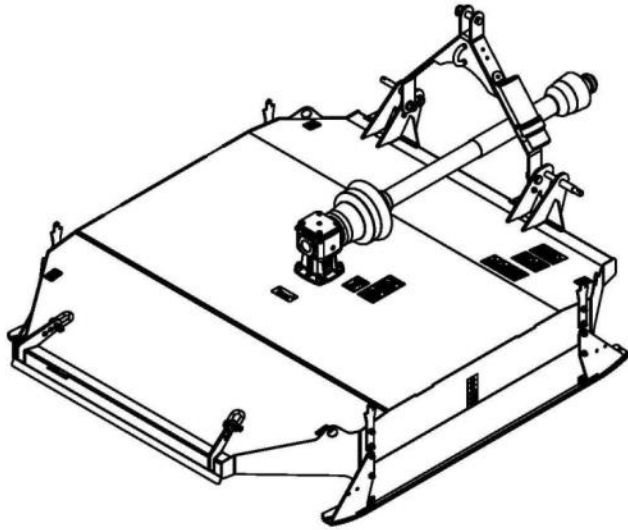

Dimensions – PT240 Model

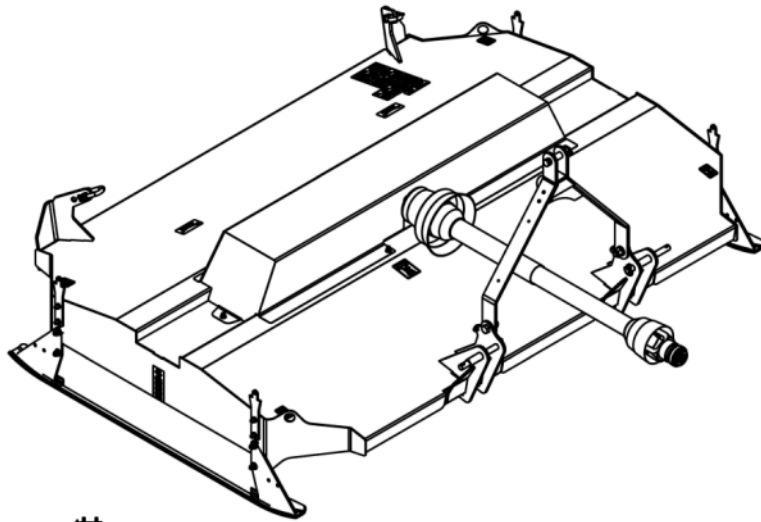

NOTE. SKID SHOWN IN HIGHEST POSITION

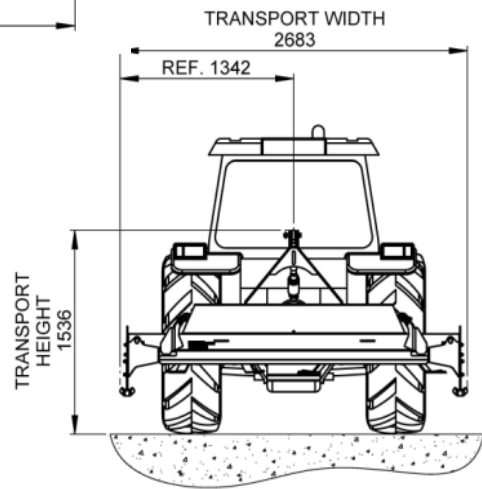
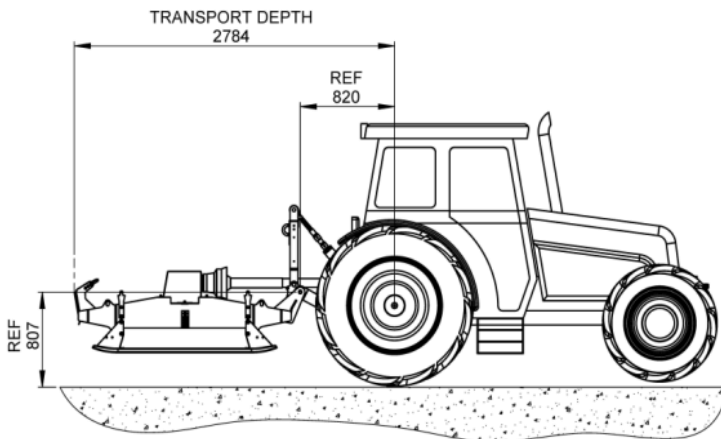
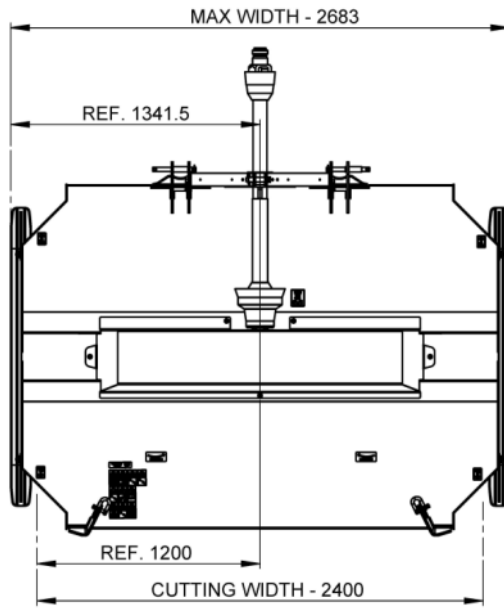
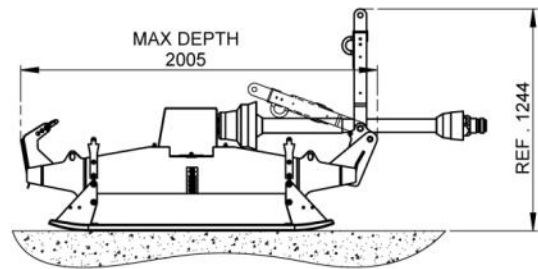
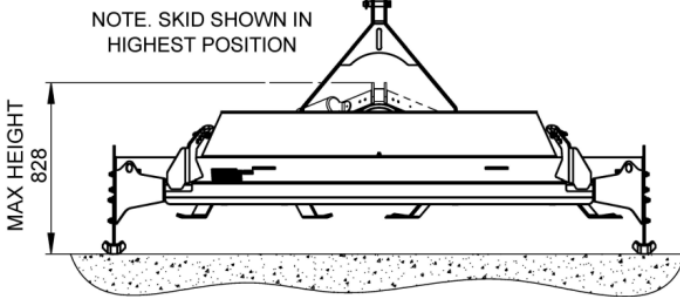

Dimensions – PT240 Offset Model

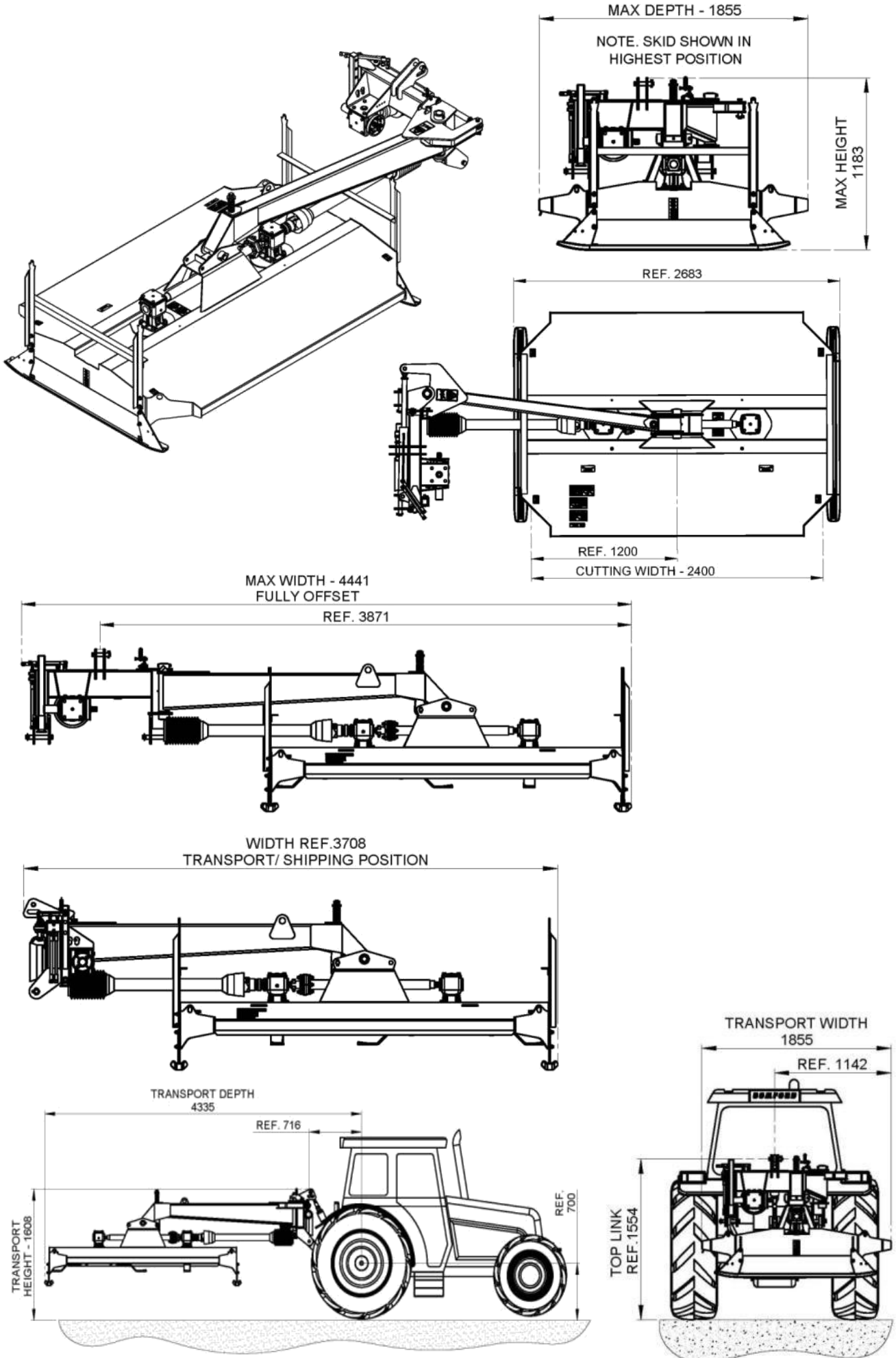

Dimensions – PT270 Model

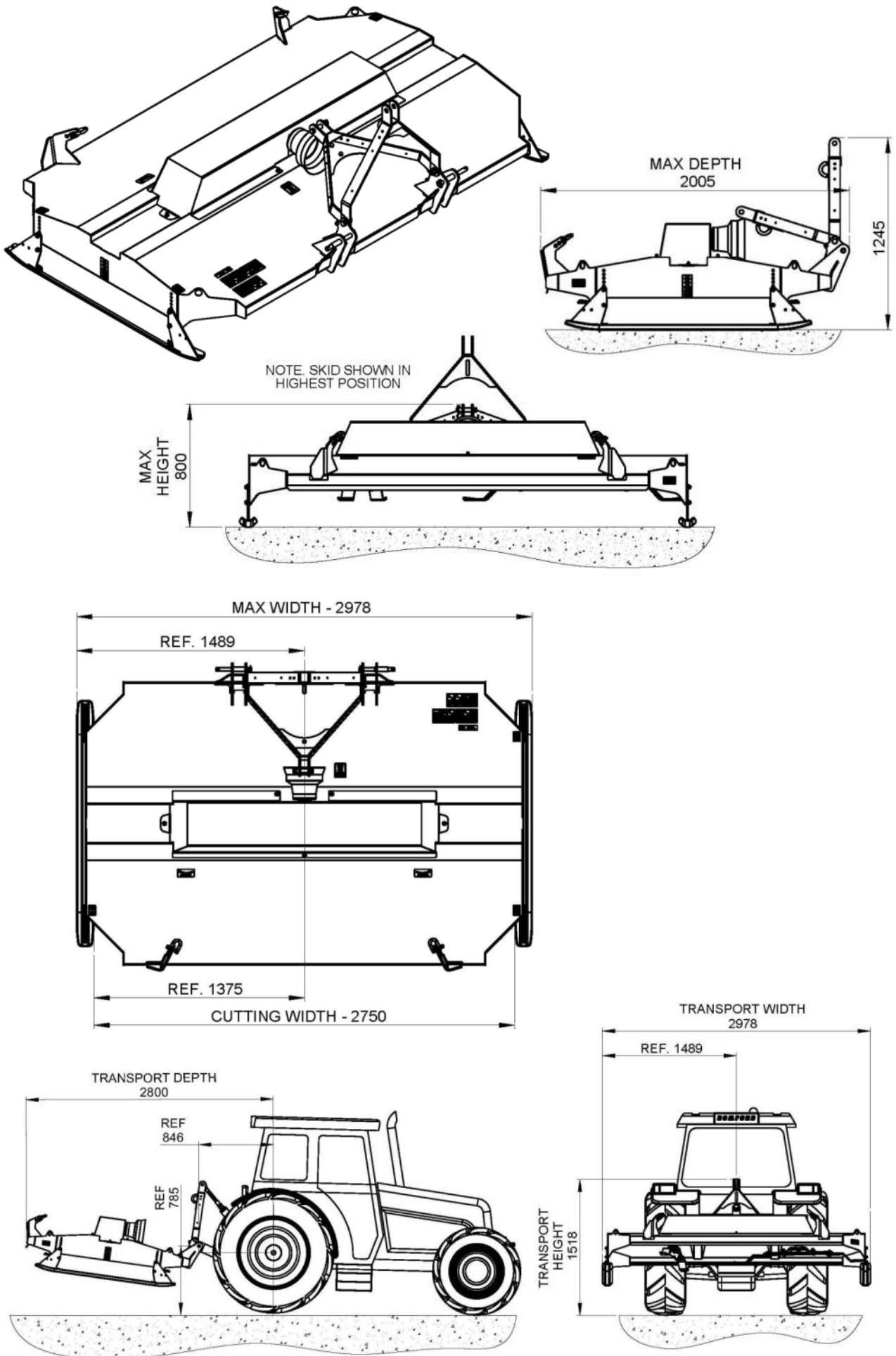

Lifting Points

Handling of machines should always be performed using suitable overhead lifting equipment with a minimum safe lifting capacity over and above the maximum weight of the machine. Always ensure the machine is balanced during the lifting procedure and that all bystanders are kept well clear of the raised machine.

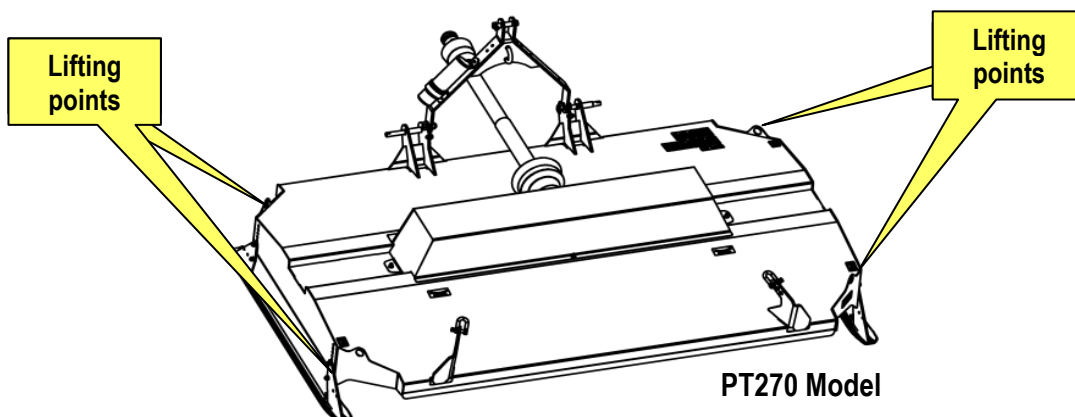
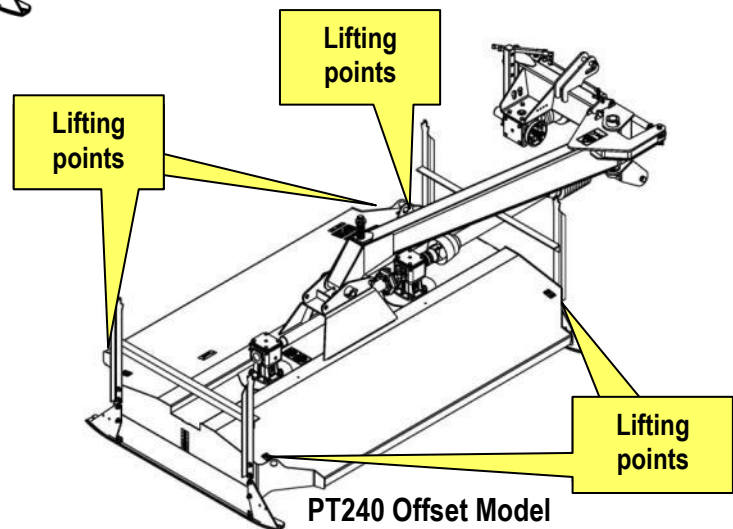
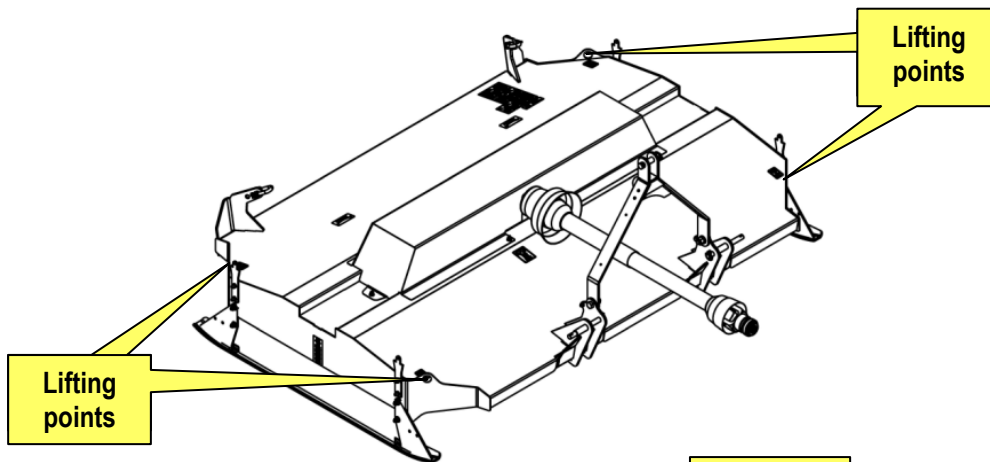
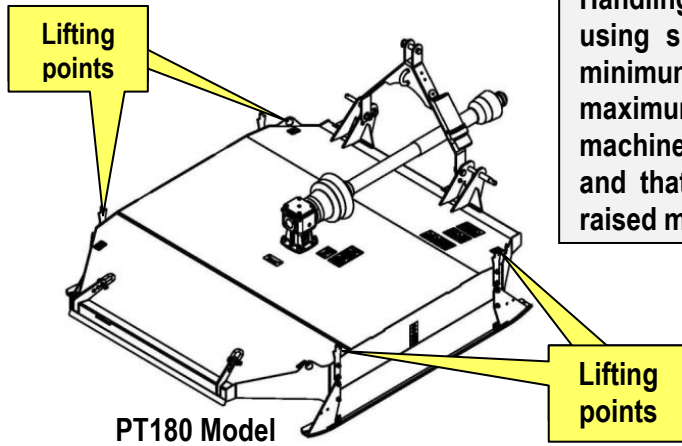

SAFETY

Operators

This machine should be operated, serviced, and repaired only by persons who are familiar with its particular characteristics and who are acquainted with the relevant safety procedures. Accident prevention regulations, all other generally recognised regulations on safety and occupational medicine, and all road traffic regulations must also be observed at all times.

This operator's manual should be regarded as part of the machine. The operator should read the following pages carefully and be familiar with the contents before commencing work. A familiar knowledge of the operator instruction manual forms an essential part of the training record for a competent user. Operators need to be competent and fully capable of operating this machine in a safe and efficient way prior to attempting to use it in any public place

Every employee must be given training at regular intervals on how to use this machinery (at least once a year) in accordance with the guide lines issued by the employer's insurance. Untrained or unauthorised members of staff must not use this machine.

In the interests of safety, please ensure that the instructions referred to above are brought to the attention of all your employees who are to use the equipment. We recommend that the use of this equipment is restricted to capable trained operatives. Persons under the age of sixteen should not operate the machine and should be kept away from where it is being used.

Safety warnings

The operator must read, understand and follow all of the Safety instructions. Serious injury or death may occur unless care is taken to follow the warnings and instructions provided. The level of safety is indicated in three levels indicated by the notations DANGER, WARNING & CAUTION – refer to the General Information page at the beginning of this manual for notation definitions.

⚠ DANGER

Never operate the tractor or machinery until you have read and completely understand this manual and the tractor operators manual and each of the safety messages found in the manuals and those displayed on the tractor and implement.

⚠ DANGER

DO NOT attempt any maintenance of or adjustment to the machine while it is running. Before carrying out any work on the machine follow the three safety instructions below:

- PUT THE PTO OUT OF GEAR
- STOP THE TRACTOR ENGINE
- LOWER THE CUTTING UNIT ON TO THE GROUND

⚠ DANGER

At all times ensure that the PTO shaft guard is in position, securely fitted and in good condition and that the tractor PTO shaft shield is fitted. Always replace any damaged guards and shields.

⚠ DANGER

Do not enter the working zone of the PTO shaft. It is dangerous to approach the rotating parts of the machine.

⚠ DANGER

Before maintaining and working on the machine always stop the tractor, switch off the tractor engine, remove the ignition key and remove the PTO shaft. Do not work under any machine raised on hydraulics unless it is supported by a solid safety support.

⚠ DANGER

Never clean or adjust PTO driven equipment with the tractor engine running. Kill the engine and pocket the key before attempting any maintenance on the machine.

⚠ DANGER All guards, bands, deflectors, driveline shields and gearbox shields should be used and maintained in good working condition at all times. They should be carefully inspected daily for missing or broken cable, chain links, shields or guards. Missing, broken or worn items must be replaced before attempting to use the machine to reduce the possibility of injury from thrown objects or entanglement.

⚠ DANGER Keep a careful watch for passers-by who may inadvertently get in the way of cut material being thrown from the machine. These machines are capable under adverse conditions of throwing objects great distances at high velocity. Stop the blades until all people are well clear.

⚠ DANGER **AVOID WIRE.** It can be extremely dangerous if wire catches in the blades of the machine, and every care must be taken to ensure this will not happen. Inspect the working area before commencing. Remove all loose wire and obstructions and clearly mark those that are fixed so that you can avoid them. Any unusual noise from the cutting unit area indicates that the blades may have been fouled by an obstruction. A visual indication that wire has become entangled may be a sudden movement of the vegetation ahead of the machine. In any such event **STOP** the tractor engine **INSTANTLY**. On no account move the machine until blades have completely stopped. **NEVER UNDER ANY CIRCUMSTANCES** run the machine in reverse to 'clear itself'. When the machine has stopped, inspect it and remove any obstruction that may be present. If working under a raised machine ensure that it is safely supported. Before working on the machine always stop the tractor engine and remove the ignition key.

⚠ DANGER **ANY UNUSUAL NOISE** from the cutting unit area indicates that the blades may have been fouled by an obstruction. A visual indication that wire has become entangled may be a sudden movement of the vegetation ahead of the machine. In any such event **STOP** the tractor engine **INSTANTLY**. On no account move the machine until blades have completely stopped. **NEVER UNDER ANY CIRCUMSTANCES** run the machine in reverse to 'clear itself'. When the machine has stopped, inspect it and remove any obstruction that may be present. If working under a raised machine ensure that it is safely supported. Before working on the machine always stop the tractor engine and remove the ignition key.

⚠ DANGER These machines are capable under adverse conditions of throwing objects great distances at high velocity. **CHECK** the blades for wear and the attachment bolts for tightness every day during work. A few moments whenever the machine is stopped (e.g. whenever removing obstructions) will help reduce blade wear or loss.

⚠ DANGER Do not operate with wings raised off the ground. Operating with the wings raised exposes the blades and can cause objects to be thrown and there is also danger of entanglement in or being hit by rotating blades.

⚠ DANGER Never transport the machine or attempt maintenance with the blades running. Serious injury or even death can result from contact with rotating blades.

⚠ DANGER Keep your forward speed to a level appropriate to the operating conditions. High-speed manoeuvres are very dangerous, particularly on uneven ground where there is risk of overturning.

- ⚠ DANGER** When the wings are folded for transport, the centre of gravity is raised and the possibility of overturn is increased. Turn slowly and with extra care on hillsides. Overturning the mower could cause the mower to overturn the tractor and vice versa. Never fold wings on a hillside, the mower may overturn
- ⚠ DANGER** Be particularly careful in transport. Turn curves or go up hills only at a low speed and at a gradual steering angle. Ensure that at least 20% of the tractor's weight is on the front wheels to maintain safe steering. Slow down on rough or uneven surfaces.
- ⚠ DANGER** DO NOT carry passengers on either the tractor or the mower - falling off can kill.
- ⚠ DANGER** Do not mount or dismount the tractor or machine while it is moving. Mount or dismount only when stopped – falling off can kill.
- ⚠ DANGER** Do not operate this Equipment with hydraulic oil leaking. Oil is expensive and its presence could present a hazard. **Do not check for leaks with your hand!** Use a piece of heavy paper or cardboard. High-pressure oil streams from breaks in the line could penetrate the skin and cause tissue damage including gangrene. If oil does penetrate the skin, have the injury treated immediately by a physician knowledgeable and skilled in this procedure.
- ⚠ DANGER** Never leave the machine in the raised transport position – the machine could fall inadvertently and cause injury or death to anyone who might be under the machine.
- ⚠ DANGER** Never run a tractor engine in a closed building without adequate ventilation. The exhaust fumes can be hazardous to your health.
- ⚠ DANGER** Never work under the mower deck, framework or any raised component unless the mower has been securely supported and blocked using suitable substantial items to prevent sudden or inadvertent falling which could cause serious injury or even death.
- ⚠ DANGER** Operate the mower only with a tractor equipped with an approved 'roll over protection system (ROPS). Always wear your seat belt. Serious injury or even death could result from falling off the tractor – particularly during a turnover when the operator could be pinned under the ROPS or the tractor.
- ⚠ DANGER** The rotating parts of this machine have been designed and tested for rugged use. However, they could fail upon impact with heavy solid objects such as steel guardrails and concrete abutments. Such impact could cause the broken objects to be thrown outward at very high velocities. To reduce the possibility of property damage, serious injuries, or even death, never allow the cutting blades to contact such objects.

! WARNING Before starting, checks on both tractor and machine must be carried out with regard to: functionality, road safety, accident prevention rules.

! WARNING Before leaving the tractor stopped with the machine attached, proceed as follows: Disconnect the power take off, lower the machine steadily to the ground (with the hydraulic lift). Apply the hand brake and, if the ground is steeply sloping, wedge the tractor. Take out the starting key. Immediately replace any safety sign, or any missing or damaged decal.

! WARNING CHECK the blades for wear and the attachment bolts for tightness every day during work (see Maintenance section). A few moments whenever the machine is stopped (e.g. whenever removing obstructions) will help reduce blade wear or loss.

! WARNING Do not transport unless wings are well secured in the transport position. Wings that are not well secured can fall during transport, causing serious damage to the tractor and mower and possibly causing the operator or passers-by to be injured or killed.

! WARNING During checks or repairs, make sure nobody could start the machine by mistake.

! WARNING Ensure only one person operates the machine at any one time.

! WARNING Missing or damaged guards must be replaced immediately.

! WARNING Blades will continue to rotate for some time after the tractor PTO has stopped.

! WARNING Extreme care should be taken when operating near loose objects such as gravel, rocks, wire, and other debris. Inspect the area before mowing. Foreign objects should be removed from the site to prevent machine damage and/or bodily injury or even death. Any objects that cannot be removed must be clearly marked and carefully avoided by the operator. Stop mowing immediately if flails strike a foreign object. Repair all damage and make certain the rotor shaft is still balanced before resuming cutting operations. NOTE: Where grass and weeds are high enough to obscure debris that could be struck by the blades, the area should be inspected and debris removed, mowed at an intermediate height, and re-inspected closely to remove any remaining debris and mowed again at the desired final height. In addition to the safety aspect of this procedure it will also reduce wear and tear on the mower drive-train, spread cut materials better, eliminate 'streaking' and make the final cut more uniform.

! WARNING Never attempt to lubricate, adjust, or remove material from the machine while it is in motion or while tractor engine is running. Make sure the tractor engine is off before working on the Implement.

! WARNING Never connect the power take off unless the tractor engine is stopped.

! WARNING When unhitching the mower select a firm level site on which to park it - lower machine to the ground fully (fit and adjust the hitch support prop on high hitch machines) and 'chock' the wheels. Remember to disconnect hydraulics, lighting plug and PTO shaft (use the PTO support) before

driving the tractor away. Stow hoses and electrical cable neatly off the ground to avoid moisture or dirt contamination.

! WARNING For machines fitted with hitch adjustment mechanisms, never un-couple the machine without using the hitch support jack. The hitch is very heavy. Attempting to lift the hitch without using the jack could cause strains. Allowing the hitch to fall suddenly and unexpectedly could result in crushing injury. Use the support jack for lifting the mower only. Overloading the jack can cause failure with possible serious bodily injury or even death.

! WARNING Periodically inspect all moving parts for wear and replace when necessary with authorised service parts. Look for loose fasteners, worn or broken parts, and leaky or loose fittings. Make sure all pins have cotter pins and washers. Serious injury may occur from not maintaining this machine in good working order.

! WARNING Where hydraulic rams are fitted, release hydraulic pressure from the rams before attempting maintenance. Lower the machine to the ground and lower any wings or securely block them up, disengage the PTO and turn off the engine.

! WARNING The operator and all support personnel must wear appropriate Personal Protective Equipment: i.e. safety clothing, safety glasses and protective footwear at all times for protection from injury by objects thrown from the machine.

! WARNING Transport the machine only at safe speeds. Serious accidents and injuries can result from operating this equipment at unsafe speeds

! WARNING While the tractor is running all personnel should keep well clear of the area around the machine as there are numerous crushing, shearing, impact dangers caused by the machine operation.

! WARNING Beware of dust. Keep tractor cab windows and doors closed at all times to reduce the risk of dust and flying debris from entering. In dusty conditions the use of a suitable mask, to EN 149, is strongly recommended.

! WARNING The machine must only be lifted by personnel with appropriate lifting qualifications. The lifting points are clearly marked with 'hook' symbols.

! WARNING Always ensure the tractor front end weight is sufficient to give proper front wheel contact and safe steering when machine is raised on tractor hydraulics.

! WARNING The operator's manual must be kept with the machine to be available for quick and easy reference.

! WARNING Beware of bystanders and animals. Before starting the tractor engine and moving off, check that it is safe to do so. Never operate the machine with bystanders or animals near or on the machine or tractor. Never stand in or walk through the flow of any material being discharged. Never stand between tractor wheels and the machine.

! WARNING Do not start or carry out maintenance on this machine until you have read all the safety precautions to be observed and until you fully understand the controls and functions of the machine as detailed in the following sections. If you do not understand any part of this manual, ask your dealer for assistance.

! WARNING Always fit the PTO shaft guard & check chains. P.T.O. guard check chains must always be attached to a suitable point on the tractor and machine to prevent movement of the outer plastic shields.

! WARNING It is the owner's/operator's responsibility to ensure that the machine is fitted with correct lighting and safety markings when moving it on the public highway during the hours of darkness.

! WARNING Never operate the machine with any of the rotor blades missing or damaged. To prevent injury when changing the blades, always block the rotor to stop it rotating.

! WARNING Never operate the machine with any parts missing. Check the machine regularly for loose or damaged parts. Pay particular attention to the condition of all safety guards. Always use the manufacturer's genuine replacement parts in the interest of safety. Failures caused by the use of unapproved replacement parts will not be covered by our warranty, nor will any liability be accepted for damages or injury thus incurred.

! WARNING Never stand on the machine, attempt any maintenance or adjustments with the tractor engine running or P.T.O. shaft connected.

! WARNING Never wear loose fitting or ragged clothing. Avoid injury - always wear clothing which cannot get caught in machinery.

! WARNING Before leaving the tractor seat always engage the brake and/or set the tractor transmission in parking gear. Disengage the PTO, stop the engine, remove the key and wait for all moving parts to stop. Place the tractor shift lever into a low range or parking gear to prevent the tractor from rolling. Never mount or dismount a moving tractor. Operate the tractor controls from the tractor seat only.

! WARNING Ensure all necessary signs are correctly displayed, and clearly visible, when working or transporting on or near a public highway (*Contact your Local Highway Authority to ensure you are fully conversant with your responsibilities on this subject*). Use flashing warning lights when working or transporting on or near a public highway to indicate to other road users a potential hazard. Always abide by local traffic regulations.

! WARNING Ensure the machine is regularly inspected for loose fasteners, worn or broken parts and loose or leaky fittings. Ensure all pins are fitted with cotter pins and washers. Serious injury can result from failure to maintain this machine in good working order.

! WARNING Ensure you maintain all safety decals in good readable condition. If a decal should for any reason become illegible order a replacement immediately before permitting the machine to be used.

⚠ CAUTION Both the operator and the maintenance fitter must know the machine well, especially regarding dangers resulting from improper use or incorrect repairs.

⚠ CAUTION In transport, reduce speed, especially on bumpy roads.

⚠ CAUTION When driving on public roads, respect all road rules in force.

⚠ CAUTION The manufacturer will not be held responsible for failure caused by the use of incorrect lubricants. For further information, refer to the lubrication section of this manual.

⚠ CAUTION Pay special attention when working with the machine, not to touch fixed objects, such as road drain, walls, shafts, kerbs, guard rails, tracks etc. This could cause damage to blades and cause debris to be thrown out at very high speed.

⚠ CAUTION If wires, ropes or chains should get entangled in the blades, stop immediately, to prevent damage or dangerous situations; stop the blades and the tractor, take out the ignition key. Put working gloves on; clear the blades with the aid of pliers or shears.

⚠ CAUTION Ensure hydraulic pipes are carefully and correctly routed to avoid damage by chaffing, stretching or pinching and that they are held in place with the correct fittings.

⚠ CAUTION Always follow the manufacturer's instructions for attachment and removal of the machine from the tractor.

⚠ CAUTION Check that the machine fittings and couplings are in good condition.

⚠ CAUTION Ensure the tractor meets the minimum weight recommendations of the machine's manufacturer and that ballast is used as necessary.

⚠ CAUTION Use clear suitably sized warning signs to alert others to the nature of the machine working within that area. Signs should be placed at both ends of the work site. (It is recommended that signs used are of a size and type specified by the Department of Transport and positioned in accordance with their, and the Local Highways Authority, guidelines).



Emergency Stopping

In an emergency bringing the blades to a stop requires familiarity with the controls fitted to the tractor.

To stop the blades in an emergency use the tractor 'ENGINE STOP' control. **NOTE: The use of the tractor 'ENGINE STOP' control must only be done in an emergency.** Its use to stop the machine can cause damage. After an emergency stop of the machine; ensure that the PTO is disengaged before restarting the tractor.

Dangers due to Overhead Power Lines (OHPL's)

There are significant dangers involved when working in the vicinity of Overhead Power Lines;

⚠ DANGER All operators must read the following information and be aware of the risks and dangers involved when working in the vicinity of Overhead Power Lines (OHPL's).

⚠ WARNING Fatal electrocution can occur without contacting a power line. Due to the high electrical potential between the conductors and the ground a flash over can occur from the power line to any conducting medium within range. Steel mowers are ideal conductors.

Wherever possible the safest option is always to avoid working in areas close to OHPL's. Where unavoidable, all operators must perform a risk assessment and implement a safe procedure and system of work, *refer to risk assessment section below*.

All operators should perform a risk assessment before operating any arm mower within 10m horizontal distance of any OHPL's. If you are unsure do not work in the area. Never put yourself or others at risk.

Risk Assessment

Before starting to work near OHPL's you should always assess the risks. The following points should be observed;

- **Know** the risks of contacting OHPLs and the risk of flashover.
- Always **find out** the maximum reach height for your machine mounted on its tractor, refer to machine general specification section for guidance.
- Always **find out** the location and route of all Power Lines within the work area.
- Always **find out** the operating voltage of all Power Lines within the work area.
- Always **contact** the local Distribution Network Operator (DNO) who will be able to advise you on the operating voltage, exclusion zones, the minimum safe working distance and any additional precautions required.
- **Never** attempt to operate the machine within an exclusion zone.
- Always **work with extreme caution and plan your work ahead** to avoid high risk areas.
- **If doubt exists** do not work in the area – never risk the safety of yourself or others

Further information and leaflets on this and other agricultural safety subjects are available on the 'Health & Safety Executive' website at the following address: www.hse.gov.uk/pubns/agindex.htm

Emergency Action for Accidents Involving Electricity

- Never touch an overhead line - even if it has been brought down by machinery, or has fallen. Never assume lines are dead.
- When a machine is in contact with an overhead line, electrocution is possible if anyone touches both the machine and the ground. Stay in the machine and lower any raised parts in contact or drive the machine out of the lines if you can.
- If you need to get out to summon help or because of fire, jump out as far as you can without touching any wires or the machine keep upright and away.
- Get the electricity company to disconnect the supply. Even if the line appears dead, do not touch it - automatic switching may reconnect.

Minimum Heights for Overhead Power Lines

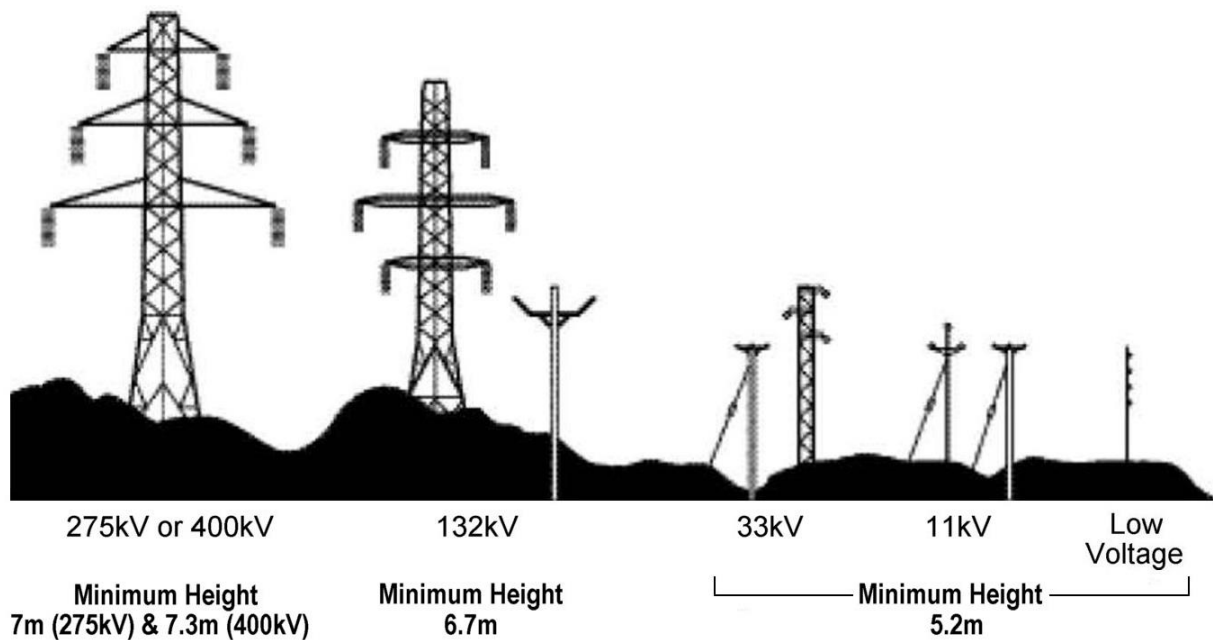

Absolute Minimum Exclusion Zones for Specific Overhead Power Lines

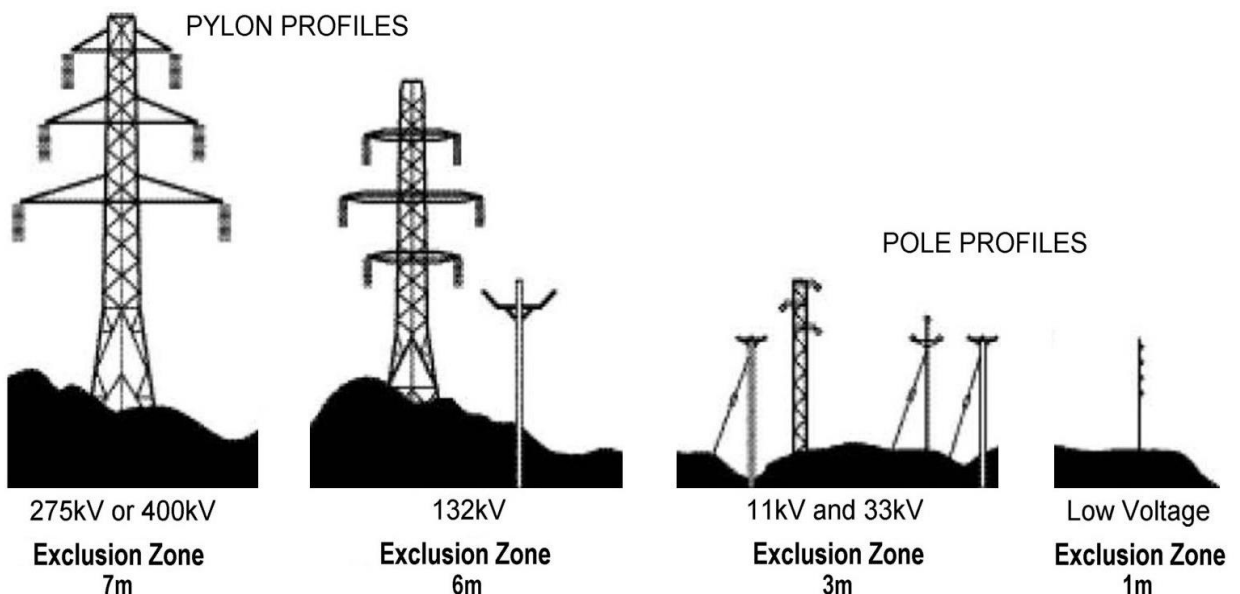

Definitions of Exclusion Zones

EXCLUSION ZONES ARE SHOWN AS SHADED

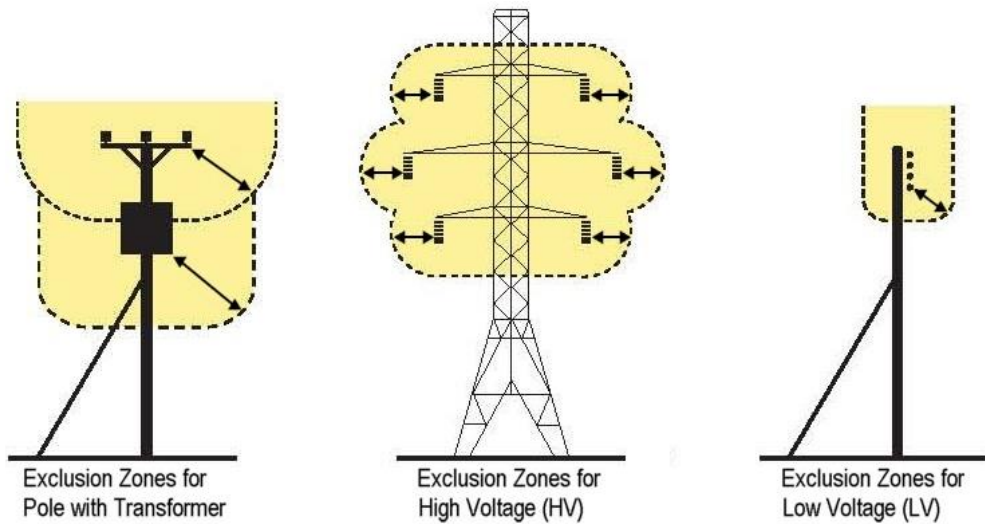

Noise

The equivalent daily personal noise exposure from this machine, measured at the operator's ear, is within the range of 80-85dB when used in conditions where the load fluctuates between zero and maximum. This applies when the machine is attached to a tractor fitted with a quiet cab and used in accordance with the operating instructions in a generally open environment. At equivalent daily noise exposure levels of between 85 and 90dB, suitable ear protectors are recommended.

Personal Protective Equipment



When working in an unsealed cab or where windows and apertures are open to the environment, operators are advised to wear suitable ear protectors.



When handling cutting surfaces or hydraulic equipment, operators are advised to wear suitable gloves.



When clearing blockages, clearing wire, or working with pressurised hydraulic components, operators are advised to wear suitable eye protection.



When working at the work site, but off the tractor unit, operators are advised to wear a 'high-viz' garment.

Guards

⚠ DANGER For safe operation it is essential that that all guards must be kept in position on the machine whenever the machine is running.

The manufacturer / supplier disclaim all responsibility for any damage or injury arising as a result of guards being removed, or of guards other than those of the manufacturer having been fitted, or of operation of the machine other than in accordance with these instructions.

⚠ WARNING Inspect guards twice daily or immediately damage is suspected. Always replace guards that have damage or wear which could impair their performance

⚠ WARNING Ensure that the blades and all fixings are genuine components supplied by the manufacturer specifically for the machine and are securely attached with no parts missing or damaged.

Tractor stability

Due to the design of mowers and the work they undertake, it is essential to ensure that the tractor is stable during work and transport in order to eliminate any risk of loss of directional control, imbalance or overturning.

Before driving in transport, check that the front wheels of the tractor are both on the ground. It is advisable to have a helper to check this. Check that the tyre shows evidence of bearing load. This is especially important to ensure forward directional control at speed on an undulating terrain.

If the front tyres lift add ballast weights to the front of the tractor. If ballast weights have been added to the tractor, check that the plated tractor axle loads have not been exceeded.

⚠ DANGER Keep your forward speed to a level appropriate to the operating conditions. High-speed manoeuvres are very dangerous, particularly on uneven ground where there is risk of overturning.

⚠ DANGER When the wings (if fitted) are folded for transport, the centre of gravity is raised and the possibility of overturn is increased. Turn slowly and with extra care on hillsides. Overturning the mower could cause the mower to overturn the tractor and vice versa. Never fold wings on a hillside, the mower may overturn.

⚠ DANGER Be particularly careful in transport. Turn curves or go up hills only at a low speed and at a gradual steering angle. Ensure that at least 20% of the tractor's weight is on the front wheels to maintain safe steering. Slow down on rough or uneven surfaces.

⚠ DANGER Operate the mower only with a tractor equipped with an approved 'roll over protection system (ROPS). Always wear your seat belt. Serious injury or even death could result from falling off the tractor – particularly during a turnover when the operator could be pinned under the ROPS or the tractor.

⚠️ WARNING Failure to have sufficient load over the front axle or to drive at inappropriate speeds on undulating terrain may result in a loss of directional control.

⚠️ WARNING Transport the machine only at safe speeds. Serious accidents and injuries can result from operating this equipment at unsafe speeds

⚠️ WARNING Always ensure the tractor front end weight is sufficient to give proper front wheel contact and safe steering when machine is raised on tractor hydraulics.

⚠️ CAUTION In transport, reduce speed, especially on bumpy roads.

NOTICE When transporting on the highway, it is the responsibility of the operator to obey all relevant local highway laws.

Working on Inclined Ground

The ballast instructions stated above are sufficient for level ground operation.

Be aware that when working on inclined ground changes in the tractor centre of gravity can adversely affect the overall stability.

There is naturally a limit to a safe amount of ballast compensation that can be applied for a given tractor unit and a given incline. If compensating ballast is applied and the compensated axle must be driven on the public highway to reach the work site the operator should ensure that the plated axle load is not exceeded.

Remember, a mower represents a significant mass which can generate a significant amount of inertia when moved at speed. Stopping this inertia suddenly can induce overturning reactions.

⚠️ DANGER When working on inclined ground avoid any high speed hydraulic manoeuvres which could cause overturning.

Working on Embankments

Sudden potholes at speed can quickly cause the tractor to change direction. At the same time the weight of the implement may try to lift the front axle. This is a potentially lethal combination when working along narrow embankments or dykes and can lead to overturning and potential drowning.

When working on top of embankments it is very important to have sufficient forward stability to ensure rapid steering control. We recommend 20% forward stability. This means that at least 20% of the total vehicle weight is acting on the steering axle under normal level conditions.

⚠️ DANGER When working on raised embankments ensure sufficient weight is on the steering wheels.

Safety Decals

Safety decals are located on various points of the machine. To identify the correct location refer to the serial number specific Parts Manual. Safety decals can be identified by the yellow upper panel depicting the hazard, and the lower white panel indicating means of avoidance or precautions to be taken. These decals have no text. It is essential that all operators and personnel associated with the machine fully understand safety decal meanings; these are shown below.

Safety decals should be kept clean and legible at all times. Any safety decals which are found to be missing or illegible should be replaced.

In addition to the safety messages stated here the machine is fitted with warning decals that are designed to bring to the attention of the operator the potential dangers that exist whilst using the machine. However, these cannot replace correct proper training and total awareness of all the dangers involved in using a machine of this type, and the nature of the work it does.

BE ALERT, PAY ATTENTION – SOMEONE’S LIFE MAY BE AT STAKE!

Safety Decals Identification & Meaning



Read and Comply with Operator's Manual

Read and understand the Operator's Manual before attaching and operating this machine.



Stop Tractor before Working on Machine.

Always let the tractor come to a stop, and remove the starter key before you adjust, lubricate, repair or carry out any maintenance work on the machine.



Keep a Safe Distance from the Machine.

Danger of flying objects when machine is working. Bystanders must keep a safe distance when the machine is being used.



Beware of Rotating Blades.

Danger of cutting or severing of limbs under covered rotating parts. Do not reach or probe under the machine when it is driven by the tractor.



Machine Lifting Points.

When lifting the machine with other than approved tractor attachment points, use the marked lifting points for safe and balanced lifting.



Input PTO Speed.

The rated PTO speed for this machine is 540 rpm. For optimum performance, the machine should be driven at this speed. Under no circumstances should this speed be exceeded.



Danger of entanglement.

Keep clear of machine when in operation.



Danger of entanglement

keep clear of machine when in operation.



Keep all nuts tight



Do not work under unsupported machine.



Danger of crushing stay clear of zones



Danger Do not operate machine when raised.



Cut height setting in millimetres

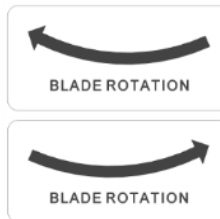

Blade rotation direction indicator decals

IMPORTANT
Time Blade Carriers
Perpendicular To
Each Other



MACHINE PREPARATION

Unpacking the Machine

Check that the machine instruction manual is located in the document holder attached to the machine.

The operator's manual should be regarded as part of the machine. Suppliers of both new and second hand machines are advised to retain documentary evidence that this manual was provided with the machine. Check that the serial number has been entered inside the front cover of this manual. Add it appropriately if necessary. The serial number is stamped on the main deck mower adjacent to the linkage mounting. Always quote these numbers in any correspondence with a dealer.

Lifting the Machine

⚠ WARNING Only personnel experienced in lift and hoist operation should be involved in lifting machines.

The approved lifting points are illustrated in the machine general specification section under 'machine description'. Check that the correct lifting points are used to suit the machine's configuration, as the centre of gravity will change if for example a side shift position or wing deployment position is different per lift. - Exercise caution!

Use only the approved lifting points shown, and marked on the machine with the lifting decal illustrated opposite. Ensure any lifting equipment used has a 'Safe Working Load' (SWL) of 1.5 tonnes minimum.



⚠ WARNING Only use approved lifting equipment which is correctly fastened to the machine - this will increase your personal safety. Failure to follow the safety instructions could result in accidents and serious injuries.

⚠ WARNING Before attempting to access the underside of the machine, ensure it is adequately and safely supported. Do not rely on the tractor's hydraulics. Use safety supports that have a minimum Safe Working Load (SWL) of 1.5 tonnes.

On despatch from the factory the rotors and blades of the machine will be secured with restraining wires and/or cable ties to stop them moving during delivery; **these restraining wires must be removed before using the machine.**

Locate and remove the 'Power Take-off Shaft' (PTO) from its shipping position, and temporarily store it in a place of safety. If fitted, remove the stacking transport legs. See *illus. a)* below.

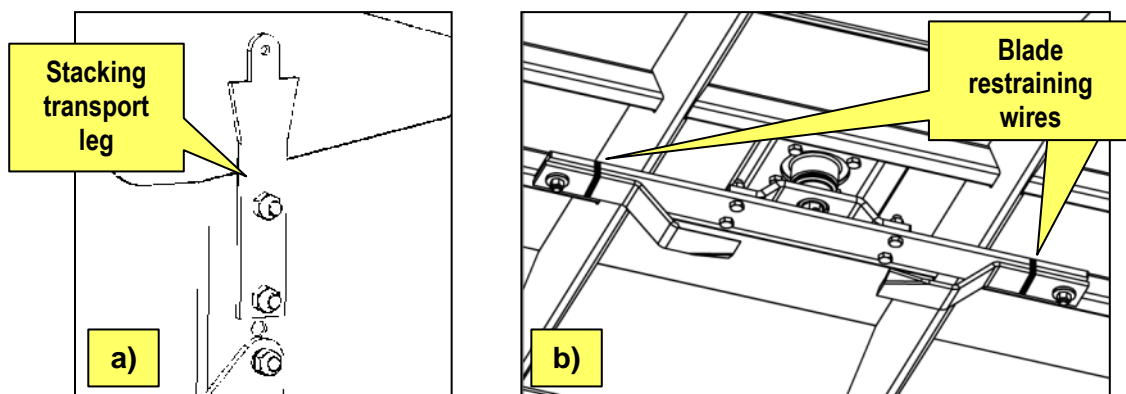

With the machine suitably supported, remove all rotor and blade restraining wires and/or ties, see *illus. b)* above. Inspect the underside of the machine to ensure it is undamaged, and check all blades rotate freely and do not foul on the body.

Tractor Preparation

⚠ WARNING

Ensure that all operators have read and thoroughly understood all the safety procedures. For further information refer to the relevant sections of this manual.

⚠ WARNING

When connecting the machine to a tractor there is a risk of personal injury. Failure to follow the safety instructions could result in serious injuries to either yourself or others. Therefore, when connecting the machine and the tractor you should:

- Make sure the tractor cannot roll.
- Make sure that the tractor and the machine have compatible category attachments.
- Never stand between the tractor and the machine during attachment.
- Use the hydraulic three point linkage slowly and carefully.
- When carrying out an attachment you must make sure that the machine is placed on a firm and level surface.

Tractor Requirements

Before fitting the machine to the tractor ensure that the specification of the tractor meets the requirements listed below.

- Tractor has a PTO output shaft which conforms to the machine's specification.
- Tractor has a PTO output speed which conforms to the machine's specification.
- A tractor top link is available, *if required*.

Once the machine has been mounted to the tractor unit check the following;

- The correct amount of fore/aft stability ballast has been added to the tractor front weight tray. The amount will vary depending on type of tractor used and prevailing conditions.
- The correct amount of lateral stability ballast has been added to the rear wheel opposite to the side shift movement (*if available*). The amount will vary depending on type of tractor used and prevailing conditions. NOTE: In some cases, machines are capable of being deployed on both sides of the tractor, where this applies lateral ballast may be required on both rear wheels.
- Once the machine is mounted to the tractor and the tractor is correctly ballasted ensure that the maximum axle loads for the tractor have not been exceeded. Failure to meet this requirement may render the operator liable for infringement of public highway regulations.
- Ensure that the tyres fitted to the tractor are correctly rated for the total working weight. NOTE: When the cutting unit is fully side shifted the load on the rear tyre on the cutting side increases.

The use of water ballast within tyres cannot be endorsed as this can have adverse effects on fore aft stability at speed.

Check the run of the PTO for clearance. If necessary remove the tractor drawbar or position it to one side so it does not foul on the PTO shaft. Redeploy or remove any items which are likely to contact the PTO in operation.

The machine is connected to the tractor on the 3 point hitch, and will accept either CAT I or CAT II linkages. The tractor must also be equipped with a levelling box. If the tractor is fitted with a swinging drawbar, this should be set in its shortest mode or removed completely. The tractor should be equipped with a six-splined PTO.

Attaching the Machine

Attachment of the machine should be performed on a firm level site - the procedure for attachment is as follows;

A-Frame Mount Models

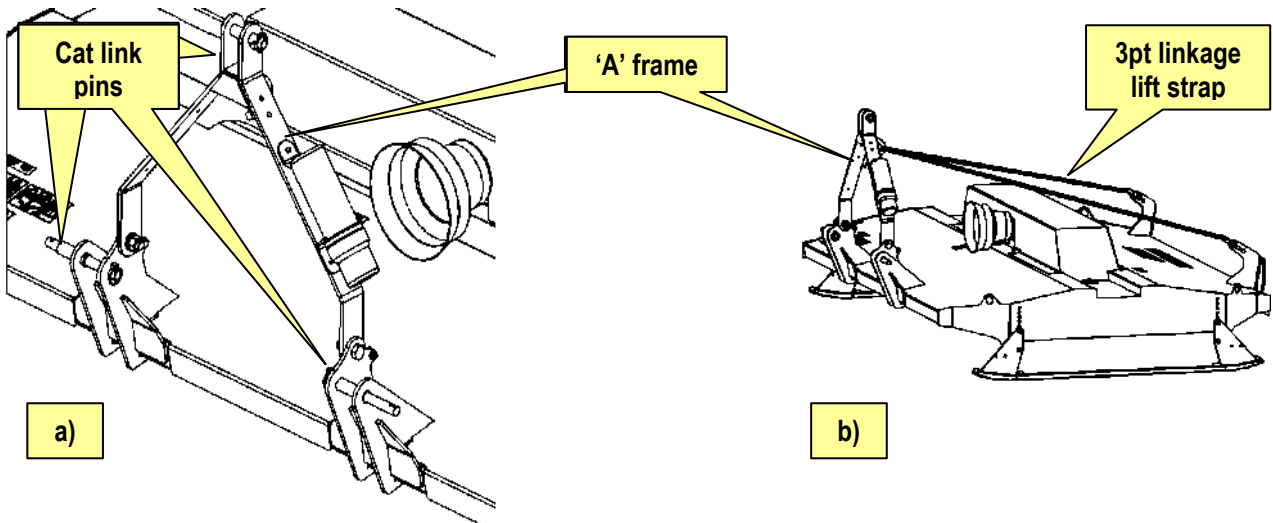

Headstock Mount Models

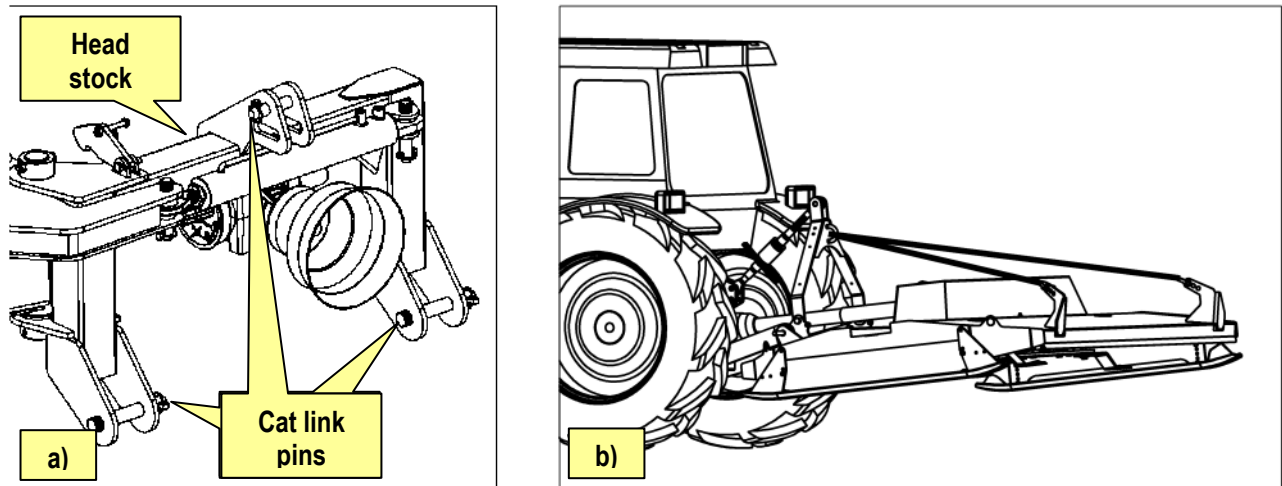

Attachment Procedure

- Remove or reposition any tractor drawbar so it does not foul on the PTO shaft.
- Remove the two Cat. I / Cat. II Link Pins, and the Top Link Pin – *refer to illustrations a) above*. If necessary support the 'A' frame whilst doing this.
- Reverse the tractor up to the machine, and adjust the lift arm height to align with the pin holes. Turn off the tractor, apply the parking brake and remove the starter key.
- Attach the lower lift arms to the machine using the Cat I / Cat II pins.
- Adjust and attach the Left Hand Lift Arm using the tractor Levelling Box if necessary.
- Refit the lynch pins.

For 'Headstock' mounts:

- Adjust the length of the tractor top link and attach it to the single hole in the top of the 'headstock'.

For 'A-Frame' mounts:

- Raise the 'A' frame and fit the top link. Adjust the length of the link to remove any slack and add tension to the transport strap, without lifting the rear of the machine off the ground.

- Start the tractor and raise the machine on the lift arms until the gearbox PTO shaft of the machine and the tractor PTO are at their shortest distance apart.
- Turn off the tractor, apply the parking brake and remove the starter key.
- Adjust the tractor stabiliser chains (or bars) so there is no lateral movement when the machine is in the raised position.
- If fitted, remove the parking leg securing pin. Lift the parking leg, and replace the pin in the leg lower hole so that the parking leg clears the ground.
- Identify the end of the PTO containing the shear bolt and connect this end to the machine. Fasten the guard check chain securely.
- Connect the other end of the shaft to the tractor, once again securing the guard 'check chain'.
- With the PTO shaft correctly connected, raise the machine to a safe transport position. Ensure a clearance of at least 100mm between the underside of the shaft and the body of the machine whilst in the transport position.
- Lock the 'lift arm stop' in this position.

⚠ CAUTION Raising the tractor lift arms too high may cause damage to the PTO shaft if the tractor was to drive over any bumps and the machine was to bounce on the lift arms.

- Check that there is no lateral movement on the machine when it is in the raised position; adjust the stabiliser chains/bars if required.
- On the first occasion when the machine is fitted to a tractor the PTO shaft may need adjusting in length, refer to PTO shaft installation section for details. *Bear in mind that using the machine on another tractor at a later date may necessitate further adjustments or the fitting of a new, longer shaft.*
- If fitted, connect the Hydraulic Hose fittings to the Tractor Spool Valve. Refer to the tractor operator manual.
- If a side shift function is available, locate the transport latch release rope, and attach it to a convenient point on the rear of the tractor within easy reach of the cab. Ensure the rope will not become entangled with any operational moving part.

⚠ WARNING Read all the safety instructions carefully before driving on the public road and always comply with the local law concerning lights, warning and safety signs. The driver and/or the owner of the machine have the responsibility of complying with the local Road Traffic Acts.

Always ensure tractor manoeuvrability is not adversely affected by any attached machinery; the steering axle of the tractor should be loaded with at least 20% of the tractor and cutting implement's combined dead weight. See Safety section.

⚠ DANGER The carrying of passengers on the machine is strictly prohibited.

Setting the Cutting Height

⚠ WARNING Before attempting to access the underside of the machine, ensure it is adequately and safely supported. Do not rely on the tractor's hydraulics. Use safety supports that have a minimum Safe Working Load (SWL) of 1.5 tonnes.

Undo the side skid attachment bolts and using the cut height decal reposition the side skids at the desired cut height, *refer to illustration below.*

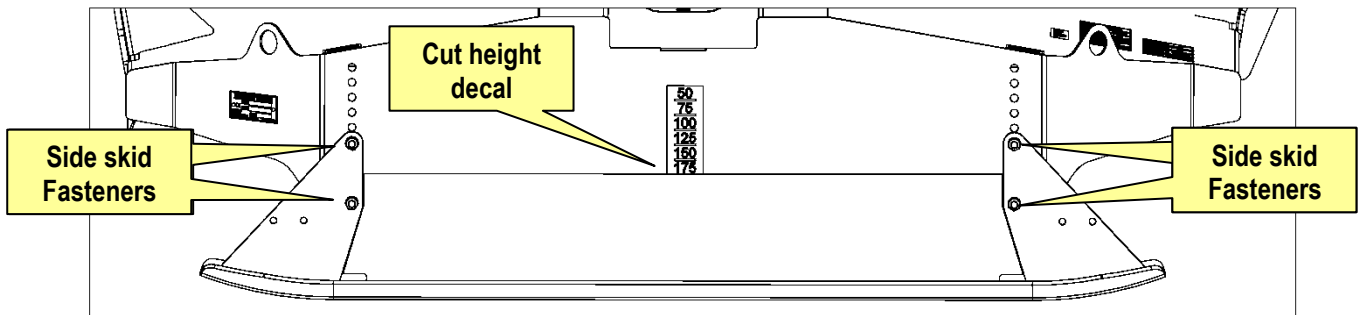

⚠ WARNING Take care to ensure that both skids are set at the same height.

If your machine is equipped with folding wings or, decks mounted on deployment arms, make sure that each deck is level and parallel to the ground. Failure to 'set' the machine for level cutting will result in an uneven cut height.

PTO Driveshaft Installation

The PTO driveshaft attaches between the tractor and the machine gearbox to transfer the power required to run and operate the machine – it is important to achieve the correct shaft length to avoid risk of it 'bottoming out' when raising or lowering the machine.

Due to many different makes and sizes of tractor to which mowers may be fitted, a nominal length PTO shaft is supplied with the machine. In some cases the nominal PTO shaft supplied will be too long and will have to be shortened, *see below.*

NOTICE The recommended minimum engagement of the PTO is 150mm in the working position. This measurement must be taken into account when shortening the PTO shaft. *See shortening PTO length section for details.*

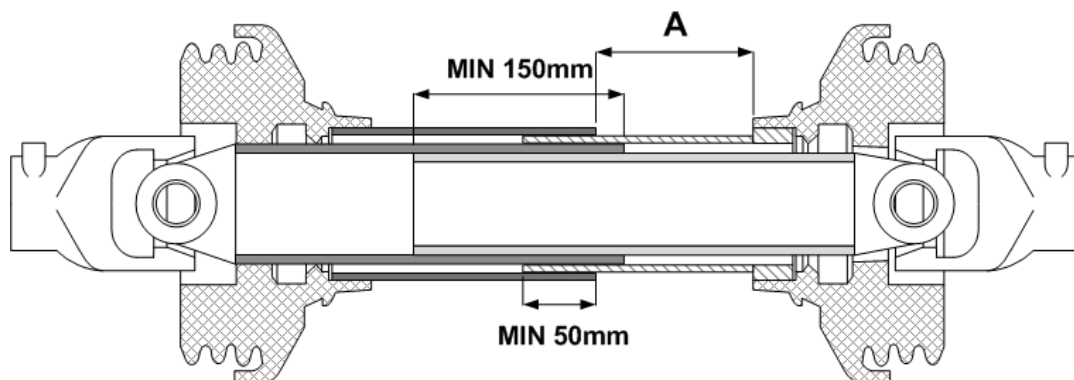

Shortening PTO Length

- Both machinery and tractor must be parallel to one another.
- Pre-assemble the PTO shaft and check that the drive tube overlap is not less than 150mm, refer to illustration a) below.
- Check that the minimum overlap of the shaft guards is not less than 75mm, see illustration above.
- If the overall PTO length is likely to reduce during operation then ensure that at its minimum there is at least 40mm movement left between the guards, see dimension 'A' in the illustration above.
- If the PTO needs to be shortened, cut both tubes as both halves must be shortened equally, see illustration b) below.
- Remove burrs with a file and clean any residual cutting debris from the tubes.
- Before fitting the PTO shaft to the tractor, grease the sliding drive shafts and bearing units.
- Fit the PTO to the tractor ensuring that the locking peg and collar on the spline-coupling is fully engaged.
- Attach the PTO guard check chains to the tractor and to the machine to prevent guard rotation.

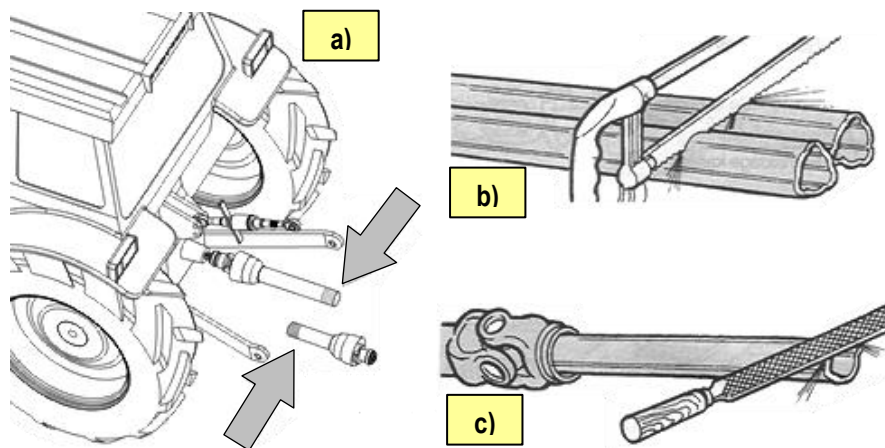

PTO Maintenance

To increase the working life of the PTO shaft it should be periodically checked, cleaned and lubricated – refer to the manufacturer's manual provided with the shaft for further details on this subject.

LUBRICANTS

Approved Lubricants

⚠ WARNING Only use oil on the approved list shown below.

SUPPLIER	OIL
BP	Energear Hypo 80W-90 EP
Castrol	Multitrax 80W/140 EPX 80W/90 EPX 85W/140
STAT Oil	Gearway G4 80W-90
Q8	Q 8 T 55 80W/90
Mobil Oil	Mobilube HD 80W/90
Shell	Spirax HD 80W/90
Texaco	Geartex EP-C 9-W/90
OK	OK Gearoil GL 5 80W/90
Hydro	Hypoid Gearoil 80W/90

Filling the Gearbox

Oils conforming to SAE 90EP are recommended for all gearboxes. Always check the oil level before use and top up if necessary.

The gearbox capacities for twin blade machines are detailed below;

MACHINE TYPE	GEARBOX	CAPACITY (Litres)
PT180 Topper	90° Blade Drive Box	1.1
PT240 Topper	Drive 'Tee' Transfer Box	1.2
	90° Blade Drive Box	1.1
PT240 Offset Topper	Drive 'Tee' Transfer Box	1.2
	90° Blade Drive Box	1.1
	'Tee' Blade Drive Box	1.1
PT270 Topper	Drive 'Tee' Transfer Box	1.2
	90° Blade Drive Box	1.1

Greasing Pivot Points

Any lithium based grease can be used for lubricating pivot points.

INSTALLATION CHECKS

After the machine has been attached to the tractor for the first time, it should be tested to ensure it operates correctly before putting it to work.

Initial Run-Up

Use the following procedure when running the machine for the first time.

- Lower the machine so the skids are resting on the ground, and the machine is level.
- With the tractor at low revs, gently engage the PTO until the machine is running.
- Carefully increase the PTO speed to 540 rpm.
- Check that the machine runs smoothly and without vibration.
- Raise the machine to top of lift arm travel.
- Check again that the machine runs smoothly and without vibration.
- Lower the machine to ground level again.
- Gently reduce the tractor revs to idle, and disengage the PTO.
- Apply the parking brake and stop the tractor.

If any faults are identified, refer to 'Trouble Shooting' section. If a solution is still not found, consult your local dealer for assistance.

Checking Head Float

All machines have head float fitted as standard. Head float allows the cutting unit to pitch fore - aft around the lower link pins, smoothing out undulating ground. To check the head float operation for;

PT180 Model

Adjust the top link to slacken off the transport strap to allow approximately 50.0 mm of play when the machine is lowered onto the skids on a level surface, *refer to illustration a) below.*

PT240 Model

Adjust the top link to slacken off the transport strap to allow approximately 50.0 mm of play when the machine is lowered onto the skids on a level surface, *refer to illustration a) below.*

PT240 Offset Model

Remove the Top Link pin from the single hole on the headstock, and reposition it through the slot directly below, *refer to illustration b) below.*

PT270 Model

Adjust the top link to slacken off the transport strap to allow approximately 50.0 mm of play when the machine is lowered onto the skids on a level surface, *refer to illustration a) below.*

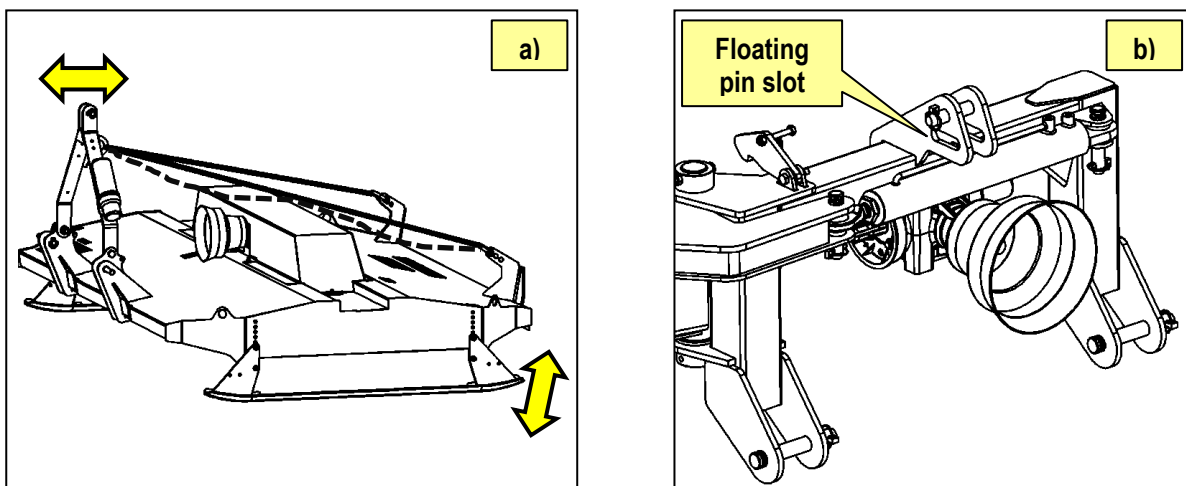

Breakout Checks (if fitted)

All breakout systems are designed for the purpose of providing initial protection to the mower and its cutting attachment. This protection is to be afforded in the relatively rare circumstance that an obstruction; unseen by the operator; is encountered during work.

Breakout systems are not designed as a complete protection system to remove operator responsibility. The operator must always be in control. By breaking back the arm signals to the operator that an obstruction has been encountered or that the operator is driving too fast for the cutting conditions. It is then the responsibility of the operator to take appropriate action to prevent any further damage to the arm mower. Damage resulting from continuing to work with the arm 'broken back' will invalidate warranty claims.

In most cases the speed of response required by the operator is proportional to the cutting speed. Operators must therefore work responsibly and appropriately for the cutting conditions and within their own individual capability.

Take time to familiarise yourself with the breakout supplied with your machine. Make sure you are familiar with its capability before commencing work.

Hydraulic Hose Checks

It is important that hoses are fitted correctly. Always check all hoses to ensure that there are no kinks or sharp bends, and that the hoses do not chafe against sharp edges. The following guidelines should be used when checking the hosing of the machine prior to work;

Twists

Hoses should never be twisted or kinked. On most hoses there is a line which runs the full length of the hose acting as a useful guide. If a visual check reveals that no guideline is present along a hose, conduct the following checks;



- Loosen any clamps.
- Attach one end of the hose to its coupling, but do not tighten.
- Place the hose in its required position.
- Connect the other end loosely to its union.
- Tighten the end with any angled fittings first ensuring it is in the right position for its intended run.
- Now tighten the straight end. It is possible that as the nut is tightened the hose may twist slightly.
- If this happens, slacken off the nut and turn the hose in the opposite direction to that caused by tightening. Then, re-tighten the nut bringing the hose back to the central position.
- Otherwise tighten the fitting fully. *Torque settings for both BSP and Metric hose fittings are listed on the following page.*
- Tighten any clamps.
- Finally re-bleed the rams and operate the arms in all positions whilst carefully checking for any twists and obstructions.

Sharp Bends

Hoses should always be fitted to allow enough hose radius for free movement. It is also important to avoid sharp bends in hoses. As a general guideline hoses should not be bent round a radius smaller than ten times the hose diameter. This will vary with hose construction and any queries about specific hoses should be addressed either to your local dealer or the McConnel Service Department.

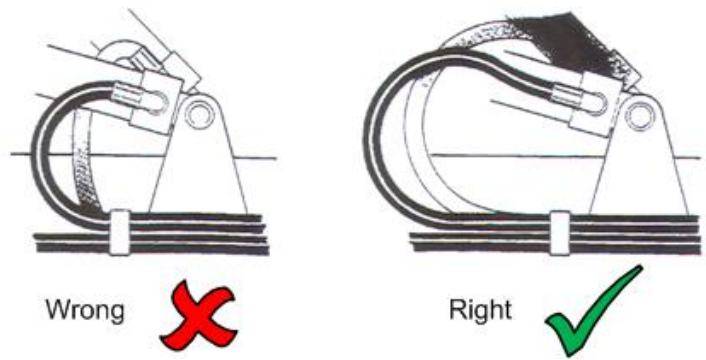

Chafing Hoses

It is important that hoses are fitted and clamped so that hose chafing is avoided. Always give plenty of clearance around sharp edges.



BSP SWIVEL FEMALE TORQUE VALUES				
Thread Diameter (inch)	Metric (Nm)		Imperial (lbf.ft)	
	nominal	Min - max	nominal	Min - max
1/4	20	15 - 25	14.75	11.06 - 18.44
3/8	34	27 - 41	25.07	19.91 - 30.24
1/2	60	42 - 76	44.25	30.97 - 56.05
5/8	69	44 - 94	50.88	32.45 - 69.32
3/4	115	95 - 135	84.81	70.06 - 99.56
1	140	115 - 165	103.24	84.81 - 121.68
1 1/4	210	140 - 280	154.87	103.24 - 206.49
1 1/2	290	215 - 365	213.86	158.55 - 269.17

METRIC SWIVEL FEMALE TORQUE VALUES				
Thread Diameter (mm x pitch)	Metric (Nm)		Imperial (lbf.ft)	
	nominal	Min - max	nominal	Min - max
M 16x1.5	26	25 - 28	19.18	18.44 - 20.65
M 18x1.5	37	35 - 39	27.29	25.81 - 28.76
M 22x1.5	47	45 - 50	34.67	33.19 - 36.88
M 26x1.5	89	85 - 94	65.64	62.69 - 69.33
M 30x2.0	116	110 - 121	85.56	81.13 - 89.25
M 36x2.0	137	130 - 143	101.05	95.88 - 105.47
M 45x2.0	226	215 - 237	166.69	158.58 - 174.80
M 16x1.5	42	40 - 44	30.98	29.50 - 32.45
M 18x1.5	53	50 - 55	39.09	36.88 - 40.57
M 20x1.5	63	60 - 66	46.47	44.25 - 48.68
M 22x1.5	79	75 - 83	58.27	55.32 - 61.22
M 24x1.5	84	80 - 88	61.99	59.00 - 64.91
M 30x2.0	126	120 - 132	92.93	88.51 - 97.36
M 36x2.0	179	170 - 187	132.02	125.39 - 137.92
M 42x2.0	263	250 - 275	193.98	184.39 - 202.83

GENERAL OPERATION

Operator Training

These notes are produced for guidance and are intended to help the operator obtain the best results from the machine, with the minimum of trouble and downtime. The operator should read the following pages carefully and be familiar with the contents before commencing work. A familiar knowledge of the operator instruction manual forms an essential part of the training record for a competent user.

These machines are primarily designed for the topping of grass pasture land after grazing, or for thistle and weed control on agricultural land and must not be used for any other purpose. The machines are not designed for grass mowing, set-aside cutting or brush/woodland clearance. Use in any other way than stipulated above is considered as contrary to the intended use. Compliance with, and strict adherence to, the conditions of operation, service, and repair, as specified in this manual is also considered as the intended use.

This machine should be operated, serviced, and repaired only by persons who are familiar with its particular characteristics and who are acquainted with the relevant safety procedures. Accident prevention regulations, all other generally recognised regulations on safety and occupational medicine, and all road traffic regulations must be observed at all times.

This operator's manual should be regarded as part of the machine. Suppliers of both new and second hand machines are advised to retain documentary evidence that this manual was provided with the machine. Make a note of the serial numbers inside the front cover of this manual. The serial number is stamped on the mainframe of the arm mower and on the cowl of the cutting unit. Always quote these numbers in any correspondence with a dealer.

Machine Inspection Records

A pro-forma for an inspection record sheet is on the following page; this can be used when inspecting the machine. This form can be photocopied from the manual. When completed and filed in a machine log these records together with the operator training records and service records can accumulate to a useful machine ownership record.

Machines should be checked pre-delivery, post installation and prior to each work shift. Inspection should be carried out preferably by the operator or a suitably qualified responsible person.

The tractor engine must be switched off with the key removed. The cutting head must be positioned flat on the ground or suitably rested on blocks either side of the cutting head. All hydraulics must be rested and residual pressure removed from any of the rams. Steam cleaning the machine will help with this inspection.

Maintenance Toolbox

The maintenance toolbox should contain a selection of replacement blades, blade bolts and blade bushes and washers matching those fitted to the blade bar prior to work. The toolbox should also contain the appropriate spanners to make the changes to blades and to remove guarding for inspection if necessary.

Machine Inspection Record Sheet

See table overleaf. This may be photocopied as many times as required for your records.

MACHINE INSPECTION RECORD		Pre-delivery inspection:	Select
		Installation inspection:	Select
		Daily pre-work inspection:	Select
Base model:	Base serial No:		
Inspector name (print):	Inspection date:		
Inspector signature:			
Visual Checks		Comments	OK
Check that an operator's instruction manual in the correct language for the working territory is in the machine document holder.			
Warning decals are present, clean and in good order			
Check any arms, wings or decks for any structural problems			
Look for any evidence of oil leaks from gearboxes, hoses and rams.			
View the blade bar or hangers for any damaged or excessively worn blades			
Review all the guards fitted to the machine and tractor, check with the parts book if unsure.			
Road lighting (if fitted) is clean and in working order			
Review the PTO shaft guard(s) to be in sound condition.			
Check hoses (if fitted) for damage, Kinks, twists, chafing or weeping.			
Check that the prime mover is equipped to supply the correct rpm at the Power Take-Off shaft			
Mechanical Checks		Comments	OK
All mounting fasteners to tractor need to be checked for tightness. This may require the machine being taken off the tractor to do this.			
Review the security and tightness of the main pivot pins and replace any missing securing bolts.			
Check blade pans for security to the rotor hub			
Check the security of any hose fittings for tightness			
Check the tightness of the blade fasteners by tightening – do not undo as locknuts may loosen.			
Check the tightness of the gearbox mounting fasteners			
Ensure gearbox oil is to the level plug.			
Check the PTO shaft bearing for any wear. Remove the shaft if necessary.			
Check tightness and condition of the side skids.			
Check and adjust tyre pressure. See tractor instruction book.			
Running Checks		Comments	OK
Once you are happy with the above start the tractor and run through the operational checks below.			
Ensure that any rams fitted respond as intended and in a smooth manner to the tractor controls.			
With the machine stationary on the ground run the blades up to operating speed and check for driveline vibration. If vibrating inspect the blades and driveline for cause.			
Check the function of any breakout system(s) fitted to the machine			
Slip clutch mechanisms if fitted to PTO shafts need regular checks for "freezing" and spring lengths, see maintenance section.			
Many PTO shafts from the tractors have shear bolt protection so the correct shear bolt grade needs to be fitted			
Check that the decks and wings are set up parallel to the ground. See the section on setting the cutting height.			
PTO shafts must be parallel to the tractors PTO shaft			

Operator Use and Adjustment

⚠ WARNING Before use ensure that all operators have read and thoroughly understood all the safety procedures. For further information refer to the relevant sections of this manual.

Machine Settings and Adjustments

⚠ WARNING Before working on any piece of attached machinery, ensure that the tractor engine is turned off and the starter key removed to prevent anyone else from starting the tractor while it is being worked on.

⚠ WARNING Always park on a suitable firm, level surface with the parking brake applied, and ensure the machine has come to a complete stop before commencing work.

⚠ WARNING Before attempting to access the underside of the machine, ensure it is adequately and safely supported. Do not rely on the tractor's hydraulics. Use safety supports that have a minimum 'Safe Working Load' (SWL) of 1.5 tonnes.

Cutting Height Adjustment

The cutting height of the pasture topper can be adjusted to cut at heights from 50mm to 175mm. This is achieved by moving the bolt-on skids at each side of the machine.

⚠ WARNING Use assistance when removing the skids - they are heavy and may cause injury.

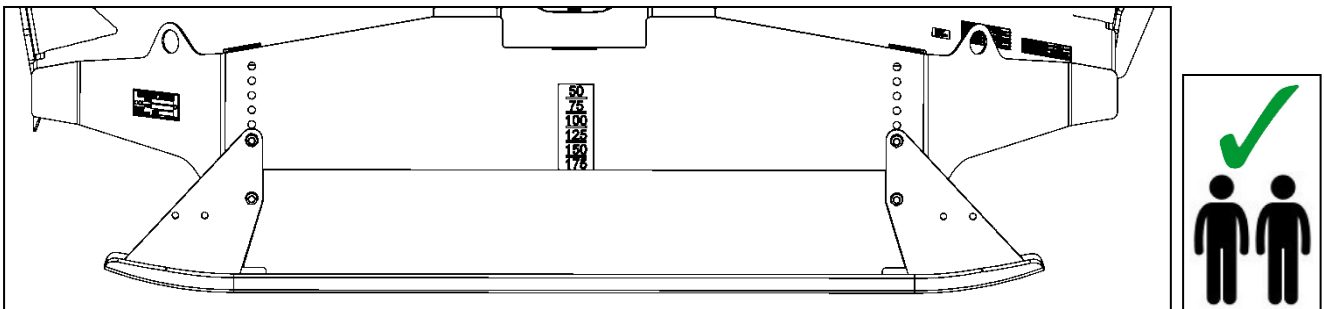

To Adjust the Cutting Height:

- Raise the machine on the tractor lift arms and support it on safety supports.
- Remove the nuts, bolts and washers securing the skid to the machine.
- Reposition the skid to the new desired position. Use the cutting height decals on the side of the machine.
- Fit and tighten all nuts and bolts securely, *refer to 'Torque Settings' page for torque figure.*
- Repeat the process for the other skid, ensuring that both skids are at the same height setting.
- Raise the machine on the lift arms and remove the safety supports.

Re-try the machine and re-adjust the skid height if the cutting height is still not acceptable.

Shear Bolt Protection

The P.T.O. shaft is fitted with a shear bolt overload protection to prevent damage to the machine if an obstacle is encountered during operation.

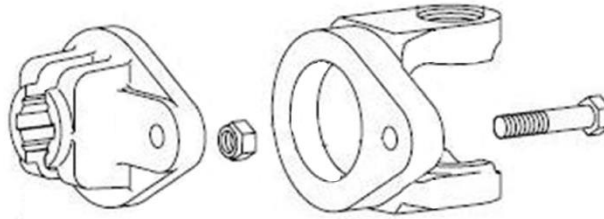

The shear bolt is located at the machine end of the PTO shaft. The procedure stated below should be followed when replacing or inspecting the shear bolt.

- Disengage the PTO.
- Raise the machine on the lift arms and move to an area with a firm, level surface.
- Lower the machine and stop the tractor.
- Apply the parking brake, and remove the starter key.
- Release the guard restraining chains and disconnect the PTO shaft from the tractor end first, and then from the machine. This will give access to the shear bolt for inspection and replacement.
- Inspect the machine, shaft and ground for possible causes of failure. Check that the blade rotates freely and do not foul on the body.
- Remove any bolt remains from the universal joint, and replace the shear bolt with the correct grade of new bolt. Four spare shear bolts and nuts are supplied with each new machine. These are stored on the 'A' frame or the headstock gearbox mounting plate. Ensure the bolt is correctly tightened – the shear bolt torque setting figure is 26Nm.

▲ CAUTION Only use the size and grade of shear bolt as supplied by the manufacturer of the machine. Refer to the machine's parts manual for details.

- Connect the shaft to the machine and then the tractor and attach the guard check chains.
- Re-start the machine as described in 'Running the Machine for the First Time' - check that it operates correctly.

Transportation to Work Site

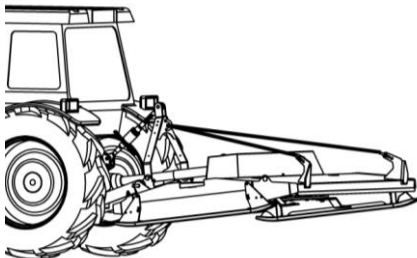

- With the PTO shaft correctly connected, raise the machine to a safe transport position. Lock the lift arm stop in this position.
- Check that there is no lateral movement on the machine when it is in the raised position. Adjust the tractor stabiliser chains (or bars) if required.

▲ CAUTION Raising the tractor lift arms too high may cause damage to the P.T.O. shaft if the tractor was to drive over any bumps and the machine was to bounce on the lift arms.

Before Driving on Public Roads the machine should be raised on the lift arms to the transport position and the following checks made;

- Is the machine correctly coupled with all securing pins and clips in position?
- Does the machine have any loose or unsecured parts?
- Does any part of the machine protrude beyond the width of the tractor?
- Are the tractor's lights, indicators and beacon working correctly and are they all clearly visible?
- Are there any bystanders or children in the immediate area? If so, ask them to clear the area before moving off.

Driving on Public Roads

⚠ DANGER Carrying passengers on the machine is strictly prohibited.

⚠ WARNING Read all the safety instructions carefully before driving on the public road. This will ensure that dangerous situations and accidents are avoided. Lack of information can cause accidents.

Comply with the local law concerning lights, warning and safety signs. The driver and/or the owner of the machine has the responsibility of complying with the local Road Traffic Acts.

The tractor's manoeuvrability should not be adversely affected. The steering axle of the tractor should be loaded with at least 20% of the tractor's dead weight.

Before driving off and whilst driving on public highways continue to monitor the following points;

- Check the area around the machine before you start.
- Be aware of children in the danger area of the machine.
- Do not exceed 30 km/h.
- Adjust the speed according to the road conditions.
- Avoid sudden sideways movement with the machine attached.
- Make sure that steering and braking ability are not compromised.
- Take care when turning corners, as the machine may swing out into the path of other road users.

Cutting Deployment and Retraction (In-line models only)

This section is only relevant to owners of in-line machines. To lower the machine from the transport position into the working position, first ensure that the machine and the PTO shaft have been correctly connected to the tractor - *refer to the machine preparation section*.

Visually confirm that the chosen location for deployment or retraction of the machine has plenty of clear space for the manoeuvre.

Lower the machine so that the skids are on the ground, apply tractor hand brake, and turn off tractor engine.

If possible set the lift arms to float to allow the skids to follow side to side undulations in the ground. If necessary adjust the top link to slacken the transport strap to allow for 50mm of play. This will allow the skids to follow fore / aft undulations in the ground.

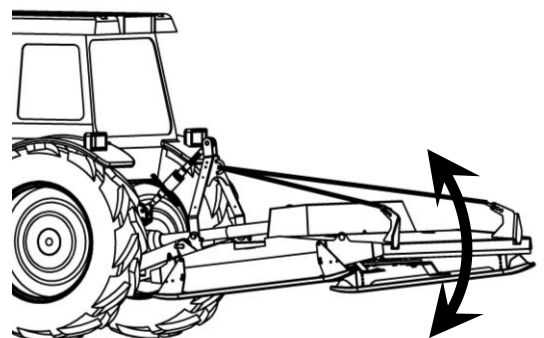

To move the machine from the working position to the transport position is the reverse of the above procedure. Before moving off in transport ensure lift arm float is disengaged and the lift arms are locked off.

⚠ DANGER

At no time should the machine be moved from working to transport position whilst the PTO is engaged, or the machine is running down. Ensure the rotors are at a complete standstill before moving.

⚠ WARNING

Serious damage to the driveline will result from deployment or retraction if the PTO is engaged, or the machine is running down.

Cutting Deployment and Retraction (Offset model only)

This section is only relevant to owners of offset machines. To move the machine from the transport position into the working position, first ensure that the machine and the PTO shaft have been correctly connected to the tractor - *refer to the machine preparation section.*

Visually confirm that the chosen location for deployment or retraction of the arm has plenty of clear space for the manoeuvre.

With the machine raised off the ground by at least 100mm, pull the transport latch release rope - at the same time, carefully operate the tractor hydraulic spool valve so that the hydraulic ram will pull the swing arm through 90 degrees. Ensure the ram is fully retracted.

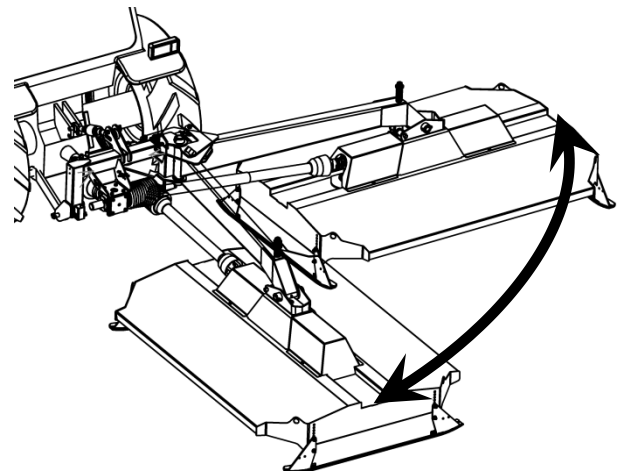

Lower the machine so that the skids are on the ground, apply tractor hand brake, and turn off tractor engine.

Dismount and remove the top link pin from the single hole on the headstock, and reposition top link with the pin in the slot directly below; this will improve head float when in use.

To operate the machine with the hydraulic safety break back feature, the hydraulic spool lever should be in “float” position; this gives free flow of oil return to the tractor should an obstacle be encountered.

⚠ WARNING

Failure to operate without break back free float return to the tractor may result in serious damage to your machine.

To move the machine from the working position to the transport position is the reverse of the above procedure. The spring on the transport latch will automatically lock the swing arm in position when the ram is fully extended.

⚠ DANGER

At no time should the machine be moved from working to transport position whilst the PTO is engaged, or the machine is running down. Ensure the rotors are at a complete standstill before moving swing arm.

⚠ WARNING

Serious damage to the driveline will result from arm deployment or retraction if the PTO is engaged, or the machine is running down.

Start-Up.

- Ensure that the machine and the PTO shaft have been correctly connected to the tractor.
- Ensure that the machine is positioned correctly in the working position.
- Visually confirm that there is plenty of space in the chosen location for run-up and checking of the machine.
- Ensure there are no children, bystanders or animals in the immediate area when the machine is run for the first time.

General Use – Grass Cutting.

Having transported the machine to the required work location, follow the guidelines below;

- Lower the machine fully so that both skids are firmly on the ground.
- Lift the machine so it clears the ground by approximately 100mm, gently engage the PTO and run at tick-over speed.
- Lower the machine to the ground, and increase the PTO speed to 540 rpm.
- Select a forward speed that is suitable for the ground conditions and the type of material to be cut.
- Check the machine is floating correctly..

NOTE: When turning at headlands, lift the machine so the skids just clear the ground; this will prevent damage to the hitch and reduce field damage in wet conditions.

If the stubble height is not correct, adjust the skid height accordingly.

Stopping the Machine

When stopping the machine, use the following procedure:

- Reduce forward speed and bring the tractor to a halt.
- Keep the machine lowered onto the ground.
- Reduce engine revs to idle speed, and disengage the PTO.
- When the rotor has stopped turning, raise the machine, and if applicable move the swing arm to the transport position.

REMOVAL, STORAGE AND DISPOSAL

Preparation for Storage

At the end of the season the machine should be readied for winter storage. Carry out the following:

- Clean the machine thoroughly.
- Always check that the machine's safety equipment is not worn or damaged.
- The PTO shaft should be cleaned, oiled and stored somewhere dry so as to avoid damage or corrosion.
- Repair any damaged components.
- Replace any defective components.
- Check and tighten all bolts.
- Lubricate the machine following the lubrication program.
- Repair any paint damage and replace any missing decals.
- Smear all unpainted metal parts with protective grease.
- Store the machine in a well ventilated building.

Cleaning the Machine

⚠ WARNING Always pay attention to the area and environment when carrying out any cleaning work; this will reduce the risk of injury to yourself and others.

Before cleaning:

- Check the area around the machine for hazardous or loose material.
- Apply the parking brake and stop the tractor.
- Remove the starter key from the tractor.
- Disconnect the PTO shaft.

Personal Protective Equipment (PPE)

Protect your body and face when cleaning the machine.

Wear the correct protective gear for body and face when cleaning the machine. This will protect your body and face from dirt and oil splashes. Insufficient protection of body and face can lead to severe skin and eye injuries.

Cleaning Agents

⚠ CAUTION Some cleaning products contain chemicals that are hazardous to the environment. Always take precautions to prevent spillage of fluids while cleaning.

⚠ CAUTION Only use pH neutral cleaning agents when cleaning the machine. pH neutral cleaning agents give your machine maximum protection. Cleaning agents with either high or low pH value can be corrosive on plastic, rubber and varnished surfaces.

⚠ CAUTION High pressure cleaning equipment may be used to clean. However, the area around the bearings should be cleaned using gentle squirts of water.

After Cleaning

Let the remaining water run off for about one hour.

Parking

⚠ DANGER The machine must be correctly secured when parked in storage. A correctly secured machine prevents serious accidents. If the machine is not properly secured when parked it can result in serious injuries or death.

The following guidelines should be adopted when parking-up the machine at the end of the season;

- The machine is placed on a firm and level surface.
- The tractor must not roll after being disconnected.
- The tractor has stopped, the parking brake is applied and the starter key is removed.
- The machine has come to a complete stop.
- Children are never allowed to play close to the machine.

Removal

Disconnection from the tractor is the reverse of attachment - see '*Machine Preparation*' section for details.

⚠ WARNING There is an increased risk of injury when disconnecting the machine from the tractor. Before disconnecting the machine, make sure that:

- The machine is placed upon a firm and level surface.
- The tractor cannot roll after being disconnected.
- The tractor has stopped, the parking brake is applied and the starter key is removed.
- The machine has come to a complete stop before commencing work.
- Children are never allowed to play close to the machine.

Disposal

When equipment reaches the end of its economic working life it should be disposed of responsibly, either through an approved recycling centre or by compliance with all applicable regulations in force in its final destination territory.

In most instances machines can be broken into its constituent parts with the use of basic workshop equipment. The chart on the following page contains a typical list of constituent materials, together with disposal guidelines.

When undertaking a machine breakdown take care to ensure heavy parts are adequately supported at all times to avoid injury and take containment precautions to retain control of liquids to avoid environmental contamination.

It is the owner's responsibility to ensure the machine is disposed of in accordance with all applicable regulations.

Material / Disposal Guide

MATERIAL	TYPICALLY FOUND IN	DISPOSAL GUIDELINE
Steel	Structural components, fixed guards, fasteners and driveline	Can be dismantled and recycled. Take care when handling heavy and/or sharp objects
Aluminium	Pump and gearbox housings, serial number plates	Can be dismantled and recycled. Take care when handling heavy and/or sharp objects. Take appropriate actions for oil contaminated products
Copper	Wiring, electrical components	Can be recycled using appropriate recovery procedures.
Hydraulic oil	Tank, hydraulic components	Dispose of in accordance with all applicable regulations
Rubber	Hoses, flexible guards, seals, 'O' rings	Dispose of in accordance with all applicable regulations
Plastics	Clips, caps, cable ties, decals, filter housings, document holders, bushes, electrical components, plugs, connectors, wire insulation	Dispose of in accordance with all applicable regulations
Filter element	Filter housings	Dispose of in accordance with all applicable regulations
Cork / paper	Gaskets	Dispose of in accordance with all applicable regulations
Oil	Gearboxes	All oil must be emptied from the machine. The oil that has been drained from the machine must be processed in accordance with current regulations

MAINTENANCE

Regular Maintenance Chart

Regular maintenance carried out at the intervals specified in the maintenance chart will ensure that the machine operates correctly and safely and minimise operational down time.

Component type and maintenance guideline	Maintenance intervals					
	1 st hour	After 10 hours	Weekly	Every 2 weeks	Monthly	Annually
PTO SHAFT						
Refer to the supplied PTO shaft manual for guidance on lubrication.						•
GEARBOXES						
Check primary gearbox mounting bolts.	•		•			•
Check primary gearbox oil level.		•		•		•
Change primary gearbox oil.						•
Check rotor gearbox mounting bolts.	•		•			•
Check rotor gearbox oil level.		•		•		•
Change rotor gearbox oil.						•
BLADE CARRIER						
Check mounting bolts.	•		•			•
BLADES						
Check for damage.		•	•			•
Check bushes for wear.		•			•	•
FLEXIBLE COUPLINGS						
Check coupling for cracks and damage.			•			•
OTHER						
Check all other fasteners.					•	•

Maintenance Safety

⚠ WARNING

Before attempting to access the underside of the machine, ensure it is adequately and safely supported. Do not rely on the tractor's hydraulics. Use safety supports that have a minimum 'Safe Working Load' (SWL) of 1.5 tonnes.

⚠ WARNING

Repair and maintenance work should only be performed if you have the necessary professional knowledge, the proper tools and comply with the following guidance:

- Always park on a suitable firm, level surface with the parking brake applied.
- Ensure the tractor engine is turned off and the starter key removed to prevent anyone else from starting the tractor while it is being worked on.
- Disconnect the PTO shaft.
- Never work between the tractor and the machine if the machine has not been secured.
- Always use genuine replacement parts on the machine.

Lubricating Oil Precautions

⚠️ WARNING Avoid excessive skin contact with used oil. Used oil contains potentially harmful contaminants which may cause skin cancer or other serious skin disorders.

- Avoid excessive skin contact with used lubricating oils and always adhere to the health protection precautions.
- Avoid prolonged and repeated contact with oils, particularly used engine oils.
- Wear protective clothing, including impervious gloves where practicable.
- Avoid contaminating clothes with oil (particularly those next to the skin). Overalls must be cleaned regularly. Discard heavily soiled clothing and oil impregnated footwear.
- First aid treatment should be obtained immediately for open cuts and wounds.
- Apply barrier creams before each work period, to help prevent lubricating oil from contaminating the skin.
- Use moisturisers after cleaning; preparations containing lanolin help replace the skin's natural oils which have been removed.
- If skin disorders develop, obtain medical advice without delay.
- If there is a risk of eye contamination wear eye protection (e.g. goggles or a face shield). Eye wash facilities should be provided in close vicinity of the work area.

NOTE: Used oil must be collected and be delivered to a disposal company, where the oil will be processed according to the governing regulations.

Power Take Off (PTO) Shaft

To increase the working life of the PTO shaft it should be periodically checked, cleaned and lubricated. Refer to the manufacturer's instructions, (supplied with the shaft), to adjust or service this component.

PT180 DRIVELINE

Gearbox Mountings Bolts

Check gearbox mounting nuts and bolts at the intervals stated in the regular maintenance chart and retighten if required. Locations of the mounting nuts and bolts are indicated in illustration below.

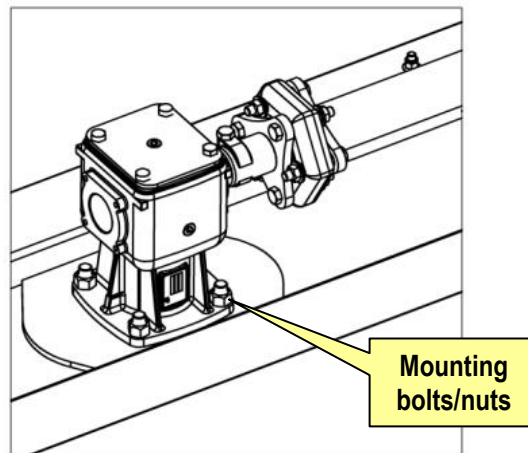

Oil Level

Check the gearbox oil level at the intervals stated in the regular maintenance chart. Ensure the machine is lowered to the ground and located on a firm level site to perform this task.

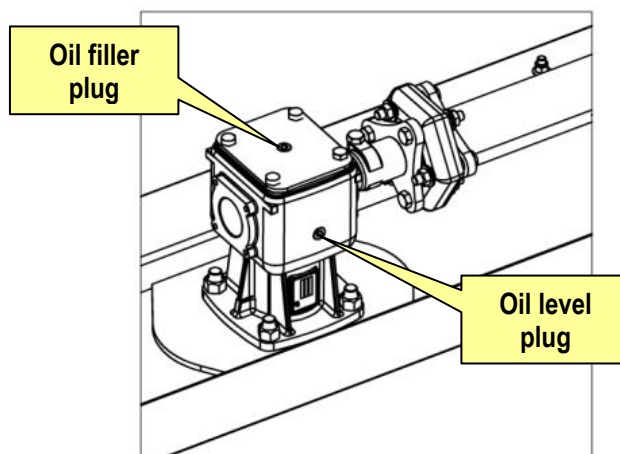

Checking the oil level in the gearbox is by removal of the oil level plug, indicated in the illustration above, the level is correct when the oil is up to the bottom of the side level plug orifice. If the gearbox requires 'topping up' add oil via the filler plug located on the top of the gearbox until it starts to seep from the side level plug orifice; replace both plugs securely to complete the task.

Gearbox oil levels must be checked on a fortnightly basis during the season and the oil completely drained and replaced annually.

Draining & Refilling

To drain oil from the gearbox it is necessary to remove the gearbox from the machine. Remove both the filler and the level plugs and invert the gearbox over a suitable container to allow the oil to drain completely. Replace the gearbox on the machine before refilling to the level stated above. Refer to recommended lubricants page for gearbox oil specifications.

PT240 & PT270 DRIVELINE

Twin rotor in-line machine are equipped with 3 gearboxes, a single central 'Tee' gearbox and two outer 90 degree gearboxes; these are all housed beneath the top cover of the machine. Access to the gearboxes is by unscrewing the fasteners and lifting clear.

Gearboxes Mounting Bolts

Check the mounting nuts and bolts of all 3 gearboxes at the intervals stated in the regular maintenance chart and retighten if required. Locations of the mounting nuts and bolts are indicated in the illustrations below.

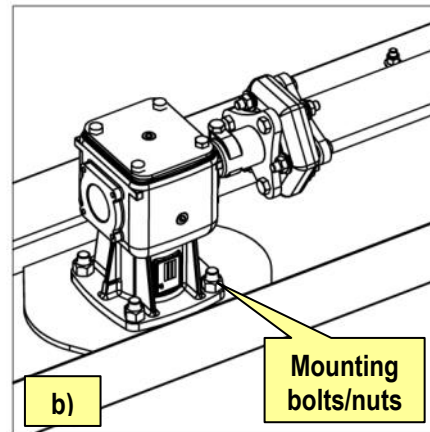
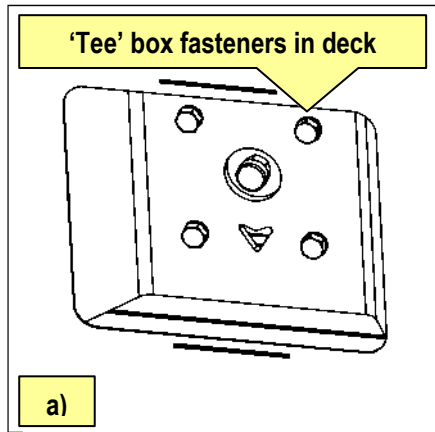

Gearbox Oil Level Check and Top-up

Check the gearbox oil levels at the intervals stated in the regular maintenance chart. Ensure the machine is lowered to the ground and located on a firm level site to perform this task.

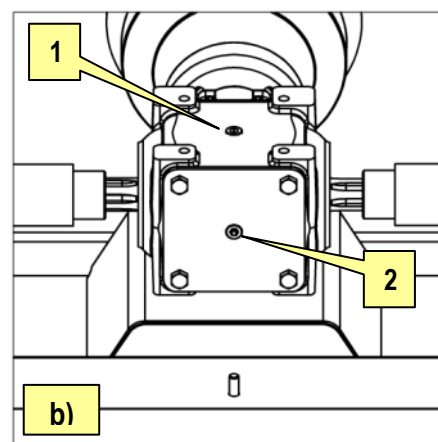
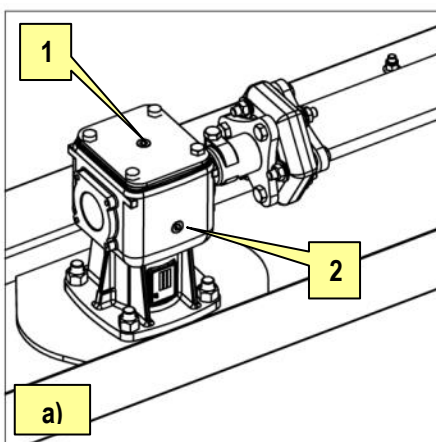

Checking the oil level in the gearboxes is by removal of the side Oil Level Plug, item (2) in illustrations above, the level is correct when the oil is up to the bottom of the level plug orifice. If the gearbox requires 'topping up' add oil via the filler plug, item (1) until it starts to seep from the level plug orifice; replace both plugs securely to complete the task. The left hand 90 degree drive box is shown in b), the right hand is similar as is the transfer 'Tee' box.

Gearbox oil levels must be checked on a fortnightly basis during the season and the oil completely drained and replaced annually.

Draining & Refilling

To drain oil from any of the gearboxes it is necessary to first remove the gearbox from the machine, the procedure is detailed below.

With the relevant gearbox off the machine, remove both the filler and the level plugs and invert the gearbox over a suitable container to allow the oil to drain completely. Replace the gearbox on the machine before refilling as detailed in the level check and topping up section. Refer to recommended lubricants page for gearbox oil specifications.

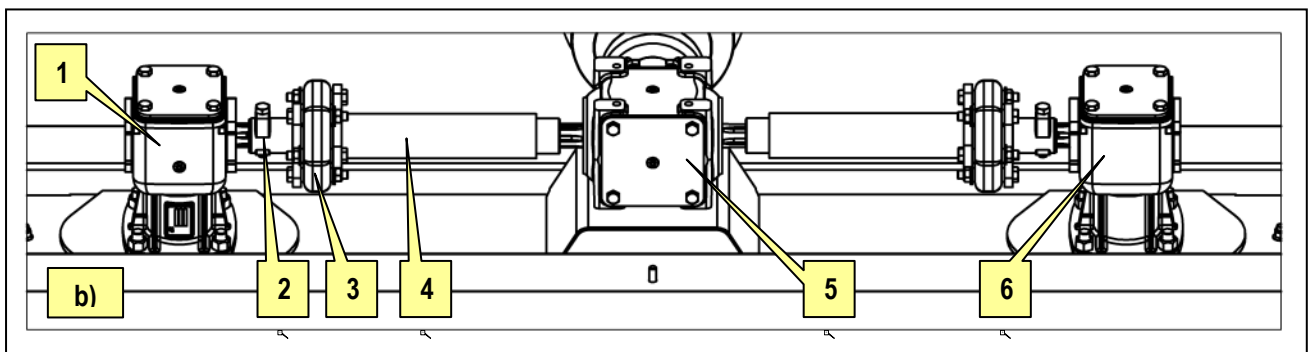
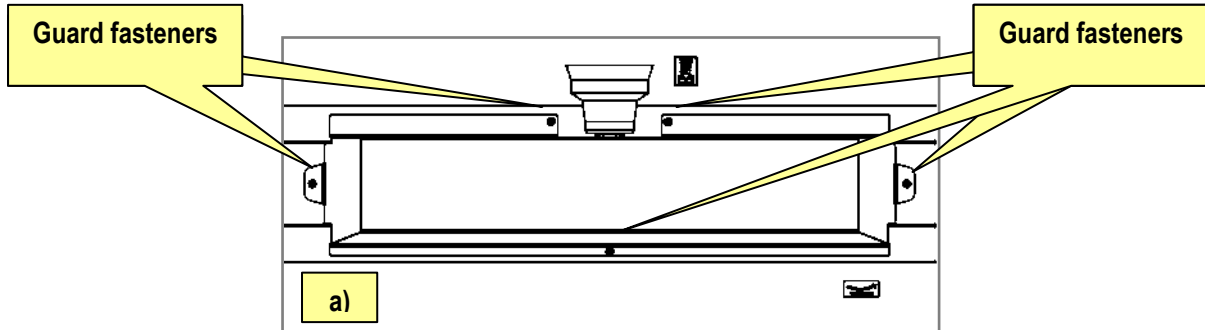

- | | | |
|----------------------|------------------------------------|-----------------------|
| 1) RH Outer Gearbox. | 2) Short Driveshaft Clamping Bolt. | 3) Flexible Coupling. |
| 4) Long Driveshaft. | 5) Centre Gearbox. | 6) LH Outer Gearbox. |

Gearboxes Removal Procedure

- Remove the drive guard by removing the guard fasteners.
- Remove the six flexible coupling mounting bolts.
- Remove the relevant short driveshaft clamping bolt.
- Slide the long driveshaft towards the central gearbox.
- Slide the short driveshaft towards the relevant outer gearbox.
- Remove the flexible coupling and both drive shafts and store them safely.
- Lift and support the machine on safety supports.
- With assistance, support the blade carrier, remove the split pin and rotor castle nut and remove the rotor from the splined gearbox output shaft - refer to 'Blade Carrier' removal instructions for details of this procedure.
- With assistance, remove the four nuts and mounting bolts securing the gearbox to the machine.
- Carefully remove the gearbox.

Gearboxes Replacement

Replacement of the gearboxes is a reversal of the removal procedure – ensure mounting bolts and castle nuts are tightened as specified in the 'Fastener Torque Guidelines'.

Flexible Couplings

Check each flexible coupling for damage and cracks. Replace if signs of damage are found.

Check the tightness of the short driveshaft clamping bolt and coupling mounting bolts to the correct torque. Repeat with the other drive coupling. Refer to 'Fastener Torque Guidelines'.

- 1) Short driveshaft clamp bolt (2 off)
- 2) Flexible coupling (2 off)
- 3) Flexible coupling mounting bolts (12 off)
- 4) Long driveshaft (2 off)

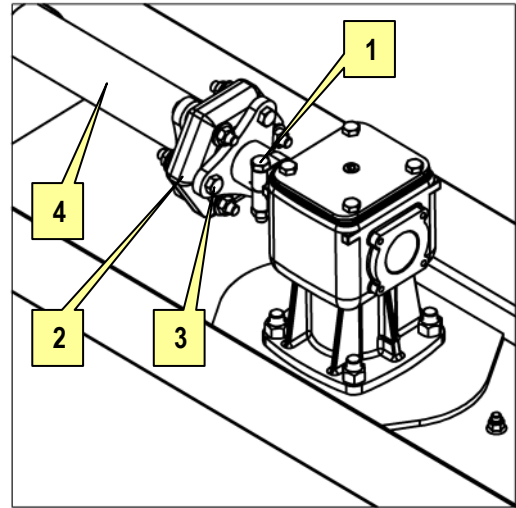

⚠ WARNING Ensure that the opposing blade carriers and blades are at 90° to each other after any maintenance that requires removing or replacing drive couplings.

PT240 OFFSET DRIVELINE

Gearboxes

The Rotor gearboxes are housed underneath the top covers. For access, unscrew the guard fixing bolt on top of the guard, and remove each guard.

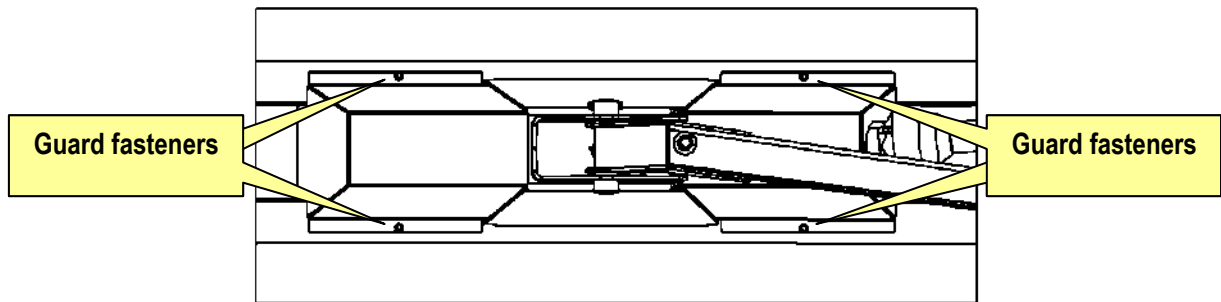

Gearboxes Mounting Bolts

Check the mounting nuts and bolts of all 3 gearboxes at the intervals stated in the regular maintenance chart and retighten if required. Locations of the mounting nuts and bolts are indicated in the illustration below.

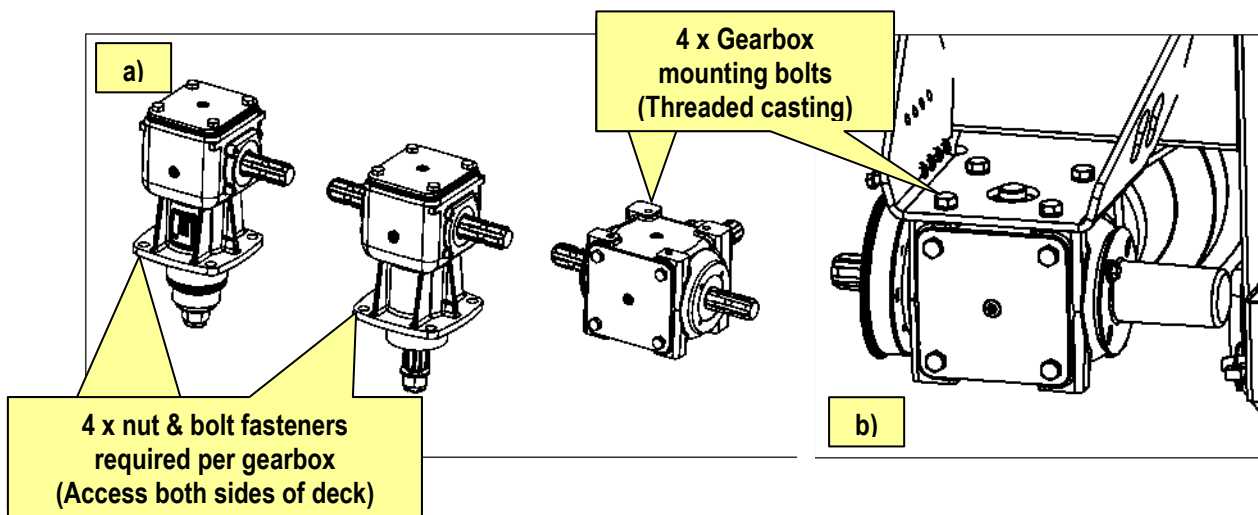

Gearbox Oil Level Check and Top-up

Before checking the oil level, ensure that the machine is positioned on a firm and level surface.

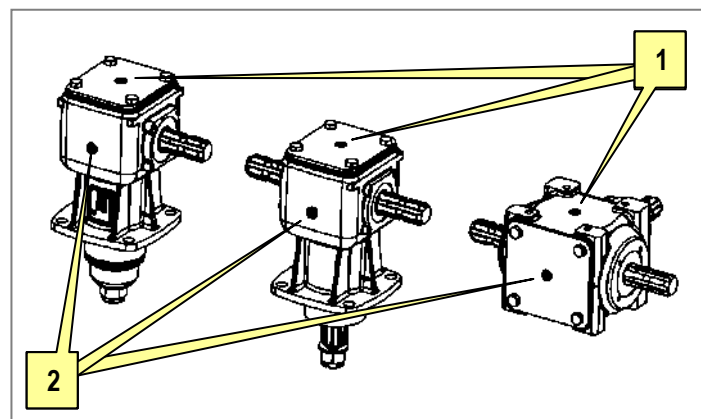

Remove the oil level plug, (*items 2 in the illustration above*), on the side of the gearbox, and ensure the oil is filled up to that level.

To top up the gearbox oil level, remove the oil filler plug, (*items 1 in the illustration above*), and carefully top up with oil until the oil starts to flow from the level plug (2). Use only the recommended grade of oil. *For further information refer to Lubricants section.*

Gearbox Oil Drain and Refill

To drain the oil from the gearbox, it is necessary to remove the gearbox from the machine. Remove both the oil filler and level plugs and invert the gearbox over a suitable container and allow the oil to drain.

Dispose of the used oil in accordance with the guidelines in removal, storage and disposal section.

Rotor Gearbox Removal Procedure

- Remove the six flexible coupling mounting bolts.
- Remove the relevant short driveshaft clamping bolt.
- Slide the long driveshaft towards the opposite rotor gearbox.
- Slide the short driveshaft towards the relevant rotor gearbox.
- Remove the flexible coupling and both drive shafts and store them safely.
- Lift and support the machine on safety supports.
- With assistance, support the blade carrier, remove the split pin and rotor castle nut and remove the rotor from the splined gearbox output shaft - refer to 'Blade Carrier' removal instructions for details of this procedure.
- With assistance, remove the four nuts and mounting bolts securing the gearbox to the machine.
- Remove the gearbox.

Gearboxes Replacement

Replacement is the reverse of removal. Tighten the mounting bolts and castle nut as specified in the 'Fastener Torque Guidelines'.



WARNING Ensure that the opposing blade carriers and blades are at 90° to each other after any maintenance that requires removing or replacing drive couplings.

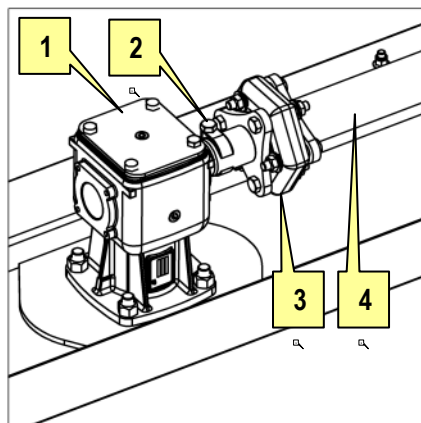

- 1) 90 Degree Rotor Gearbox.
- 2) Short Driveshaft Clamping Bolt.
- 3) Flexible Coupling.
- 4) Long Driveshaft.

Transfer Gearbox Removal Process

- Remove the PTO drive shaft from the tractor and store safely to one side – refer to photo a) below.
- Remove the PTO guard fastened to the transfer box, store safely to one side.
- Remove the drive shaft between the transfer box and the rotor 'Tee' gearbox by loosening the retaining circlip and store safely to one side – refer to photo b) below.
- Remove the PTO guard mounting collar and store safely to one side – refer to photo c) below.
- Whilst supporting the transfer box remove the 4 gearbox mounting bolts.

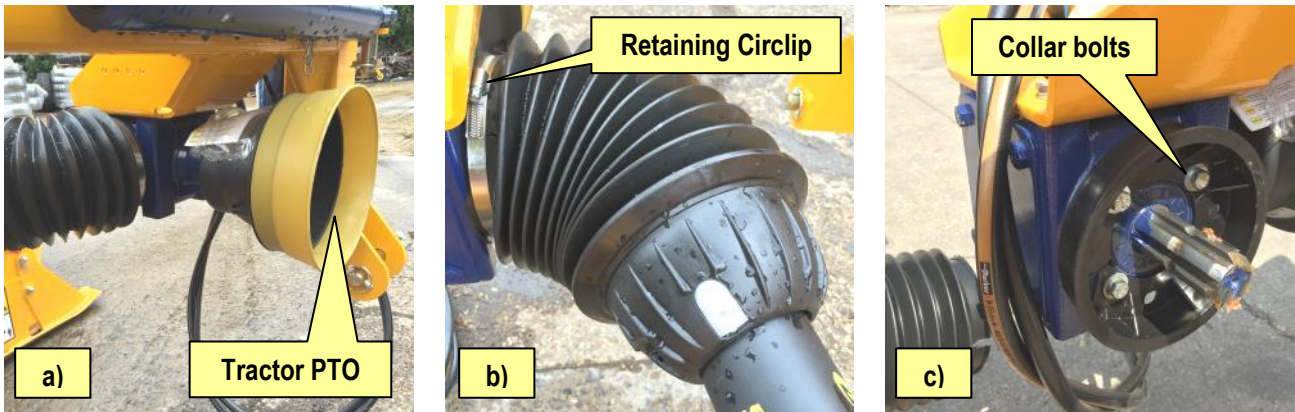

Blades

⚠ WARNING Ensure that the machine is safely supported using suitable lifting and support equipment before attempting to work beneath a machine – never use or rely on the tractor's hydraulic system to support the machine.

Blade Carrier Removal

Lift and support the machine on safety supports. With assistance, support the blade carrier, remove the split pin and rotor castle nut and remove the rotor from the splined gearbox output shaft, refer to illustration below.

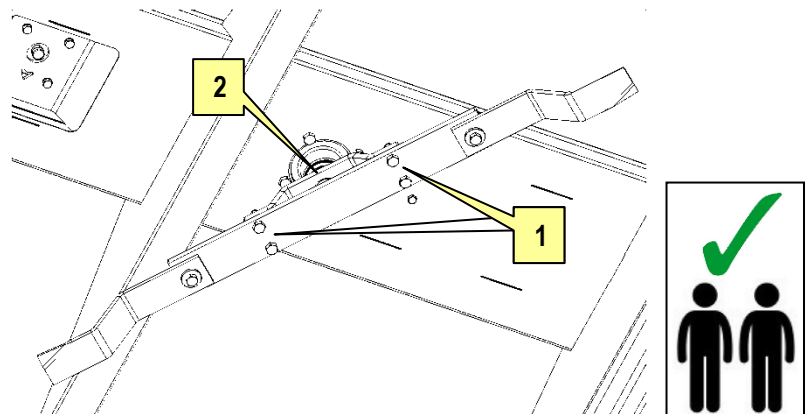

- 1) Blade Carrier Mounting Bolts & Nuts.
- 2) Rotor Hub Castle Nut.

Blade Carrier Replacement

Replacement is the reverse of removal procedure stated above - tighten the mounting bolts and castle nut as specified in the 'Fastener Torque Guidelines'.

Blade Carrier Maintenance

Check the rotor hub for slack. Some settlement may occur after the first hours of working. Re-tighten the castle nut one quarter of a turn at a time, and back off until the split pin can be fitted. Repeat until the slackness is removed. Check the blade carrier mounting bolts for tightness - refer to 'Fastener Torque Guidelines' for torque specification.

Blades and bushes

The cutting blades are mounted in bushes and are free-swinging to reduce shock load and damage to the transmission. Blades and blade bushes should be inspected for wear/damage the intervals stated in the regular maintenance chart.

Replace blades that are bent, excessively nicked, damaged, or when they are worn beyond the shape of their original profile. Always replace blades immediately when their level of wear or damage causes rotor vibration; continued use of the machine in this condition could cause damage to gearbox and/or drive components. Blades must always be replaced in opposing pairs to retain rotor balance. Replace bushes and blade fixings immediately should excessive signs of wear or damage be detected.

NOTE: On twin rotor machines the cutting blades on the left and right blade carriers are not interchangeable due to different rotation direction.

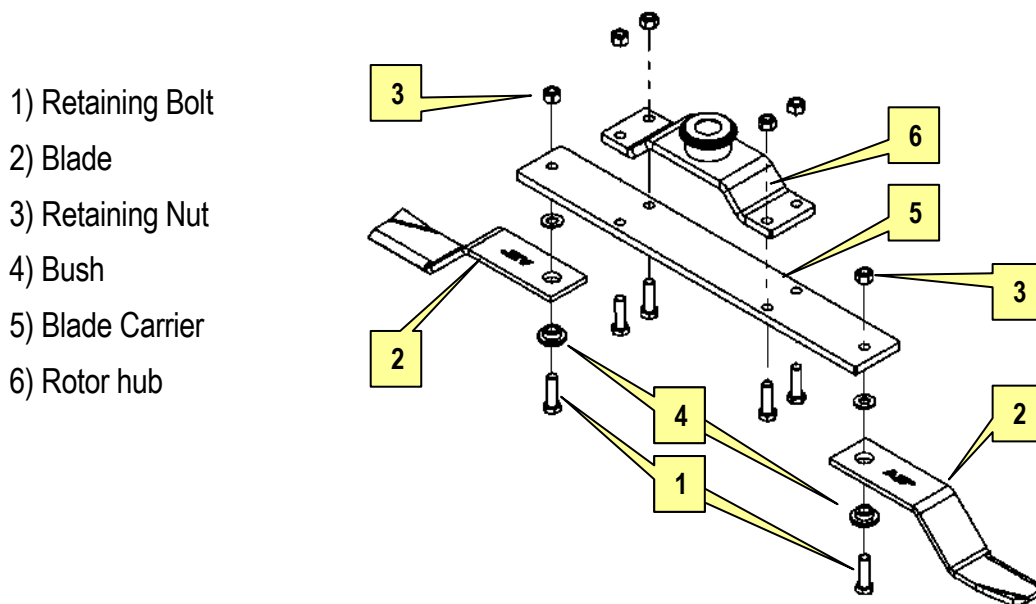

Blade & Blade Bush Removal

Remove the retaining bolt and nut and dismantle the blade and bush.

Blade and/or Blade Bush Replacement

Replace the blade and/or the bush and reassemble to the carrier with a new nut and bolt. Tighten the retaining bolt and nut. *Refer to 'General Torque Settings' for the specified torque.*

NOTE: On Twin Rotor machines the cutting blades on the left and right blade carriers are not interchangeable.

FASTENER TORQUE GUIDELINES

Specific Torque Settings

⚠ CAUTION This table refers to bolts that MUST be tightened to the figure shown. Where a specific torque setting is given it should be used instead of the information shown in this chart.

SPECIFIC TORQUE SETTINGS				
	PT180	PT240	PT240 Offset	PT270
Fastener	Setting (Nm)	Setting (Nm)	Setting (Nm)	Setting (Nm)
PTO Shaft Shear Bolt	26	26	26	26
Outer Gearbox Mounting Bolts	-	225	225	225
Centre Gearbox Mounting Bolts	225	90	90	90
Flexible Coupling Bolts	-	90	90	90
Blade Carrier Bolts	225	225	225	225
Cutting Blade Bolts	225	225	225	225
Rotor Hub Castle Nut	M24 x 2	<i>Refer to Blade Carrier</i>	<i>Refer to Blade Carrier</i>	<i>Refer to Blade Carrier</i>

General Torque Settings

⚠ CAUTION This table refers to bolts without a torque setting specified above. In the first instance please refer to the chart above. Where a specific torque setting is given it should be used instead of the information below.

The figures shown are for the torque moment for bolts of normal metric thread quality 8.8 black and/or galvanised and ungreased when tightened on a smooth surface or a plain washer.

Thread Diameter (mm)	Nm + 10% / - 0
5	6
6	10
8	26
10	52
12	90
14	144
16	225
20	436
22	594

TROUBLE SHOOTING CHART

SYMPTOM	POSSIBLE CAUSE	REMEDY
Machine vibration.	Missing Blades	Replace opposite blades as pairs
	Broken Blades	Replace opposite blades as pairs
	Wrong PTO speed	Check that 540 rpm machine is not run at 1000rpm
Blades touching one another.	Blades are out of timing	Re index the blades but check that there are no teeth failures within the gearbox
PTO shaft not transmitting power.	Slip clutch if fitted slipping	Re set the clutches as per the instruction book
	Shear bolt failed if fitted	Replace the shear bolt after checking that the correct grade is being used
		Check that the shear surfaces are still square and not rounded.
	Check that shear bolts are tight.	
Uneven cutting height.	Machine not set level with ground	Stop the machine and set the machine as shown in the instruction book
Machine not cutting.	Blades not fitted to suit rotation	Check the blade rotation suites the cutting edge of the blade
Leaking gearbox.	Oil level too high	Reduce the oil level to the level plug
	Wrong oil grade	Check instruction book for the correct grade
	Faulty breather	Replace the breather
	Wrong breather alignment with crown wheel	Rotate the cover with the breather so the breather is off set to the crown wheel
Rapid blade wear.	Cutting too low	Set the machine for sensible cutting height
Blades hitting the machine sides.	Worn pivot collars and bolts	Replace any worn collars and or bolts. Remember to replace lock nuts at the same time.
Breakout system if fitted not working.	Machine will not break out	If hydraulic check that the tractor valve is in "float" whilst cutting.
Machine will not "float".	Poor setting of any balance spring(s)	Reset any balance spring as per the instruction book
Wings, if fitted, will not drop or do so reluctantly.	Twisted wing PTO shafts	Reset "frozen" wing PTO shafts and replace the PTO shaft drive tube
Loss of drive to one axle.	Drive shaft or gearbox tooth failure	Replace damage parts and check slip clutches and or shear bolt grade/size



McConnel Limited, Temeside Works, Ludlow, Shropshire SY8 1JL. England.
Telephone: 01584 873131. Facsimile: 01584 876463. www.mcconnel.com