

Publication 517
April 2007
Part No. 41571.17
Revision: 11.10.07

FW6000

ROTARY FLEX WING MOWER



Operation Manual



IMPORTANT

VERIFICATION OF WARRANTY REGISTRATION



DEALER WARRANTY INFORMATION & REGISTRATION VERIFICATION

It is imperative that the selling dealer registers this machine with McConnel Limited before delivery to the end user – failure to do so may affect the validity of the machine warranty.

To register machines go to the McConnel Limited web site at www.mccommel.com, log onto 'Dealer Inside' and select the 'Machine Registration button' which can be found in the Service Section of the site. Confirm to the customer that the machine has been registered in the section below.

Should you experience any problems registering a machine in this manner please contact the McConnel Service Department on 01584 875848.

Registration Verification

Dealer Name:
Dealer Address:
Customer Name:
Date of Warranty Registration:/...../..... Dealer Signature:

NOTE TO CUSTOMER / OWNER

Please ensure that the above section above has been completed and signed by the selling dealer to verify that your machine has been registered with McConnel Limited.

IMPORTANT: During the initial 'bedding in' period of a new machine it is the customer's responsibility to regularly inspect all nuts, bolts and hose connections for tightness and re-tighten if required. New hydraulic connections occasionally weep small amounts of oil as the seals and joints settle in – where this occurs it can be cured by re-tightening the connection – *refer to torque settings chart below*. The tasks stated above should be performed on an hourly basis during the first day of work and at least daily thereafter as part of the machines general maintenance procedure.

CAUTION: DO NOT OVER TORQUE HYDRAULIC FITTINGS AND HOSES

TORQUE SETTINGS FOR HYDRAULIC FITTINGS

HYDRAULIC HOSE ENDS		
BSP	Setting	Metric
1/4"	18 Nm	19 mm
3/8"	31 Nm	22 mm
1/2"	49 Nm	27 mm
5/8"	60 Nm	30 mm
3/4"	80 Nm	32 mm
1"	125 Nm	41 mm
1.1/4"	190 Nm	50 mm
1.1/2"	250 Nm	55 mm
2"	420 Nm	70 mm

PORT ADAPTORS WITH BONDED SEALS		
BSP	Setting	Metric
1/4"	34 Nm	19 mm
3/8"	47 Nm	22 mm
1/2"	102 Nm	27 mm
5/8"	122 Nm	30 mm
3/4"	149 Nm	32 mm
1"	203 Nm	41 mm
1.1/4"	305 Nm	50 mm
1.1/2"	305 Nm	55 mm
2"	400 Nm	70 mm

WARRANTY POLICY

WARRANTY REGISTRATION

All machines must be registered, by the selling dealer with McConnel Ltd, before delivery to the end user. On receipt of the goods it is the buyer's responsibility to check that the Verification of Warranty Registration in the Operator's Manual has been completed by the selling dealer.

1. LIMITED WARRANTIES

- 1.01. *All mounted machines supplied by McConnel Ltd are warranted to be free from defects in material and workmanship from the date of sale to the original purchaser for a period of 12 months, unless a different period is specified.
All Self Propelled Machines supplied by McConnel Ltd are warranted to be free from defects in material and workmanship from the date of sale to the original purchaser for a period of 12 months or 1500 hours. Engine warranty will be specific to the Manufacturer of that unit.*
- 1.02. *All spare parts supplied by McConnel Ltd and purchased by the end user are warranted to be free from defects in material and workmanship from the date of sale to the original purchaser for a period of 6 months. All parts warranty claims must be supported by a copy of the failed part invoice to the end user. We cannot consider claims for which sales invoices are not available.*
- 1.03. *The warranty offered by McConnel Ltd is limited to the making good by repair or replacement for the purchaser any part or parts found, upon examination at its factory, to be defective under normal use and service due to defects in material or workmanship. Returned parts must be complete and unexamined. Pack the component(s) carefully so that any transit damage is avoided. All ports on hydraulic items should be drained of oil and securely plugged to prevent seepage and foreign body ingress. Certain other components, electrical items for example, may require particular care when packing to avoid damage in transit.*
- 1.04. *This warranty does not extend to any product from which McConnel Ltd's serial number plate has been removed or altered.*
- 1.05. *The warranty policy is valid for machines registered in line with the terms and conditions detailed and on the basis that the machines do not extend a period of 24 months or greater since their original purchase date, that is the original invoice date from McConnel Limited.
Machines that are held in stock for more than 24 months cannot be registered for warranty.*
- 1.06. *This warranty does not apply to any part of the goods, which has been subjected to improper or abnormal use, negligence, alteration, modification, fitment of non-genuine parts, accident damage, or damage resulting from contact with overhead power lines, damage caused by foreign objects (e.g. stones, iron, material other than vegetation), failure due to lack of maintenance, use of incorrect oil or lubricants, contamination of the oil, or which has served its normal life. This warranty does not apply to any expendable items such as blades, belts, clutch linings, filter elements, flails, flap kits, skids, soil engaging parts, shields, guards, wear pads, pneumatic tyres or tracks.*
- 1.07. *Temporary repairs and consequential loss - i.e. oil, downtime and associated parts are specifically excluded from the warranty.*
- 1.08. *Warranty on hoses is limited to 12 months and does not include hoses which have suffered external damage. Only complete hoses may be returned under warranty, any which have been cut or repaired will be rejected.*
- 1.09. *Machines must be repaired immediately a problem arises. Continued use of the machine after a problem has occurred can result in further component failures, for which McConnel Ltd cannot be held liable, and may have safety implications.*
- 1.10. *If in exceptional circumstances a non McConnel Ltd part is used to effect a repair, warranty reimbursement will be at no more than McConnel Ltd's standard dealer cost for the genuine part.*

- 1.11. *Except as provided herein, no employee, agent, dealer or other person is authorised to give any warranties of any nature on behalf of McConnell Ltd.*
- 1.12. *For machine warranty periods in excess of 12 months the following additional exclusions shall apply:*
 - 1.12.1. *Hoses, exposed pipes and hydraulic tank breathers.*
 - 1.12.2. *Filters.*
 - 1.12.3. *Rubber mountings.*
 - 1.12.4. *External electric wiring.*
 - 1.12.5. *Bearings and seals*
 - 1.12.6. *External Cables, Linkages*
 - 1.12.7. *Loose/Corroded Connections, Light Units, LED's*
 - 1.12.8. *Comfort items such as Operator Seat, Ventilation, Audio Equipment*
- 1.13. *All service work, particularly filter changes, must be carried out in accordance with the manufacturer's service schedule. Failure to comply will invalidate the warranty. In the event of a claim, proof of the service work being carried out may be required.*
- 1.14. *Repeat or additional repairs resulting from incorrect diagnosis or poor quality previous repair work are excluded from warranty.*

NB Warranty cover will be invalid if any non-genuine parts have been fitted or used. Use of non-genuine parts may seriously affect the machine's performance and safety. McConnell Ltd cannot be held responsible for any failures or safety implications that arise due to the use of non-genuine parts.

2. REMEDIES AND PROCEDURES

- 2.01. *The warranty is not effective unless the Selling Dealer registers the machine, via the McConnell web site and confirms the registration to the purchaser by completing the confirmation form in the operator's manual.*
- 2.02. *Any fault must be reported to an authorised McConnell Ltd dealer as soon as it occurs. Continued use of a machine, after a fault has occurred, can result in further component failure for which McConnell Ltd cannot be held liable.*
- 2.03. *Repairs should be undertaken within two days of the failure. Claims submitted for repairs undertaken more than 2 weeks after a failure has occurred, or 2 days after the parts were supplied will be rejected, unless the delay has been authorised by McConnell Ltd. Please note that failure by the customer to release the machine for repair will not be accepted as a reason for delay in repair or submitting warranty claims.*
- 2.04. *All claims must be submitted, by an authorised McConnell Ltd Service Dealer, within 30 days of the date of repair.*
- 2.05. *Following examination of the claim and parts, McConnell Ltd will pay, at their discretion, for any valid claim the invoiced cost of any parts supplied by McConnell Ltd and appropriate labour and mileage allowances if applicable.*
- 2.06. *The submission of a claim is not a guarantee of payment.*
- 2.07. *Any decision reached by McConnell Ltd. is final.*

3. LIMITATION OF LIABILITY

- 3.01. *McConnell Ltd disclaims any express (except as set forth herein) and implied warranties with respect to the goods including, but not limited to, merchantability and fitness for a particular purpose.*
- 3.02. *McConnell Ltd makes no warranty as to the design, capability, capacity or suitability for use of the goods.*
- 3.03. *Except as provided herein, McConnell Ltd shall have no liability or responsibility to the purchaser or any other person or entity with respect to any liability, loss, or damage caused or alleged to be caused directly or indirectly by the goods including, but not limited to, any indirect, special, consequential, or incidental damages resulting from the use or operation of the goods or any breach of this warranty. Notwithstanding the above limitations and warranties, the manufacturer's liability hereunder for damages incurred by the purchaser or others shall not exceed the price of the goods.*
- 3.04. *No action arising out of any claimed breach of this warranty or transactions under this warranty may be brought more than one (1) year after the cause of the action has occurred.*

4. MISCELLANEOUS

- 4.01. McConnel Ltd may waive compliance with any of the terms of this limited warranty, but no waiver of any terms shall be deemed to be a waiver of any other term.*
- 4.02. If any provision of this limited warranty shall violate any applicable law and is held to be unenforceable, then the invalidity of such provision shall not invalidate any other provisions herein.*
- 4.03. Applicable law may provide rights and benefits to the purchaser in addition to those provided herein.*

McConnel Limited



DECLARATION OF CONFORMITY

Conforming to EU Machinery Directive 2006/42/EC

We,

McCONNEL LIMITED, Temeside Works, Ludlow, Shropshire SY8 1JL, UK

Hereby declare that:

The Product; *Rotary Trailed Flex Wing Mower*

Product Code; *FW60*

Serial No. & Date Type

Manufactured in; *United Kingdom*

Complies with the required provisions of the Machinery Directive 2006/42/EC
The machinery directive is supported by the following harmonized standards;

- BS EN ISO 12100 (2010) Safety of machinery – General principles for design – Risk assessment and risk reduction.
- BS EN 349 (1993) + A1 (2008) Safety of machinery - Minimum distances to avoid the entrapment with human body parts.
- BS EN ISO 14120 (2015) Safety of machinery - Guards general requirements for the design and construction of fixed and movable guards.
- BS EN 4413 (2010) Hydraulic fluid power. Safety requirements for systems and their components.

McCONNEL LIMITED operates an ISO 9001:2008 quality management system, certificate number: FM25970.

This system is continually assessed by the;

British Standards Institution (BSI), Beech House, Milton Keynes, MK14 6ES, UK

BSI is accredited by UK Accreditation Service, accreditation number: UKAS 003.

The EC declaration only applies if the machine stated above is used in accordance with the operating instructions.

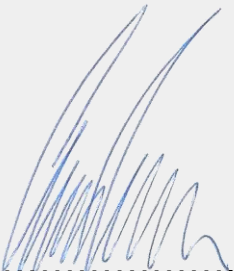
Signed  *Responsible Person*
CHRISTIAN DAVIES on behalf of McCONNEL LIMITED

Status: *General Manager*

Date: *January 2018*

ROTARY MOWER INSPECTION AND MAINTENANCE

A daily equipment inspection of the tractor and mower should be conducted before the equipment is used. You may use the inspection sheets to assist with these daily inspections. Any damaged or missing guards should be repaired or replaced before operating the mower. Failure to repair the damaged shield can result in objects being thrown from the mower and possibly hitting the operator or bystander.

Inspect the Mower for Safe Operating Condition

- Make sure the driveline guards and shielding are in place and in good repair.
- Inspect the chain guards, flexible and/or solid deflector thrown object shielding to assure that they are in place on the front and rear of the mower deck and in good repair. Repair or replace any damaged or missing thrown object shields.
- Remove all debris and cut material from the deck and around the gearboxes.
- Ensure the mower cutting height is set high enough to reduce the possibility of the mower blades contacting the ground. Actual height will be dependent on the ground conditions. Increase the height when working in rough or undulating conditions.
- Inspect for broken, chipped, bent, missing, or severely worn blades. Replace damaged blades before operating the mower. Ensure the blade retaining bolts and fasteners are secure and tight.
- Lubricate the driveline universal joints and telescoping members daily.
- Inspect the wheel lug bolt/nuts to assure that they are tight.
- If mower is equipped with pneumatic tires, make sure they have the required air pressure.
- Inspect for worn or damaged decals and safety instructions. Replace unreadable, damaged or missing safety decals.
- Follow the operator's manual(s) inspection and maintenance instructions for lubricating parts, and keeping thrown object shielding, driveline guards, rotating parts shields, mower blades and decals in good repair.

Inspect the Tractor for Safe Operating Condition:

- Inspect the controls, lights, SMVs (Slow Moving Vehicle sign), seat belts, and ROPS to assure that they are in place and in good working order.
- Be sure the tires, wheels, lug bolts/nuts are in good condition.
- Make sure the tractor brakes and steering are in proper operating condition.
- Follow the operator's manual(s) inspection and maintenance procedures for keeping the tractor in good and safe condition before operating.

The inspection sheet on the following page should be kept in this book as a record. A second sheet is included for you to cut out and photocopy or the inspection sheets can be downloaded from our web site at;

<http://www.mcconnel.com/support/aftersales/default.aspx?nav=After Sales>



FLEX WING MOWER PRE-OPERATION Inspection

Mower ID _____ Date: _____ Shift: _____

WARNING



Before conducting the inspection, make sure the tractor engine is off, the key removed, all rotation has stopped and the tractor is in park with the parking brake engaged. Make sure the mower wings are resting on the ground or securely blocked up, or are retained in the transport by pins and all hydraulic pressure has been relieved.

Item	Condition at start of shift	Specific Comments if not O.K.
The Operator's Manual is in the Canister on the mower		
All Warning Decals are in place and legible		
All Lights are clean and working		
Tongue/Hitch connection bolts & pins are tight		
There are no cracks in Tongue or Hitch		
Hyd. Cylinder pins are properly retained		
There are no oil leaks		
There are no damaged hoses		
Gearboxes & mower decks are clear of cut grass and debris		
Chain Guards/Deflectors are in place & in good condition		
Driveline/Gearbox shields/guards are in good condition		
Driveline clutches are in good condition, not frozen		
Driveline telescoping members & u-joints are lubricated		
Driveline yokes are securely attached to tractor & mower		
Gearbox mounting bolts are tight		
Blade carrier retaining nut is tight		
Blades are not chipped, cracked, bent or worn out		
Blade bolts are tight		
Side skirts and skids are in good condition		
There are no holes or cracks in the machine deck		
Wheel nuts are tight		
Tyre pressures are correct		
Transport locks are in good condition		
All axle mounting pins are correctly secured		

Operators Signature: _____

DO NOT OPERATE an UNSAFE TRACTOR or MOWER



TRACTOR PRE-OPERATION Inspection

Power Arm ID _____ Date: _____ Shift: _____

WARNING



Before conducting the inspection, make sure the tractor engine is off, the key is removed all rotation has stopped and the tractor is in park with the parking brake engaged. Any implement attached to the tractor is firmly on the ground.

Item	Condition at start of shift	Specific Comments if not O.K.
The flashing lights function properly.		
All lights are clean and working correctly		
All cab windows are clean and wipers working correctly		
The SMV sign, where required, is clean and visible.		
The tyres are in good condition with correct pressure.		
The wheel nuts are tight.		
The tractor brakes are in good condition.		
The steering linkage is in good condition.		
There are no visible oil leaks.		
The hydraulic controls function properly.		
The ROPS or ROPS cab is in good condition.		
The seatbelt is in place and in good condition.		
The 3-point hitch is in good condition.		
The drawbar/pick up hook is secure & in good condition		
The PTO master shield is in place.		
The engine oil level is full.		
The brake fluid level is full.		
The power steering fluid level is full.		
The fuel level is adequate.		
The engine coolant fluid level is full.		
The radiator & oil cooler are free of debris.		
The air filter is in good condition		

Operators Signature: _____

DO NOT OPERATE an UNSAFE TRACTOR or MOWER



FLEX WING MOWER PRE-OPERATION Inspection

Mower ID _____ Date: _____ Shift: _____

WARNING



Before conducting the inspection, make sure the tractor engine is off, the key removed, all rotation has stopped and the tractor is in park with the parking brake engaged. Make sure the mower wings are resting on the ground or securely blocked up, or are retained in the transport by pins and all hydraulic pressure has been relieved.

Item	Condition at start of shift	Specific Comments if not O.K.
The Operator's Manual is in the Canister on the mower		
All Warning Decals are in place and legible		
All Lights are clean and working		
Tongue/Hitch connection bolts & pins are tight		
There are no cracks in Tongue or Hitch		
Hyd. Cylinder pins are properly retained		
There are no oil leaks		
There are no damaged hoses		
Gearboxes & mower decks are clear of cut grass and debris		
Chain Guards/Deflectors are in place & in good condition		
Driveline/Gearbox shields/guards are in good condition		
Driveline clutches are in good condition, not frozen		
Driveline telescoping members & u-joints are lubricated		
Driveline yokes are securely attached to tractor & mower		
Gearbox mounting bolts are tight		
Blade carrier retaining nut is tight		
Blades are not chipped, cracked, bent or worn out		
Blade bolts are tight		
Side skirts and skids are in good condition		
There are no holes or cracks in the machine deck		
Wheel nuts are tight		
Tyre pressures are correct		
Transport locks are in good condition		
All axle mounting pins are correctly secured		

Operators Signature: _____

DO NOT OPERATE an UNSAFE TRACTOR or MOWER



TRACTOR PRE-OPERATION Inspection

Power Arm ID _____ Date: _____ Shift: _____

WARNING



Before conducting the inspection, make sure the tractor engine is off, the key is removed all rotation has stopped and the tractor is in park with the parking brake engaged. Any implement attached to the tractor is firmly on the ground.

Item	Condition at start of shift	Specific Comments if not O.K.
The flashing lights function properly.		
All lights are clean and working correctly		
All cab windows are clean and wipers working correctly		
The SMV sign, where required, is clean and visible.		
The tyres are in good condition with correct pressure.		
The wheel nuts are tight.		
The tractor brakes are in good condition.		
The steering linkage is in good condition.		
There are no visible oil leaks.		
The hydraulic controls function properly.		
The ROPS or ROPS cab is in good condition.		
The seatbelt is in place and in good condition.		
The 3-point hitch is in good condition.		
The drawbar/pick up hook is secure & in good condition		
The PTO master shield is in place.		
The engine oil level is full.		
The brake fluid level is full.		
The power steering fluid level is full.		
The fuel level is adequate.		
The engine coolant fluid level is full.		
The radiator & oil cooler are free of debris.		
The air filter is in good condition		

Operators Signature: _____

DO NOT OPERATE an UNSAFE TRACTOR or MOWER

LIST OF CONTENTS

Section	Page No.
INTRODUCTION	1
SPECIFICATIONS & TECHNICAL DATA	2
GENERAL ARRANGEMENT	3
MACHINE DIMENSIONS	5
SAFETY	7
SAFETY DECALS	10
INSTALLATION	11
OPERATION	19
TRANSPORTATION	23
MAINTENANCE	25

INTRODUCTION

The FW6000 Rotary Flex Wing Mower is a drawbar mounted trailed mower with a 6.0 metre cutting width, suitable for use with tractors of 80HP and above. The cutting height of the machine is hydraulically adjustable and features a 'self-levelling' system to ensure the deck remains parallel irrespective of the cutting height.

The hydraulically operated wings, powered from the tractors spool valve, can be operated at angles of up to 22° downwards and 18.5° upwards for optimum cutting performance on contoured ground. With both wings raised and locked in the upright position the machine becomes a compact unit for safe transportation to and from the work site.

Power from the tractor to the machine is transferred to the cutting units via driveshafts and gearboxes - Driveshafts are fitted with slip clutch protection to absorb shock loads and protect driveline components. Replaceable skid shoes and rear lighting equipment (for highway transport) are provided as standard.

This machine is designed primarily for set-aside and large pasture topping – In the interest of safety and for the protection of your mower you must never use this machine to perform tasks it was not designed to do.

SPECIFICATIONS & TECHNICAL DATA

SPECIFICATION DESCRIPTION	FW6000 Model
<i>Tractor Power Requirement (Minimum)</i>	80 HP
<i>Method of Attachment</i>	Drawbar
<i>Splitter Gearbox Power</i>	140 HP
<i>Centre/Wing Gearbox Power</i>	100 HP
<i>Cutting Width</i>	6.09m
<i>Machine Width in Work Position</i>	6.35m
<i>Machine Width in Transport Position</i>	2.56m
<i>Machine Height in Transport Position</i>	2.77m
<i>Overall Machine Length</i>	5.95m
<i>Machine Weight</i>	3497 kg
<i>Cutting Capacity (Maximum)</i>	50mm
<i>Cutting Height (Minimum / Maximum)</i>	25mm / 400mm
<i>Blade Tip Speed (Center Cutting Unit)</i>	4198m/min
<i>Blade Tip Speed (Wing Cutting Units)</i>	4296m/min
<i>Wing Flex</i>	100°up / 22°down
<i>Blade Overlap</i>	150mm
<i>Cutting Units</i>	3
<i>Wheels</i>	8
<i>Tyre Size</i>	200/60 14.5 x 10 ply
<i>Tyre Type</i>	Duro-rib
<i>Recommended Tyre Pressure</i>	30 psi
<i>Shredder Blade Kit</i>	Optional

GENERAL ARRANGEMENT

Location of Components

The illustrations below show the location of the machine's major components – refer to the following page for key to components.

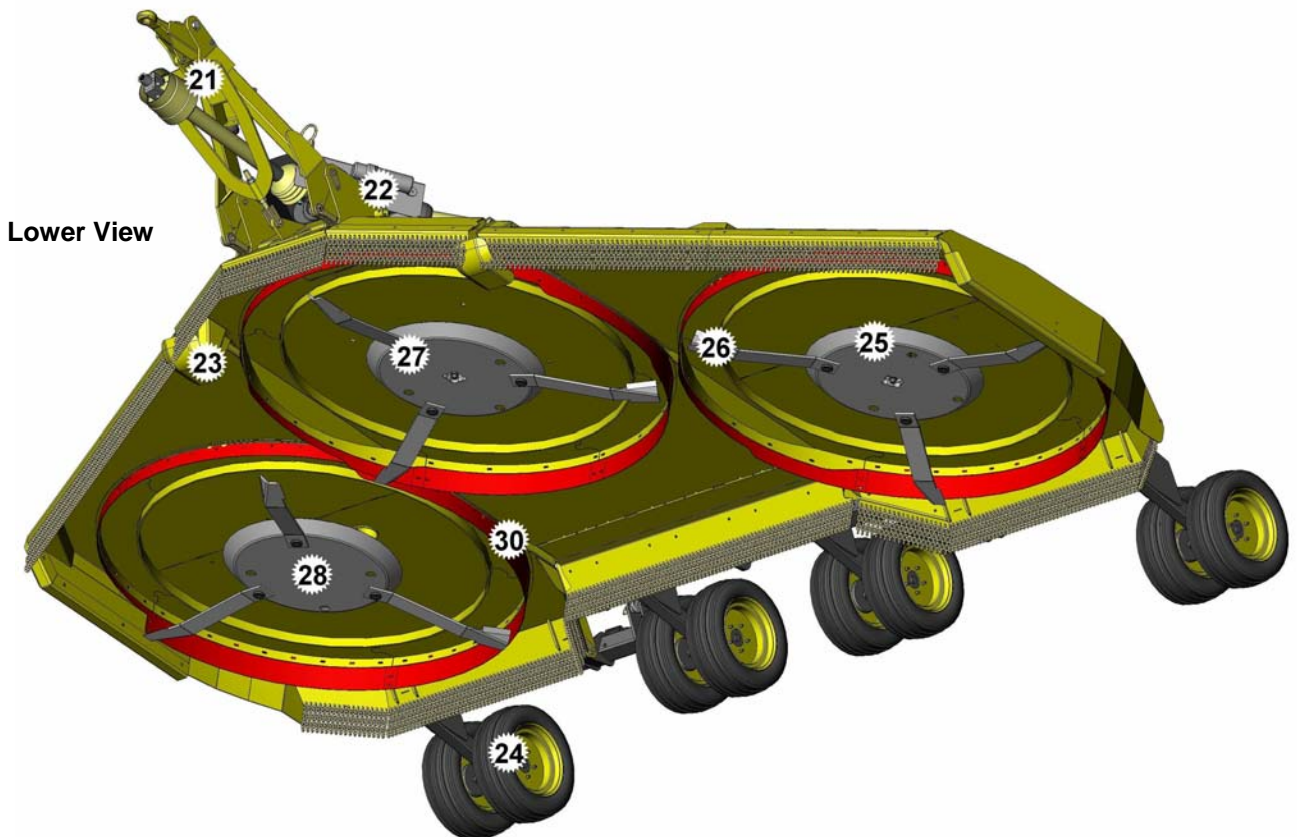
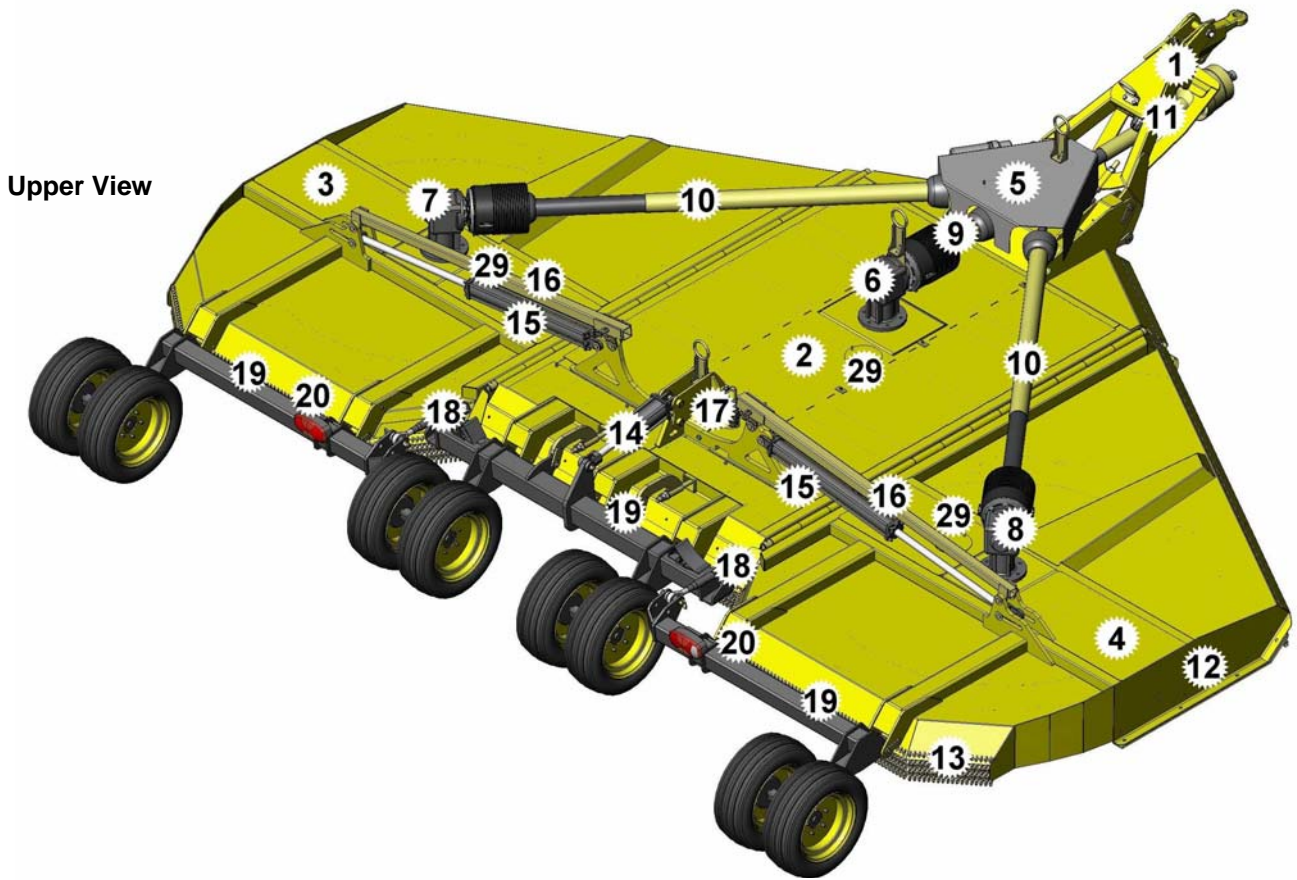

KEY:

- | | |
|--|---------------------------------------|
| 1) Hitch Bracket (<i>High Hitch shown</i>) | 16) Transport Support Arms |
| 2) Centre Deck | 17) Suspension |
| 3) L/H Wing | 18) Wing Levelling Adjusters |
| 4) R/H Wing | 19) Axle |
| 5) Divider Gearbox | 20) Rear Lighting |
| 6) Centre Gearbox | 21) Support Leg (<i>High Hitch</i>) |
| 7) L/H Outer Gearbox | 22) Literature Holder |
| 8) R/H Outer Gearbox | 23) Skid Shoe |
| 9) Centre Driveshaft | 24) Wheel & Hub Assembly |
| 10) Outer Driveshafts | 25) Blade Pan |
| 11) PTO Shaft | 26) Blade |
| 12) Skid | 27) Blade Bolt |
| 13) Chain Guarding | 28) Blade Pan Bolt |
| 14) Height Adjustment Ram | 29) Access Cover (<i>Blade Nut</i>) |
| 15) Wing Lifting Rams | 30) Baffles |

HITCH ATTACHMENTS

The illustrations below show the two types of hitch attachments available for the FW6000.

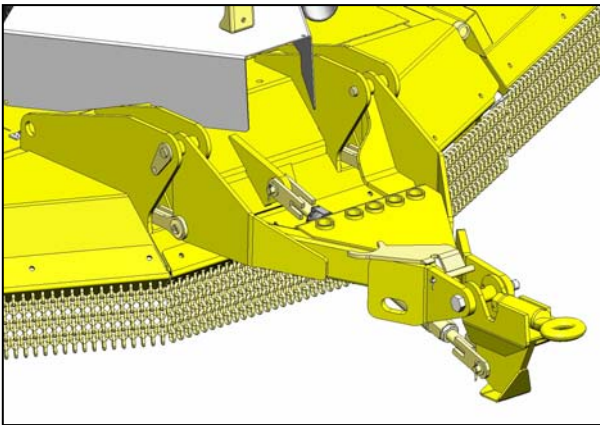

LOW HITCH ATTACHMENT

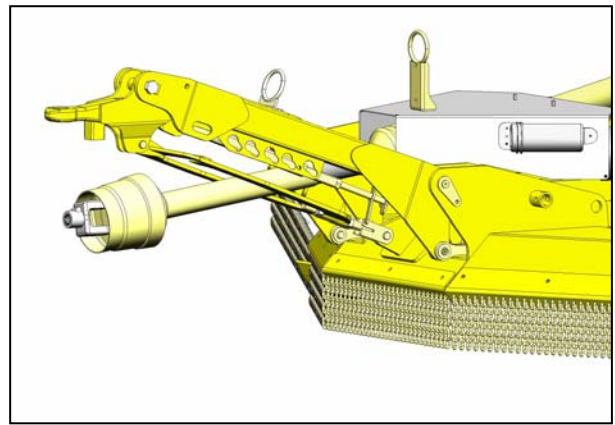

HIGH HITCH ATTACHMENT

NOISE

The equivalent daily personal noise exposure from this machine, measured at the operator's ear, is within the range of 80-85dB when used in conditions where the load fluctuates between zero and maximum. This applies when the machine is attached to a tractor fitted with a quiet cab and used in accordance with the operating instructions in a generally open environment. At equivalent daily noise exposure levels of between 85 and 90dB, suitable ear protectors are recommended.

MACHINE DIMENSIONS

Length & Width in Work Position

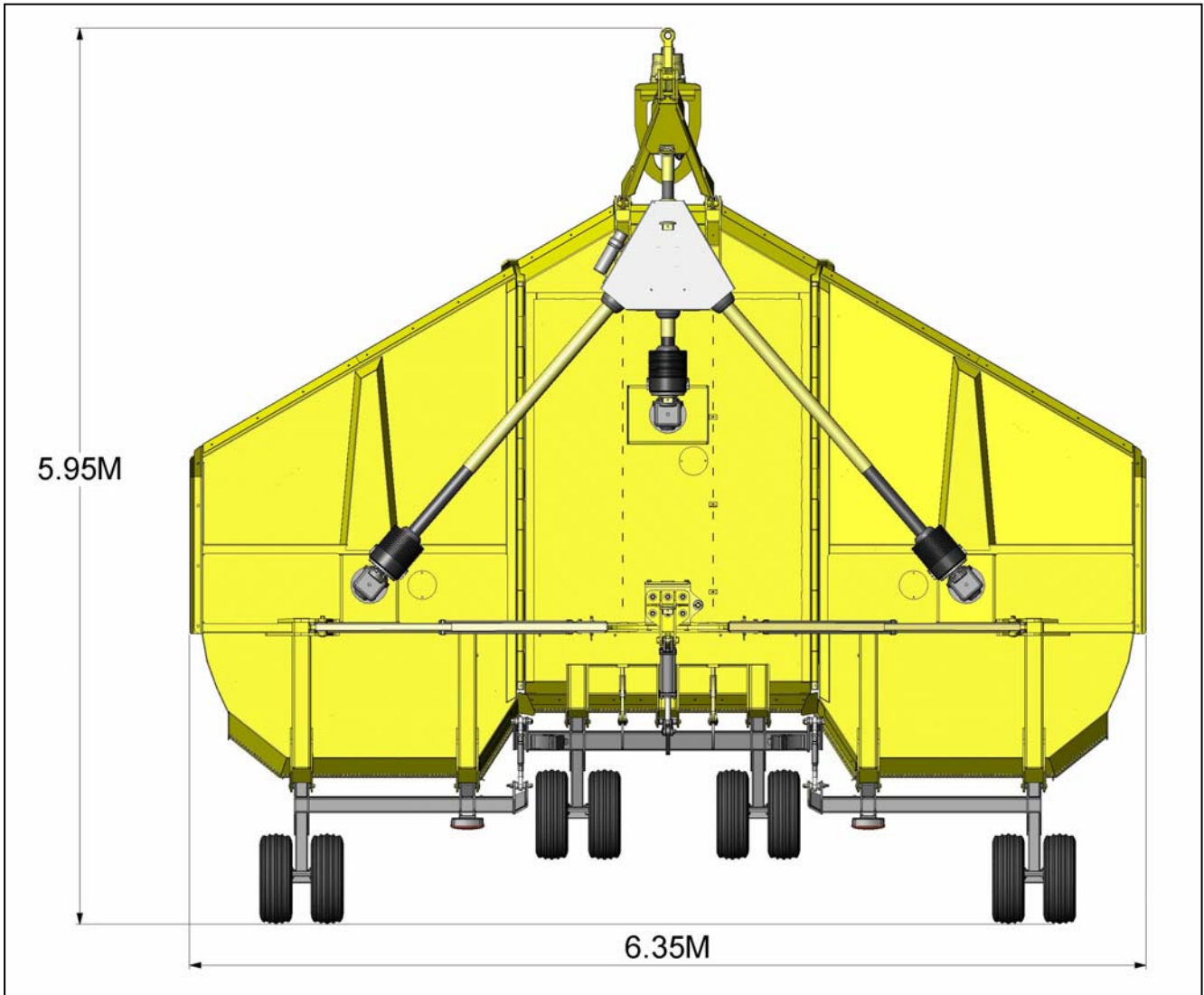

Cutting Height

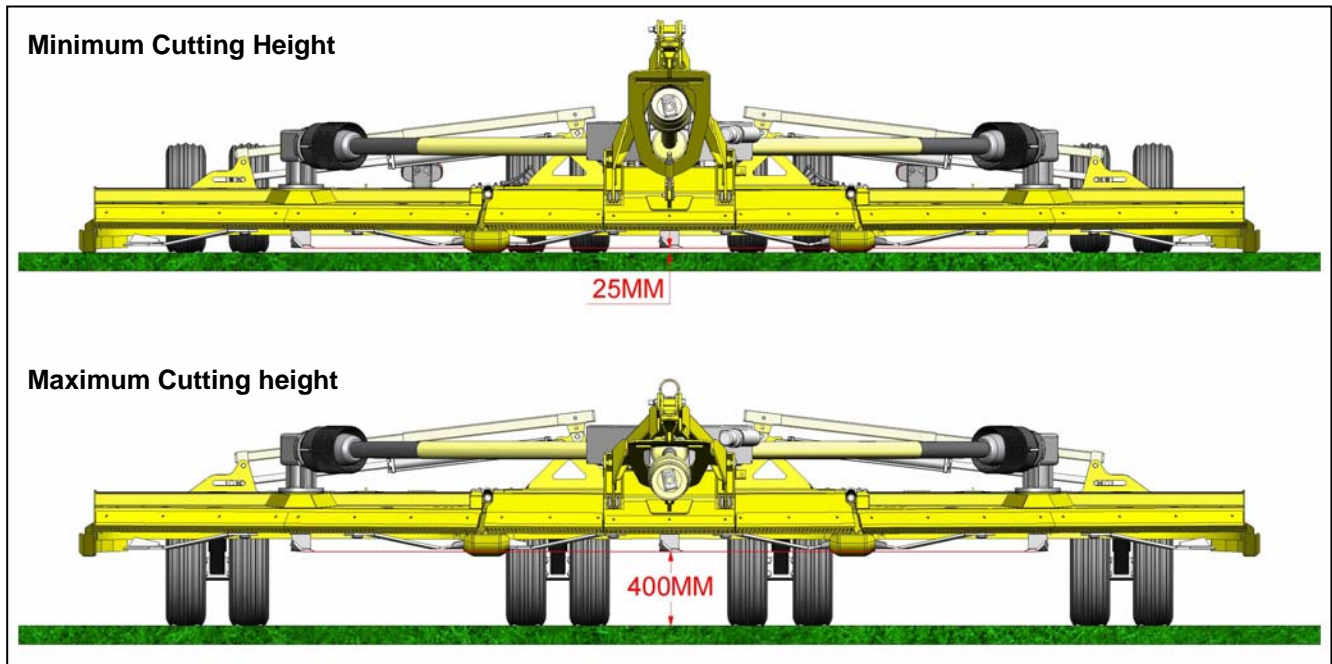

Wing Flex - Normal Working Conditions

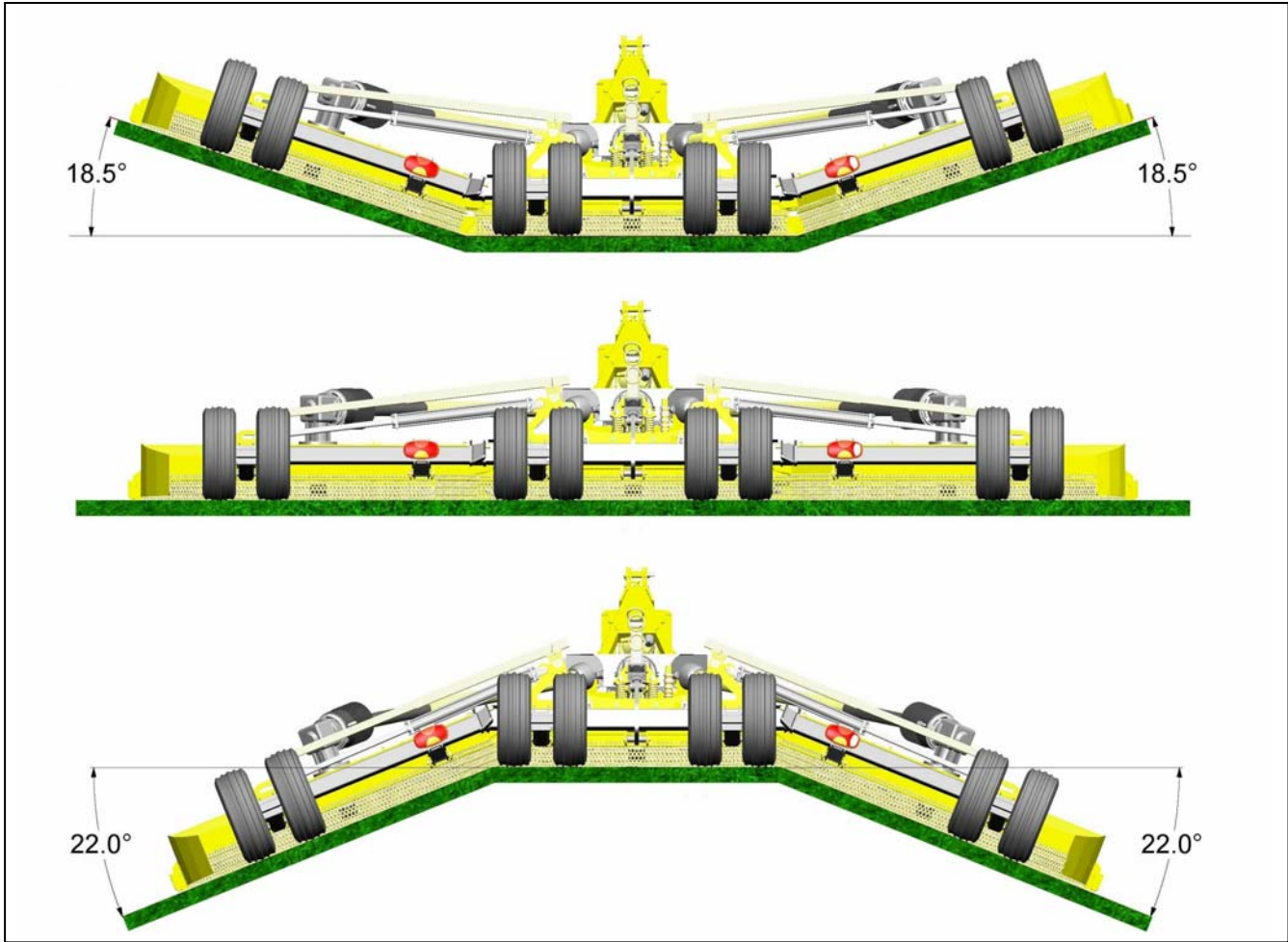

Transport Height & Width

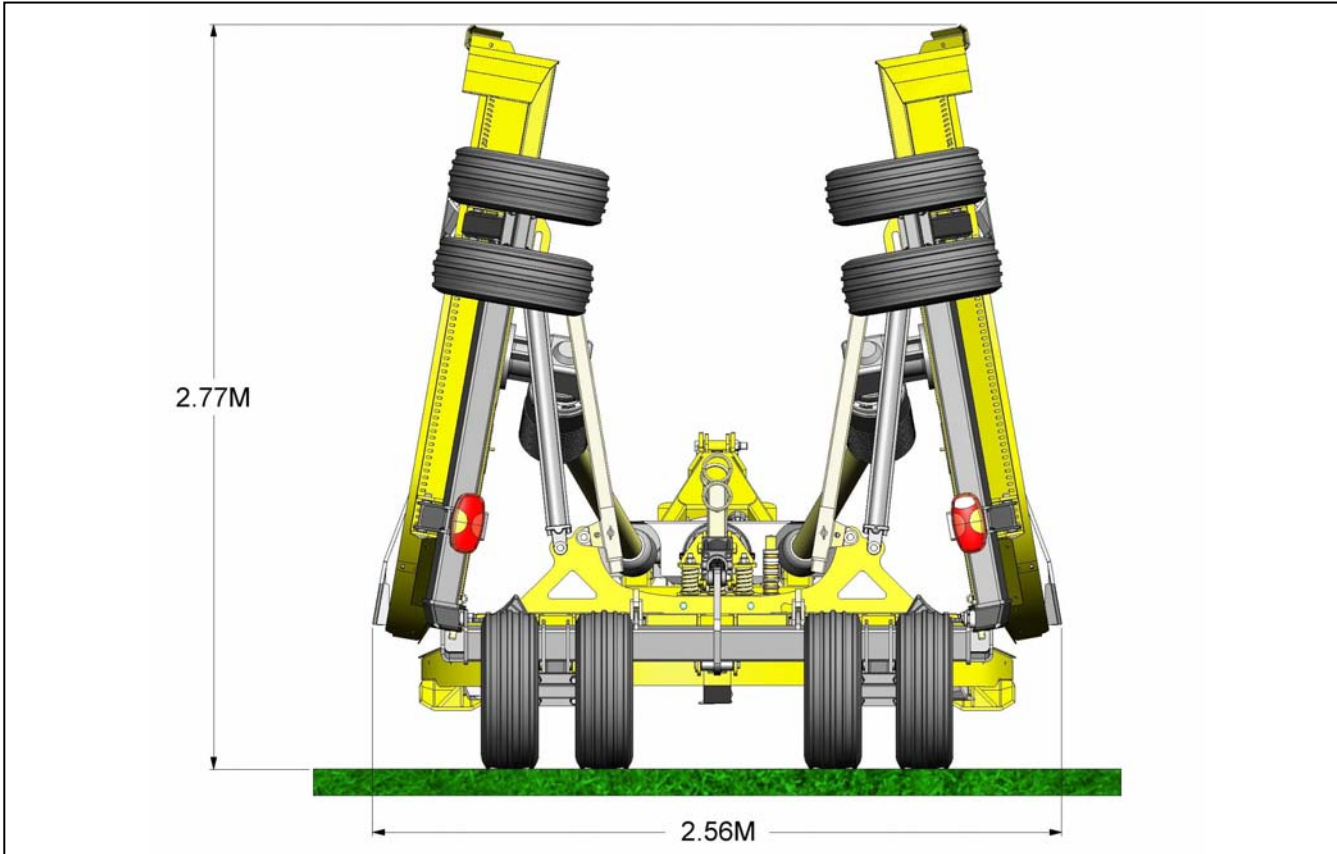

SAFETY SECTION

Read, understand and follow the safety messages - serious injury or death may occur unless care is taken to follow the warnings and instructions given in the safety messages.

CAUTION! The lowest level of Safety Message; warns of possible injury.

WARNING! Serious injury or possible death.

DANGER! Imminent death/critical injury.

Never operate a tractor or any machinery until you have read and completely understood the machine's manual, the tractor's operation manual, and are fully conversant with all safety messages found in the manuals and those displayed on the tractor and implement.

DANGER! DO NOT attempt any maintenance of or adjustment to the machine while it is running. Before carrying out any work on the machine follow the instructions below:

- a). WINGS MUST BE LOWERED TO THE GROUND OR TRANSPORT BARS FITTED AND SECURED.
- b). WHEELS CHOCKED.
- c). PUT THE PTO OUT OF GEAR.
- d). STOP THE TRACTOR ENGINE AND REMOVE THE KEY.

WARNING! The operator and all support personnel must wear the appropriate safety clothing i.e. safety glasses and safety shoes at all times for protection from injury by objects thrown from the machine.

DANGER! Never allow passengers especially children to ride on the tractor or implement. Falling off can kill.

DANGER! Do not mount or dismount the tractor or machine while it is moving. Mount or dismount only when stopped – falling off can kill.

DANGER! At all times ensure that the PTO shaft guard is in position, securely fitted and in good condition and that the tractor PTO shaft shield is fitted.

CAUTION! Replace the PTO shaft guard if any of the following are evident:- guard cracked or damaged any part of the PTO shaft exposed. Ensure the PTO shaft guard is free to rotate and the anti-rotation chains are securely fitted and effective.

WARNING! Ensure that the correct guards are properly fitted to the machine and tractor at all times and check that they are in good condition. Ensure you have the correct guards fitted for the type of operation being performed. Missing or damaged guards must be replaced immediately.

- DANGER!** **AVOID WIRE.** It can be extremely dangerous if wire catches in the blades of the machine, and every care must be taken to ensure this will not happen. Inspect the working area before commencing. Remove all loose wire and obstructions and clearly mark those that are fixed so that you can avoid them. Any unusual noise from the cutting unit area indicates that the blades may have been fouled by an obstruction. A visual indication that wire has become entangled may be a sudden movement of the vegetation ahead of the machine. In any such event STOP the tractor engine INSTANTLY. On no account move the machine until blades have completely stopped. When the machine has stopped inspect it and remove any obstruction that may be present. If working under a raised machine ensure that it is safely supported. Before working on the machine always stop the tractor engine and remove the ignition key.
- WARNING!** While the tractor is running all personnel should keep well clear of the area around the machine as there are numerous crushing, shearing, impact dangers caused by the machine operation.
- DANGER!** Do not operate with wings raised off the ground. Operating with the wings raised exposes the blades and can cause objects to be thrown and there is also danger of entanglement in or being hit by rotating blades.
- DANGER!** Do not work under a wing in the raised position unless it is supported on blocks or propped. A sudden or inadvertent fall by one of these components could cause serious injury or even death.
- DANGER!** These machines are capable under adverse conditions of throwing objects great distances at high velocity. CHECK the blades for wear and the attachment bolts for tightness every day during work .A few moments whenever the machine is stopped, e.g. whenever removing obstructions, will help reduce blade wear or loss.
- DANGER!** Keep your forward speed to a level appropriate to the operating conditions. High-speed manoeuvres are very dangerous, particularly on uneven ground where there is risk of overturning.
- DANGER!** Keep a careful watch for passers-by who may inadvertently get in the way of cut material being thrown from the machine. These machines are capable under adverse conditions of throwing objects great distances at high velocity. Stop the blades until all people are well clear.
- WARNING!** Extreme care should be taken when operating near loose objects such as gravel, rocks, wire, and other debris. Inspect the area before mowing. Foreign objects should be removed from the site to prevent machine damage and/or bodily injury or even death. Any objects that cannot be removed must be clearly marked and carefully avoided by the operator. Stop mowing immediately if blades strike a foreign object. Repair all damage and make certain the blade and carrier are still balanced before resuming cutting operations.
- WARNING!** Transport the machine only at safe speeds. Serious accidents and injuries can result from operating this equipment at unsafe speeds
- DANGER!** When the wings are folded for transport, the centre of gravity is raised and the possibility of overturn is increased. Turn slowly and with extra care on hillsides.

Overturning the mower could cause the mower to overturn the tractor and vice versa. Never fold wings on a hillside, the mower may overturn.

WARNING! Do not transport unless wings are well secured in the transport position. Wings that are not well secured can fall during transport, causing serious damage to the tractor and mower and possibly causing the operator or passers by to be injured or killed.

WARNING! Release hydraulic pressure from the rams before attempting maintenance. Lower the machine to the ground and lower the wings or securely block up, disengage the PTO and turn off the engine.

DANGER! Do not operate this Equipment with hydraulic oil leaking. Oil is expensive and its presence could present a hazard. Do not check for leaks with your hand! Use a piece of heavy paper or cardboard. High-pressure oil streams from breaks in the line could penetrate the skin and cause tissue damage including gangrene. If oil does penetrate the skin, have the injury treated immediately by a physician knowledgeable and skilled in this procedure.

WARNING! Periodically inspect all moving parts for wear and replace when necessary with authorised service parts. Look for loose fasteners, worn or broken parts, and leaky or loose fittings. Make sure all pins have cotter pins and washers. Serious injury may occur from not maintaining this machine in good working order.

WARNING! When unhitching the mower select a firm level site on which to park it - lower machine to the ground fully (fit and adjust the hitch support prop on high hitch machines) and 'chock' the wheels. Remember to disconnect hydraulics, lighting plug and PTO shaft (use the PTO support) before driving the tractor away. Stow hoses and electrical cable neatly off the ground to avoid moisture or dirt contamination.

WARNING! Never attempt to lubricate, adjust, or remove material from the Implement while it is in motion or while tractor engine is running. Make sure the tractor engine is off before working on the Implement.

Emergency Stop

To stop the blades in an emergency use the tractor stop control. The use of the tractor stop control must only be done in an emergency. Its use to stop the machine can cause damage. After an emergency stop of the machine; ensure that the PTO is disengaged before restarting the tractor.

Safety Decals

Safety decals are located on various points of the machine. They can be identified by the yellow upper panel depicting the hazard, and the lower white panel indicating means of avoidance or precautions to be taken. These decals have no text. It is essential that all operators and personnel associated with the machine fully understand their meanings, which are shown on the following pages.

Any safety decals that are found to be missing should be replaced at the earliest possible opportunity.

SAFETY DECALS



STOP ENGINE AND REMOVE KEY BEFORE SERVICE OR MAINTENANCE

DANGER OF ROTATING BLADES - KEEP CLEAR

DANGER - DO NOT OPERATED MACHINE WHEN RAISED



DANGER OF ENTANGLEMENT KEEP CLEAR OF MACHINE WHEN IN OPERATION

KEEP ALL NUT TIGHT

READ INSTRUCTION MANUAL BEFORE OPERATION



DO NOT WORK UNDER UNSUPPORTED MACHINE

DANGER OF CRUSHING STAY CLEAR ZONES

DANGER FROM THROWN OBJECTS KEEP CLEAR

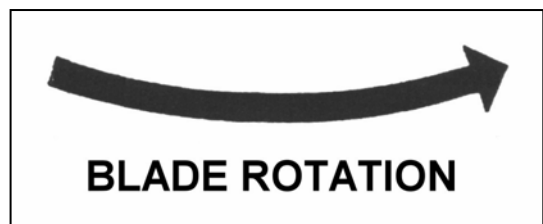
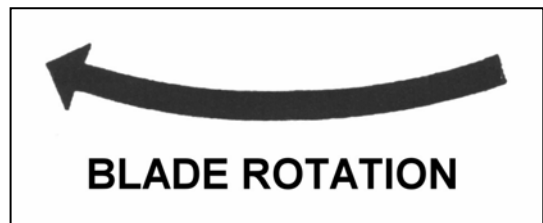

BLADE ROTATION DECALS



PTO SPEED

INSTALLATION

Preparing the Tractor

A few simple tasks will be necessary to prepare your tractor for use with the rotary mower.

- Remove cap from PTO shaft.
- Ensure tractor PTO guard is in place.
- Set tractor tyres out to 1500mm (60") dimension between tyres.

Fitting Machine to Tractor

WARNING: Avoid injury - ensure there are no bystanders between tractor and machine when coupling machine to the tractor.

Keep onlookers at a safe distance from the machine.

Ensure the wheels are chocked to avoid rolling.

MOUNTING MOWER TO TRACTOR

- Reverse tractor squarely to the machines hitch ensuring that the hitch is at the correct height for attachment.
- Connect tractor and machines hitches and close/lock in position. *NOTE: For machines fitted with a high hitch a choice of operational modes are available, refer to following pages for high hitch usage information.*
- Apply parking brake and switch off the tractor's engine.
- Connect machines quick release hydraulic couplings and rear lighting connection to the tractor services.
- On **high hitch models only** remove parking prop and place in stowage position on the hitch – *see illustration on following page.*
- Connect PTO shaft to tractors PTO output.
- Stow wheel chocks in stowage location on rear axle – *machine may need to be drawn forward slightly to release chocks from wheels.*
- Check PTO strap is adjusted to give sufficient clearance around the PTO shaft in all height positions.

HIGH HITCH PARKING PROP – Parking & Stowage Positions

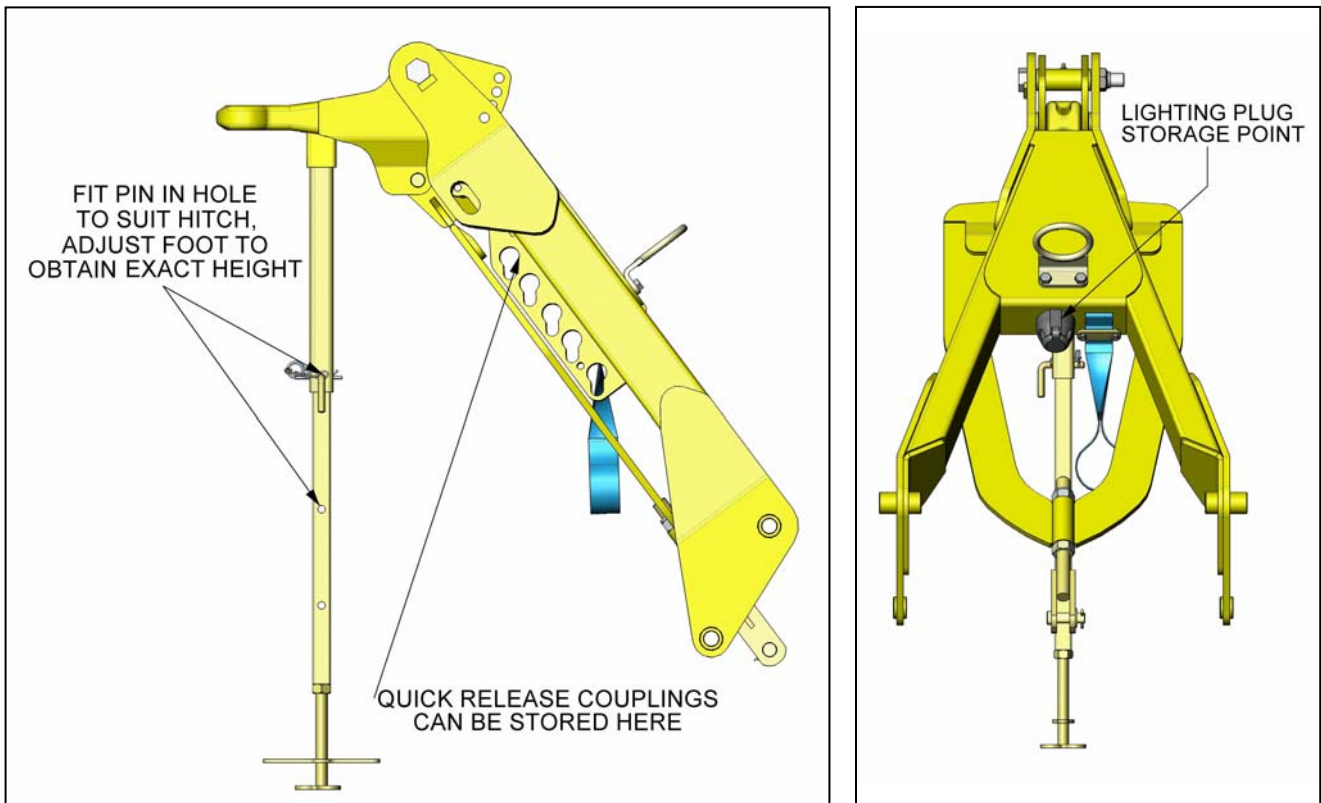

High Hitch Parking Prop – Parking Position & Lighting Plug Storage

High hitches are supplied with a parking prop that should always be used to support the hitch when the machine is 'parked up' and disconnected from the tractor – the diagram above left shows the location of the prop in the parked position – always chose a site on which to park the machine that is firm and level to avoid the possibility of the prop sinking into the ground, if necessary place a block or slab under the foot of the prop to spread the load.

A lighting plug storage point is located on the rear of the hitch; the lighting plug should be stored here once disconnected from the tractor's power supply in order to protect the electrical contacts from possible accidental damage and moisture. For similar reasons, storage points for the quick release hydraulic couplings are located on the left side of the hitch – see *diagrams opposite and above*.

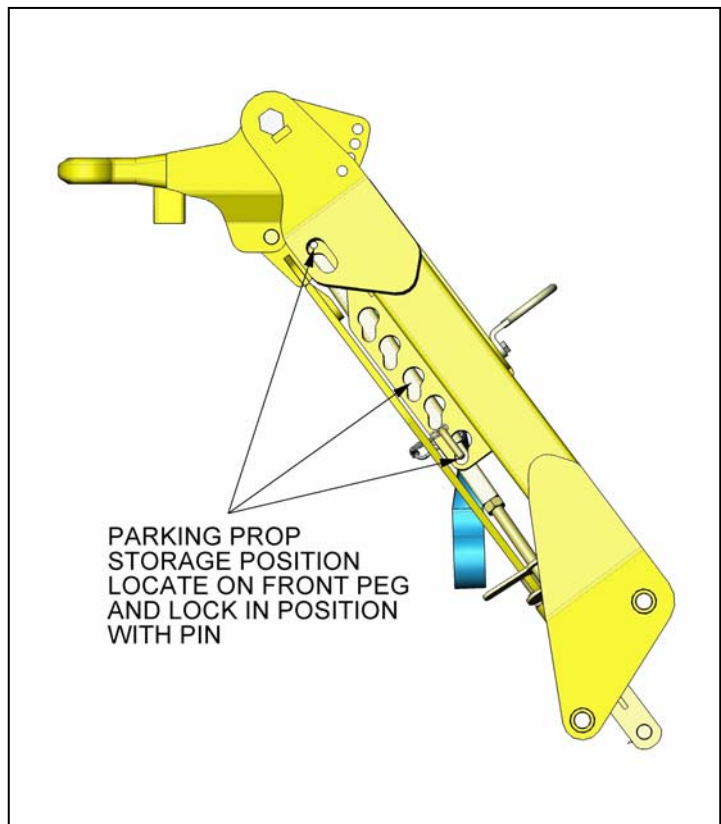

High Hitch Parking Prop – Stowage Position

When the machine is attached to the tractor and during work the parking prop is stowed in the storage position beneath the neck of the hitch as illustrated in the diagram above.

HIGH HITCH – Operational Modes

The High Hitch for the FW6000 may be used in either one of two available modes, these are; (1) Parallel Mode and (2) Fixed Eye Mode – the choice will primarily be dependant on either the specifications of the towing vehicle and/or the working conditions of the machine. It is important to note at this point that whichever mode is adopted the components of the alternative mode must not be attached to the hitch assembly (A) – refer to diagrams below.

In parallel mode the parallel link (B) is attached to hitch assembly (A) and the nuts and bolts (C) that lock the top hitch in the fixed eye mode are removed to allow the top hitch to ‘float’, in the same manner if fixed eye mode is chosen, the parallel link (B) must be disconnected and removed from the hitch assembly (A) and nuts & bolts (C) replaced in order to ‘lock’ the top hitch. Under no circumstances should the parallel link be attached and operated with the top hitch locked - failure to observe this will result in damage to the machine.

The diagrams below show high hitch components and their application for each option.

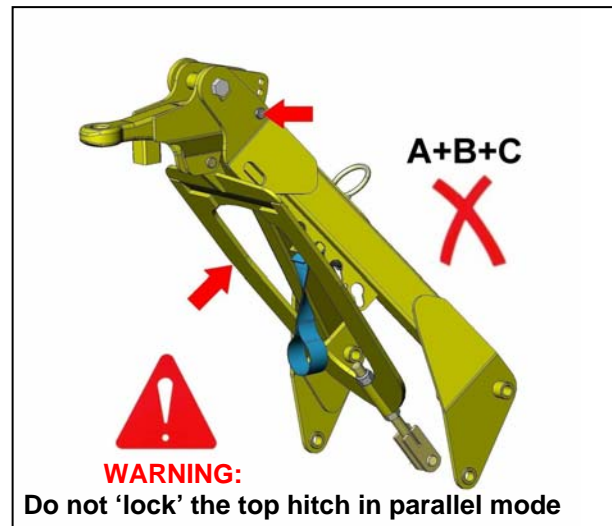
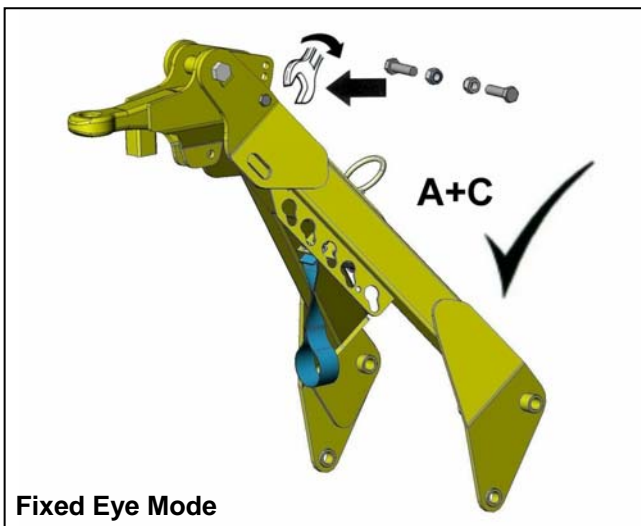
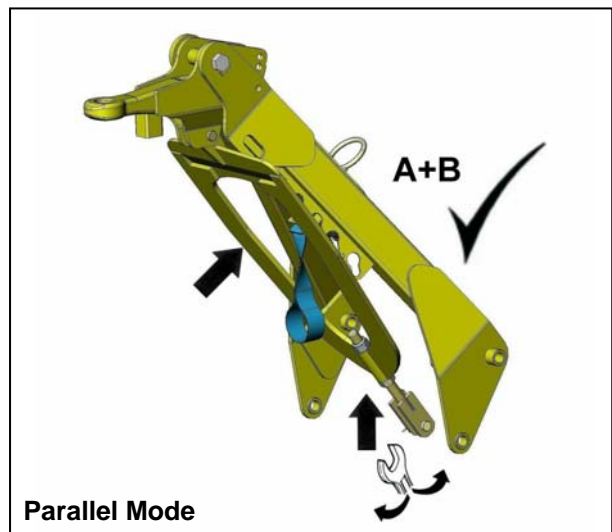
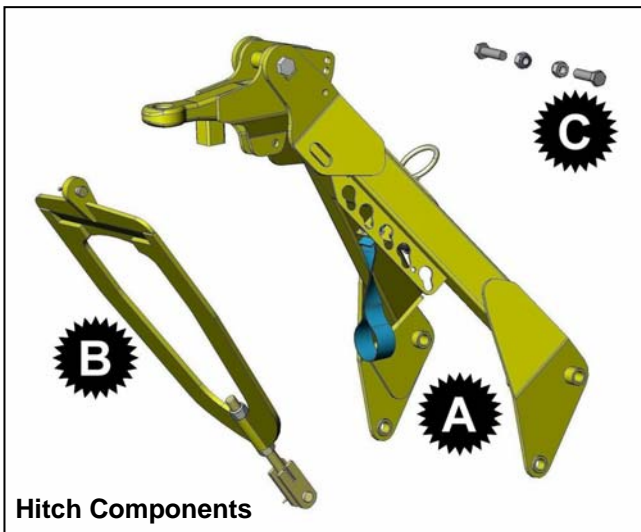

Key to components:

- A) High Hitch Assembly
- B) Parallel Link
- C) Nuts & Bolts (Top Hitch locking)

PTO Shaft

With the machine attached to the tractor's drawbar, proceed to connect the PTO as follows:

- 1 Slide the collar back and simultaneously push driveline yoke into PTO shaft on tractor until engaged.
- 2 Move yoke back and forth to make sure yoke is locked in plate - *QS-type collars will rotate 360° when balls are correctly located.*

WARNING: A loose yoke could slip and cause personal injury or damage to mower. When attaching driveline yoke to tractor PTO shaft, it is important that the slide collar is fully forward and seated on yoke.

Due to many different makes and sizes of tractor to which mowers may be fitted, a nominal length PTO shaft is supplied with the machine. In some cases it may be found that this PTO shaft is too long and will have to be shortened.

IMPORTANT: MINIMUM ENGAGEMENT OF PTO IS 400MM IN THE WORKING POSITION - THIS MEASUREMENT MUST BE TAKEN INTO ACCOUNT WHEN SHORTENING THE PTO SHAFT.

Before fitting PTO shaft to tractor, grease the sliding drive shafts and bearing units.

- a Fit PTO to tractor ensuring locking peg on the splined coupling is fully engaged.
- b Attach PTO guard check chains to tractor and machine.

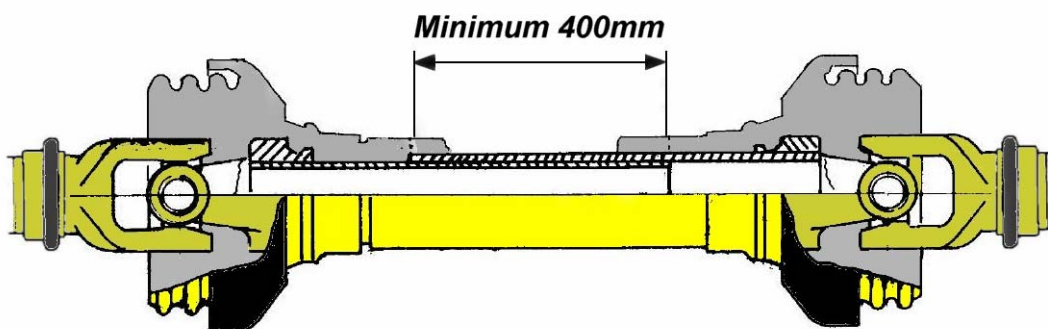

SAFETY CHAINS

When towing implements on the highway use a safety chain with a tensile strength that is equal to or greater than, the gross weight of the implement being towed by the tractor. This will control the implement in the event of the machine becoming unhitched.

After attaching the safety chain, make a trial run by driving the tractor to the right and to the left for a short distance to check the safety chain adjustment. If necessary, re-adjust to eliminate tight or loose chain.

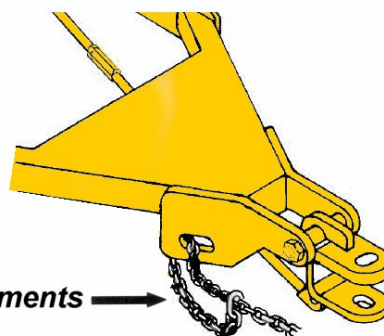

CV DRIVELINE CHECK PROCEDURES

The main driveline to tractor is equipped with a special constant velocity (CV) joint that allows the joint to run smoother with no vibration even at joint angles up to 80°. This joint will operate and perform satisfactorily as long as it is not subjected to conditions, which abuse it or go beyond its operating limits.

The constant velocity joint must be greased daily at 8 hour intervals - see *maintenance section*.

Failure to lubricate as instructed will cause rapid wear and failure of operating components of joint. The constant velocity joint must not be subjected to a joint angle greater than 80°, (see *diagram below*), for short duration, or 25° maximum for continuous operation.

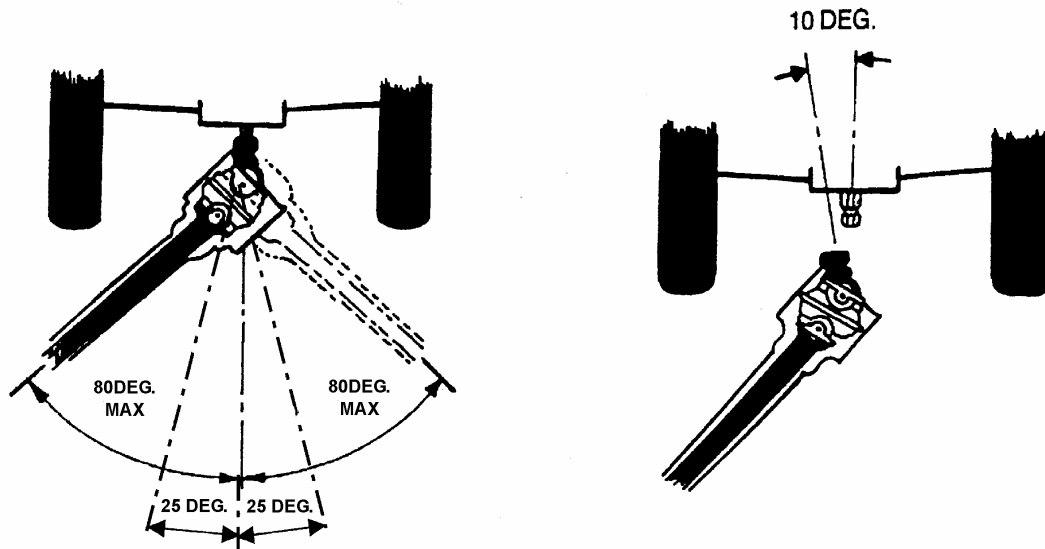

To check maximum joint angle, connect cutter to tractor. Do not connect driveline at this time. Start tractor and make a maximum turn to left until tractor tyre almost contacts frame. Then check joint by holding driveline yoke above PTO shaft and then angle driveline yoke until it stops. There should be approximately a 10-degree difference between centre line of yoke and PTO shaft, (see *diagram*), If not, check drawbar length and shorten if necessary. The constant velocity joint must not be subjected to conditions where telescoping tubes bottom out. Check this condition using driveline length check procedure.

NOTE:

If the driveline will not connect because it does not have enough clearance, check to see if the drawbar can be lengthened or alternatively cut the driveline shield and tube lengths to provide adequate clearance.

DRIVELINE LENGTH CHECK PROCEDURE

WARNING A loose shaft could slip off and result in personal injury or damage to mower. When attaching PTO yoke to tractor PTO shaft, it is important that spring activated locking collar slides freely and locking balls are seated in groove on PTO shaft – Note: QS-lock is fully engaged if collar can be rotated freely.

WARNING Before operating mower, check to make sure the driveline will not bottom out or become disengaged.

Disengage the driveline from the tractor PTO shaft.

Slide the driveline together until it “bottoms out” solidly. Extend shaft 40mm, then apply coloured tape level with outer tube shield. This shows maximum shaft length.

Slide the driveline apart until $\frac{1}{2}$ PU length of inner shaft shield is exposed - see *diagram*, apply coloured tape level with outer tube shield as before. This then indicates maximum shaft length.

Re-attach driveline to tractor PTO shaft.

With the PTO NOT TURNING, (disengaged), slowly drive the tractor with mower attached through the most severe terrain conditions expected and watch shaft movement. The end of the outer shield should always be located between the two rings of tape.

Check position which places driveline at maximum extended length and at minimum compressed length. The minimum compressed length should always maintain 40mm ($1\frac{9}{16}$ ") clearance, if not, shorten as shown in diagram.

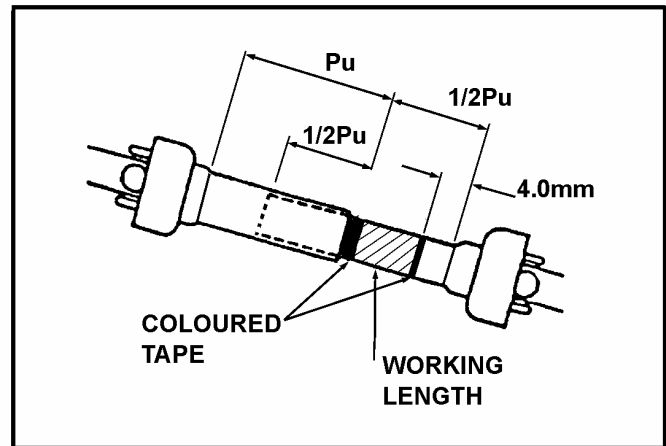

Driveline in maximum extended position

If the driveline cannot be shortened and still maintain $\frac{1}{2}$ PU dimension engagement, when at maximum extended length, then the operator should be aware of it, so the operator can recognise the terrain conditions that might cause problems (avoiding possible damage by disconnecting driveline from tractor) and cross the terrain in a different manner. If driveline is shortened, re-apply the coloured tapes and re-check length, as previously.

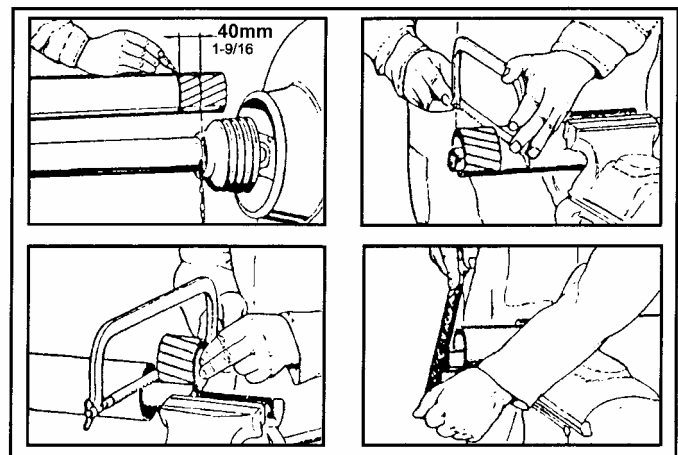

NOTE: See special instructions for rough terrain operation.

HYDRAULICS

The hydraulic hoses connect to 2 pairs of spools on the tractor's auxiliary hydraulics allowing independent control of both the deck height and the wings for transport/work position. Float is only required for the wings and should be selected during work – this will allow the mower sections to follow the contour of the land. *Additional information on this subject may be obtained by contacting the McConnel Service Dept. or your local dealer.*

Keep hoses and couplings free from contamination. Never leave a disconnected end of hose open. Ensure the hoses are supported and not allowed to come into contact with the drivelines.

In case of valve or cylinder malfunction, contact your local dealer. If it becomes necessary to remove the piston from the cylinder, apply a few drops of 'Loctite No. 227' to the nut before replacing.

CLUTCH ADJUSTMENT

Three slip clutches are fitted in order to protect both machine and tractor components. Machines are supplied set to low torque therefore **clutches must be adjusted prior to first use** – refer to the Maintenance Section for details of clutch settings.

IMPORTANT

WORK & TRANSPORT POSITIONS

Wing axles are attached to the mainframe axle on both sides with adjustable links – there are 2 positions available for the attachment of these links, one for work mode and one for transportation of the machine - see *diagram opposite*.

It is vital that the links are connected at the correct hole position for each specific function – **failure to observe this will result in damage to the machine and/or adjustable links.**

Moving from Work to Transport Position

The procedure for moving the machine between work and transport positions is as follows:

Always raise and lower the wings of the machine with the adjustment link attached in the work position hole. Once the wings have been raised they should be 'fixed' in the upright position using both the transport support bars. Raise the machine to give tyre and axle clearance and fit split collar stops to the height ram, the adjustable link can then be removed from the work position hole allowing the wing axles to be pivoted inwards.

The adjustment link must then be reattached to the transport position hole – see *diagram above*. Moving back into the work position is a reversal of the above procedure.

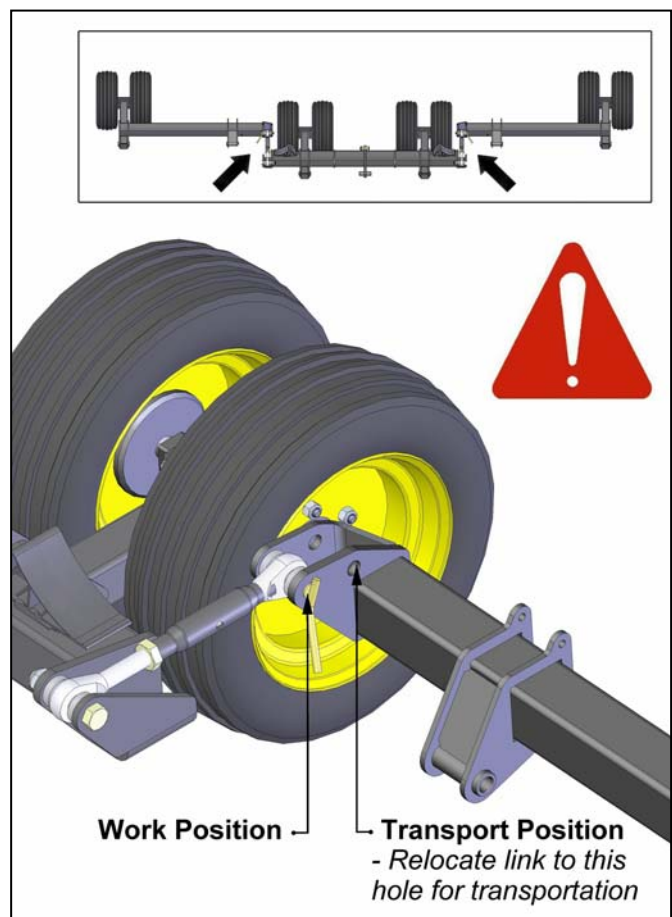

WARNING

Never attempt to lower the wings with the adjustable link in the transport position.

DISMOUNTING MOWER FROM TRACTOR

- Park the mower on a firm level site – lower front of mower to the point where the front skids of the centre deck are resting on the ground. Close the axle ram fully so rear of machine is in the lowest possible position.
- Apply parking brake, switch off the tractor's engine and release pressure in hydraulic spools.
- Place wheel chocks securely at rear of the main deck wheels.
- Remove PTO shaft from tractor ensuring PTO strap is at a suitable height to hold the shaft clear of the ground.
- On high hitch models only remove parking prop from its stowage position on the hitch and locate it in its support position under the hitch bracket – adjust the prop so that it is safely supporting the hitch and secure in position.
- Disconnect the machine's quick release couplings and rear lighting connection.

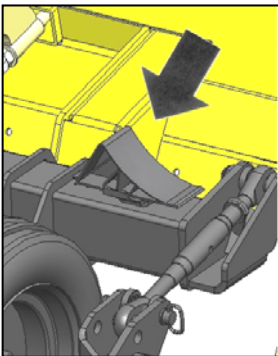
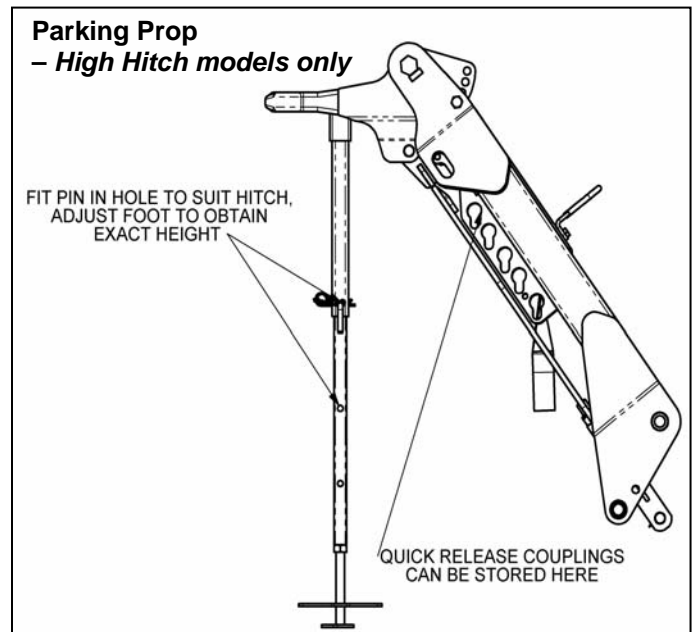

Special brackets for stowage of the mowers wheel chocks are located at each end of the centre axle frame – in the interest of safety the rear centre axle wheels should be chocked at all times when the machine is not in use and disconnected from the tractor, and during storage of the machine.

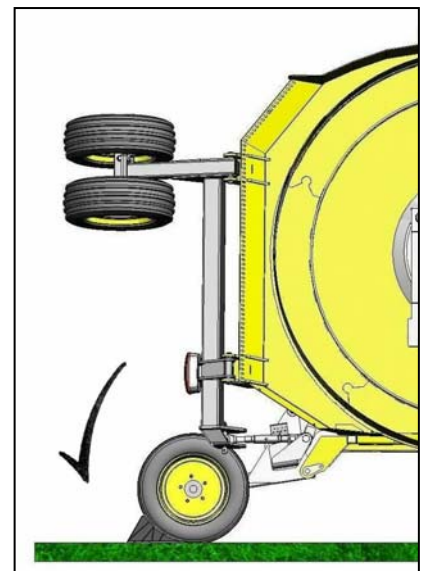
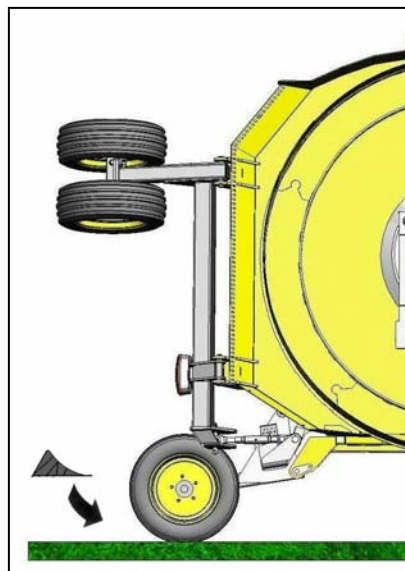

OPERATION

HEIGHT OF CUT

In order to achieve maximum cutting efficiency whilst providing a uniform cut the mower should be operated with the rear of the machine set slightly higher than the front; 12 - 20mm ($\frac{1}{2}$ " - $\frac{3}{4}$ ") is the recommended height difference setting.

IMPORTANT: Avoid very low cutting heights; striking the ground with the blades will produce damaging shock loads that will cause damage to the mower and drivelines.

LEVELLING THE MOWER

The diagram below shows the location of the Levelling System components.

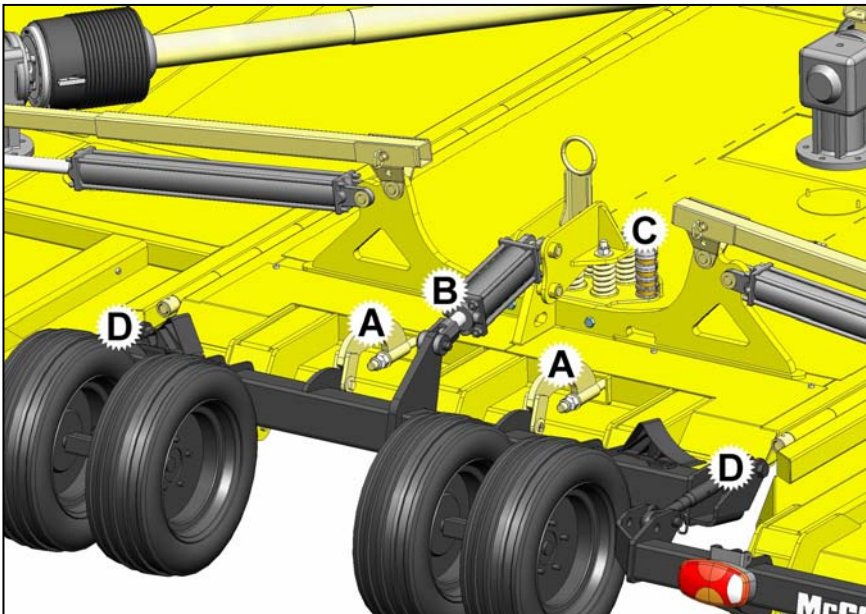

LEVELLING COMPONENTS

- A) Levelling Rod Adjusters
- B) Hydraulic Axle Ram
- C) Split Collars (Storage)
- D) Wing Levelling Adjuster

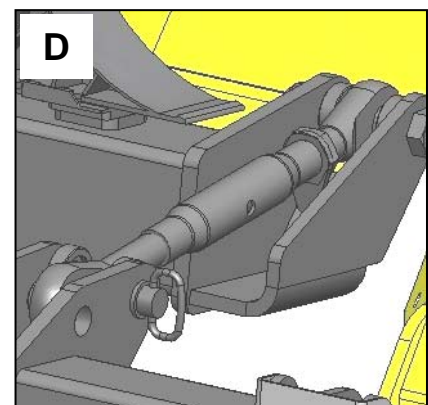
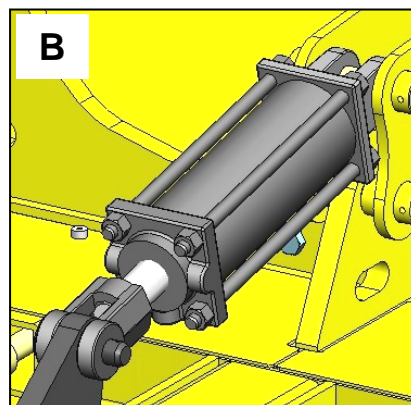
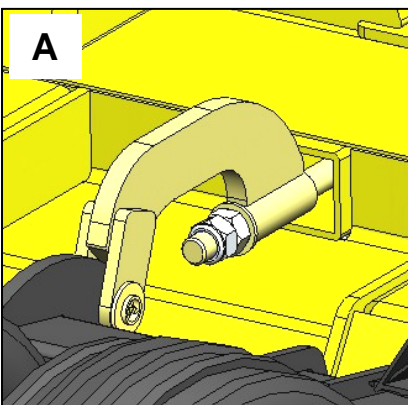
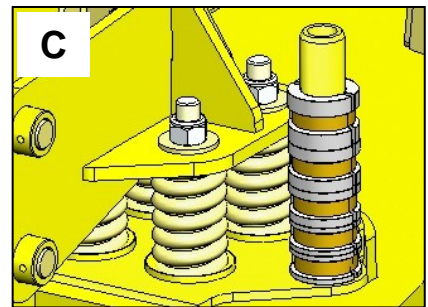

Centre Deck Levelling:

- Position the tractor and mower on a firm level site.
- With front skids resting on the ground, adjust control rod link on front hitch so that the ring or clevis attachment to the tractor is horizontal and parallel to the ground – adjustment will only be possible when the adjuster is not under load.
- Using the centre axle hydraulic ram 'B', raise or lower the centre deck to the approximate cutting height required.

- Level the mowers centre deck (front to rear) by adjusting the levelling rods 'A' that link the hitch to the rear axle – *turning the adjusting nuts anti-clockwise to lengthen the rods will lower the front, turning the adjusting nuts clockwise to shorten the rods will raise the front.*

IMPORTANT: Ensure both levelling rods are adjusted equally to maintain the same length and tension – unequal adjustment may cause the rods to break or bend.

- Once the mower has been correctly levelled, the exact cutting height can be set - use split collars placed on the ram rod of the axle ram to set the height so that once the ram is lowered against the collars the desired cut height is set.

The split collars are supplied in a set comprising of 5 securing clips and 5 (2 part) collars of the following sizes: 1" (x2), 1¼", 1½" & 1¾". When not in use collars can be stored on the stowage pin (C) located on the suspension assembly.

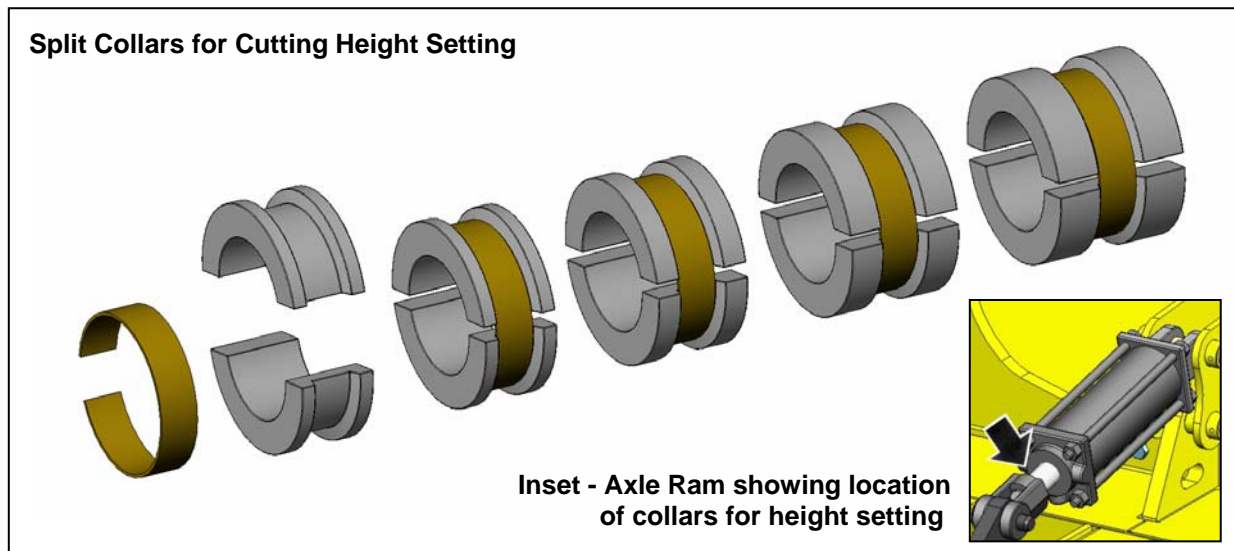

Wing Levelling

Levelling of the wings to the centre deck is achieved by manually rotating the wing adjuster links (D) that connect between the wing and centre axles with the effect of altering their length – shortening the adjuster will lower the wings, lengthening the adjuster will raise the wings.

PRE START CHECKS

Before operating the machine it is advisable to carry out the following Checks.

- a Check that the blades are free of obstructions especially pieces of wire.
- b Check that the blades are in good condition and securely attached
- c Ensure all guards are in position and in a serviceable condition.
- d Examine the work area and remove or identify hidden obstructions, posts and wire etc.

STARTING & STOPPING THE MOWER

Power for operating the mower is supplied from tractor PTO. Refer to your tractor manual instructions for engaging and disengaging the PTO. Always engage to the PTO at low engine rpm. Always operate at recommended PTO speed. Always reduce engine speed to idle rpm before disengaging PTO. Learn how to stop tractor and mower quickly in case of emergency.

IMPORTANT: Stop mower and tractor immediately upon striking an obstruction. Inspect the mower and repair any damage before resuming operation. Do not engage PTO when engine is at full PTO rpm. Always idle engine before disengaging PTO.

WARNING: Avoid personal injury. When attempting to stop a tractor that does not have a live PTO, the momentum created by the blade carrier of a rotary mower can cause the tractor to be pushed forward. DO NOT Operate this mower unless tractor has live or independent PTO.

To commence operation, reduce engine speed and engage the tractor PTO. Before starting to cut, gradually increase engine speed to develop full PTO speed.

DANGER: Chain guards must be installed if operating with people or livestock in the area or close to highways or buildings and in all non-agricultural operations.

Enter the area to cut with the mower operating at PTO speed and, if it becomes necessary to temporarily regulate engine speed during operations, increase or decrease the throttle gradually.

For transportation of the machine, disengage the PTO, raise centre section and raise the wings to full transport height, stop the tractor and install transport bar locking pins.

WARNING: When lowering wings from transport position, be sure all persons are clear of wings. Do not work under wing in raised position unless transport lock bar is in place.

IMPORTANT: Wing hydraulic cylinders should always be controlled by a tractor valve or remote valve which has float detent position which allows wings to float over uneven terrain

CUTTING SPEED

Proper ground speed for cutting will depend upon the height, type and density of material to be cut. Normally, ground speed will range from 2 - 5 mph. Tall, dense material should be cut at low speed while thin medium height material can be cut at a faster ground speed.

WARNING: Do not attempt to raise wings on slopes or banks. Move machine to level area before attempting to raise wings

CUTTING TIPS

Always operate the PTO at recommended rpm when cutting. This is necessary to maintain proper blade speed and to produce a clean cut.

Under certain conditions, tractor tyres may roll some grasses down and prevent them from being cut at the same height as the surrounding area. When this occurs, reduce the tractor ground speed but maintain the PTO rpm. The lower speed will permit grasses to be at least partially rebound and be cut. Taking a partial cut and/or reversing the direction of travel may also produce a cleaner cut.

Extremely tall grass should be cut twice. Raise mower and cut twice the desired height. Cut the second time at desired height at 90 degrees to first pass.

Remember, sharp blades produce cleaner cuts and use less power.

DANGER: Wing sections should be raised only for clearance of obstructions and never for continuous cutting operations. Cutting with wings raised above the ground surface exposes the blades and can cause objects to be thrown from under guards at a very high velocity and can cause property damage, bodily injury or even death!

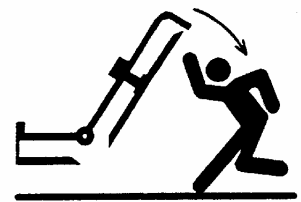

DANGER: DO NOT raise wings with blades rotating.

If you have a condition where you tractor will be going up a steep incline with your mower still on the flat area or coming down the opposite incline, you have a potential problem. The correct preventative measure is to instruct the operator to cross this kind of terrain at an angle - see *diagrams below*. This will reduce the angle between the tractor and the mower. The problem is more likely to occur if the mower is in the raised position while the tractor is turning sharply and going up an incline.

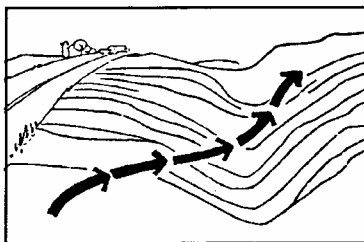

CORRECT: Approach ditch at an angle

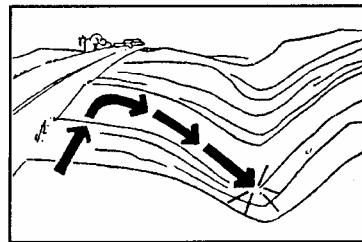

INCORRECT: DO NOT approach ditch straight on

TRANSPORTATION

MOVING INTO TRANSPORT POSITION

For transportation of the mower it is advisable to position the centre deck of the machine as low to the ground as is practical to increase stability. Raise both the wings of the mower using their hydraulic rams – each wing will fold upwards to the vertical position and continue inwards towards the centre of the machine until it is approximately 10° past the vertical position – locate the securing pins in the transport support bars on both sides of the machine to lock the wings in position – *the diagram opposite shows the transport support bar and its securing pin in the transportation position (locked).*

Once the wings have been raised and locked into position the adjustable axle links can be released from their work position by first removing their locking pins and the wheel axles ‘swung’ inwards to reduce the machines transport width - they are retained in position by relocating the adjustable links and locking pins into the transport position hole – *refer to page 17 for diagram relating to this procedure.* The height for transport can be set by fitting the split collar stops on the height ram – *this should be as low as possible.* The machine is now ready for transport – see following page for transportation guidelines.

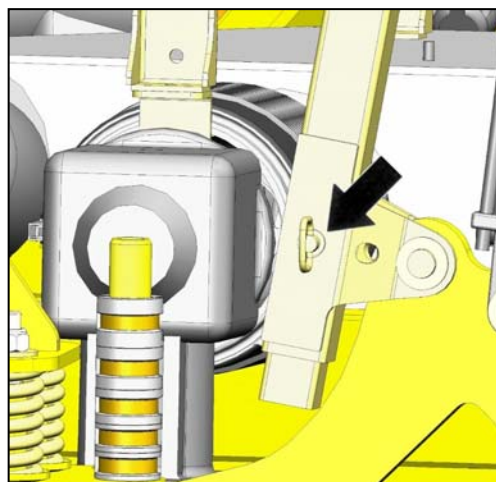

Transport Position – Bar locked

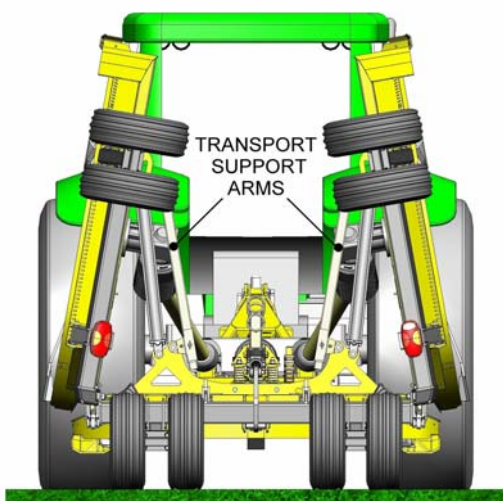

Machine shown in Transportation Position

WARNING:

Ensure the wings of the mower are locked at all times during transportation.

MOVING INTO WORK POSITION

Moving the machine from transport to work position is a direct reversal of the above procedure.

WARNING: Before lowering the wings remember to first release and reposition the wing axles into the work position prior to removing the locking pins from the transport support bars, these pins can then be stowed in the alternative holes in the bars – see *diagram opposite.*

Before lowering the wings ensure sufficient space is available around the machine in which to unfold it - *keep onlookers at a safe distance from the machine during this procedure.*

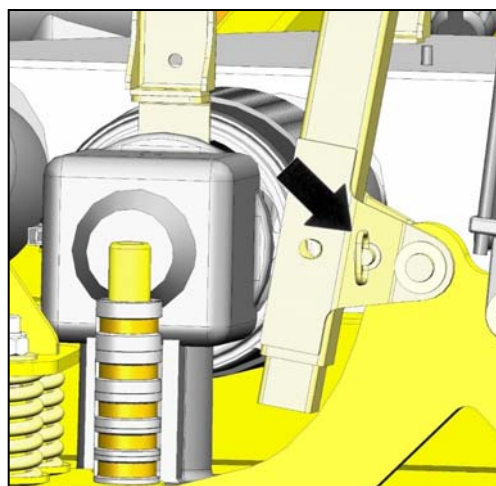

Work Position – Bar unlocked

IMPORTANT TRANSPORTATION INFORMATION

WARNING: “Agricultural Vehicles on the Road” (See *Table below*)

Vehicle Width	Conditions of Use
2.55 to 3 metres	Speed Limit 20mph ** (see caution below)
3 to 3.5 metres	As above plus 24 hour conditional notification to the Police*

Explanation of requirements in table above.

**24 hour conditional notification to police - If any part of the journey will be on a road with a speed limit of 40mph or less, or the journey will exceed five miles then 24 hours notice to police is required for each police area the journey will pass through.*

Should you have any queries you are advised to contact the “Abnormal Loads Officer” at your local police authority.

WARNING: This machine can overturn. Use caution when operating in transport position. Limit speed and avoid sharp turns and rough terrain. Be especially careful on rutted roads where the inner rear wheels can ride on the raised ground between the ruts.

WARNING: Keep everyone clear while lifting or lowering mower or raising and lowering wings.



CAUTION: Do not exceed 18 mph (30Km/h) with pneumatic tyres (See *maintenance section*).

WARNING: Use the tractor warning lights, reflectors and other devices for adequate warning to the operators of other vehicles. Comply with local government regulations.

MAINTENANCE

Before operating your rotary mower, ensure it is properly lubricated and thoroughly inspected. The minimum of time and effort is required to regularly lubricate and maintain this machine to provide long life and trouble free operation.

WARNING:

Always stop the tractor's engine, remove the key and disengage the PTO before attempting any form of maintenance or lubrication work on this machine. If guarding is removed during maintenance always ensure it is replaced before operating the machine – if guards are damaged or missing the machine should not be used until they have been repaired or replaced and refitted correctly.

GENERAL LUBRICATION

Do not allow excess grease to collect on or around the machines components – this is particularly important when operating in sandy areas. Refer to the accompanying illustrations on the following page which show the lubrication points and frequency for normal use – severe or unusual working conditions may require more frequent lubrication.

Use SAE multi-purpose, lithium-type grease for all 'greasing point' locations shown - clean fittings thoroughly before using grease gun. Daily lubrication of the wing driveshaft slip joint is necessary - failure to maintain proper lubrication will result in damage to U-joints, gearboxes and/or driveshafts.

GEARBOX LUBRICATION

For divider, centre and wing gearboxes the required lubricant type is SAE 90 or SAE EP80W90T with EP additives for extreme pressure and temperature with an API-GI-5 service rating. Recommended lubricants are: Spartan EP220, Mobil HD 80W90 or a suitable equivalent.

CAUTION: Never overfill the gearboxes - excess pressure during work can cause seals to blow or leak.

Gearbox lubricant levels should be checked on a daily basis – if the gearbox is of a type with a level plug fitted the plug should be removed and the level checked, if correct the oil should be inline with the plug hole – top up only if required to a point where the lubricant starts to run out of the plug hole - replace the level plug. Gearboxes should be filled with SAE90 or semi-fluid grease – where the latter is used, levels should be checked with the gearbox warm.

NOTE: *If the wings have been in the vertical position immediately prior to a lubricant level inspection, allow sufficient time for the gearboxes semi-fluid lubricant to settle to its true level before inspecting.*

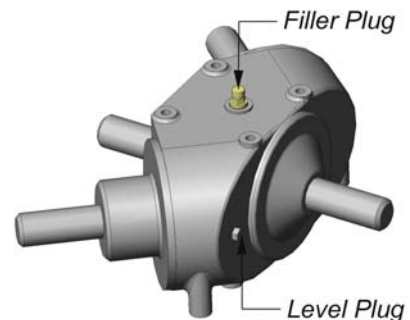

Divider Gearbox

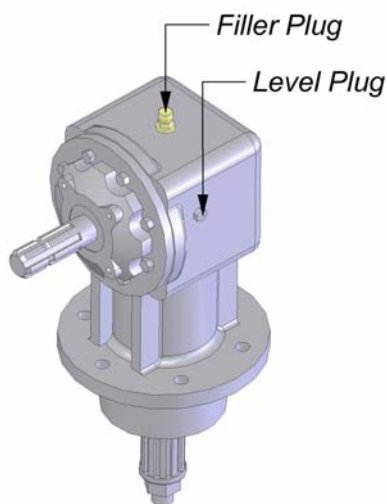

Centre & Wing Gearboxes

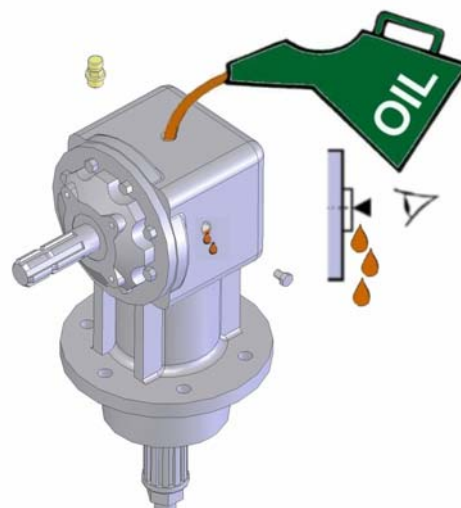

Lubricant 'top up'

LUBRICATION

Greasing Point Locations



Grease locations indicated every 8 working hours
- use SAE multi-purpose lithium type grease.

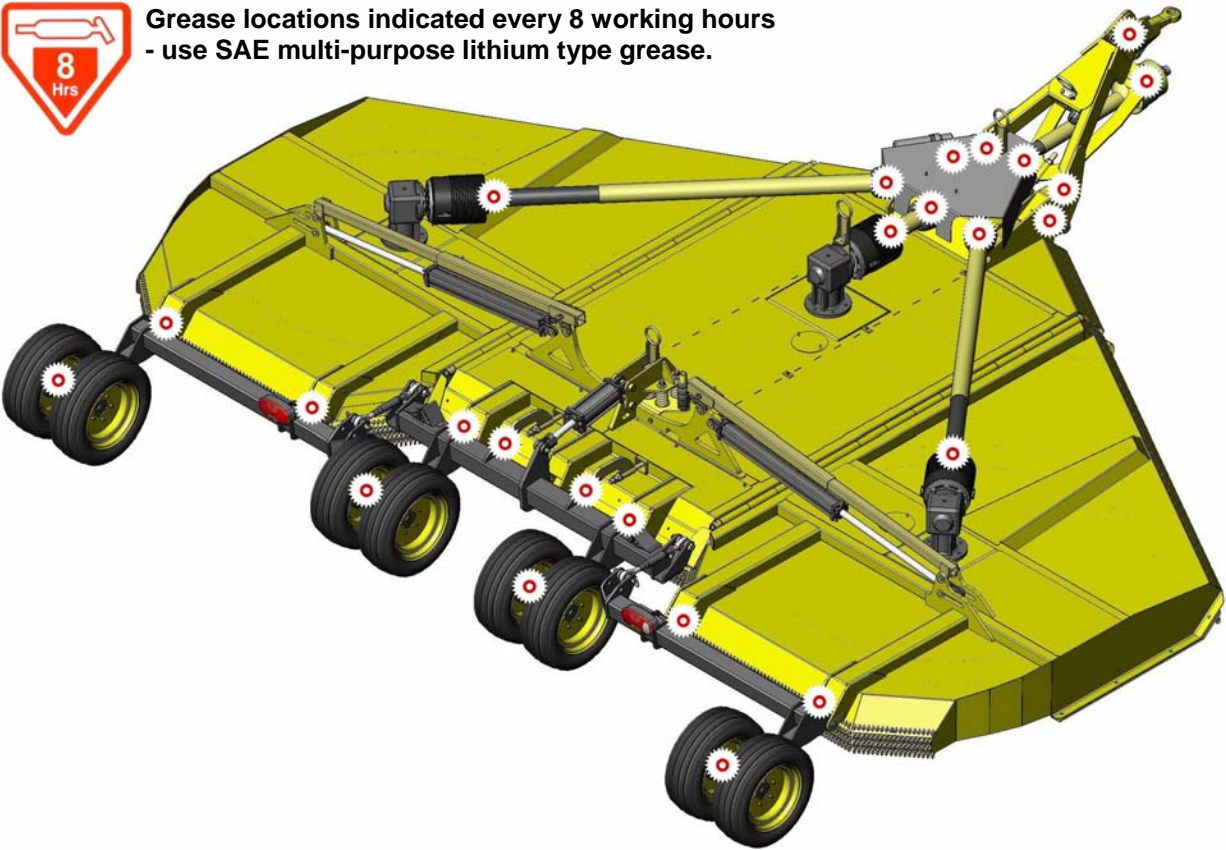

Gearbox Lubricant Checkpoints

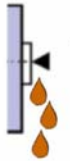

Check gearbox lubrication levels daily at the locations indicated
- top up only if required using recommended lubricant.

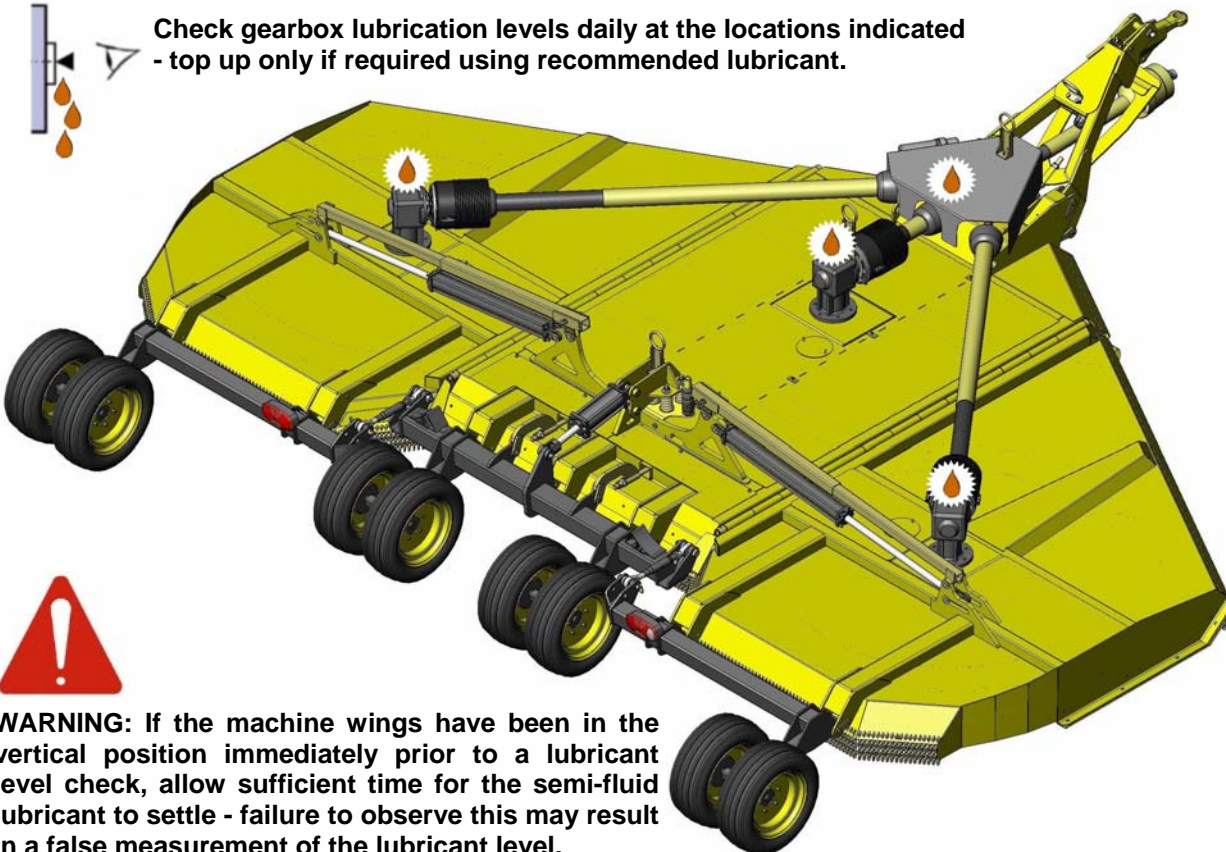

WARNING: If the machine wings have been in the vertical position immediately prior to a lubricant level check, allow sufficient time for the semi-fluid lubricant to settle - failure to observe this may result in a false measurement of the lubricant level.

DRIVELINES

The driveshafts and U-joints should be inspected each time before the mower is started. The U-joint and CV joint on the driveline undergo extreme forces when the unit is turning or when the wings are being raised and lowered. It is important that the U-joints and CV joint are greased each day prior to use of the machine - U-joints are located at each end of the centre and wing driveshafts and the CV joint is located at the end of the main driveshaft. The U-joint and CV joint assemblies are accessible by rotating the driveline safety shield until the hole in the shield matches up with the grease fitting - use *No. 2 bearing grease for lubrication*. Inspect the U-joint for wear on a regular basis – this is achieved by holding the shaft on one side of the joint whilst trying to rotate the shaft on the other side - if noticeable movement is experienced replace the U-joint before it causes severe damage to the driveline. Ensure driveline guards are regularly lubricated so that they remain stationary when the shaft is turning.

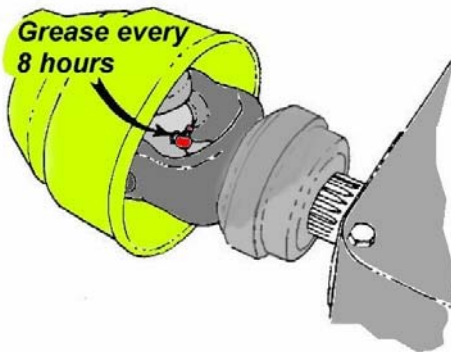

Grease every 8 Hours

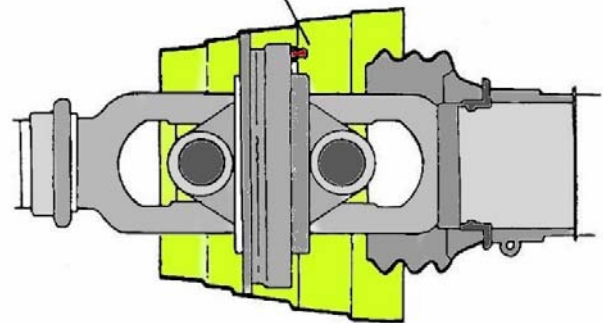

Location of U-joint Grease Point

GUARDING

It is vital on a machine of this type and nature that all safety guards remain in good condition and are fitted correctly; therefore a close visual inspection of all guarding and fixings should be performed on a daily basis prior to use of the machine. Broken or damaged guards and/or fixings must always be replaced before attempting to operate the machine.

DANGER: Never operate the machine with damaged or missing guards.

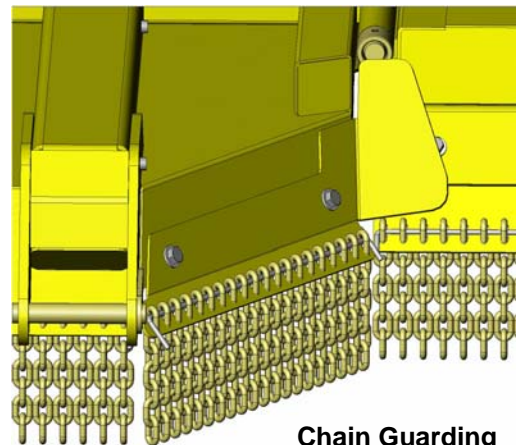

Chain Guarding



Driveshaft Guarding



Divider Gearbox Cover & Driveshaft Guarding

HITCH ATTACHMENT

LUBRICATION

The illustration below shows the greasing points for the machines hitch attachment - these locations should be lubricated after every 8 hours of normal use. The greasing points on the high hitch versions are in the same locations.

INSPECTION

The pins that connect the hitch to the machines centre deck are subjected to extreme forces during operation of the machine; therefore, as a precautionary measure, they should be removed and inspected for signs of wear or damage on a regular basis - replaced the pins at the first signs of a problem.

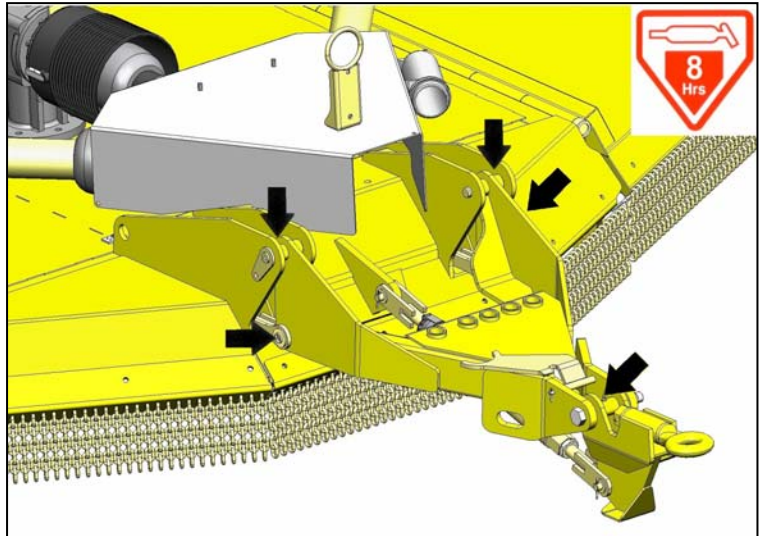

Hitch Attachment Lubrication Points (*Low hitch shown*)

WHEEL ASSEMBLIES

HUB LUBRICATION

The twin wheel hub assemblies are fitted with grease points at each end – access is gained on the inner sides of the pairs of wheels - See *diagram opposite*. Wheel hubs should be lubricated after every 8 working hours of normal use.

TYRE PRESSURE

The recommended tyre pressure is 30 psi (*2 Bar*).

WHEEL NUTS

Tighten wheel nuts to 96ft.lbs (*130Nm*).

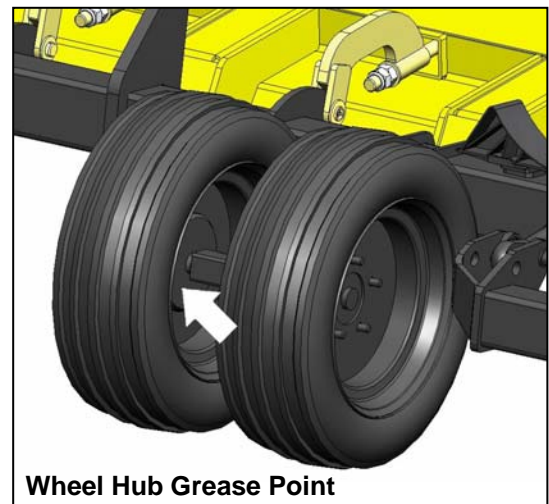

Wheel Hub Grease Point

BLADES & BLADE PANS

WARNING!

All inspection and maintenance work carried out on the blades and blade carriers should only be performed under the following conditions:

- ▲ The unit must be parked on a firm level site.
- ▲ Tractor must be in neutral with the parking brake on and the wheels 'chocked'.
- ▲ Tractor's engine must be switched off and the key removed.
- ▲ PTO shaft must be disengaged.
- ▲ Mower should be raised and safely supported on blocks or stands.

BLADE REMOVAL

Access for removal of the blade bolt locknuts is gained via removal of cover plates located near the gearboxes on the mowers upper decks – once removed the blade bolts and locknuts should be inspected for wear and thread damage.

Blade bolts should be replaced if wear on the pivot edge is in excess of 6mm (1/4") – see diagram below. Inspect the locknuts for thread damage and replace if required – always replace the locknuts when fitting new blade bolts

If an existing blade bolt is re-used it should be installed with its partially worn side furthest away from the centre of the blade pan. **Tighten blade bolt locknuts to 300ft.lbs (407Nm).**

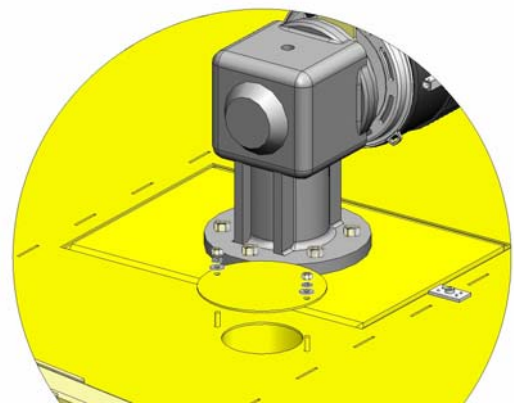

Access to Blade Bolt Locknuts

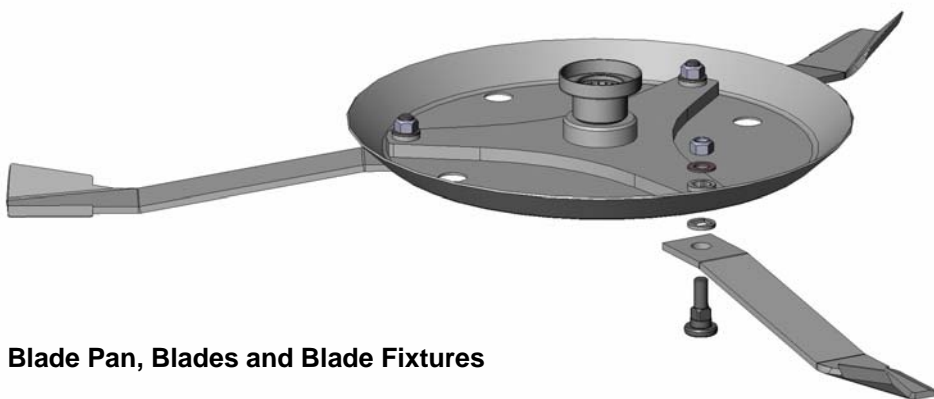

Blade Pan, Blades and Blade Fixtures

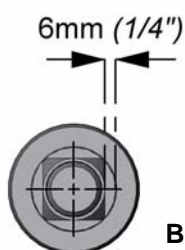
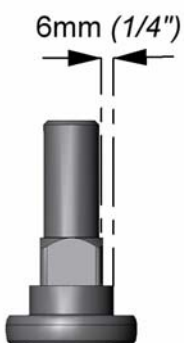
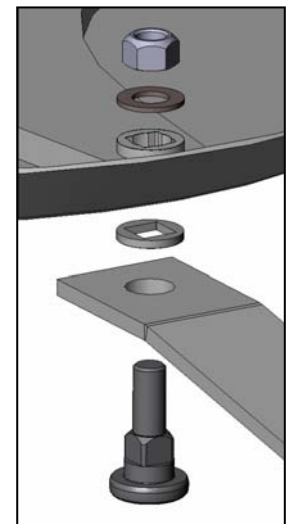

Blade Bolt – Maximum Wear Limit 6mm (1/4")

BLADE SERVICING

Inspect blades before each use to determine that they are properly installed and in good condition. Replace any blade that is bent, excessively nicked, worn or has any other damage. Small nicks can be ground out when sharpening.

WARNING! Use only original equipment blades on this mower - they are made of special heat-treated alloy steel. Substitute blades may not meet specification and thus may be dangerous.

BLADE SHARPENING

Always sharpen all the blades on each cutting unit at same time in order to maintain balance. Follow the original sharpening pattern as illustrated in the diagram below. Always sharpen blades by grinding. **DO NOT** heat and pound out edge. Do not sharpen blade to a razor edge, but leave a 2mm ($1/16$ ") blunt edge. Do not sharpen the back side of blade.

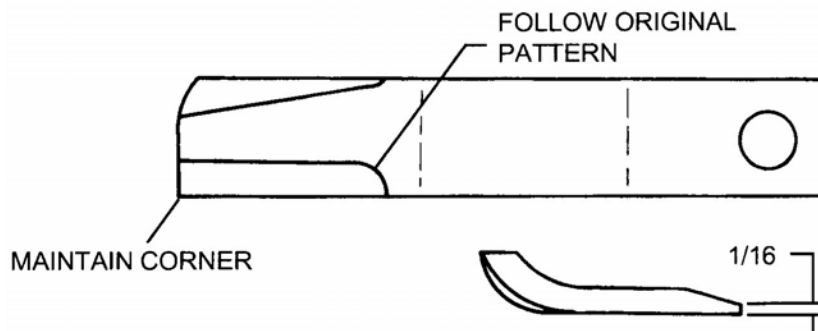

IMPORTANT: When sharpening blades, grind each blade by the same amount to maintain balance. The difference in blade weights should not exceed 25g (*1 ounce*). Unbalanced blades will cause excessive vibration, which can damage gearbox bearings. Vibration may also cause structural cracks in cutter housing.

WARNING: Never work under equipment supported by a hydraulic device because it may drop if the control is actuated (even with the engine stopped) or in the event of hose failure etc. Always use a secure support when servicing equipment in the raised position.

BLADE PAN REMOVAL

Remove cotter pin and loosen the slotted nut on gearbox shaft – do not remove the nut until the blade pan has been loosened. Use a suitable two-jaw gear-puller to draw the carrier off the tapered gearbox shaft. If a gear puller is not available use a long bar inserted through blade bolt access hole with its end against rotor bar - strike opposite end of bar with a sledge hammer and then rotate the blade carrier through 180° and repeat the process. Once the carrier is loose on the shaft the slotted nut, washer and blade carrier can be removed fully.

BLADE CARRIER INSTALLATION

Clean the splines on both the blade carrier and gearbox output shaft. Position carrier on the output shaft and install flat washer and 25mm (*1"*) slotted nut. Tighten nut holding blade carrier to minimum 450ft.lbs. ($610Nm$), strike the carrier onto the hub several times with a heavy hammer to seat the hub. Use a suitable spacer over the nut to prevent damage to the nuts and threads. Re-tighten the nut to 450 ft lbs. ($610Nm$). Install and spread the locking cotter pin.

NOTE: After a few hours of operation always re-check blade carrier retaining nut torque.

WARNING: Do not work under the machine without suitable support to prevent the frame from falling.

BLADE CUTTING DIRECTION

The diagram below shows the cutting direction of each of the mowers three cutting units – the centre deck and right hand wing units cut in an anti-clockwise direction and the left hand wing unit cuts in a clockwise direction when viewed from above.

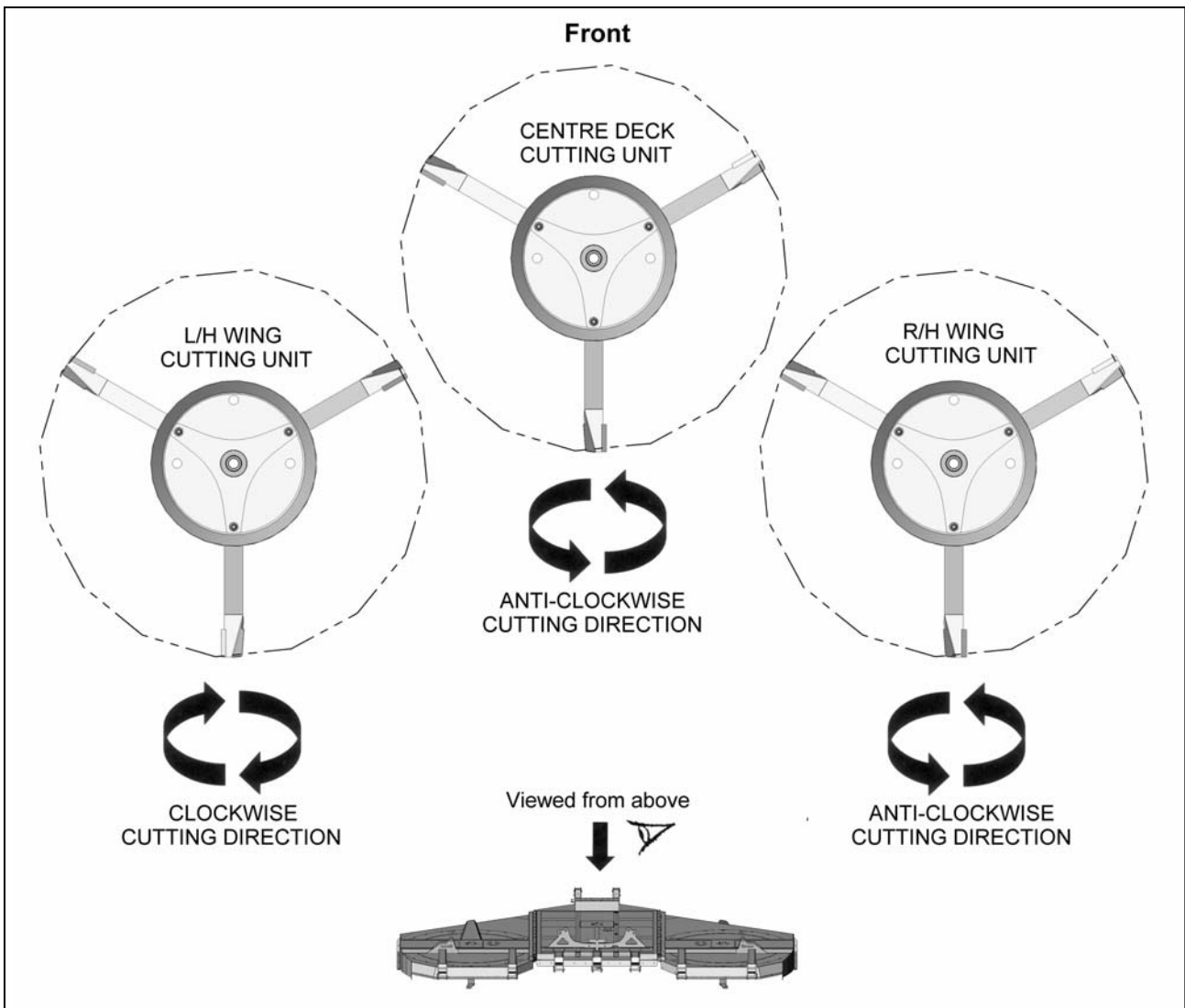

SLIP CLUTCHES

Slip clutches are incorporated into the 3 drivelines that link the divider gearbox to the blade driving gearboxes; the clutches are designed to slip so as to absorb 'shock loads' thus protecting drive and driveline components. Ideally the clutches will slip on start-up, to clean the mating surfaces before gripping to provide sufficient cutting power.

Machines are supplied initially with the slip clutches set to a low torque valve; this is to ensure that they all 'slip' when powered up for the first time. The slip clutches must be reset before putting the machine to work - *refer to settings on following page*.

After the first hour of operation - check clutches for overheating.

CLUTCH ADJUSTMENT

To adjust the clutch, tighten all the spring nuts equally a maximum of 1/6th turn at a time. Do not adjust below the minimum dimension stated – *refer to Spring Settings*.

Check friction lining plates on a weekly basis for oil, grease, wear and moisture that can cause corrosion on the drive plates.

When new, the lining plates are 3mm (1/8") thick - the plates should be replaced after 0.75mm (1/32") of wear – each slip clutch consists of 4 friction lining plates. If the mower has been idle for an extended period of time (over 30 days) or in wet weather, before operation of the machine, the clutches should be checked to ensure that the friction lining plates are not rusted or corroded together – if the clutches are 'frozen' refer to the procedure for freeing them as described in the seasonal clutch maintenance section below.

SEASONAL CLUTCH MAINTENANCE

It is important that the clutches slip when an obstacle or load heavier than the clutch setting is encountered. Therefore, if the machine sits outside longer than 30 days, and is exposed to rain and/or humid air, it is important to make sure that the clutch lining plates are not rusted or corroded together. Before using the machine, adopt the following procedure to ensure the clutches slip correctly and offer the overload protection required.

- Measure spring length – *refer to correct settings in chart on following page*.
- Loosen nuts on springs until the springs can freely rotate, yet remains secure on bolts.
- Mark outer plates as shown in the following diagram.
- Set the engine speed at 1200 rpm.
- Engage the PTO (approximately one second) and then quickly disengage it. The friction lining plates should break loose (check the marks).
- Turn tractor off and inspect marks on plates – if clutches have operated the marks should now be out of alignment - If not, the clutches will need to be completely dismantled in order to free them and all mating surfaces cleaned.
- If test power ok, tighten the nuts on the springs to their original position and replace all guarding.

Slip Clutch - Component Identification & Location

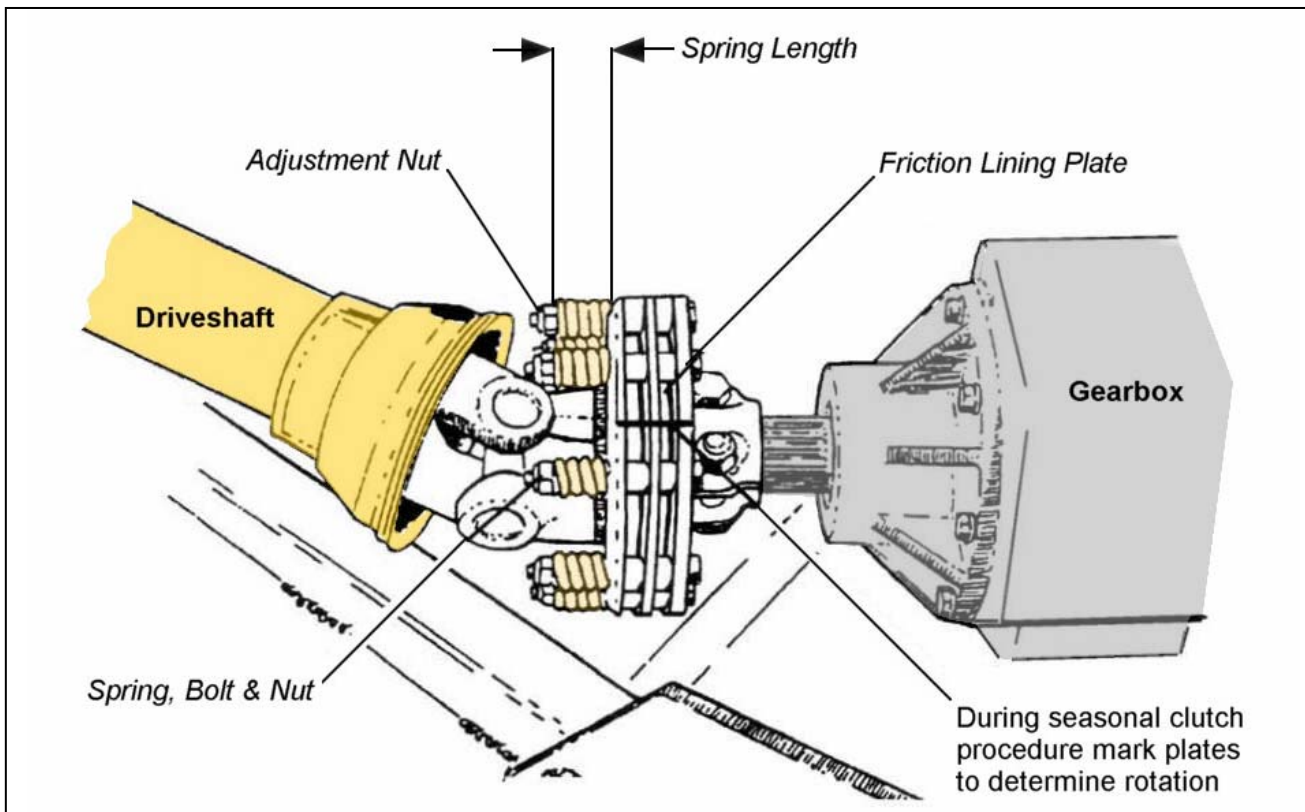

SLIP CLUTCH SPRING SETTINGS

DRIVE SHAFTS		Part Numbers		Spring Length Settings	
Manufacturer	Centre Shaft	Wing Shaft	Centre Shaft	Wing Shaft	
EG Shafts (Comer)	00756634ACE	00756633A	33.0mm	33.0mm	
Walterscheid Shafts	1058259	1058258	39.0mm	39.0mm	

HYDRAULIC HOSES

Replace pinched or damaged hydraulic hoses at immediately. Tighten any hydraulic fitting that shows signs of fluid leakage - *care must be exercised when tightening hydraulic components as over tightening can cause the fittings to fracture which will then necessitate replacement of the damaged component.*

When refitting hoses avoid kinks and sharp bends and ensure that hoses do not 'chafe' on sharp edges. Always allow enough slack in the hose run for free movement.

HYDRAULIC CYLINDERS

Although a small amount of oil will be present from bleeding at all hydraulic fittings, significant amounts of oil leaking around the breather plug on the cylinder indicates that the seals in the cylinder are worn out. Replace the seals in the cylinder immediately before the cylinder is damaged or too much hydraulic fluid is lost.

SKID SHOES

Skid shoes are made of carbon steel to reduce wear and increase service life. Premature wear can be caused by the mower centre or wing sections being set too low which allows the wing skid shoes to drag on the ground. Dragging the skid shoes on the ground or running the skid shoes into solid objects can contribute to early frame failure on the mower. Replace worn skid shoes as required.

CORRECT TORQUE FOR FASTENERS

The chart below lists the correct tightening torque for fasteners. When bolts are to be tightened or replaced, refer to this chart to determine the grade of bolts and the proper torque except when specific torque values are assigned in manual text.

RECOMMENDED TORQUE IN FOOT POUNDS (NEWTON-METERS) UNLESS OTHERWISE STATED IN THE MANUAL

TORQUE VALUES FOR IMPERIAL BOLTS

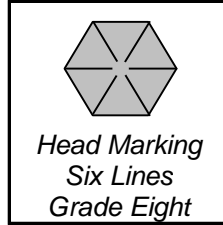
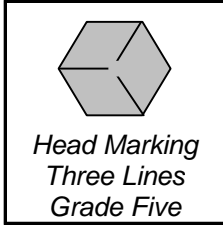
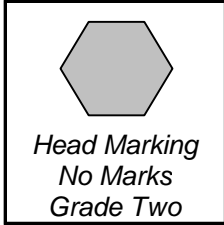
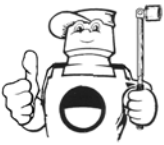

NOTE:
The values in the chart apply to fasteners as received from the supplier, dry or when lubricated with normal engine oil. They DO NOT apply if special graphited, molydisulphide greases, or other extreme pressure lubricants are used. This applies to both UNF and UNC coarse threads.

Bolt Dia.
1/4"
5/16"
3/8"
7/16"
1/2"
9/16"
5/8"
3/4"
7/8"
1"
1-1/8"
1-1/4"
1-3/8"
1-1/2"

Value (Dry)	
ft.lb.	Nm.
5.5	7.5
11	15.0
20	27.0
32	43.0
50	68.0
70	95.0
100	135.0
175	240.0
175	240.0
270	360.0
375	510.0
530	720.0
700	950.0
930	1250.0

Value (Dry)	
ft.lb.	Nm.
9	12.2
18	25.0
33	45.0
52	70.0
80	110.0
115	155.0
160	220.0
280	380.0
450	610.0
675	915.0
850	115.0
1200	1626.0
1550	2100.0
2100	2850.0

Value (Dry)	
ft.lb.	Nm.
12.5	17.0
26	35.2
46	63.0
75	100.0
115	155.0
160	220.0
225	305.0
400	540.0
650	880.0
975	1325.0
1350	1830.0
1950	2650.0
2550	3460.0
3350	4550.0

TORQUE VALUES FOR METRIC BOLTS.

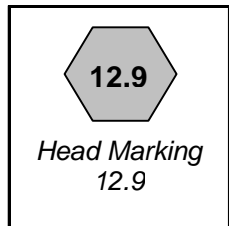
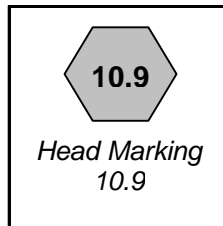
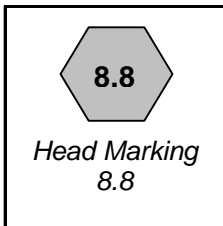
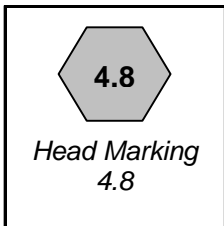

Bolt Dia.
6mm
8mm
10mm
12mm
14mm
16mm
18mm
20mm
22mm
24mm
27mm
30mm

Value (Dry)	
ft.lb.	Nm.
4.5	6.1
11	14.9
21	28.5
37	50.2
60	81.4
92	125.0
125	170.0
180	245.0
250	340.0
310	420.0
450	610.0
625	850.0

Value (Dry)	
ft.lb.	Nm.
8.5	11.5
20	27.1
40	54.2
70	95.0
110	150.0
175	240.0
250	340.0
350	475.0
475	645.0
600	810.0
875	1180.0
1200	1626.0

Value (Dry)	
ft.lb.	Nm.
12	16.3
30	40.1
60	81.4
105	140.0
165	225.0
255	350.0
350	475.0
500	675.0
675	915.0
850	1150.0
1250	1700.0
1700	2300.0

Value (Dry)	
ft.lb.	Nm.
14.5	20.0
35	47.5
70	95.0
120	160.0
190	260.0
300	400.0
410	550.0
580	790.0
800	1090.0
1000	1350.0
1500	2000.0
2000	2700.0

HUB ASSEMBLY

When attempting taper roller bearing adjustment it should be noted that there is not a specified torque setting for the shaft crown nut since there should always be axial play (end float) with a taper roller bearing set up

On the hub – stub axle set up the bearings are held axially by a wide base crown nut.

With the double drilling of retention clip holes in the threaded shaft end a +45° to -45° adjustment is possible in order to give maximum axial play (end float) on the bearings of 0.18mm.

WHEEL NUTS

Wheel nuts should be tightened to 96ft.lbs (130Nm).

BEARING ADJUSTMENT

- 1 Ensure that the spindle is clean and that the front bearing can slide on the front spindle. Fit back-up spacer (washer)
- 2 Fit the rear grease seal, rear bearing, hub and front bearing to the spindle (ensure front and rear taper roller bearings are packed with grease) and screw on the crown nut.
- 3 Using the appropriate spanner - *a torque wrench is not required* - tighten the crown nut while turning the hub clockwise until the bearing friction begins to drag - *the hub becomes difficult to turn, do not tighten to the point where the hub will not turn at all.*
- 4 Turn back the crown nut (anti clockwise) until the hole in the spindle and slot in the crown nut line up, (if the hole and the slot line up at the point of tightening as in the previous paragraph it is essential that the crown nut is turned anti-clockwise until the hole and slot again line up.)
- 5 Insert the retention pin and hook the bow spring into the appropriate groove in the crown nut.
- 6 Check the adjustment by turning the hub clockwise. The hub should turn freely the only friction should be the rear grease seal.
- 7 Partially fill the metal hubcap with grease and knock into position into the end of the hub.
- 8 Recheck the bearing set up and hub grease content after 40 hours operation.



McConnel Limited, Temeside Works, Ludlow, Shropshire SY8 1JL. England.
Telephone: 01584 873131. Facsimile: 01584 876463. www.mcconnel.com