

Publication 728
February 2013
Part No. 22675.28
Revision: 04.07.16



McCONEl

SNOW BLOWER

ROBOCUT ACCESSORY (4000952)

Pre-2022 Builds

Operation Manual



IMPORTANT

VERIFICATION OF WARRANTY REGISTRATION



Dealer Warranty Information & Registration Verification

It is imperative that the selling dealer registers this machine with McConnel Limited before delivery to the end user – failure to do so may affect the validity of the machine warranty.

To register machines; log onto <https://my.mcconnel.com> and select 'Machine Registration' which can be found in the 'Warranty' section of the site. **Confirm to the customer that the machine has been registered by completing the verification form below.**

Registration Verification	Serial No. <input type="text"/>
Dealer Name:	
Dealer Address:	
Customer Name:	
Date of Warranty Registration:/...../..... Dealer Signature:	

Note to Customer / Owner

Please ensure the section above has been completed and signed by the dealer to verify your machine has been registered with McConnel Limited.

IMPORTANT: During the initial 'bedding in' period of a new machine it is the customer's responsibility to regularly inspect all nuts, bolts and hose connections for tightness and re-tighten if required. New hydraulic connections occasionally weep small amounts of oil as the seals and joints settle in – where this occurs it can be cured by re-tightening the connection – *refer to torque settings chart below*. The tasks stated above should be performed on an hourly basis during the first day of work and at least daily thereafter as part of the machine's general maintenance procedure.

CAUTION: DO NOT OVER TORQUE HYDRAULIC FITTINGS AND HOSES

Torque Settings for Hydraulic Fittings

Hydraulic Hose Ends		
BSP	Setting	Metric
1/4"	18 Nm	19 mm
3/8"	31 Nm	22 mm
1/2"	49 Nm	27 mm
5/8"	60 Nm	30 mm
3/4"	80 Nm	32 mm
1"	125 Nm	41 mm
1.1/4"	190 Nm	50 mm
1.1/2"	250 Nm	55 mm
2"	420 Nm	70 mm

Port Adaptors with Bonded Seals		
BSP	Setting	Metric
1/4"	34 Nm	19 mm
3/8"	47 Nm	22 mm
1/2"	102 Nm	27 mm
5/8"	122 Nm	30 mm
3/4"	149 Nm	32 mm
1"	203 Nm	41 mm
1.1/4"	305 Nm	50 mm
1.1/2"	305 Nm	55 mm
2"	400 Nm	70 mm

WARRANTY POLICY

WARRANTY REGISTRATION

All machines must be registered, by the selling dealer with McConnel Ltd, before delivery to the end user. On receipt of the goods it is the buyer's responsibility to check that the Verification of Warranty Registration in the Operator's Manual has been completed by the selling dealer.

1. LIMITED WARRANTIES

- 1.01. *All mounted machines supplied by McConnel Ltd are warranted to be free from defects in material and workmanship from the date of sale to the original purchaser for a period of 12 months, unless a different period is specified.
All Self Propelled Machines supplied by McConnel Ltd are warranted to be free from defects in material and workmanship from the date of sale to the original purchaser for a period of 12 months or 1500 hours. Engine warranty will be specific to the Manufacturer of that unit.*
- 1.02. *All spare parts supplied by McConnel Ltd and purchased by the end user are warranted to be free from defects in material and workmanship from the date of sale to the original purchaser for a period of 6 months. All parts warranty claims must be supported by a copy of the failed part invoice to the end user. We cannot consider claims for which sales invoices are not available.*
- 1.03. *The warranty offered by McConnel Ltd is limited to the making good by repair or replacement for the purchaser any part or parts found, upon examination at its factory, to be defective under normal use and service due to defects in material or workmanship. Returned parts must be complete and unexamined. Pack the component(s) carefully so that any transit damage is avoided. All ports on hydraulic items should be drained of oil and securely plugged to prevent seepage and foreign body ingress. Certain other components, electrical items for example, may require particular care when packing to avoid damage in transit.*
- 1.04. *This warranty does not extend to any product from which McConnel Ltd's serial number plate has been removed or altered.*
- 1.05. *The warranty policy is valid for machines registered in line with the terms and conditions detailed and on the basis that the machines do not extend a period of 24 months or greater since their original purchase date, that is the original invoice date from McConnel Limited.
Machines that are held in stock for more than 24 months cannot be registered for warranty.*
- 1.06. *This warranty does not apply to any part of the goods, which has been subjected to improper or abnormal use, negligence, alteration, modification, fitment of non-genuine parts, accident damage, or damage resulting from contact with overhead power lines, damage caused by foreign objects (e.g. stones, iron, material other than vegetation), failure due to lack of maintenance, use of incorrect oil or lubricants, contamination of the oil, or which has served its normal life. This warranty does not apply to any expendable items such as blades, belts, clutch linings, filter elements, flails, flap kits, skids, soil engaging parts, shields, guards, wear pads, pneumatic tyres or tracks.*
- 1.07. *Temporary repairs and consequential loss - i.e. oil, downtime and associated parts are specifically excluded from the warranty.*
- 1.08. *Warranty on hoses is limited to 12 months and does not include hoses which have suffered external damage. Only complete hoses may be returned under warranty, any which have been cut or repaired will be rejected.*
- 1.09. *Machines must be repaired immediately a problem arises. Continued use of the machine after a problem has occurred can result in further component failures, for which McConnel Ltd cannot be held liable, and may have safety implications.*
- 1.10. *If in exceptional circumstances a non McConnel Ltd part is used to effect a repair, warranty reimbursement will be at no more than McConnel Ltd's standard dealer cost for the genuine part.*

- 1.11. *Except as provided herein, no employee, agent, dealer or other person is authorised to give any warranties of any nature on behalf of McConnell Ltd.*
- 1.12. *For machine warranty periods in excess of 12 months the following additional exclusions shall apply:*
 - 1.12.1. *Hoses, exposed pipes and hydraulic tank breathers.*
 - 1.12.2. *Filters.*
 - 1.12.3. *Rubber mountings.*
 - 1.12.4. *External electric wiring.*
 - 1.12.5. *Bearings and seals*
 - 1.12.6. *External Cables, Linkages*
 - 1.12.7. *Loose/Corroded Connections, Light Units, LED's*
 - 1.12.8. *Comfort items such as Operator Seat, Ventilation, Audio Equipment*
- 1.13. *All service work, particularly filter changes, must be carried out in accordance with the manufacturer's service schedule. Failure to comply will invalidate the warranty. In the event of a claim, proof of the service work being carried out may be required.*
- 1.14. *Repeat or additional repairs resulting from incorrect diagnosis or poor quality previous repair work are excluded from warranty.*

NB Warranty cover will be invalid if any non-genuine parts have been fitted or used. Use of non-genuine parts may seriously affect the machine's performance and safety. McConnell Ltd cannot be held responsible for any failures or safety implications that arise due to the use of non-genuine parts.

2. REMEDIES AND PROCEDURES

- 2.01. *The warranty is not effective unless the Selling Dealer registers the machine, via the McConnell web site and confirms the registration to the purchaser by completing the confirmation form in the operator's manual.*
- 2.02. *Any fault must be reported to an authorised McConnell Ltd dealer as soon as it occurs. Continued use of a machine, after a fault has occurred, can result in further component failure for which McConnell Ltd cannot be held liable.*
- 2.03. *Repairs should be undertaken within two days of the failure. Claims submitted for repairs undertaken more than 2 weeks after a failure has occurred, or 2 days after the parts were supplied will be rejected, unless the delay has been authorised by McConnell Ltd. Please note that failure by the customer to release the machine for repair will not be accepted as a reason for delay in repair or submitting warranty claims.*
- 2.04. *All claims must be submitted, by an authorised McConnell Ltd Service Dealer, within 30 days of the date of repair.*
- 2.05. *Following examination of the claim and parts, McConnell Ltd will pay, at their discretion, for any valid claim the invoiced cost of any parts supplied by McConnell Ltd and appropriate labour and mileage allowances if applicable.*
- 2.06. *The submission of a claim is not a guarantee of payment.*
- 2.07. *Any decision reached by McConnell Ltd. is final.*

3. LIMITATION OF LIABILITY

- 3.01. *McConnell Ltd disclaims any express (except as set forth herein) and implied warranties with respect to the goods including, but not limited to, merchantability and fitness for a particular purpose.*
- 3.02. *McConnell Ltd makes no warranty as to the design, capability, capacity or suitability for use of the goods.*
- 3.03. *Except as provided herein, McConnell Ltd shall have no liability or responsibility to the purchaser or any other person or entity with respect to any liability, loss, or damage caused or alleged to be caused directly or indirectly by the goods including, but not limited to, any indirect, special, consequential, or incidental damages resulting from the use or operation of the goods or any breach of this warranty. Notwithstanding the above limitations and warranties, the manufacturer's liability hereunder for damages incurred by the purchaser or others shall not exceed the price of the goods.*
- 3.04. *No action arising out of any claimed breach of this warranty or transactions under this warranty may be brought more than one (1) year after the cause of the action has occurred.*

4. MISCELLANEOUS

- 4.01. McConnel Ltd may waive compliance with any of the terms of this limited warranty, but no waiver of any terms shall be deemed to be a waiver of any other term.*
- 4.02. If any provision of this limited warranty shall violate any applicable law and is held to be unenforceable, then the invalidity of such provision shall not invalidate any other provisions herein.*
- 4.03. Applicable law may provide rights and benefits to the purchaser in addition to those provided herein.*

McConnel Limited

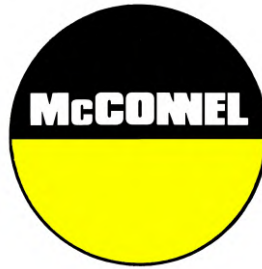

For Safety and Performance...

ALWAYS READ THE BOOK FIRST

McCONEL LIMITED

**Temeside Works
Ludlow
Shropshire
England**

**Telephone: +44 (0)1584 873131
www.mcconel.com**

▲ WARNING

Cancer and Reproductive Harm
www.P65Warnings.ca.gov

D960

Operating, servicing and maintaining this equipment can expose you to chemicals including gasoline, diesel fuel, lubricants, petroleum products, engine exhaust, carbon monoxide, and phthalates, which are known to the State of California to cause cancer and birth defects or other reproductive harm. To minimize exposure, avoid breathing exhaust, do not idle the engine except as necessary, service your vehicle in a well-ventilated area and wear gloves or wash your hands frequently when servicing your vehicle. Battery posts, terminals and related accessories contain lead and lead compounds, chemicals known to the state of California to cause cancer, birth defects or other reproductive harm. For more information go to www.P65Warnings.ca.gov. This website, operated by California's Office of Environmental Health Hazard Assessment, provides information about these chemicals and how individuals may be exposed to them.

CONTENTS

General Information	1
Introduction	2
Machine Identification	3
Handling the Machine	3
Specifications	4
Identification of Components	5
Safety Information	6
Attaching the Machine	7
Operating the Machine	8
Maintenance	10

GENERAL INFORMATION

Always read this manual before attempting to operate the machine – whenever any doubt exists contact your dealer or the McConnel Service Department for advice and assistance.

Use only McConnel Genuine Service Parts on McConnel Equipment and Machines

DEFINITIONS – *The following definitions apply throughout this manual:*

WARNING

An operating procedure, technique etc., which –
can result in personal injury or loss of life if not observed carefully.

CAUTION

An operating procedure, technique etc., which –
can result in damage to either machine or equipment if not observed carefully.

NOTE

An operating procedure, technique etc., which is –
considered essential to emphasis.

LEFT AND RIGHT HAND

These terms are applicable to the machine when it is viewed from the rear facing forwards.

Note: The illustrations in this manual are for instructional purposes only and may on occasion not show some components in their entirety. In some instances an illustration may appear slightly different to that of your particular model but the general procedure will be the same. E&OA.

MACHINE & DEALER INFORMATION

Record the Serial Number of your machine on this page and always quote this number when ordering parts. Whenever information concerning the machine is requested remember also to state the make and model of tractor to which the machine is fitted.

Machine Serial Number:

Installation Date:

Machine Model details:

Dealer Name:

Dealer Address:

Dealer Telephone No:

Dealer Email Address:

INTRODUCTION

The McConnel 'Snow Blower' is an efficient snow clearing machine designed for use as an alternative attachment on McConnel Robocut Mowers. It has been designed as a professional machine for the removal of snow from roads, pathways, parks, ramps and numerous other areas where accessibility is difficult or limited.

This machine must only be used to perform the duties for which it was designed; use of the machine for any other tasks will risk injury to persons and/or damage to the machine.



MACHINE IDENTIFICATION

A machine identification plate is fitted to the machine in the location indicated below.



Always quote the machine type and serial number as stated on the identification plate when ordering replacement parts or requesting assistance.

HANDLING THE MACHINE

Handling the machine should be performed using suitable overhead lifting equipment with a minimum safe lifting capacity over and above the maximum weight of the machine. To ensure even weight distribution when handling the machine it should be lifted using the lift ring; the location of which is indicated below.



WARNING! Ensure bystanders are kept at a safe distance during handling of the machine.

SPECIFICATIONS

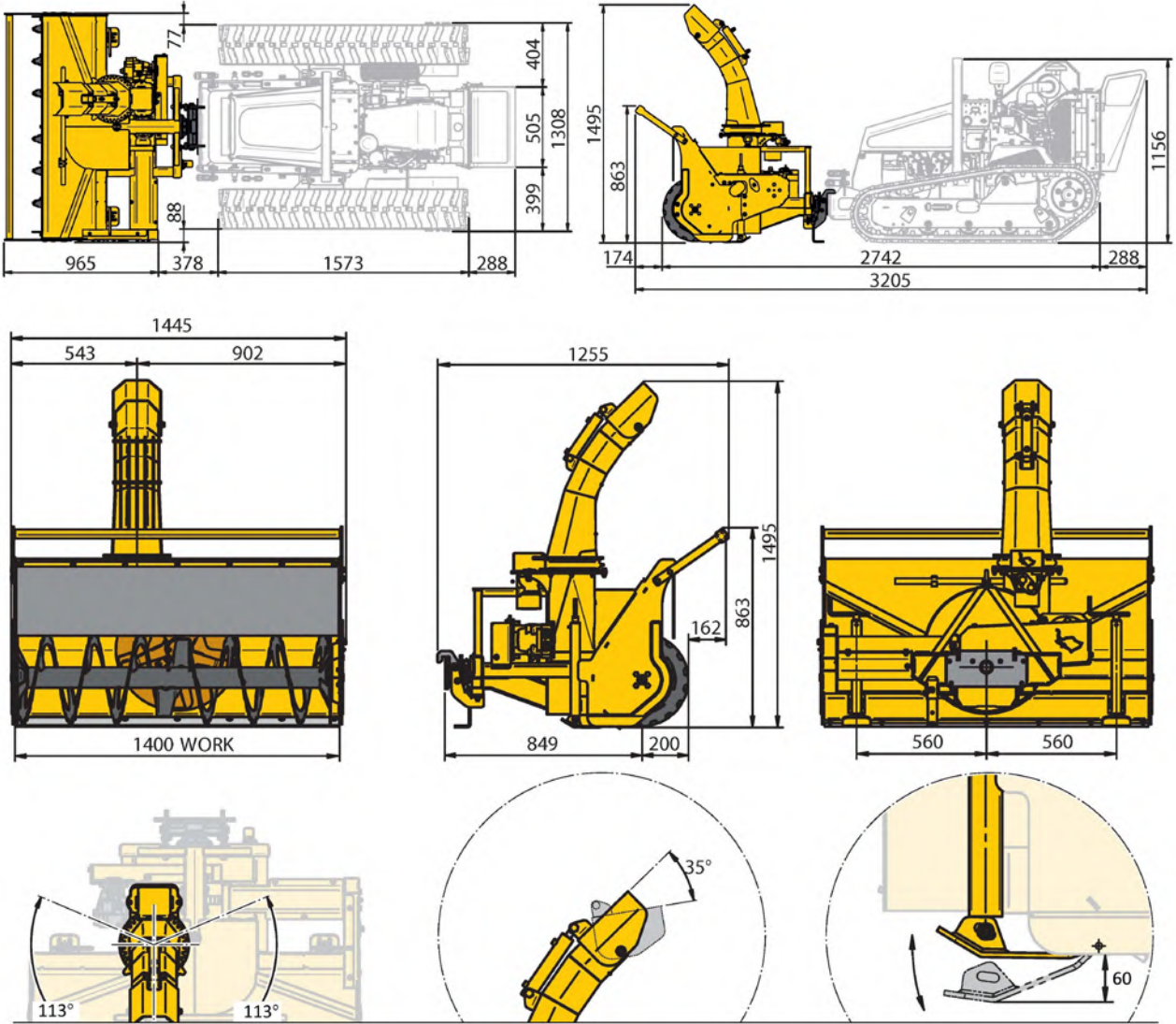

Technical Specifications	
	Cutter Diameter: 400mm (Clockwise rotation)
	Turbine Diameter: 520mm
	Operating Width: 1400mm
	Weight: 290kg
Turbine	Transmission: Hydraulic Max Pressure: 300 bar
Cutter	Transmission: Mechanical (Reduction chain drive) Hydraulic Capacity: 60 l/min Power Demand: Min.30hp – Max.40hp
Chute	Rotation: Hydraulic (Orbital motor) Hydraulic Capacity: 10 – 15 l/min (180 bar)
Chute Baffle	Adjustment: Hydraulic (Ram) Hydraulic Capacity: 10 – 15 l/min (180 bar)
	Working Height Adjustment: Adjustable Skids (Manual)
	Scraper Blade: Wear resistant steel (Replaceable)

IDENTIFICATION OF COMPONENTS

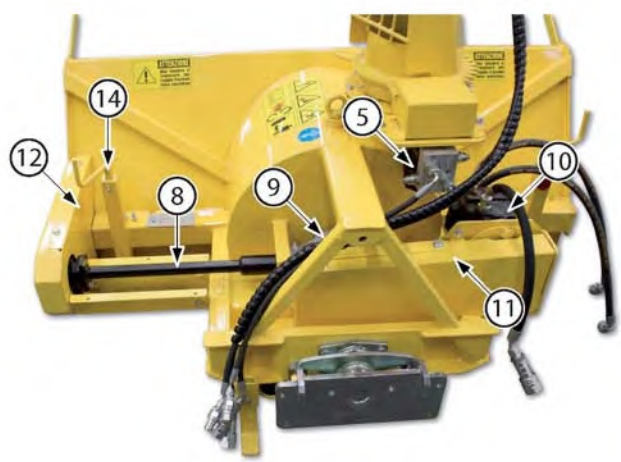
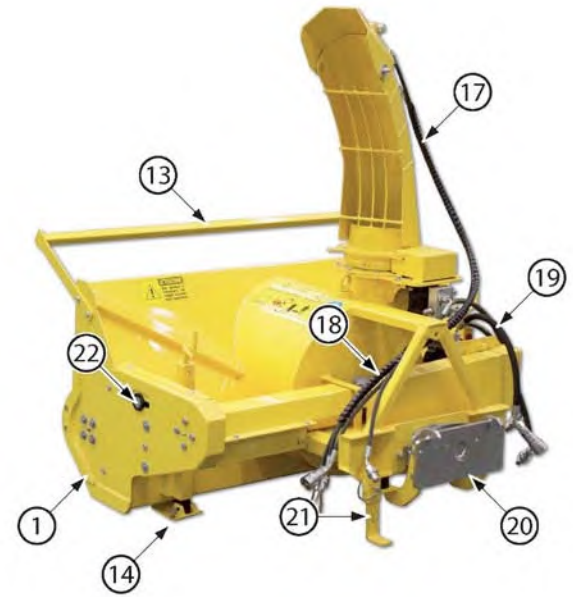

- | | | | |
|----|---------------------------|----|---------------------------------|
| 1 | Frame | 12 | Rotor Drive Chain |
| 2 | Snow Cutter Rotor (Auger) | 13 | Safety Rail |
| 3 | Rotor (Propeller) | 14 | Adjustable Skids |
| 4 | Chute | 15 | Scraper |
| 5 | Chute Rotator | 16 | Casing |
| 6 | Baffle (Deflector) | 17 | Protection Flap |
| 7 | Baffle (Deflector) Ram | 18 | Hydraulic Hoses (Chute Rotator) |
| 8 | Drive Shaft | 19 | Hydraulic Hoses (Rotor Drive) |
| 9 | Gearbox | 20 | Mounting Plate |
| 10 | Hydraulic Motor | 21 | Support Leg (Machine Parking) |
| 11 | Gearbox Drive Chain | 22 | Chain Tensioner |

SAFETY INFORMATION



In addition to the general advice stated below, the main safety implications surrounding the use of this machine relate to the safe use of the Robocut machine; it is therefore vital that all users have read and understood all safety information in the operation manual provided with that machine.

Ensure that all users of this machine are trained in its safe use and have read the operation manual for both this machine and the Robocut Mower.

General Safety

- ▲ Never run or attempt to operate the machine with safety devices missing or removed.
- ▲ Never attempt to approach the machine whilst it is running or working.
- ▲ Never attempt to use the machine for clearing any materials other than snow.
- ▲ Never aim the ejected snow at persons, animals, vehicles or buildings.
- ▲ Never allow persons to ride on the machine.
- ▲ Never allow the snow cutter rotor to touch the ground during operation.
- ▲ Never attempt to introduce materials to, or extract materials from, the machine when the rotor is running with any type of tool, in particular your hands or feet.
- ▲ Never attempt to use a machine with damaged or missing components; repair or replace the parts immediately.
- ▲ Read and abide by all safety message decals displayed on the machine; they are there for your safety and the safety of others.
- ▲ Keep all persons and animal at a safe distance of at least 10m from the working machine.
- ▲ Stop the machine immediately if persons or animals enter into the working zone of the machine, do not restart operations until they are at a safe distance.
- ▲ Before performing any work on the snow blower, including cleaning and maintenance operations, stop the Robocut, wait for the rotor to stop, turn off the engine and remove the security key from the radio control.

ATTACHING THE MACHINE

Attachment and removal of the machine must always be performed on a firm level site. Ensure bystanders are kept at a safe distance from the machines during the attachment process. The procedure for attaching the machine to a Robocut is as follows;

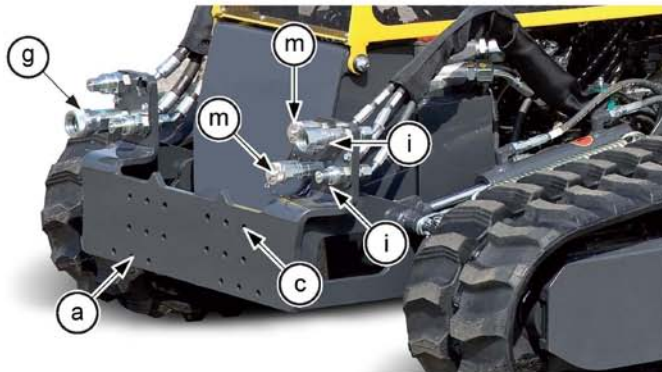

Align the Robocut until its mounting plate **(a)** is centred and parallel to the snow blowers mounting plate **(b)**.

Lower mounting plate **(a)** and move forwards slowly until the two plates are in contact with each other.

Raise the mounting plate **(a)** until the snow blowers mounting plate is fully connected.

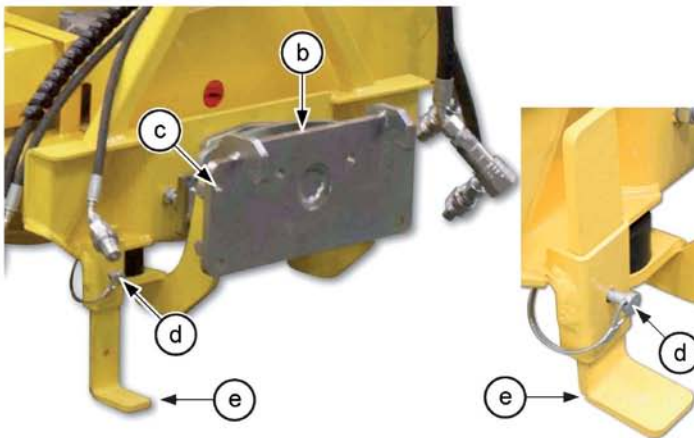

Turn off the Robocut and remove the security key from the controls.

Fix mounting plate **(a)** to mounting plate **(b)** using the 6 screws in the location holes **(c)**; secure in place with self-locking nuts.

Remove lock pin **(d)**, lift the support foot **(e)** then replace the lock pin **(d)**.

Connect the 3 'quick release' hoses from the machines hydraulic motor **(f)** to the Robocut's external connection points.

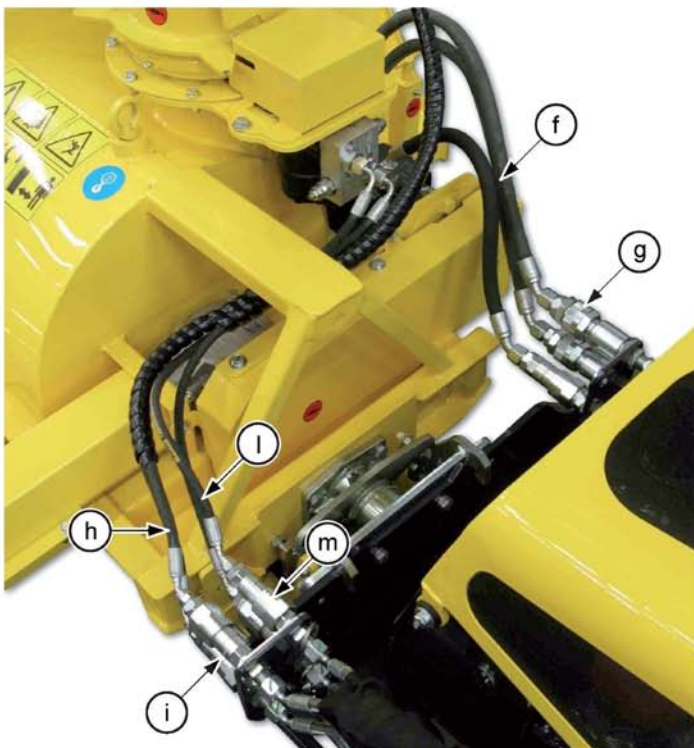

Connect the 2 'quick release' hoses from the chute rotation motor **(h)** to the Robocut's external connection points **(i)**.

Connect the 2 'quick release' hoses from the chute's baffle tilt ram **(l)** to the internal connection points **(m)**.

Ensure that all connections are connected correctly.

Start the Robocut and carefully operate the controls to verify they correspond to their correct functions - in particular make sure that the snow blower's rotor turns clockwise; if this proves not to be the case, turn off the Robocut and swap the hose positions for the pressure and return hoses **(g)**, without disconnecting the drain line.



CAUTION! Carefully clean all hydraulic fittings thoroughly before connecting hoses; this will help avoid the risk of contamination by foreign bodies which can cause pump damage if introduced to the system.

OPERATING THE MACHINE

Operation and control of the Snow Blower features is via the Robocut's Remote Control unit as explained below;

Starting the Rotor

Switching on the machine's propeller rotor and auger is by operation of selector switch 'a', ensure the correct direction is selected; the propeller rotor must turn in a clockwise direction (*viewing the machine from the front*).

Stopping the rotor is by returning the selector switch to the 'OFF' position.



WARNING! When switching off the rotor do not attempt to approach the machine until it has stopped rotating and all moving parts are at a complete standstill.

Rotor Speed

The operating speed of the rotor (RPM) is controlled by operation of the potentiometer switch 'b'; the rotation speed can be increased or decreased as required. The optimum speed for efficient operation will be dictated by particular working conditions, i.e. depth and consistency of snow.

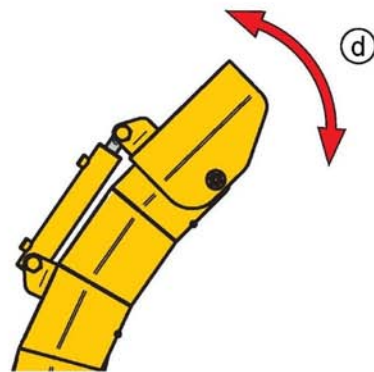
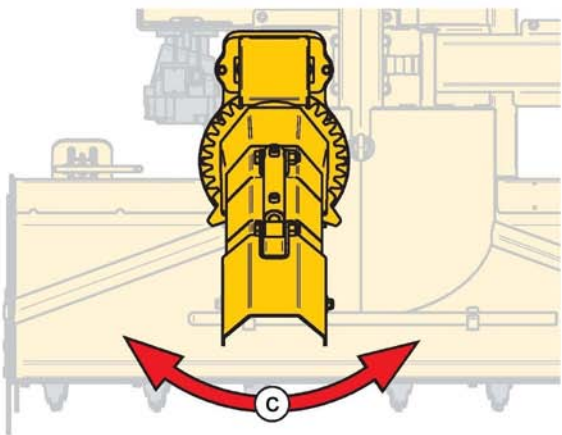
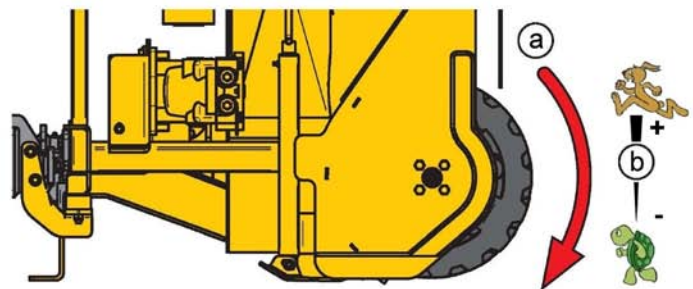

Chute Rotation

The rotational position of the snow chute is controlled by operation of switch 'c'; operate the switch to rotate the chute to the required direction and position for expelling the snow, the chute can be placed to either side of the machine as required.

Baffle (Deflector) Adjustment

The chute baffle (deflector) is controlled by auxiliary switch 'd'; this switch operates the hydraulic ram located on the back of the chute allowing it to open or close the angle of the baffle. This feature, in conjunction with rotor operating speed, will determine the trajectory of the ejected snow.



WARNING! Ensure when operating the machine that snow is expelled in a suitable direction away from any risk of injury to persons or damage to vehicles and buildings.

Skid Adjustment (Minimum Working Height)

The machines feature adjustable skids for pre-setting the minimum work height. The skids are located on the outer edges of the machine and are adjusted via built in screw handles. The minimum height setting is adjustable by up to 60mm.

When adjusting the skids they should be set at approximately the same height to ensure the machine works parallel to the ground.

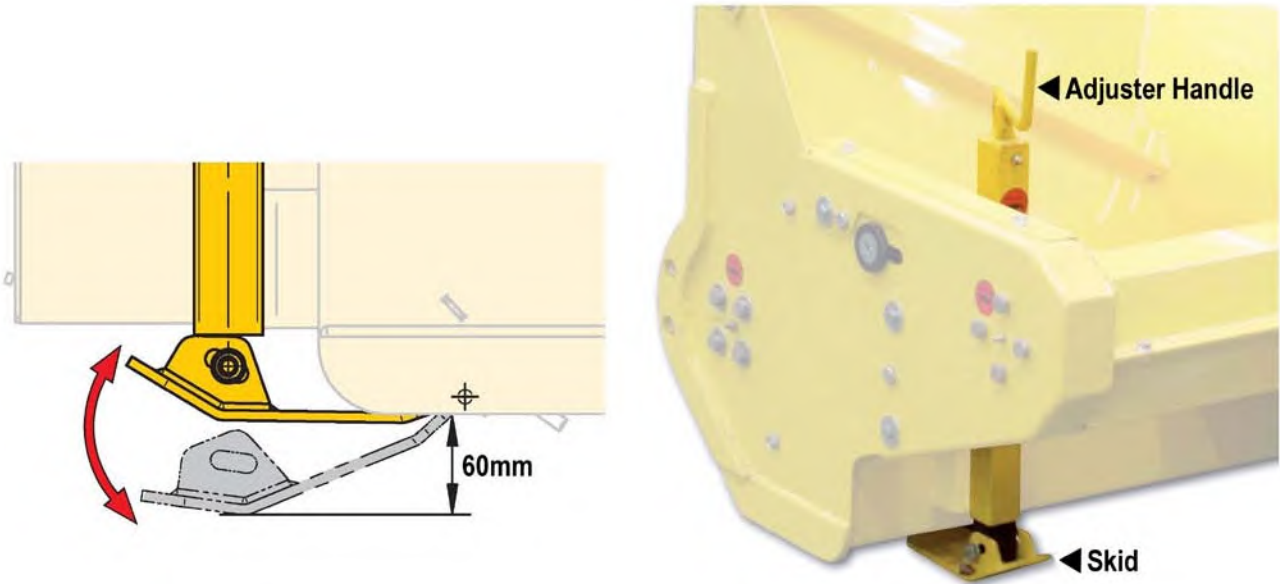

MAINTENANCE

All maintenance, cleaning and repair operations must be performed with the machine firmly lowered to the ground. Should any repairs or maintenance require access from beneath the machine it should be firmly and safely raised and propped using suitable purpose designed supports that are capable of bearing the machines full weight. Care should be adopted at all times when working with or under a raised machine.

Machines should be inspected on a daily basis prior to work to ensure all components are in safe working order.

Check all components for signs of wear or damage and replace or repair if required.

Check nuts and bolts for tightness and retighten if required.

Check all safety guarding is in place and in good working order.

Check hydraulic hoses for signs of wear or leakage; replace or repair if required.

Check hydraulic connections for signs of leakage; tighten or replace if required.

Never operate a machine with damaged or missing components; repair or replace them before attempting to use the machine.

Lubrication

The machines lubrication points are identified below; these should be greased every 50 hours.

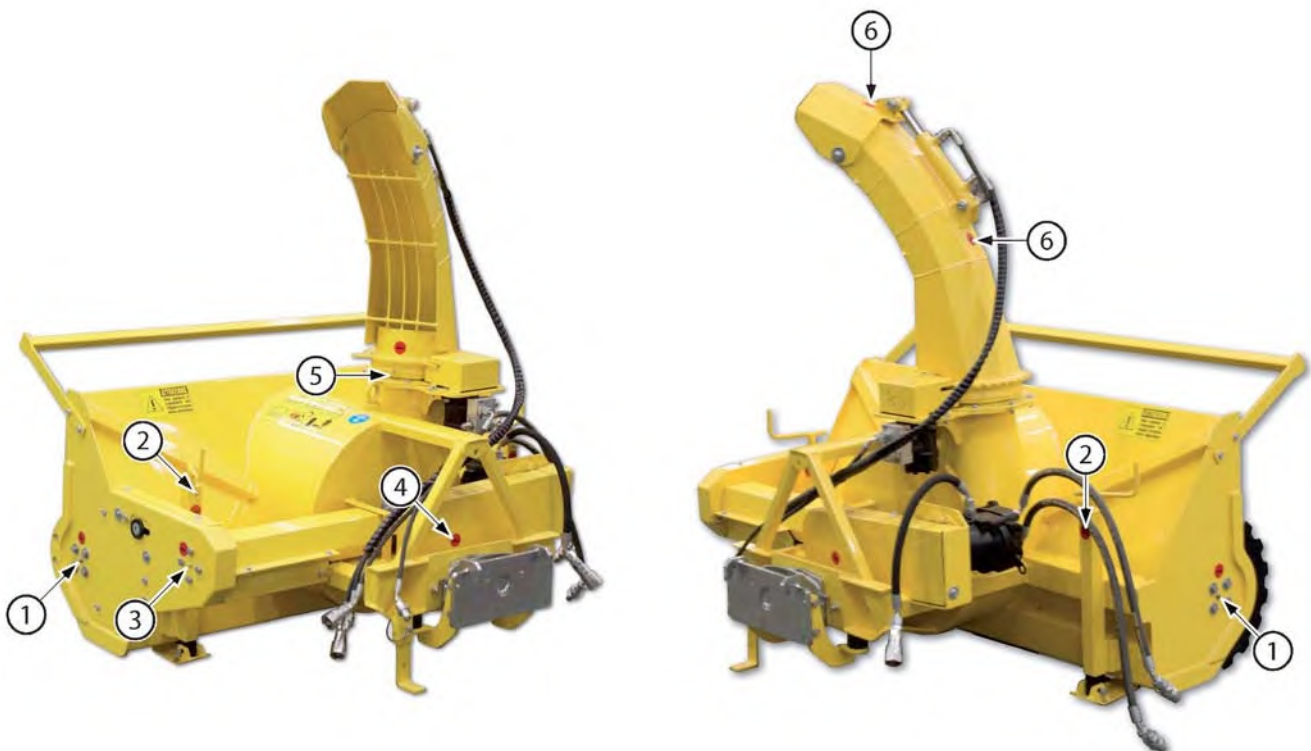

- 1 Rotor (Auger) Bearings
- 2 Slider Pads (Skid Adjusters)
- 3 Drive Shaft

- 4 Hook Up Unit
- 5 Chute Rotator
- 6 Baffle (Deflector) Tilt

Gearbox Drive Chain Adjustment

The procedure for adjusting the gearbox drive chain tension is as follows;

Remove chain guard bolts (a).

Remove chain guarding (b) and (c).

Slacken motor locking nuts (d).

Slacken lock nut (e).

Tighten adjuster screw (f) until the chain is correctly tensioned.

Tighten lock nut (e).

Tighten the locking nuts on the hydraulic motor (d).

Replace chain guarding (c) and (b) and fasten with screws (a).

Run the machine in idle position for a few minutes, then stop the machine and re-check chain tension.

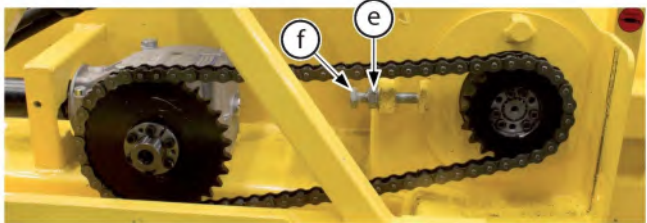
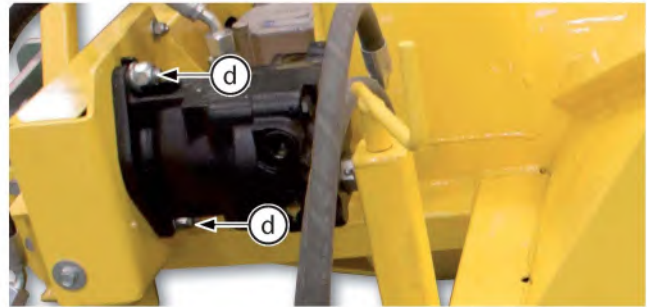
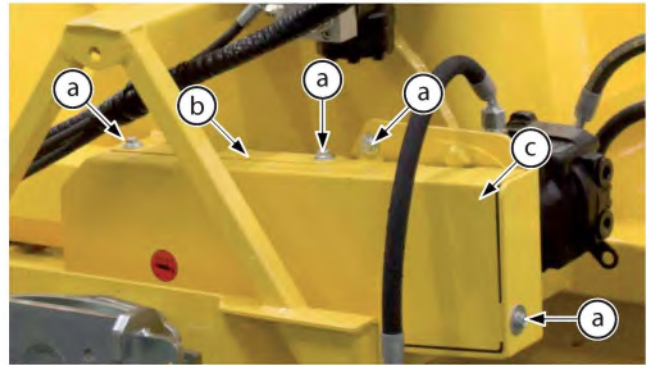

Rotor Drive Chain Adjustment

The procedure for adjusting the rotor drive chain tension is as follows;

Slacken locking screw (a).

Pull chain tensioner pin (b) towards drive shaft until the chain has been tensioned correctly, re-tighten screw (a).

Checking of the chain tension will require removal of chain guard bolts (c) and chain guarding (d). Replace guarding before running the machine.

Run the machine in idle position for a few minutes, then stop the machine and re-check chain tension.

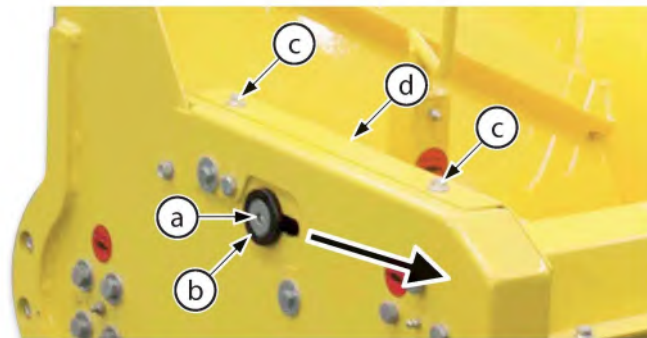

WARNING! Never attempt to run or operate the machine with safety guarding removed or loosely fitted, replace all fixing bolts and tighten correctly.

Shear Bolt Replacement

The machine is equipped with shear bolt protection to prevent damage to drive components if the rotor was to be stopped abruptly by stones or large-sized foreign bodies.

In the event that the bolt shearing, the procedure for replacement is as follows;

Remove the bolts **(a)**.

Remove the drive shaft guarding **(b)**.

Remove the broken shear bolt **(e)**.

Align the bolt hole in flange **(c)** with the bolt hole in flange **(d)**.

Fit a replacement shear bolt **(e)** through the aligned holes in the flanges and tighten.

Replace drive shaft guarding **(b)** and secure in place with bolts **(a)**.

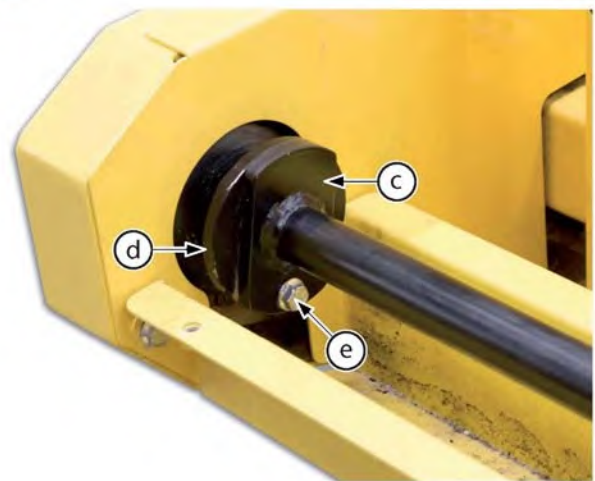
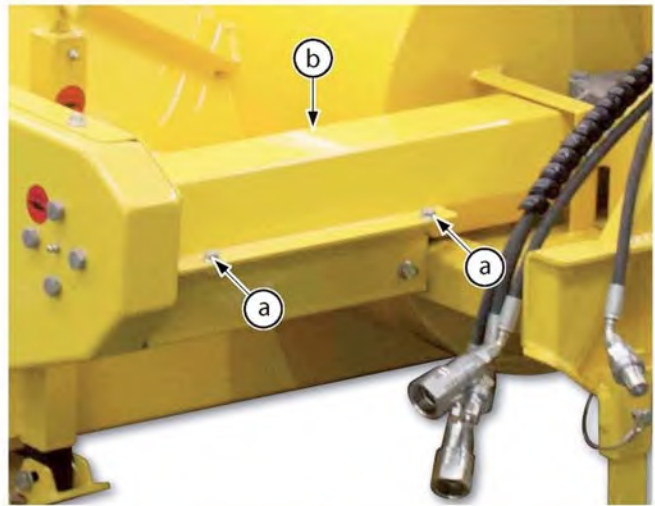

WARNING!



Never attempt to run or operate the machine with safety guarding removed or loosely fitted, replace all fixing bolts and tighten correctly.

Scraper Replacement

Inspect the scraper on a daily basis for signs of wear or damage; it should be replaced immediately if it becomes damaged or when it is worn to the point where it no longer performs its task effectively. The procedure for removal and replacement is as follows;

Remove the clamping screws **(b)**.

Remove the scraper **(a)**.

Fit new scraper.

Replace and tighten screws **(b)**.

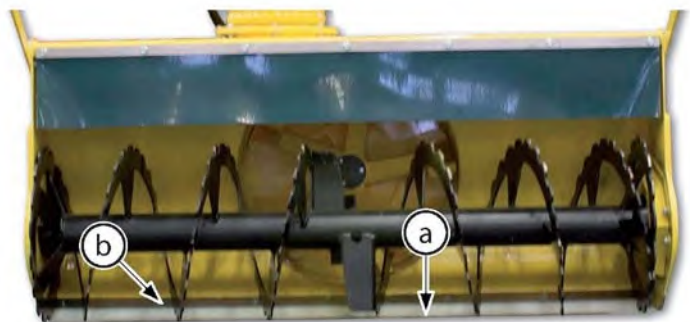

Flexible Guard Replacement

Inspect the flexible guard on a daily basis for signs of wear or damage; it should be replaced immediately if it becomes damaged or when it is worn to the point where it no longer performs its task effectively. The procedure for removal and replacement is as follows;

Remove the clamping screws and nuts **(b)**.

Remove the flexible guard **(a)**.

Fit new guard.

Replace and tighten screws and nut **(b)**.

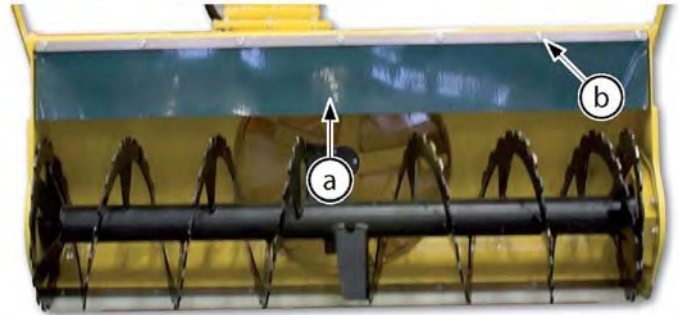

Skids Replacement

Inspect both skids on a daily basis for signs of wear; they should be replaced immediately if they are excessively worn or damaged. The procedure for removal and replacement is as follows;

Remove the clamping bolt **(b)**.

Remove screw that is used as a pin **(c)**.

Remove the skid **(a)** and replace it with a new one.

Refit the clamping bolt **(b)**.

Tighten the screw **(c)**.

Repeat the same operation for both pads.

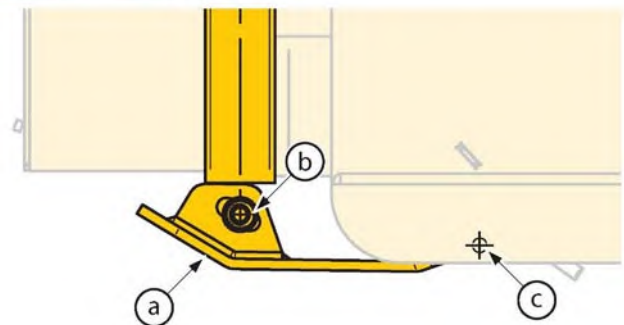
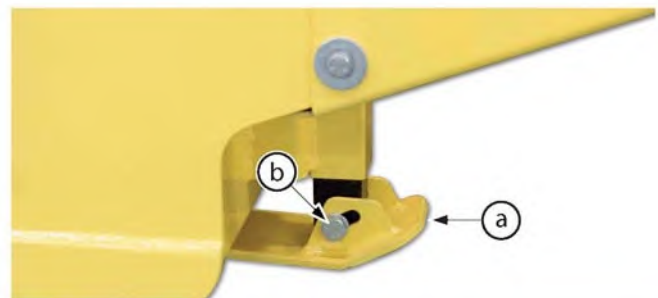

Hydraulic Hoses

Inspect hydraulic hoses and connections on a daily basis for signs of wear or oil leakage; replace any worn or damaged hydraulic components immediately if they are found to be defective in any way.

When inspecting the hoses (a), check that they are not kinked, stretched or being chafed by other components on the machine.

Ensure when replacing hoses that they are routed in the exact same manner as the original hose.

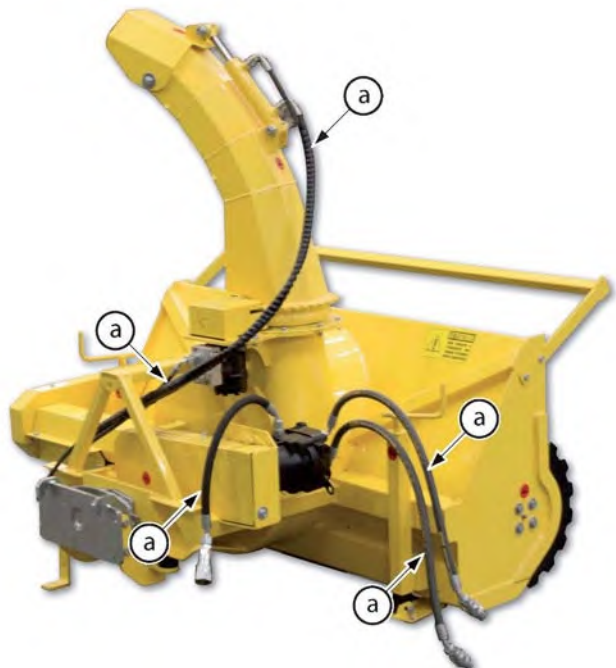



McConnel Limited, Temeside Works, Ludlow, Shropshire SY8 1JL. England.
Telephone: 01584 873131. Facsimile: 01584 876463. www.mcconnel.com