

Publication 1010
November 2021
Part No. 24215.10

SLOPETRAK

400/500 FLAILHEAD

1.3M GRASS / MULCHING FLAILHEAD

TWOSE

Operator Manual



IMPORTANT

VERIFICATION OF WARRANTY REGISTRATION



Dealer Warranty Information & Registration Verification

It is imperative that the selling dealer registers this machine with McConnel Limited before delivery to the end user – failure to do so may affect the validity of the machine warranty.

To register machines; log onto <https://my.mcconnel.com> and select 'Machine Registration' which can be found in the 'Warranty' section of the site. **Confirm to the customer that the machine has been registered by completing the verification form below.**

Registration Verification	Serial No. <input type="text"/>
Dealer Name:	
Dealer Address:	
Customer Name:	
Date of Warranty Registration:/...../..... Dealer Signature:	

Note to Customer / Owner

Please ensure the section above has been completed and signed by the dealer to verify your machine has been registered with McConnel Limited.

IMPORTANT: During the initial 'bedding in' period of a new machine it is the customer's responsibility to regularly inspect all nuts, bolts and hose connections for tightness and re-tighten if required. New hydraulic connections occasionally weep small amounts of oil as the seals and joints settle in – where this occurs it can be cured by re-tightening the connection – *refer to torque settings chart below*. The tasks stated above should be performed on an hourly basis during the first day of work and at least daily thereafter as part of the machine's general maintenance procedure.

CAUTION: DO NOT OVER TORQUE HYDRAULIC FITTINGS AND HOSES

Torque Settings for Hydraulic Fittings

Hydraulic Hose Ends		
BSP	Setting	Metric
1/4"	18 Nm	19 mm
3/8"	31 Nm	22 mm
1/2"	49 Nm	27 mm
5/8"	60 Nm	30 mm
3/4"	80 Nm	32 mm
1"	125 Nm	41 mm
1.1/4"	190 Nm	50 mm
1.1/2"	250 Nm	55 mm
2"	420 Nm	70 mm

Port Adaptors with Bonded Seals		
BSP	Setting	Metric
1/4"	34 Nm	19 mm
3/8"	47 Nm	22 mm
1/2"	102 Nm	27 mm
5/8"	122 Nm	30 mm
3/4"	149 Nm	32 mm
1"	203 Nm	41 mm
1.1/4"	305 Nm	50 mm
1.1/2"	305 Nm	55 mm
2"	400 Nm	70 mm

WARRANTY POLICY

WARRANTY REGISTRATION

All machines must be registered, by the selling dealer with McConnel Ltd, before delivery to the end user. On receipt of the goods it is the buyer's responsibility to check that the Verification of Warranty Registration in the Operator's Manual has been completed by the selling dealer.

1. LIMITED WARRANTIES

- 1.01. *All mounted machines supplied by McConnel Ltd are warranted to be free from defects in material and workmanship from the date of sale to the original purchaser for a period of 12 months, unless a different period is specified.*
All Self Propelled Machines supplied by McConnel Ltd are warranted to be free from defects in material and workmanship from the date of sale to the original purchaser for a period of 12 months or 1500 hours. Engine warranty will be specific to the Manufacturer of that unit.
- 1.02. *All spare parts supplied by McConnel Ltd and purchased by the end user are warranted to be free from defects in material and workmanship from the date of sale to the original purchaser for a period of 6 months. All parts warranty claims must be supported by a copy of the failed part invoice to the end user. We cannot consider claims for which sales invoices are not available.*
- 1.03. *The warranty offered by McConnel Ltd is limited to the making good by repair or replacement for the purchaser any part or parts found, upon examination at its factory, to be defective under normal use and service due to defects in material or workmanship. Returned parts must be complete and unexamined. Pack the component(s) carefully so that any transit damage is avoided. All ports on hydraulic items should be drained of oil and securely plugged to prevent seepage and foreign body ingress. Certain other components, electrical items for example, may require particular care when packing to avoid damage in transit.*
- 1.04. *This warranty does not extend to any product from which McConnel Ltd's serial number plate has been removed or altered.*
- 1.05. *The warranty policy is valid for machines registered in line with the terms and conditions detailed and on the basis that the machines do not extend a period of 24 months or greater since their original purchase date, that is the original invoice date from McConnel Limited.*
Machines that are held in stock for more than 24 months cannot be registered for warranty.
- 1.06. *This warranty does not apply to any part of the goods, which has been subjected to improper or abnormal use, negligence, alteration, modification, fitment of non-genuine parts, accident damage, or damage resulting from contact with overhead power lines, damage caused by foreign objects (e.g. stones, iron, material other than vegetation), failure due to lack of maintenance, use of incorrect oil or lubricants, contamination of the oil, or which has served its normal life. This warranty does not apply to any expendable items such as blades, belts, clutch linings, filter elements, flails, flap kits, skids, soil engaging parts, shields, guards, wear pads, pneumatic tyres or tracks.*
- 1.07. *Temporary repairs and consequential loss - i.e. oil, downtime and associated parts are specifically excluded from the warranty.*
- 1.08. *Warranty on hoses is limited to 12 months and does not include hoses which have suffered external damage. Only complete hoses may be returned under warranty, any which have been cut or repaired will be rejected.*
- 1.09. *Machines must be repaired immediately a problem arises. Continued use of the machine after a problem has occurred can result in further component failures, for which McConnel Ltd cannot be held liable, and may have safety implications.*
- 1.10. *If in exceptional circumstances a non McConnel Ltd part is used to effect a repair, warranty reimbursement will be at no more than McConnel Ltd's standard dealer cost for the genuine part.*

- 1.11. *Except as provided herein, no employee, agent, dealer or other person is authorised to give any warranties of any nature on behalf of McConnell Ltd.*
- 1.12. *For machine warranty periods in excess of 12 months the following additional exclusions shall apply:*
 - 1.12.1. *Hoses, exposed pipes and hydraulic tank breathers.*
 - 1.12.2. *Filters.*
 - 1.12.3. *Rubber mountings.*
 - 1.12.4. *External electric wiring.*
 - 1.12.5. *Bearings and seals*
 - 1.12.6. *External Cables, Linkages*
 - 1.12.7. *Loose/Corroded Connections, Light Units, LED's*
 - 1.12.8. *Comfort items such as Operator Seat, Ventilation, Audio Equipment*
- 1.13. *All service work, particularly filter changes, must be carried out in accordance with the manufacturer's service schedule. Failure to comply will invalidate the warranty. In the event of a claim, proof of the service work being carried out may be required.*
- 1.14. *Repeat or additional repairs resulting from incorrect diagnosis or poor quality previous repair work are excluded from warranty.*

NB Warranty cover will be invalid if any non-genuine parts have been fitted or used. Use of non-genuine parts may seriously affect the machine's performance and safety. McConnell Ltd cannot be held responsible for any failures or safety implications that arise due to the use of non-genuine parts.

2. REMEDIES AND PROCEDURES

- 2.01. *The warranty is not effective unless the Selling Dealer registers the machine, via the McConnell web site and confirms the registration to the purchaser by completing the confirmation form in the operator's manual.*
- 2.02. *Any fault must be reported to an authorised McConnell Ltd dealer as soon as it occurs. Continued use of a machine, after a fault has occurred, can result in further component failure for which McConnell Ltd cannot be held liable.*
- 2.03. *Repairs should be undertaken within two days of the failure. Claims submitted for repairs undertaken more than 2 weeks after a failure has occurred, or 2 days after the parts were supplied will be rejected, unless the delay has been authorised by McConnell Ltd. Please note that failure by the customer to release the machine for repair will not be accepted as a reason for delay in repair or submitting warranty claims.*
- 2.04. *All claims must be submitted, by an authorised McConnell Ltd Service Dealer, within 30 days of the date of repair.*
- 2.05. *Following examination of the claim and parts, McConnell Ltd will pay, at their discretion, for any valid claim the invoiced cost of any parts supplied by McConnell Ltd and appropriate labour and mileage allowances if applicable.*
- 2.06. *The submission of a claim is not a guarantee of payment.*
- 2.07. *Any decision reached by McConnell Ltd. is final.*

3. LIMITATION OF LIABILITY

- 3.01. *McConnell Ltd disclaims any express (except as set forth herein) and implied warranties with respect to the goods including, but not limited to, merchantability and fitness for a particular purpose.*
- 3.02. *McConnell Ltd makes no warranty as to the design, capability, capacity or suitability for use of the goods.*
- 3.03. *Except as provided herein, McConnell Ltd shall have no liability or responsibility to the purchaser or any other person or entity with respect to any liability, loss, or damage caused or alleged to be caused directly or indirectly by the goods including, but not limited to, any indirect, special, consequential, or incidental damages resulting from the use or operation of the goods or any breach of this warranty. Notwithstanding the above limitations and warranties, the manufacturer's liability hereunder for damages incurred by the purchaser or others shall not exceed the price of the goods.*
- 3.04. *No action arising out of any claimed breach of this warranty or transactions under this warranty may be brought more than one (1) year after the cause of the action has occurred.*

4. MISCELLANEOUS

- 4.01. McConnel Ltd may waive compliance with any of the terms of this limited warranty, but no waiver of any terms shall be deemed to be a waiver of any other term.*
- 4.02. If any provision of this limited warranty shall violate any applicable law and is held to be unenforceable, then the invalidity of such provision shall not invalidate any other provisions herein.*
- 4.03. Applicable law may provide rights and benefits to the purchaser in addition to those provided herein.*

McConnel Limited



For Safety and Performance...

ALWAYS READ THE BOOK FIRST



TWOSE

**Temeside Works
Ludlow
Shropshire
England**

**Telephone: +44 (0)1584 873131
www.twose.com**

In line with our policy of constant improvement, this publication will be periodically updated; to ensure you have access to the latest version of this manual please visit the manuals library on our website where an 'up-to-date' version can be referenced online, or downloaded. <https://my.mcconnel.com/service/pdf-manuals/>

CONTENTS

1 - GENERAL DESCRIPTION	4
1.1 - PRELIMINARY INFORMATION	4
1.2 - TRAINING REQUIRED OF THE OPERATOR	5
1.3 - INSTRUCTIONS FOR USE AND STORAGE	5
1.4 - INTRODUCTION	6
1.4.1 - UPDATES TO THE MANUAL	6
1.4.2 - COPYRIGHT	6
1.5 - WARRANTY	6
1.6 - LIABILITY	7
1.7 - PERMITTED USES	7
1.8 - IMPROPER OR NON-PERMITTED USES	8
1.9 - RUNNING IN AND TESTING THE MACHINE	9
1.10 - FOR YOUR SAFETY	9
2 - MACHINE CHARACTERISTICS	10
2.1 - MACHINE DESCRIPTION	10
2.2 - STANDARDS FOLLOWED	10
2.3 - IDENTIFICATION OF THE MACHINE	11
2.3.1 - MACHINE DIRECTIONS	11
2.4 - NOISE LEVEL	12
3 - SAFETY INSTRUCTIONS	13
3.1 - GENERAL SAFETY RULES	13
3.1.1 - FULLY UNDERSTANDING THE MACHINE	13
3.1.2 - WEARING PROTECTIVE CLOTHING	13
3.1.3 - INSTRUCTIONS FOR CARRYING OUT INSPECTION AND MAINTENANCE	13
3.1.4 - INSPECTING THE MACHINE	14
3.2 - GENERAL PRECAUTIONS	14
3.2.1 - SAFETY INSTRUCTIONS	15
3.2.2 - ROAD SAFETY REGULATIONS	15
3.2.3 - OPERATIONAL SAFETY	16
3.2.4 - SAFETY RULES DURING USE	16
3.2.5 - SAFETY RULES REGARDING THE HYDRAULIC SYSTEM	17
3.2.6 - LOCATION OF THE SAFETY PLATES	18
3.2.7 - DESCRIPTION OF THE SAFETY PLATES	19
3.3 - SAFETY DURING MAINTENANCE	20
3.3.1 - CARE AND MAINTENANCE	20
3.3.2 - WARNING PLATES	21
3.3.3 - TOOLS	21
3.3.4 - PERSONNEL	22
3.3.5 - KEEPING THE MACHINE CLEAN	22
3.3.6 - PERIODIC REPLACEMENT OF ESSENTIAL SAFETY COMPONENTS	22
4 - TECHNICAL DATA	23
4.1 - DIMENSIONS AND WEIGHTS	23

4.2 - TECHNICAL CHARACTERISTICS	23
4.3 - ROTOR TYPES	23
4.4 - PARTS NOMENCLATURE	24

5 - TERMINOLOGY 26

5.1 - DEFINITION OF THE TERMS USED	26
------------------------------------	----

6 - USING THE MACHINE 27

6.1 - PRELIMINARY CHECKS	27
6.2 - CHECKS TO BE PERFORMED AT THE START OF EACH WORKING DAY	27
6.3 - COUPLING THE MULCHING HEAD	28
6.4 - TRANSMITTER UNIT	31
6.4.1 - OPERATING THE TOOL	31
6.4.2 - STOPPING THE TOOL	32
6.4.3 - OPENING THE SAFETY GUARD (AUX 1)	32
6.4.4 - LIFTER	33
6.5 - ADJUSTING THE CUTTING HEIGHT	34
6.6 - ADJUSTING THE END STOPS	35
6.7 - FAULTS, CAUSES AND SOLUTIONS	36

7 - TRANSPORT AND HANDLING 37

7.1 - LIFTING	37
---------------	----

8 - STORAGE 39

8.1 - BEFORE USE OR PUTTING BACK INTO SERVICE AFTER A LONG PERIOD OF INACTIVITY	39
8.2 - DISMANTLING AND DECOMMISSIONING	40

9 - MAINTENANCE 41

9.1 - INTRODUCTION	41
9.2 - GENERAL INSTRUCTIONS	41
9.3 - EXTRAORDINARY MAINTENANCE	42
9.4 - LUBRICANTS AND FLUIDS TABLE	42
9.4.1 - GREASES TABLE	42
9.5 - DAILY MAINTENANCE	42
9.5.1 - CLEANING THE MACHINE	42
9.6 - TRANSMISSION MAINTENANCE	43
9.6.1 - BELT TENSIONING	43
9.6.2 - REPLACING THE BELTS	45
9.7 - ROTOR MAINTENANCE	46
9.7.1 - REPLACING THE ROTOR	46
9.7.2 - REPLACING THE ROTOR SUPPORT BEARINGS	50
9.7.3 - CHECK THE CUTTING FLAILS	52
9.7.4 - REPLACING THE CUTTING TOOLS	52
9.8 - SUPPORT ROLLER MAINTENANCE	53

9.9 - GUARD MAINTENANCE	54
9.9.1 - REPLACING THE RUBBER FLAPS	54
9.10 - LUBRICATION	55
9.10.1 - GREASING THE COUPLING	55
9.10.2 - GREASING THE ROTOR SUPPORTS	55
9.10.3 - GREASING THE SUPPORT ROLLER	56
9.10.4 - GREASING THE SAFETY GUARD OPENING CYLINDER	56
9.11 - PERIODIC COMPONENT REPLACEMENT	57
9.12 - MAINTENANCE OPERATIONS	57

10 - INSTRUCTIONS FOR EMERGENCY SITUATIONS 58

10.1 - FIRE	58
-------------	----

11 - TIGHTENING CHART 59

11.1 - COARSE PITCH BOLTS	59
11.2 - FINE PITCH BOLTS	60
11.3 - FITTINGS TIGHTENING CHART	61

12 - NOTES 62

1 - GENERAL DESCRIPTION

1.1 - PRELIMINARY INFORMATION

This is the machine use and maintenance instruction manual and is compliant under:

- Directive Machine 2006/42/EC and subsequent amendments and additions.
- Statutory instruments 2008 No. 1597.

Do not destroy or modify it and only supplement it with additional files.

Publication: **1010**
 Part No.: **24215.10**
 Issued: **11/2021**
 Machine type: **Grass / Mulching Head**



Twose is a trading name of McConnel

The manual is valid from serial number: **M2166819**

Twose, Temeside Works, Ludlow, Shropshire, SY8 1JL, UK

Tel: +44 (0)1584 873131 Email: sales@twose.com Website: www.twose.com

AS SUPPLIED (Hood Ram Spacer)

The flail head is fitted with a hydraulic ram to allow movement of the hinged hood. The movement of this ram is restricted with an internal spacer. This is to stop operators inadvertently opening the hood when cutting alongside the highway. This reduces the risk to passing traffic from being hit by objects ejected at speed from the working flail head. It should be noted that with the hinged hood opened objects could be thrown a considerable distance. Being struck by a thrown object could result in injury or death.

If the machine is being used away from the highway, other vehicles and bystanders are not normally in the vicinity then the spacer can be removed provided the general safety information and specific following conditions are met;

- A detailed work area and bystander risk assessment is undertaken before work begins.
- The operator has been trained in the safe use of the SlopeTrak, including safe retrieval of the unit from any situation where it could become stuck or trapped.
- The hydraulic ram is returned to the approved version after usage away from the highway and before the re-sale to another party.



1.2 - TRAINING REQUIRED OF THE OPERATOR

Reading this manual thoroughly:

- All machine operators and maintenance personnel must read this entire manual thoroughly and carefully and follow the instructions provided.
- It is the duty of the employer to ensure that operators possess the skills required to operate the machine and that they have read this manual carefully.

1.3 - INSTRUCTIONS FOR USE AND STORAGE

The operating instructions contained in this manual apply to the Twose SLOPETRAK 400/500 FLAILHEAD.

This instruction manual must be read and used as follows:

- The instructions manual must be considered an integral part of the machine and must be read carefully;
- The instruction manual must be easily accessible to operators and maintenance technicians;
- Keep the manual for the entire lifetime of the machine;
- Ensure that any updates are incorporated in the manual;
- Give the manual to any other user or subsequent owner of the machine;
- Use the manual in such a way as not to damage it or its contents;
- Do not remove, tear out or rewrite any part of the manual for any reason;
- Keep the manual away from moisture and heat;
- In the event that the manual is lost or partially damaged, or it is otherwise not possible to read part or all of its content, a new copy should be requested from the manufacturer.

Pay maximum attention to the following symbols and their meanings, they serve to highlight particular information such as:

CAUTION



Refers to supplements or suggestions for correct use of the machine.

WARNING



Refers to dangerous situations which can occur when using the machine, that could cause serious injuries or property damage.

DANGER



Refers to dangerous situations that may arise when using the machine, which if not avoided, could cause serious injuries or death.

1.4 - INTRODUCTION

The service standards outlined in this manual represent an integral part of the machine supply contract. These instructions are also addressed to operators already specifically trained to operate this kind of machinery and contain all information necessary and essential for safe operation and correct/optimal use of the machine. Rushed and incomplete preparations lead to improvisation, the cause of many accidents.

Read the following suggestions carefully and put them into practice before starting work:

- Familiarise yourself with all the operations that can be performed and work positions before manoeuvring the machine;
- The instructions manual must be available to the operator at all times;
- Programme all interventions carefully;
- Get all the information necessary for the transporting the machine on the road such as distance, route, height of level crossing, bridge capacity etc.
- Know in-depth where and how the machine is intended to be used: ground load capacity.
- Before starting work, make sure that the safety devices are working correctly and that there are no doubts regarding their functionality. If they are not working correctly or you have doubts, do not under any circumstances use the machine;
- Carefully follow the warnings regarding specific hazards indicated in this manual;
- Regular and thorough preventive maintenance will guarantee that the machine is always at its highest possible level of operational safety. Never put off the necessary operations, and ensure they are performed exclusively by specialised personnel, using only original spare parts.

1.4.1 - UPDATES TO THE MANUAL

The information, the descriptions and the illustrations contained in this manual reflect the state of the art at the moment the machine was sold.

The manufacturer reserves the right to make modifications to its products at any time for technical or commercial reasons. In the event that such modifications are made, the Manufacturer is under no obligation (for safety reasons) to modify the other machines sold up to that moment or issue updates to the manual. Moreover, this publication shall not be considered lacking in any way.

Any supplements that the Manufacturer considers appropriate to supply at a later date must be kept together with the manual and considered an integral part of it.

1.4.2 - COPYRIGHT

The copyright of this manual belongs to the machine's manufacturer. This manual contains technical texts, drawings and illustrations which may not be divulged or transmitted to third parties, in whole or in part, without the written authorisation of the machine manufacturer.

1.5 - WARRANTY

Materials supplied by McConnel are covered by a 12-month warranty from the date of commissioning as indicated on the delivery note. In any case, refer to the machine order confirmation for special arrangements agreed during the sale.

McConnel reserves the right to repair, or substitute, the pieces it agrees are defective during the warranty period.

By replacing the defective part, McConnel shall consider itself absolved from any other expense borne by the Dealer and the Dealer's Customer, for instance presumed damages, either present or future, such as lost earnings, liquidated damages, etc.

Scheduled and extraordinary maintenance must be performed in accordance with the instructions given in this manual. For all the cases not included and for any type of customer assistance, please contact McConnel directly by registered letter or fax even if agreements have already been made by telephone. McConnel does not accept any liability for any delays or the failure to carry out work. McConnel shall not be held liable for any damage or malfunctions due to work of a technical nature being carried out on the machine by unauthorised personnel.

1.6 - LIABILITY

McConnel shall not be held liable for any accidents involving personal injury or damage to property that may occur due to:

- Failure to comply with the instructions provided in this manual regarding the operation, use and maintenance of the machine.
- Abrupt movements or incorrect manoeuvres when operating or carrying out maintenance on the machine.
- Modifications made to the machine without the prior written authorisation from McConnel.
- Events that fall outside the normal and correct use of the machine.

In any event, should the user ascribe any incident or accident to a machine defect, they must be able to demonstrate that the consequent damage was a principal and direct consequence of such a defect. Any tampering with the machine or the use of non-original spare parts can be grounds for voiding the warranty and put the operator's safety at risk.

WARNING



- **Always use original spare parts for repairs and maintenance.**
- **McConnel shall not be held liable for any damage as a result of failure to follow the above instructions.**
- **The machine is guaranteed according to the contractual agreements specified at the time of sale.**
- **The warranty will lapse if the regulations and instructions laid out in this manual are not followed.**

1.7 - PERMITTED USES

The FLAILHEAD mulching head has been designed for professional use, mainly for green area maintenance and cutting plants or plant material found on the ground such as grass, reeds, bushes and shrubs having a maximum stem diameter of 3 cm.

The machine uses the high rotation speed of the flails to cut the materials and is operated by a hydraulic motor via a hydrostatic transmission driven by a belt wound between two pulleys.

The equipment must not be used with the mulching head raised from the ground and/or without its safety guards installed.

Any other use shall be considered inappropriate, and the manufacturer shall not be held responsible for any damage to the machine or other property, or for injuries which may result.

The machine is suitable for shredding bushes at speeds of up to 4-5 km/h.

This machine should generally be used during daylight hours. If, under exceptional circumstances, it has to be used at night or in conditions of reduced visibility, an auxiliary lighting system must be used. Always operate in daylight or with artificial lighting that guarantees visibility of at least 100 metres.

1.8 - IMPROPER OR NON-PERMITTED USES

WARNING



This section indicates some of the uses considered improper or otherwise not permitted. Because it is impossible to predict all possible improper uses, in the event that you wish to use the machine for uses other than those indicated, contact McConnel before carrying out any work.

The following uses must always and absolutely be avoided:

- Use of the machine by minors, inexperienced, or untrained persons.
- Use of the machine to lift and/or transport persons or things.
- Use of the mulching head as a piledriver.
- Use of the machine to tow accident-damaged vehicles.
- Use of the machine to shred brushwood and shrubs with diameter greater than 3 cm.
- It must not be used on surfaces on which there is glass, loose stones, pieces of metal or other foreign bodies that could be thrown into the air by the blades or damage the mulching head.
- Lifting or pulling loads;
- Putting the machine in contact with materials classified as dangerous due to their chemical or physical properties (e.g. flammable, toxic, explosive materials).
- Overloading the machine beyond its permitted limits.
- Using the machine with tools that have not been authorised by McConnel.
- Make modifications to the machine (hydraulic, electric or mechanical).

DANGER



Use of the machine without suitable safety guards can be dangerous both for the operator and for people or animals that are within range of the working machine.

1.9 - RUNNING IN AND TESTING THE MACHINE

Every machine is scrupulously adjusted and tested before delivery.

A new machine must however be used with caution for the first 100 hours to allow 'running-in' of the various components.

If the machine is subjected to an excessive work load when it is first used, its performance may be affected and its functionality reduced within a short space of time.

During the 'running-in' period, pay great attention to the following points:

- After start-up, allow the engine to turn at a low number of revs for 5-6 minutes;
- Avoid operating machine at its maximum capacity for the first 100 hours of operation. Avoid sudden acceleration or deceleration.

1.10 - FOR YOUR SAFETY

- Never remove the safety guards when the mulching head and/or its accessories are moving.
- When the mulching head is in operation, it is recommended to remain at a safe distance of 50 metres and to make sure that there are no people or animals within the danger area of the machine. If people or animals enter the danger area, stop machine functions immediately.
- The tools must never touch the ground during operation.
- Before carrying out any work on the mulching head, for example cleaning or maintenance, stop the hydraulic motor, wait for the rotor to come to a complete stop and switch off the engine.
- Do not carry people on the machine while it is being transported or being used.
- When the rotors are rotating, do not attempt to introduce or remove materials in any way, and especially not using your hands or feet.
- Do not lift the mulching head when the rotor is moving, otherwise there is a danger of materials being ejected at high speed.

WARNING



- **For reasons of safety, self-adhesive warning/information decals are affixed to the machine, these must be replaced immediately if they become illegible.**
- **The operator must not be someone who only works occasionally on this machine; he/she must be experienced with this type of machine and therefore trained to use it.**
- **Whenever direct visibility of the work zone from the control station is not sufficient, the operator must be assisted by a specifically assigned person.**
- **In order to be safe, the person assisting the operator must always stand to the side of the machine at a safe distance (more than 50 meters), NEVER in front of or behind it.**
- **Check the condition and operation of any part subject to wear daily: (pins, valves, piping, etc.). When necessary, replace with original parts.**
- **Do not, for any reason, tamper with the hydraulic system and under no circumstances should any seals be removed from the valves as this will void all warranties. Contact an authorised McConnel repair centre if the valves require adjustment.**

2 - MACHINE CHARACTERISTICS

2.1 - MACHINE DESCRIPTION

The FLAILHEAD mulching head has been designed for professional use for mowing grass and shrubs up to a diameter of 3 cm.

It should always be used away from people, public roads, and buildings etc.

The use of the equipment for uses other than the intended ones, and which does not comply with what is written in this manual releases McConel from any direct and/or indirect liability.

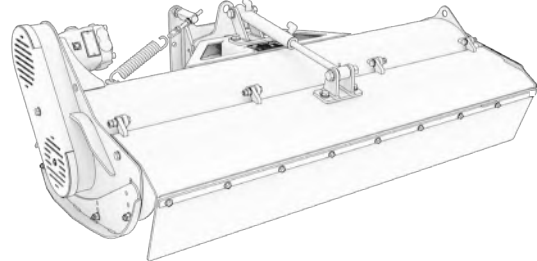

2.2 - STANDARDS FOLLOWED

The machine was designed and constructed in compliance with EC directives as regards safety and approximation of the laws of the Member States, specifically the Machinery Directive 2006/42/EC, where applicable.

The following Standards were also taken into account during the machine's design:

- UNI EN ISO 12100:2010 "safety of machinery"

The following technical specifications were used for updating the machine:

- ISO 3767-1:2016
- ISO 11684:1995.
- ISO 3864-3:2012

2.3 - IDENTIFICATION OF THE MACHINE

The machine identification plate (A) is fastened at the centre of the frame.
The serial number (B) and year of manufacture should always be quoted when requesting replacement parts for the machine.

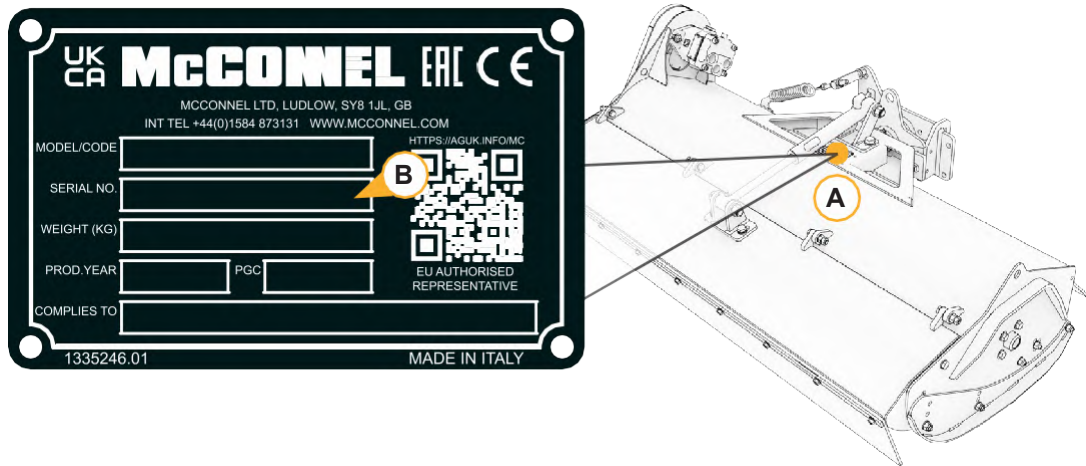

CAUTION



The serial number and year of manufacture must always be quoted to assist the request for replacement parts.

2.3.1 - MACHINE DIRECTIONS

The terms 'left' and 'right' are used in respect of the operating direction of the machine.

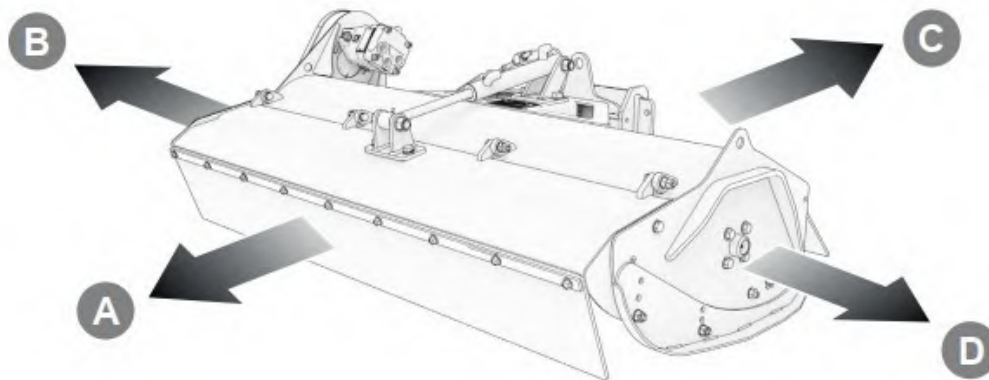

- A) Forwards (working direction)
- B) Right side
- C) Backwards
- D) Left side

2.4 - NOISE LEVEL

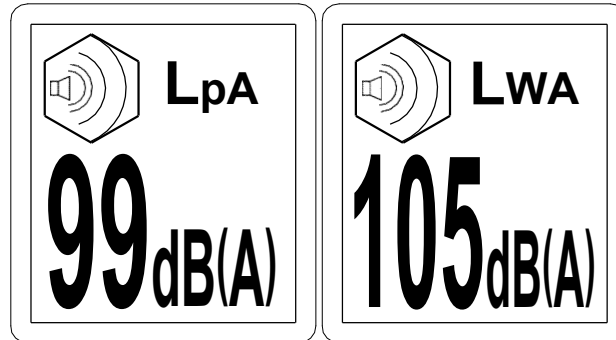

LpA = This value indicates the maximum sound level perceived by the operator calculated by making a worst case assessment at the four points around the machine being tested.

Lwa = This value indicates the sound level outside the machine and refers to the noise perceived by those who are in the vicinity of the work area.

Standards:

- S.I. 2008 No. 1597;

WARNING



ALWAYS WEAR EAR DEFENDERS WHEN OPERATING THE MACHINE; THE MEASURED NOISE VALUES REQUIRE USE OF NOISE PROTECTION DEVICES.



3 - SAFETY INSTRUCTIONS

3.1 - GENERAL SAFETY RULES

3.1.1 - FULLY UNDERSTANDING THE MACHINE

The machine must only be used by qualified personnel familiar with all aspects of its operation.

3.1.2 - WEARING PROTECTIVE CLOTHING

Wear tight-fitting clothing and use safety equipment which meets applicable regulations. In particular the following items should be worn:

- Noise protection gear
- Safety footwear
- Overalls
- Work gloves



During use, the machine may cause dust emissions. If you are working in dry or dusty conditions it is recommended that you wear the following personal protective equipment:

- Protective eyewear
- Respiratory protection dust mask

3.1.3 - INSTRUCTIONS FOR CARRYING OUT INSPECTION AND MAINTENANCE

When maintenance is being carried out on the machine:

- Remove the ignition key from the machine prior to inspection or maintenance.
- Place a "DO NOT START ENGINE" sign on the machine in a clearly visible position.
- Delimit the area with road cones.
- Before performing maintenance, make sure that you know which operations have to be carried out.
- In the case of an extraordinary maintenance where the machine or parts of it have to be lifted, go to a service centre that is equipped with suitable lifting devices.
- If carrying out ordinary maintenance, position the head on level ground and make sure that the machine cannot move.

3.1.4 - INSPECTING THE MACHINE

- Inspect the machine thoroughly every day before using it, checking the condition and functionality of parts that are subject to wear: (pins, valves, piping, etc.). When necessary, replace worn, damaged, or defective components with genuine parts.
- Only start the engine in a well ventilated area and ensure no persons or animals are within the operating range of the machine.
- Covers and safety devices must not be removed; they are designed and manufactured for your safety.
- Do not use the machine if the safety devices or covers are damaged or missing.
- Make sure all safety devices are put back in place immediately after cleaning or repair work has been carried out.
- Keep the machine and all its accessories clean and in good working order at all times, remove any cut material debris that has been deposited on the machine.

WARNING



- **It is strictly prohibited to make changes to the machine without the prior authorisation of the manufacturer.**
- **Changes to the machine can cause hazards and injuries.**
- **The manufacturer shall not be held responsible for the machine if these instructions are not followed.**

3.2 - GENERAL PRECAUTIONS

- Operators must not be occasional users, but those who have a certain amount of experience with this type of machine.
- An operator is a person trained to work with this type of machine and/or equipment.
- It is mandatory to read and follow the instructions indicated in this manual before performing any operation or manoeuvre with the machine. It is too late to do so while working. Improper use or an incorrect manoeuvre can result in serious damage to persons or property.
- Operators and maintenance technicians must be fully familiar with the machine, especially regarding the dangers associated with misuse or performing poor or incorrect repairs.
- Whenever direct visibility of the work zone from the control station is not sufficient, the operator must be assisted by a specifically assigned person.
- Before starting up the equipment, carry out all the checks on self-propelled vehicles regarding:
 1. Operation
 2. Road safety
 3. Accident prevention regulations
 4. Safety guards
- Even when the machine is being used correctly, stones or other items can be thrown a considerable distance by the machine. **Therefore, there must not be anyone within the danger area of 50 metres.** Pay great attention when working near roads or buildings.
- Before beginning a day's work, always check the condition of the tools and all the guards. If they are damaged or missing, replace them.
- Make sure that nobody can start the machine by mistake whilst the machine is being inspected or repairs are being carried out.

- Do not wear loose clothing.
- Never use the mulching head to lift persons or things.
- Do not work, walk or stand under the raised mulching head.
- Never carry persons on the mulching head.
- Never stand next to the tool unless it has come to a complete stop.
- Before starting the machine, make sure that there are no people and/or animals within the range of action of the machine.
- Before leaving the machine unattended, proceed as follows:
 1. Make sure that no functions can be activated.
 2. Stop the machine and put the brake on. In the case of steep slopes, insert the wheel chocks.
 3. Turn off the engine and remove the ignition key.
- Replace any missing or worn warning decals or pictograms immediately.
- Never underrate or ignore safety regulations.
- If any safety devices are damaged or not working, replace them immediately.

3.2.1 - SAFETY INSTRUCTIONS

The machine has been designed and constructed according to the current state of the art and technical standards for mowing grass, cutting shrubs and the maintenance of road verges, slopes, canals, drainage ditches etc. Always observe the laws and regulations for operating machines of this type.

The materials and parts used on the equipment, as well as the production procedures, quality guarantee and checks meet the highest safety and reliability standards.

If the machine is used for the purposes specified in this manual, manoeuvred with care and maintenance and servicing is carried out carefully and correctly, the machine can provide constant reliability and high performance for a long period of time.

When being used on public land, comply with all the rules and regulations of the Highway Code for the country in which the machine is being used.

3.2.2 - ROAD SAFETY REGULATIONS

The manufacturer accepts no liability for accidents whilst the machine is being used if the user does not comply with current legislation, directives, recommendations and regulations for machines used for mowing grass, shrubs, the maintenance of roadside verges, slopes, canals, drainage ditches etc.

The machine is designed to work in normal weather conditions at a temperature ranging from -10°C to +40°C. It should therefore only be operated in these conditions.

As regards the mowing on public roads, please refer to the instructions given by the work supervisor as this is a mobile site.

- During road transfers, moderate the speed, especially on uneven roads.
- During the transit on public roads, comply with the applicable regulations.
- Never transport the machine with the tool in operation, even for short distances.

3.2.3 - OPERATIONAL SAFETY

The manufacturer cannot be held responsible in case of malfunction and damage if the machine:

- is used for purposes other than those for which it was intended;
- is not manoeuvred, operated and maintained according to the instructions specified in the manual;
- is not regularly and periodically maintained as indicated, or non-genuine spare parts are used.
- is modified or its equipment is replaced without the written permission of the manufacturer, especially when the efficiency of the safety systems has been reduced or has intentionally been removed.
- is used outside the permitted temperature range and for purpose other than those for which it was designed.

The machine user is responsible for all property damage or personal injuries caused by machine operation.

3.2.4 - SAFETY RULES DURING USE

- When the machine is in operation, take care not to let it come into contact with hard objects such as drain covers, manhole covers, pavements, guard rails, railway tracks, stony ground etc. This could cause the tools to break and they could be projected out of the machine at a dangerously high speed.
- If wire, cables, chains or other objects become caught in the rotor, stop immediately to avoid damage or dangerous situations. Stop the machine, switch off the engine and remove the key. Using work gloves, remove any materials that have been caught in the rotor with the aid of pliers, shears or other suitable implement.
- Do not continue to use the mulching head if there are vibrations that could lead to breakage and/or serious damage. Ascertain the cause of such problem and eliminate it.
- It is forbidden to carry out maintenance, cleaning, adjustments or similar operations on any part of the machine or the interchangeable equipment connected to it when the machine is running. Any maintenance, cleaning or adjustments must always be carried out with the engine switched off.
- During operation, pay attention to any electrical cables, especially if you need to pass under them as this can cause loss of radio signal. When this situation occurs, the machine will immediately switch off the engine and stop.
- Before raising/lowering the equipment ensure nobody is within 50 meters of the machine.

DANGER



- **Do not try to free a blocked rotor by reversing its cutting direction.**
- **Danger of projection of materials.**

In case of danger; press the emergency stop button on the machine and/or on the radio control unit.

NOTE: the two emergency buttons do not have the same function; the one on the radio control unit allows all the machine functions to be stopped while keeping the engine running, the one on the machine will stop functions and switch off the engine.

DANGER



If there is a dangerous situation that requires the entire machine to be switched off, press the emergency stop button on the radio control unit and switch off the engine. Otherwise, press the emergency stop button on the machine.

3.2.5 - SAFETY RULES REGARDING THE HYDRAULIC SYSTEM

- Stop immediately if you notice oil leaks.
- Periodically check the hoses. If they are worn, contact your McConnel dealer for replacements.
- Before performing any work on the hydraulic system, rest the machine on the ground and switch off the engine.
- Used oils and greases must be disposed in accordance with pollution prevention regulations.
- Do not, for any reason, tamper with the hydraulic system and never remove seals from valves; this will void all warranties. Contact an authorised McConnel dealer if the valves should require adjustment.
- Excessive heating of the oil can damage the seals in the hydraulic circuit and may lead to the deterioration of the fluid itself. Heating of oil can be caused when pressure relief valves operate for extended periods; therefore, avoid prolonged operation of hydraulic rams when they are at their end stop position.

CAUTION



- **Do not look for oil leakages with your bare hands or other parts of your body. Use cardboard or rags to identify the leak.**
- **Always wear waterproof gloves and safety goggles.**
- **Wait for the oil to cool down before performing any repairs or maintenance.**
- **Bleed out the oil pressure before disconnecting pipes or during maintenance of the system.**
- **High pressure oil can penetrate the skin and cause serious infections. If this happens, see a physician immediately.**
- **These operations must be performed by authorised and suitably trained personnel.**

WARNING



Replace the hydraulic pipes if they are worn or damaged, and renew at least every 6 years.

3.2.7 - DESCRIPTION OF THE SAFETY DECALS

CAUTION



Ensure that the safety decals are in good condition. If the decals are damaged, they must be replaced with original decals that can be obtained from McConnell and placed in the position indicated in the manual. Make sure that the safety decals are readable. Clean them using a damp cloth dipped in soap and water.

Hazard Warning

Read the documentation that comes with the machine before using it.

Hazard Warning - Rotating Tools

Risk of injury to the upper or lower limbs. Make sure that the rotor has stopped before carrying out maintenance on the machine and keep to the safety distance when the machine is in operation.



Danger Sign - Flying Objects

This indicates that stones or other objects may be thrown out by the machine and instructs you to work at a safe distance from the machine.

Lifting Point Decal

Indicates the lifting points on the machine.



Greasing Point Decal

Indicates the greasing points on the machine. Grease as described in the manual.



Greasing Point Decal

Indicates the greasing points on the machine. Indicates it must be greased every 4 hours.



Hazard Warning

Do not stand or transit within the machine operating range.



3.3 - SAFETY DURING MAINTENANCE

3.3.1 - CARE AND MAINTENANCE

The cause of many damages and accidents can be attributed to mistakes or lack of maintenance, such as:

1. Lack of oil, grease.
 2. Lack of cleaning.
 3. Lack of hydraulic system maintenance (damaged hoses, loose fittings etc.).
 4. Poor maintenance or systems modified without authorization.
 5. Working on stony ground or terrain in which material may be thrown at high speed.
- Remember that all maintenance must be carried out by trained, qualified personnel, with the machine switched off and stationary.
 - Maintenance and repair operations must not be performed outdoors, but in an appropriately equipped workshop.
 - The operator must wear Personal Protective Equipment (PPE) when using, adjusting, maintaining, repairing or handling the equipment.
 - The used oil must be collected and must not be dumped or poured down the drain, as it is classified as hazardous waste and must therefore be disposed of at an authorised facility. Take used hydraulic fluid to a dump/recycling facility equipped to handle this product.

The following operations must be performed before starting any maintenance:

- The machine must be positioned on flat, firm ground during maintenance work.
- Turn off the machine engine and remove the ignition key.
- Put in place all accident prevention measures required for the type of operation to be performed.
- If compressed air is to be used to clean the machine, the operators must protect themselves with goggles and a dust mask.
- Do not carry out repairs you are not familiar with. Always follow the instructions; if these are not available, contact the supplier or an expert.
- Before starting maintenance work, make sure that any potentially hot parts have cooled down.
- Caution: replace the hydraulic pipes whenever they are damaged, and in any case at least every 6 years.
- Only use the specified lifting points.
- Make sure that the lifting equipment chosen is able to carry out the required operations in compliance with safety regulations.
- Before carrying out work underneath suspended components, or the machine if it is raised from the ground, make the machine safe using supports or stands of appropriate capacity for the weight of the components.
- Do not leave the tractor engine running in enclosed environments that are not equipped with an exhaust gas extraction system.
- Avoid prolonged or repeated contact of fuels/lubricants/other fluids with the skin, as these could cause skin irritations or other symptoms.
- Never swallow fuels/lubricants/other fluids. In the event of accidental contact with the eyes, rinse thoroughly with water.
- Never weld in enclosed or unventilated areas.
- Never weld painted surfaces, or surrounding areas, to avoid toxic vapours being generated.

- Remove any paint with appropriate products, then wash the area and allow it to dry.
- Discharge pressurised circuits before performing work on them.
- Never use your hands to find leaks of pressurised fluids.
- High-pressure fluid leaks can penetrate the skin and eyes, with very serious consequences.
- The operations described below do not require any specialisation. The operator must be aware of the instructions and follow them precisely and must have taken the machine out of service.
- The periodic checks and maintenance operations must be performed in the established manner and at the specified time intervals and are the responsibility of the operator.
- Failure to follow the maintenance intervals and standards prejudices correct operation of the machine and its working lifetime, and as a consequence the validity of the warranty shall lapse.
- Increase the maintenance frequency in demanding working conditions (frequent stops and starts, long winters etc.).
- Never leave the operating position when the machine is on.
- **WARNING:** Due to vibrations, regularly check that all screw connections are firmly tightened. This check must be carried out the first time after 8 hours of operation. Mower blade fasteners must also be checked on a regular basis and retighten 'as and when' required.
- If for any reason the flail rotor starts to vibrate, stop the machine immediately and restore the balance. McConnell declines any responsibility for injury to people or damage to property caused by the operator's failure to comply with these instructions.
- Clean the machine after use. Do not use petrol or solvent-based products to clean the machine. Do not clean electrical parts with water under pressure.
- During operation, and in particular in windy conditions, the user must carefully choose his position in order not to be exposed to exhaust gases, dust or mown grass.
- Do not operate the machine if you are unable to see it (behind ridges, corners of buildings, tall grass etc.).

3.3.2 - WARNING PLATES

Position the machine on a firm and flat surface, rest the equipment on the ground and turn off the engine before performing any maintenance operation. If other persons start the engine and activate the control levers while maintenance works are being carried out, serious injuries or death can result. To avoid these dangers, before carrying out the maintenance, put the radio control in a safe position, remove its battery and hang warning signs on the machine.



3.3.3 - TOOLS

Use only tools specified by the machine manufacturer to prevent personal injuries, do not use worn, damaged, low quality, or makeshift tools.

3.3.4 - PERSONNEL

The routine maintenance indicated in the manual must be carried out exclusively by authorised and trained personnel. For the maintenance or overhaul of components that are not specified in this manual, please contact McConnel.

3.3.5 - KEEPING THE MACHINE CLEAN

The cleaning of the mulching head is part of ordinary machine maintenance and must be done in order to be able to check the condition of the machine itself.

3.3.6 - PERIODIC REPLACEMENT OF ESSENTIAL SAFETY COMPONENTS

Periodically check the following components:

- Front and rear rubber flaps. Replace immediately if worn, otherwise any warranty will be become null and void.
- Flails: if cracked or broken they should be replaced (in opposing pairs) otherwise a part of them could be ejected and/or the rotor could become unbalanced and the moving parts of it damaged (bearings etc.).
- Carefully check the condition and cleanliness of the machines 'quick couplers'.
- Even if they appear to be in good condition, some components have to be periodically replaced with new ones as certain components can deteriorate with time.
- If any part is defective, replace or repair it even if it is still not scheduled to be replaced.

4 - TECHNICAL DATA

4.1 - DIMENSIONS AND WEIGHTS

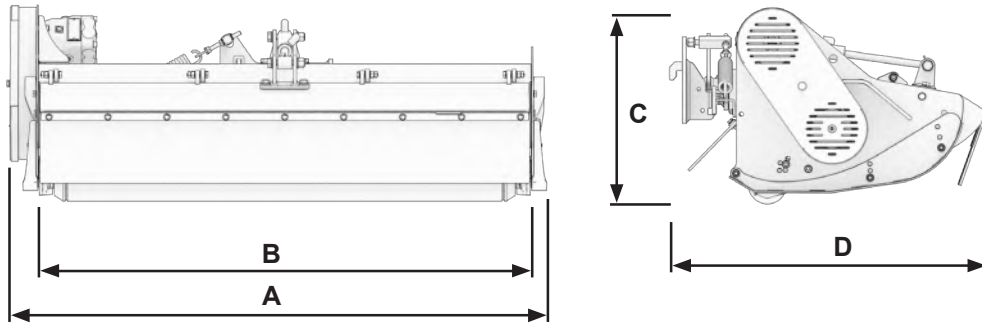

FLAILHEAD		
WIDTH (max)	A	1425 mm
WORKING WIDTH	B	1300 mm
HEIGHT (max)	C	550 mm
DEPTH (max)	D	920 mm
WEIGHT		160 kg

4.2 - TECHNICAL CHARACTERISTICS

FLAILHEAD		
ENGINE	cc	21
	bar	290
TRANSMISSION		Belt driven
ROTOR DIAMETER	mm	300
ROTOR SPEED (min - max)	rpm	2900 - 3050
CUTTING DIAMETER	max	3 cm

4.3 - ROTOR TYPES

ROTOR WITH Y-FLAILS

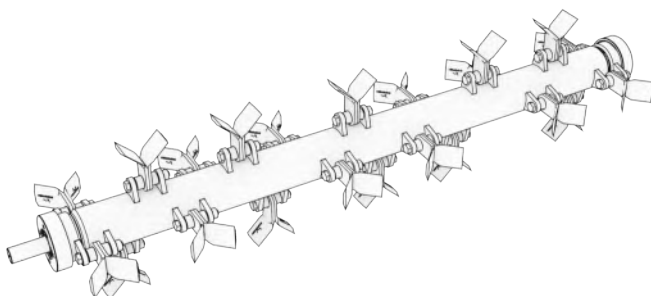

Tooth kit	22
Recommended for cutting:	
Grass / shrubs with a maximum diameter of 3 cm.	

4.4 - PARTS NOMENCLATURE

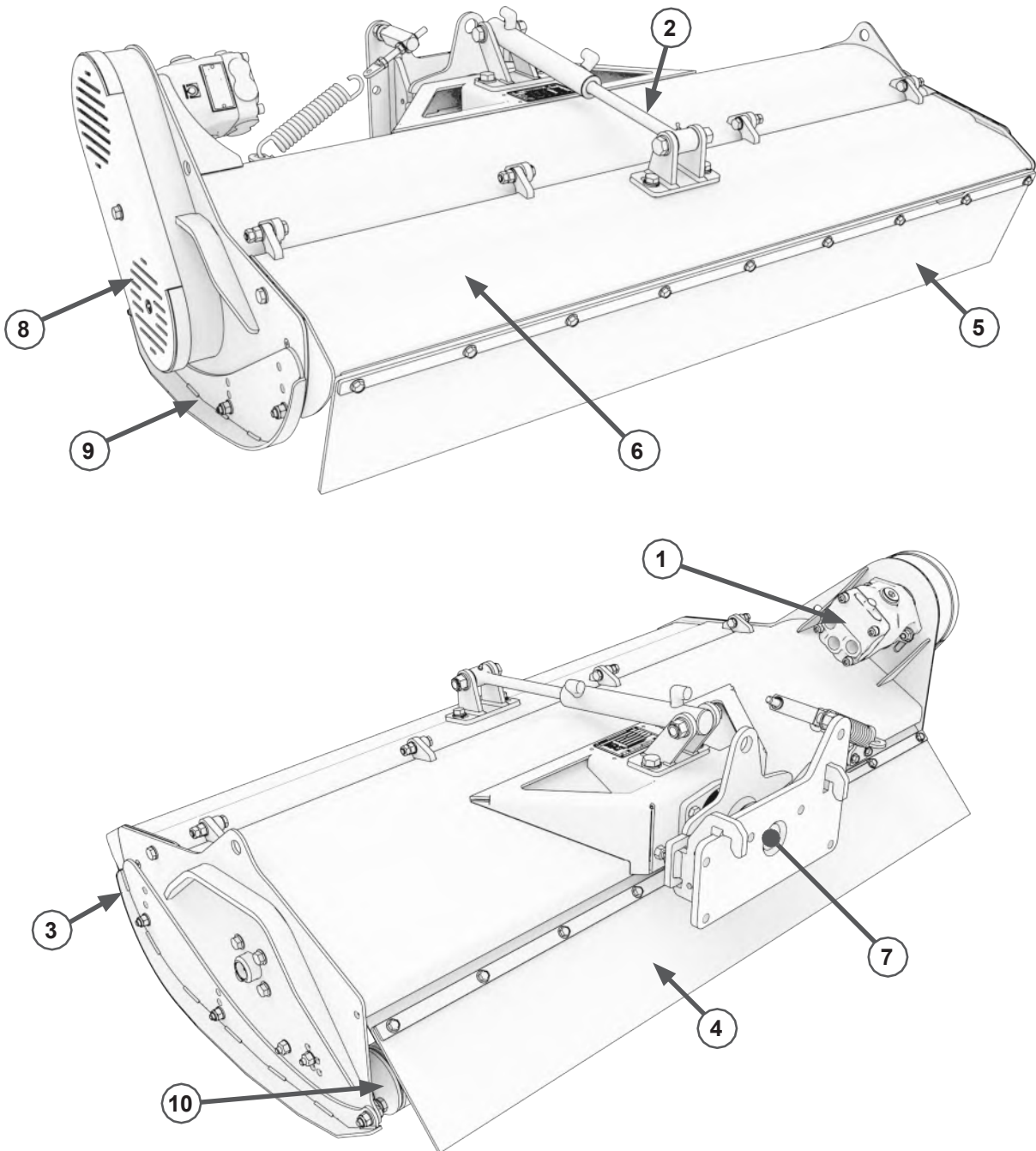

No.	DESCRIPTION	No.	DESCRIPTION
1	Hydraulic motor	6	Front safety bonnet
2	Front safety bonnet opening cylinder	7	Equipment coupling
3	Left skid plate	8	Belt guard
4	Rear rubber flaps	9	Right skid plate
5	Front rubber flaps	10	Support roller

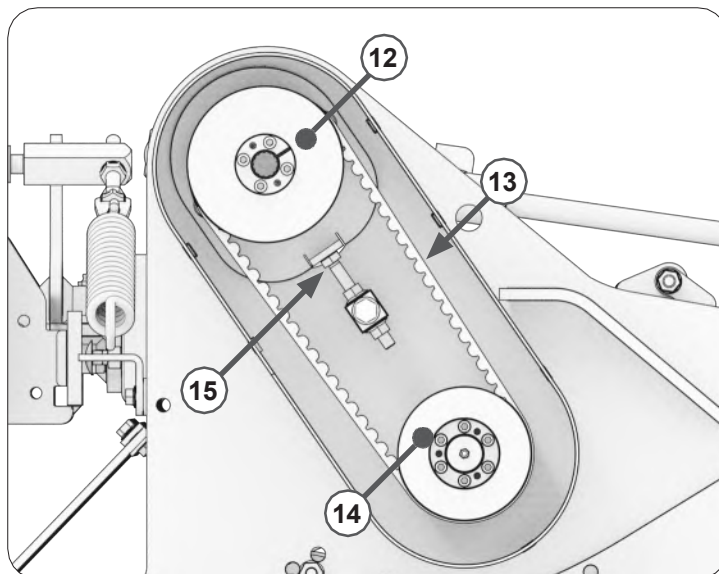

No.	DESCRIPTION
12	Upper pulley
13	Belts
14	Lower pulley
15	Belt tensioner system adjustment screws

5 - TERMINOLOGY

5.1 - DEFINITION OF THE TERMS USED

OPERATOR

Personnel trained to manoeuvre the machine when in operation, to move it and carry out normal machine inspection and cleaning.

Must not have disabilities of any kind or health problems.

SPECIALISED OR MAINTENANCE PERSONNEL

Personnel trained to carry out ordinary maintenance, mounting, disassembly and reassembly of some machine components.

Must not have disabilities of any kind or health problems.

AUTHORISED PERSONNEL

Personnel trained to carry out operations of extraordinary maintenance, mounting, disassembly and reassembly of particular machine components.

They must be authorised in writing by McConnel to carry out work on the machine.

Must not have handicaps of any kind or health problems.

OPERATOR ASSISTANT

Personnel trained to assist the operator with certain machine manoeuvres (manoeuvres on worksites with reduced visibility, loading and unloading from vehicles, using the manual pump etc.) and assists the activities on a mobile worksite (public road verge maintenance).

Must know the main work safety requirements.

AUTHORISED REPAIR WORKSHOP

Repair workshop with personnel trained to carry out extraordinary maintenance, mounting, disassembly and reassembly of specific machine components.

It must be authorised in writing by McConnel to work on the machine.

The operator is asked to refer to standard UNI EN 12100-2010, for the definition of the other terms in this manual.

6 - USING THE MACHINE

6.1 - PRELIMINARY CHECKS

The operator must check that the use and maintenance manual has been supplied with the equipment. In case of resale of the machine, the customer/user must provide the buyer with a copy of the use and maintenance manual, intact and complete, as well as the check register and the registration certificate (if requested).

6.2 - CHECKS TO BE PERFORMED AT THE START OF EACH WORKING DAY

Carry out an external inspection of the machine (joints, hoses, hydraulic components, etc.) and check for any leaks of oil or other liquids.

Check the rubber hoses and make sure there are no cuts, holes, wear, leaks etc.

Make sure that the safety guards are correctly positioned and intact. If they are damaged, replace them before attempting to use the machine. If they are not positioned correctly, position them properly.

CAUTION



Do search for oil leakages with your bare hands or other parts of your body; use card or rags to identify the leak. Always wear waterproof gloves and safety goggles.



6.3 - COUPLING THE MULCHING HEAD

DANGER



- When coupling or uncoupling equipment, stand at the side of the machine away from the equipment (at least one metre away).
- Before connecting the quick hitches, the equipment must be connected to the machine mechanically.
- Hydraulic connections must be made with the engine off.

WARNING



- Before making a hydraulic connection between machine and equipment, clean the quick couplings of both units with a cloth; this prevents the hydraulic oil becoming contaminated with foreign matter.
- Firmly tighten the screw-on hydraulic couplings after hitching the equipment.
- Failure to tighten the quick couplings (even partially) can cause the hydraulic motor of the tool to break and / or the oil seal to be ejected.

WARNING



- Read and follow the instructions provided to ensure safe use of the equipment.
- Comply with all instructions provided by the equipment manufacturer.
- Use the safety devices prescribed and make sure that they are in good condition.
- Make sure that the equipment is correctly connected and that it does not come into contact with other parts of the machine when raised.

WARNING



In some cases, changing the equipment can alter the overall centre of gravity and affect the stability of the machine. Contact McConnell for adding special ballast to restore the machine's centre of gravity.

The SlopeTrak 400 is fitted with a lifter on which the flailhead (and other various approved equipment can be attached). To do this, follow the steps below:

1. Start the engine and connect to the radio control.
2. Lower the lifter as far as possible using the right-hand joystick (B).

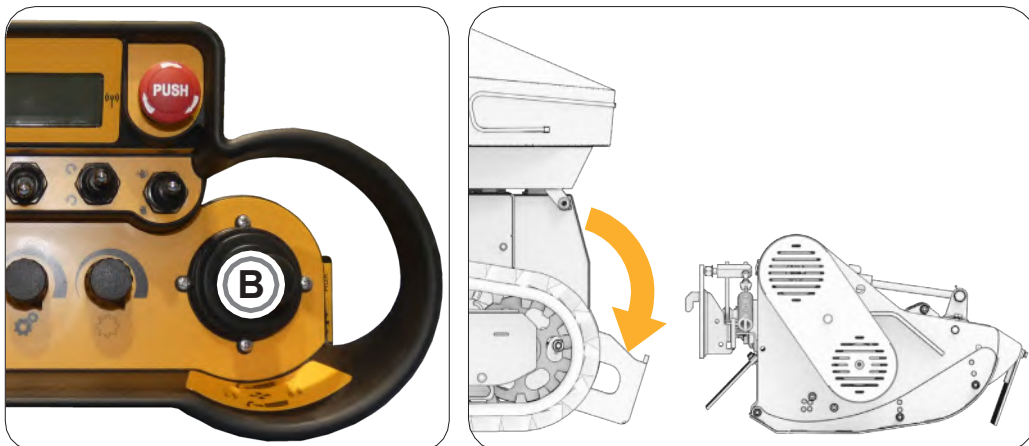

3. Slowly move the machine to position it close to the flailhead coupling plate.

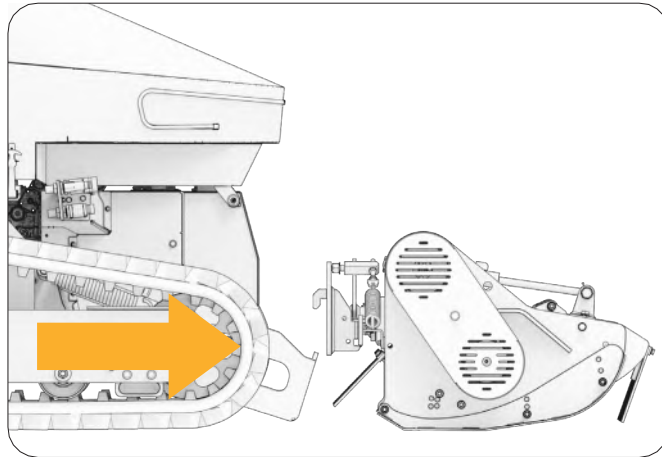

4. Using the right-hand joystick (**B**), raise the lifter to attach the flailhead.
5. Fasten the flailhead to the support on the machine using six M12 x 40 screws; 18mm spanner or wrench will be required.
6. Turn off the engine.

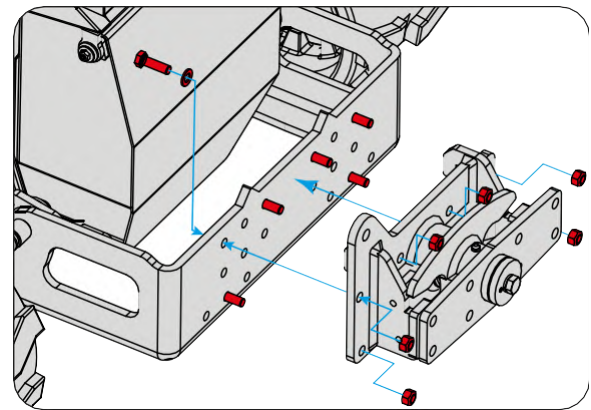
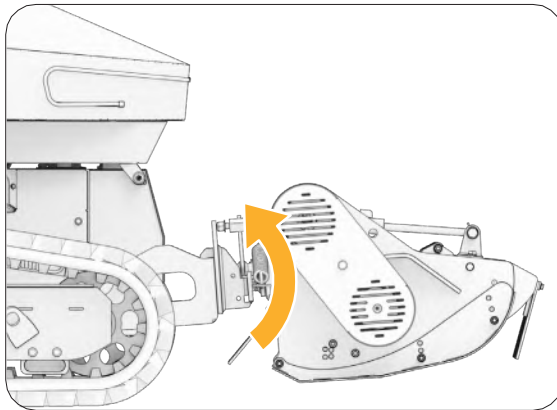

7. Connect the hydraulic power lines of the flailhead to the quick couplings on the right side of the machine, making sure that you clean the couplings before connecting them. The outermost coupling is for the drainage line, while the inner two are for lines (**A**) and (**B**).

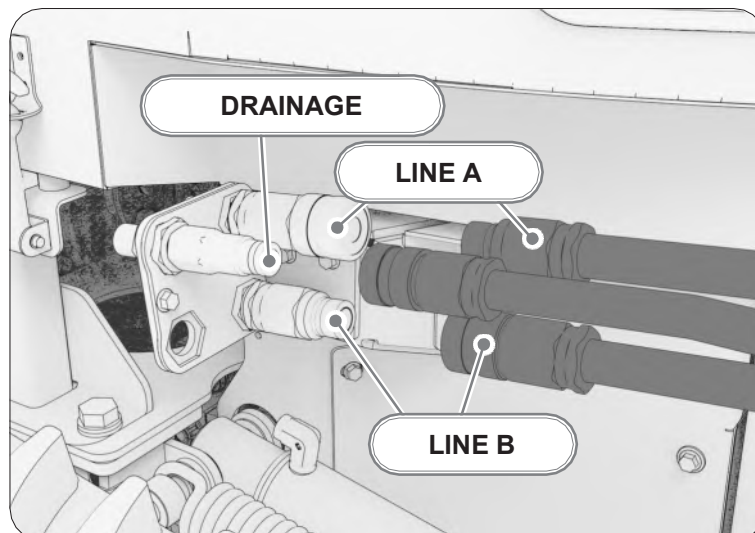

8. Connect the hydraulic services hoses of the flailhead (front hood opening ram) to the quick couplers on the left of the machine, making sure that you clean the couplings before connecting them. The outermost couplings are for the auxiliary function (AUX 1).

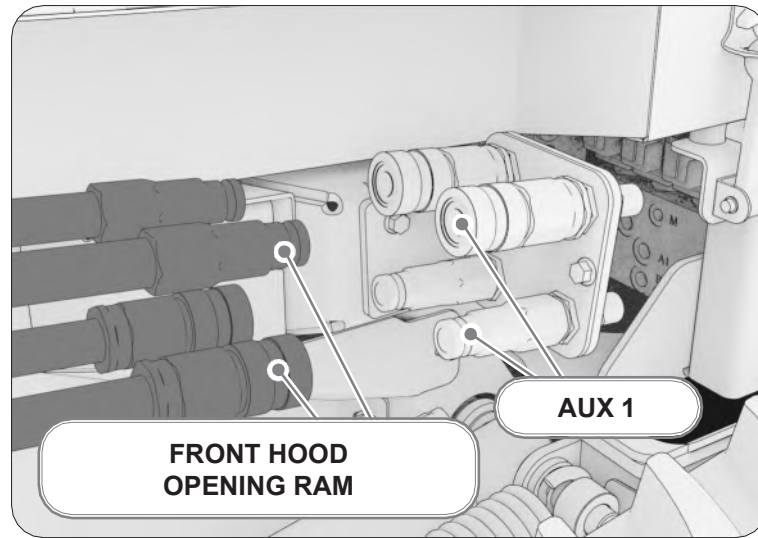

WARNING



- If the flailhead is disconnected from the machine and left without the expansion tank (H), the seal of the hydraulic motor may become damaged.
- McConnel shall not be held responsible for any damage or malfunction due to failure to comply with this warning.
- Connect the expansion tank to the female drainage coupling of the equipment.



6.4 - TRANSMITTER UNIT

DOWNHILL ROTATION OF THE MULCHING HEAD ROTOR

A downhill direction of rotor rotation is recommended for cutting grass and/or shrubs (maximum diameter 3cm). In this direction, the material that is cut or lifted from the ground is ejected towards the back of the machine.

For shredding operations, it is recommended to close the safety guard (front hood), reverse the direction of rotation and to work in reverse (only applicable for rotors fitted with "Y" flails).

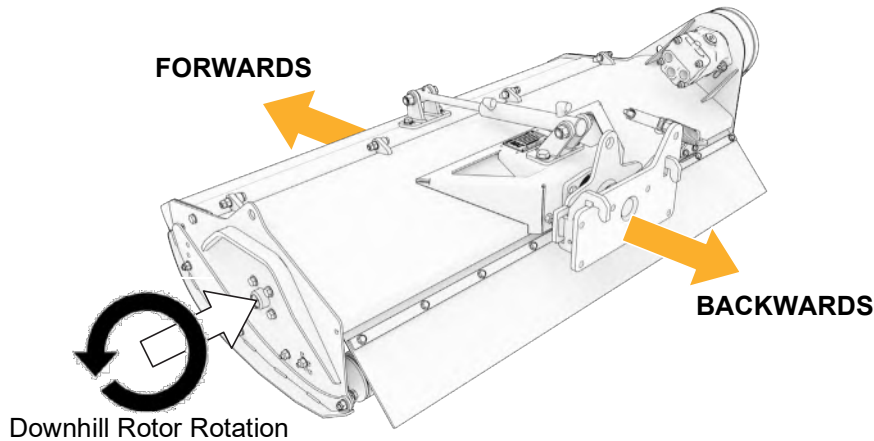

6.4.1 - OPERATING THE TOOL

The equipment's hydraulic motor is activated via switch (5) and controlled by the potentiometer (11). Follow the instructions below to start it.

- Use the switch (5) to activate the hydraulic motor and then select its direction of rotation. To run the equipment, gradually rotate the potentiometer (11) clockwise. When the equipment starts to move, increase the RPM of the hydraulic motor by turning the potentiometer up to 100%.
- At this point, you can increase the speed of the engine to the required working speed by pressing the button (14A).

The correct operating speed of the rotor is **2900 - 3050 rpm**.



6.4.2 - STOPPING THE TOOL

To stop the equipment, proceed as follows:

- Use the button (14B) to decrease the speed of the engine to idle speed.
- Turn the potentiometer (11) anticlockwise to bring it to the minimum.
- Deactivate the equipment's hydraulic motor by moving the switch (5) to the central position.



6.4.3 - OPENING THE SAFETY GUARD (AUX 1)

Auxiliary function (AUX 1) is controlled via the left proportional joystick (A).

- Moving the joystick (A4) to the right closes the head safety guard.
- Moving the joystick (A3) to the left opens the head safety guard.

NOTE: Refer to the operation manual of the equipment connected to the machine for the use of this function.

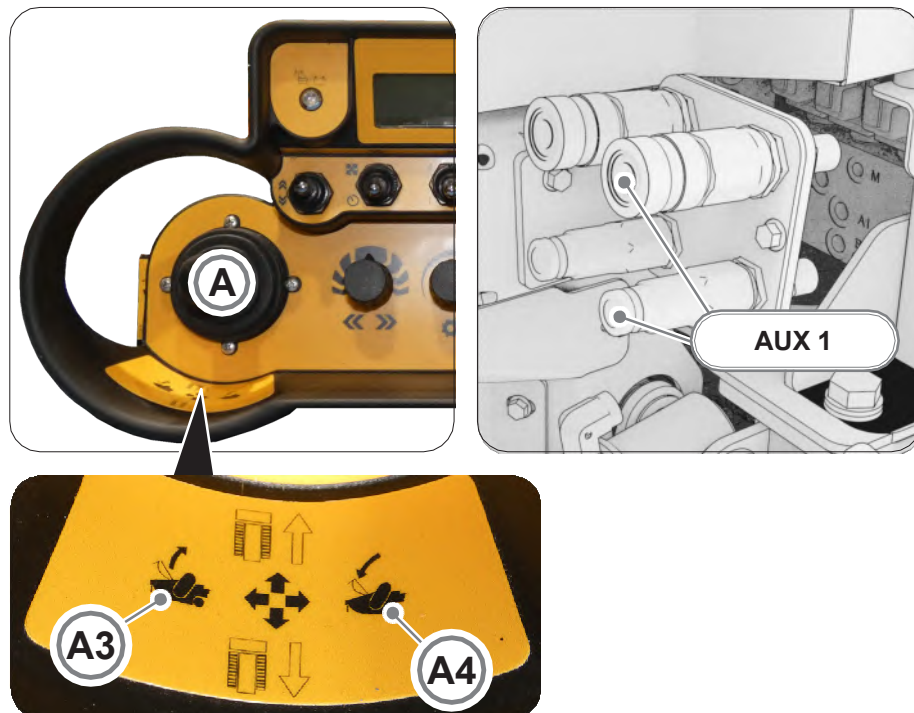

6.4.4 - LIFTER

The lifter is controlled via the right proportional joystick (B).

- Moving the joystick (B1) forwards lowers the lifter.
- Moving the joystick (B2) backwards raises the lifter.



CAUTION

FLOATING FUNCTION



Lower the lifting device so that the tool is resting on the ground. Extend the cylinder rod of the lifter until the pin reaches the centre of the slot. In this position, the tool will follow the contour of the ground more accurately.

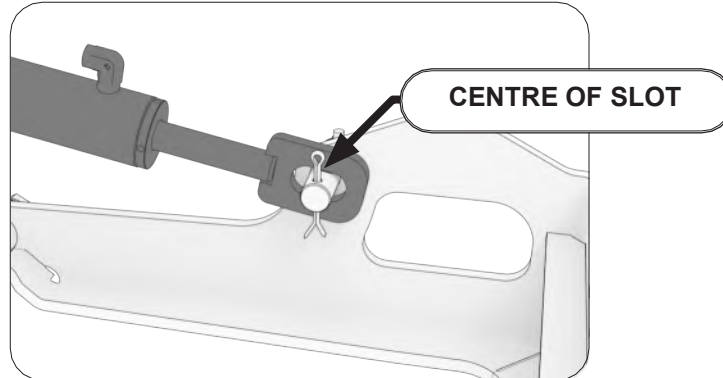

WARNING



- It is recommended not to adjust the lifter when the equipment is in operation to prevent cutting residues from being thrown long distances.
- It is recommended not to adjust the lifter if you are on a slope with the front of the machine facing uphill.

6.5 - ADJUSTING THE CUTTING HEIGHT

The cutting height refers to the distance between the ground and the rotor. It can be regulated by adjusting the support roller or the runners.

WARNING



Adjust the cutting height with the machine OFF and rotor stationary.

ADJUSTING THE RUNNER HEIGHT

To adjust the height of the runners, proceed as follows:

1. Rest the mulching head on the ground and make sure that it can't move.
2. Disconnect the mulching head from the machine.
3. Lift the mulching head using ropes or chains (ensure that they have an adequate lifting capacity) at the lifting points and secure it to a hoist, a bridge crane or a crane.
4. Unscrew the two M10 screws (A) (two on each side) that fasten the runner, using two 16mm wrenches.
5. Adjust the runner to the required position by using one of the three adjustment holes.
6. Refit and tighten the screws (A); torque screws to **67 Nm**.
7. Make sure that the flails do not touch the ground.
8. Rest the mulching head on the ground and make sure that it can't move.
9. Reconnect the mulching head to the machine.

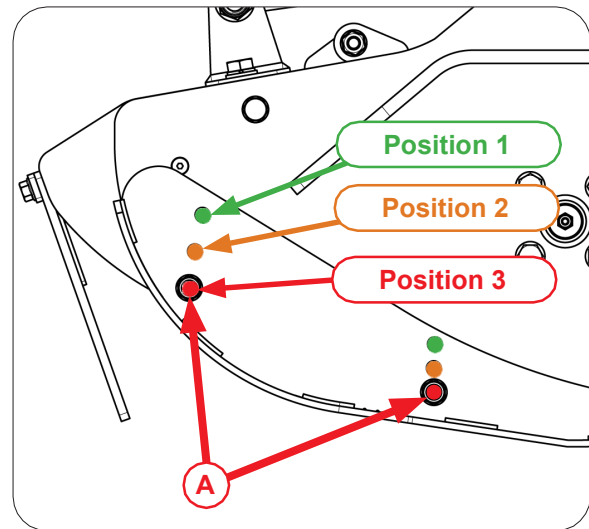

Rotor	Cutting height	
	"Y" flails	Hammers
Position 1	20 mm	22 mm
Position 2	33 mm	35 mm
Position 3	46 mm	48 mm

ADJUSTING THE SUPPORT ROLLER HEIGHT

To adjust the height of the rear roller, proceed as follows:

1. Rest the mulching head on the ground and make sure that it can't move.
2. Disconnect the mulching head from the machine.
3. Lift the mulching head using ropes or chains (ensure that they have an adequate lifting capacity) at the lifting points and secure it to a hoist, a bridge crane or a crane.
4. Loosen the M10 screws (A) using two 16mm wrenches. Carry out the same procedure on the other side.
5. Unscrew the M10 screw (B) that secures the support roller using two 16mm wrenches. Carry out the same procedure on the other side.
6. Adjust the support roller to the required position using one of the five adjustment holes.
7. Screw and tighten the screws (B); torque screws to **67 Nm**.
8. Tighten the screws (A); torque to **67 Nm**.
9. Make sure that the flails do not touch the ground.
10. Rest the mulching head on the ground and make sure that it can't move.
11. Reconnect the mulching head to the machine.

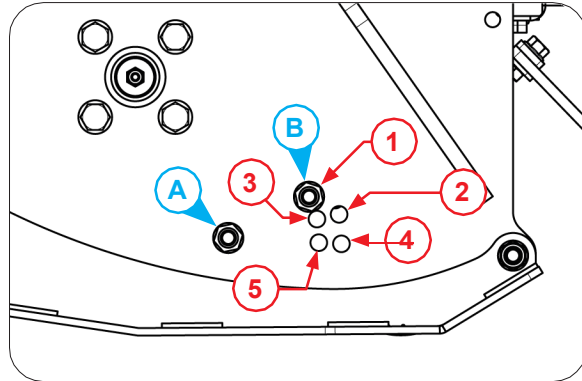

Rotor	Cutting height	
	"Y" flails	Hammers
Position 1	20 mm	22 mm
Position 2	35 mm	37 mm
Position 3	49 mm	51 mm
Position 4	63 mm	65 mm
Position 5	75 mm	77 mm

6.6 - ADJUSTING THE END STOPS

Two end-of-stroke pins (A) are positioned on the equipment to prevent rotations caused by accidental impacts.

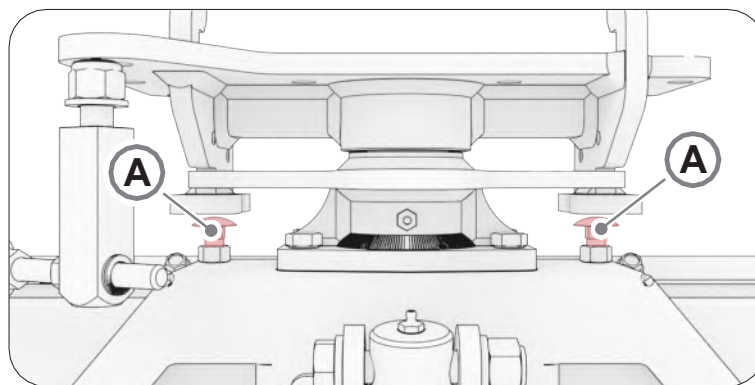

WARNING



The screws must always touch the support to avoid breaking the central pin.

6.7 - FAULTS, CAUSES AND SOLUTIONS

Malfunction	Cause	Solution
Unusual noises coming from the mulching head.	Insufficient lubrication of rotor bearings.	Grease the marked points.
	Foreign bodies wrapped around the rotor.	Stop the rotor and remove the foreign body.
	Transmission unit working incorrectly.	Check the tension of the belt and that it is aligned correctly.
Excessive vibration.	Excessive and/or irregular flail wear.	Replace the flails.
	Worn or broken flails.	Replace the flails.
	Foreign bodies wrapped around the rotor.	Stop the rotor and remove the foreign body.
Irregular cutting.	Worn or broken flails.	Replace the flails.
	Flail and/or cutting tool jammed.	Stop the rotor and check all the tools. Find out why it is blocked (material jammed, screws seized etc.). Release the tool.
Rapid flail wear.	Flails touching the ground.	Adjust the cutting height by adjusting the supports.
Premature belt breakage.	If the tension is too high or too low, it can damage the belt and cause it to break prematurely.	Make sure that the tension of the belt is correct and ensure pulleys are correctly aligned.
Rotor not working.	Belt broken or damaged. Hydraulic motor broken or damaged.	Check the belt (replace if damaged). Check the hydraulic motor.
The rotor continues to rotate when the rotor control is not activated.	Pump is not zeroed correctly.	Check the zero of the pump and reset it. Contact McConnel
Whistling noise coming from the transmission belt zone.	Belt tension too low.	Check the belt tension.

NOTE: If the fault or the reason for it is not indicated in the list of faults shown in tables, contact McConnel in order for repairs to be carried out.

7 - TRANSPORT AND HANDLING

7.1 - LIFTING

Pay maximum attention to safety during loading and unloading operations, which must be performed by personnel qualified to use the corresponding equipment (slings, forklifts, cranes etc.).

The specific lifting points indicated below must be used when lifting the head. Make sure that you use suitable lifting chains or wire ropes.

When transporting the head, a vehicle of appropriate power and size must be used.

The head must be placed on a flat surface and anchored down with cables. Its stability should be checked when it is in position.

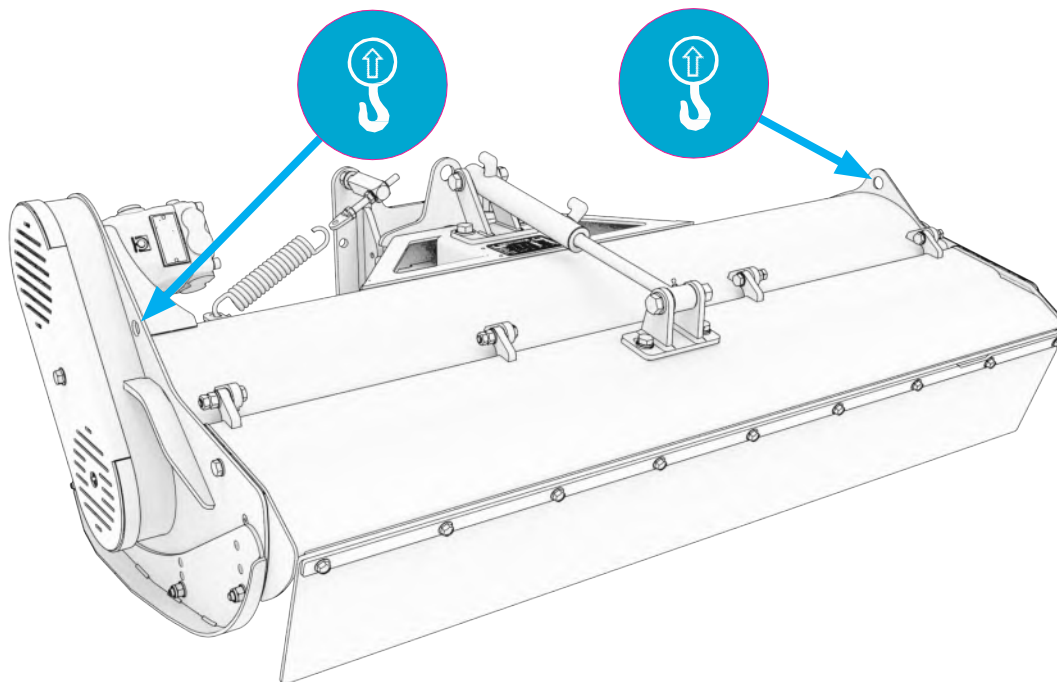

It should be noted that when using wire ropes, slings or chains to lift the machine, you must comply with the diagram below that indicates the minimum lifting angles.

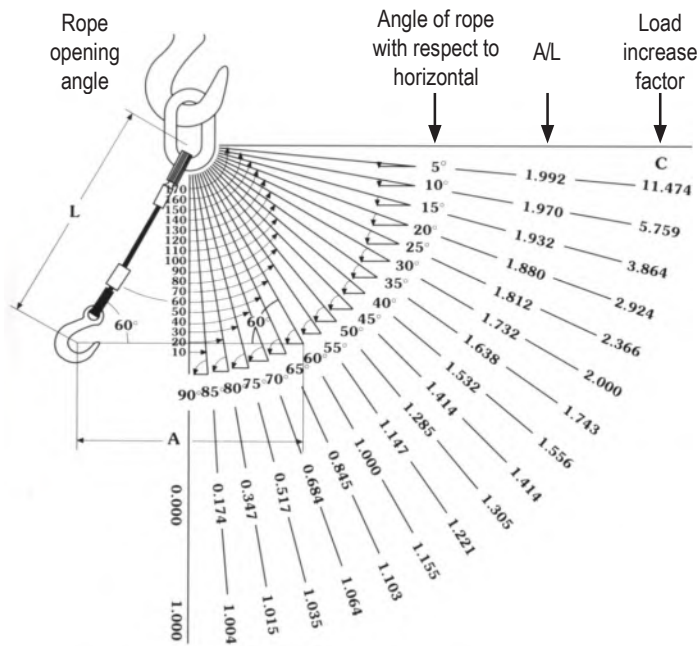

Angle at top	Load increase factor
0°	1
10°	1,004
20°	1,015
30°	1,035
40°	1,064
50°	1,103
60°	1,155
70°	1,221
80°	1,305
90°	1,414
100°	1,556
110°	1,743
120°	2,000
130°	2,336
140°	2,924
150°	3,864
160°	5,759
170°	11,474

WARNING



Do not attach wire ropes or slings to the roll bar in order to lift the machine. This component is not designed for lifting the machine.

8 - STORAGE

If the machine is to be unused for a long time, it should be stored in an area sheltered from the elements to protect it from damage. Before storing the machine, it is recommended that you clean it thoroughly and lubricate all mechanical components to protect them from rust. The machine should be stored at a temperature between 0 °C and 40 °C.

Before storing the machine for long periods, it is recommended that you prepare it as follows:

- Free the rotor and tools from any cutting residues.
- Clean the machine carefully.
- Visually inspect the entire machine to identify any structural damage or deep scratches on the paintwork. Make sure that the original safety signs are still present in their proper positions and that they are undamaged and legible.
- Check the front and rear guards and their connections for any damage.
- Grease all mechanical parts that are subject to friction, the locking pins and all machine parts that are no longer covered with their original coating of paint in order to prevent rust from forming;
- Connect the expansion tank (A) supplied with the machine to the discharge tube.
- Store the machine on a flat surface, in a covered location where possible, checking its stability once it is in position.

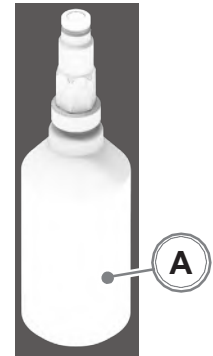

CAUTION



- **If the equipment is disconnected without the expansion tank, the hydraulic motor seal may become damaged.**
- **McConnel shall not be held responsible for any damage or malfunction due to failure to comply with this warning.**

8.1 - BEFORE USE OR PUTTING BACK INTO SERVICE AFTER A LONG PERIOD OF INACTIVITY

Before using the machine for the first time, or after a long period of inactivity, the following steps must be performed:

- Check that the machine has not been damaged.
- Check the mechanical components, which must be in good condition and not rusty.
- Check the flails for wear.
- Thoroughly grease all moving parts.
- Check that there are no oil leaks in the piping or unions.
- Check that all guards are correctly positioned.

8.2 - DISMANTLING AND DECOMMISSIONING

- Should you decide to no longer use the machine or part of it, it must be dismantled and decommissioned.
- Before scrapping, the plastic/rubber parts and electrical and electronic materials must be separated.
- Drain any used fluids and dispose of them in a dump/recycling facility equipped to handle this product.
- Carry out these operations according to the regulations in force.

WARNING



If the machine or parts of it are decommissioned, all parts that could constitute a hazard must be made safe.

WARNING



Remember that every time you change the oil, rubber hoses and any other parts of the machine that should be disposed of separately, you should always refer to current legislation regarding waste disposal. Take used hydraulic fluid to a dump/recycling facility equipped to handle this product.

9 - MAINTENANCE

WARNING



- When coupling/uncoupling the machine, take particular care when accessing the work area between the machine and the equipment. The operation should only be performed by trained personnel.
- Make sure, before starting the machine that people and/or animals are at a sufficiently safe distance from the machinery.



9.1 - INTRODUCTION

To obtain best performance from the machine and ensure maximum durability of all its components, the instructions for use and maintenance must be followed carefully by machine operators.

Therefore, we recommend our customers to carefully read these instructions and consult the manual any time they need advice on how to eliminate possible inconveniences. Because the machine usually operates in contact with water, sand, earth, etc., regular lubrication is necessary. This is of vital importance not only to ensure the long life of the machine, but also to keep running costs low.

For further information, please contact our service centre:

Contact the McConnel Technical Assistance Service:

Telephone +44 (0)1584 873131
Email sales@twose.com

9.2 - GENERAL INSTRUCTIONS

- Before carrying out any maintenance or inspecting and/or checking the equipment, turn off the machine's engine and remove the ignition key from the machine.
- When removing or reinstalling parts of the equipment, always use suitable extractors, spanners and equipment that will not damage the components.
To release parts that are solidly adherent, use copper or wooden hammers.
- Separate the pieces of the various units and partially screw the nuts onto their corresponding pins or stud bolts. Clean the parts using brushes or rags, then wash them using paraffin or warm water and remove all residues using compressed air.
- After grinding or finishing using abrasive tools, thoroughly clean the parts, making sure that all the abrasive dust has been removed.
- When re-assembling the pieces, make sure that they are clean and then lubricate appropriately.
- Pay great attention to the safety rings and cotter pins. Replace them immediately if there are signs of damage.
- Maintenance of the equipment must be carried out by authorised personnel.

9.3 - EXTRAORDINARY MAINTENANCE

These are repairs or replacements of one or more components of the machine, which only usually become necessary after years of good operation and which do not alter the characteristics of the machine. In the case of substantial modifications, the manufacturer cannot be considered liable for any risks that could arise. These interventions must be performed by authorised personnel.

9.4 - LUBRICANTS AND FLUIDS TABLE

9.4.1 - GREASES TABLE

COMPONENT	RECOMMENDED LUBRICANT	INTERNATIONAL STANDARDS
HYDRAULIC SYSTEM Mineral oil	ISO 46 Q8 HELLER 46	DIN 51 524, 2-HLP DIN 51 524, 3-HLP API CD, CE, CF
HYDRAULIC SYSTEM Biodegradable oil	PANOLIN BIO HLP SYNTH E	FZG Test A/8.3/90 stage 12 ISO 15380 HEES
	Q8 HOLBEIN HP SE Bio 46	ISO 11158 Category HV Din 51524, Part 3 Category HVLP ISO 15380 / CEC-L33-A-93 - Water Hazard Class (VwVwS) WGK 1 - Category HEES
PINS, BUSHES AND SLEW RINGS	MOLY GREASE EP NLGI2 or NLGI3EP GREASE	Black lithium soap grease with Molybdenum Disulphide. For automatic greasing the use of added CONTACT GREASE NLGI2 with purple lithium soap is recommended.
BEARINGS	PAKELO GREENPLEX EP NLGI 2 GREASE	EP ADHESIVE Grease, Aluminium complex soap

9.5 - DAILY MAINTENANCE

Carry out the following operations systematically at the beginning of each working day:

- Check for any loose screws and nuts and tighten if necessary.
- Check the condition of the safety guards and replace if damaged or worn.
- Check the condition of the hydraulic pipes, replace if damaged or worn.

9.5.1 - CLEANING THE MACHINE

Clean the machine at the end of each working day using pressurised water; removing any cutting residues, earth, dust etc. paying particular attention to flammable materials.

9.6 - TRANSMISSION MAINTENANCE

9.6.1 - BELT TENSIONING

CAUTION



- Check the tensioning of the belts after the *first 4 hours* of operation for a new machine and each time the belts are replaced.
- The tension of the belts should be checked *every week* or *every 40 hours*.

WARNING



Make sure that you tension the belt correctly. If the tension is too high or too low, it may cause the belt to break suddenly and prematurely.

Perform the following operations to adjust the tension of the belts:

- Loosen the two M10 nuts (**A**) using a 16mm wrench.

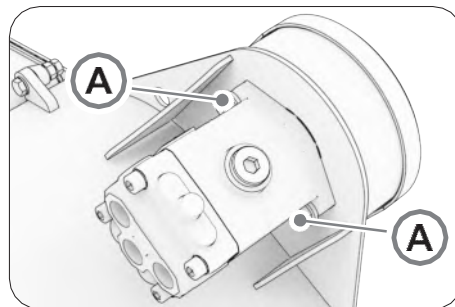

- Remove the belt guard (**B**) by unscrewing the M10 screw (**C**) using a 15mm wrench.
- Loosen the two M10 nuts (**D**) using a 15mm wrench.
- To tension the belt, unscrew the M10 screw (**E**) using a 16mm wrench until the correct tension is obtained.

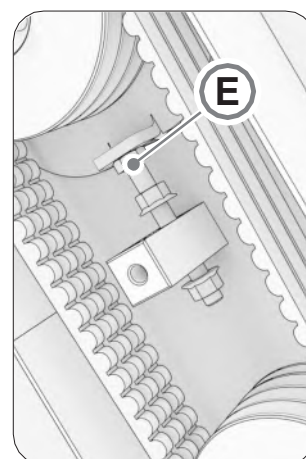
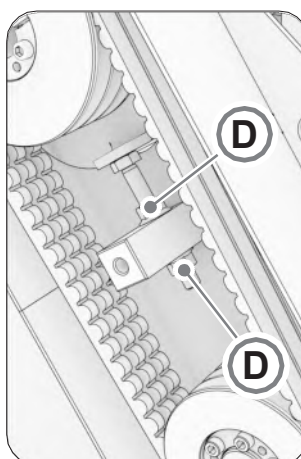
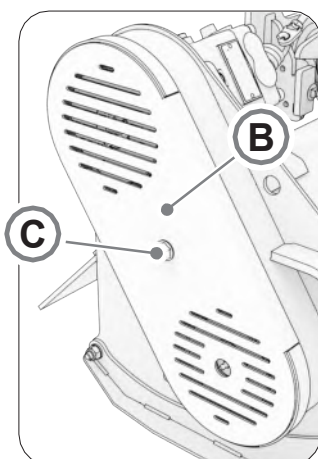

- Use a frequency meter (McConnel approved) to measure the tension of the belt. **The frequency should be 92 Hz when the belt is tensioned correctly.** If a frequency meter is not available, press the middle of the belt down with a force of **200 N**. The maximum deflection of a correctly tensioned belt is **8mm**.

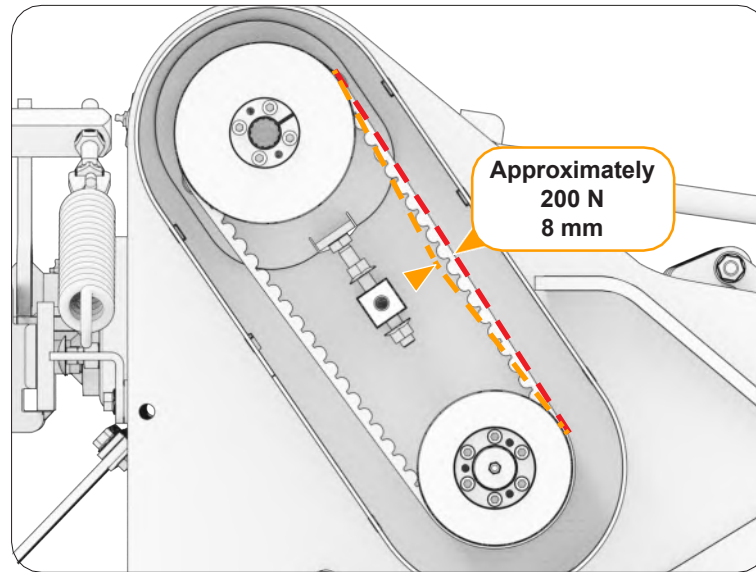

- Once the belt has been tensioned correctly, tighten the two M10 nuts (**D**) with a torque of **46 Nm** using a 15mm wrench.
- Tighten the two M10 nuts (**A**) with a torque of **46 Nm**, using a 16 mm wrench.
- Secure the guard (**B**) by tightening the screw (**C**) with a torque of **46 Nm**.

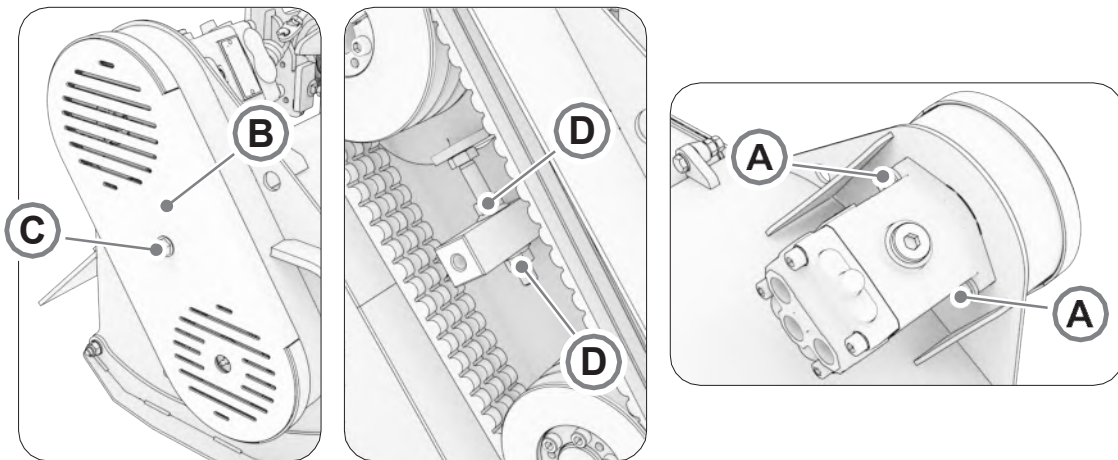

For tightening torques, refer to section 11 of this manual.

9.6.2 - REPLACING THE BELTS

CAUTION



- Check the tensioning of the belts after the *first 4 hours* of operation for a new machine and each time the belts are replaced.
- The tension of the belts should be checked *every week* or *every 40 hours*.

WARNING



Make sure that you tension the belt correctly. If the tension is too high or too low, it may cause the belt to break suddenly and prematurely.

To replace the belts, follow the procedure below:

- Loosen the two M10 nuts (**A**) using a 16mm wrench.

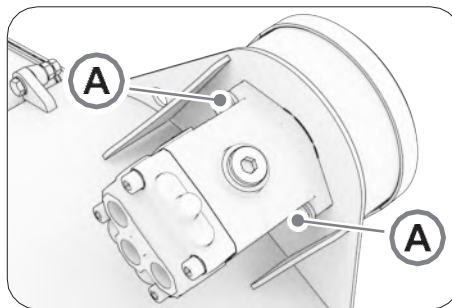

- Remove the belt guard (**B**) by unscrewing the M10 screw (**C**) using a 15mm wrench.
- Loosen the two M10 nuts (**D**) using a 15mm wrench.
- Tighten the M10 screw (**E**) using a 16mm wrench until the three belts (**F**) can be removed.

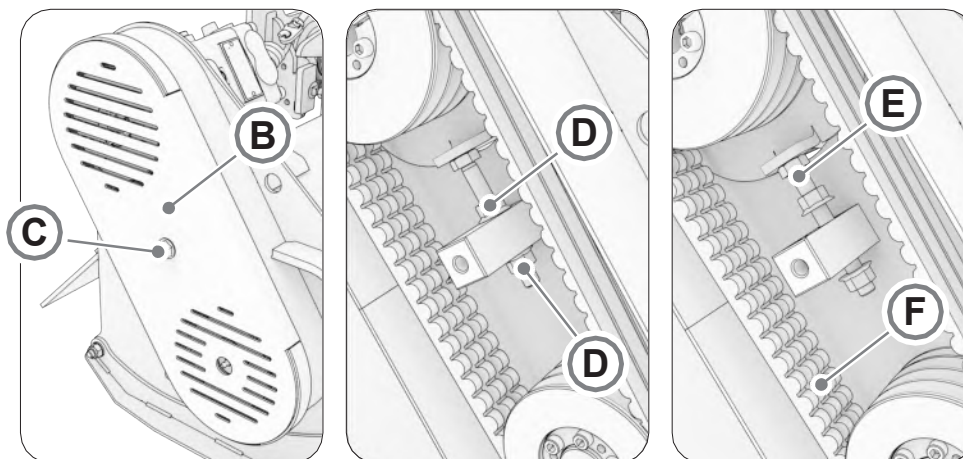

- Replace the three belts (**F**) with new ones.
- Tension the belt following the procedure in the previous section. Once the belt has been tensioned correctly, follow the above procedure in reverse.

For tightening torques, refer to section 11 of this manual.

9.7 - ROTOR MAINTENANCE

9.7.1 - REPLACING THE ROTOR

WARNING



- Make sure that you have placed the mulching head on a flat surface and made it safe.
- You must sling the rotor to prevent it from falling suddenly and to make its subsequent removal easier.

DANGER



- Use appropriate PPE and protective clothing for the work to be carried out.
- Do not start any maintenance operation with the machine or any of its parts in movement.
- Make sure that the keys have been removed from the ignition panel of the machine.

- Unscrew the two screws (A) on the sides of the mulching head.
- Open the safety guard (B).
- Loosen the two M10 nuts (C) using a 16mm wrench.

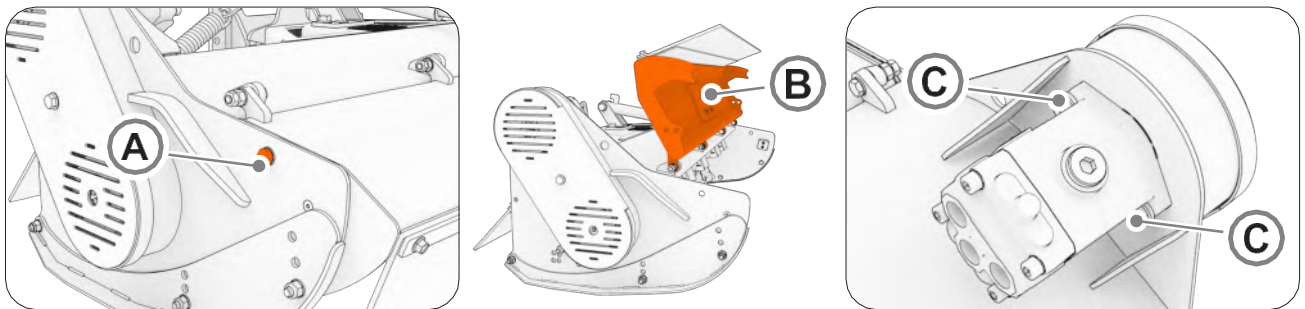

- Remove the belt guard (D) by unscrewing the M10 screw (E) using a 15mm wrench.
- Loosen the two M10 nuts (F) using a 15mm wrench.
- Tighten the M10 screw (G) using a 16mm wrench until the three belts (H) can be removed.

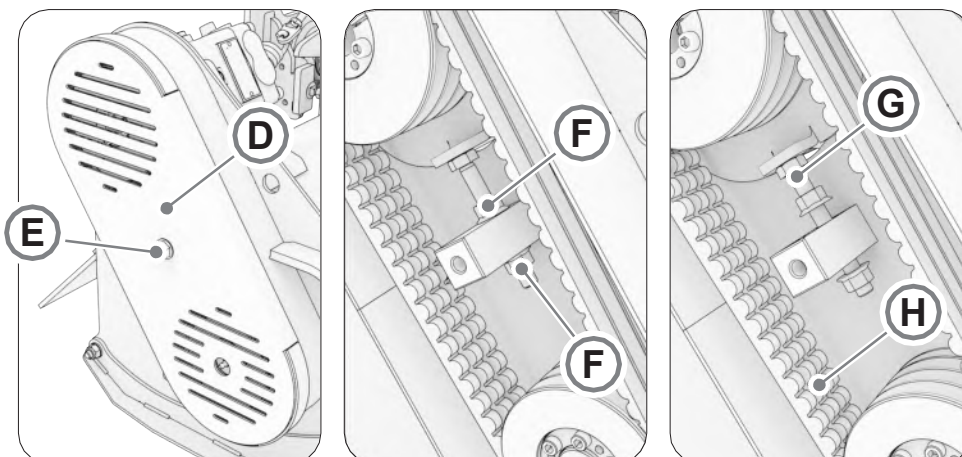

- Unscrew the six M6 screws (I) using a 5mm hex wrench until the taper bush (J) can be removed.
- Remove the pulley (K).

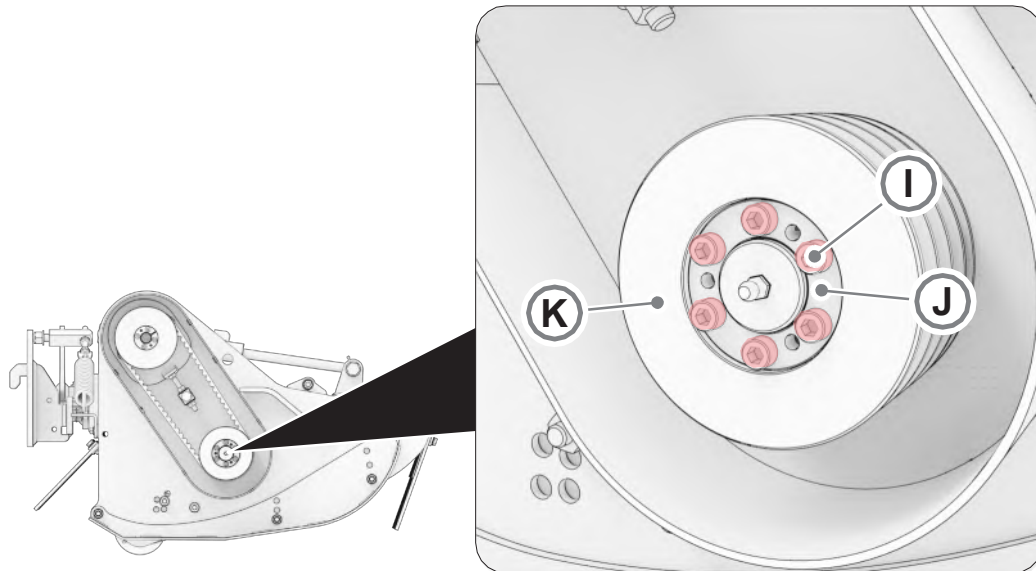

DANGER



At the next step, the rotor is disconnected from the frame of the head. You must therefore sling the rotor and keep it raised in a safe position to prevent it from falling accidentally causing injury or damage to persons or property.

- Unscrew the four M10 screws (L) using a 15mm wrench.
- Remove the flange (M).
- Remove the oil seal (N).
- Loosen the four M10 screws (O) on the opposite side using a 15mm wrench.

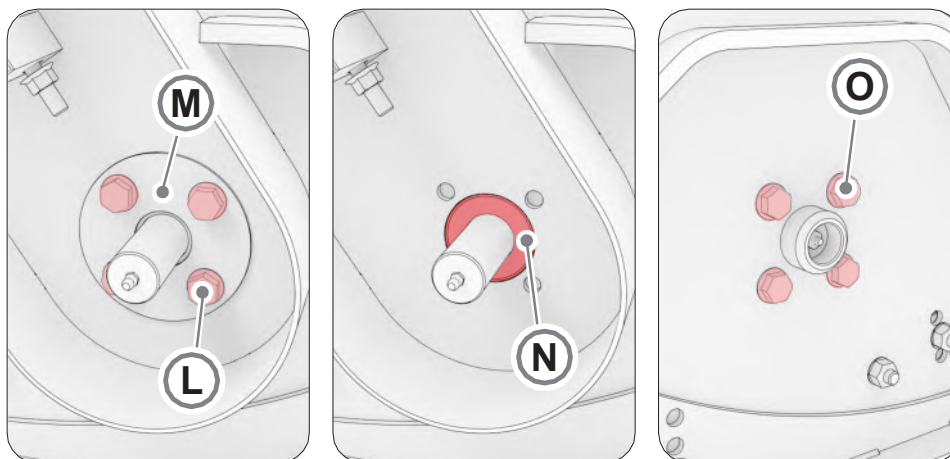

- Move the rotor towards the right hand side of the head (transmission side) (**P**).
- Tilt the rotor (**Q**) sufficient to permit removal.

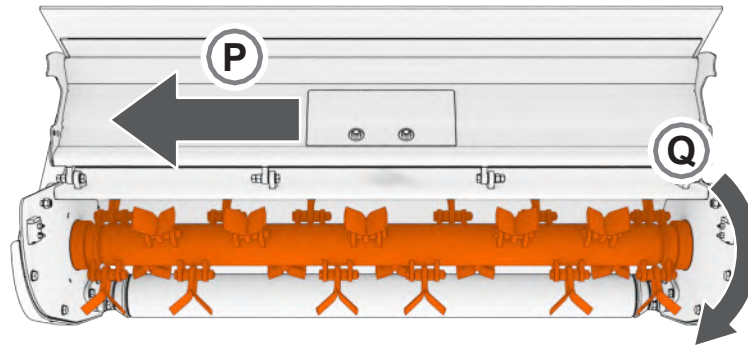

On the right side of the rotor (transmission side, longer pin):

- Remove the Seeger ring (**R**).
- Remove the bearing support (**S**) using a bearing puller.

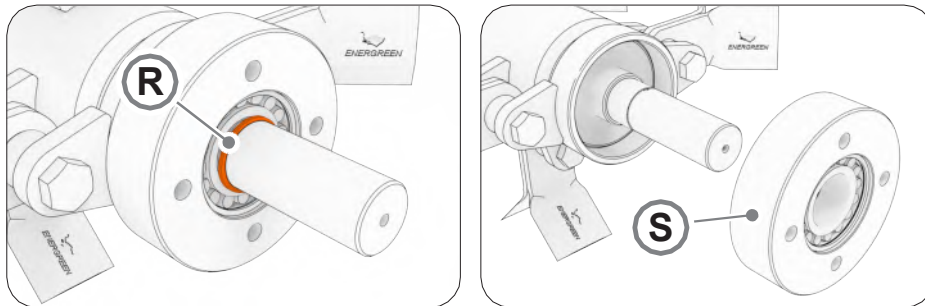

- On the left side of the rotor (shorter pin), remove the bearing support (**T**) using a bearing puller.

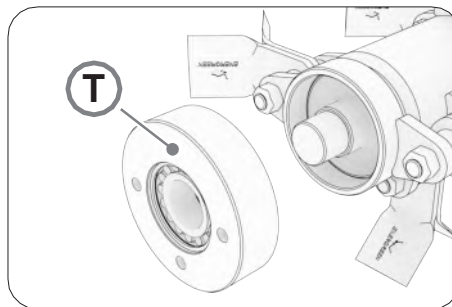

- Replace the rotor.
- Reinstall the bearing supports (**T**) and (**S**); then lock the bearing support (**S**) in place using the Seeger ring (**R**).
- Put the rotor back into the frame of the head and then secure it in place by tightening the screws (**O**) with a torque of **67 Nm**.
- Insert the new oil seal (**N**).
- Insert the flange (**M**) and then secure it by tightening the screws (**L**) with a torque of **67 Nm**.
- Install pulley (**K**).
- Insert the taper bush (**J**) into the pulley (**K**).

- Align the lower pulley (**K**) with the upper pulley (**U**), using a metal plate or a right angle ruler (**V**).

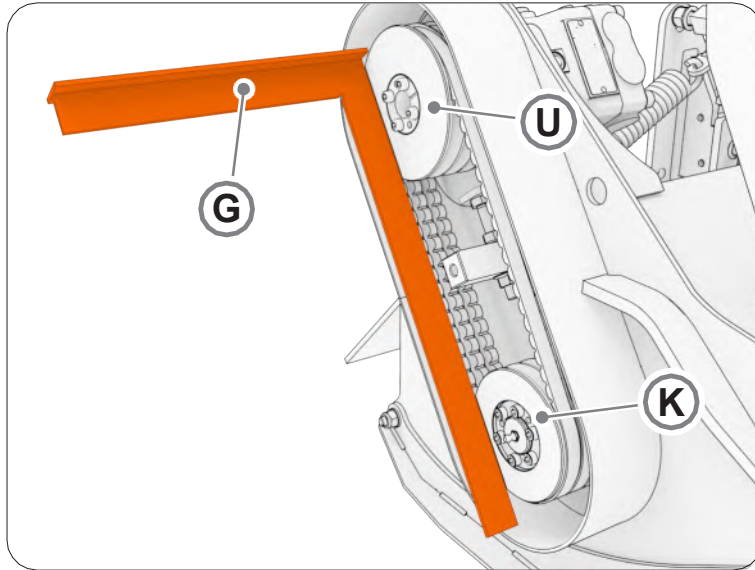

- Once the pulley (**K**) has been aligned, use a 5mm hex wrench to tighten the six M6 screws with a torque of **17 Nm** to secure the taper bush (**J**) in position.
- Install the three belts (**H**).
- Tension the belts as described in section 9.6.1.

CAUTION



- If you notice any unusual vibrations or noises coming from the head, stop the rotor immediately and check for any missing or damaged flails or damage to the rotor.
- **CONTINUING TO USE THE ROTOR WITH DAMAGED PARTS CAN CAUSE THE MACHINE TO MALFUNCTION AND BREAK DOWN.**

9.7.2 - REPLACING THE ROTOR SUPPORT BEARINGS

DANGER



- Use appropriate PPE and protective clothing for the work to be carried out.
- Do not start any maintenance operation with the machine or any parts moving.
- Ensure that the keys have been removed from the ignition panel of the machine.

WARNING



- Always use original spare parts for repairs and maintenance.
- McConnell shall not be held liable for any damage as a result of failure to follow the above instructions.
- The machine is guaranteed according to the contractual agreements specified at the time of sale.
- The warranty will lapse whenever the regulations and instructions laid out in this manual are not correctly followed.

If one of the rotor support bearings becomes damaged, the rotor has to be removed in order to replace it; refer to previous section on rotor removal.

RIGHT SIDE (TRANSMISSION SIDE)

- Remove the Seeger ring (A).
- Remove the bearing support (B) using a bearing puller.
- Remove the bush (C).
- Remove the Seeger ring (D).
- Remove the oil seal (E) and the shim washer (F).
- Remove the bearing (G) and replace it.
- Reinstall everything following the instructions in reverse.

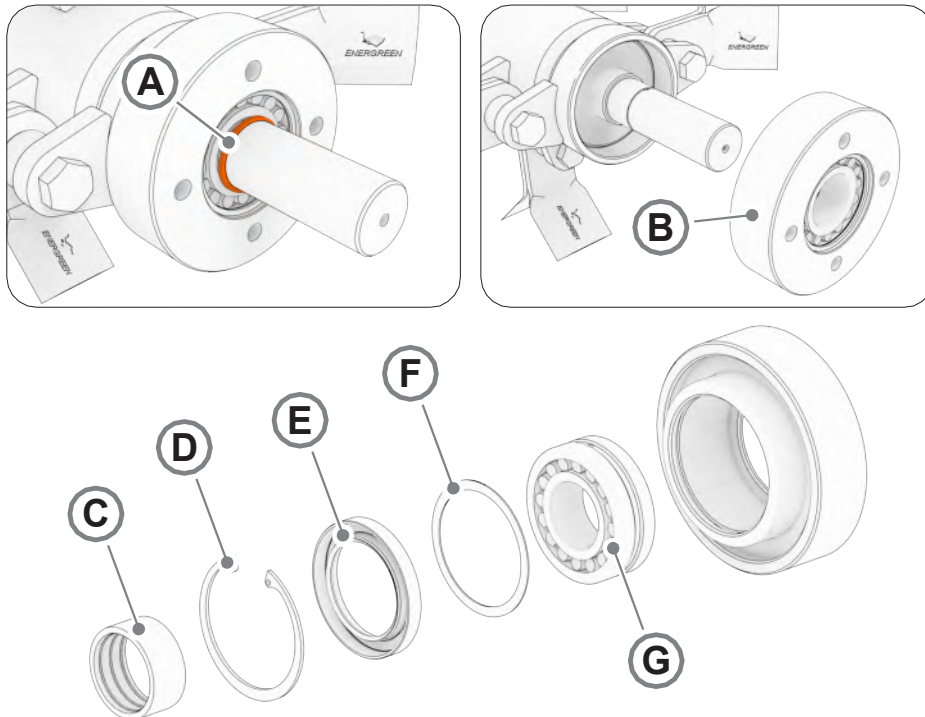

LEFT SIDE

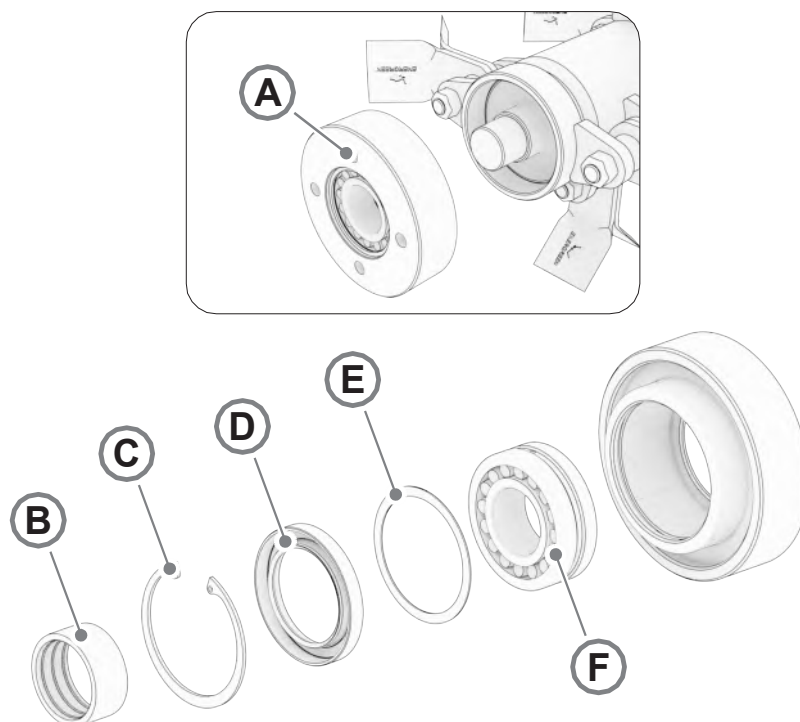

- Remove the bearing support (A) using a bearing puller.
- Remove the bush (B).
- Remove the Seeger ring (C).
- Remove the oil seal (D) and the shim washer (E).
- Remove the bearing (F) and replace it.
- Reinstall everything following the instructions in reverse.

9.7.3 - CHECK THE CUTTING FLAILS

CAUTION



- The flails should be checked *every 8 hours or every day*.
- If you notice any unusual vibrations or noises coming from the head, stop the rotor immediately and check for any missing or damaged flails or damage to the rotor.
- **CONTINUING TO USE THE ROTOR WITH DAMAGED PARTS CAN CAUSE THE MACHINE TO MALFUNCTION AND BREAK DOWN.**

Replace the flails immediately when you notice:

- broken flails
- excessive bolt wear
- excessive flail wear
- excessive vibration coming from the head.

9.7.4 - REPLACING THE CUTTING TOOLS

DANGER



- Use appropriate PPE and protective clothing for the work to be carried out.
- Do not start any maintenance operation with the machine or any parts moving.
- Ensure that the keys have been removed from the ignition panel of the machine.

- To replace the flails use two 18mm wrenches.
- Unscrew the M12 screw (A) and the nut (B).
- Remove and replace the bushings (C) and the flails (D).
- Tighten the new screw and the new nut with a tightening torque of **135 Nm**.

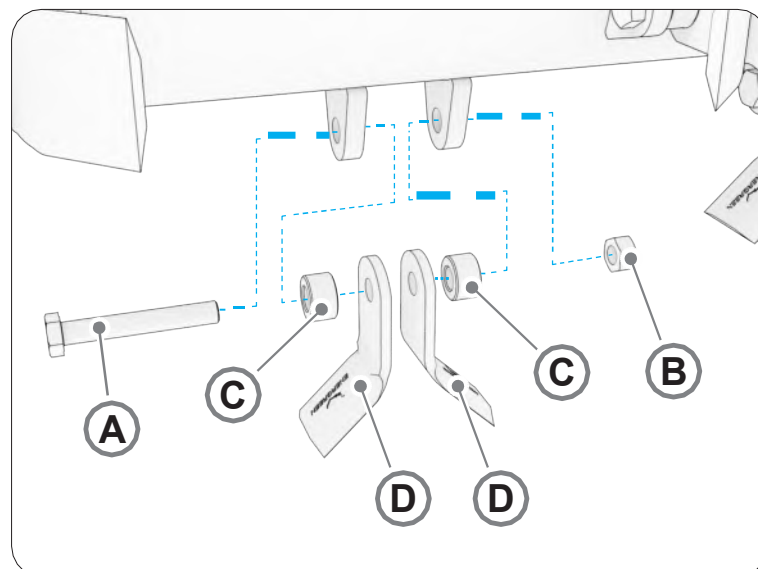

9.8 - SUPPORT ROLLER MAINTENANCE

DANGER



Before the support roller is disconnected from the frame of the head you must 'sling' the roller and keep it raised in a safe position to prevent it from falling accidentally causing injury or damage to persons or property.

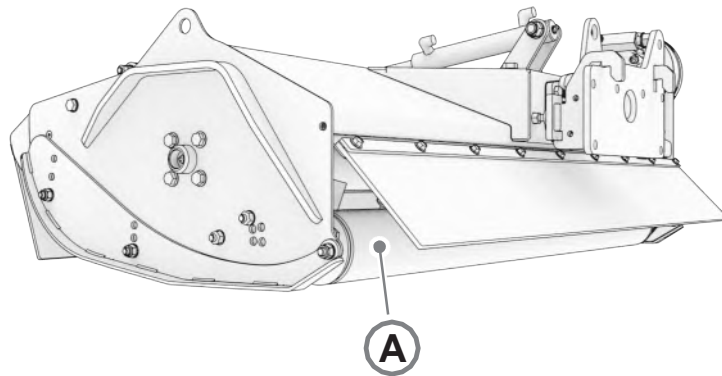

The rear roller (A) supports the mulching head on the ground.

The roller and/or bearings may become damaged if the user is not careful. Immediately repair any fault you notice to prevent further damage.

To replace the bearings:

- Remove the roller from the head by loosening two nuts (B) and the M10 screws (C) using two 16mm wrenches. Do this for the other side as well.

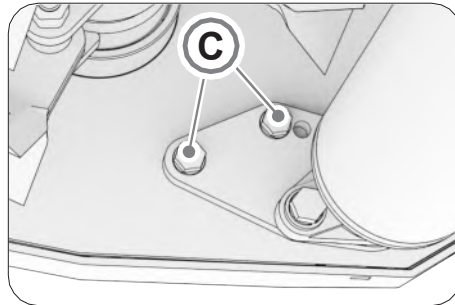
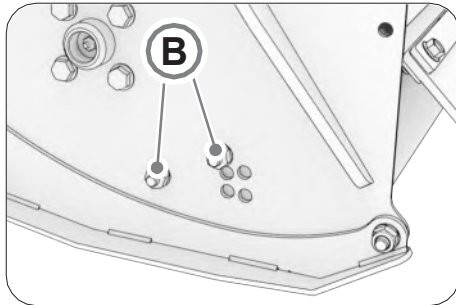

- Remove the four screws (D) (on both sides) using an 18mm wrench.
- Remove the two Seeger rings (E) (on both sides), remove and replace the bearing support (F).
- Reinstall the Seeger rings (E).
- Screw the four screws (D) back on and tighten with a torque of **116 Nm**.
- Reinstall the roller, tightening the four screws (C) with a torque of **67 Nm**.

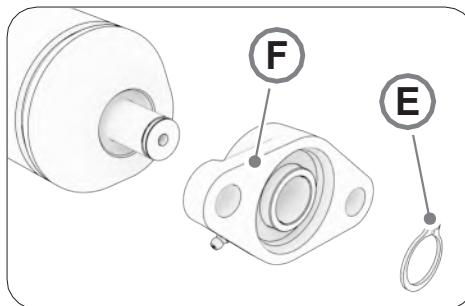
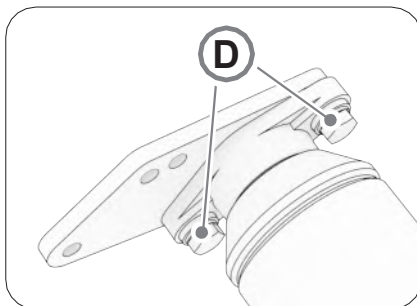

9.9 - GUARD MAINTENANCE

9.9.1 - REPLACING THE RUBBER FLAPS

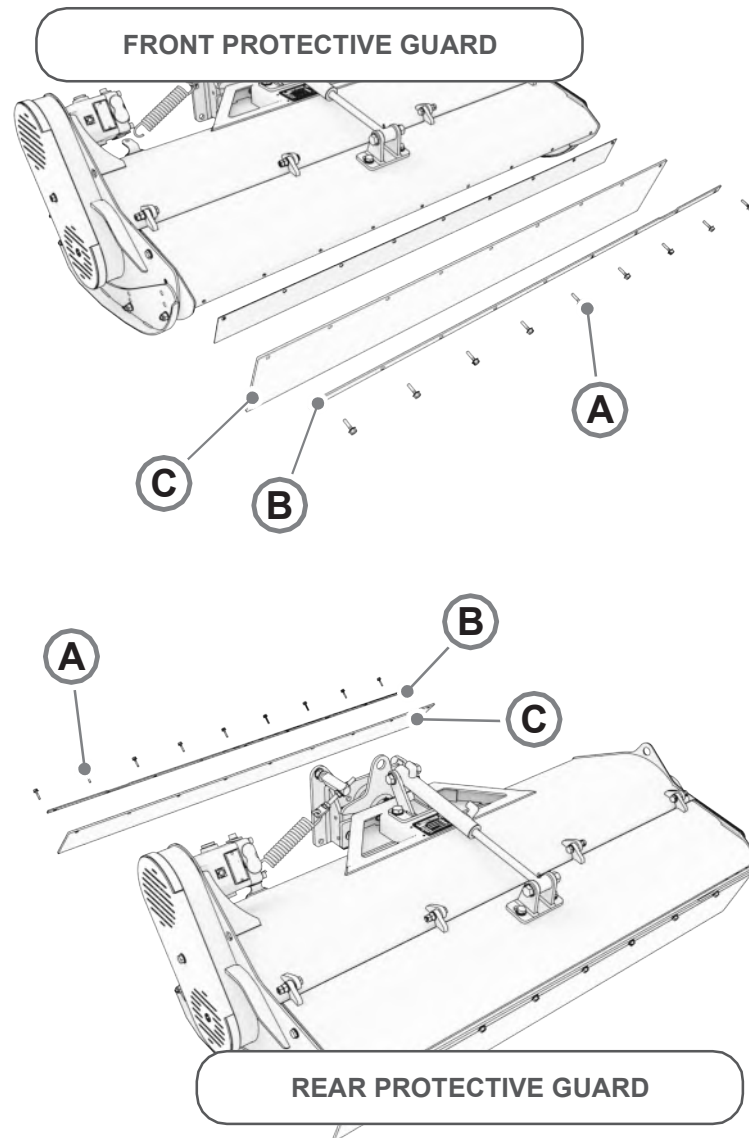

If one or both of the rubber flaps (C) requires replacing, the procedure is as follows:

- Unscrew the M8 screws (A) from the frame using a 13mm wrench.
- Remove the rubber flap (C) and install a new one.
- Reinstall everything following the instructions in reverse. Tighten the screws (A) with a torque of **23 Nm**.

9.10 - LUBRICATION

9.10.1 - GREASING THE COUPLING

Every 8 hours or every day, grease the rotor supports via the grease nipples.

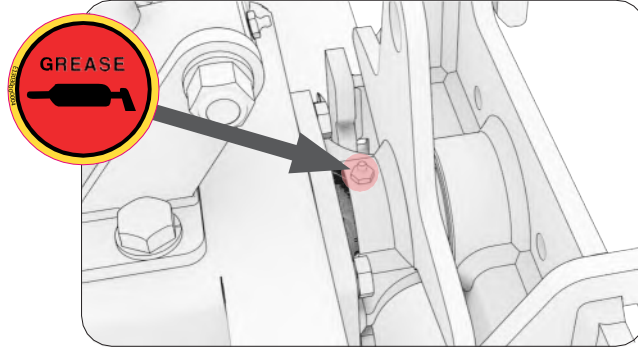

9.10.2 - GREASING THE ROTOR SUPPORTS

Every 4 hours, grease the rotor supports via the grease nipples.

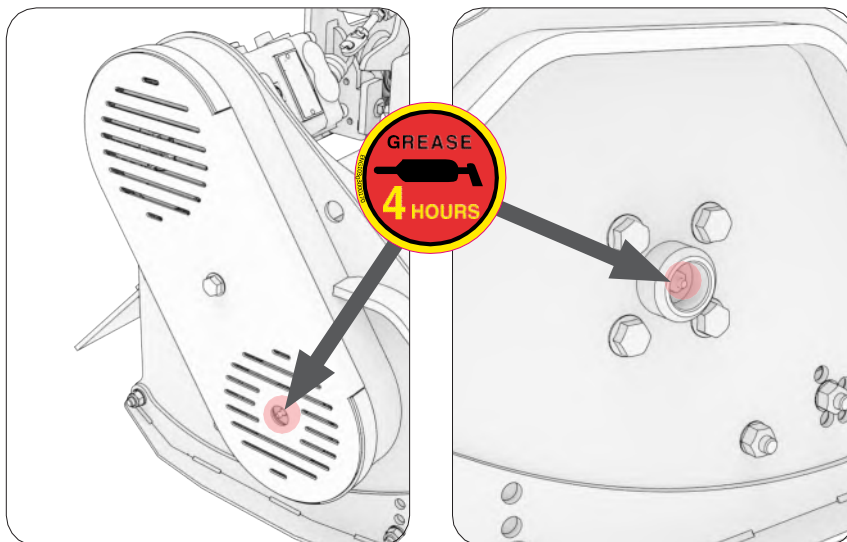

9.10.3 - GREASING THE SUPPORT ROLLER

Every 4 hours, grease the rotor supports via the grease nipples.

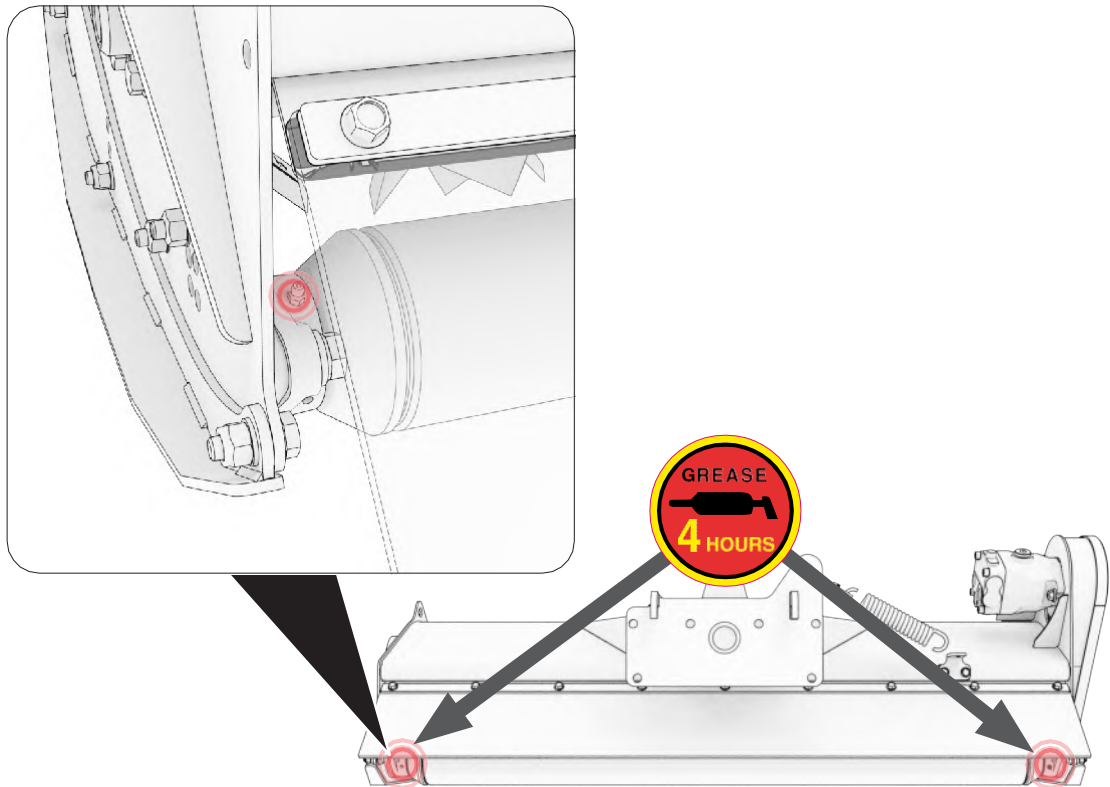

9.10.4 - GREASING THE SAFETY GUARD OPENING CYLINDER

Every 8 hours or every day, grease the safety guard opening cylinder via the grease nipples.

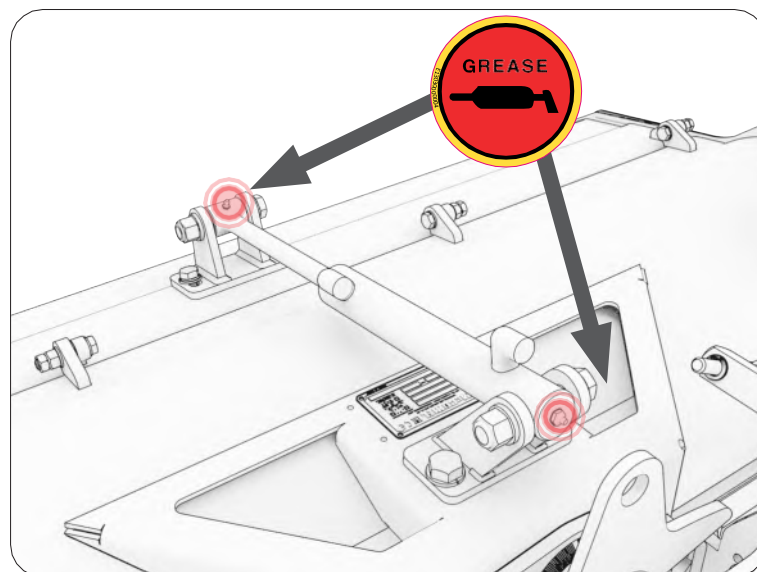

9.11 – PERIODIC COMPONENT REPLACEMENT

To guarantee safety at all times when the machine is being used, the operator is required to periodically replace the components listed below.

- **Hydraulic hoses:** every 4000 hours or every 6 years (whichever occurs first)

9.12 - MAINTENANCE OPERATIONS

MAINTENANCE FREQUENCY

Component		Period				
		After the first 4 hours	Every 4 hours	Every 8 hours / Daily	Every 40 hours / Weekly	Every 4000 hours or every 6 years
BELT	Tensioning	X ^(A)			X	
FLAILS	Check			X		
GUARDS	Check			X		
ROTOR SUPPORTS	Greasing		X			
SUPPORT ROLLER	Greasing		X			
HEAD	Greasing			X		
HYDRAULIC PIPES	Check			X		
	Substitution					X

^(A) Only first check.

10 - INSTRUCTIONS FOR EMERGENCY SITUATIONS

10.1 - FIRE

In case of fire, use a fire extinguisher in accordance with current regulations. If the machine catches fire or it is dangerously close to a fire, raise the alarm and contact the fire service.

11 - TIGHTENING CHART

11.1 - COARSE PITCH BOLTS

Diameter (mm)	Pitch (mm)	Coefficient of friction	8.8		10.9		12.9	
			Preload	Tightening torque	Preload	Tightening torque	Preload	Tightening torque
			N	Nm	N	Nm	N	Nm
M2	0.40	0.14	899	0.37	1,264.3	0.52	1,517.1	0.63
M2.5	0.45	0.14	1499.8	0.77	2,109.1	1.08	2,531	1.30
M3	0.50	0.14	2,251.9	1.34	3,166.7	1.88	3,800	2.26
M3.5	0.60	0.14	3,022.6	2.05	4,250.6	2.89	5,100.7	3.47
M4	0.70	0.14	3,901.9	3.06	5,487	4.30	6,584.4	5.16
M5	0.80	0.14	6,393.7	6.04	8,991.1	8.50	10,789.3	10.20
M6	1.00	0.14	8,998.2	10.37	12,653.7	14.59	15,184.4	17.51
M7	1.00	0.14	13,199.2	17.21	18,561.4	24.20	22,273.6	29.04
M8	1.25	0.14	16,531.2	25.07	23,247	35.26	27,896.5	42.31
M10	1.50	0.14	26,334.8	49.52	37,033.3	69.64	44,439.9	83.56
M12	1.75	0.14	38,408	84.84	54,011.2	119.31	64,813.5	143.17
M14	2.00	0.14	52,522.4	135.13	73,859.6	190.02	88,631.5	228.03
M16	2.00	0.14	72,728.5	211.61	102,274.4	297.58	122,729.3	357.09
M18	2.50	0.14	87,372.3	290.32	123,711	402.26	148,453.2	489.92
M20	2.50	0.14	113,494.2	412.78	156,601.2	580.47	191,521.5	696.56
M22	2.50	0.14	141,583.7	567.58	199,102.1	798.16	238,922.5	957.80
M24	3.00	0.14	16,523.6	713.68	229,955.1	1,003.61	275,946.1	1,204.33
M27	3.00	0.14	21,488.3	1,050.16	302,179.2	1,476.79	362,615	1,772.15
M30	3.50	0.14	26,541.2	1,428.97	367,792.3	2,009.49	441,350.8	2,411.39
M33	3.50	0.14	326,115.9	1,940.86	458,600.5	2,729.33	550,320.6	3,275.19
M36	4.00	0.14	382,483.6	2,496.81	537,867.6	3,511.14	645,441.1	4,213.37
M39	4.00	0.14	459,805.2	3,241.92	646,601	4,558.96	775,921.3	5,470.75
M42	4.50	0.14	525,878	4,010.93	739,516	5,640.37	887,419.2	6,768.44
M45	4.53	0.14	618,303.6	5,039.09	869,489.3	7,086.23	1,043,387	8,503.47
M48	5.00	0.14	691,725.8	6,036.23	972,739.4	8,488.45	1,167,287	10,186.14

11.2 - FINE PITCH BOLTS

Diameter (mm)	Pitch (mm)	Coefficient of friction	8.8		10.9		12.9	
			Preload	Tightening torque	Preload	Tightening torque	Preload	Tightening torque
			N	Nm	N	Nm	N	Nm
M8	1	0.14	18,159.1	27.05	25,536.2	38.04	30,643.4	45.65
M10	1	0.14	28,350.1	52.55	39,867.3	73.89	47,840.8	88.67
M10	1	0.14	30,443.3	55.61	42,810.8	78.2	51,373	93.84
M12	2	0.14	40,811.6	89.06	57,391.3	125.24	68,869.5	150.29
M12	1	0.14	43,338.4	93.41	60,944.6	131.36	73,133.5	157.63
M14	2	0.14	58,691.9	147.85	82,535.4	207.91	99,042.5	249.49
M16	2	0.14	79,175.5	226.12	111,340.6	317.98	133,608.7	381.57
M18	2	0.14	95,503.3	310.05	134,301.6	436	161,161.9	523.2
M 18	2	0.14	103,155.2	329.35	145,062.1	463.15	174,074.5	555.77
M20	2	0.14	121,772.4	436.34	171,242.5	613.61	205,491	736.33
M20	2	0.14	130,638.1	461.1	183,709.9	648.42	220,451.9	778.1
M22	2	0.14	151,067.8	597.49	212,439.1	840.22	254,927	1,008.27
M22	2	0.14	160,663.6	626.82	225,933.2	881.46	271,119.8	1,057.75
M24	2	0.14	183,386.5	780.67	257,887.3	1,097.82	309,464.8	1,371.38
M24	2	0.14	194,192.1	816.24	273,082.6	1,147.84	327,699.1	1,377.41
M27	2	0.14	238,370.1	1,139.34	335,207.9	1,602.2	402,249.5	1,922.64
M30	2	0.14	299,914	1,590.29	421,754.2	2,236.34	506,105	2,683.61
M33	2	0.14	368,980.2	2,136.49	518,878.4	3,004.43	622,654	3,605.32
M36	3	0.14	413,097.9	2,652.26	580,918.9	3,729.74	697,102.7	4,475.68
M39	3	0.14	494,054.1	3,430.3	694,763.5	4,823.86	833,716.1	5,788.63
M42	3	0.14	582,537.4	4,349.18	819,193.3	6,116.04	983,031.9	7,339.24
M45	3	0.14	676,135.5	5,401.43	950,815.6	7,595.77	1,140,979	9,114.92
M48	3	0.14	774,830.6	6,594.93	1,089,606	9,274.12	1,307,527	11,128.94
M45	4.53	0.14	618,303.6	5,039.09	869,489.3	7,086.23	1,043,387	8,503.47
M48	5.00	0.14	691,725.8	6,036.23	972,739.4	8,488.45	1,167,287	10,186.14

11.3 - FITTINGS TIGHTENING CHART

Series	Pipe diam.	THREAD - TIGHTENING TORQUE					
		Ø Thread metric	Shape B MT (Nm)	Shape E MT (Nm)	Ø Thread Gas	Shape B MT (Nm)	Shape E MT (Nm)
Light	6	M 10x1.0	18	18	G 1/8	18	18
	8	M 12 x 1.5	30	25	G 1/4	35	35
	10	M 14 x 1.5	45	45	G 1/4	35	35
	12	M 16 x 1.5	65	55	G 3/8	70	70
	15	M 18 x 1.5	80	70	G 1/2	140	90
	18	M 22 x 1.5	140	125	G 1/2	100	90
	22	M 26 x 1.5	190	180	G 3/4	180	180
	28	M 33 x 2.0	340	310	G 1	330	310
	35	M 42 x 2.0	500	450	G 1 1/4	540	450
	42	M 48 x 2.0	630	540	G 1 1/2	630	540
Strong	6	M 12 x 1.5	35	35	G 1/4	55	40
	8	M 14 x 1.5	55	45	G 1/4	55	40
	10	M 16 x 1.5	70	70	G 3/8	90	80
	12	M 18 x 1.5	110	90	G 3/8	90	80
	14	M 20 x 1.5	150	125	G 1/2	150	115
	16	M 22 x 1.5	170	135	G 1/2	130	115
	20	M 27 x 2.0	270	180	G 3/4	270	180
	25	M 33 x 2.0	410	310	G 1	340	310
	30	M 42 x 2.0	540	450	G 1 1/4	540	450
	38	M 48 x 2.0	700	540	G 1 1/2	700	540



Twose, Temeside Works, Ludlow, Shropshire SY8 1JL. England.
Telephone: 01584 873131. Website: www.twose.com.