

Publication 772
October 2014
Part No. 22675.72
Revision: 08.11.18

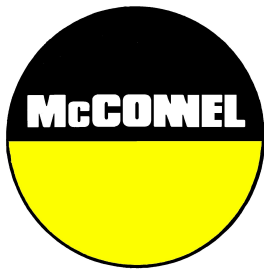

McCONEl

FORESTRY & MULCHER HEADS

ROBOCUT ATTACHMENTS

Builds 04/15 onwards from S/No.130F0116040182

Operation Manual



IMPORTANT

VERIFICATION OF WARRANTY REGISTRATION



Dealer Warranty Information & Registration Verification

It is imperative that the selling dealer registers this machine with McConnel Limited before delivery to the end user – failure to do so may affect the validity of the machine warranty.

To register machines; log onto <https://my.mcconnel.com> and select 'Machine Registration' which can be found in the 'Warranty' section of the site. **Confirm to the customer that the machine has been registered by completing the verification form below.**

Registration Verification	Serial No. <input type="text"/>
Dealer Name:	
Dealer Address:	
Customer Name:	
Date of Warranty Registration:/...../..... Dealer Signature:	

Note to Customer / Owner

Please ensure the section above has been completed and signed by the dealer to verify your machine has been registered with McConnel Limited.

IMPORTANT: During the initial 'bedding in' period of a new machine it is the customer's responsibility to regularly inspect all nuts, bolts and hose connections for tightness and re-tighten if required. New hydraulic connections occasionally weep small amounts of oil as the seals and joints settle in – where this occurs it can be cured by re-tightening the connection – *refer to torque settings chart below*. The tasks stated above should be performed on an hourly basis during the first day of work and at least daily thereafter as part of the machine's general maintenance procedure.

CAUTION: DO NOT OVER TORQUE HYDRAULIC FITTINGS AND HOSES

Torque Settings for Hydraulic Fittings

Hydraulic Hose Ends		
BSP	Setting	Metric
1/4"	18 Nm	19 mm
3/8"	31 Nm	22 mm
1/2"	49 Nm	27 mm
5/8"	60 Nm	30 mm
3/4"	80 Nm	32 mm
1"	125 Nm	41 mm
1.1/4"	190 Nm	50 mm
1.1/2"	250 Nm	55 mm
2"	420 Nm	70 mm

Port Adaptors with Bonded Seals		
BSP	Setting	Metric
1/4"	34 Nm	19 mm
3/8"	47 Nm	22 mm
1/2"	102 Nm	27 mm
5/8"	122 Nm	30 mm
3/4"	149 Nm	32 mm
1"	203 Nm	41 mm
1.1/4"	305 Nm	50 mm
1.1/2"	305 Nm	55 mm
2"	400 Nm	70 mm

WARRANTY POLICY

WARRANTY REGISTRATION

All machines must be registered, by the selling dealer with McConnel Ltd, before delivery to the end user. On receipt of the goods it is the buyer's responsibility to check that the Verification of Warranty Registration in the Operator's Manual has been completed by the selling dealer.

1. LIMITED WARRANTIES

1.01. *All mounted machines supplied by McConnel Ltd are warranted to be free from defects in material and workmanship from the date of sale to the original purchaser for a period of 12 months, unless a different period is specified.*

All Self Propelled Machines supplied by McConnel Ltd are warranted to be free from defects in material and workmanship from the date of sale to the original purchaser for a period of 12 months or 1500 hours. Engine warranty will be specific to the Manufacturer of that unit.

1.02. *All spare parts supplied by McConnel Ltd and purchased by the end user are warranted to be free from defects in material and workmanship from the date of sale to the original purchaser for a period of 6 months. All parts warranty claims must be supported by a copy of the failed part invoice to the end user. We cannot consider claims for which sales invoices are not available.*

1.03. *The warranty offered by McConnel Ltd is limited to the making good by repair or replacement for the purchaser any part or parts found, upon examination at its factory, to be defective under normal use and service due to defects in material or workmanship. Returned parts must be complete and unexamined. Pack the component(s) carefully so that any transit damage is avoided. All ports on hydraulic items should be drained of oil and securely plugged to prevent seepage and foreign body ingress. Certain other components, electrical items for example, may require particular care when packing to avoid damage in transit.*

1.04. *This warranty does not extend to any product from which McConnel Ltd's serial number plate has been removed or altered.*

1.05. *The warranty policy is valid for machines registered in line with the terms and conditions detailed and on the basis that the machines do not extend a period of 24 months or greater since their original purchase date, that is the original invoice date from McConnel Limited. Machines that are held in stock for more than 24 months cannot be registered for warranty.*

1.06. *This warranty does not apply to any part of the goods, which has been subjected to improper or abnormal use, negligence, alteration, modification, fitment of non-genuine parts, accident damage, or damage resulting from contact with overhead power lines, damage caused by foreign objects (e.g. stones, iron, material other than vegetation), failure due to lack of maintenance, use of incorrect oil or lubricants, contamination of the oil, or which has served its normal life. This warranty does not apply to any expendable items such as blades, belts, clutch linings, filter elements, flails, flap kits, skids, soil engaging parts, shields, guards, wear pads, pneumatic tyres or tracks.*

1.07. *Temporary repairs and consequential loss - i.e. oil, downtime and associated parts are specifically excluded from the warranty.*

1.08. *Warranty on hoses is limited to 12 months and does not include hoses which have suffered external damage. Only complete hoses may be returned under warranty, any which have been cut or repaired will be rejected.*

1.09. *Machines must be repaired immediately a problem arises. Continued use of the machine after a problem has occurred can result in further component failures, for which McConnel Ltd cannot be held liable, and may have safety implications.*

1.10. *If in exceptional circumstances a non McConnel Ltd part is used to effect a repair, warranty reimbursement will be at no more than McConnel Ltd's standard dealer cost for the genuine part.*

- 1.11. *Except as provided herein, no employee, agent, dealer or other person is authorised to give any warranties of any nature on behalf of McConnell Ltd.*
- 1.12. *For machine warranty periods in excess of 12 months the following additional exclusions shall apply:*
 - 1.12.1. *Hoses, exposed pipes and hydraulic tank breathers.*
 - 1.12.2. *Filters.*
 - 1.12.3. *Rubber mountings.*
 - 1.12.4. *External electric wiring.*
 - 1.12.5. *Bearings and seals*
 - 1.12.6. *External Cables, Linkages*
 - 1.12.7. *Loose/Corroded Connections, Light Units, LED's*
 - 1.12.8. *Comfort items such as Operator Seat, Ventilation, Audio Equipment*
- 1.13. *All service work, particularly filter changes, must be carried out in accordance with the manufacturer's service schedule. Failure to comply will invalidate the warranty. In the event of a claim, proof of the service work being carried out may be required.*
- 1.14. *Repeat or additional repairs resulting from incorrect diagnosis or poor quality previous repair work are excluded from warranty.*

NB Warranty cover will be invalid if any non-genuine parts have been fitted or used. Use of non-genuine parts may seriously affect the machine's performance and safety. McConnell Ltd cannot be held responsible for any failures or safety implications that arise due to the use of non-genuine parts.

2. REMEDIES AND PROCEDURES

- 2.01. *The warranty is not effective unless the Selling Dealer registers the machine, via the McConnell web site and confirms the registration to the purchaser by completing the confirmation form in the operator's manual.*
- 2.02. *Any fault must be reported to an authorised McConnell Ltd dealer as soon as it occurs. Continued use of a machine, after a fault has occurred, can result in further component failure for which McConnell Ltd cannot be held liable.*
- 2.03. *Repairs should be undertaken within two days of the failure. Claims submitted for repairs undertaken more than 2 weeks after a failure has occurred, or 2 days after the parts were supplied will be rejected, unless the delay has been authorised by McConnell Ltd. Please note that failure by the customer to release the machine for repair will not be accepted as a reason for delay in repair or submitting warranty claims.*
- 2.04. *All claims must be submitted, by an authorised McConnell Ltd Service Dealer, within 30 days of the date of repair.*
- 2.05. *Following examination of the claim and parts, McConnell Ltd will pay, at their discretion, for any valid claim the invoiced cost of any parts supplied by McConnell Ltd and appropriate labour and mileage allowances if applicable.*
- 2.06. *The submission of a claim is not a guarantee of payment.*
- 2.07. *Any decision reached by McConnell Ltd. is final.*

3. LIMITATION OF LIABILITY

- 3.01. *McConnell Ltd disclaims any express (except as set forth herein) and implied warranties with respect to the goods including, but not limited to, merchantability and fitness for a particular purpose.*
- 3.02. *McConnell Ltd makes no warranty as to the design, capability, capacity or suitability for use of the goods.*
- 3.03. *Except as provided herein, McConnell Ltd shall have no liability or responsibility to the purchaser or any other person or entity with respect to any liability, loss, or damage caused or alleged to be caused directly or indirectly by the goods including, but not limited to, any indirect, special, consequential, or incidental damages resulting from the use or operation of the goods or any breach of this warranty. Notwithstanding the above limitations and warranties, the manufacturer's liability hereunder for damages incurred by the purchaser or others shall not exceed the price of the goods.*
- 3.04. *No action arising out of any claimed breach of this warranty or transactions under this warranty may be brought more than one (1) year after the cause of the action has occurred.*

4. MISCELLANEOUS

- 4.01. McConnel Ltd may waive compliance with any of the terms of this limited warranty, but no waiver of any terms shall be deemed to be a waiver of any other term.*
- 4.02. If any provision of this limited warranty shall violate any applicable law and is held to be unenforceable, then the invalidity of such provision shall not invalidate any other provisions herein.*
- 4.03. Applicable law may provide rights and benefits to the purchaser in addition to those provided herein.*

McConnel Limited

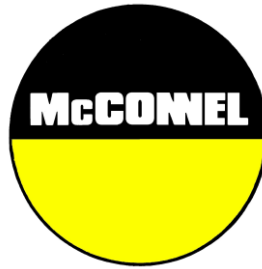

For Safety and Performance...

ALWAYS READ THE BOOK FIRST

McCONEL LIMITED

**Temeside Works
Ludlow
Shropshire
England**

**Telephone: +44 (0)1584 873131
www.mcconel.com**

▲ WARNING

Cancer and Reproductive Harm
www.P65Warnings.ca.gov

D960

Operating, servicing and maintaining this equipment can expose you to chemicals including gasoline, diesel fuel, lubricants, petroleum products, engine exhaust, carbon monoxide, and phthalates, which are known to the State of California to cause cancer and birth defects or other reproductive harm. To minimize exposure, avoid breathing exhaust, do not idle the engine except as necessary, service your vehicle in a well-ventilated area and wear gloves or wash your hands frequently when servicing your vehicle. Battery posts, terminals and related accessories contain lead and lead compounds, chemicals known to the state of California to cause cancer, birth defects or other reproductive harm. For more information go to www.P65Warnings.ca.gov. This website, operated by California's Office of Environmental Health Hazard Assessment, provides information about these chemicals and how individuals may be exposed to them.

CONTENTS

General Information	1
Introduction	2
Technical Specifications	3
Machine Handling	3
Component Identification	4
Safety Information	5
Machine Attachment	7
Set-Up & Adjustment	8
Operation	9
Maintenance	11
Troubleshooting	15

GENERAL INFORMATION

Always read this manual before attempting to operate the machine – whenever any doubt exists contact your dealer or the McConnel Service Department for advice and assistance.

Use only McConnel Genuine Service Parts on McConnel Equipment and Machines

DEFINITIONS – *The following definitions apply throughout this manual:*

WARNING

An operating procedure, technique etc., which –
can result in personal injury or loss of life if not observed carefully.

CAUTION

An operating procedure, technique etc., which –
can result in damage to either machine or equipment if not observed carefully.

NOTE

An operating procedure, technique etc., which is –
considered essential to emphasis.

LEFT AND RIGHT HAND

These terms are applicable to the machine when it is viewed from the rear facing forwards.

Note: The illustrations in this manual are for instructional purposes only and may on occasion not show some components in their entirety. In some instances an illustration may appear slightly different to that of your particular model but the general procedure will be the same. E&OE.

MACHINE & DEALER INFORMATION

Record the Serial Number of your machine on this page and always quote this number when ordering parts. Whenever information concerning the machine is requested remember also to state the make and model of tractor to which the machine is fitted.	
Machine Serial Number:	Installation Date:
Machine Model details:	
Dealer Name:	
Dealer Address:	
Dealer Telephone No:	
Dealer Email Address:	

INTRODUCTION

The Robo-Forest and Robo-Mulcher are heavy-duty flailhead attachments for use on McConel all-terrain remote control Robocut machines. Both flailheads offer a 1.25m cutting width and feature a steel push bar to aid the feeding of material into the machine.

The Robo-Forest head is equipped with a heavy-duty steel rotor armed with 50 hard-wearing tungsten carbide teeth. The rotor, which spins at 3000rpm, is capable of 'tearing' through a wide range of wooded growth materials from saplings to tree stumps and can mulch down materials up to 100mm thick.

The Robo-Mulcher head offers similar performance using 22 heavy-duty swinging hammer flails attached to a specially designed rotor that provides exceptional cutting momentum for pounding overgrowth and debris into a fine mulch.

These machines are ideal tools for use in the forestry industry and/or for contractors operating in dense overgrowth on difficult terrain or in areas where access is limited.

These machines should only be used to perform tasks for which they are designed – use of the machines for any other function can be dangerous to persons and damaging to components.



Robo-Mulcher Head

Robo-Forest Head

MACHINE IDENTIFICATION

Machines are fitted with an identification plate as illustrated opposite;

Always quote the machine type and serial number stated on the identification plate when ordering replacement parts.

MANUFACTURED BY			CE
DENOMINAZIONE DENOMINATION	<input type="text"/>		
NUMERO DI SERIE SERIAL NUMBER	<input type="text"/>		
PRESSIONE MAX MAX PRESSURE	MASSA WEIGHT	RPM MAX	<input type="text"/>
MODELLO TIPO MODEL TYPE	POTENZA POWER	ANNO FABBRICAZIONE MANUFACTURE YEAR	<input type="text"/>

TECHNICAL SPECIFICATIONS

Dimensions

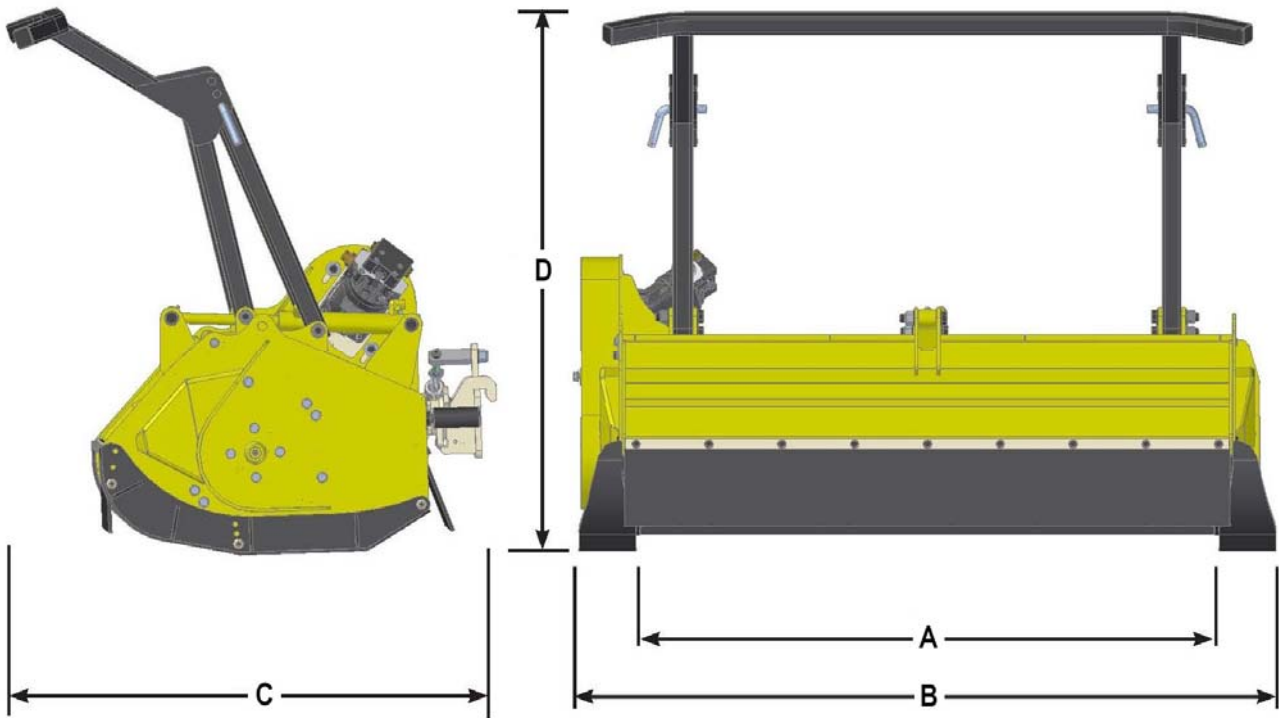

SPECIFICATION	ROBO-FOREST	ROBO-MULCHER
Working width (A)	1225mm	1225mm
Maximum width (B)	1480mm	1480mm
Maximum depth (C)	930mm	930mm
Maximum height (B)	1110mm	1110mm
Weight	355 Kg.	315 Kg.
Rotor speed (maximum)	3000rpm	3000rpm
Rotor tools (type)	Fixed teeth	Hammer flail
Rotor tools (quantity)	50	22

MACHINE HANDLING

Handling the Machine

Handling of the machine should be performed using suitable overhead lifting equipment with a minimum safe lifting capacity over and above the maximum weight of the machine. Always ensure the machine is balanced during the lifting procedure and that all bystanders are kept well clear of the raised machine.

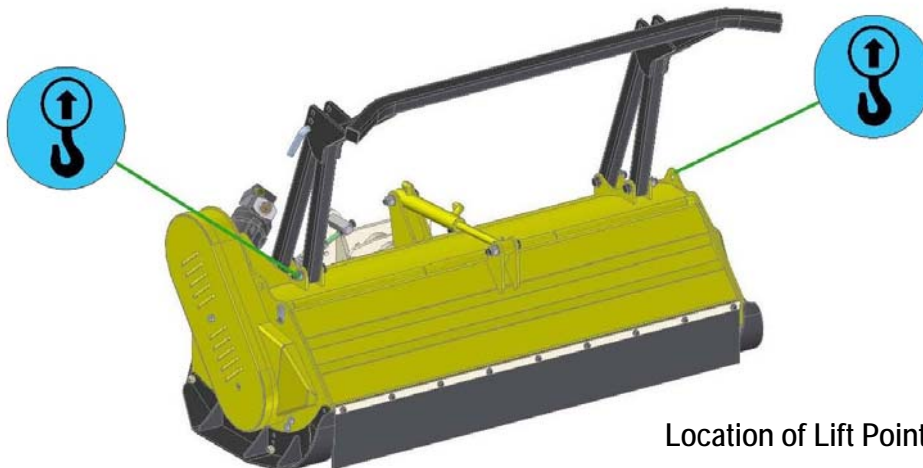

Location of Lift Points

MACHINE OVERVIEW

Component Identification & Location

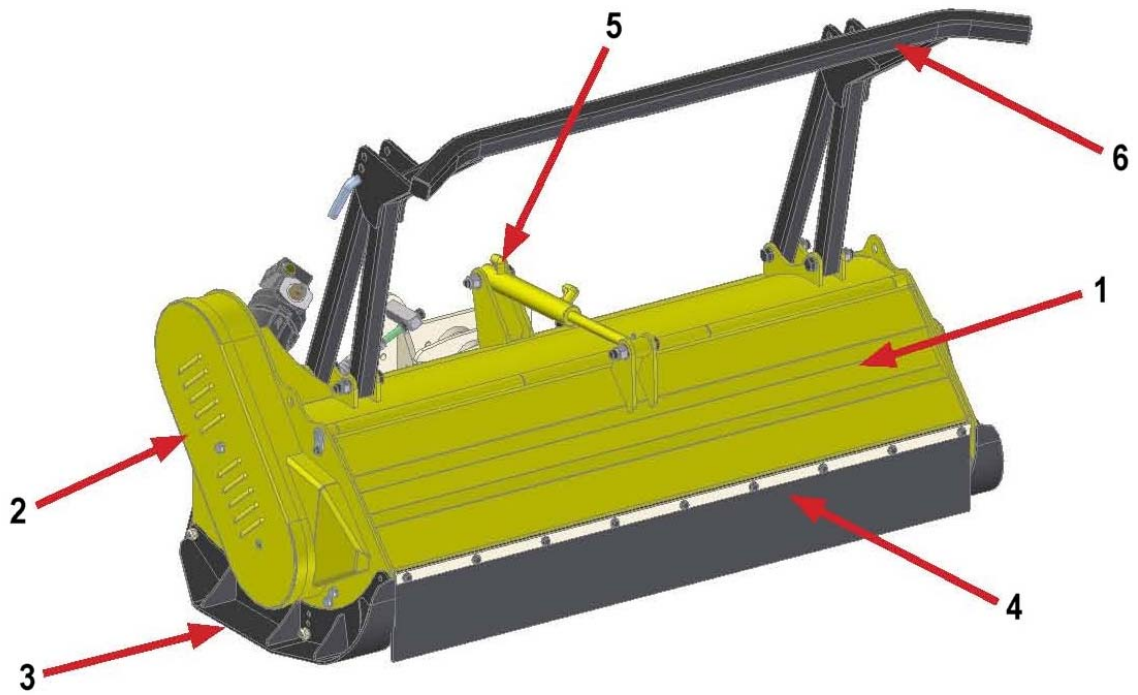

- | | |
|------------------------------------|-------------------------------|
| 1) Front Cover | 6) Push Bar (<i>Option</i>) |
| 2) Belt Drive Cover | 7) Upper Pulley (Motor) |
| 3) Side Skid | 8) Lower Pulley (Rotor) |
| 4) Rubber Protection Guard | 9) Drive Belt |
| 5) Hydraulic Ram (Cover Operation) | 10) Drive Belt Adjuster |

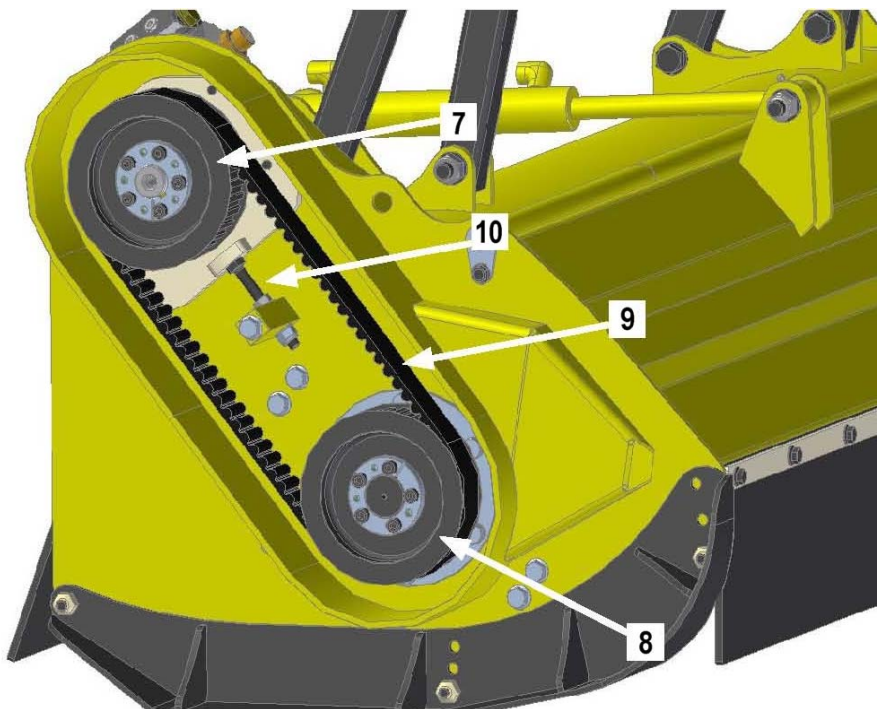

SAFETY INFORMATION

WARNING!



Ensure all operators are competent in the use of this machine as well as the Robocut machine to which it is attached. All users must read and fully understand all information regarding the safe operation of both machines.

General safety rules:

- ▲ Always read and follow the instructions for the use and maintenance of the machine before carrying out any work operations or servicing tasks.
- ▲ Improper use of the machine is both highly dangerous to persons and damaging to the machine components – only use the machine for its designated task.
- ▲ Both operators and the maintenance fitters should be familiar with the machine and fully aware of dangers surrounding improper use or incorrect repairs.
- ▲ Before starting, checks to both the carrying vehicle and the machine must be carried out with regard to: functionality, safety, and accident prevention.
- ▲ Immediately replace missing or damaged safety decals.
- ▲ Inspect the work area prior to operation and remove dangerous or hazardous objects.
- ▲ Even when using the machine correctly, stones or other objects may be thrown a long distance, therefore nobody must stand within the danger area. Special attention must be paid when working near roads, vehicles and buildings.
- ▲ The condition of cutting teeth/flails and of machine guards must be checked before beginning the daily work - they must be replaced if damaged or missing before attempting to use the machine.
- ▲ During checks or repairs, make sure nobody could start the machine by mistake.
- ▲ Protective clothing and safety equipment appropriate for the job must always be worn.
- ▲ Only operate the machine from a safe position with a clear uninterrupted view of the immediate work area.
- ▲ Before starting the machine, check the surrounding area for the likely presence of persons and/or animals.
- ▲ Never carry passengers on the machine.
- ▲ Never leave a running machine unattended.
- ▲ Never approach the machine until the rotor has completely stopped.
- ▲ Stop operating the machine immediately and switch it off if persons or animal enter the work zone and do not re-start until they are clear of the danger area (min.100 metres).
- ▲ Do not stand ahead of the machine whilst operating.
- ▲ Take extra care when working on rough or uneven terrain.
- ▲ Do not work on slopes in excess of the machines capability.
- ▲ Only operate the machine in daylight conditions or high quality artificial lighting.
- ▲ Before leaving the machine, park it safely on firm level site and remove the carrying vehicle's starting key.

Although the information given here covers a wide range of safety subjects, it is impossible to predict every eventuality that can occur under differing circumstances whilst operating this machine. No advice given here can replace 'good common sense' and 'total awareness' at all times, but will go a long way towards the safe use of your McConnel machine.

MACHINE SAFETY DECALS

Safety warning decals are located in a visible location on the machine; ensure all users understand and abide by the safety decal messages on the machines they are operating.

- 1. DANGER!**
Thrown object risk;
Keep clear of the working machine.
- 2. DANGER!**
Rotating components hazard;
Keep hands and feet clear at all times.
- 3. WARNING!**
Read the Manual;
Read the manual before operating.



1.

2.

3.



Safety decals should be kept in a clean readable condition at all times and must be replaced immediately if they are missing, damaged or unreadable.

OPERATOR PROTECTION

Personal Safety Gear



Users should wear suitable personal safety gear at all times whilst operating this machine.
Suggested safety gear is as follows;

- **Dust Mask**
- **Safety Boots**
- **Eye Protection** (*Safety Goggles, Safety Glasses with side shields or Safety Visor*).
- **Ear Defenders**
- **Safety Helmet**
- **Safety Gloves**
- **Overalls**

MACHINE ATTACHMENT

Attachment and removal of the machine must always be performed on a firm level site. Ensure bystanders are kept at a safe distance from the machines during the attachment process. The procedure for attaching the machine to a Robocut is as follows;

- Align the Robocut so that its mounting plate (A) is centred and parallel to the flailhead mounting plate (B).
- Lower the Robocut mounting plate (A) and move the Robocut slowly forwards until the two plates are in contact with each other.
- Raise the Robocut mounting plate (A) until it fully connects with the flailhead mounting plate (B).
- Turn off the Robocut and remove the security key from the controls.
- Fix Robocut mounting plate to flailhead mounting plate via the mounting location holes (C) using the 6 mounting bolts.
- Adjust the machine's 2 lateral support pins (D) so they are placed into contact with the Robocut's front mounting plate – refer to photo below.

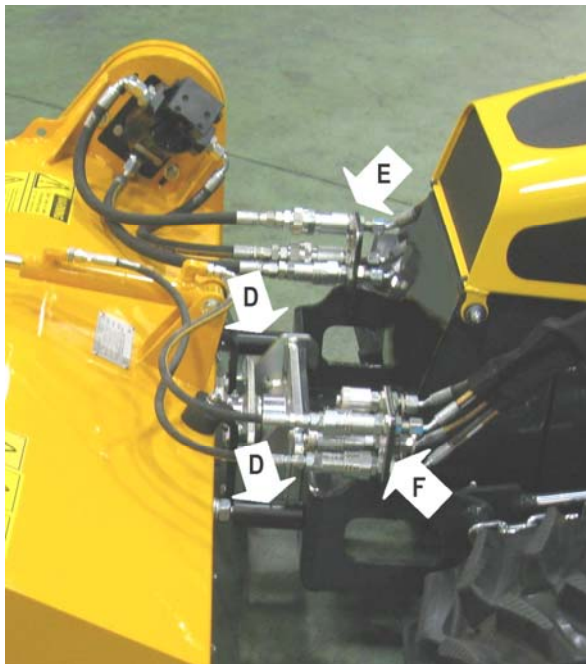
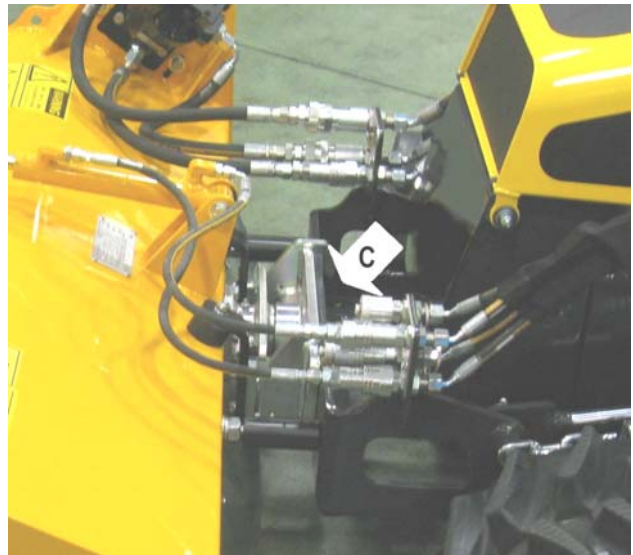
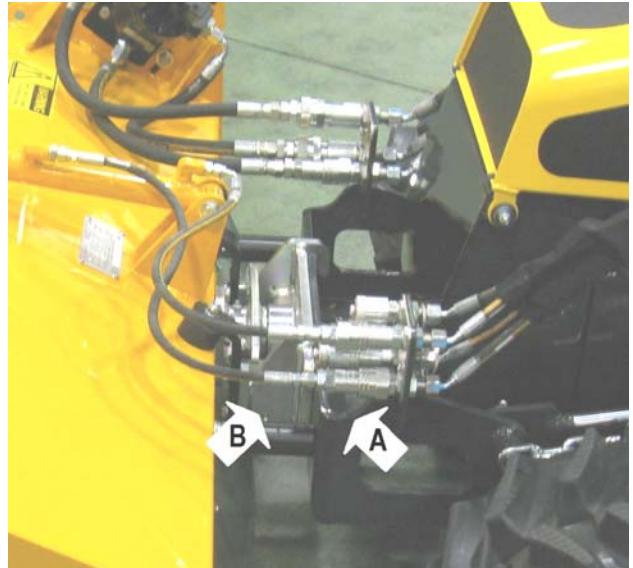

- Connect the machines 'quick release' hoses to the external hydraulic points 'E' & 'F' on the Robocut. Motor hoses are connected at positions 'E' and hydraulic ram hoses are connected at positions 'F' - refer to photo opposite.
- Start the Robocut and carefully operate the controls for the flailhead to verify that all functions are operating correctly.



WARNING! Ensure the machine is parked in a safe location and any onlookers and/or bystanders remain at a safe distance from the machine at all times when operating the flailhead to test the functions.

MACHINE SET-UP & ADJUSTMENT



WARNING!

Machine set-up and adjustments must always be performed on a firm level site with the Robocut engine switched off and the starting key removed.

Lateral Supports (Thrust Pins)

The rear casing of the machine is fitted with thrust pins on each side of its mounting; these are to provide lateral support in the event of accidental impact, thus reducing stress on the central mounting point.

When mounting the machine the thrust pins must be adjusted to place them in touch contact with the Robocut's frontal mounting plate. Adjustment is performed by rotating the pins to extend them until they are in contact with the mounting plate.

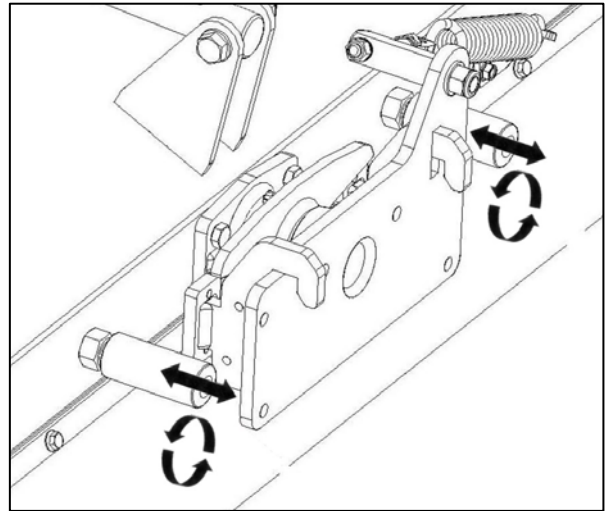

Skids Adjustment

Machines are equipped with adjustable skids on each side of the machine which can be set at any one of 3 height positions; *the height setting chosen will determine the cutting height of the rotor.*

To adjust the skid height the rear bolt 'A' must be slackened off and the frontal bolts 'B' & 'C' removed; this will allow the front of the skid to be pivoted into a higher or lower position. With the height setting selected; replace bolts 'B' and 'C' before fully tightening all 3 bolts.

Repeat the procedure on the opposing skid ensuring the same exact same height position is selected.

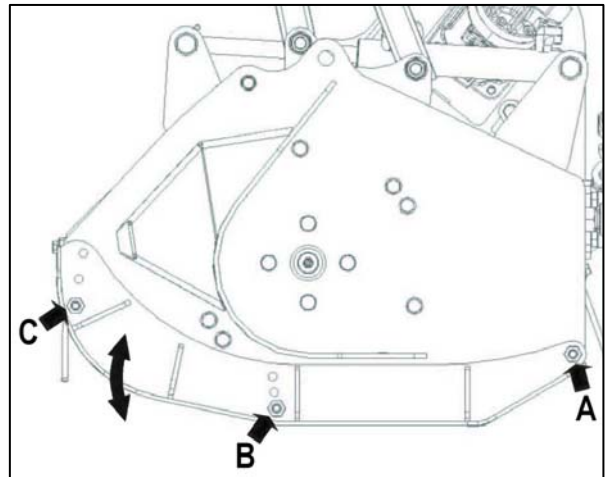

WARNING! Never attempt to use the machine with the side skids removed; flails should not be allowed to contact the ground. Do not attempt to adjust skid heights when the machine is running.

Push Bar Adjustment

An optional push bar is available which aids the feeding of material into the machine by forcing it forward and downward ahead of the rotor - its position can be adjusted to suit the particular operating requirement.

Adjustment of the pusher bar is by removal of the nuts and bolts from the upper positions of the support bars and replacing them in an alternate hole position to alter the work angle; ensure when replacing the bolts that the same hole position is selected on each support.

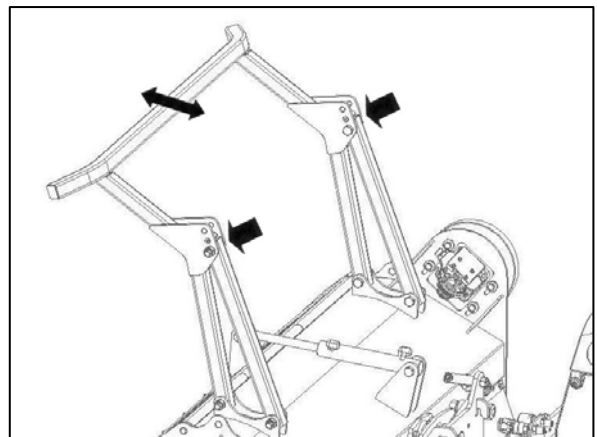

NOTE: Adjustment will require the use of a suitable lifting device to support the pusher bar whilst it is being adjusted.

OPERATION



Ensure that the operator is suitably qualified to use a machine of this nature and that they have fully read and understood all manuals for the machines being operated - they should be aware of all safety aspects relating to the safe use of the machines.

It is advisable that all 'first time' operators practice using the machine in a clear safe area prior to work in order to familiarise themselves with its operation.

After the initial first 2 hours of work with a new machine, nuts and bolts should be checked for tightness and tightened if required.

Pre-Operational Checks

Before commencing work with the machine the following checks should be performed;

- Make a visual inspection of the machine to ensure it is in good operational condition.
- Check all safety guarding is in position and in full working order.
- Check rotor for missing or damaged flails and replace if required.
- Check all greasing points are well lubricated.
- Check belt tension and adjust if required.

Transport

The following must be observed at all times when transporting the machine;

- Machine must always be switched off.
- Machine must be raised to a suitable transportation height.

Pre-Work

Prior to starting work the area should be checked for dangerous objects such as large stones, wire, glass etc. and any hazardous objects removed from the area prior to operation with the machine. The location of unmovable or natural hazards should be noted, or if necessary 'marked', to indicate to the operator that the area should either be avoided or additional caution adopted whilst working around the hazard.

Starting Work

With the machine switched off, lower it into a position approximately 10cm above the ground, start the machine and allow it to build up to the correct working speed before gently lowering the it onto the ground - the machine is now in its working position and forward travel into the work can begin.

Working Speed

The working speed will depend on the particular working conditions and nature of the material being cut, in all conditions speed should be kept to a pace at which the machine efficiently cuts and mulches the material.

Never operate at speeds that do not permit the operator sufficient time to avoid potential dangers or hazards or at speeds that place undue stress on the machine or its components.

Operating Position & Distance

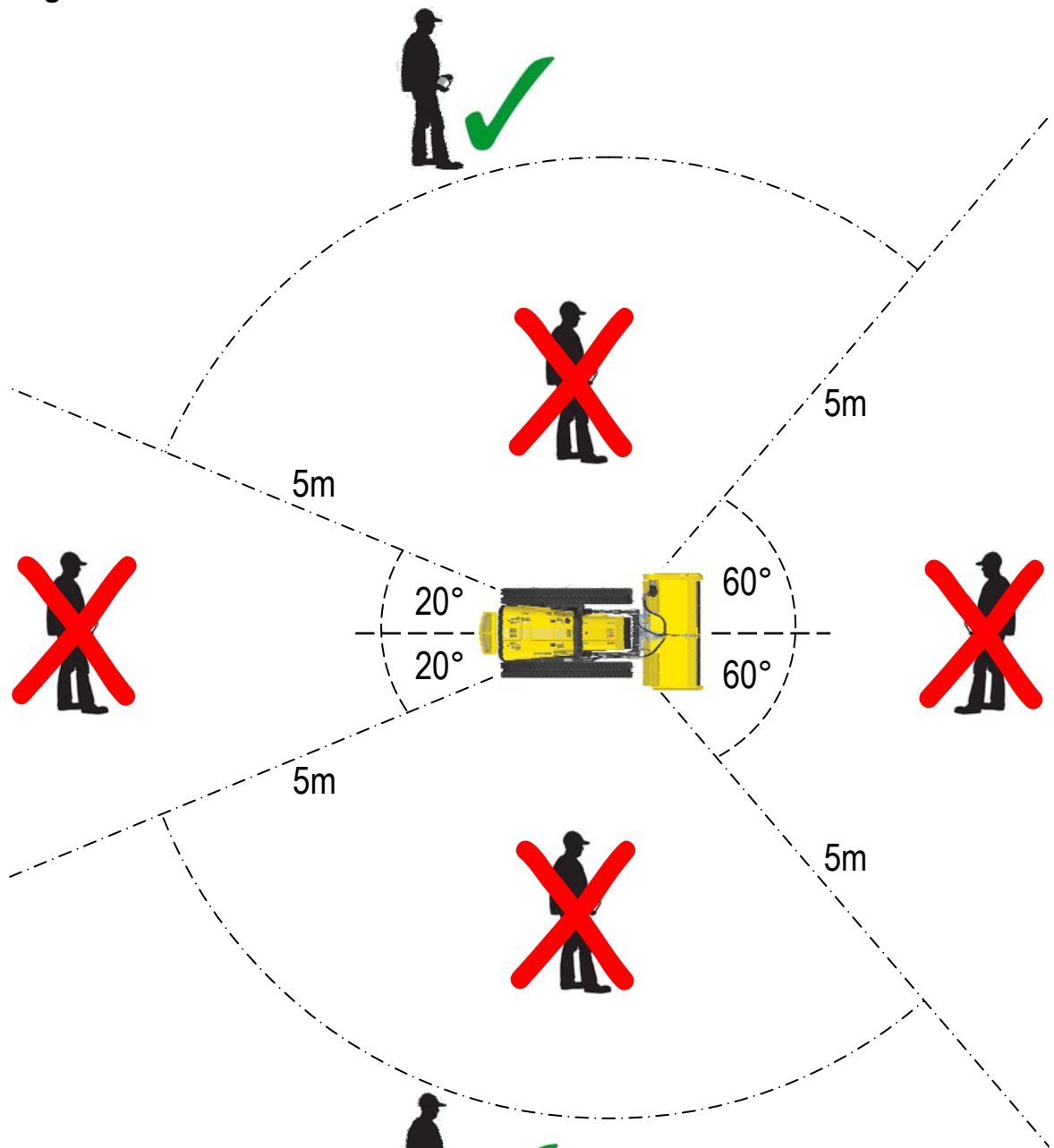

Slope Working

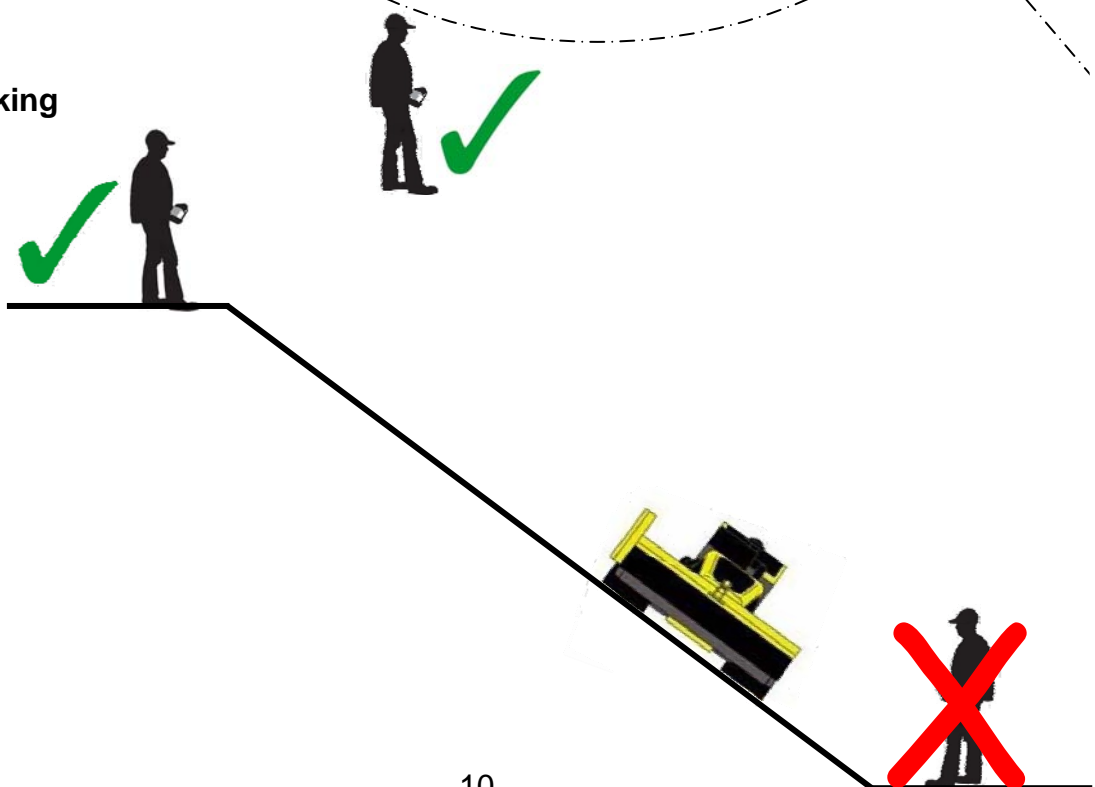

MAINTENANCE

Drive Belt

The drive belts utilized on these machines provide a transfer of power from the hydraulic system to the cuttershaft of the mower. This allows the belts to act much like a clutch and to slip on the pulleys when the mower encounters an obstruction or is severely overloaded. Belt slippage on the pulleys results in wear, and loss of tension which translates to a loss of mowing power from the cutter.

Access to the belt system is gained by removal the end cover. **Never run the machine with the belt cover removed.**

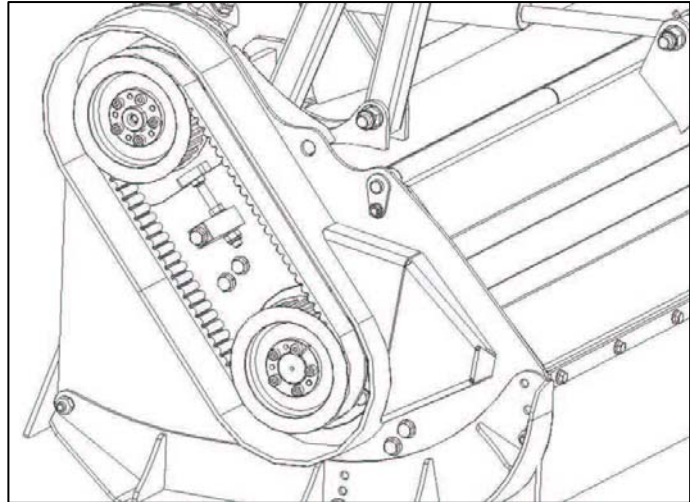

Drive Belt Tension

Belt tension is correct when the belt allows 1cm of deflection when a force of 10Kg is exerted on it. The measurement should be made at the belts mid-point position between the pulleys.

Belts should be inspected for signs of wear or damage and the tension checked and/or adjusted on a regular basis and always prior to operation.

Damaged or badly worn belts should be replaced immediately.

When fitting a new belt the tension should be re-checked after the first hour or so of work.

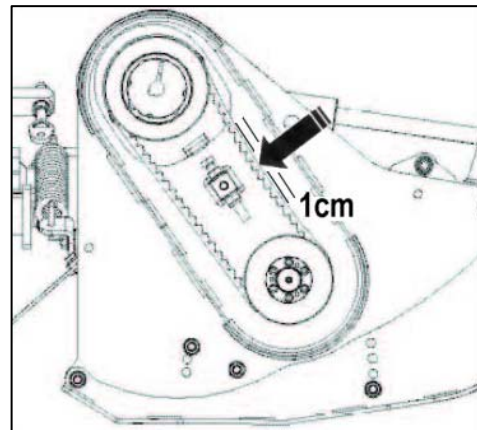

Belt Tension Adjustment

For belt tension adjustment the unit should be parked up resting on firm level ground and the machines hydraulic hoses disconnected.

The tensioning procedure is as follows;

Remove belt cover to allow access to the tension adjuster located on the back plate in-between the drive pulleys.

Loosen the hydraulic motor bolts sufficient only to allow the adjustment plate freedom to move.

Loosen the tension adjuster locknut and adjust the bolt to set the desired tension on the belt. Re-tighten the locknut and check the belt tension is correct; *setting is 1cm belt deflection at a force of 10Kg.*

Re-tighten the motor bolts to secure adjustment plate.

Replace belt cover before running the machine ensuring the covers lubrication access hole is located above grease fitting.

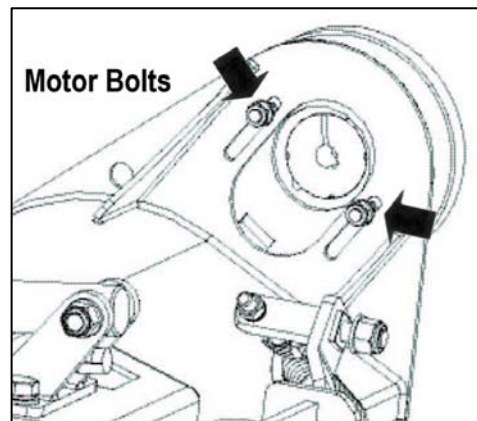
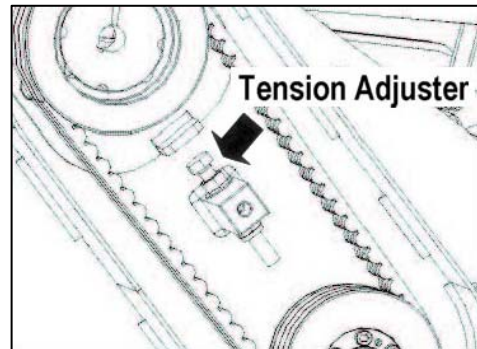

For extended storage it is advisable to remove belt tension and re-tension before next use.

Belt Replacement

When replacing a drive belt the procedure is the same as above other than the tensioner will need to be loosened sufficient to allow removal of the old belt and fitment of the new one.

Note: When fitting a new belt the tension should be re-checked after an initial hour or so of operation and, if required, re-tensioned to the correct setting.

Blade Inspection & Replacement

It is important that the flails/cutting teeth are inspected for signs of excessive wear or damage before using the machine and on a regular basis during the working day.

Rotor components that show signs of excessive wear or damage must be replaced immediately as total failure of these items can lead to broken parts being ejected at high velocity; this could cause catastrophic damage to the machine and/or serious bodily injury or even death. Always fit genuine McConnel replacement parts on these machines.

Blades must be replaced immediately if they show any of the following signs;

- *Bent or deformed from their original shape.*
- *Bolt hole worn.*
- *Cracks are visible.*
- *Deep gouges in the blade's surface.*
- *Leading edge is excessively worn or damaged.*

Part No. & Identification of Replacement Components

- | | | |
|-------------------------------|---|---|
| 1). 4001281 – Hammer Flail | } | Hammer Flail Kit ▶
Part No.4001280 |
| 2). 4001282 – Bolt | | |
| 3). 4001283 – Spacer | | |
| 4). 4001284 – Washer | | |
| 5). 05.282.08 – Spring Washer | | |
| 6). 4000249 – Locknut | | |

- | | | |
|---------------------------|---|--|
| 7). 4001254 – Fixed Tooth | } | Fixed Tooth Kit ▶
Part No.4001253 |
| 8). 4000751 – Locknut | | |

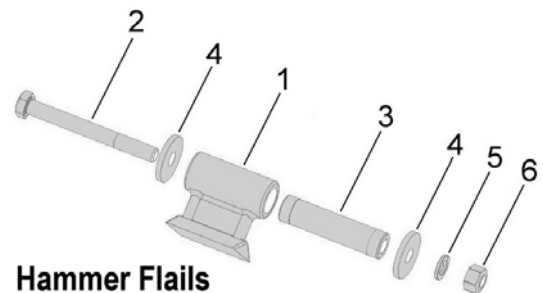

Hammer Flails

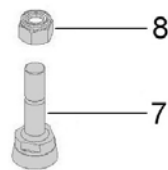

Fixed Teeth

Rotor Vibration

If vibration of the rotor is experienced the machine should be stopped immediately – this is often a sign that a flail is either missing or severely damaged, if this is the case do not use the machine until the problem has been rectified. If vibration continues, or occurs for no apparent reason, the rotor must be checked and if necessary rebalanced before using the machine again. Contact your local dealer for further advice or assistance on this subject.

Rotor Shaft Removal and Replacement

For complete replacement of blades and/or for balancing it is necessary to remove the rotor from the machine, *the procedure for this is as follows;*

Note: Suitable lifting equipment will be required to support the rotor during the removal procedure; ensure the equipment is fully capable of supporting and lifting the rotor in a safe manner.

Weight of Hammer Flail Rotor: 95Kg.

Weight of Fixed Teeth Rotor: 110Kg.

- Loosen all 4 bolts on the free end of the rotor.

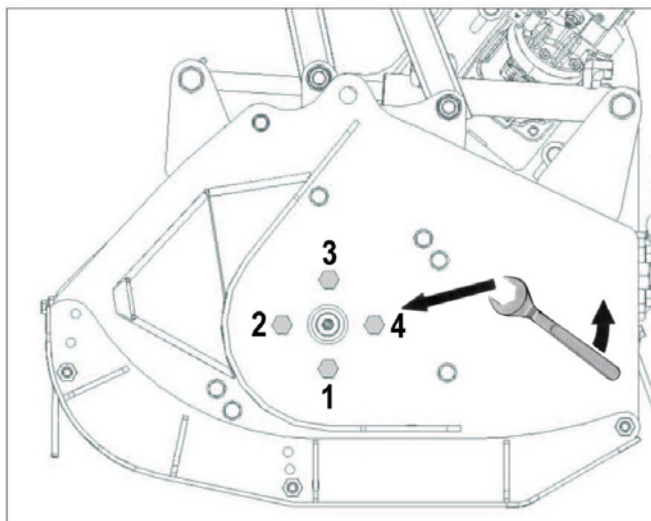

- Release drive belt tension and
- Remove drive belt.
- Remove lower drive pulley.

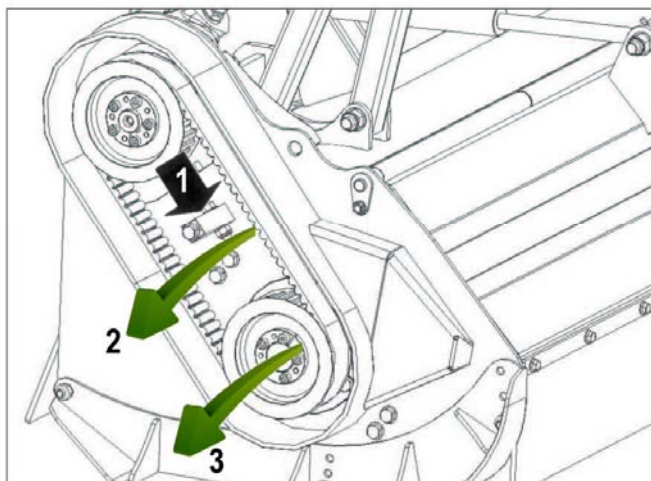

- Loosen the bolts on the rotor drive end flange.
- Attach lifting gear to secure and support the rotor.
- Removing all bolts from both ends of the rotor.
- Manoeuvre the rotor out of the casing.

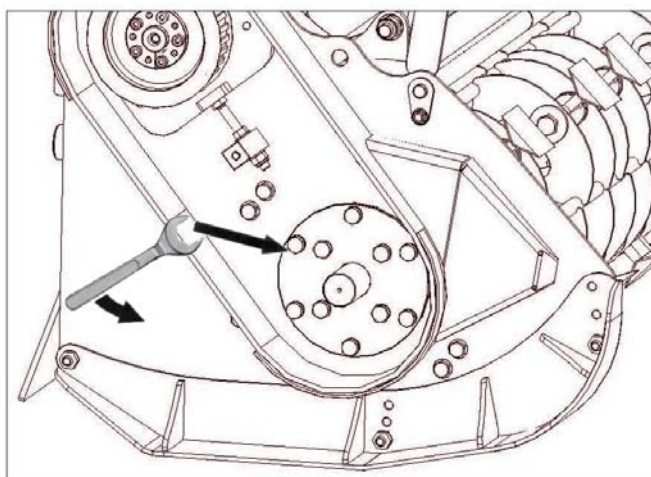

Refitting the Rotor Shaft

Replacing the rotor in the casing is basically a reversal of the removal procedure; ensure the bearing seal is correctly replaced and the drive pulleys aligned – see *photo opposite*.

Taper Lock Torque Setting = 40-45 Nm.

Refer to belt adjustment page for details of the belt tensioning procedure.

Ensure all fixings are correctly tightened and the belt cover is replaced before running the machine.



Daily Maintenance (Every 10 Hours)

- Lubricate all grease points.
- Inspect rotor for signs of missing, damaged or worn components.
- Check tightness of all fixings.
- Check hydraulic system for signs of leaks, wear or damage.
- Check condition of safety guards/covers.
- Inspect the machine to verify there are no signs of cracks on welds.

Expansion Vessel – Flail Head Hydraulic Circuit

Machines are provided with an 'Expansion Vessel' to protect the flail head's hydraulic system when the head has been removed from the machine. The Expansion Vessel attaches to the flail head drain line to permit oil escape for protection of the hydraulic motor's shaft seals.

The 'Expansion Vessel' must be installed on the flail head drain line at all times when the flail head is unattached.

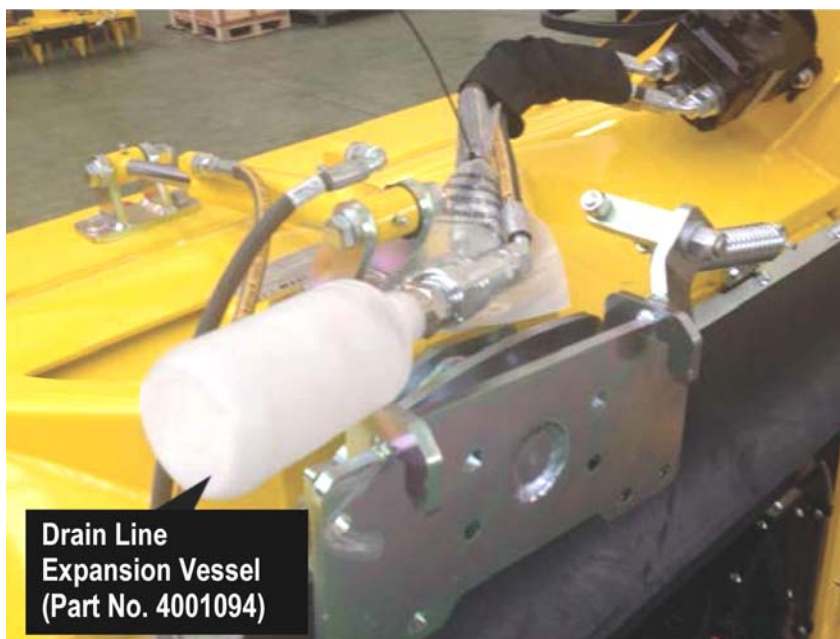

Troubleshooting Chart

Problem	Possible Cause	Suggested Remedy
Rotor will not turn.	Low oil pressure. Foreign object jamming rotor. Drive belt broken or slipping. Faulty rotor bearing. Internal pump or motor damage.	<i>Check oil pressure.</i> <i>Manually unblock the rotor.</i> <i>Check and replace or adjust.</i> <i>Replace bearing(s).</i> <i>Repair or replace if required.</i>
Unusual noise.	Damaged or missing flails. Worn flails.	<i>Check and replace flails.</i> <i>Fit new flails & fixings.</i>
Excessive vibration.	Mud and/or debris on rotor. Damaged or missing flails. Unbalanced or damaged rotor.	<i>Remove debris, clean rotor.</i> <i>Check and replace flails.</i> <i>Balance or replace rotor.</i>
Poor or uneven cutting.	Flails / teeth excessively worn	<i>Replace flails / teeth.</i>
Oil leakage.	Seals / hoses worn or damaged.	<i>Replace seals / hoses.</i>



McConnel Limited, Temeside Works, Ludlow, Shropshire SY8 1JL. England.
Telephone: 01584 873131. Facsimile: 01584 876463. www.mcconnel.com