

Publication 1086
November 2024
Part No. 24215.86



McCONEL

ROBO-MULCHER HEAD & ROBO-FOREST HEAD

1300 & 1600 (60/75HP) Models

Builds: 4060140/1/5/6 & 4080140/1/5/6

Operation Manual



IMPORTANT

VERIFICATION OF WARRANTY REGISTRATION



Dealer Warranty Information & Registration Verification

It is imperative that the selling dealer registers this machine with McConnel Limited before delivery to the end user – failure to do so may affect the validity of the machine warranty.

To register machines; log onto <https://my.mcconnel.com> and select 'Machine Registration' which can be found in the 'Warranty' section of the site. **Confirm to the customer that the machine has been registered by completing the verification form below.**

Registration Verification	Serial No. <input type="text"/>
Dealer Name:	
Dealer Address:	
Customer Name:	
Date of Warranty Registration:/...../.....	Dealer Signature:

Note to Customer / Owner

Please ensure the section above has been completed and signed by the dealer to verify your machine has been registered with McConnel Limited.

IMPORTANT: During the initial 'bedding in' period of a new machine it is the customer's responsibility to regularly inspect all nuts, bolts and hose connections for tightness and re-tighten if required. New hydraulic connections occasionally weep small amounts of oil as the seals and joints settle in – where this occurs it can be cured by re-tightening the connection – *refer to torque settings chart below*. The tasks stated above should be performed on an hourly basis during the first day of work and at least daily thereafter as part of the machine's general maintenance procedure.

CAUTION: DO NOT OVER TORQUE HYDRAULIC FITTINGS AND HOSES

Torque Settings for Hydraulic Fittings

Hydraulic Hose Ends		
BSP	Setting	Metric
1/4"	18 Nm	19 mm
3/8"	31 Nm	22 mm
1/2"	49 Nm	27 mm
5/8"	60 Nm	30 mm
3/4"	80 Nm	32 mm
1"	125 Nm	41 mm
1.1/4"	190 Nm	50 mm
1.1/2"	250 Nm	55 mm
2"	420 Nm	70 mm

Port Adaptors with Bonded Seals		
BSP	Setting	Metric
1/4"	34 Nm	19 mm
3/8"	47 Nm	22 mm
1/2"	102 Nm	27 mm
5/8"	122 Nm	30 mm
3/4"	149 Nm	32 mm
1"	203 Nm	41 mm
1.1/4"	305 Nm	50 mm
1.1/2"	305 Nm	55 mm
2"	400 Nm	70 mm

WARRANTY POLICY

WARRANTY REGISTRATION

All machines must be registered, by the selling dealer with McConnel Ltd, before delivery to the end user. On receipt of the goods it is the buyer's responsibility to check that the Verification of Warranty Registration in the Operator's Manual has been completed by the selling dealer.

1. LIMITED WARRANTIES

- 1.01. *All mounted machines supplied by McConnel Ltd are warranted to be free from defects in material and workmanship from the date of sale to the original purchaser for a period of 12 months, unless a different period is specified.
All Self Propelled Machines supplied by McConnel Ltd are warranted to be free from defects in material and workmanship from the date of sale to the original purchaser for a period of 12 months or 1500 hours. Engine warranty will be specific to the Manufacturer of that unit.*
- 1.02. *All spare parts supplied by McConnel Ltd and purchased by the end user are warranted to be free from defects in material and workmanship from the date of sale to the original purchaser for a period of 6 months. All parts warranty claims must be supported by a copy of the failed part invoice to the end user. We cannot consider claims for which sales invoices are not available.*
- 1.03. *The warranty offered by McConnel Ltd is limited to the making good by repair or replacement for the purchaser any part or parts found, upon examination at its factory, to be defective under normal use and service due to defects in material or workmanship. Returned parts must be complete and unexamined. Pack the component(s) carefully so that any transit damage is avoided. All ports on hydraulic items should be drained of oil and securely plugged to prevent seepage and foreign body ingress. Certain other components, electrical items for example, may require particular care when packing to avoid damage in transit.*
- 1.04. *This warranty does not extend to any product from which McConnel Ltd's serial number plate has been removed or altered.*
- 1.05. *The warranty policy is valid for machines registered in line with the terms and conditions detailed and on the basis that the machines do not extend a period of 24 months or greater since their original purchase date, that is the original invoice date from McConnel Limited.
Machines that are held in stock for more than 24 months cannot be registered for warranty.*
- 1.06. *This warranty does not apply to any part of the goods, which has been subjected to improper or abnormal use, negligence, alteration, modification, fitment of non-genuine parts, accident damage, or damage resulting from contact with overhead power lines, damage caused by foreign objects (e.g. stones, iron, material other than vegetation), failure due to lack of maintenance, use of incorrect oil or lubricants, contamination of the oil, or which has served its normal life. This warranty does not apply to any expendable items such as blades, belts, clutch linings, filter elements, flails, flap kits, skids, soil engaging parts, shields, guards, wear pads, pneumatic tyres or tracks.*
- 1.07. *Temporary repairs and consequential loss - i.e. oil, downtime and associated parts are specifically excluded from the warranty.*
- 1.08. *Warranty on hoses is limited to 12 months and does not include hoses which have suffered external damage. Only complete hoses may be returned under warranty, any which have been cut or repaired will be rejected.*
- 1.09. *Machines must be repaired immediately a problem arises. Continued use of the machine after a problem has occurred can result in further component failures, for which McConnel Ltd cannot be held liable, and may have safety implications.*
- 1.10. *If in exceptional circumstances a non McConnel Ltd part is used to effect a repair, warranty reimbursement will be at no more than McConnel Ltd's standard dealer cost for the genuine part.*

- 1.11. *Except as provided herein, no employee, agent, dealer or other person is authorised to give any warranties of any nature on behalf of McConnell Ltd.*
- 1.12. *For machine warranty periods in excess of 12 months the following additional exclusions shall apply:*
 - 1.12.1. *Hoses, exposed pipes and hydraulic tank breathers.*
 - 1.12.2. *Filters.*
 - 1.12.3. *Rubber mountings.*
 - 1.12.4. *External electric wiring.*
 - 1.12.5. *Bearings and seals*
 - 1.12.6. *External Cables, Linkages*
 - 1.12.7. *Loose/Corroded Connections, Light Units, LED's*
 - 1.12.8. *Comfort items such as Operator Seat, Ventilation, Audio Equipment*
- 1.13. *All service work, particularly filter changes, must be carried out in accordance with the manufacturer's service schedule. Failure to comply will invalidate the warranty. In the event of a claim, proof of the service work being carried out may be required.*
- 1.14. *Repeat or additional repairs resulting from incorrect diagnosis or poor quality previous repair work are excluded from warranty.*

NB Warranty cover will be invalid if any non-genuine parts have been fitted or used. Use of non-genuine parts may seriously affect the machine's performance and safety. McConnell Ltd cannot be held responsible for any failures or safety implications that arise due to the use of non-genuine parts.

2. REMEDIES AND PROCEDURES

- 2.01. *The warranty is not effective unless the Selling Dealer registers the machine, via the McConnell web site and confirms the registration to the purchaser by completing the confirmation form in the operator's manual.*
- 2.02. *Any fault must be reported to an authorised McConnell Ltd dealer as soon as it occurs. Continued use of a machine, after a fault has occurred, can result in further component failure for which McConnell Ltd cannot be held liable.*
- 2.03. *Repairs should be undertaken within two days of the failure. Claims submitted for repairs undertaken more than 2 weeks after a failure has occurred, or 2 days after the parts were supplied will be rejected, unless the delay has been authorised by McConnell Ltd. Please note that failure by the customer to release the machine for repair will not be accepted as a reason for delay in repair or submitting warranty claims.*
- 2.04. *All claims must be submitted, by an authorised McConnell Ltd Service Dealer, within 30 days of the date of repair.*
- 2.05. *Following examination of the claim and parts, McConnell Ltd will pay, at their discretion, for any valid claim the invoiced cost of any parts supplied by McConnell Ltd and appropriate labour and mileage allowances if applicable.*
- 2.06. *The submission of a claim is not a guarantee of payment.*
- 2.07. *Any decision reached by McConnell Ltd. is final.*

3. LIMITATION OF LIABILITY

- 3.01. *McConnell Ltd disclaims any express (except as set forth herein) and implied warranties with respect to the goods including, but not limited to, merchantability and fitness for a particular purpose.*
- 3.02. *McConnell Ltd makes no warranty as to the design, capability, capacity or suitability for use of the goods.*
- 3.03. *Except as provided herein, McConnell Ltd shall have no liability or responsibility to the purchaser or any other person or entity with respect to any liability, loss, or damage caused or alleged to be caused directly or indirectly by the goods including, but not limited to, any indirect, special, consequential, or incidental damages resulting from the use or operation of the goods or any breach of this warranty. Notwithstanding the above limitations and warranties, the manufacturer's liability hereunder for damages incurred by the purchaser or others shall not exceed the price of the goods.*
- 3.04. *No action arising out of any claimed breach of this warranty or transactions under this warranty may be brought more than one (1) year after the cause of the action has occurred.*

4. MISCELLANEOUS

- 4.01. McConnel Ltd may waive compliance with any of the terms of this limited warranty, but no waiver of any terms shall be deemed to be a waiver of any other term.*
- 4.02. If any provision of this limited warranty shall violate any applicable law and is held to be unenforceable, then the invalidity of such provision shall not invalidate any other provisions herein.*
- 4.03. Applicable law may provide rights and benefits to the purchaser in addition to those provided herein.*

McConnel Limited



For Safety and Performance...

ALWAYS READ THE BOOK FIRST



McCONNEL LIMITED

**Temeside Works
Ludlow
Shropshire
England**

**Telephone: +44 (0)1584 873131
www.mcconnel.com**

**This manual must be read and used in conjunction with:
ROBOCUT Operation Manual**

Robocut operation manuals are available on our website via the links below;



In line with our policy of constant improvement this publication may be periodically updated. To ensure you have access to the latest version of this manual please visit the manuals library on our website where an up-to-date version can be referenced online or downloaded.

To access manuals use the QR code opposite or the web address below;

<https://my.mcconnel.com/service/pdf-manuals/pdf-operator-manuals/remote-control-technology-manuals/>

CONTENTS

General Information	1
Introduction	2
Machine Identification	2
Technical Specifications	3
Machine Overview	4
Safety Information.....	5
Safety Decals.....	8
Attaching the machine	9
Hydraulic connections.....	11
Expansion vessel.....	11
Machine removal	11
Front hood	14
Machine set-up & adjustment	15
Lateral supports	15
Skids adjustment	15
Push bar adjustment.....	15
Operation	16
Pre-operational checks	16
Transport	16
Pre-work	16
Starting work.....	16
Working speed.....	16
Operating position & distance.....	17
Working on slopes	17
Maintenance	18
Daily maintenance	18
Grease points	18
Identification of rotor components.....	19
Rotor vibration	19
Drive belts.....	20
Belt checking	20
Belt tension setting	20
Belt tension adjustment.....	20
Belts replacement.....	21
Belt pulley alignment.....	22
Taperlocks	22
Machine storage	23
Troubleshooting chart.....	24

GENERAL INFORMATION

Read this manual before fitting or operating the machine or accessory. Whenever any doubt exists contact your local dealer or the McConnell Service Department for assistance.

Only use 'Genuine McConnell Parts' on McConnell machinery and equipment.

DEFINITIONS: *The following definitions apply throughout this manual;*

⚠ DANGER

DANGER: Alerts to a hazardous situation which will result in death or serious injury if not observed carefully.

⚠ WARNING

WARNING: Alerts to a hazardous situation which could result in death or serious injury if not observed carefully.

⚠ CAUTION

CAUTION: Alerts to a hazardous situation which could result in damage to the machine and/or equipment if not observed carefully.

NOTICE

NOTICE: Specific or general information considered important or useful to emphasise.

LEFT HAND (LH) & RIGHT HAND (RH): *These terms are applicable to the machine when fitted to the tractor and viewed from the rear; these terms also apply to tractor references.*

SERIAL PLATE

All machines are equipped with a serial number plate containing important information relating to the machine including a unique serial number used for identification purposes.

Note: Images in this manual are provided for instruction and informational purposes only and may not show components in their entirety. In certain instances images may appear different to the actual machine; where this occurs the general procedure will be basically the same. E&OE.

NOISE LEVEL

L_{pA}
99

L_{pA} = the value indicates the maximum sound level perceived by the operator at a distance of 1 metre from the machine.

L_{wA}
105

L_{wA} = the value indicates the sound level outside the machine and refers to the noise perceived by those who are in the vicinity of the work area.

INTRODUCTION

The Robo-Forest and Robo-Mulcher machines are 1.3m & 1.6m ultra-heavy-duty flailhead attachments for use on McConnel all-terrain remote control Robocut machines with the option of a 60HP or 75HP motor.

All models feature a hydraulic front hood and reinforced steel push bar to aid the feeding of material into the machine.

Robo-Forest heads are equipped with a heavy-duty steel rotor armed with hard-wearing tungsten carbide teeth. The rotor, which spins at 2800rpm, is capable of 'tearing' through a wide range of wooded growth materials from saplings to tree stumps and can mulch down materials up to 100mm thick.

The Robo-Mulcher head offers similar performance using heavy-duty swinging hammer flails attached to a specially designed rotor that provides exceptional cutting momentum for pounding overgrowth and debris into a fine mulch.

These machines are ideal tools for use in the forestry industry and/or for contractors operating in dense overgrowth on difficult terrain or in areas where access is limited.

These machines should only be used to perform tasks for which they are designed; use of the machines for any other function can be dangerous to persons and damaging to components.



MACHINE IDENTIFICATION

Machines are fitted with an identification plate containing information that can be used to identify your exact machine and model.

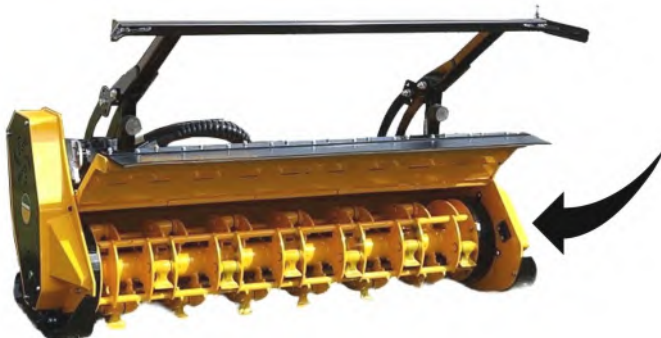

Always quote details from this identification plate when ordering replacement parts and/or seeking service information or advice.

TECHNICAL SPECIFICATIONS

DIMENSIONS	1300 Models	1600 Models
Working width	1350mm	1650mm
Maximum width	1550mm	1850mm
Maximum depth	800mm	800mm
Maximum height	1100mm	1100mm

SPECIFICATIONS – 1300 Models (60HP)	ROBO-MULCHER	ROBO-FOREST
Machine part number	4060140	4060145
Rotor speed (maximum)	2800rpm	2800rpm
Rotor tools (type)	Hammer Flail	Fixed Tooth
Rotor tools (quantity)	20	56
Motor power	60HP	60HP
Machine weight	460kg	464kg

SPECIFICATIONS – 1300 Models (75HP)	ROBO-MULCHER	ROBO-FOREST
Machine part number	4080140	4080145
Rotor speed (maximum)	2800rpm	2800rpm
Rotor tools (type)	Hammer Flail	Fixed Tooth
Rotor tools (quantity)	20	56
Motor power	75HP	75HP
Machine weight	476kg	471kg

SPECIFICATIONS – 1600 Models (60HP)	ROBO-MULCHER	ROBO-FOREST
Machine part number	4060141	4060146
Rotor speed (maximum)	2800rpm	2800rpm
Rotor tools (type)	Hammer Flail	Fixed Tooth
Rotor tools (quantity)	24	68
Motor power	60HP	60HP
Machine weight	488kg	503kg

SPECIFICATIONS – 1600 Models (75HP)	ROBO-MULCHER	ROBO-FOREST
Machine part number	4080141	4080146
Rotor speed (maximum)	2800rpm	2800rpm
Rotor tools (type)	Hammer Flail	Fixed Tooth
Rotor tools (quantity)	24	68
Motor power	75HP	75HP
Machine weight	495kg	510kg

Handling the Machine

Handling of the machine should be performed using suitable overhead lifting equipment. Equipment used must have a minimum safe lifting capacity over and above the maximum weight of the machine. Ensure the machine is balanced during the lifting procedure and that all bystanders are kept clear of the raised machine.

The machine must always be parked or stored on a firm level surface.

⚠ WARNING Keep all persons clear of the machine during the lifting procedure.

⚠ CAUTION Never attach lifting equipment to the push bar to raise the machine.

MACHINE OVERVIEW

Component Identification / Location

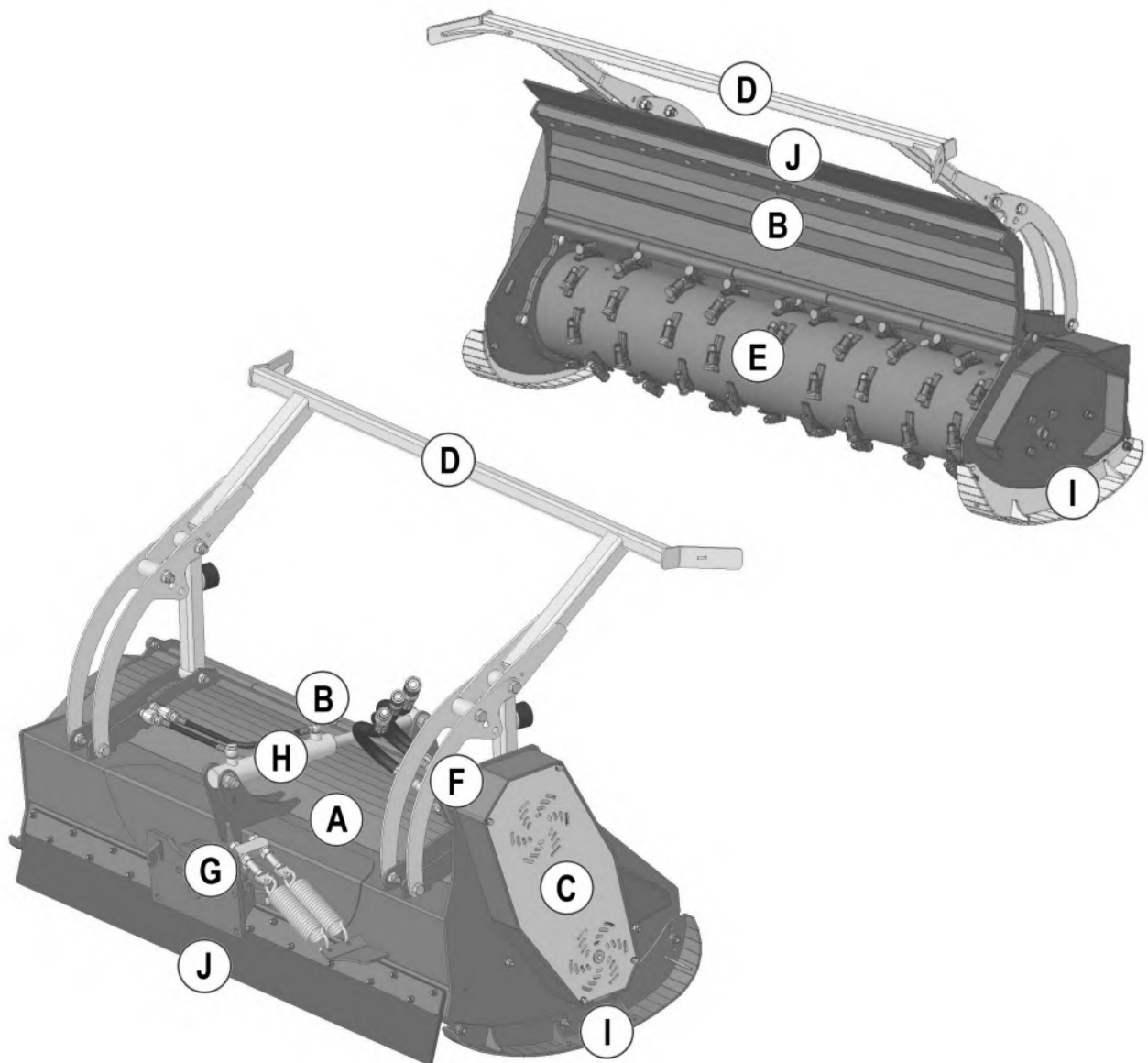

- | | |
|-----------------------|-----------------------------|
| A) Casing | F) Hydraulic Motor |
| B) Front Hood | G) Mounting Assembly |
| C) Belt Drive Housing | H) Hood Ram |
| D) Push Bar | I) Side Skids |
| E) Rotor | J) Rubber Protection Guards |



Read the safety information for all machinery you are operating

This machine has the potential to be extremely dangerous - in the wrong hands it can kill or maim; It is therefore imperative that both owner and operator of the machine reads the following section to ensure they are fully aware of the dangers that do, or may exist, and fully understand their responsibilities surrounding use and operation of this machinery.

Although this safety advice covers some aspects of the Robocut machine, all users must also read and understand the Robocut operation manual fully before using this machinery. The operator of this machine is responsible not only for their own safety but equally for the safety of all others who may come into the close proximity of the machine, as the owner you are responsible for both.

When the machine is not in use it should be parked or stored on a firm level site.

In the event of any fault being detected with the machine's operation it must be stopped immediately and not used again until the fault has been corrected by a qualified technician.

- ⚠ Before starting the machine the operator must read and understand all aspects of use and maintenance of the machine as stated in this manual.*
- ⚠ The machine must only be used by a responsible adult who is familiar with all aspects relating to safe operation. Certificated training may be required on certain sites.*
- ⚠ The machine must not be operated by children or non-authorised persons.*
- ⚠ Operators must know the meaning of all operation and safety decals on the machinery and control units being operated.*
- ⚠ Operators must know the correct procedure for switching the machine off and know the locations of all Emergency Stop buttons.*
- ⚠ Do not attempt to use the machine if any of the Emergency Stop buttons are damaged or malfunctioning.*
- ⚠ Never use the machine with safety guarding removed or defective.*
- ⚠ Operators should practice operation on flat open ground to familiarise themselves with driving and manoeuvring the machinery before attempting to use it on sloping ground.*
- ⚠ Operators should practice manoeuvring the machinery around obstacles, without the mounted equipment running, before using the machine for work purposes.*
- ⚠ Never operate the machine if your vision is blocked or obscured by obstacles such as vehicles, buildings, hedges, fences etc.; move to a safe position where you have a clear, un-interrupted view of the entire machine.*

- ⚠ Never operate the machine when standing directly in the line of travel.*
- ⚠ Do not use the machine on sand piles, gravel, or other similar loose materials.*
- ⚠ Only operate the machine in good visibility.*
- ⚠ Never start or run the machinery in an enclosed area or building.*
- ⚠ Keep the machine clean to avoid build ups of dry materials that could ignite on hot components.*
- ⚠ Never stand directly below a machine that is working or parked on a slope.*
- ⚠ Always operate the joystick control slowly; rapid or jerky movements could cause the machine to 'rear up' causing loss of control.*
- ⚠ When operating the machine with the head unit running the operator must remain in a safe position at least 5 metres away from the machine; always switch the head unit off before approaching the machinery.*
- ⚠ When using the machine the operator should place themselves in a position that provides optimum visibility over the entire work area.*
- ⚠ Never leave a running machine unattended; always switch the engine off and remove the isolator key.*
- ⚠ Always stop and switch the machine off if persons or animals enter the work area; do not restart the machine until they are at a safe distance.*
- ⚠ Never use the machine to perform tasks it was not designed for.*
- ⚠ Never ride or allow others to ride on the machine.*
- ⚠ Always inspect the work area prior to operation and remove stones, glass, metal, wire or any other foreign objects that are hazardous. Immovable hazards should be suitably 'marked' so they can be easily avoided.*
- ⚠ Take extra care when operating the machine on slopes or uneven ground; there is increased risk of objects being thrown from rotating equipment when working in these conditions.*
- ⚠ The machine can be used on slopes up to a maximum of 55° (track option dependant) providing the surface is dry and firm.*
- ⚠ Should a machine overturn, a suitable crane or winch should be used to recover it; keep all persons at a safe distance before and during recovery.*
- ⚠ Do not operate the machine in foggy or frosty conditions as there is increased risk of accidents.*
- ⚠ Take extra care when working in close proximity to electrical cables; in some circumstances, operating the machine under overhead power lines can result in loss of radio signal causing the engine of the Robocut to be deactivated.*
- ⚠ Do not operate the machine close to vehicles or properties where there is possible risk of damage by objects that could be accidentally ejected from the machine.*
- ⚠ It is the user's responsibility to protect persons and animals in or near the work zone.*
- ⚠ When servicing or maintaining the machinery no-one should be allowed beneath it when it is raised unless it is securely supported on suitable ramps and/or stands.*
- ⚠ Never attempt to service or maintain the machinery whilst it is running; always switch off the engine and remove the isolator key.*

- ⚠ *When transporting the machinery on another vehicle or trailer the engine must be switched off and the machinery chocked and secured with suitable ropes or chains.*
- ⚠ *Check the condition of any flails or other mounted tools and their fixings on a regular basis; never use a machine with damaged or missing flails/tools or loose fixings.*
- ⚠ *Always clean the machine after use; if machine components are hot allow them to cool to a safe temperature before cleaning. Never use solvent based chemicals for cleaning.*
- ⚠ *When operating in excessively dusty conditions the machine may need to be stopped on a regular basis to remove any build ups of dust on components that could cause overheating; switch the engine off and beware of hot components.*
- ⚠ *Ensure engine is switched off and Emergency Stop switch is in the 'off' position before refuelling.*
- ⚠ *Wherever possible refuel the machine before work when the engine is cold. If refuelling during work, switch off the engine and allow it to cool before adding fuel.*
- ⚠ *Test the Emergency Stop buttons before each period of work to ensure they function correctly.*
- ⚠ *Never leave the machine, isolator key and control unit unattended in one place; the machine could be started and used by un-authorized persons.*
- ⚠ *Any inspection, service or maintenance of the machine and attached equipment must only be performed with machine switched off and the isolator key removed.*
- ⚠ *Always wear suitable safety gear at all times when performing service or maintenance work on the machine or any mounted equipment.*
- ⚠ *Mounted equipment must always be switched off when manoeuvring outside of the work zone.*

Personal Protective Equipment (PPE)

We recommend that the following personal protective equipment is worn during operation and/or maintenance of this machinery; overalls, safety shoes, safety goggles, ear protection, safety helmet, protective gloves, respiratory protection, shin/knee protection.



Although the information stated here covers a wide range of safety subjects, it is impossible to predict every eventuality that can occur under differing circumstances whilst operating this machine. No advice given here can replace 'good common sense' and 'total awareness' at all times, but it will go a long way towards the safe use of your McConnel machine.



Operating, servicing and maintaining this equipment can expose you to chemicals including gasoline, diesel fuel, lubricants, petroleum products, engine exhaust, carbon monoxide, and phthalates, which are known to the State of California to cause cancer and birth defects or other

reproductive harm. To minimize exposure, avoid breathing exhaust, do not idle the engine except as necessary, service your vehicle in a well-ventilated area and wear gloves or wash your hands frequently when servicing your vehicle. Battery posts, terminals and related accessories contain lead and lead compounds, chemicals known to the state of California to cause cancer, birth defects or other reproductive harm. For more information go to www.P65Warnings.ca.gov. This website, operated by California's Office of Environmental Health Hazard Assessment, provides information about these chemicals and how individuals may be exposed to them.

SAFETY DECALS

The safety decals shown below are displayed on this machine; ensure you understand the meaning of these decals and heed their warning.



1. WARNING!

Switch machines OFF and remove starting key before performing maintenance or servicing.

2. DANGER!

Risk of object ejection – keep clear when machinery is operating or running.

3. DANGER!

Risk of injury - keep clear of rotating blades.

4. DANGER!

Rotating components – keep clear when machinery is operating or running.

5. DANGER!

Do not stand on the machinery during operation or transport.

6. WARNING!

Keep away from the machine when it is operating or running.

All safety decals must be kept in clean readable condition; if any safety decals are missing or become damaged or illegible they should be replaced immediately.

We have a policy of replacing Operator Manuals and Safety Decals free of charge.

ATTACHING THE MACHINE



WARNING

Attachment of the head unit should be performed on a firm level site. Ensure all bystanders are kept at a safe distance from machinery.

DANGER

PINCH POINT

Keep hands clear of potential pinch points when attaching machinery. Suitable personal protection gear should be worn when working with machines.

Attachment Procedure



Tools required; 19mm spanner

1) Position Robocut 'square and central' to the head unit.

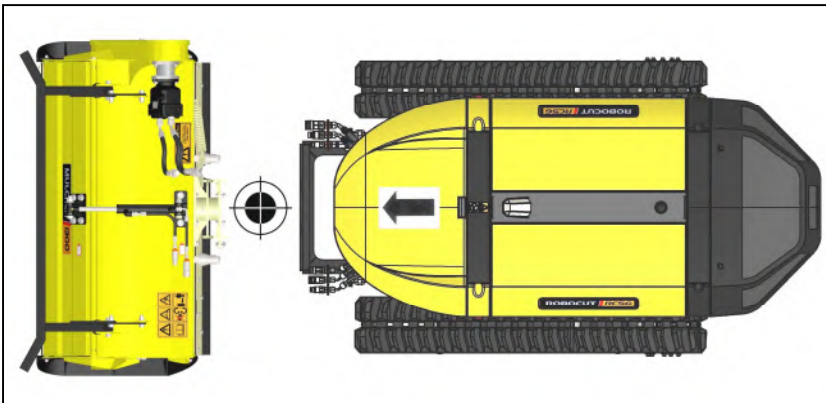

2) Remove head unit fixings.

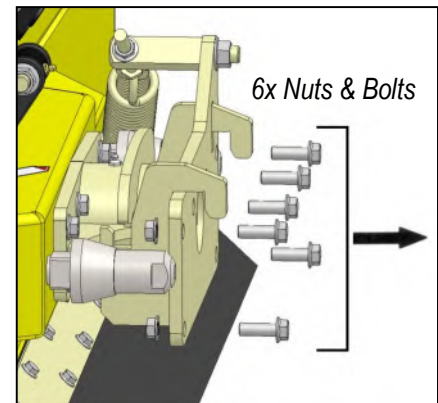

3) Lower Robocut toolbar to a height that is lower than the lugs on head unit mounting bracket.

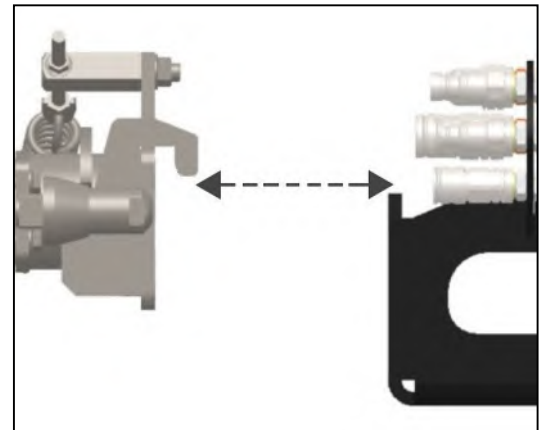
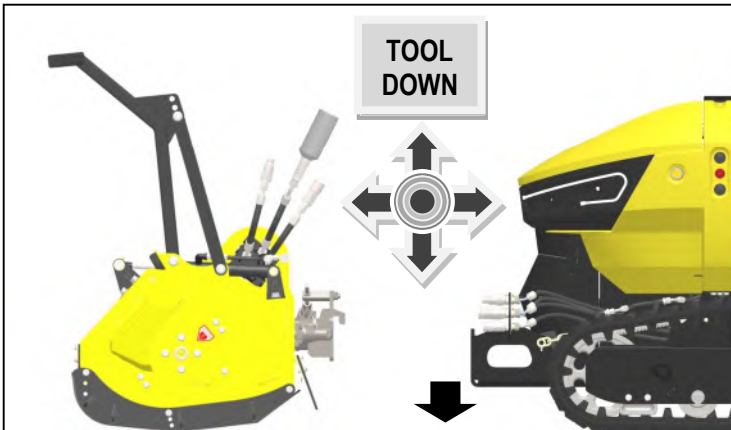

4) Drive Robocut slowly forwards until it is in contact with the flailhead mounting bracket.

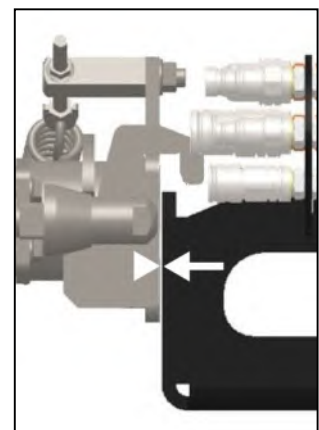
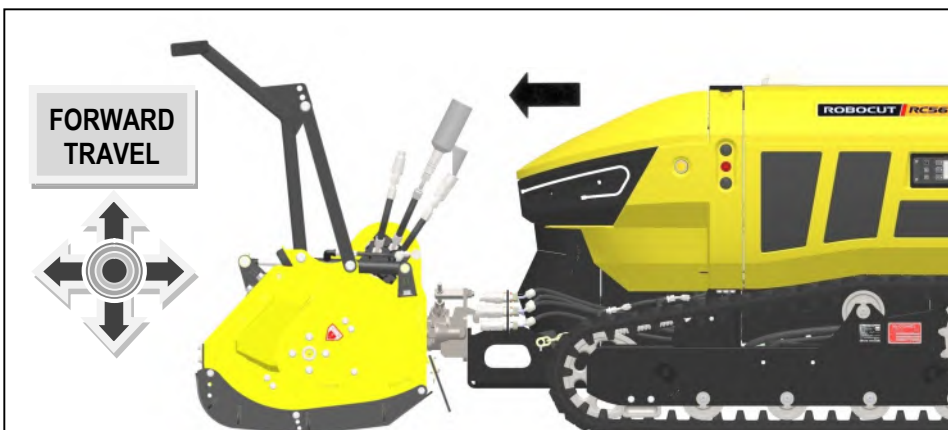

5) Raise Robocut toolbar to connect with lugs on flailhead mounting bracket.

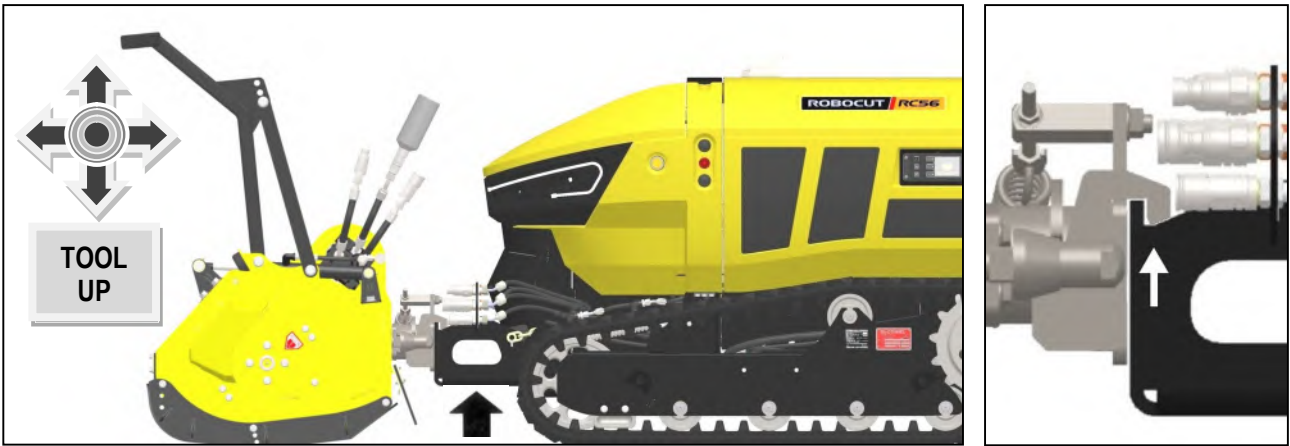

6) Fasten head unit to Robocut toolbar using head unit fixings (6x Nuts & Bolts) - tighten fixings fully.

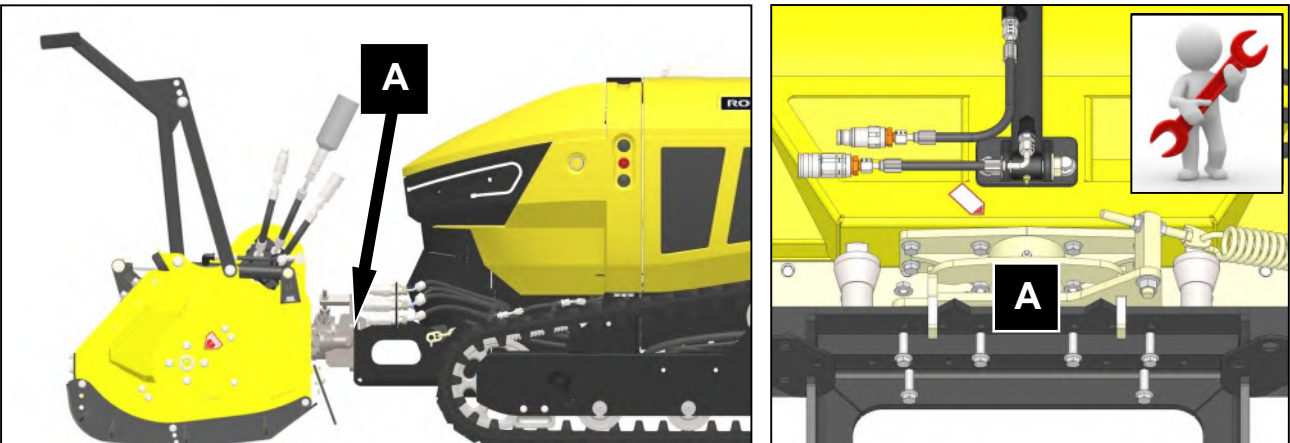

7) Remove expansion vessel from drain line and connect head unit hoses to the Robocut hydraulics.

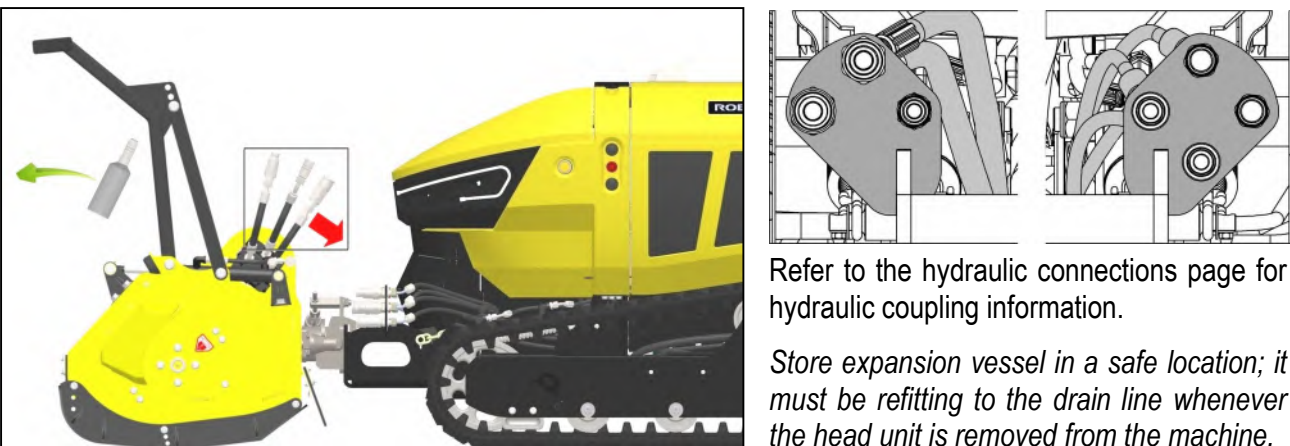

8) Configure the following settings in the Robocut control panel:

Attachment Settings; attachment type & width.



Refer to Robocut operator manual for information on configuring these settings

Float Settings; float calibration (initial install only).

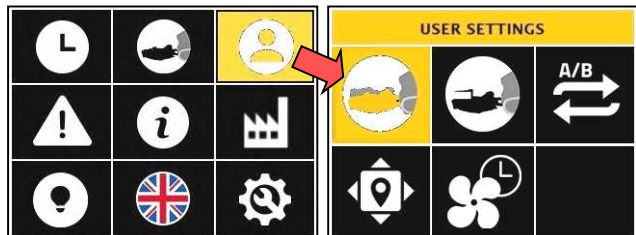

HYDRAULIC CONNECTIONS

Robocut Hydraulic Connection Points

Robocut hydraulic connection points for head unit attachment.

CAUTION Ensure hydraulic couplings on the machine and the attachment are free from dirt or debris – check and clean all couplings prior to connection.

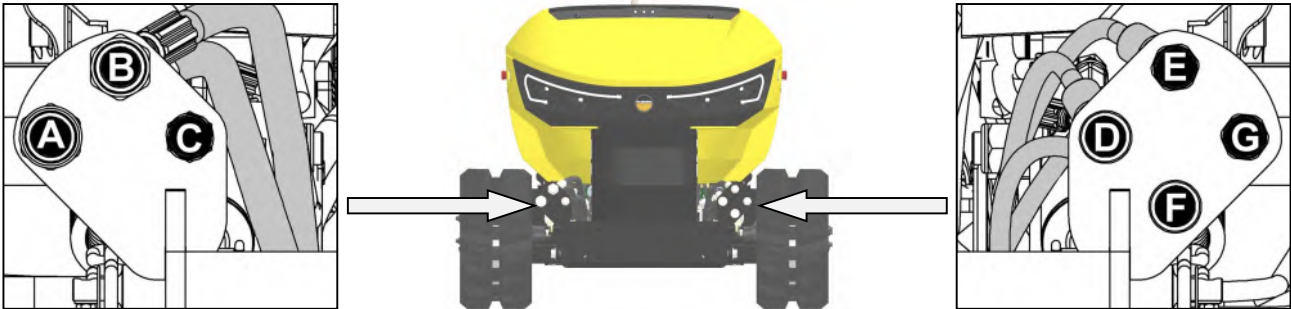

- A. Pressure 'A'
- B. Pressure 'B'
- C. Drain line

When removing head unit from machine ensure that expansion vessel is fitted to the head unit drain line hose.

- D. Hood Ram (Base)
- E. Hood Ram (Gland)
- F. & G. Auxiliary use only

Ensure hydraulic hoses for hood ram are attached to correct connection points (D & E) as indicated in diagram above. Pressure and drain line hoses (A, B & C) can only be attached on their corresponding connections. Connections F & G are reserved for auxiliary use.

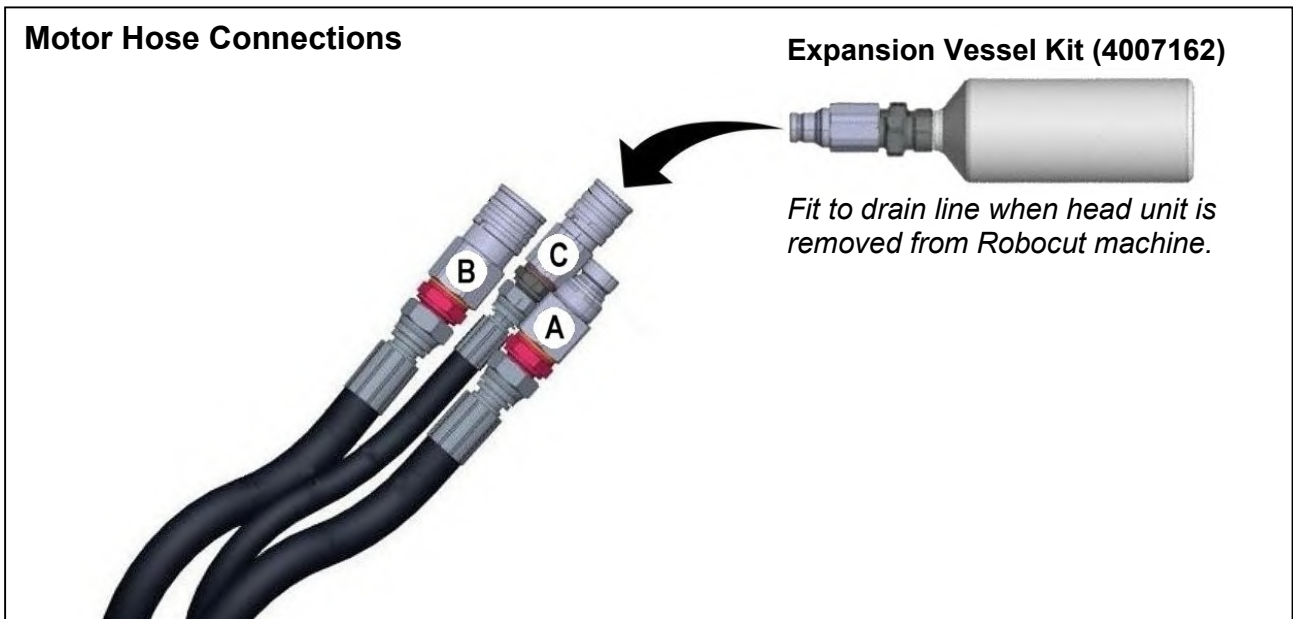

Expansion Vessel – Flail Head Hydraulic Circuit

The heads are provided with an 'expansion vessel' to protect the hydraulic system when the head has been removed from a machine. The expansion vessel attaches to the flail head drain line to permit oil escape for protection of the hydraulic motor's shaft seals; this expansion vessel must always be installed on the flail head when the hydraulic hoses are disconnected.

Machine Removal

Removal of the machine is basically a reversal of the attachment procedure and should be performed on a firm level site.

The expansion vessel must always be installed on the drain line hose when the machines hydraulic connections are disconnected – refer to previous page.

HEAD UNIT CONTROLS

⚠ DANGER

Operators must wear personal safety gear at all times whilst operating the machine and stand in a safe operating position with a clear view of the machinery and the work area.

Robocut Controls Identification for Head Operation

Refer to Robocut manual for full details of machine controls.

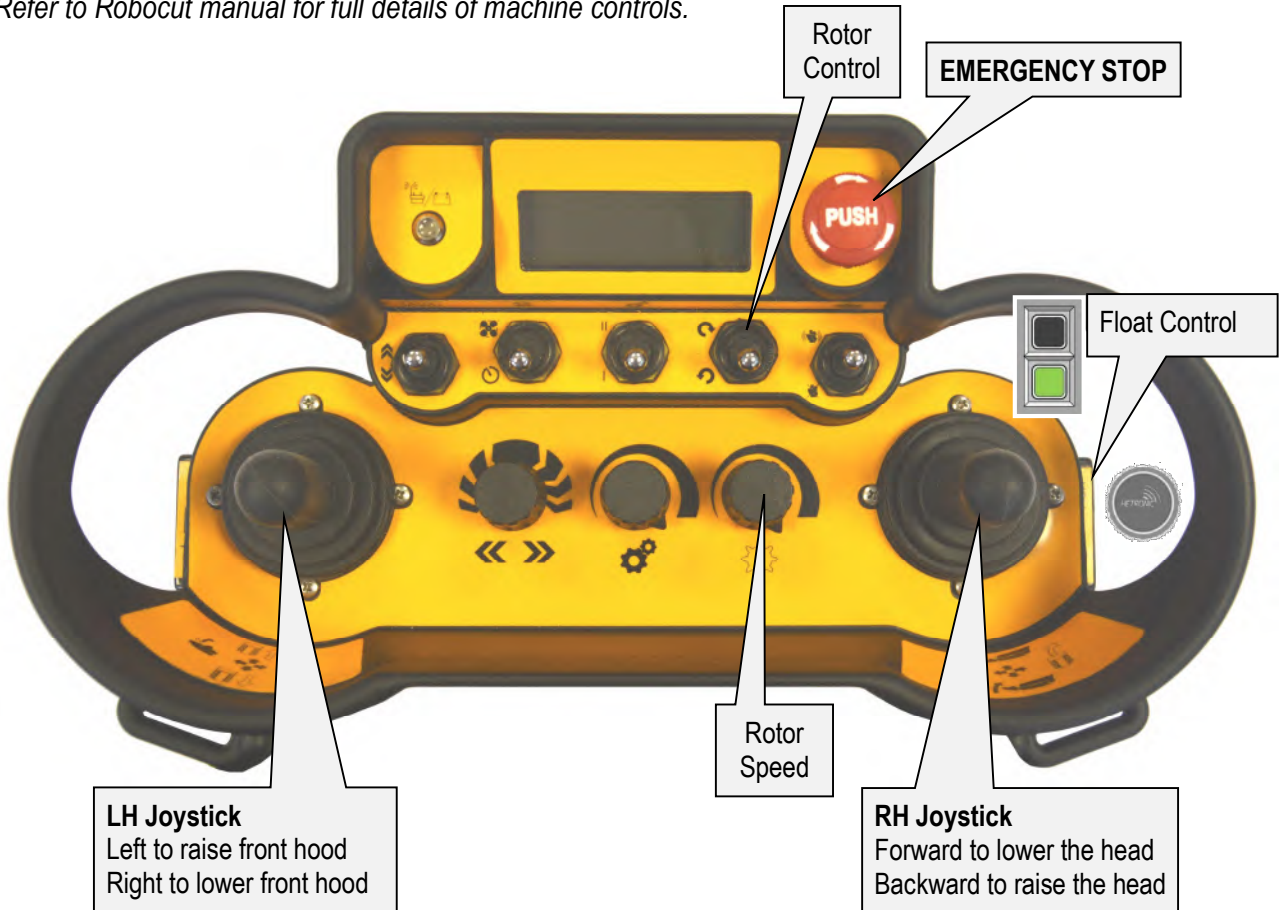

Joystick Controls for Head Operation (Default)

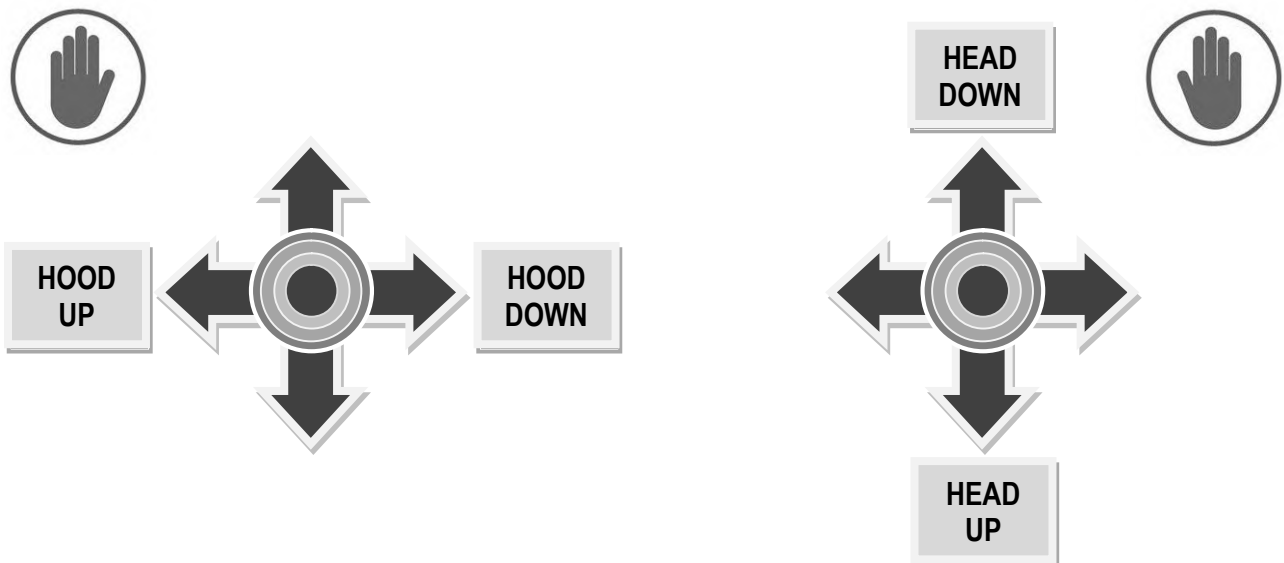

Control Unit – Display Screen & Head Function Operation

LCD Display

Reports the following information;

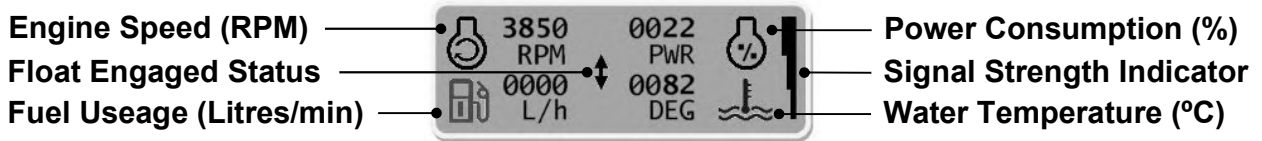

Status Light

Indicates the status of the Remote Control Unit;

Illuminated **GREEN** = 'CORRECT' Status.

Illuminated **RED** = 'PROBLEM' Status.

Emergency Stop Button

'Push' button for 'EMERGENCY STOP'

Rotate clockwise to 'Reset'

Rotor Control Switch

Rotor direction ON and OFF control;



Rotor ON (Uphill): Place switch in 'UP' position to start the rotor 'uphill'



Rotor OFF: Place switch in the central position to 'STOP' rotor



Rotor ON (Downhill): Place switch in 'DOWN' position to start the rotor 'downhill'

Rotor RPM Control Dial (Potentiometer)

Controls the rotor speed;



Increase Rotor RPM: Rotate control dial clockwise

Decrease Rotor RPM: Rotate control dial anti-clockwise



Float Control Button

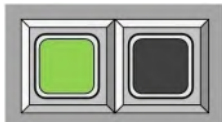

Press **AUX** Button: Activation/deactivation of 'float' feature.



The control information shown in this manual relates to operation of the head unit only; for details of all the controls refer to the Robocut machine operator manual.

FRONT HOOD

The Mulcher and Forest heads are fitted with a hydraulic ram to allow opening of the hinged hood. It should be noted that with the hinged hood open objects could be thrown a considerable distance. Being struck by a thrown object could result in injury or death.

The machine may be operated with the front hood open provided the general safety information and following specific conditions are met;

- A detailed work area and bystander risk assessment is undertaken before work begins.
- The operator has been trained in the safe use of the Robocut.
- All pre-work checks stated in the Robocut manual have been fully performed.

Refer to Robocut operator manual for details.

Hood Operation

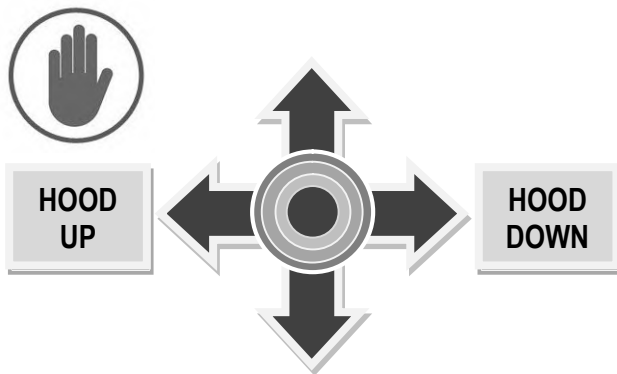

By default, front hood operation is controlled using the left-hand joystick on the Robocut's remote controls; move the joystick to the left to raise the hood and to the right to lower it.

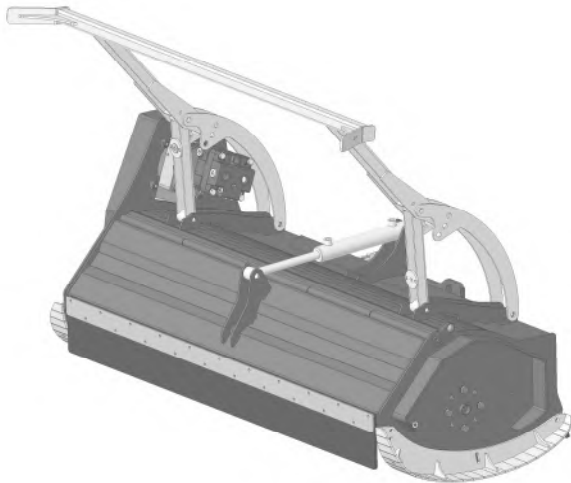

Hood fully closed position

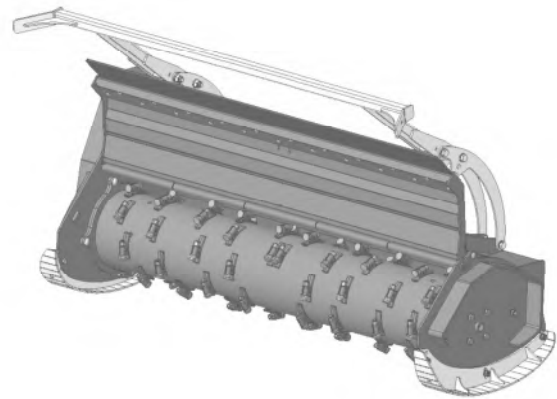

Hood fully open position

The hood is capable of being raised to any position between fully closed and fully open. When operating the machine with the hood open, it should be raised to a suitable position that will allow material to freely enter the head whilst still offering maximum possible protection. Always close the hood fully before stopping the machine.

⚠ DANGER

The machine must only be operated with the hood raised when all safety conditions for working with the machine in this mode have been met.

MACHINE SET-UP & ADJUSTMENT



Machine set-up and adjustments must always be performed on a firm level site with Robocut engine switched off and the starting key removed.

Lateral Supports (Thrust Pins)

The rear casing of the machine is fitted with thrust pins on each side of its mounting; these are to provide lateral support in the event of accidental impact, thus reducing stress on the central mounting point.

When mounting the machine, the thrust pins must be adjusted to place them in touch contact with the Robocut's frontal mounting plate. Adjustment is performed by rotating the pins to extend them until they are in contact with the mounting plate.

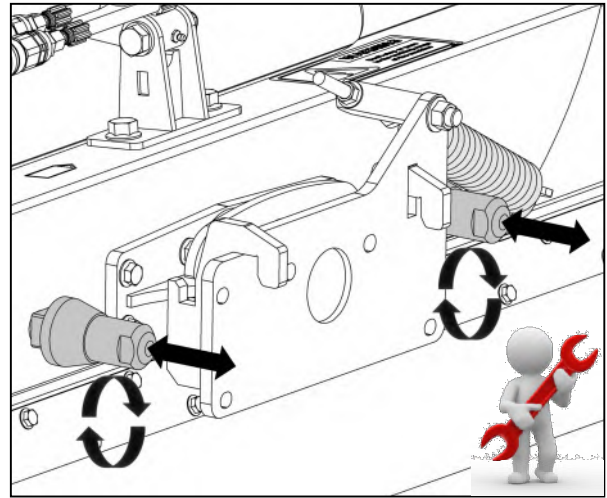

Skids Adjustment

Machines are equipped with adjustable skids on each side of the machine which can be set at any one of 3 height positions; *the height setting selected determines the cutting height of the rotor.*

To adjust the skid height, rear and mid position bolts 'A' & 'B' must be slacked off and frontal bolt 'C' removed; this will allow the front of the skid to be pivoted into a higher or lower position. With required height setting selected, replace bolt 'C' before fully tightening all 3 bolts. Repeat the procedure on the opposing skid ensuring same height position is selected.

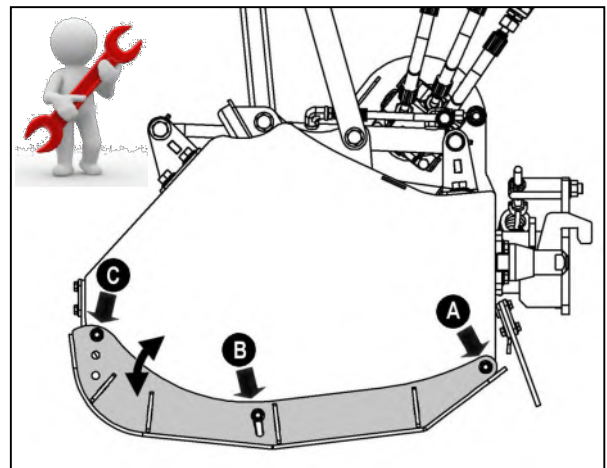

Never attempt to use machine with side skids removed; flails should not be allowed to contact the ground.



Do not attempt to adjust skid heights whilst the machine is running.

Push Bar Adjustment

Machines are equipped with a push bar; this aids the feeding of material into the machine by forcing it forward and downward ahead of the rotor. The position of the push bar can be adjusted to suit the requirement of the job.

Adjustment of the push bar is achieved by removal of the nuts and bolts from the upper positions of the support bars and replacing them in alternate hole positions to alter the work angle.

Ensure when replacing fixings that the same hole position is selected on each support.

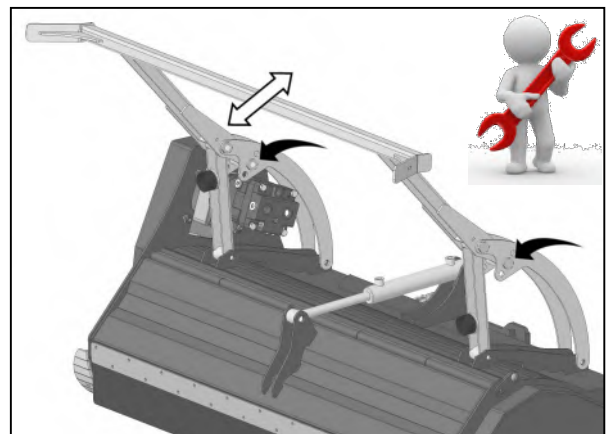

OPERATION



All operators must be suitably qualified to use a machine of this nature and must fully read and understood all manuals for the machinery being used - they must be aware of all safety aspects relating to safe use of the machinery they are operating.

It is advisable that all 'first time' operators practice using the machinery in a clear safe area prior to work in order to familiarise themselves with its operation.

After the initial first 2 hours of work with a new machine, nuts and bolts should be checked for tightness and retightened if required.

Pre-Operational Checks

Before commencing work with the machine, the following checks should be performed;

- Make a visual inspection of the machine to ensure it is in good operational condition.
- Check all safety guarding is in position and in full working order.
- Check rotor for missing or damaged teeth/flails and replace if required.
- Check all greasing points are well lubricated.
- Check belt tension and adjust if required.

Transport

The following must always be observed when transporting the machine;

- Machine must be switched off.
- Machine must be raised to a suitable transportation height.

Pre-Work

Prior to starting work, the area should be checked for dangerous objects such as large stones, wire, glass etc. and any hazardous objects removed from the area prior to operation with the machine. The location of unmovable or natural hazards should be noted, or if necessary 'marked' to indicate to the operator that the area should be avoided or additional caution adopted whilst working around the hazard.

Starting Work

With the machine switched off, lower it into a position approximately 10cm above the ground, start the machine and allow it to build up to the correct working speed before gently lowering it to rest on the ground - the machine is now in its working position and forward travel into the work can begin.

Working Speed

The working speed will depend on the working conditions and nature of the material being cut, in all conditions speed should be kept to a pace at which the machine efficiently cuts and mulches the material.

Never operate at speeds that do not permit the operator enough time to avoid potential dangers or hazards or at speeds that place undue stress on the machine or its components.

Operating Position & Distance

Only operate the machine from a safe distance and position that provides an unobstructed view of the machine and work area. When operating this machinery, you are responsible for your own safety and the safety of all others who enter the work area.

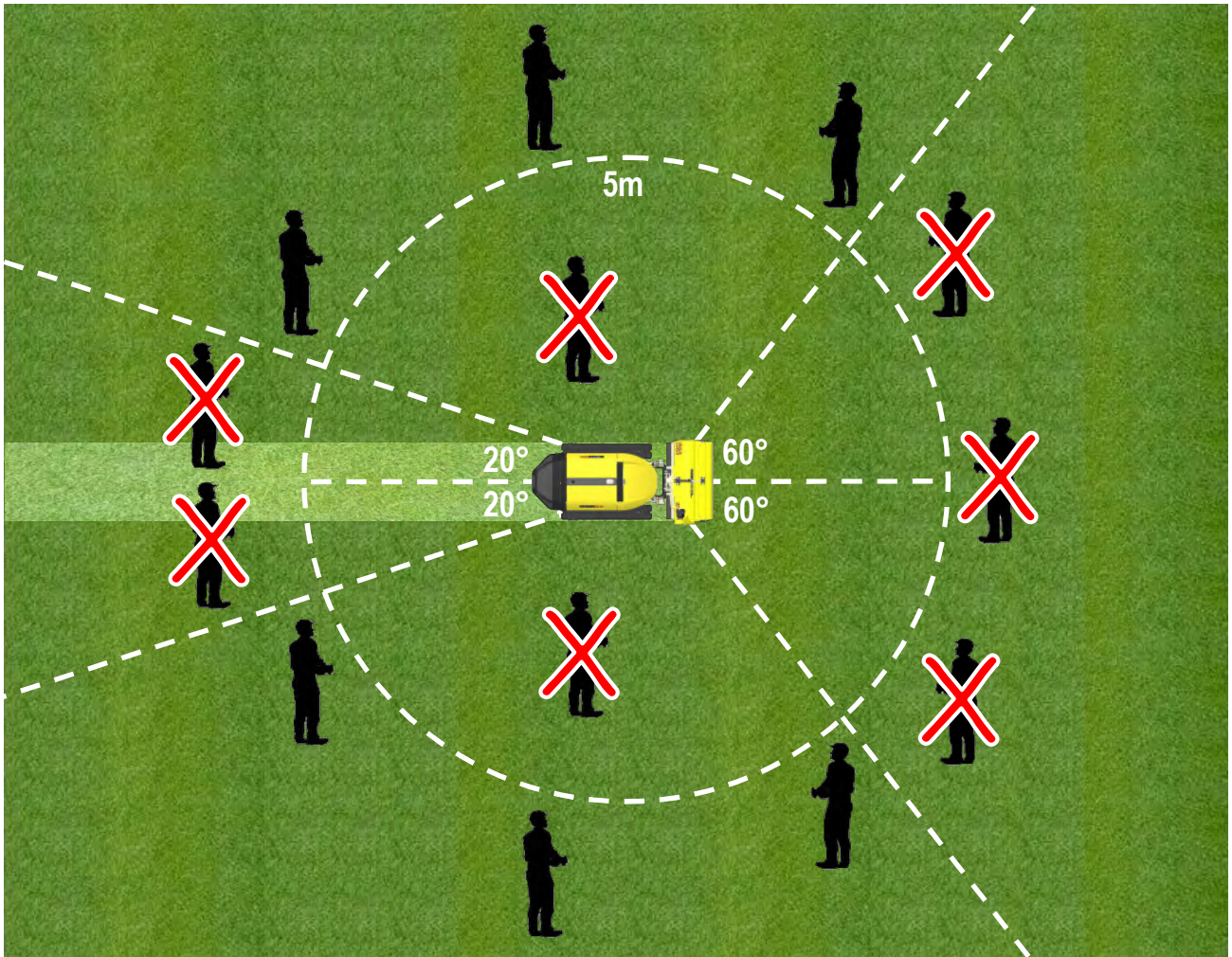

Working on Slopes

When working on slopes do not operate from any position directly below the machine, where possible it is safer to stand in a suitable location above the machine.

⚠ WARNING Do not operate the machine on ground or surfaces that are slippery underfoot.

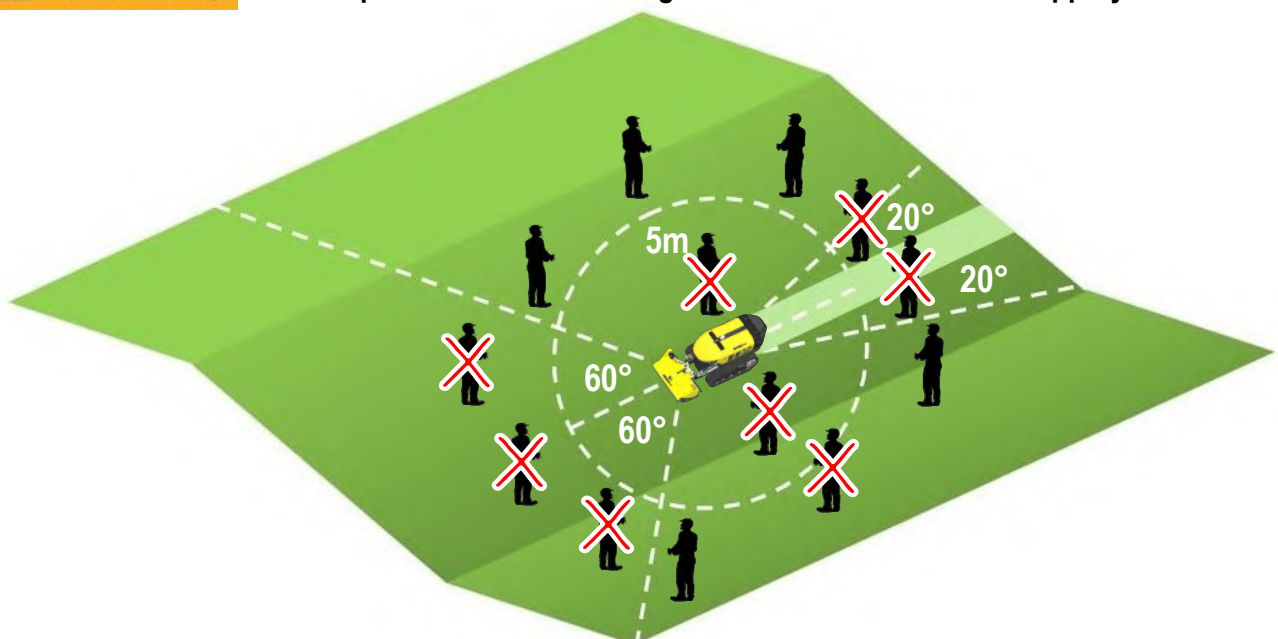

MAINTENANCE

Daily Maintenance

- Lubricate the machine at the frequency stated on the grease point decals.
- Inspect rotor for signs of missing, damaged or worn components.
- Check tightness of all fixings.
- Check hydraulic system for signs of leaks, wear or damage.
- Check condition of safety guards/covers.
- Inspect the machine to verify there are no signs of cracks on welds.

Grease Points

Lubricate the locations indicated below at the frequency stated on the grease point decal.

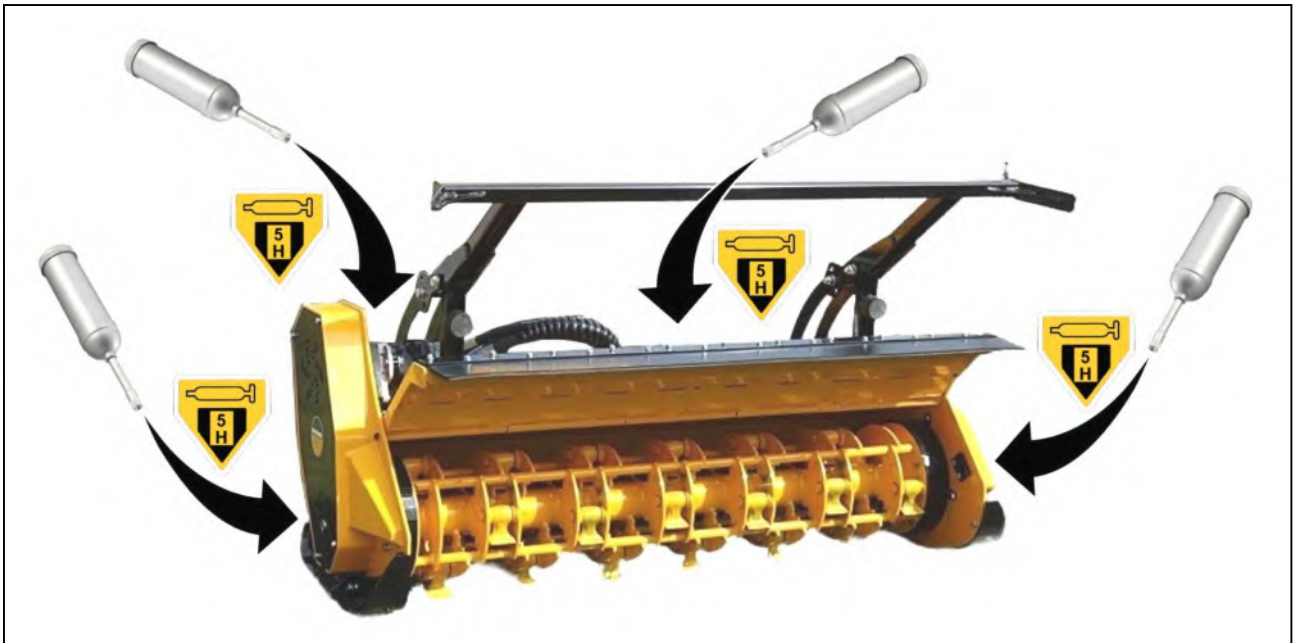

Inspection/Replacement of Rotor Tools

It is important to inspect the rotor tools on a daily basis for signs of excessive wear and/or damage.

Rotor tools must be replaced immediately if excessive wear or damage is detected; failure to observe this could result in damaged components being ejected from the machine at high speed if they break. This can cause severe damage to the machine and/or serious injury or death.

On Mulcher machines, if only one hammer needs replacing it is advisable to also replace the hammer on the opposing side of the rotor to retain rotor balance. Torque hammer bolts to **180 Nm**.

Hammers must be replaced immediately if:

- Twisted or deformed
- Bolt hole is worn
- Have visible cracks
- Have deep indentations on the surface
- Have a badly worn or damaged cutting edge

When replacing rotor tools, always fit genuine service parts.

Identification of Mulcher Head Rotor Components

Flail Kit (4007181)

1. Flail (1840572)
2. Bolt (7390006)
3. Nut (0141006)
4. Spring Washer (0100207)
5. Bush (21215.02)

1300 Model = 20 sets per rotor

1600 Model = 24 sets per rotor

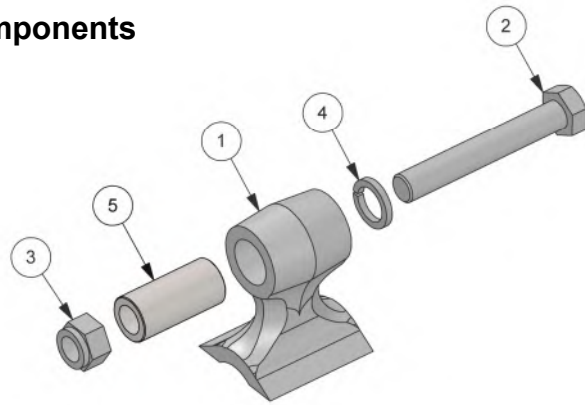

Torque nuts to 180Nm (133 ft-lb)

Identification of Forestry Head Rotor Components

Forestry Tooth & Nut

1. Tooth (4007202)
2. Nut (4007224)

1300 Model = 56 sets per rotor

1600 Model = 68 sets per rotor

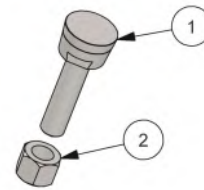

Torque nuts to 180Nm (133 ft-lb)

Rotor Vibration

If vibration of the rotor is experienced the machine should be stopped immediately, this is often a sign that a flail is either missing or severely damaged, if this is the case do not use the machine until the problem has been rectified. If vibration continues, or occurs for no apparent reason, the rotor must be checked and if necessary rebalanced before using the machine again. Contact your local dealer for further advice or assistance on this subject.

Drive Belts

The drive belts on the machine provide transfer of power from the hydraulic motor to the rotor; if an obstruction is encountered or the machine is severely overloaded components are protected by a relief valve located within the motor.

Access to the belt system is gained by removal of the belt cover which is secured with 4 screws.

⚠ WARNING

Never attempt to start or run the machine with the belt cover removed.

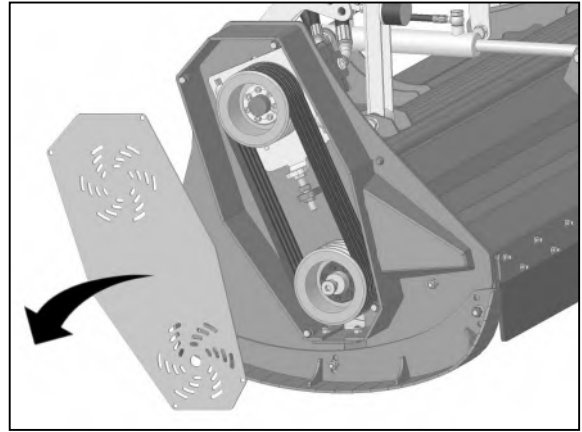

Belt Checking

Drive belts should be inspected for signs of wear or damage and the tension checked on a regular basis. Belts should always be checked prior to operation.

Damaged or badly worn belts must be replaced immediately; when fitting new belts always fit a complete set. Tension should be re-checked after the initial first hour or so of work.

Belt Tension Setting

Belt tension is correct when they deflect 15mm under a force of 10kg applied at midway point between the pulleys.

Belt Tension Adjustment

For belt tension adjustment the machine should be parked up resting on firm level ground with the hydraulic hoses disconnected.



Tools required; 13mm,19mm & 22mm spanner or socket, belt tension gauge.

The tension adjustment procedure is as follows;

1. Remove belt cover to permit access to belt adjuster, this is located on the back plate between the belt drive pulleys.

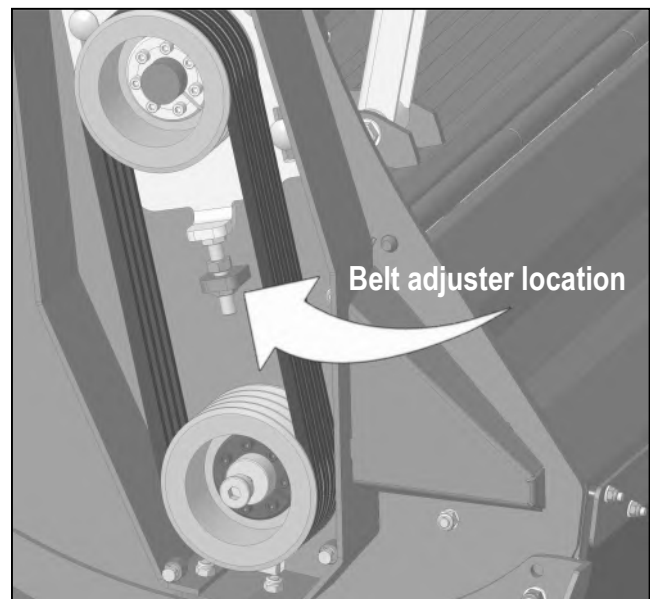
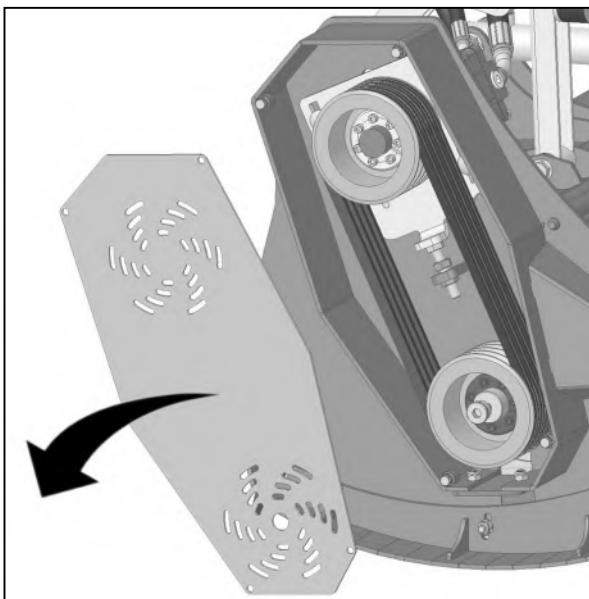

2. Slacken nuts on motor mounting block; only slacken nuts sufficient to allow the adjustment plate freedom to move.

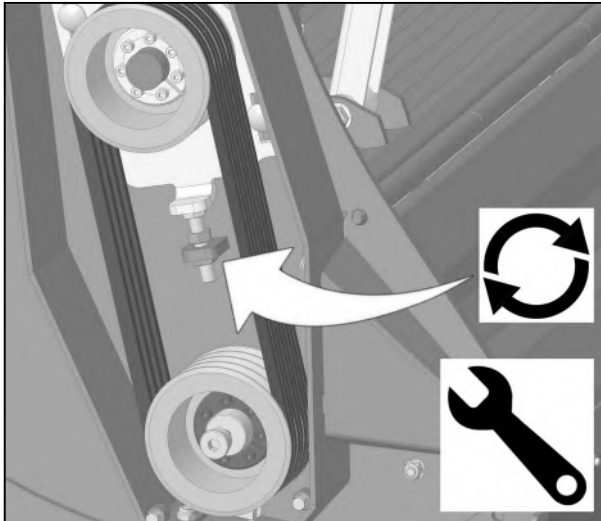
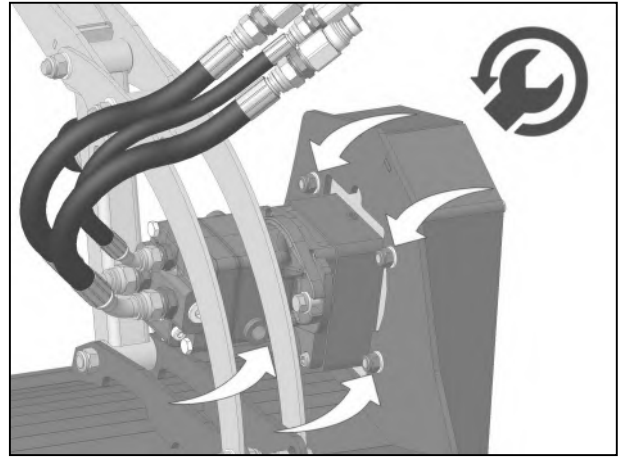

3. Slacken the adjuster locknuts and rotate adjuster bolt to set the correct belt tension - use a tension gauge. Re-tighten adjuster locknuts when belt tension is correct.

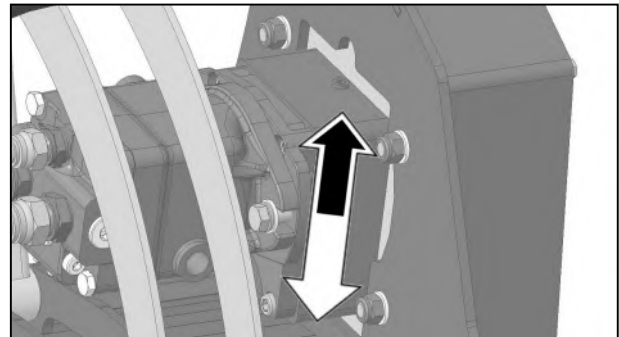

4. Re-tighten nuts on motor mounting block. Re-check belt tension to confirm correct setting.
5. Replace and secure the belt cover before running the machine.

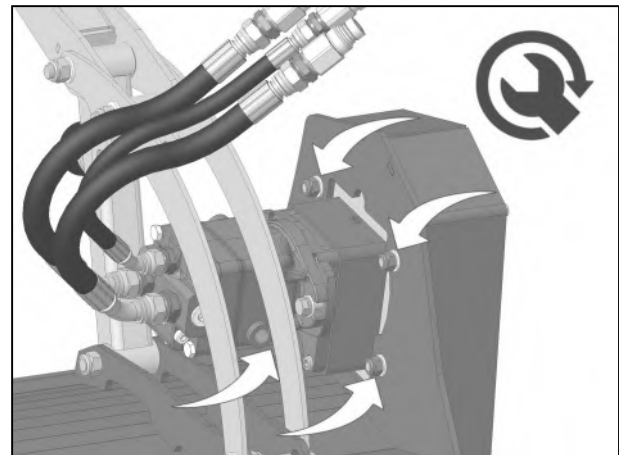
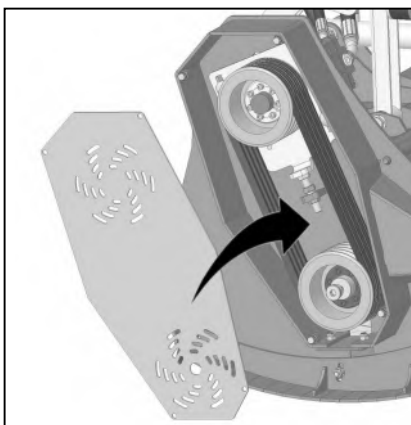

NOTICE

It is advisable to release the belt tension when machine is in placed in storage, re-tension the belts before next use.

Belts Replacement

When replacing drive belts, the procedure is the same as above except the tensioner will need to be loosened enough to allow removal of the old belts and subsequent fitment of the new ones.

Note: When installing new belts, tension should be re-checked after an initial hour or so of operation and re-tensioned if required.

Belt Pulley Alignment

The belt pulleys are secured in position on their shafts by taperlock bushings; when replacing pulleys the lower pulley must be fitted to the rotor shaft first, the pulley and taperlock should be located as far as possible onto the shaft at a minimal distance from casing components and secured with the taperlock.

The upper pulley and taperlock should be subsequently fitted to the drive shaft and positioned in-line with the lower pulley; a suitable straight edge tool placed against the faces of both pulleys should be used to set and confirm alignment.

When the pulleys have been correctly installed the taperlocks must be fully tightened and torqued, refer to taperlock tightening procedure below.

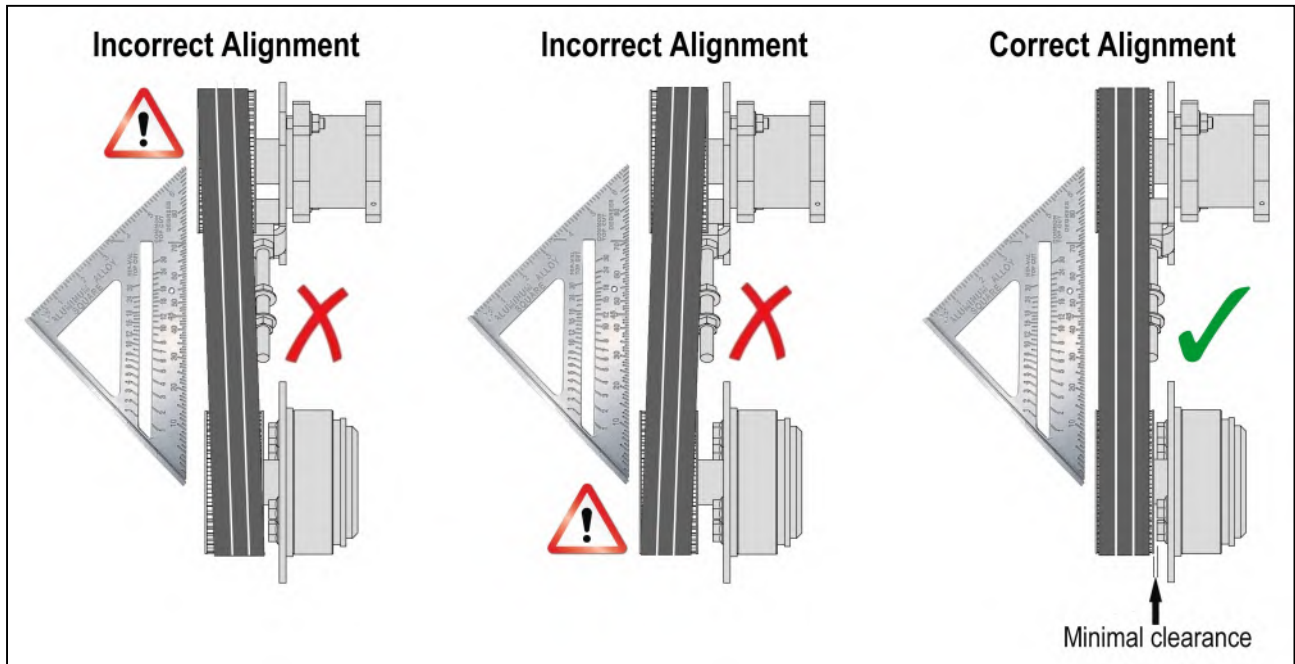

Taperlocks

The pulley taperlocks must be tightened and torqued to **41Nm (30ft-lb)**.

Tighten bolts using a criss-cross tightening sequence to the torque figure stated; repeat the tightening procedure twice on each taperlock.

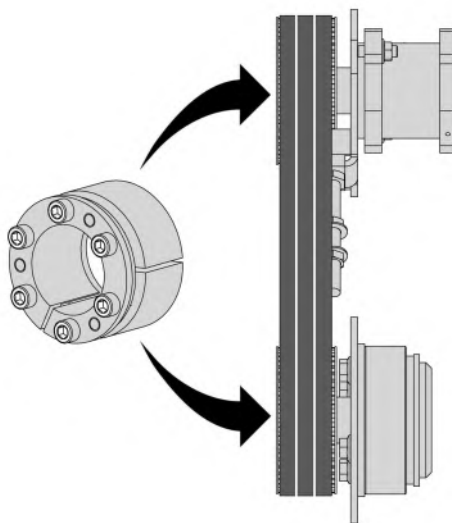

Taperlock Locations

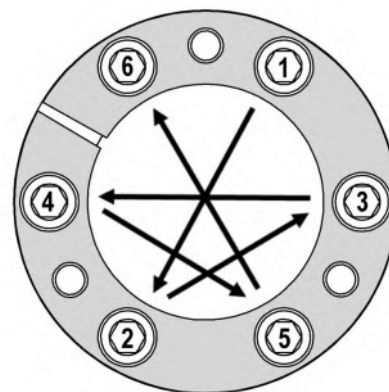

Taperlock Tightening Sequence

Machine Storage

For extended storage periods the machine should be protected from the elements in a clean dry environment. Machine should be cleaned and lubricated prior to storage and parked in a safe stable condition with hoses neatly stowed clear of the ground.

The exposed section of the ram rod should be carefully cleaned and coated in grease to protect the surface from contaminates; this must be subsequently removed prior to next use of the machine.

It is advisable to release the belt tension whenever the machine is in placed in extended storage to preserve the belts, re-tension the belts before next use.

Excessively worn or damaged components should be replaced prior to storage to ensure the machine is fully prepared for the next seasons work.

Ensure the machine is stored in a safe stable condition.

TROUBLESHOOTING CHART

Problem	Possible Cause	Suggested Remedy
Rotor will not turn.	<p>Low oil pressure.</p> <p>Foreign object jamming rotor.</p> <p>Drive belts broken or slipping.</p> <p>Faulty rotor bearing.</p> <p>Internal pump or motor damage.</p>	<p><i>Check oil pressure.</i></p> <p><i>Manually unblock the rotor.</i></p> <p><i>Check and replace or adjust.</i></p> <p><i>Replace bearing(s).</i></p> <p><i>Repair or replace if required.</i></p>
Unusual noise.	<p>Damaged or missing flails.</p> <p>Worn flails.</p> <p>Foreign object in rotor.</p> <p>Loose fixings.</p>	<p><i>Check and replace flails.</i></p> <p><i>Fit new flails & fixings.</i></p> <p><i>Manually unblock the rotor.</i></p> <p><i>Tighten fixings.</i></p>
Excessive vibration.	<p>Mud and/or debris on rotor.</p> <p>Damaged or missing flails.</p> <p>Unbalanced or damaged rotor.</p> <p>Worn rotor bearings.</p>	<p><i>Remove debris, clean rotor.</i></p> <p><i>Check and replace flails.</i></p> <p><i>Balance or replace rotor.</i></p> <p><i>Replace rotor bearings.</i></p>
Poor or uneven cutting.	<p>Flails / teeth excessively worn</p>	<p><i>Replace flails / teeth.</i></p>
Oil leakage.	<p>Seals / hoses worn or damaged.</p>	<p><i>Replace seals / hoses.</i></p>
Belts overheating.	<p>Belts slipping.</p> <p>Rotor tools contacting ground.</p> <p>Forward speed too high for the material.</p>	<p><i>Re-tension belts.</i></p> <p><i>Adjust cutting height.</i></p> <p><i>Reduce forward speed.</i></p>



McConnel Limited, Temeside Works, Ludlow, Shropshire SY8 1JL. England.
Telephone: 01584 873131. Facsimile: 01584 876463. www.mcconnel.com