

Publication 1018
April 2022
Part No. 24215.18



McCONNEL

ROBO-HARROW

ROBOCUT ACCESSORY

Operation Manual

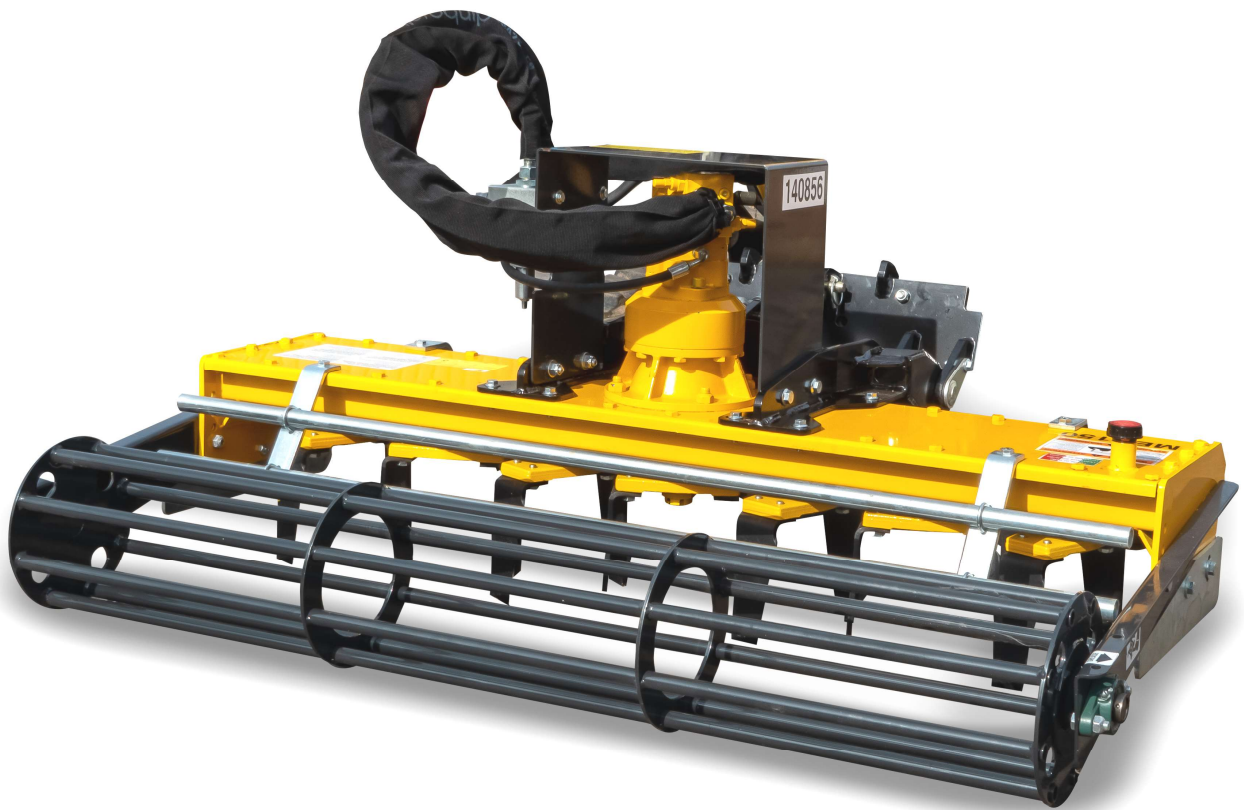

IMPORTANT

VERIFICATION OF WARRANTY REGISTRATION



Dealer Warranty Information & Registration Verification

It is imperative that the selling dealer registers this machine with McConnel Limited before delivery to the end user – failure to do so may affect the validity of the machine warranty.

To register machines; log onto <https://my.mcconnel.com> and select 'Machine Registration' which can be found in the 'Warranty' section of the site. **Confirm to the customer that the machine has been registered by completing the verification form below.**

Registration Verification	Serial No. <input type="text"/>
Dealer Name:	
Dealer Address:	
Customer Name:	
Date of Warranty Registration:/...../.....	Dealer Signature:

Note to Customer / Owner

Please ensure the section above has been completed and signed by the dealer to verify your machine has been registered with McConnel Limited.

IMPORTANT: During the initial 'bedding in' period of a new machine it is the customer's responsibility to regularly inspect all nuts, bolts and hose connections for tightness and re-tighten if required. New hydraulic connections occasionally weep small amounts of oil as the seals and joints settle in – where this occurs it can be cured by re-tightening the connection – *refer to torque settings chart below*. The tasks stated above should be performed on an hourly basis during the first day of work and at least daily thereafter as part of the machine's general maintenance procedure.

CAUTION: DO NOT OVER TORQUE HYDRAULIC FITTINGS AND HOSES

Torque Settings for Hydraulic Fittings

Hydraulic Hose Ends		
BSP	Setting	Metric
1/4"	18 Nm	19 mm
3/8"	31 Nm	22 mm
1/2"	49 Nm	27 mm
5/8"	60 Nm	30 mm
3/4"	80 Nm	32 mm
1"	125 Nm	41 mm
1.1/4"	190 Nm	50 mm
1.1/2"	250 Nm	55 mm
2"	420 Nm	70 mm

Port Adaptors with Bonded Seals		
BSP	Setting	Metric
1/4"	34 Nm	19 mm
3/8"	47 Nm	22 mm
1/2"	102 Nm	27 mm
5/8"	122 Nm	30 mm
3/4"	149 Nm	32 mm
1"	203 Nm	41 mm
1.1/4"	305 Nm	50 mm
1.1/2"	305 Nm	55 mm
2"	400 Nm	70 mm

WARRANTY POLICY

WARRANTY REGISTRATION

All machines must be registered, by the selling dealer with McConnel Ltd, before delivery to the end user. On receipt of the goods it is the buyer's responsibility to check that the Verification of Warranty Registration in the Operator's Manual has been completed by the selling dealer.

1. LIMITED WARRANTIES

1.01. *All mounted machines supplied by McConnel Ltd are warranted to be free from defects in material and workmanship from the date of sale to the original purchaser for a period of 12 months, unless a different period is specified.*

All Self Propelled Machines supplied by McConnel Ltd are warranted to be free from defects in material and workmanship from the date of sale to the original purchaser for a period of 12 months or 1500 hours. Engine warranty will be specific to the Manufacturer of that unit.

1.02. *All spare parts supplied by McConnel Ltd and purchased by the end user are warranted to be free from defects in material and workmanship from the date of sale to the original purchaser for a period of 6 months. All parts warranty claims must be supported by a copy of the failed part invoice to the end user. We cannot consider claims for which sales invoices are not available.*

1.03. *The warranty offered by McConnel Ltd is limited to the making good by repair or replacement for the purchaser any part or parts found, upon examination at its factory, to be defective under normal use and service due to defects in material or workmanship. Returned parts must be complete and unexamined. Pack the component(s) carefully so that any transit damage is avoided. All ports on hydraulic items should be drained of oil and securely plugged to prevent seepage and foreign body ingress. Certain other components, electrical items for example, may require particular care when packing to avoid damage in transit.*

1.04. *This warranty does not extend to any product from which McConnel Ltd's serial number plate has been removed or altered.*

1.05. *The warranty policy is valid for machines registered in line with the terms and conditions detailed and on the basis that the machines do not extend a period of 24 months or greater since their original purchase date, that is the original invoice date from McConnel Limited.*

Machines that are held in stock for more than 24 months cannot be registered for warranty.

1.06. *This warranty does not apply to any part of the goods, which has been subjected to improper or abnormal use, negligence, alteration, modification, fitment of non-genuine parts, accident damage, or damage resulting from contact with overhead power lines, damage caused by foreign objects (e.g. stones, iron, material other than vegetation), failure due to lack of maintenance, use of incorrect oil or lubricants, contamination of the oil, or which has served its normal life. This warranty does not apply to any expendable items such as blades, belts, clutch linings, filter elements, flails, flap kits, skids, soil engaging parts, shields, guards, wear pads, pneumatic tyres or tracks.*

1.07. *Temporary repairs and consequential loss - i.e. oil, downtime and associated parts are specifically excluded from the warranty.*

1.08. *Warranty on hoses is limited to 12 months and does not include hoses which have suffered external damage. Only complete hoses may be returned under warranty, any which have been cut or repaired will be rejected.*

1.09. *Machines must be repaired immediately a problem arises. Continued use of the machine after a problem has occurred can result in further component failures, for which McConnel Ltd cannot be held liable, and may have safety implications.*

1.10. *If in exceptional circumstances a non McConnel Ltd part is used to effect a repair, warranty reimbursement will be at no more than McConnel Ltd's standard dealer cost for the genuine part.*

- 1.11. *Except as provided herein, no employee, agent, dealer or other person is authorised to give any warranties of any nature on behalf of McConnell Ltd.*
- 1.12. *For machine warranty periods in excess of 12 months the following additional exclusions shall apply:*
 - 1.12.1. *Hoses, exposed pipes and hydraulic tank breathers.*
 - 1.12.2. *Filters.*
 - 1.12.3. *Rubber mountings.*
 - 1.12.4. *External electric wiring.*
 - 1.12.5. *Bearings and seals*
 - 1.12.6. *External Cables, Linkages*
 - 1.12.7. *Loose/Corroded Connections, Light Units, LED's*
 - 1.12.8. *Comfort items such as Operator Seat, Ventilation, Audio Equipment*
- 1.13. *All service work, particularly filter changes, must be carried out in accordance with the manufacturer's service schedule. Failure to comply will invalidate the warranty. In the event of a claim, proof of the service work being carried out may be required.*
- 1.14. *Repeat or additional repairs resulting from incorrect diagnosis or poor quality previous repair work are excluded from warranty.*

NB Warranty cover will be invalid if any non-genuine parts have been fitted or used. Use of non-genuine parts may seriously affect the machine's performance and safety. McConnell Ltd cannot be held responsible for any failures or safety implications that arise due to the use of non-genuine parts.

2. REMEDIES AND PROCEDURES

- 2.01. *The warranty is not effective unless the Selling Dealer registers the machine, via the McConnell web site and confirms the registration to the purchaser by completing the confirmation form in the operator's manual.*
- 2.02. *Any fault must be reported to an authorised McConnell Ltd dealer as soon as it occurs. Continued use of a machine, after a fault has occurred, can result in further component failure for which McConnell Ltd cannot be held liable.*
- 2.03. *Repairs should be undertaken within two days of the failure. Claims submitted for repairs undertaken more than 2 weeks after a failure has occurred, or 2 days after the parts were supplied will be rejected, unless the delay has been authorised by McConnell Ltd. Please note that failure by the customer to release the machine for repair will not be accepted as a reason for delay in repair or submitting warranty claims.*
- 2.04. *All claims must be submitted, by an authorised McConnell Ltd Service Dealer, within 30 days of the date of repair.*
- 2.05. *Following examination of the claim and parts, McConnell Ltd will pay, at their discretion, for any valid claim the invoiced cost of any parts supplied by McConnell Ltd and appropriate labour and mileage allowances if applicable.*
- 2.06. *The submission of a claim is not a guarantee of payment.*
- 2.07. *Any decision reached by McConnell Ltd. is final.*

3. LIMITATION OF LIABILITY

- 3.01. *McConnell Ltd disclaims any express (except as set forth herein) and implied warranties with respect to the goods including, but not limited to, merchantability and fitness for a particular purpose.*
- 3.02. *McConnell Ltd makes no warranty as to the design, capability, capacity or suitability for use of the goods.*
- 3.03. *Except as provided herein, McConnell Ltd shall have no liability or responsibility to the purchaser or any other person or entity with respect to any liability, loss, or damage caused or alleged to be caused directly or indirectly by the goods including, but not limited to, any indirect, special, consequential, or incidental damages resulting from the use or operation of the goods or any breach of this warranty. Notwithstanding the above limitations and warranties, the manufacturer's liability hereunder for damages incurred by the purchaser or others shall not exceed the price of the goods.*
- 3.04. *No action arising out of any claimed breach of this warranty or transactions under this warranty may be brought more than one (1) year after the cause of the action has occurred.*

4. MISCELLANEOUS

- 4.01. McConnel Ltd may waive compliance with any of the terms of this limited warranty, but no waiver of any terms shall be deemed to be a waiver of any other term.*
- 4.02. If any provision of this limited warranty shall violate any applicable law and is held to be unenforceable, then the invalidity of such provision shall not invalidate any other provisions herein.*
- 4.03. Applicable law may provide rights and benefits to the purchaser in addition to those provided herein.*

McConnel Limited

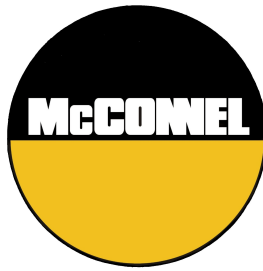

For Safety and Performance...

ALWAYS READ THIS BOOK FIRST

McCONEL LIMITED

**Temeside Works
Ludlow
Shropshire
England**

**Telephone: 01584 873131
www.mcconnel.com**

CONTENTS

General Information	1
Introduction	2
Technical Specifications	2
Machine Identification	2
Safety Information	3
Mounting the Machine	5
Operation	6
Transport	6
Pre-work Checks	7
Harrow Operation	7
Starting Work	7
Working Speed	7
Stopping Work	7
Machine Protection	7
Machine Removal & Storage	7
Maintenance	8
Rotor Grease Points	8
Rotor Transmission Lubrication	8
Checking Oil Level	8
Replacing Transmission Oil	8
Tool Replacement	9
Troubleshooting	9

GENERAL INFORMATION

Read this manual before fitting or operating the machine or accessory. Whenever any doubt exists contact your local dealer or the McConnel Service Department for assistance.

Only use 'Genuine McConnel Parts' on McConnel machinery and equipment.

DEFINITIONS: *The following definitions apply throughout this manual;*

⚠ DANGER

DANGER: Alerts to a hazardous situation which will result in death or serious injury if not observed carefully.

⚠ WARNING

WARNING: Alerts to a hazardous situation which could result in death or serious injury if not observed carefully.

⚠ CAUTION

CAUTION: Alerts to a hazardous situation which could result in damage to the machine and/or equipment if not observed carefully.

NOTICE

NOTICE: Specific or general information considered important or useful to emphasise.

LEFT HAND (LH) & RIGHT HAND (RH): *These terms are applicable to the machine when fitted to the tractor and viewed from the rear; these terms also apply to tractor references.*

SERIAL PLATE

All machines are equipped with a serial number plate containing important information relating to the machine including a unique serial number used for identification purposes.

Note: Images in this manual are provided for instruction and informational purposes only and may not show components in their entirety. In certain instances images may appear different to the actual machine; where this occurs the general procedure will be basically the same. E&OE.

MACHINE & DEALER INFORMATION

Record the serial number of your machine on this page and always quote it when ordering parts. Whenever information concerning the machine is requested remember to also state the make and model of tractor to which the machine is fitted.	
Machine Serial Number:	Installation Date:
Machine Model Details:	
Dealer Name & Branch:	
Dealer Address:	
Dealer Telephone No:	
Dealer Email Address:	

INTRODUCTION

The Robo-Harrow is an all-terrain harrow attachment for use on McConnell Robocut tractor units. The 1.5m harrow, equipped with roller and 14 blades, has a working depth of up to 190mm making it a highly effective and efficient tool for breaking up mud clods and turf, burying fertiliser, and tilling soil.

This attachment must only be used to perform the tasks for which it was designed; use of the machine for any other purposes will risk danger to persons and/or damage to the machinery.

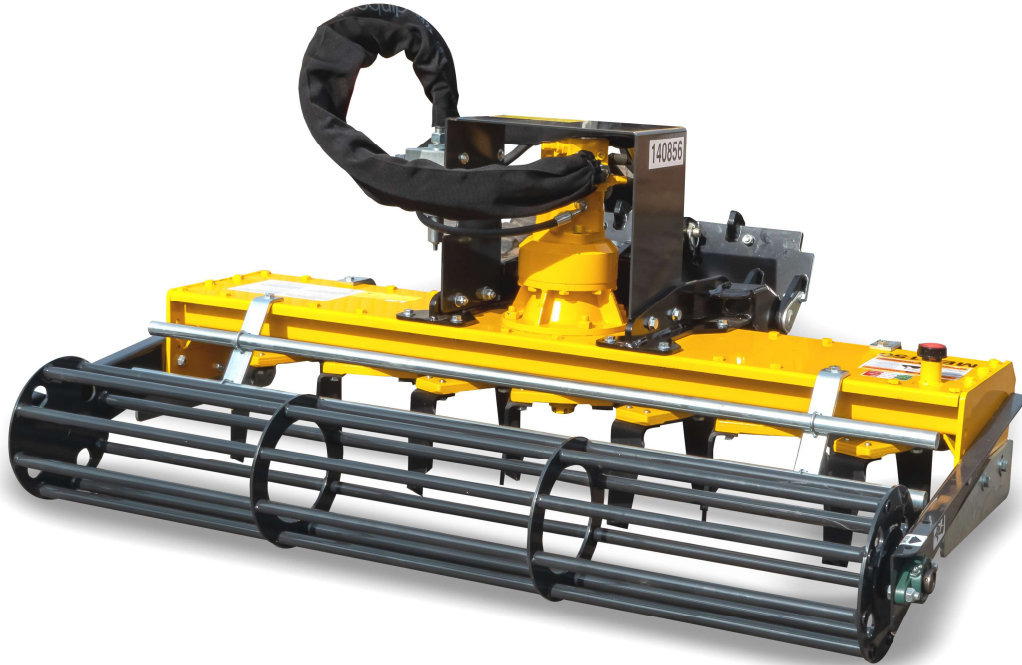

TECHNICAL SPECIFICATIONS

Machine Specification

Width	1550mm
Working Width	1500mm
Power Requirement	30-50HP / 22-38kW
Rotors (No.)	7
Blades (No.)	14
Working Depth	190mm
Weight	546lbs / 248kg

MACHINE IDENTIFICATION

The machine is fitted with an identification plate with the following information:

1. Machine Code
2. Machine Serial No.
3. Machine Weight

When ordering spares or replacement parts from your local dealer, it is important to quote the model code and serial number as stated on the identification plate so the machine can be quickly and correctly identified.

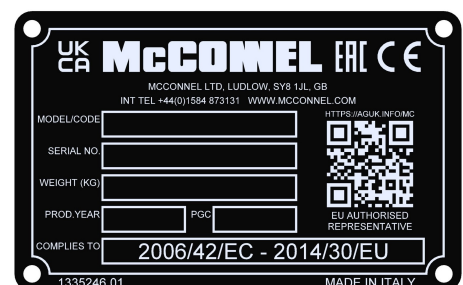

Machine Identification Plate



This manual must be read in conjunction with the operation manual of the specific machine on which this equipment will be mounted.

Users of this equipment should be qualified to operate machinery of this nature and must be fully conversant in all aspects relating to its safe use and operation.

General Safety

- ▲ Read the safety information for all machinery being operated and abide by the rules.
- ▲ Operators must be suitably qualified to operate the machinery.
- ▲ Operators must be familiar with the safe use of the machinery they are operating.
- ▲ Always read and follow the instructions for the use and maintenance of the machine before carrying out any work operations or servicing tasks.
- ▲ Improper use of the machine is both highly dangerous to persons and damaging to the machine components – only use the machine for its designated task.
- ▲ Both operators and the maintenance fitters should be familiar with the machine and fully aware of dangers surrounding improper use or incorrect repairs.
- ▲ Before starting, checks to both the carrying vehicle and the machine must be carried out with regard to functionality, safety, and accident prevention.
- ▲ Immediately replace missing or damaged safety decals.
- ▲ Inspect the work area prior to operation and remove dangerous or hazardous objects.
- ▲ Even when using the machine correctly, stones or other objects may be ejected from the machine, therefore nobody must stand within the danger area. Special attention must be paid when working near roads, vehicles and buildings.
- ▲ The condition of tools and safety guards should be checked before beginning work; they must be replaced if damaged or missing before attempting to operate the machine.
- ▲ During checks or repairs, make sure nobody could start the machine by mistake.
- ▲ Protective clothing and safety equipment appropriate for the job must always be worn.
- ▲ Only operate the machine from a safe position with a clear uninterrupted view of the immediate work area.
- ▲ Before starting the machine, check the surrounding area for the likely presence of persons and/or animals.
- ▲ Never carry passengers on the machine.
- ▲ Do not allow children to operate or play on the machine.
- ▲ Never leave a running machine unattended.
- ▲ Never approach the machine until all moving components have completely stopped.

- ▲ Stop operating the machine immediately and switch it off if persons or animal enter the work zone and do not re-start until they are clear of the danger area.
- ▲ Do not stand ahead of the machine whilst operating.
- ▲ Take extra care when working on rough or uneven terrain.
- ▲ Do not work on slopes in excess of the machines capability.
- ▲ Only operate the machine in daylight conditions or high quality artificial lighting.
- ▲ Before leaving the machine, park it safely on firm level site and remove the carrying vehicle's starting key.

Although the information given here covers a wide range of safety subjects, it is impossible to predict every eventuality that can occur under differing circumstances whilst operating this machine. No advice given here can replace 'good common sense' and 'total awareness' at all times but will go a long way towards the safe use of your McConnel machine.

Personal Safety Gear



Users should wear suitable personal safety gear at all times whilst operating this machine. *Suggested safety gear is as follows;*

- Dust Mask
- Safety Boots
- Eye Protection
- Ear Defenders
- Safety Helmet
- Safety Gloves
- Overalls

Safety Decals



1. **CAUTION!** Read the operator manual.
2. **CAUTION!** Remove starting key before performing maintenance or servicing tasks.
3. **DANGER!** Rotating components - stay at a safe distance when machine is moving.
4. **DANGER!** Flying objects - stay at a safe distance when machine is operating.
5. **DANGER!** Moving blades - stay at a safe distance when machine is running.
6. **DANGER!** Moving components - stay at a safe distance when machine is running.

MOUNTING THE MACHINE

Mounting of the machine should be performed on a firm level site. Keep bystanders at a safe distance from the machinery.

The mounting procedure is as follows;

1. Lower the Robocut mounting frame to a height lower than lugs on mounting frame of Harrow.
2. Carefully manoeuvre the Robocut to a position where the mounting frames are adjacent and centred.
3. Raise the Robocut mounting frame to engage with the lugs on the mounting frame of the Harrow; check bolt holes in the mounting frames are correctly aligned.
4. Connect mounting frames together using the bolts, washers and locknuts provided.

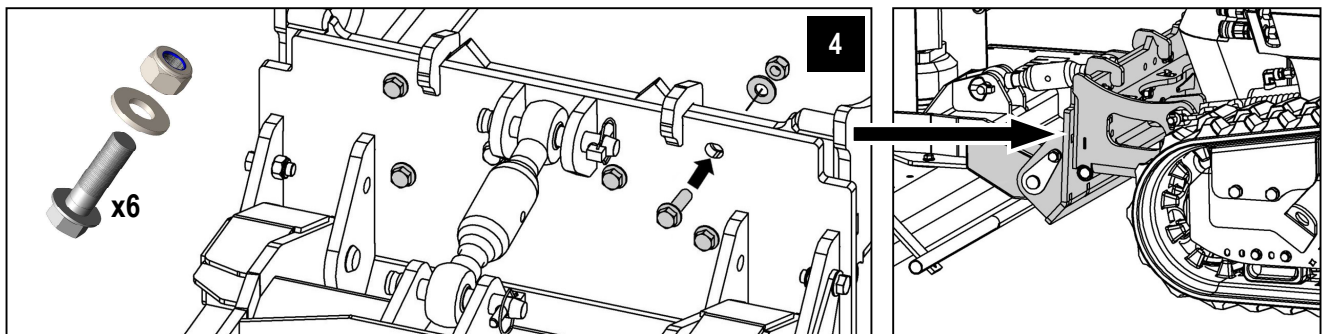
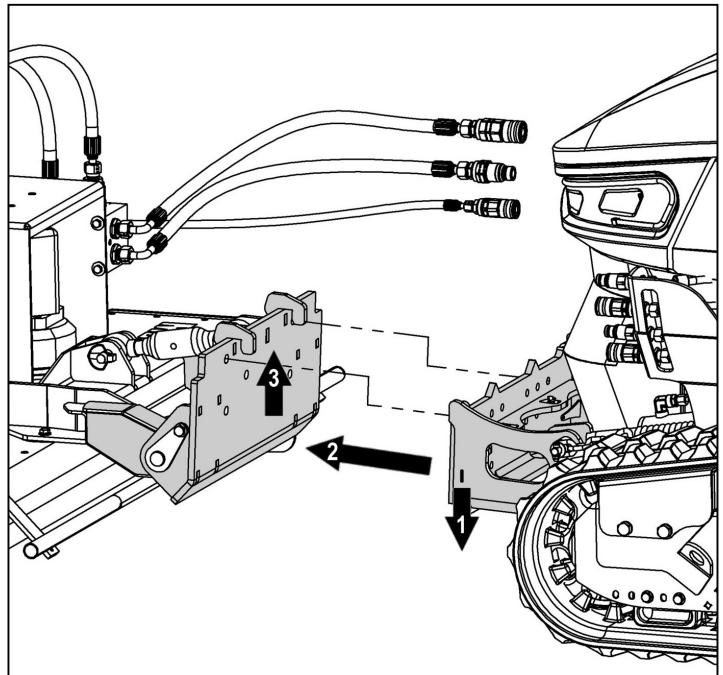

5. Remove the expansion vessel from drain line hose on Harrow.

NOTICE

The expansion vessel should be stored in a safe location and must be reinstalled on the drain line hose whenever the machine is removed.

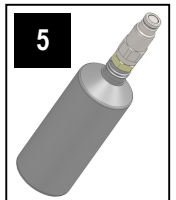

6. Connect the Harrow hoses to the hydraulic connection points on Robocut.

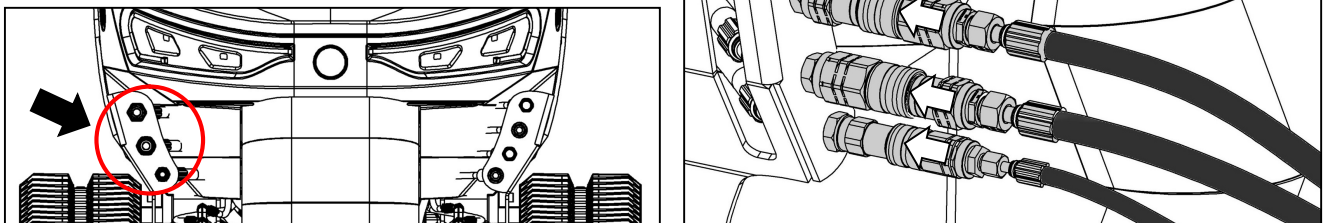

7. Configure attachment type 'ROBO ROTARY HARROW' in settings of Robocut control panel.



Refer to RC56/75 operator manual for information on configuring these settings



OPERATION

Transport

The machine should be raised clear of the ground for transport to and from the work site. Speed should be kept to a minimum during transportation to avoid 'bouncing' that can occur on rough or uneven terrain. **The Harrow must be switched OFF during transportation.**

Controls Identification for Harrow Operation

Refer to Robocut manual for full details of these controls.

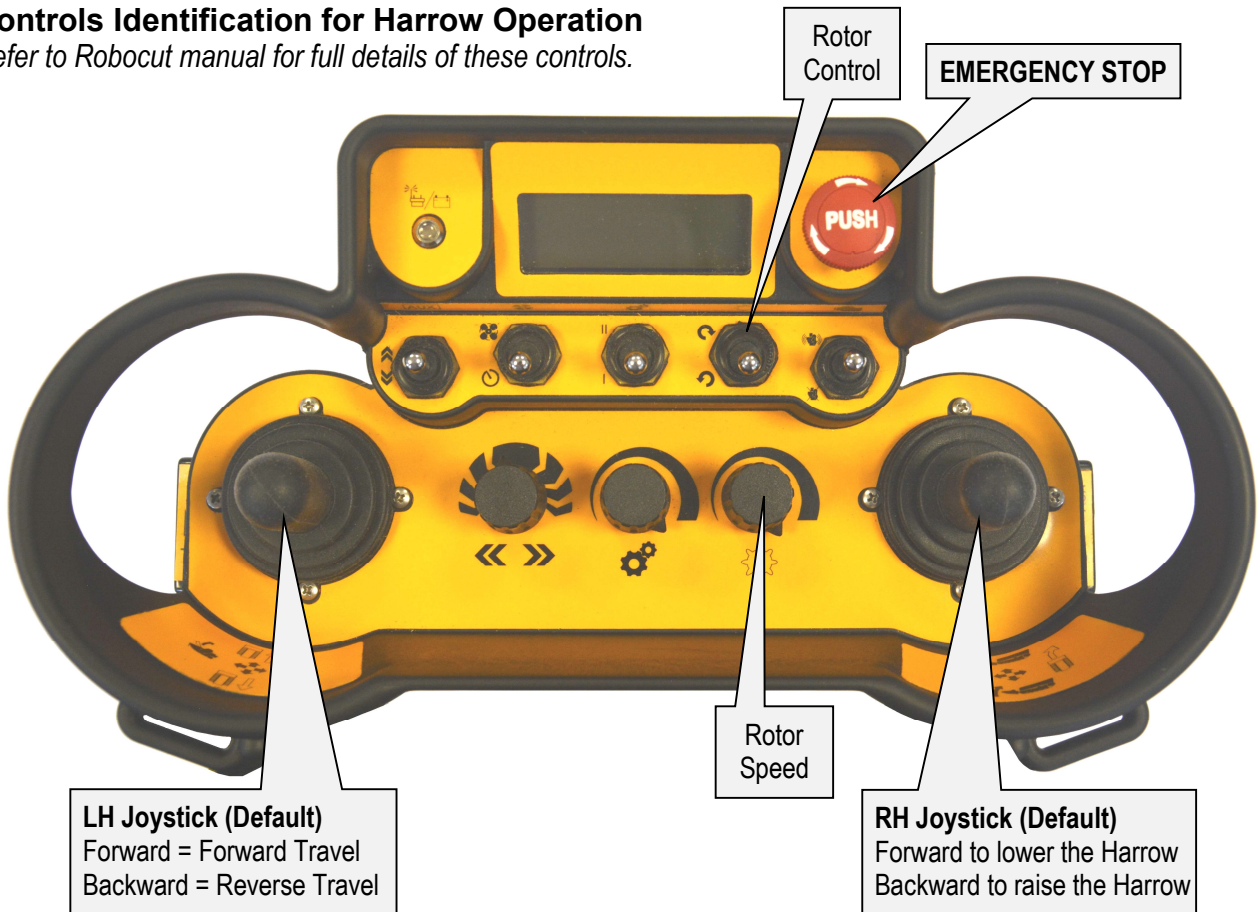

Joystick Controls (Default)

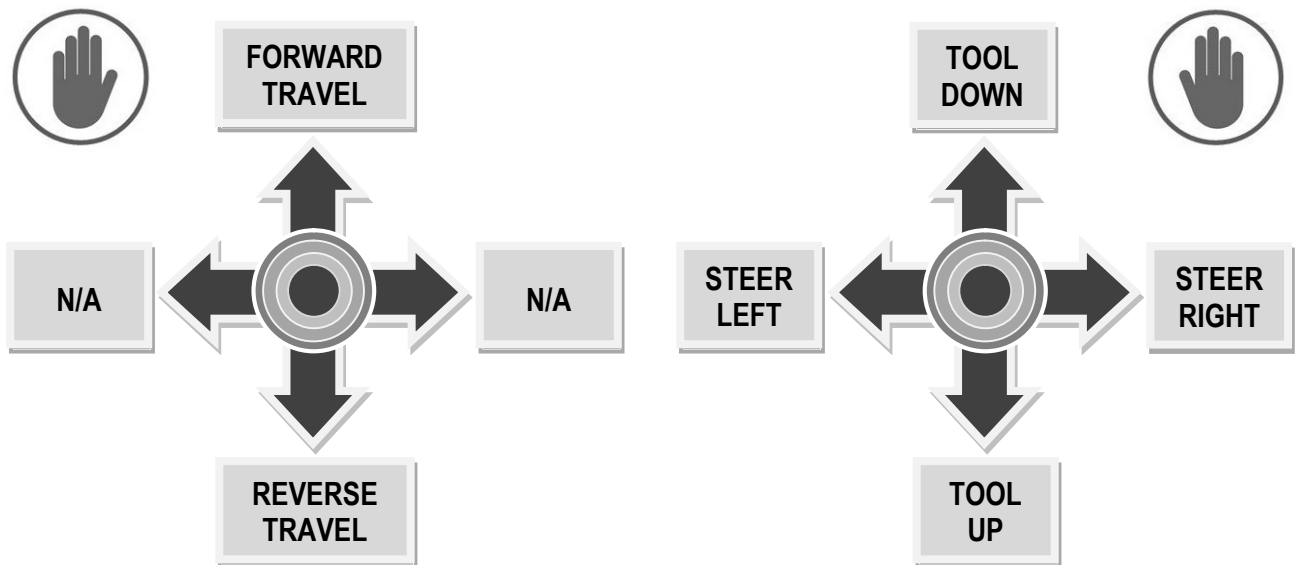

Pre-Work Checks

- Operators must be fully conversant with safe operation and use of the Robocut machine.
- Check machinery is correctly attached and all components and safety features are in good working condition.
- Inspect the work area prior to operation and remove any dangerous objects such as large stones, glass, wire, etc. Immovable hazards should be marked so they can be avoided.
- Ensure persons and/or animals are kept at a safe distance before and during operations.

Harrow Operation

The Harrow operates by being drawn through the ground with its tools rotating; the Robocut must therefore be driven in its reverse direction for work with the Harrow.

NOTE: Robocut controls can be customised by the user to 'swap' the operating directions of the joysticks; refer to the Robocut operator manual for full details of this function.

Starting Work

1. Position the machinery at the start of the work area.
2. Start the rotors with the tools clear of the ground.
3. Ensure the rotors are turning in the correct direction, the harrow tools have a leading edge and must rotate in that direction only.
4. Slowly lower the machine into the ground until tools are at the required working depth.
5. Drive the Robocut at a suitable working speed to draw the machine through the ground.

Working Speed

The maximum forward speed is 3mph (5km/h) but will vary depending on the particular soil type and conditions. The rate of travel should be kept to a speed that allows the machine to work the soil in an efficient manner without labouring.

During work operators must remain vigilant at all times; in addition to monitoring travel ahead of the machinery, they must also monitor the harrow's performance behind and be prepared to make operational adjustments or stop immediately if required.

Stopping Work

Forward travel must be halted and the machine raised out of the ground with the rotors still running. Switch off the rotors as soon as they are clear of the ground. Do not approach the machine until the rotors have stopped turning completely.

Machine Protection

For component protection the Harrow features a relief valve protection system, this diverts oil flow from the rotors and stops them from turning if the tools come into contact with a heavy or immovable object; if this should occur, the operator must halt forward travel immediately and slowly raise the machine out of the ground. When the rotors are clear of the obstruction the system will reset and the rotors will restart.

In certain circumstances excessive forward speed that 'labours' the machine may cause the relief valve to operate, in which case forward speed should be reduced to allow the machine to harrow effectively.

NOTE: The protection system does not relieve the operator of their responsibility to operate carefully, always stay alert and avoid obvious hazards before contact occurs.

Machine Removal & Storage

Unmounting the machine is basically a reversal of the mounting procedure. Ensure the expansion vessel is refitted to the drain line hose when the machine has been removed. Storage of the machine should be in a clean, dry location protected from the elements. Clean the machine and grease all lubrication points prior to storage.

MAINTENANCE

Rotor Grease Points

Grease points are located on the top of each rotor hub; these must be greased prior to initial use and on a daily basis thereafter. Lubricate grease points fully before and after storage.

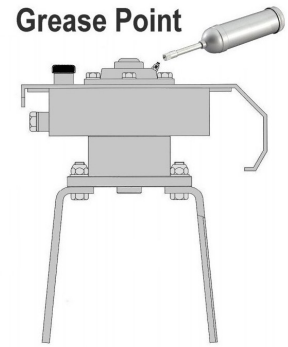

Grease Type: Multifunction Lithium Based Grease NLGI 2.

Rotor Transmission Lubrication (Oil Reservoir)

The gear mechanism for the rotors is located within an oil reservoir that spans the width of the machine. The oil level in the reservoir should be **checked prior to initial use of the new machine and checked again after the first 10 hours of work**; top up if required.

Oil Type: SAE 140 EP Gear Oil

Oil Capacity: Approximately 6.5 Litre (1.5m Model)

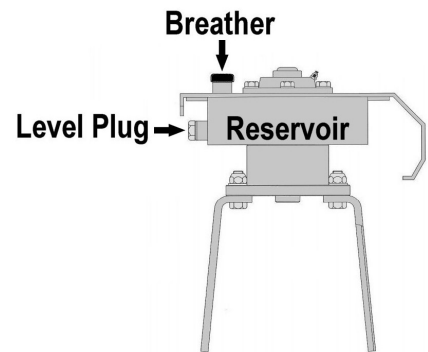
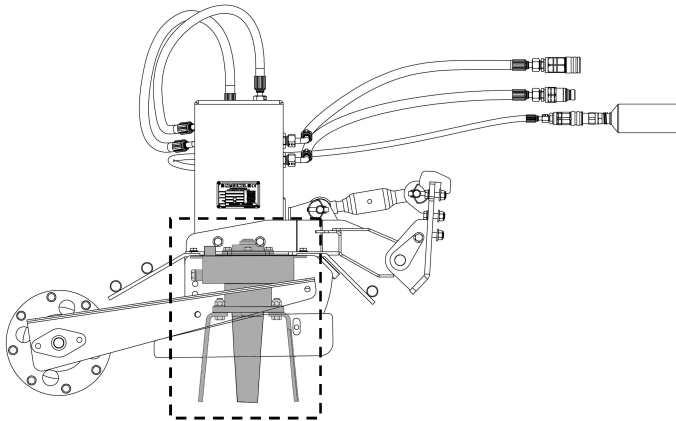

The oil level in the reservoir should be checked every **30 hours** during normal use and the oil replaced every **500 hours** or annually, *whichever occurs first*.

Checking Oil Level

Oil level should be checked with the machine parked on level ground; the machine must be level from side to side and back to front.

Checking the oil is by removal of the level plug - the oil level in the reservoir should be in line with the bottom of the level plug orifice; if oil level is too low, add additional oil until it begins to seep out of the level plug orifice before replacing the plug.

Rotor Transmission Oil Replacement (500 hours / Annually)

Draining the oil from the reservoir is performed via the level plug, this can be done either by tipping the machine backwards to an angle where the oil will fully drain out, or alternatively by using an oil syphon. In both cases, the oil must be collected in a suitable receptacle and disposed of in an environmentally friendly manner.

Refill the reservoir with the machine perfectly level to a point where the oil begins to seep out of the level plug orifice before replacing the plug.

Run the machine for a short period and re-check the level.

Tools Replacement

The tools (tines) must be replaced when excessively worn or damaged; each tool is attached to the rotor with 2 sets of bolts, washers and nuts.

The tines have a leading edge and are either left or right-handed depending on the rotational direction of the rotor they are mounted on.

When replacing tines ensure that the correct ones are installed for the working direction of that rotor.

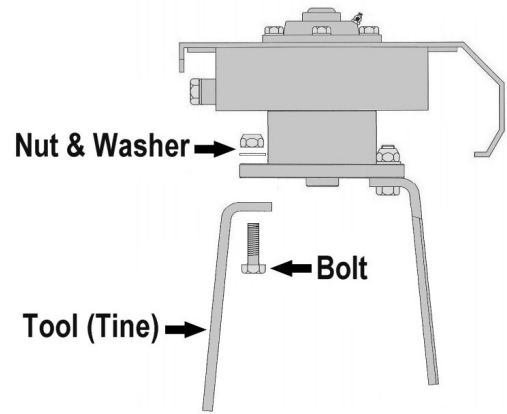

TROUBLESHOOTING

Problem	Possible Cause	Remedy
Insufficient working depth	Blunt or damaged tools	Replace tools Reduce forward speed
Tools not penetrating ground Machine bounce / vibration	Broken or damaged tools Loose tools Foreign object in tools Soil too hard or too dry	Replace tools Tighten tool fixings Remove any foreign objects
Rotor jamming	Soil too wet	Reduce working depth Increase rotor speed
Excessive tilling of the soil	Forward speed too slow Rotor speed too fast	Increase forward speed Reduce rotor speed
Poor tilling of the soil	Forward speed too fast Rotor speed too slow	Reduce forward speed Increase rotor speed



McConnel Limited, Temeside Works, Ludlow, Shropshire SY8 1JL. England.
Telephone: 01584 873131. Facsimile: 01584 876463. www.mcconnel.com