

Publication 934  
April 2019  
Part No. 24214.34  
Revision: 12.07.23



# McCANNEL

## ROBO-FLAILHEAD

1300, 1600 & 1900 Models

56HP Builds: 4056100 / 4056101 / 4056102 / 4056103 / 4056104 / 4056105

75HP Builds: 4075100 / 4075101 / 4075102 / 4075103 / 4075104 / 4075105

Operator Manual



# IMPORTANT

## VERIFICATION OF WARRANTY REGISTRATION



### Dealer Warranty Information & Registration Verification

It is imperative that the selling dealer registers this machine with McConnel Limited before delivery to the end user – failure to do so may affect the validity of the machine warranty.

To register machines; log onto <https://my.mcconnel.com> and select 'Machine Registration' which can be found in the 'Warranty' section of the site. **Confirm to the customer that the machine has been registered by completing the verification form below.**

|  |                                 |
|--|---------------------------------|
| <b>Registration Verification</b>   | Serial No. <input type="text"/> |
| Dealer Name: .....   |                                 |
| Dealer Address: .....  |                                 |
| Customer Name: .....   |                                 |
| Date of Warranty Registration: ...../...../..... Dealer Signature: ..... |                                 |

### Note to Customer / Owner

Please ensure the section above has been completed and signed by the dealer to verify your machine has been registered with McConnel Limited.

**IMPORTANT:** During the initial 'bedding in' period of a new machine it is the customer's responsibility to regularly inspect all nuts, bolts and hose connections for tightness and re-tighten if required. New hydraulic connections occasionally weep small amounts of oil as the seals and joints settle in – where this occurs it can be cured by re-tightening the connection – *refer to torque settings chart below*. The tasks stated above should be performed on an hourly basis during the first day of work and at least daily thereafter as part of the machine's general maintenance procedure.

CAUTION: DO NOT OVER TORQUE HYDRAULIC FITTINGS AND HOSES

### Torque Settings for Hydraulic Fittings

| Hydraulic Hose Ends |         |        |
|---------------------|---------|--------|
| BSP                 | Setting | Metric |
| 1/4"                | 18 Nm   | 19 mm  |
| 3/8"                | 31 Nm   | 22 mm  |
| 1/2"                | 49 Nm   | 27 mm  |
| 5/8"                | 60 Nm   | 30 mm  |
| 3/4"                | 80 Nm   | 32 mm  |
| 1"                  | 125 Nm  | 41 mm  |
| 1.1/4"              | 190 Nm  | 50 mm  |
| 1.1/2"              | 250 Nm  | 55 mm  |
| 2"                  | 420 Nm  | 70 mm  |

| Port Adaptors with Bonded Seals |         |        |
|---------------------------------|---------|--------|
| BSP                             | Setting | Metric |
| 1/4"                            | 34 Nm   | 19 mm  |
| 3/8"                            | 47 Nm   | 22 mm  |
| 1/2"                            | 102 Nm  | 27 mm  |
| 5/8"                            | 122 Nm  | 30 mm  |
| 3/4"                            | 149 Nm  | 32 mm  |
| 1"                              | 203 Nm  | 41 mm  |
| 1.1/4"                          | 305 Nm  | 50 mm  |
| 1.1/2"                          | 305 Nm  | 55 mm  |
| 2"                              | 400 Nm  | 70 mm  |



# WARRANTY POLICY

## WARRANTY REGISTRATION

All machines must be registered, by the selling dealer with McConnel Ltd, before delivery to the end user. On receipt of the goods it is the buyer's responsibility to check that the Verification of Warranty Registration in the Operator's Manual has been completed by the selling dealer.

### 1. LIMITED WARRANTIES

1.01. *All mounted machines supplied by McConnel Ltd are warranted to be free from defects in material and workmanship from the date of sale to the original purchaser for a period of 12 months, unless a different period is specified.*

*All Self Propelled Machines supplied by McConnel Ltd are warranted to be free from defects in material and workmanship from the date of sale to the original purchaser for a period of 12 months or 1500 hours. Engine warranty will be specific to the Manufacturer of that unit.*

1.02. *All spare parts supplied by McConnel Ltd and purchased by the end user are warranted to be free from defects in material and workmanship from the date of sale to the original purchaser for a period of 6 months. All parts warranty claims must be supported by a copy of the failed part invoice to the end user. We cannot consider claims for which sales invoices are not available.*

1.03. *The warranty offered by McConnel Ltd is limited to the making good by repair or replacement for the purchaser any part or parts found, upon examination at its factory, to be defective under normal use and service due to defects in material or workmanship. Returned parts must be complete and unexamined. Pack the component(s) carefully so that any transit damage is avoided. All ports on hydraulic items should be drained of oil and securely plugged to prevent seepage and foreign body ingress. Certain other components, electrical items for example, may require particular care when packing to avoid damage in transit.*

1.04. *This warranty does not extend to any product from which McConnel Ltd's serial number plate has been removed or altered.*

1.05. *The warranty policy is valid for machines registered in line with the terms and conditions detailed and on the basis that the machines do not extend a period of 24 months or greater since their original purchase date, that is the original invoice date from McConnel Limited.*

*Machines that are held in stock for more than 24 months cannot be registered for warranty.*

1.06. *This warranty does not apply to any part of the goods, which has been subjected to improper or abnormal use, negligence, alteration, modification, fitment of non-genuine parts, accident damage, or damage resulting from contact with overhead power lines, damage caused by foreign objects (e.g. stones, iron, material other than vegetation), failure due to lack of maintenance, use of incorrect oil or lubricants, contamination of the oil, or which has served its normal life. This warranty does not apply to any expendable items such as blades, belts, clutch linings, filter elements, flails, flap kits, skids, soil engaging parts, shields, guards, wear pads, pneumatic tyres or tracks.*

1.07. *Temporary repairs and consequential loss - i.e. oil, downtime and associated parts are specifically excluded from the warranty.*

1.08. *Warranty on hoses is limited to 12 months and does not include hoses which have suffered external damage. Only complete hoses may be returned under warranty, any which have been cut or repaired will be rejected.*

1.09. *Machines must be repaired immediately a problem arises. Continued use of the machine after a problem has occurred can result in further component failures, for which McConnel Ltd cannot be held liable, and may have safety implications.*

1.10. *If in exceptional circumstances a non McConnel Ltd part is used to effect a repair, warranty reimbursement will be at no more than McConnel Ltd's standard dealer cost for the genuine part.*

- 1.11. *Except as provided herein, no employee, agent, dealer or other person is authorised to give any warranties of any nature on behalf of McConnell Ltd.*
- 1.12. *For machine warranty periods in excess of 12 months the following additional exclusions shall apply:*
  - 1.12.1. *Hoses, exposed pipes and hydraulic tank breathers.*
  - 1.12.2. *Filters.*
  - 1.12.3. *Rubber mountings.*
  - 1.12.4. *External electric wiring.*
  - 1.12.5. *Bearings and seals*
  - 1.12.6. *External Cables, Linkages*
  - 1.12.7. *Loose/Corroded Connections, Light Units, LED's*
  - 1.12.8. *Comfort items such as Operator Seat, Ventilation, Audio Equipment*
- 1.13. *All service work, particularly filter changes, must be carried out in accordance with the manufacturer's service schedule. Failure to comply will invalidate the warranty. In the event of a claim, proof of the service work being carried out may be required.*
- 1.14. *Repeat or additional repairs resulting from incorrect diagnosis or poor quality previous repair work are excluded from warranty.*

***NB Warranty cover will be invalid if any non-genuine parts have been fitted or used. Use of non-genuine parts may seriously affect the machine's performance and safety. McConnell Ltd cannot be held responsible for any failures or safety implications that arise due to the use of non-genuine parts.***

## **2. REMEDIES AND PROCEDURES**

- 2.01. *The warranty is not effective unless the Selling Dealer registers the machine, via the McConnell web site and confirms the registration to the purchaser by completing the confirmation form in the operator's manual.*
- 2.02. *Any fault must be reported to an authorised McConnell Ltd dealer as soon as it occurs. Continued use of a machine, after a fault has occurred, can result in further component failure for which McConnell Ltd cannot be held liable.*
- 2.03. *Repairs should be undertaken within two days of the failure. Claims submitted for repairs undertaken more than 2 weeks after a failure has occurred, or 2 days after the parts were supplied will be rejected, unless the delay has been authorised by McConnell Ltd. Please note that failure by the customer to release the machine for repair will not be accepted as a reason for delay in repair or submitting warranty claims.*
- 2.04. *All claims must be submitted, by an authorised McConnell Ltd Service Dealer, within 30 days of the date of repair.*
- 2.05. *Following examination of the claim and parts, McConnell Ltd will pay, at their discretion, for any valid claim the invoiced cost of any parts supplied by McConnell Ltd and appropriate labour and mileage allowances if applicable.*
- 2.06. *The submission of a claim is not a guarantee of payment.*
- 2.07. *Any decision reached by McConnell Ltd. is final.*

## **3. LIMITATION OF LIABILITY**

- 3.01. *McConnell Ltd disclaims any express (except as set forth herein) and implied warranties with respect to the goods including, but not limited to, merchantability and fitness for a particular purpose.*
- 3.02. *McConnell Ltd makes no warranty as to the design, capability, capacity or suitability for use of the goods.*
- 3.03. *Except as provided herein, McConnell Ltd shall have no liability or responsibility to the purchaser or any other person or entity with respect to any liability, loss, or damage caused or alleged to be caused directly or indirectly by the goods including, but not limited to, any indirect, special, consequential, or incidental damages resulting from the use or operation of the goods or any breach of this warranty. Notwithstanding the above limitations and warranties, the manufacturer's liability hereunder for damages incurred by the purchaser or others shall not exceed the price of the goods.*
- 3.04. *No action arising out of any claimed breach of this warranty or transactions under this warranty may be brought more than one (1) year after the cause of the action has occurred.*

#### **4. MISCELLANEOUS**

- 4.01. McConnel Ltd may waive compliance with any of the terms of this limited warranty, but no waiver of any terms shall be deemed to be a waiver of any other term.*
- 4.02. If any provision of this limited warranty shall violate any applicable law and is held to be unenforceable, then the invalidity of such provision shall not invalidate any other provisions herein.*
- 4.03. Applicable law may provide rights and benefits to the purchaser in addition to those provided herein.*

---

*McConnel Limited*





*For Safety and Performance...*

**ALWAYS READ THE BOOK FIRST**



**McCONEl LIMITED**

**Temeside Works  
Ludlow  
Shropshire  
England**

**Telephone: +44 (0)1584 873131  
www.mcconel.com**

**This manual must be read and used in conjunction with:  
ROBOCUT Operation Manual**

**Robocut operation manuals are available on our website via the links below;**



In line with our policy of constant improvement this publication may be periodically updated. To ensure you have access to the latest version of this manual please visit the manuals library on our website where an up-to-date version can be referenced online or downloaded.

To access manuals use the QR code opposite or the web address below;

<https://my.mcconel.com/service/pdf-manuals/pdf-operator-manuals/remote-control-technology-manuals/>





# CONTENTS

---

|  |    |
|--|----|
| General Information .....                  | 1  |
| Machine Description .....                  | 2  |
| Machine Identification .....               | 2  |
| Component Identification .....             | 3  |
| Technical Specifications .....             | 4  |
| Dimensions .....                           | 5  |
| Flailhead Use - Important Information..... | 6  |
| Safety Information.....                    | 6  |
| Safety Decals.....                         | 10 |
| Attaching The Flailhead .....              | 11 |
| Hydraulic Connections .....                | 13 |
| Flailhead Controls.....                    | 14 |
| Front Hood.....                            | 16 |
| Rear Roller & Side Skids .....             | 17 |
| Float & Angle .....                        | 18 |
| Rotor Operation .....                      | 18 |
| Rotors & Flails .....                      | 19 |
| Drive Belt .....                           | 20 |
| General Maintenance .....                  | 22 |



## GENERAL INFORMATION

---

Read this manual before fitting or operating the machine or accessory. Whenever any doubt exists contact your local dealer or the McConnell Service Department for assistance.

**Only use 'Genuine McConnell Parts' on McConnell machinery and equipment.**

DEFINITIONS: *The following definitions apply throughout this manual;*

### **⚠ DANGER**

**DANGER:** Alerts to a hazardous situation which will result in death or serious injury if not observed carefully.

### **⚠ WARNING**

**WARNING:** Alerts to a hazardous situation which could result in death or serious injury if not observed carefully.

### **⚠ CAUTION**

**CAUTION:** Alerts to a hazardous situation which could result in damage to the machine and/or equipment if not observed carefully.

### **NOTICE**

**NOTICE:** Specific or general information considered important or useful to emphasise.

**LEFT HAND (LH) & RIGHT HAND (RH):** *These terms are applicable to the machine when fitted to the tractor and viewed from the rear; these terms also apply to tractor references.*

### SERIAL PLATE

*All machines are equipped with a serial number plate containing important information relating to the machine including a unique serial number used for identification purposes.*

*Note: Images in this manual are provided for instruction and informational purposes only and may not show components in their entirety. In certain instances images may appear different to the actual machine; where this occurs the general procedure will be basically the same. E&OE.*

## NOISE LEVEL

---

**L<sub>pA</sub>**  
**99**

**L<sub>pA</sub>** = the value indicates the maximum sound level perceived by the operator at a distance of 1m from the machine.

**L<sub>WA</sub>**  
**105**

**L<sub>WA</sub>** = the value indicates the sound level outside the machine and refers to the noise perceived by those who are in the vicinity of the work area.

## MACHINE DESCRIPTION

These machines are high performance grass flailheads specifically designed for use with Robocut remote controlled tracked carrying vehicles.

Machines are equipped with 3000 rpm energy-efficient spiral rotors that can be fitted with hammer flails or back-to-back grass Y-flails. Machines are available in working widths of 1.3m, 1.6m and 1.9m and feature a hydraulic front hood and adjustable float.



*Machines must only be used to perform tasks for which they were specifically designed; use of the machines for any other reason could be dangerous to persons and damaging to the machine.*

## MACHINE IDENTIFICATION

Machines are fitted with an identification plate in the location indicated here, this contains information that can be used to identify your exact machine and model. Always quote the details from this identification plate when ordering replacement parts or seeking service information and/or advice.

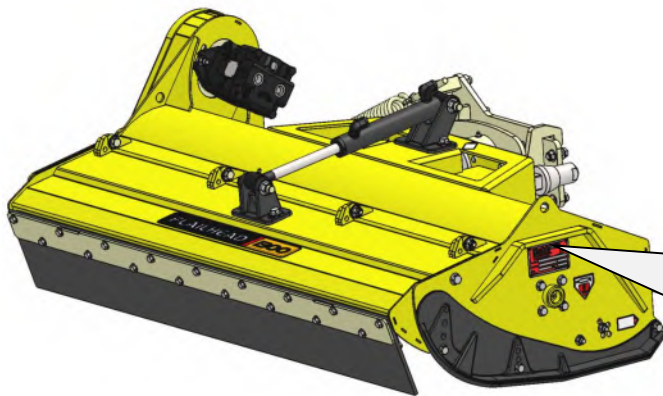

## MACHINE & DEALER INFORMATION

|   |                            |
|---|----------------------------|
| <b>Record serial numbers and dealer contact information here. Always quote serial numbers when ordering replacement parts or seeking service information and/or advice.</b> |                            |
| Machine Serial Number:  | Machine Installation Date: |
| Engine Serial Number:   |                            |
| Machine Model Details:  |                            |
| Dealer Name & Branch:   |                            |
| Dealer Address:   |                            |
| Dealer Telephone No:  |                            |
| Dealer Email Address:   |                            |

## COMPONENT IDENTIFICATION

The illustrations below identify the main components of the machines.

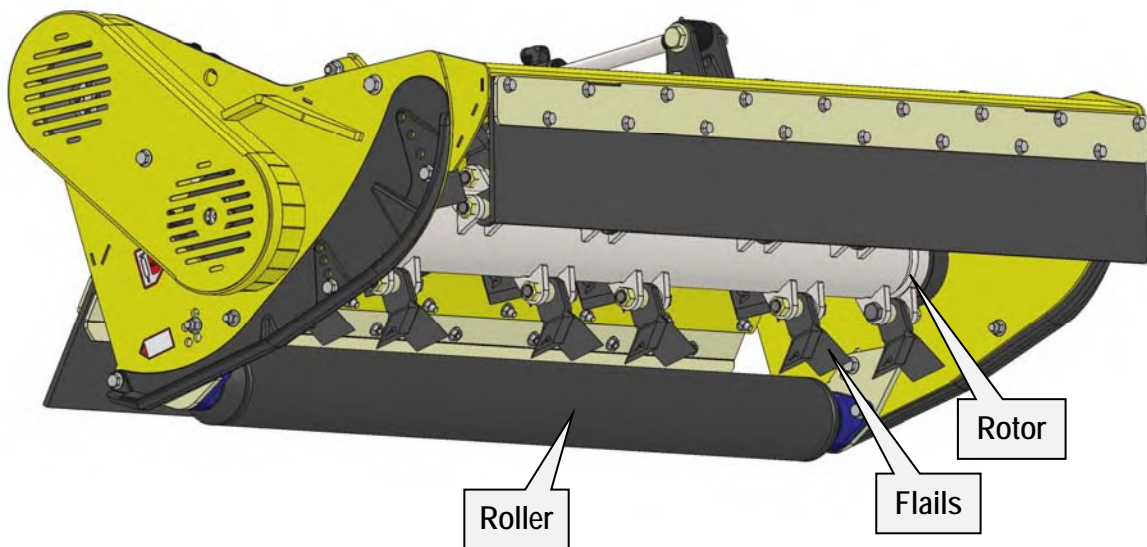
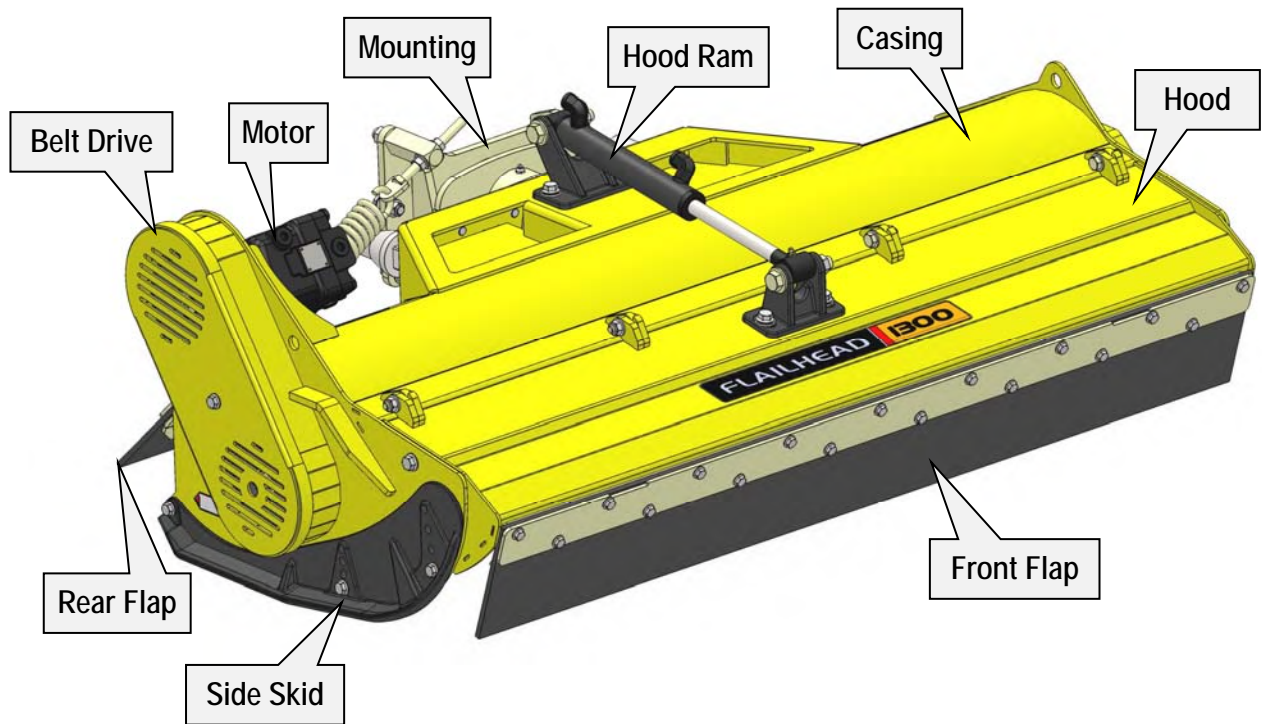

*1300 model with Y-Flails illustrated.*

## TECHNICAL SPECIFICATIONS

---

### Machine Specifications

- Available in 1.3m, 1.6m or 1.9m working widths
- Belt driven rotor
- Hydraulic front hood
- Choice of grass cutting flails or hammer flails
- Full width height adjustable rear roller
- Height adjustable skids
- 30mm cutting capacity
- 20-85mm cutting height
- +/- 14 degree head angling and floatation
- 3000 rpm rotor speed
- 56HP & 75HP builds

# DIMENSIONS

## Flailhead Dimensions

### 1.3m Model

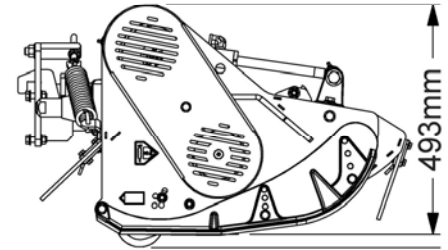
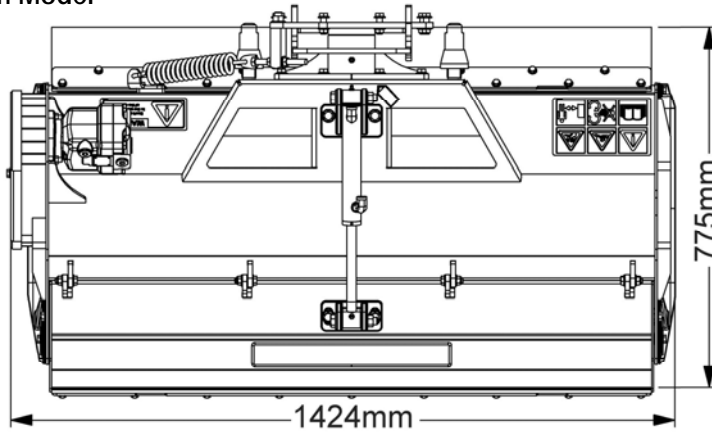

1.3m, 1.6m & 1.9m Models

### 1.6m Model

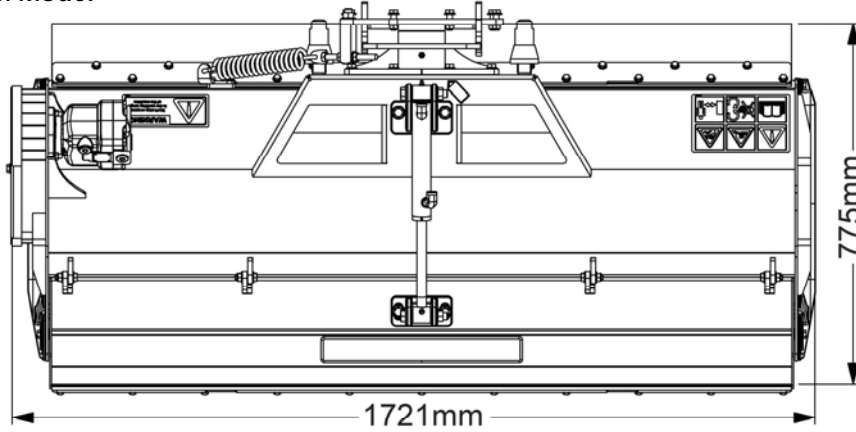

### 1.9m Model

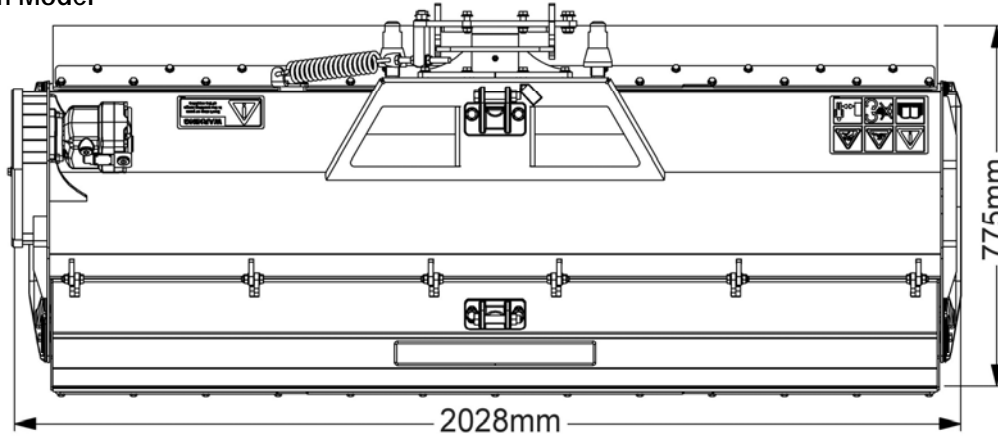



## FLAILHEAD USE - IMPORTANT INFORMATION

### 'As Supplied'

The flailhead is fitted with a hydraulic ram to allow movement of the hinged hood, **by default on every start-up movement of this ram is electronically deactivated** to stop operators inadvertently opening the hood when cutting alongside the highway; this reduces the risk to passing traffic from being hit by objects ejected at speed from the working flail head. It should be noted that with the hinged hood opened objects could be thrown a considerable distance. Being struck by a thrown object could result in injury or death.

If the machine is being used away from the highway, where other vehicles and bystanders are not normally in the vicinity, the hood ram function may be activated provided the general safety information and following specific conditions are met;

- A detailed work area and bystander risk assessment is undertaken before work begins.
- The operator has been trained in the safe use of the Robocut.
- All pre-work checks stated in this manual have been fully performed.



On machines mounted with a grass flailhead, the hood warning screen will always be displayed on start-up; it is the operator's responsibility to ensure all safety conditions are met before selecting the option to activate the hood. Operators of this machine are responsible for the safety of all persons and property in the vicinity of the working machine; if doubt exists work should only be performed with the hood de-activated.

**PLEASE CONFIRM THAT  
YOU HAVE FULLY READ PAGE  
6 OF THE OPERATORS MANUAL.**

**PLEASE CONFIRM IT IS SAFE TO  
ACTIVATE THE FRONT HOOD? IF IT IS  
NOT SAFE, DO NOT ACTIVATE.**

**ACTIVATE**

**DEACTIVATE**













This machine and any attached equipment has the potential to be extremely dangerous - in the wrong hands it can kill or maim; It is therefore imperative that both owner and operator of the machine reads the following section to ensure they are fully aware of the dangers that do, or may exist, and fully understand their responsibilities surrounding use and operation of this machinery.

The operator of this machine is responsible not only for their own safety but equally for the safety of all others who may come into the close proximity of the machine, as the owner you are responsible for both.

When the machine is not in use it should be parked on a firm level site with any mounted equipment at rest on the ground with the isolator key removed.

In the event of any fault being detected with the machine's operation it must be stopped immediately and not used again until the fault has been corrected by a qualified technician.

-  *Before starting the machine the operator must read and understand all aspects of use and maintenance of the machine as stated in this manual.*
-  *The machine must only be used by a responsible adult who is familiar with all aspects relating to safe operation. Certificated training may be required on certain sites.*
-  *The machine must not be operated by children or non-authorized persons.*
-  *Operators must know the meaning of all operation and safety decals on the machine, the mounted attachments, and the remote control unit.*
-  *Operators must know the correct procedure for switching the machine off normally and know the locations of all Emergency Stop buttons.*
-  *Do not attempt to use the machine if any of the Emergency Stop buttons are damaged or malfunctioning.*
-  *Never use the machine with safety guarding removed or defective.*
-  *Operators should practice operation on flat open ground to familiarise themselves with driving and manoeuvring the machine before attempting to use it on sloping ground.*
-  *Operators should practice manoeuvring the machine around obstacles, without the mounted equipment running, before using the machine for work purposes.*
-  *Never operate the machine if your vision is blocked or obscured by obstacles such as vehicles, buildings, hedges, fences etc.; move to a safe position where you have a clear, un-interrupted view of the entire machine.*

- ⚠ Never operate the machine when standing directly in the line of travel.*
- ⚠ Do not use the machine on sand piles, gravel, or other similar loose materials.*
- ⚠ Only operate the machine in good light conditions.*
- ⚠ Never start or run the machine in an enclosed area or building.*
- ⚠ Keep the machine clean to avoid build ups of dry materials that could ignite on hot components.*
- ⚠ Never stand directly below a machine that is working or parked on a slope.*
- ⚠ Always operate the joystick control slowly; rapid or jerky movements could cause the machine to 'rear up' causing loss of control.*
- ⚠ When operating the machine with the flail head running the operator must remain in a safe position at least 5 metres away from the machine; always switch the flail head off before approaching the machinery.*
- ⚠ When using the machine the operator should place themselves in a position that provides optimum visibility over the entire work area.*
- ⚠ Never leave a running machine unattended; always switch the engine off and remove the isolator key.*
- ⚠ Always stop and switch the machine off if persons or animals enter the work area; do not restart the machine until they are at a safe distance.*
- ⚠ Never use the machine to perform tasks it was not designed for.*
- ⚠ Never ride or allow others to ride on the machine.*
- ⚠ Always inspect the work area prior to operation and remove stones, glass, metal, wire or any other foreign objects that are hazardous. Immovable hazards should be suitably 'marked' so they can be easily avoided.*
- ⚠ Take extra care when operating the machine on slopes or uneven ground; there is increased risk of objects being thrown from rotating equipment when working in these conditions.*
- ⚠ The machine can be used on slopes up to a maximum of 55° (track option dependant) providing the surface is dry and firm.*
- ⚠ Should a machine overturn, a suitable crane or winch should be used to recover it; keep all persons at a safe distance before and during recovery.*
- ⚠ Do not operate the machine in foggy or frosty conditions as there is increased risk of accidents.*
- ⚠ Take extra care when working in close proximity to electrical cables; in some circumstances, operating the machine under overhead power lines can result in loss of radio signal causing the engine to be deactivated.*
- ⚠ Do not operate the machine close to vehicles or properties where there is risk of damage by objects accidentally ejected from certain types of mounted equipment.*
- ⚠ It is the user's responsibility to protect persons in or near the work zone.*
- ⚠ When servicing or maintaining the machinery no-one should be allowed beneath it when it is raised unless it is securely supported on suitable ramps or stands.*
- ⚠ Never attempt to service or maintain the machine whilst it is running; always switch off the engine and remove the isolator key.*

- ⚠ *When transporting the machine on another vehicle or trailer the engine must be switched off and the machine chocked and secured with suitable ropes or chains.*
- ⚠ *Check the condition of any flails or other mounted tools and their fixings on a regular basis; never use a machine with damaged or missing flails/tools or loose fixings.*
- ⚠ *Always clean the machine after use; if machine components are hot allow them to cool to a safe temperature before cleaning. Never use solvent based chemicals for cleaning.*
- ⚠ *When operating in excessively dusty conditions the machine may need to be stopped on a regular basis to remove any build ups of dust on components that could cause overheating; switch the engine off and beware of hot components.*
- ⚠ *Ensure engine is switched off and Emergency Stop switch is in the 'off' position before refuelling.*
- ⚠ *Wherever possible refuel the machine before work when the engine is cold. If refuelling during work, switch off the engine and allow it to cool before adding fuel.*
- ⚠ *Test the Emergency Stop buttons before each period of work to ensure they function correctly.*
- ⚠ *Never leave the machine, isolator key and control unit unattended in one place; the machine could be started and used by un-authorized persons.*
- ⚠ *Any inspection, service or maintenance of the machine and attached equipment must only be performed with machine switched off and the isolator key removed.*
- ⚠ *Always wear suitable safety gear at all times when performing service or maintenance work on the machine or any mounted equipment.*
- ⚠ *Mounted equipment must always be switched off when manoeuvring outside of the work zone.*

### Personal Protective Equipment (PPE)

We recommend that the following personal protective equipment is worn during operation and/or maintenance of this machinery; overalls, safety shoes, safety goggles, ear protection, safety helmet, protective gloves, respiratory protection, shin/knee protection.



Although the information stated here covers a wide range of safety subjects, it is impossible to predict every eventuality that can occur under differing circumstances whilst operating this machine. No advice given here can replace 'good common sense' and 'total awareness' at all times, but it will go a long way towards the safe use of your McConnel machine.



Operating, servicing and maintaining this equipment can expose you to chemicals including gasoline, diesel fuel, lubricants, petroleum products, engine exhaust, carbon monoxide, and phthalates, which are known to the State of California to cause cancer and birth defects or other

reproductive harm. To minimize exposure, avoid breathing exhaust, do not idle the engine except as necessary, service your vehicle in a well-ventilated area and wear gloves or wash your hands frequently when servicing your vehicle. Battery posts, terminals and related accessories contain lead and lead compounds, chemicals known to the state of California to cause cancer, birth defects or other reproductive harm. For more information go to [www.P65Warnings.ca.gov](http://www.P65Warnings.ca.gov). This website, operated by California's Office of Environmental Health Hazard Assessment, provides information about these chemicals and how individuals may be exposed to them.

## SAFETY DECALS

The safety decals shown below are displayed on this machine; ensure you understand the meaning of these decals and heed their warning.



1. **WARNING!**  
Read the **Book First.**
2. **DANGER!**  
Rotating components;  
keep clear when the  
machine is running.
3. **DANGER!**  
Thrown object risk.  
Keep your distance.

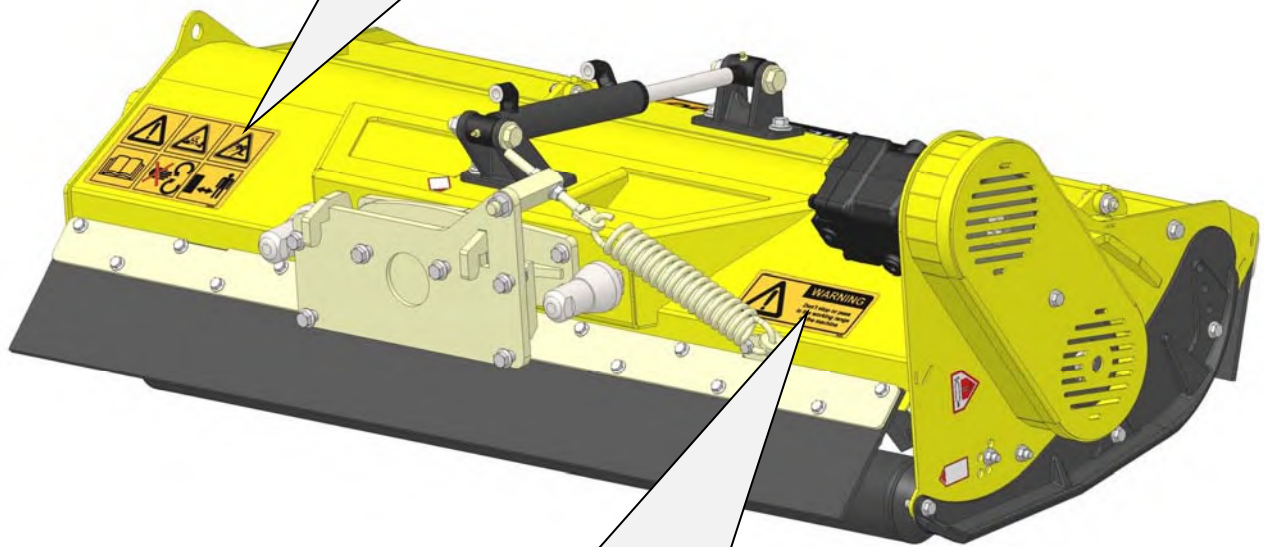

These safety decals must be displayed on the machine and kept in good readable condition; if safety decals are found to be missing or become damaged or illegible they should be replaced immediately, the part numbers for replacements are shown below.



*Part Number: 4500768*



*Part Number: 4500771*

## ATTACHING THE FLAILHEAD



**WARNING**

Attachment of the flailhead should be performed on a firm level site. Ensure all bystanders are kept at a safe distance from machinery.



Keep hands clear of potential pinch points when attaching machinery. Suitable personal protection gear should be worn when working with machines.

### Attachment Procedure



**Tools required;** 19mm spanner

1) Position Robocut 'square and central' to the flailhead.

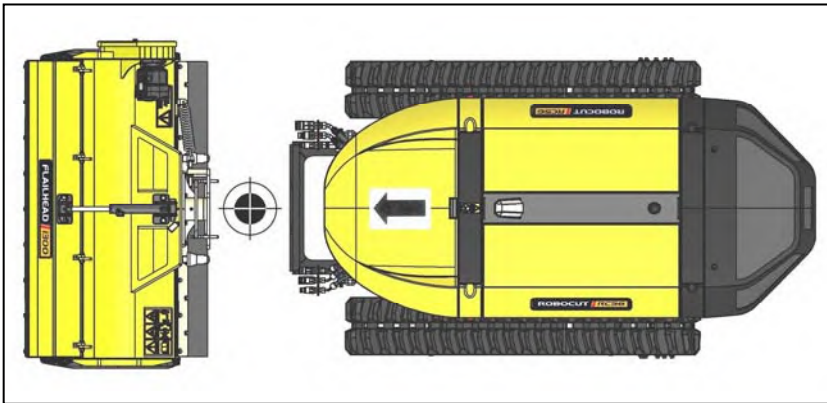

2) Remove flailhead fixings.

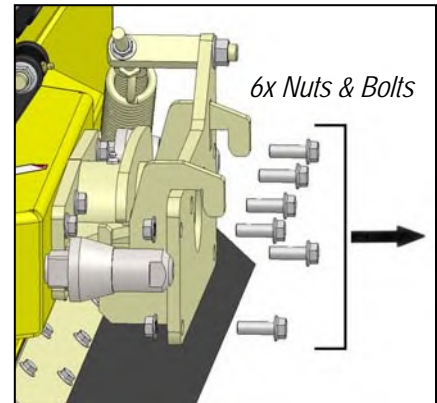

3) Lower Robocut toolbar to a height that is lower than the lugs on flailhead mounting bracket.

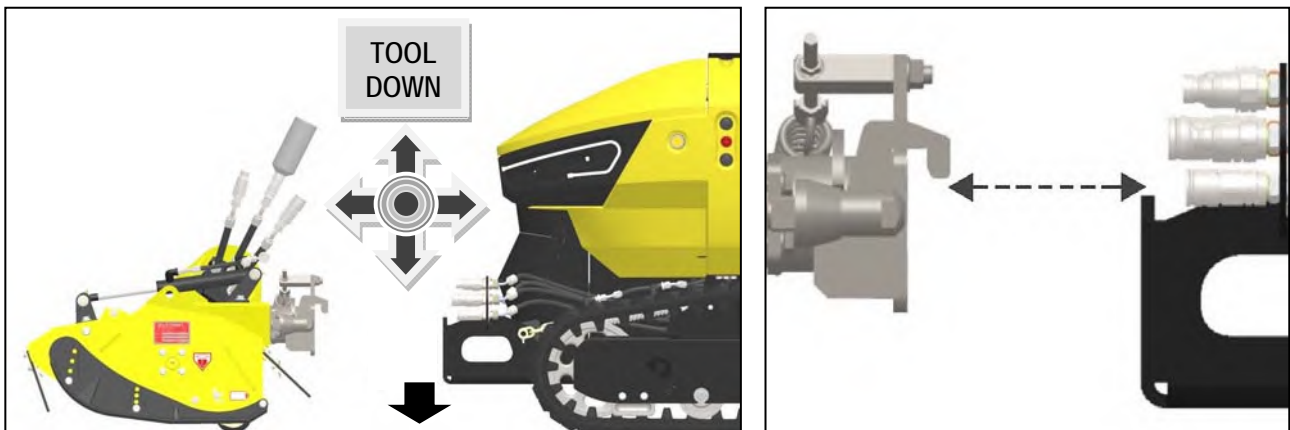

4) Drive Robocut slowly forwards until it is in contact with the flailhead mounting bracket.



5) Raise Robocut toolbar to connect with lugs on flailhead mounting bracket.



6) Fasten flailhead to Robocut toolbar using flailhead fixings (6x Nuts & Bolts) - tighten fixings fully.

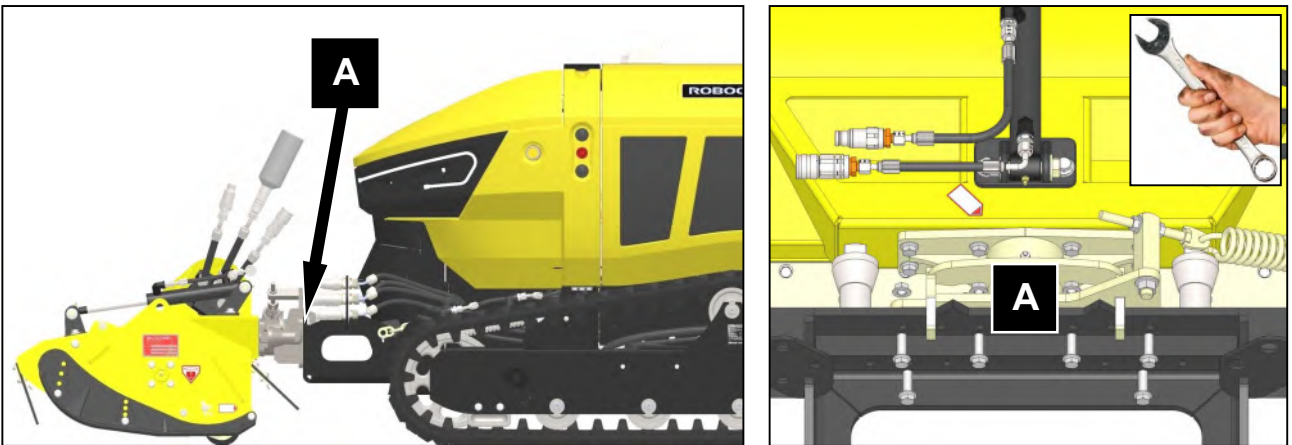

7) Remove expansion vessel from drain line and connect flailhead hoses to the Robocut hydraulics.

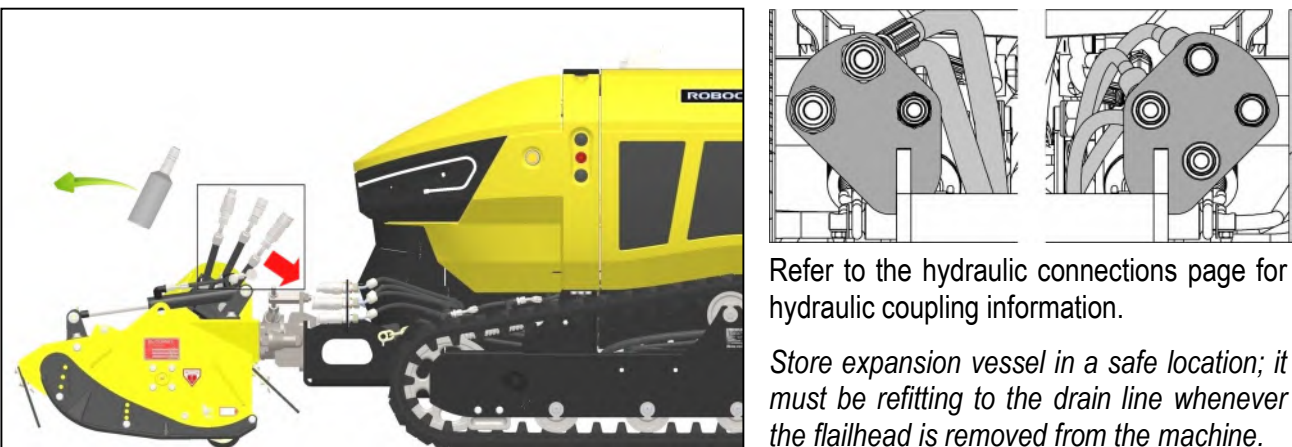

8) Configure the following settings in the Robocut control panel:

**Attachment Settings;** attachment type & width.



Refer to Robocut operator manual for information on configuring these settings

**Float Settings;** float calibration (initial install only).

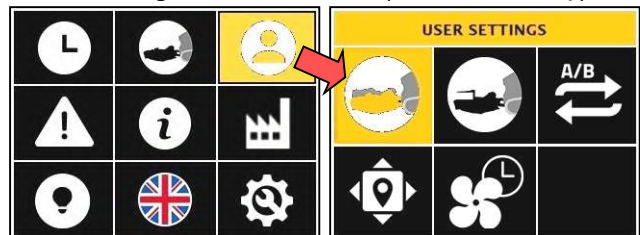

### Removing the Flailhead

Removal of the flailhead is a reversal of the attachment procedure. Select a firm level site on which to remove and store the flailhead.

# HYDRAULIC CONNECTIONS

## Robocut Hydraulic Connection Points

Robocut hydraulic connection points for flailhead attachment.

**CAUTION** Ensure hydraulic couplings on the machine and the attachment are free from dirt or debris – check and clean all couplings prior to connection.

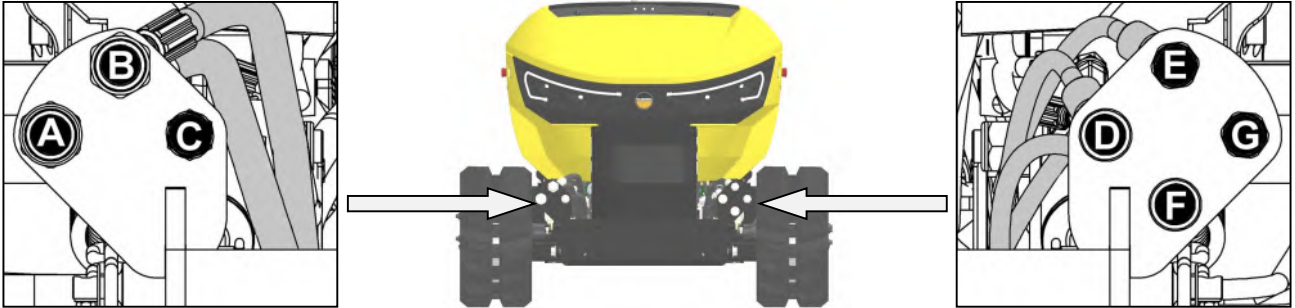

- A. Pressure 'A'
- B. Pressure 'B'
- C. Drain line

**When removing flailhead from machine ensure that expansion vessel is fitted to the flailhead drain line hose.**

- D. Hood Ram (Base)
- E. Hood Ram (Gland)
- F. & G. Auxiliary use only

Ensure that the hydraulic hoses for the hood ram are attached to the correct connection points (D & E) as indicated in the diagram above. The pressure and drain line hoses (A, B & C) can only be attached on their corresponding connections. Connections F & G are reserved for auxiliary use.

## Flailhead Hose Connection

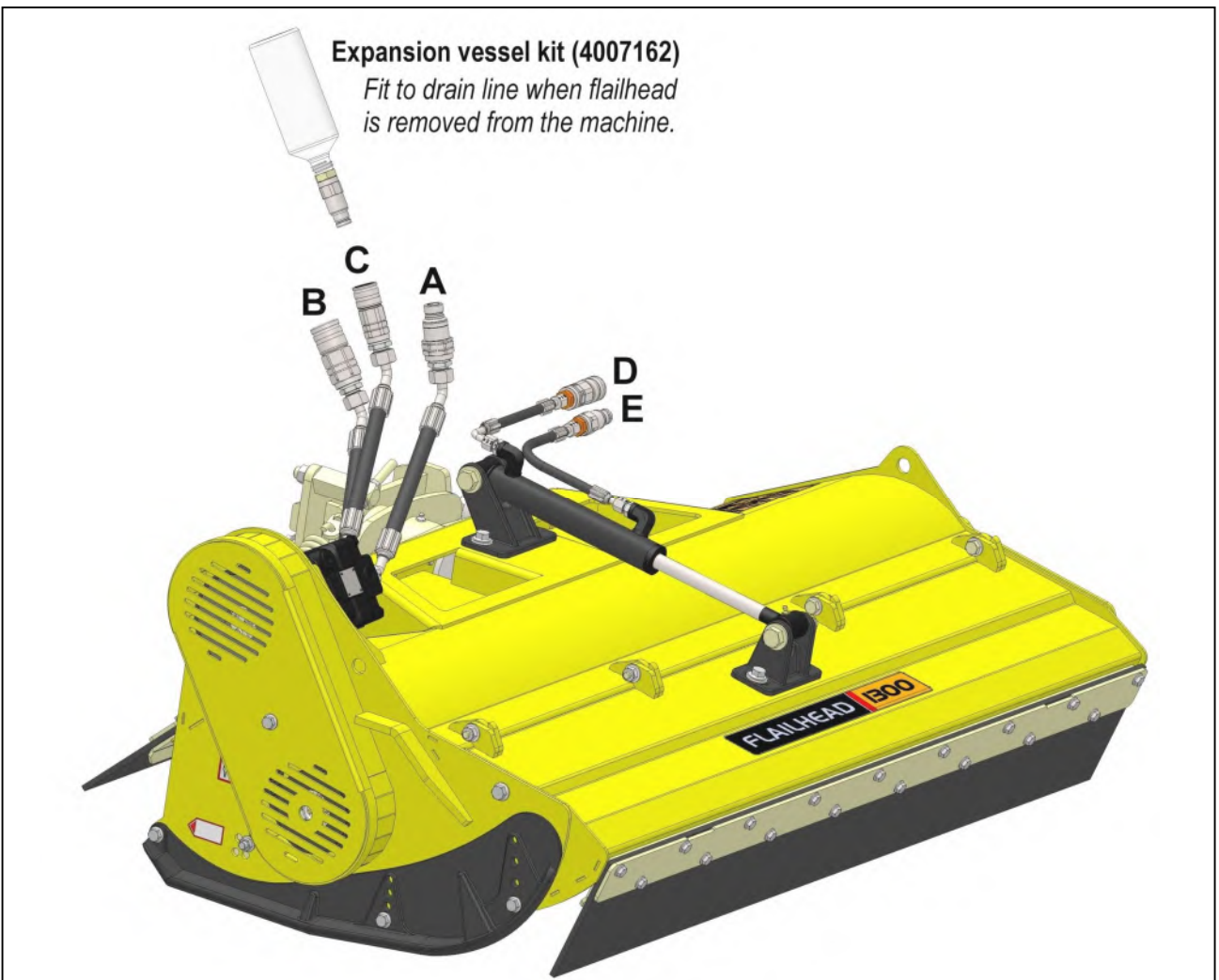



# FLAILHEAD CONTROLS

**⚠ DANGER**

Operators must wear personal safety gear at all times whilst operating the machine and stand in a safe operating position with a clear view of the machinery and the work area.

## Controls Identification for Flailhead Operation

Refer to Robocut manual for full details of machine controls.

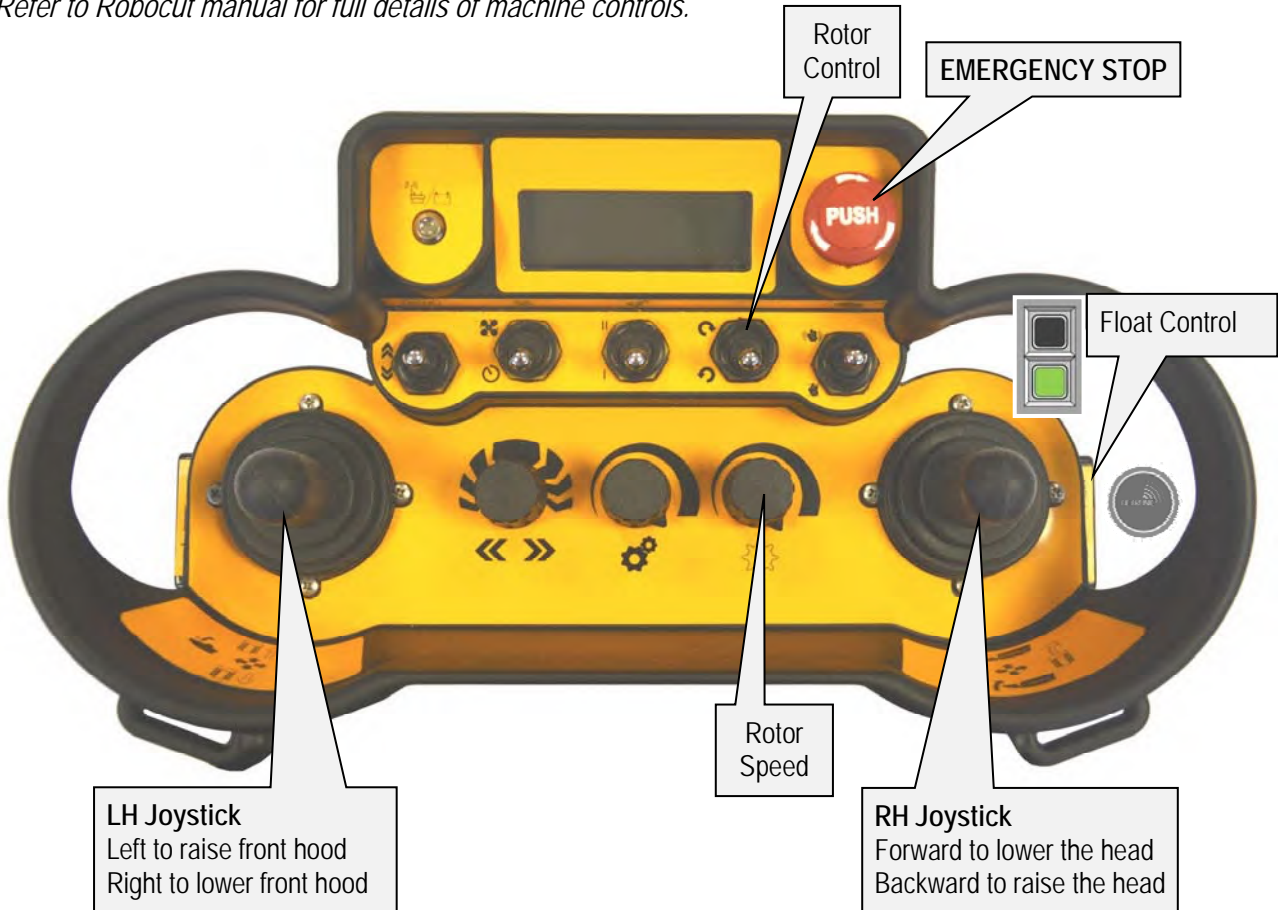

## Joystick Controls for Flailhead Operation (Default)

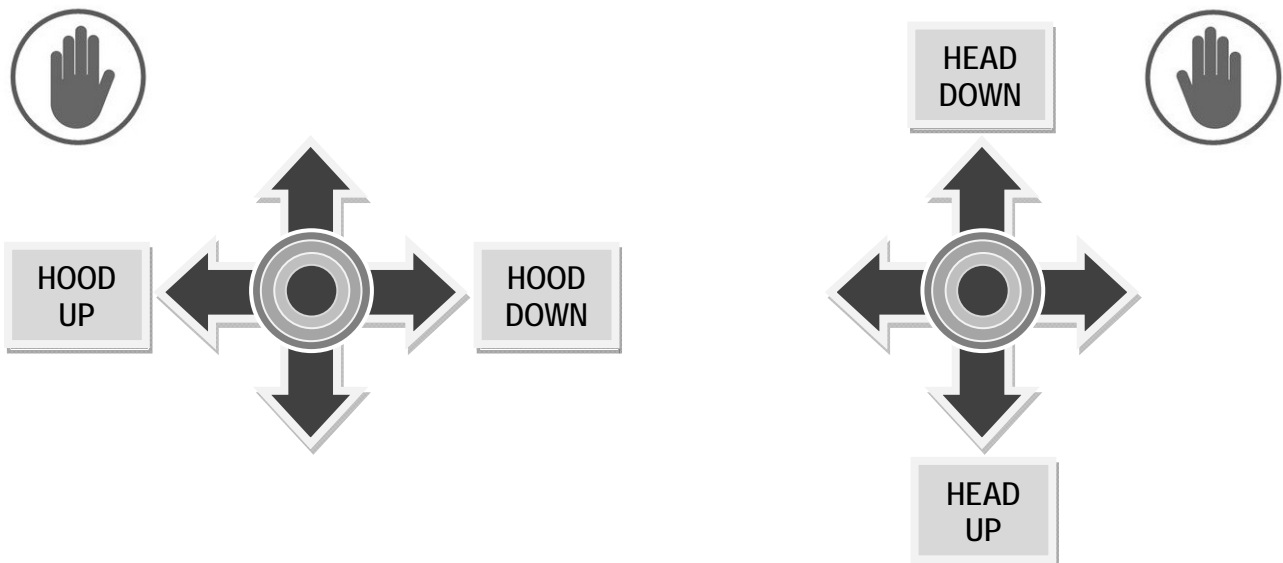

## Control Unit – Display Screen & Flailhead Function Operation

### LCD Display

Reports the following information;



### Status Light

Indicates the status of the Remote Control Unit;

Illuminated **GREEN** = 'CORRECT' Status.

Illuminated **RED** = 'PROBLEM' Status.

### Emergency Stop Button

'Push' button for 'EMERGENCY STOP'

Rotate clockwise to 'Reset'

### Rotor Control Switch

Rotor direction ON and OFF control;



**Rotor ON (Uphill):** Place switch in 'UP' position to start the rotor 'uphill'



**Rotor OFF:** Place switch in the central position to 'STOP' rotor



**Rotor ON (Downhill):** Place switch in 'DOWN' position to start the rotor 'downhill'

### Rotor RPM Control Dial (Potentiometer)

Controls the rotor speed;



**Increase Rotor RPM:** Rotate control dial clockwise

**Decrease Rotor RPM:** Rotate control dial anti-clockwise



### Float Control Button

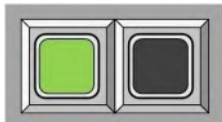

Press **AUX** Button: Activation/deactivation of 'float' feature.



The control information shown in this manual relates to operation of the flailhead only; for details of all controls refer to the Robocut operation manual.

## FRONT HOOD

The flailhead is fitted with a hydraulic ram to allow movement of the hinged hood, by default on every start-up movement of this ram is electronically deactivated to stop operators inadvertently opening the hood when cutting alongside the highway; this reduces the risk to passing traffic from being hit by objects ejected at speed from the working flail head. It should be noted that with the hinged hood opened objects could be thrown a considerable distance. Being struck by a thrown object could result in injury or death.

If the machine is being used away from the highway, where other vehicles and bystanders are not normally in the vicinity, the hood ram function may be activated provided the general safety information and following specific conditions are met;

- A detailed work area and bystander risk assessment is undertaken before work begins.
- The operator has been trained in the safe use of the Robocut.
- All pre-work checks stated in the Robocut operation manual have been fully performed.

**Refer to the Robocut operation manual for details of hood activation/deactivation.**

### Hood Operation

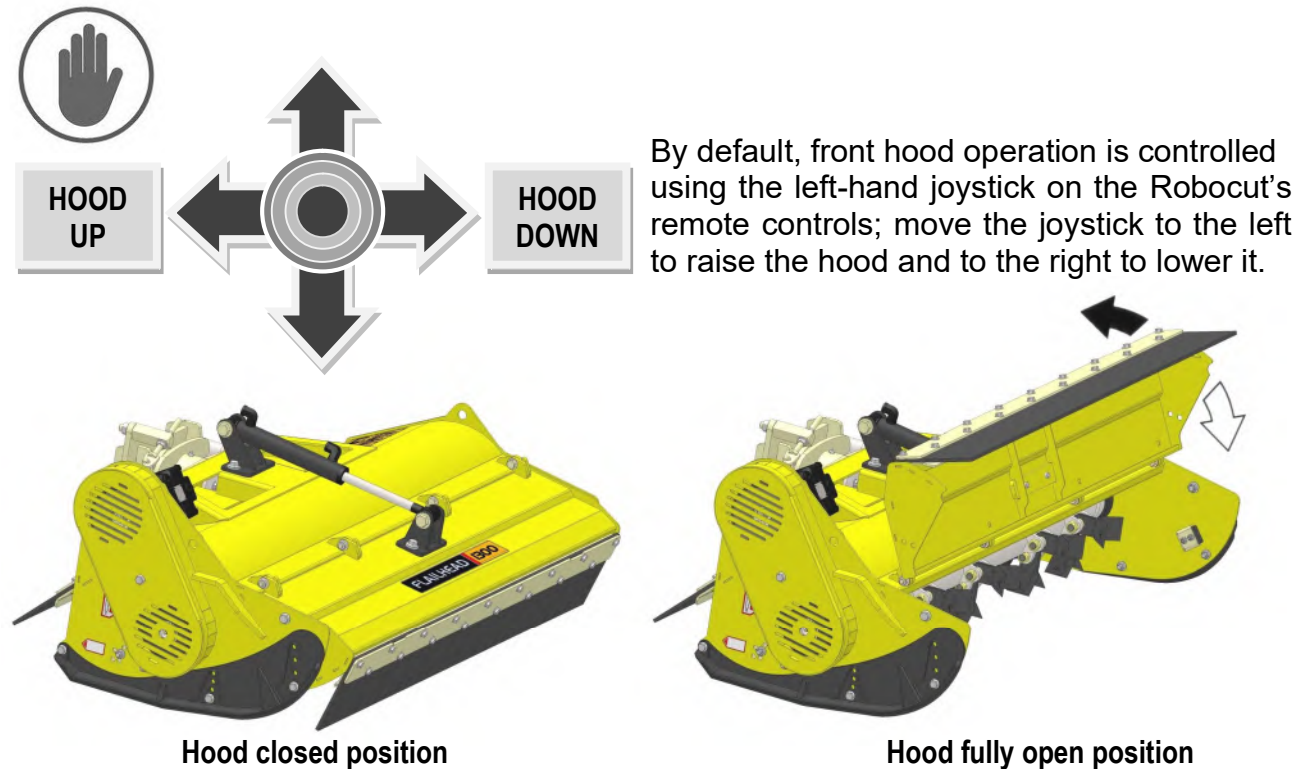

The hood is capable of being raised to any position between fully closed and fully open. When operating the machine with the hood open, it should only be raised to a position that is slightly above the height of the material being cut; this will allow material to freely enter the head whilst offering maximum possible protection. Always close the hood fully before stopping the machine.

### **⚠ DANGER**

**The machine must only be operated with the hood raised when all safety conditions for working with the machine in this mode have been met; if safety doubts exist, the machine must only be used with the hood fully closed.**

## REAR ROLLER & SIDE SKIDS

Adjustment of the rear roller and side skids should be performed on a firm level site.

### Cutting Height

The cutting height of the flailhead is governed by the height position of the rear roller; to alter the cutting height the mounting position of the roller brackets must be adjusted.

5 hole positions in the side casing and 2 in the brackets provide for a range of roller height settings; lowering the roller position raises the cutting height and raising the roller will lower the cutting height. *Ensure matching hole positions are selected on each side of the head.*

### Roller Height Adjustment



**Tools required;** 2x 17mm spanners or sockets

Setting the cutting height requires removal of the rearmost fixing bolts of the roller brackets on each side of the head and subsequent replacement with the roller brackets set at the required cutting height position; *the front fixing bolts will require 'slackening off' to allow the rear of the brackets to be moved.*

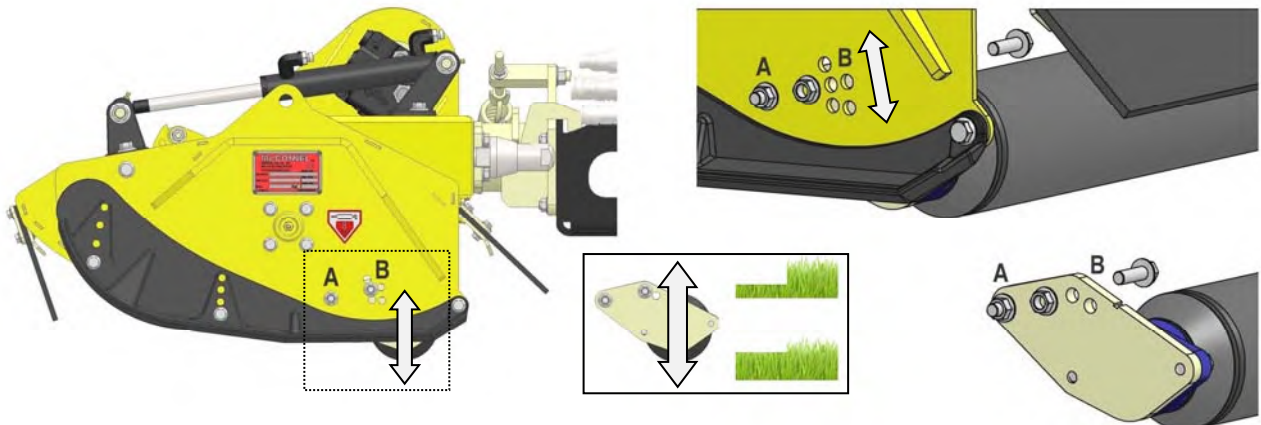

Loosen bolts 'A' and remove bolts 'B'; set desired roller height and replace bolts 'B'. Tighten all bolts fully.

### **⚠ WARNING**

**Never use the machine with the rear roller removed.**

### Skid Height Adjustment

Side skids should be set to a height just above that of the rear roller. Skids are a protection feature that restrict cutting debris and/or objects from being ejected under the side casings; in normal working conditions they should remain clear of the ground with the machine running on the rear roller. When setting the skids, ensure they are set at a matching height on each side of the head.

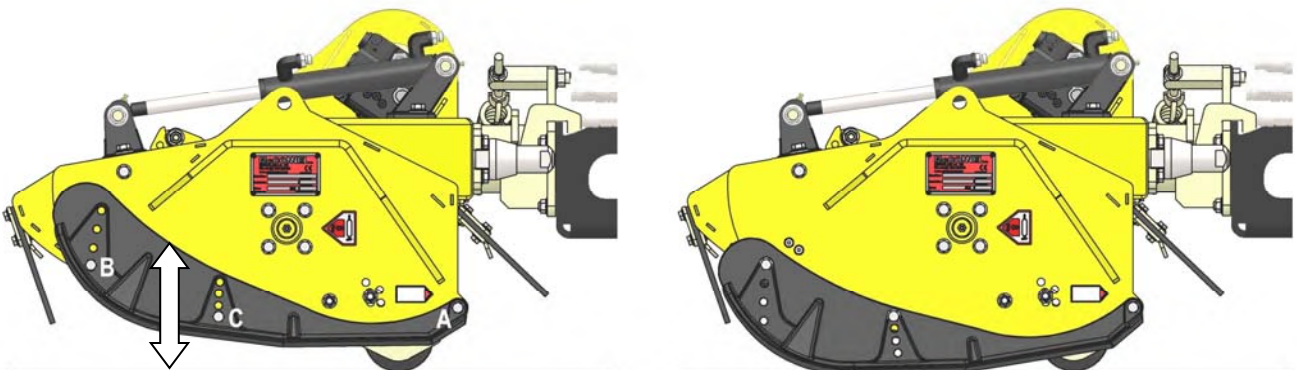

Loosen bolts 'A' and remove bolts 'B' & 'C'; set skid height and replace bolts 'B' & 'C'. Tighten all bolts fully

## FLOAT & ANGLE

---

### Float Function

When activated, the float function allows the flailhead to follow the contours of the ground. The response speed of float is adjustable and can be set to LOW, MEDIUM or HIGH. By default, the function float is pre-set to 'LOW' - this is the recommended setting for normal work and conditions. *Refer to Robocut operation manual for details on changing float settings for the attachment.*

On initial installation, the Robocut must first calibrate the float function; *refer to Robocut operation manual for full details of the calibration procedure.*

Float calibration for the flailhead will only need to be performed on initial attachment to the machine; float settings will then remain in the machines system memory even if the flailhead is subsequently removed from the machine and re-mounted at a later date.

### Head Angle

In addition to float, the flailhead also features an 'angle' capability that permits the flailhead to angle itself independently of the machine by  $\pm 14^\circ$ ; this will allow the flailhead freedom to follow undulating terrain for more accurate cutting.

## ROTOR OPERATION

---

### Rotor Direction

For grass cutting with Y-flails the rotor can be operated in either 'uphill' or 'downhill' cutting direction; uphill is usually the preferred choice for best cutting results but downhill can be used where circumstance or conditions demand.

Machines equipped with hammer flails should be operated in the 'uphill' direction only.

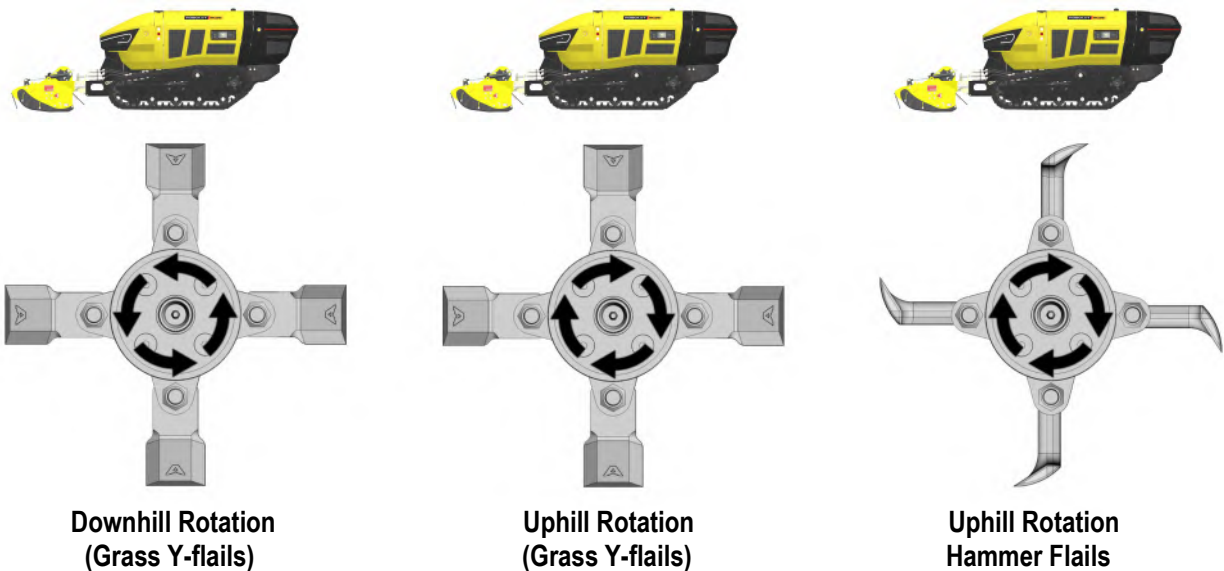

### Rotor Speed

Rotor speed will vary depending on the conditions and the materials being cut, but should fall within the range of 2000-2800 rpm.

### Damaged or Missing Flails

#### **CAUTION**

Do not operate the machine with broken or missing flails; this will cause rotor imbalance.

# ROTORS & FLAILS

## Rotor and Flail Identification

1.3m Grass Rotor (22 Station)  
Y-Flails

1.6m Grass Rotor (30 Station)  
Y-Flails

1.9m Grass Rotor (38 Station)  
Y-Flails

1.3m Grass Rotor (22 Station)  
Hammer Flails

1.6m Grass Rotor (30 Station)  
Hammer Flails

1.9m Grass Rotor (38 Station)  
Hammer Flails

Torque flail bolts to 80 Nm



### Hammer Flail Kit (4007158)

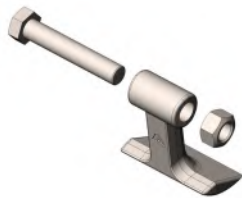

- 1x Hammer Flail (4501091)
- 1x Bolt (4007155)
- 1x Nut (05.968.06)

### Y-Flail Kit (4007152)



- 2x Y-Flail (4007153)
- 2x Spacer (4007154)
- 1x Bolt (4007155)
- 1x Nut (05.968.06)

### Bare Rotor Part Numbers

- 4007156: 1.3m Rotor
  - 4007023: 1.6m Rotor
  - 4007038: 1.9m Rotor
- Rotors are the same for both types of flails.*

## DRIVE BELT



**WARNING** Machinery must be switched off and the main isolator key removed before attempting to inspect or access the belt drive housing.

### Drive Belt Checks



**Tools required;** 17mm spanner

The machines drive belt should be inspected regularly and checked for signs of wear or loss of tension. Access to the belt and pulley's is via the removable belt cover on the side of the drive housing.

The drive belt must be replaced immediately if it shows signs of excessive wear or damage, or fails to tension correctly.

Clean the belt drive housing and cover vents to remove any dirt or dust build-up before replacing the belt cover.

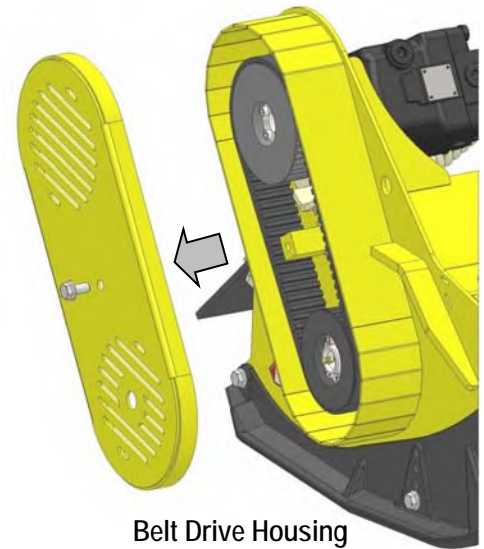

Belt Drive Housing

### Belt Tension

Belt tension setting is; 9mm deflection at mid-point of belt run under 5 Kgs (10lbs) of force. Avoid over-tensioning the belt as this can cause excessive wear on main drive bearings.

### Adjusting Belt Tension

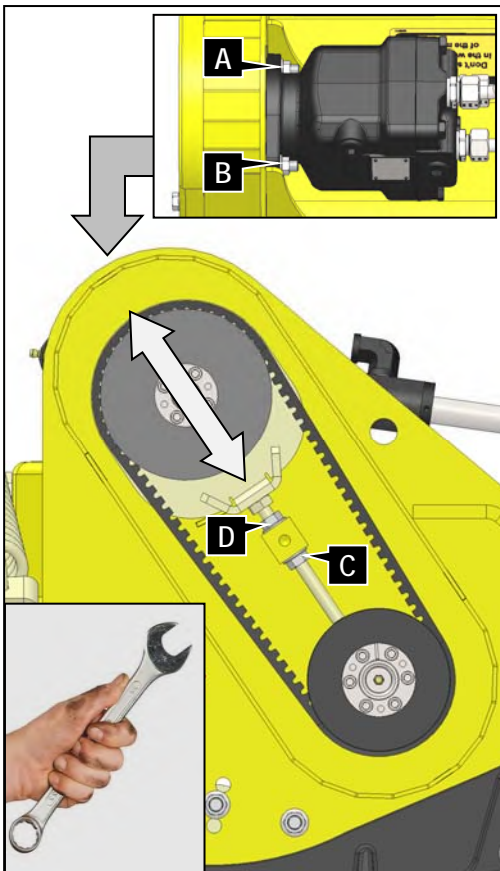

Drive Belt Adjuster

#### *Belt tensioning procedure:*

- Remove belt cover.
- Slightly loosen motor mounting nuts 'A' & 'B'.
- Release locking nut 'C'.
- Tension belt using adjuster nut 'D'.
- Retighten locking nut 'C'.
- Retighten motor mounting nuts 'A' & 'B'.
- Replace belt cover.

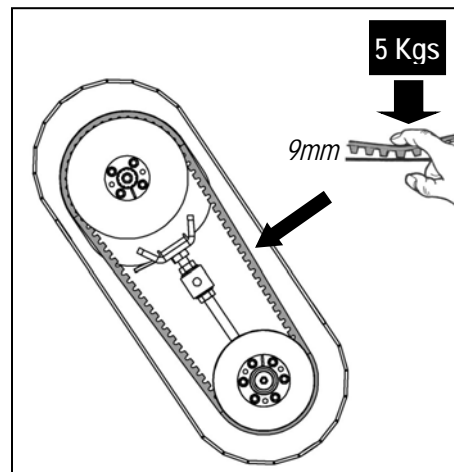

Belt Tension Setting



**WARNING** Never start or operate the machine with the belt cover removed.

## Belt Pulley Alignment

The belt pulleys are secured in position on their shafts by taperlock bushings; when replacing pulleys the lower pulley must be fitted to the rotor shaft first, the pulley and taperlock should be located as far as possible onto the shaft at a minimal distance from casing components and secured with the taperlock.

The upper pulley and taperlock should be subsequently fitted to the drive shaft and positioned in-line with the lower pulley; a suitable straight edge tool placed against the faces of both pulleys should be used to set and confirm alignment.

When the pulleys have been correctly installed the taperlocks must be fully tightened and torqued, refer to taperlock tightening procedure below.

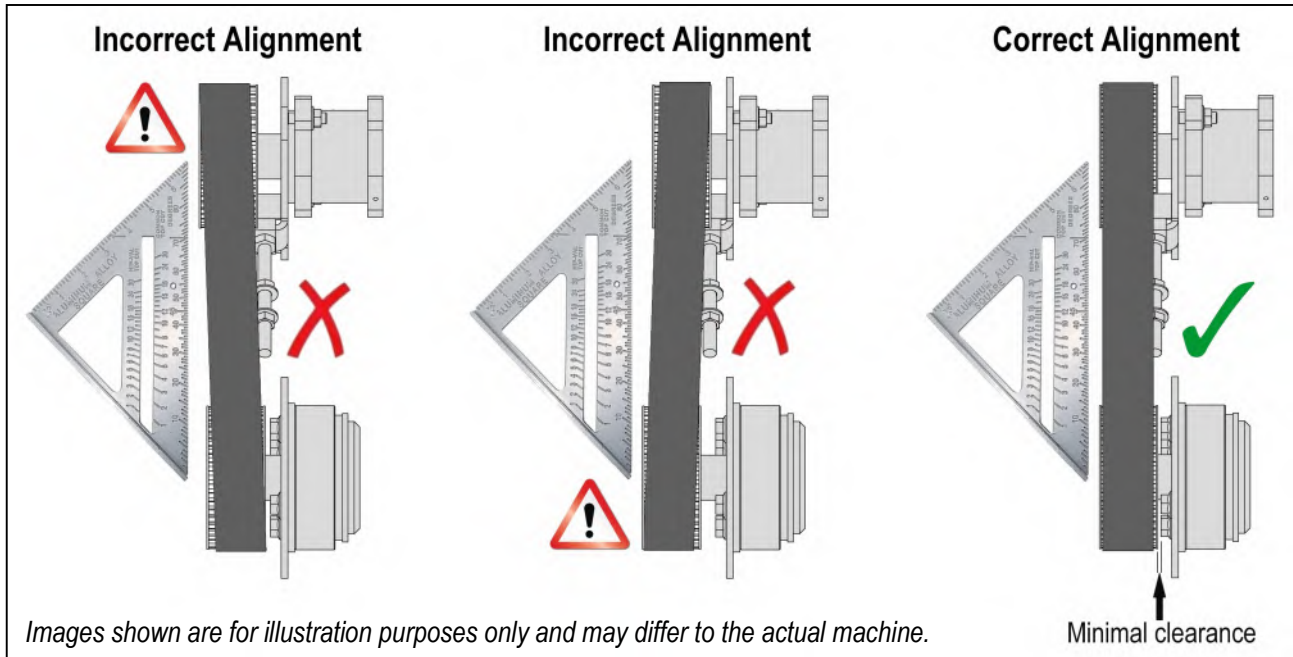

## Taperlocks

The pulley taperlocks must be tightened and torqued to **17Nm** (12.5 ft-lb). Tighten the 6 Allen headed bolts using a criss-cross tightening sequence to the torque figure stated; repeat the tightening procedure twice on each taperlock.

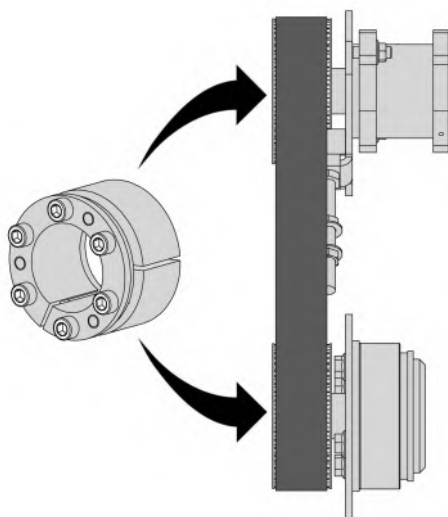

Taperlock locations

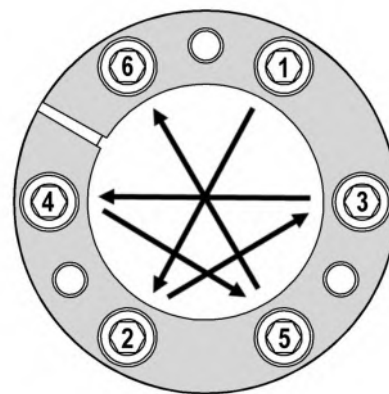

Taperlock Tightening Sequence

## CAUTION

Check tightness of taperlocks after an initial 2 hours of use and every 25 hours thereafter.



## GENERAL MAINTENANCE

### Machine Lubrication

Lubricate grease points indicated below using a good quality lithium-based grease.

### Grease Point Locations

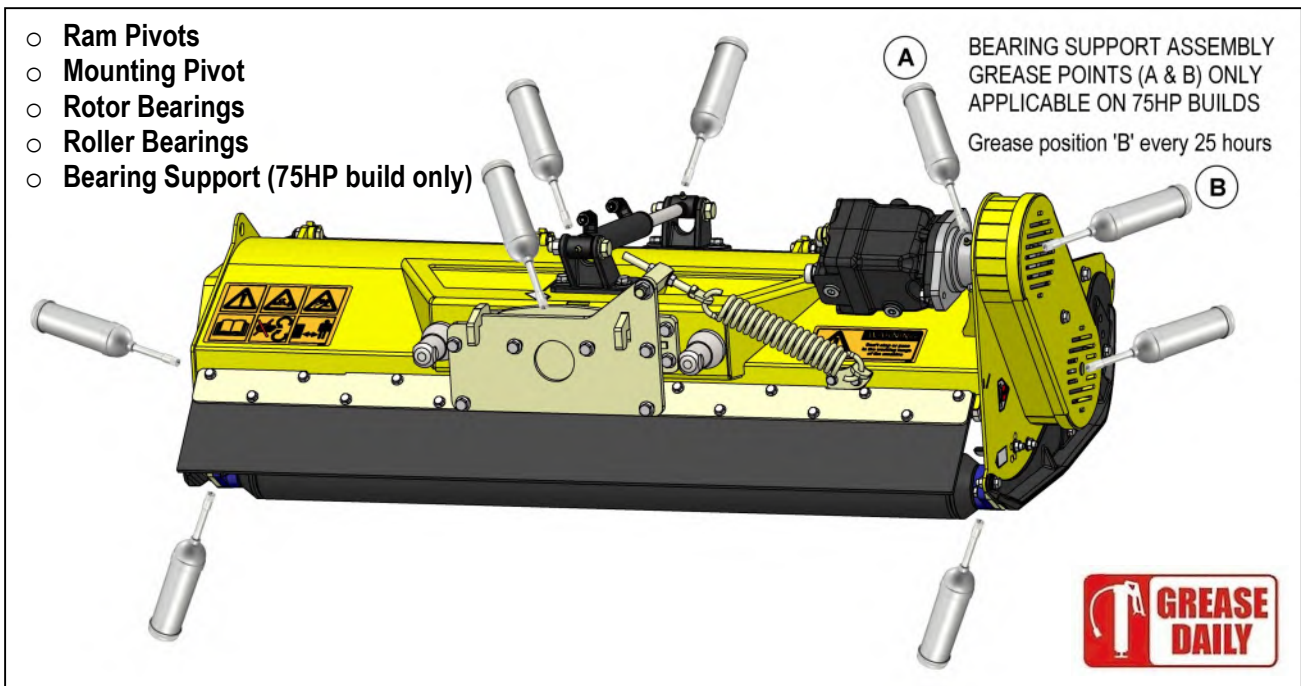

### New Machines – Initial Checks

After the **first 2 hours of use** the following points should be checked on new machines.

- Check tightness of all nuts, bolts, and fixings; *tighten if required*.
- Check belt tension; *tighten if required*.
- Check tightness of taperlocks; *re-torque if required*.

### Daily Checks

Machine should be inspected each day prior to work and at regular intervals during work.

- Check condition of flails and tightness of fixings; *missing or damaged flails must be replaced before using the machine*.
- Check tightness of all nuts, bolts, and fixings; *tighten if required*.
- Check hydraulic hoses for leaks and/or damage; *replace if required*.
- Lubricate grease points; *refer to grease point diagram above*.

### 25 Hour Checks

- Check condition and tension of drive belt; *tension belt if required*.
- Check tightness of taperlocks; *re-torque if required*.
- Lubricate bearing support spline shaft.

**NOTE:** Access to these components requires removal of the belt cover; replace belt cover before attempting to start or use the machine.

## **▲WARNING**

**Machinery must be switched off and the main isolator key removed before performing checks.**



McConnel Limited, Temeside Works, Ludlow, Shropshire SY8 1JL. England.  
Telephone: 01584 873131. Facsimile: 01584 876463. [www.mcconnel.com](http://www.mcconnel.com)