

Publication 1039
November 2022
Part No. 24215.39



McCONNEL

CUTTERBAR (HD)

ROBOCUT ATTACHMENT

4000970

Operation Manual



IMPORTANT

VERIFICATION OF WARRANTY REGISTRATION



Dealer Warranty Information & Registration Verification

It is imperative that the selling dealer registers this machine with McConnel Limited before delivery to the end user – failure to do so may affect the validity of the machine warranty.

To register machines; log onto <https://my.mcconnel.com> and select 'Machine Registration' which can be found in the 'Warranty' section of the site. **Confirm to the customer that the machine has been registered by completing the verification form below.**

Registration Verification	Serial No. <input type="text"/>
Dealer Name:	
Dealer Address:	
Customer Name:	
Date of Warranty Registration:/...../..... Dealer Signature:	

Note to Customer / Owner

Please ensure the section above has been completed and signed by the dealer to verify your machine has been registered with McConnel Limited.

IMPORTANT: During the initial 'bedding in' period of a new machine it is the customer's responsibility to regularly inspect all nuts, bolts and hose connections for tightness and re-tighten if required. New hydraulic connections occasionally weep small amounts of oil as the seals and joints settle in – where this occurs it can be cured by re-tightening the connection – *refer to torque settings chart below*. The tasks stated above should be performed on an hourly basis during the first day of work and at least daily thereafter as part of the machine's general maintenance procedure.

CAUTION: DO NOT OVER TORQUE HYDRAULIC FITTINGS AND HOSES

Torque Settings for Hydraulic Fittings

Hydraulic Hose Ends		
BSP	Setting	Metric
1/4"	18 Nm	19 mm
3/8"	31 Nm	22 mm
1/2"	49 Nm	27 mm
5/8"	60 Nm	30 mm
3/4"	80 Nm	32 mm
1"	125 Nm	41 mm
1.1/4"	190 Nm	50 mm
1.1/2"	250 Nm	55 mm
2"	420 Nm	70 mm

Port Adaptors with Bonded Seals		
BSP	Setting	Metric
1/4"	34 Nm	19 mm
3/8"	47 Nm	22 mm
1/2"	102 Nm	27 mm
5/8"	122 Nm	30 mm
3/4"	149 Nm	32 mm
1"	203 Nm	41 mm
1.1/4"	305 Nm	50 mm
1.1/2"	305 Nm	55 mm
2"	400 Nm	70 mm

WARRANTY POLICY

WARRANTY REGISTRATION

All machines must be registered, by the selling dealer with McConnel Ltd, before delivery to the end user. On receipt of the goods it is the buyer's responsibility to check that the Verification of Warranty Registration in the Operator's Manual has been completed by the selling dealer.

1. LIMITED WARRANTIES

1.01. *All mounted machines supplied by McConnel Ltd are warranted to be free from defects in material and workmanship from the date of sale to the original purchaser for a period of 12 months, unless a different period is specified.*

All Self Propelled Machines supplied by McConnel Ltd are warranted to be free from defects in material and workmanship from the date of sale to the original purchaser for a period of 12 months or 1500 hours. Engine warranty will be specific to the Manufacturer of that unit.

1.02. *All spare parts supplied by McConnel Ltd and purchased by the end user are warranted to be free from defects in material and workmanship from the date of sale to the original purchaser for a period of 6 months. All parts warranty claims must be supported by a copy of the failed part invoice to the end user. We cannot consider claims for which sales invoices are not available.*

1.03. *The warranty offered by McConnel Ltd is limited to the making good by repair or replacement for the purchaser any part or parts found, upon examination at its factory, to be defective under normal use and service due to defects in material or workmanship. Returned parts must be complete and unexamined. Pack the component(s) carefully so that any transit damage is avoided. All ports on hydraulic items should be drained of oil and securely plugged to prevent seepage and foreign body ingress. Certain other components, electrical items for example, may require particular care when packing to avoid damage in transit.*

1.04. *This warranty does not extend to any product from which McConnel Ltd's serial number plate has been removed or altered.*

1.05. *The warranty policy is valid for machines registered in line with the terms and conditions detailed and on the basis that the machines do not extend a period of 24 months or greater since their original purchase date, that is the original invoice date from McConnel Limited.*

Machines that are held in stock for more than 24 months cannot be registered for warranty.

1.06. *This warranty does not apply to any part of the goods, which has been subjected to improper or abnormal use, negligence, alteration, modification, fitment of non-genuine parts, accident damage, or damage resulting from contact with overhead power lines, damage caused by foreign objects (e.g. stones, iron, material other than vegetation), failure due to lack of maintenance, use of incorrect oil or lubricants, contamination of the oil, or which has served its normal life. This warranty does not apply to any expendable items such as blades, belts, clutch linings, filter elements, flails, flap kits, skids, soil engaging parts, shields, guards, wear pads, pneumatic tyres or tracks.*

1.07. *Temporary repairs and consequential loss - i.e. oil, downtime and associated parts are specifically excluded from the warranty.*

1.08. *Warranty on hoses is limited to 12 months and does not include hoses which have suffered external damage. Only complete hoses may be returned under warranty, any which have been cut or repaired will be rejected.*

1.09. *Machines must be repaired immediately a problem arises. Continued use of the machine after a problem has occurred can result in further component failures, for which McConnel Ltd cannot be held liable, and may have safety implications.*

1.10. *If in exceptional circumstances a non McConnel Ltd part is used to effect a repair, warranty reimbursement will be at no more than McConnel Ltd's standard dealer cost for the genuine part.*

- 1.11. *Except as provided herein, no employee, agent, dealer or other person is authorised to give any warranties of any nature on behalf of McConnell Ltd.*
- 1.12. *For machine warranty periods in excess of 12 months the following additional exclusions shall apply:*
 - 1.12.1. *Hoses, exposed pipes and hydraulic tank breathers.*
 - 1.12.2. *Filters.*
 - 1.12.3. *Rubber mountings.*
 - 1.12.4. *External electric wiring.*
 - 1.12.5. *Bearings and seals*
 - 1.12.6. *External Cables, Linkages*
 - 1.12.7. *Loose/Corroded Connections, Light Units, LED's*
 - 1.12.8. *Comfort items such as Operator Seat, Ventilation, Audio Equipment*
- 1.13. *All service work, particularly filter changes, must be carried out in accordance with the manufacturer's service schedule. Failure to comply will invalidate the warranty. In the event of a claim, proof of the service work being carried out may be required.*
- 1.14. *Repeat or additional repairs resulting from incorrect diagnosis or poor quality previous repair work are excluded from warranty.*

NB Warranty cover will be invalid if any non-genuine parts have been fitted or used. Use of non-genuine parts may seriously affect the machine's performance and safety. McConnell Ltd cannot be held responsible for any failures or safety implications that arise due to the use of non-genuine parts.

2. REMEDIES AND PROCEDURES

- 2.01. *The warranty is not effective unless the Selling Dealer registers the machine, via the McConnell web site and confirms the registration to the purchaser by completing the confirmation form in the operator's manual.*
- 2.02. *Any fault must be reported to an authorised McConnell Ltd dealer as soon as it occurs. Continued use of a machine, after a fault has occurred, can result in further component failure for which McConnell Ltd cannot be held liable.*
- 2.03. *Repairs should be undertaken within two days of the failure. Claims submitted for repairs undertaken more than 2 weeks after a failure has occurred, or 2 days after the parts were supplied will be rejected, unless the delay has been authorised by McConnell Ltd. Please note that failure by the customer to release the machine for repair will not be accepted as a reason for delay in repair or submitting warranty claims.*
- 2.04. *All claims must be submitted, by an authorised McConnell Ltd Service Dealer, within 30 days of the date of repair.*
- 2.05. *Following examination of the claim and parts, McConnell Ltd will pay, at their discretion, for any valid claim the invoiced cost of any parts supplied by McConnell Ltd and appropriate labour and mileage allowances if applicable.*
- 2.06. *The submission of a claim is not a guarantee of payment.*
- 2.07. *Any decision reached by McConnell Ltd. is final.*

3. LIMITATION OF LIABILITY

- 3.01. *McConnell Ltd disclaims any express (except as set forth herein) and implied warranties with respect to the goods including, but not limited to, merchantability and fitness for a particular purpose.*
- 3.02. *McConnell Ltd makes no warranty as to the design, capability, capacity or suitability for use of the goods.*
- 3.03. *Except as provided herein, McConnell Ltd shall have no liability or responsibility to the purchaser or any other person or entity with respect to any liability, loss, or damage caused or alleged to be caused directly or indirectly by the goods including, but not limited to, any indirect, special, consequential, or incidental damages resulting from the use or operation of the goods or any breach of this warranty. Notwithstanding the above limitations and warranties, the manufacturer's liability hereunder for damages incurred by the purchaser or others shall not exceed the price of the goods.*
- 3.04. *No action arising out of any claimed breach of this warranty or transactions under this warranty may be brought more than one (1) year after the cause of the action has occurred.*

4. MISCELLANEOUS

- 4.01. McConnel Ltd may waive compliance with any of the terms of this limited warranty, but no waiver of any terms shall be deemed to be a waiver of any other term.*
- 4.02. If any provision of this limited warranty shall violate any applicable law and is held to be unenforceable, then the invalidity of such provision shall not invalidate any other provisions herein.*
- 4.03. Applicable law may provide rights and benefits to the purchaser in addition to those provided herein.*

McConnel Limited



For Safety and Performance...

ALWAYS READ THE BOOK FIRST



McCONEL LIMITED

**Temeside Works
Ludlow
Shropshire
England**

**Telephone: +44 (0)1584 873131
www.mcconel.com**

**This manual must be read and used in conjunction with:
ROBOCUT Operator Manual**

A copy of Robocut operator manuals are available via the links below;



In line with our policy of constant improvement, this publication will be periodically updated; to ensure you have access to the latest version of this manual please visit the manuals library on our website where an 'up-to-date' version can be referenced online or downloaded.

<https://www.mcconel.com/support/parts-and-operators-manual/>

TABLE OF CONTENTS

1 - GENERAL DESCRIPTION	4
1.1 - PRELIMINARY INFORMATION	4
1.2 - TRAINING REQUIRED FOR THE OPERATOR	5
1.3 - WARNINGS ON USE AND STORAGE	5
1.4 - INTRODUCTION	6
1.4.1 - UPDATING THE MANUAL	6
1.4.2 - COPYRIGHT	6
1.5 - WARRANTIES	6
1.6 - RESPONSIBILITIES	7
1.7 - PERMITTED USES	7
1.8 - IMPROPER OR PROHIBITED USES	8
1.9 - RUNNING-IN AND TESTING OF THE MACHINE	8
1.10 - FOR YOUR SAFETY	9
2 - MACHINE SPECIFICATIONS	10
2.1 - MACHINE DESCRIPTION	10
2.2 - RULES APPLIED	10
2.3 - IDENTIFICATION OF THE EQUIPMENT	11
2.3.1 - DEFINITION OF THE DIRECTIONS OF THE EQUIPMENT	11
2.4 - NOISE LEVEL	12
3 - SAFETY REQUIREMENTS	13
3.1 - GENERAL SAFETY RULES	13
3.1.1 - GETTING TO KNOW THE MACHINE THOROUGHLY	13
3.1.2 - WEAR PROTECTIVE CLOTHING	13
3.1.3 - WARNINGS FOR CHECKS AND MAINTENANCE	13
3.1.4 - CHECKING THE MACHINE	14
3.2 - GENERAL PRECAUTIONS	14
3.2.1 - SAFETY WARNINGS	15
3.2.2 - SAFETY REQUIREMENTS FOR ROAD TRAFFIC CIRCULATION	15
3.2.3 - OPERATIONAL SAFETY	16
3.2.4 - SAFETY RULES WHEN USING THE MACHINE	16
3.2.5 - HYDRAULIC SYSTEM SAFETY REQUIREMENTS	17
3.2.6 - LOCATION OF THE SAFETY PLATES	18
3.2.7 - DESCRIPTION OF THE SAFETY SIGNS	19
3.3 - SAFETY PRECAUTIONS FOR MAINTENANCE	20
3.3.1 - CARE AND MAINTENANCE	20
3.3.2 - WARNING PLATES	21
3.3.3 - TOOLS	21
3.3.4 - PERSONNEL	22
3.3.5 - KEEPING THE MACHINE CLEAN	22
3.3.6 - PERIODIC REPLACEMENT OF ESSENTIAL SAFETY COMPONENTS	22

4 - TECHNICAL DATA 23

4.1 - DIMENSIONS AND WEIGHTS	23
4.2 - TECHNICAL SPECIFICATIONS	24

5 - TERMINOLOGY 25

5.1 - DEFINITION OF THE TERMS USED	25
------------------------------------	----

6 - USE OF THE MACHINE 26

6.1 - PRELIMINARY CHECKS	26
6.2 - CHECKS TO BE PERFORMED AT THE START OF EACH WORKING DAY	26
6.3 - ATTACHING THE EQUIPMENT	27
6.4 - TRANSMITTER UNIT	30
6.4.1 - OPERATING THE TOOL	30
6.4.2 - STOPPING THE TOOL	30
6.4.3 - LIFTING DEVICE	31
6.5 - MOWING	32
6.6 - PROBLEMS, CAUSES AND SOLUTIONS	33

7 - TRANSPORTATION AND HANDLING 34

7.1 - LIFTING	34
---------------	----

8 - STORAGE 35

8.1 - FIRST USE OR RE-COMMISSIONING AFTER A LENGTHY PERIOD OF INACTIVITY	35
8.2 - DISMANTLING, DECOMMISSIONING	36

9 - MAINTENANCE 37

9.1 - INTRODUCTION	37
9.2 - GENERAL RULES	37
9.3 - EXTRAORDINARY INTERVENTIONS	38
9.4 - TABLES FOR THE CHOICE OF FLUIDS	38
9.4.1 - GREASES TABLE	38
9.5 - DAILY MAINTENANCE	38
9.5.1 - CLEANING THE EQUIPMENT	38
9.6 - BLADE MAINTENANCE	39
9.6.1 - CHECKING THE BLADES	39
9.6.2 - BLADE REPLACEMENT	39
9.7 - BLADE HOLDER MAINTENANCE	40
9.7.1 - BLADE HOLDER ADJUSTMENT	40
9.8 - GREASING OF PARTS	41
9.8.1 - CONNECTING ROD UNIT	41
9.8.2 - JOINT ATTACHMENT	41
9.9 - PERIODIC REPLACEMENT OF THE SAFETY COMPONENTS	42
9.10 - MAINTENANCE OPERATIONS	42

10 - INSTRUCTIONS FOR EMERGENCY SITUATIONS	43
10.1 - FIRE	43
11 - TIGHTENING TABLES	44
11.1 - CLASSES OF COARSE PITCH BOLTS	44
11.2 - CLASSES OF FINE PITCH BOLTS	45
11.3 - FITTINGS TIGHTENING TABLE	46
12 - NOTES	47

1 - GENERAL DESCRIPTION

1.1 - PRELIMINARY INFORMATION

This is the instruction manual for use and maintenance of the machine according to:

- Machinery Directive 2006/42/EC and subsequent amendments and additions.
- Statutory instruments 2008 No. 1597.

Do not destroy or modify it and only supplement it with additional files.

Manual code:	Publication 1039
Part No.:	24215.39
Change index:	0
Edition:	09/2022
Machine type:	Mower bar
Model:	CUTTER BAR

The manual is valid from serial number: **M2271834**

McConnel Limited

Temeside Works,
Ludlow, SY8 1JL, UK

Telephone number: +44 (0)1584 873131

Fax: +44 (0)1584 876463

Website address: <https://www.mcconnel.com>

Email: sales@mcconnel.com

1.2 - TRAINING REQUIRED FOR THE OPERATOR

Read this manual thoroughly:

- All machine maintenance personnel must read this entire manual thoroughly and pay maximum attention to its requirements.
- The employer has an obligation to ensure that the operator possesses the required abilities to operate the machine, and that they have read this manual.

1.3 - WARNINGS ON USE AND STORAGE

The operating instructions contained in this manual are valid exclusively for the McConnell machine, model: **CUTTER BAR**.

The instruction manual must be read and used as follows:

- Carefully read the instruction manual and consider it an integral part of the machine;
- The instruction manual must be readily accessible by the personnel assigned to operate it and to perform maintenance on it;
- This manual should be kept for the entire service life of the machine;
- Make sure that any received update is incorporated into the text;
- Pass on the manual to any other user or subsequent owner of the machine;
- Use the manual in such a way as not to damage it;
- Do not remove, tear out or rewrite parts of the manual for any reason;
- Store the manual in areas protected from moisture and heat;
- If the manual is lost or partially damaged and it is no longer possible to read its contents either partially/completely, it is advisable to request a new manual from the manufacturer.

Pay maximum attention to the following symbols and to their meanings. They serve to highlight particular information such as:

WARNING



With reference to additions or suggestions for the correct use of the machine.

ATTENTION



With reference to dangerous situations that may occur with the use of the machine and that may cause serious injury to persons or damage to property.

DANGER



With reference to dangerous situations that can occur when using the machine and which could cause severe injury or death if not avoided.

1.4 - INTRODUCTION

The service standards described in this manual are an integral part of the machine supply. These instructions are also addressed to operators already specifically trained to operate this kind of machinery and contain all the information necessary and essential for safe operation and for the correct/optimal use of the machine. Rushed and incomplete preparations lead to improvisation, which is the cause of many accidents.

Before starting work, carefully read and thoroughly follow the following suggestions:

- Become familiar confident with all permissible operations and operating positions before starting to operate the machine;
- The operator must always have the instruction manual available at all times;
- Plan each intervention carefully;
- Obtain all the information necessary for machine road transport, such as distance, itinerary, height of level crossings, height of bridges, etc.;
- Know in detail where and how the machine is expected to be used: ground capacity;
- Before starting work, ensure that the safety devices are working correctly and that there is no uncertainty regarding their operation; otherwise, do not use the machine under any circumstances whatsoever;
- Carefully read the warnings relating to special hazards contained in this manual;
- Constant and thorough preventive maintenance always guarantees high operational safety of the machine. Never put off necessary repairs and ensure they are performed exclusively by specialised personnel, using only original spare parts.

1.4.1 - UPDATING THE MANUAL

The information, descriptions and illustrations contained in this manual reflect the state of the art at the time the machine was marketed.

The manufacturer reserves the right to make changes to the machines at any time for technical or commercial reasons. In the event that such changes are made, the manufacturer has no obligation (for safety reasons) to modify the other machines sold up to that point or to send updates for the manual. Moreover, this publication shall not be considered inadequate. Any additions that the manufacturer deems appropriate to provide as a result of the changes made must be kept with the manual, and considered an integral part thereof.

1.4.2 - COPYRIGHT

The copyright of this manual belongs to the machine manufacturer. This manual contains technical texts, drawings and illustrations which cannot be disclosed or transferred to third parties, in whole or in part, without the written authorisation of the machine manufacturer.

1.5 - WARRANTIES

The parts supplied by McConnell are covered by a 12-month warranty, that becomes valid upon commissioning, proven by the documentation delivered to the customer. In any case, refer to the machine order confirmation or to any specific agreements entered into during the sale. McConnell shall repair or replace parts recognised as defective during the warranty period (see attached service log).

By replacing the defective part, McConnel shall consider itself free from any other expenses borne by the Dealer and the Dealer's Customer, for instance alleged damage, either present or future, such as lost earnings, conventional penalties, etc.

Ordinary and extraordinary maintenance must be performed in accordance with the instructions contained in this manual. For all cases not included and for every type of assistance, contact the company McConnel directly by registered letter or fax, even in the case of agreements made by telephone. The company McConnel shall not be held responsible for any delays or missed interventions.

McConnel shall not be held responsible for any damage or malfunctions due to technical operations carried out on the machine by unauthorised personnel.

1.6 - RESPONSIBILITIES

McConnel considers itself exempted from all liability and obligations for accidents involving personal injuries or damage to property which may occur due to:

- Failure to observe the instructions given in this manual to run, operate and perform maintenance on the machine;
- Abrupt actions or incorrect manoeuvres when operating or performing maintenance on the machine;
- modifications made to the machine without prior written authorisation from McConnel;
- Any other events that cannot be considered normal and correct use of the machine.

In any case, whenever the user blames the accident on a defect of the machine, it is necessary to prove that the consequent damage was a main and direct consequence of such defect.

Any tampering or the use of non-original spare parts will create the conditions for voiding the warranty and put the operator's safety at risk.

ATTENTION



- **For repairs or maintenance always make exclusive use of original spare parts.**
- **McConnel declines all liability for any damage that may be caused as a result of non-compliance with the above.**
- **The machine is guaranteed according to the contractual agreements entered into upon sale.**
- **The warranty, however, will not apply if the rules and instructions of use contained in this manual have not been complied with.**

1.7 - PERMITTED USES

The CUTTER BAR mowing bar is a piece of equipment built to be used by professional personnel, mainly for green maintenance and grass cutting work.

Every other use is not appropriate and the manufacturer declines any responsibility for any damage to persons, property or to the machine itself that might derive from such inappropriate use.

This machine is generally used during daylight hours. If, under exceptional circumstances, it has to be used at night or in conditions of reduced visibility, an auxiliary lighting system must be used.

Operate in daylight or with artificial lights which guarantee a visibility of at least 100 metres.

1.8 - IMPROPER OR PROHIBITED USES

ATTENTION



This paragraph indicates some of the improper or unauthorised uses; as it is impossible to foresee all possible improper uses, if there are particular occasions of use of the machine not contemplated among those permitted, consult McConnell before carrying out the work.

The following uses must always be strictly avoided:

- Use of the machine by minors, inexperienced, untrained or unlicensed persons;
- Use of the machine to lift and/or to transport persons or property;
- Use of the cutter bar as a pile driver;
- Use of the machine to tow damaged vehicles;
- It must not be used on surfaces contaminated by glass, loose stones, pieces of iron or other foreign bodies that may be thrown into the air by the blades or damage the cutter bar;
- Lifting or pulling tilted loads;
- Putting the machine into contact with accessories or equipment classified as dangerous due to their chemical or physical properties (e.g. materials which are flammable, toxic, explosive, etc.);
- Overloading the machine beyond its allowed limits;
- Use of the machine with tools not authorised by McConnell;
- Making changes to the machine (hydraulic, electrical or mechanical);

DANGER



Use of the machine without suitable protections can be dangerous both for the operator and for persons or animals within the operating range of the machine.

Range of action means the distance around the machine that should be free from animals and/or persons as a hazard may occur.

1.9 - RUNNING-IN AND TESTING OF THE MACHINE

Each machine is carefully adjusted and tested before delivery.

A new machine must however be used with caution for the first 100 hours for the purpose of the efficient running-in of the various components.

If the machine is subjected to an excessive work load during the initial phase of operation, its potential performance will be prematurely compromised and its functionality reduced in a short period of time.

During the running-in period, pay close attention to the following points:

- after starting, allow the engine to run at a low speed for 5-6 minutes.
- Avoid making the machine work to its limit for the first 100 hours of operation. Avoid sudden accelerations or decelerations.

1.10 - FOR YOUR SAFETY

- Do not remove the safety protections when the cutter bar and/or accessories are in motion
- During the work of the cutter bar, it is advisable to keep a safety distance of 50 meters and check that there are no persons and/or animals within the danger range of the machine. In such case, immediately stop the machine functions.
- During work the tools must never touch the ground.
- Before carrying out any work on the cutter bar, for example cleaning or maintenance operations, stop the hydraulic motor, wait for the complete stop of the cutter blades and turn off the thermal engine of the machine.
- Do not transport persons on the machine during transport or work.
- When the cutter blades are in motion, do not attempt to introduce or extract material with any tool, especially with your hands or feet.

ATTENTION

- **Stickers are applied to the machine to ensure safer use. It is therefore very important to replace them if they are no longer legible.**
 - **The operator must not be an occasional one, but must be experienced with this type of machine, and be trained.**
 - **If the direct view of the work area from the driving position is not sufficient, the operator must be assisted by an expressly appointed person.**
 - **The person assisting the activity must always stand to the side of the machine and NEVER in front or behind it in order to be protected and at a safe distance (greater than 50 meters).**
 - **Daily check the integrity and functionality of the parts subject to wear resulting from use: (pins, valves, piping etc.). Where necessary, replace parts with original parts.**
 - **Never, under any circumstances, tamper with the hydraulic system and in any case do not remove the seal from the valves as this would invalidate the warranty. For valve adjustments, contact an authorised McConnel workshop.**
-

2 - MACHINE SPECIFICATIONS

2.1 - MACHINE DESCRIPTION

Lightweight and handy cutter bar ideal for cutting grass or fodder at the base and then allowing drying and subsequent storage.

Use of the same for processes other than those provided for, and not in accordance with what is described in this manual, exempts McConnell from any direct and/or indirect responsibility.

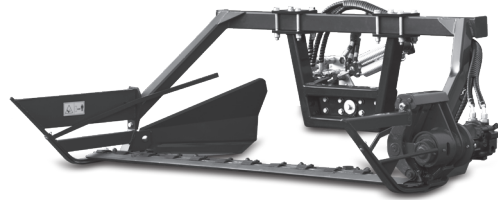

2.2 - RULES APPLIED

The equipment was designed and built in compliance with the EC directives on safety and with the approximation of the laws of the member States, specifically with the Machinery Directive 2006/42/EC to the extent applicable.

The following standards were also taken into account in the design:

- UNI EN ISO 12100:2010 "machinery safety";

The following technical specifications were used to update the equipment:

- ISO 3767-1:2016;
- ISO 11684:1995.
- ISO 3864-3:2012

2.3 - IDENTIFICATION OF THE EQUIPMENT

The identification plate (A) of the equipment is fixed to the side on the back of the frame. the serial number (B) and operating hours must always be indicated in the service requests and in the spare parts orders.

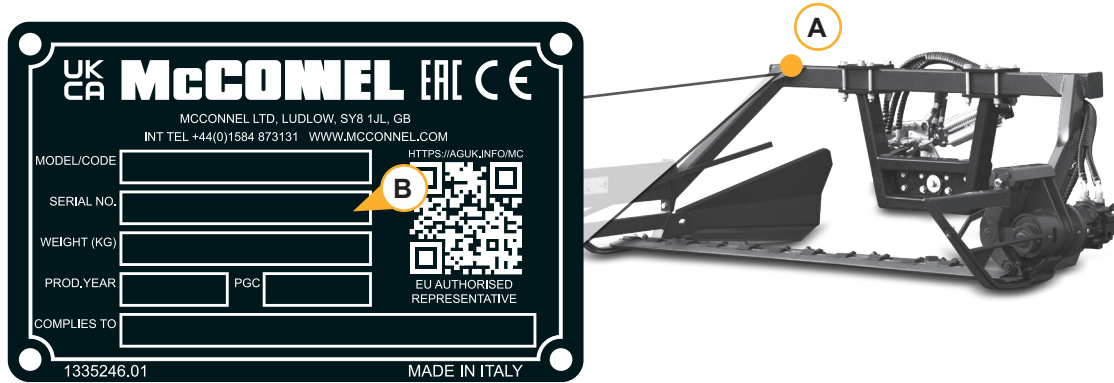

WARNING



The serial number and year of manufacture must always be indicated in assistance requests and spare parts orders.

2.3.1 - DEFINITION OF THE DIRECTIONS OF THE EQUIPMENT

Left or right means with respect to the forward direction of movement.

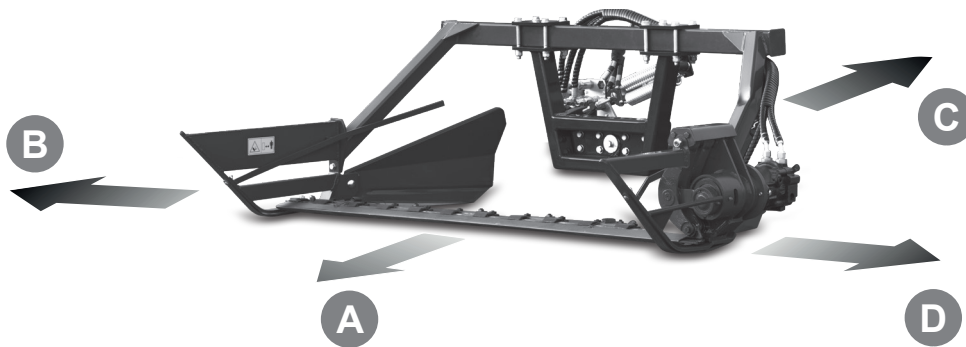

- A Forward (work direction)
- B Left side
- C Back
- D Right side

2.4 - NOISE LEVEL

For the sound levels, refer to the use and maintenance manual of the machine on which this equipment is connected.

3 - SAFETY REQUIREMENTS

3.1 - GENERAL SAFETY RULES

3.1.1 - GETTING TO KNOW THE MACHINE THOROUGHLY

The machine must be used only by qualified personnel, who must be familiar with the location and the function of all its controls, tools, indicators, indicator lights and plates.

3.1.2 - WEAR PROTECTIVE CLOTHING

Wear tight fitting clothing and use personal protective equipment in accordance with current regulations. In particular, they are required to wear:

- Noise protection headphones;
- Safety footwear;
- Overalls;
- Work gloves.



During use, the machine may produce dust emissions. If working with dry products (straw or stretches of bare earth) it is advisable to use protective devices such as:

- Eye protection goggles;
- Respiratory dust masks.

3.1.3 - WARNINGS FOR CHECKS AND MAINTENANCE

When the machine is under maintenance:

- Remove the ignition key from the machine before carrying out any maintenance or verification operations;
- Clearly display a sign on the machine which reads, "DO NOT START THE ENGINE".
- Delimit the area with road cones;
- When performing maintenance, be sure to first check which operations are to be performed;
- In the event of extraordinary maintenance involving lifting the machine or parts of it, the machine must be taken to a workshop which is suitably equipped with appropriate lifting devices;
- In the case of ordinary maintenance, simply place the cutter bar on flat ground and be sure to block the machine itself.

3.1.4 - CHECKING THE MACHINE

- Carefully check the machine every day before use, checking the integrity and functionality of the parts affected by wear and tear deriving from use: (pins, valves, piping etc.). Where necessary, replace parts with original parts.
- Start the thermal engine only in well ventilated areas and make sure that there are no persons within the operating range of the machine.
- Covers and safety elements must not be removed. They are designed and built for your safety.
- Do not use the machine if the protective devices or covers are damaged or missing.
- After cleaning or repair the protective devices must be reapplied immediately.
- Always keep the machine and its accessories clean and in a good general condition, always removing the shredded and deposited material on the machine.

ATTENTION



- **It is strictly forbidden to make changes to the machine without prior authorisation from the manufacturer.**
- **Changes to the machine can in fact cause hazards and injuries.**
- **If these instructions are not observed, the manufacturer assumes no responsibility for the machine.**

Range of action means the distance around the machine that should be free from animals and/or persons as a hazard may occur.

3.2 - GENERAL PRECAUTIONS

- The operator must never be an occasional worker but must have some experience with this type of machine.
- 'Operator' refers to a person trained to work with these types of machines and/or equipment
- It is mandatory to read and follow the instructions given in the use and maintenance manual before performing any operation or manoeuvre with the machine. It is too late to do so while working. Improper use or an incorrect manoeuvre can result in serious damage to people or property;
- The operators and maintenance technicians must be familiar with the machine, in particular they must know the dangers deriving from incorrect use or incorrect repairs;
- If the direct view of the work area from the driving position is not sufficient, the operator must be assisted by an expressly appointed person.
- Before starting the machine, carry out all checks on the self-propelled vehicle and tool concerning:
 1. Operation;
 2. Road safety;
 3. Accident prevention regulations;
 4. Safety precautions.
- Even when using the machine correctly, stones or other objects can be projected far away. **Therefore, no-one must be in the range of danger equivalent to 50 meters.** Pay close attention when working near roads or buildings;
- Before starting the work, always check the integrity of the tools and of all guards; if damaged or missing, replace them;
- Make sure that nobody can involuntarily start the machine during checks and repairs.

- Do not wear loose clothing;
- Never lift persons or objects using the cutter bar;
- Never work, walk or stand under the cutter bar;
- Never transport persons on the cutter bar;
- Never stand near the tool until it is completely still or stopped;
- Before each operation, check that there are no people and/or animals within the machine's range of operation;
- Before leaving the machine, proceed as follows:
 - Inhibit every function;
 - Brake the machine and in the case of steep slopes insert the wheel stop wedges;
 - Turn the heat engine off and remove the ignition key.
- Immediately replace any lost or worn safety warning plates or pictograms;
- Never underestimate or ignore safety regulations;
- If the safety devices are not working, replace them immediately.

3.2.1 - SAFETY WARNINGS

The machine has been designed and built according to the technical requirements in force for operations such as mowing grass, hedges, maintenance of green areas of roadsides, slopes, canals, water drainage, etc. Observe the laws, provisions, requirements, ordinances and directives in force for such machines.

The materials used and the equipment parts, as well as the production procedures, quality guarantee and checks meet the highest safety and reliability standards.

Use the machine for the purposes specified in this manual of use, manoeuvre it with the due diligence and carry out accurate maintenance and revisions as envisaged to obtain the highest performance, continuous operation and ensure a long lifespan of the machine.

When circulating on public land, respect all the provisions on road traffic circulation in force in the country of use of the machine.

3.2.2 - SAFETY REQUIREMENTS FOR ROAD TRAFFIC CIRCULATION

The manufacturer shall not be held responsible for any accidents, while using the machine, if the user were not to comply with laws, requirements, regulations and the rules in force for machines used for mowing grass, shrubs, maintenance of green areas of roads, embankments, canals, water drainage, etc.

The machine is designed to work in normal weather conditions at a temperature ranging from -10 C° to +40 C°, however, it should operate only under such environmental conditions.

Regarding mowing on public roads, refer to the instructions given by the work supervisor as this is a mobile site.

- During road transfers, moderate the speed, above all on bumpy roads;
- During the transit on public roads, respect the applicable regulations;
- Never transport the machine with the tool in operation, even for short distances.

3.2.3 - OPERATIONAL SAFETY

The manufacturer shall not be held responsible in case of malfunction and damage if the machine:

- is used for purposes other than those for which it was intended;
- is not manoeuvred, started and maintained according to the service instructions specified in the following manual;
- does not periodically and constantly undergo maintenance as prescribed or non-original spare parts are used;
- is modified or replaced without written authorisation from the manufacturer, especially when the effectiveness of the safety systems has been intentionally reduced or eliminated;
- is used outside the authorised temperature range and the purposes for which it was designed;

The machine user is responsible for all property damage or personal injuries caused by the machine's operation.

3.2.4 - SAFETY RULES WHEN USING THE MACHINE

- When working, be very careful not to come into contact with resistant objects, such as manholes, wells, pavements, guardrails, railway lines, stony ground, etc. This could cause the tools to break, and they could be dangerously projected at very high speed.
- Should iron wires, ropes, chains or other elements twist around the cutter blades, stop immediately in order to avoid causing damage or dangerous situations; stop the machine, switch off the engine and remove the key. After putting on work gloves, restore the cutter blades with the help of pliers or shears.
- Do not continue to use the cutter bar in the presence of vibrations that could cause breakage and serious damage. Ascertain the cause of the problem and eliminate it.
- It is forbidden to intervene for maintenance, cleaning, adjustments or similar actions with the machine in motion, on any part of it or on the interchangeable equipment connected to it. Any activity of maintenance, cleaning or adjustment must be carried out strictly with the engine off.
- During operation, pay attention to the electrical cables, especially if you need to pass under them, as you could lose the radio signal. In these cases the machine immediately switches off the engine and stops.
- Before lifting/lowering the equipment with the lifting device, make sure that there are no persons within 50 metres of the machine.

DANGER



- **Do not attempt to release the cutter blades by turning them in the opposite direction.**
- **Danger of projection of materials.**

If a danger is perceived, it is necessary to operate with the emergency mushroom button on the machine and/or on the radio remote control.

The two mushroom buttons, however, do not have the same function: the one on the radio remote control is used to interrupt all the functions of the machine while keeping the thermal engine on; instead the one on the machine, in addition to interrupting all the functions of the machine, also turns off the thermal engine.

DANGER



If there is a danger that requires the entire machine to be turned off, operate with the mushroom on the radio remote control and turn off the engine otherwise operate directly on the emergency mushroom on the machine.

3.2.5 - HYDRAULIC SYSTEM SAFETY REQUIREMENTS

- Stop immediately if you notice oil leaks.
- Periodically check the hoses. If they are worn, contact McConnel.
- Before working on the hydraulic system, place the cutter bar on the ground and turn off the engine.
- Oils and greases must be disposed of according to anti-pollution standards.
- Do not tamper with the hydraulic system for any reason and in any case do not remove the seal on the valves, as this would invalidate any form of warranty. To adjust the valves, contact an authorised workshop.
- Excessive heating of the oil causes damage to the gaskets of the hydraulic circuit and deterioration of the fluid itself. Heating is caused by lamination of the oil through the maximum pressure valve. For this reason, avoid extended operation with the jacks at the end of the stroke.

WARNING



- **Never search for oil leaks with bare hands or other body parts; use paper or cloths to locate the leak.**
- **Always wear waterproof gloves and goggles.**
- **Wait until the oil has cooled before intervening.**
- **Discharge the oil pressure before disconnecting the hoses or when performing maintenance on the system.**
- **High pressure oil may penetrate the skin and cause serious infections; in such case seek medical attention immediately.**
- **These operations must be carried out by authorised and adequately trained personnel.**

ATTENTION



Replace the hydraulic hoses whenever they are damaged and in any case always no later than 6 years.

3.2.6 - LOCATION OF THE SAFETY PLATES

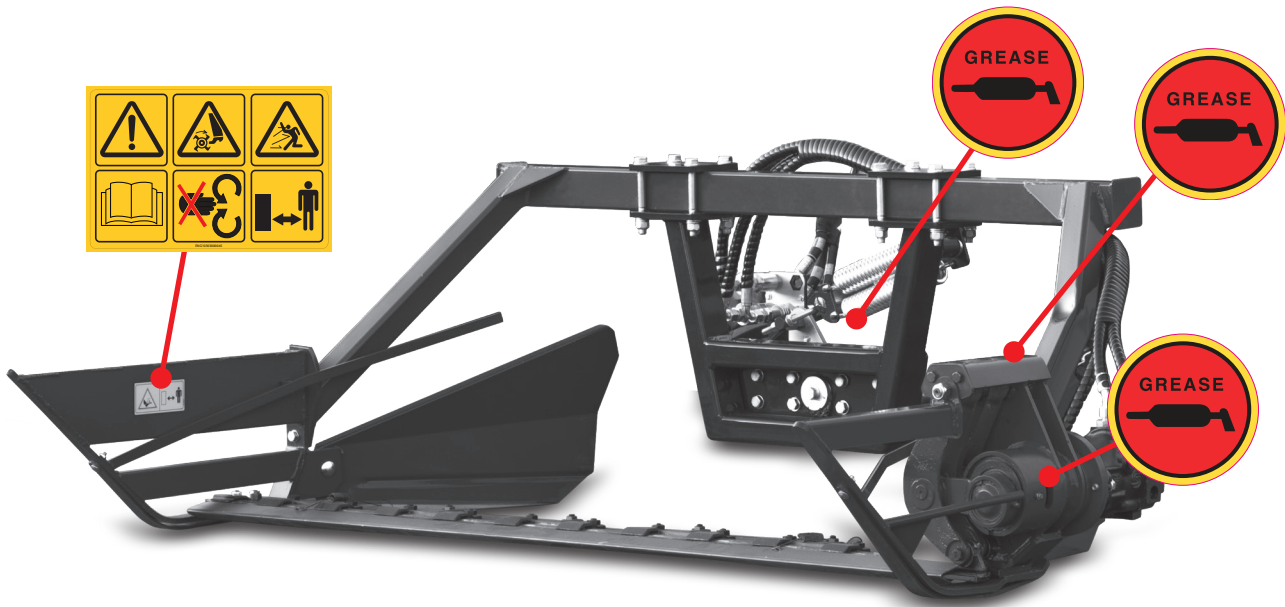

3.2.7 - DESCRIPTION OF THE SAFETY SIGNS

WARNING



Ensure the good condition of the safety pictograms. If the plates are damaged, they must be replaced with original plates that can be requested from McConnell and placed in the position indicated in the manual. Make sure that the safety pictograms are legible. Clean them using a damp cloth with soap and water.

Warning signal

Read the documentation annexed to the machine before using it

Warning signal - Tools rotating

Danger of injury to the lower or upper limbs. Ensure when performing maintenance on the machine that the cutter blades are stopped and in the operating phase keep a safe distance.



Danger sign - Flying objects

Indicates the possibility of stones or other bodies coming out and being project, therefore requiring operation at a safe distance from the machine.

Greasing point sticker

Identifies the greasing points of the machine. Indicates greasing as prescribed in the following manual.



3.3 - SAFETY PRECAUTIONS FOR MAINTENANCE

3.3.1 - CARE AND MAINTENANCE

The cause of much damage and many accidents can be attributed to mistakes or insufficient maintenance, such as:

1. Insufficient oil, grease;
 2. Insufficient cleaning;
 3. Failure in the hydraulic system (damaged hoses, loose screws, etc.);
 4. Inaccurate maintenance or alterations of the systems without permission.
 5. Work on stony soils or where there is material that can be projected at high speed.
- Please note that all maintenance operations must be carried out by qualified and trained personnel, with the machine stopped.
 - Maintenance and repairs must not be done outside but in a suitably equipped workshop.
 - During the phases of use, adjustment, maintenance, repair or handling, the operator must use appropriate Personal Protective Equipment (PPE).
 - Used oil must be properly recovered and must not be disposed of in the environment since, according to current legislation, it is classified as hazardous waste and, as such, must be taken to an appropriate waste collection centre. Contact the closest body approved to handle used oil.

Before starting any maintenance, the following operations must be carried out:

- During maintenance, the machine must be placed on flat, compact ground.
- Turn off the machine motor, remove the ignition key.
- Set up all the forms of accident prevention envisaged for the type of operation in progress.
- If compressed air is used to clean the machine, it is necessary to protect yourself with appropriate glasses and dust mask.
- Do not perform any repairs with which you are not familiar. Always follow the instructions and, in the absence of these, contact the supplier or an expert.
- Before any maintenance operation, make sure that the parts which can get hot are cold.
- Attention: replace the hydraulic hoses whenever they are damaged and, in any case, always within and no later than every 6 years.
- Only use the prescribed lifting points.
- Make sure that the lifting equipment selected is suitable for the operations to be carried out and complies with safety regulations.
- Before carrying out operations under suspended parts or with the machine raised from the ground, secure the machine with supports or trestles adequately sized, taking into account the weight of the part supported.
- Do not keep the tractor engine running in a closed space unless there is ventilation system capable of disposing of the harmful exhaust gases which are concentrated in the air.
- Avoid prolonged and repeated skin contact with fuels, lubricants, fluids as they can lead to skin disorders and other disturbances.
- Do not ingest any fuel, lubricant or fluid. In the event of accidental contact with the eyes, wash the part affected with plenty of water.
- Do not perform any welding in a closed or inadequately ventilated space.
- Do not perform any welding on painted surfaces, or near painted surfaces, in order to avoid toxic vapours from being generated.

- Remove paint with suitable products then wash the surfaces and leave them to dry.
- Discharge the pressure from circuits before carrying out any intervention.
- Do not use your hands to locate leaks of pressurised fluids.
- Leaks of fluids under pressure can penetrate the skin and the eyes with extremely serious consequences.
- The interventions described in the following points do not require any specialisation. The operator must be aware of and follow the instructions precisely and must have put the machine out of service.
- Periodic checks and maintenance operations must be carried out at the times and in the manner established and are the operator's responsibility.
- Failing to observe the standards and timing for maintenance threatens the proper operation of the machine and its lifespan and consequently invalidates the warranty.
- Intensify the frequency of maintenance in severe operating conditions (frequent stops and starts, prolonged winter season, etc.).
- Never leave the operating position of the machine with the machine switched on.
- **ATTENTION:** Due to vibrations, regularly check that all screw connections are firmly tightened. This check should be performed for the first time after 8 hours of operation. Check the fastening of the cutter blades and that the screws are correctly tightened.
- If for any reason the cutter blades start to vibrate, immediately stop the machine and restore balance, McConnell declines all responsibility relating to persons or property caused by an operator's negligence.
- Clean the machine after use. Do not use petrol or solvent-based products to clean the machine. Do not clean electrical parts with water under pressure.
- During operation, and in particular in windy conditions, the user must carefully choose his position in order not to be exposed to exhaust gases, dust or mown grass.
- Do not operate the equipment if you are unable to see it (behind ridges, round corners of buildings, in tall grass etc...).

3.3.2 - WARNING PLATES

Before performing any maintenance operation, place the machine on solid and level ground, lay the equipment on the ground and stop the engine. If other people start the engine and use the control levers while maintenance is being performed, there is a risk of serious injuries or death. To avoid these dangers, before carrying out the maintenance, put the remote control in a safe position, remove its battery and hang the warning signs on the machine.



3.3.3 - TOOLS

Only use tools specified by the manufacturer; in order to avoid injury, discard worn or damaged, poor quality or improvised tools.

3.3.4 - PERSONNEL

The routine maintenance indicated in the manual must be carried out exclusively by authorised and trained personnel. To perform maintenance on or service components not specified in this manual, please contact McConnell.

3.3.5 - KEEPING THE MACHINE CLEAN

Cleaning of the cutter bar is an integral part of the machine's routine maintenance and is an essential activity in order to check the state of the machine itself.

3.3.6 - PERIODIC REPLACEMENT OF ESSENTIAL SAFETY COMPONENTS

Periodically check the following components:

- Blade protection. If deteriorated, it must be replaced immediately otherwise the machine's safety could be compromised.
- Blades: if they have cracks, breaks or excessive wear, they must be replaced.
- Carefully check the efficiency and cleanliness of the quick coupling devices supplied with the machine.
- Even if they appear to be in good condition, these components have to be replaced periodically with new pieces. These components tend to deteriorate over time.
- In the event that one of these parts is faulty, replace or repair it even if it is still not past its expiry date.

4 - TECHNICAL DATA

4.1 - DIMENSIONS AND WEIGHTS

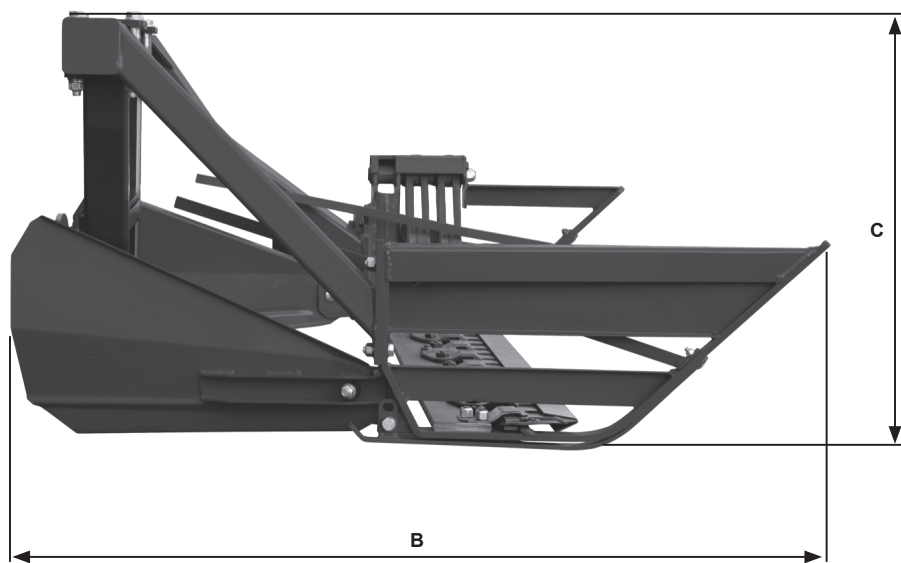
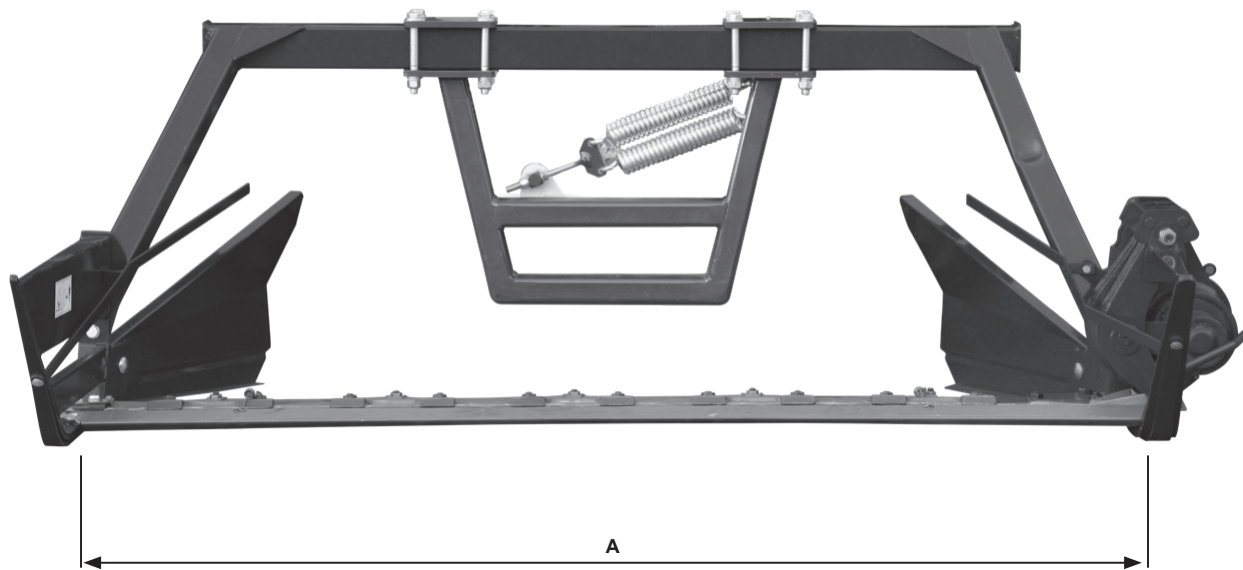

WORKING WIDTH)	A	1820 mm
DEPTH (max)	B	1660 mm
HEIGHT (max)	C	700 mm
WEIGHT		218 kg

4.2 - TECHNICAL SPECIFICATIONS

PRESSURE	bar	130
POWER	kW	15
SECTIONS	No.	23
TEETH	No.	24
OSCILLATION		13° right - left
HYDRAULIC MOTOR	cc	35

5 - TERMINOLOGY

5.1 - DEFINITION OF THE TERMS USED

OPERATOR

Personnel assigned to manoeuvring the machine in working and moving conditions and to normal control and cleaning operations on the machine.

Must not have disabilities of any kind or health problems.

SPECIALISED OR MAINTENANCE PERSONNEL

Personnel responsible for carrying out routine maintenance, assembly, disassembly and reassembly of some machine components.

Must not have disabilities of any kind or health problems.

AUTHORISED PERSONNEL

Personnel trained to carry out extraordinary maintenance operations, assembly, disassembly and reassembly of machine components.

Must be authorised in writing by the company McConnell to intervene on the machine.

Must not have disabilities of any kind or health problems.

OPERATOR ASSISTANT

Personnel assigned to assist the operator in some machine manoeuvres (manoeuvres on site with reduced visibility, loading and unloading from means of transport, manual pump operation, etc.), assisting with the activities in the mobile site (mowing on public road).

Must know the main work safety requirements.

AUTHORISED WORKSHOP

Workshop consisting of personnel assigned to performing operations of extraordinary maintenance, assembly, disassembly and reassembly of particular components of the machine.

Must be authorised in writing by the company McConnell to intervene on the machine.

The operator is invited to refer to the Standard EN 12100-2010 for the definition of the other terms used.

6 - USE OF THE MACHINE

6.1 - PRELIMINARY CHECKS

The operator must verify that the equipment is accompanied by a use and maintenance manual; In case of resale as "second-hand machine" the customer/user must provide the buyer with the manual use and maintenance manual intact in all its parts, as well as the checks booklet and the registration certificate (if required).
The machine is equipped with two copies of keys (starter, cab, hoods, etc.).
A copy must be delivered to the operator and one must be kept in a safe place by the site manager (not inside the machine!) to help the operator in case of any illnesses.

6.2 - CHECKS TO BE PERFORMED AT THE START OF EACH WORKING DAY

Carry out an external inspection of the machine (joints, hoses, hydraulic components, etc.) and check for any leaks of oil or other liquids.

Check the rubber hoses of the machine and make sure there are no cuts, holes, scratches, leakages, etc.

Check that the safety guards are correctly positioned and intact. If they are damaged, replace them. If they are incorrectly positioned, arrange them appropriately.

WARNING



Never search for oil leaks with bare hands or other body parts; use paper or cloths to locate the leak. Always wear waterproof gloves and eye protection.



6.3 - ATTACHING THE EQUIPMENT

DANGER



- When coupling or uncoupling equipment, stand at the side of the machine away from the equipment (at least one metre away).
- Before connecting the quick fit attachments, the equipment must be connected to the machine mechanically.
- The hydraulic connections must be carried out when the heat engine is switched off.

ATTENTION



- Before making a hydraulic connection between machine and equipment, clean the quick couplings of both parts with a cloth; this prevents the hydraulic oil becoming contaminated with foreign matter.
- Firmly tighten the screw-on hydraulic couplings after hitching the equipment.
- Failure to tighten the quick couplings (even partially) can cause the hydraulic motor of the tool to break and / or the oil seal to be ejected.

ATTENTION



- Read and follow the instructions provided to ensure safety during the use of the equipment moved by the PTO.
- Comply with the indications provided by the equipment manufacturer.
- Use the safety devices prescribed and make sure that they are in good condition.
- Make sure that the equipment is correctly connected and that it does not hit other parts of the machine when raised.

ATTENTION



In some cases, the tool change causes the overall centre of gravity to shift which could make the machine unstable. Contact McConnell about adding ballast to correct the machine's centre of gravity.

The machine is fitted with a lifting device on which the various approved tools can be attached. To do this, follow the steps below:

1. Start the diesel engine, connecting it with the radio remote control;
2. Lower the lifting device as far as possible using the right-hand joystick (**B**);

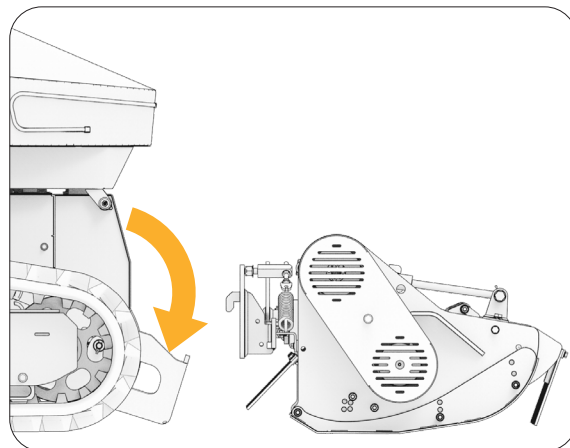

- Approach slowly with the machine near the tool plate, previously placed in front of the machine;

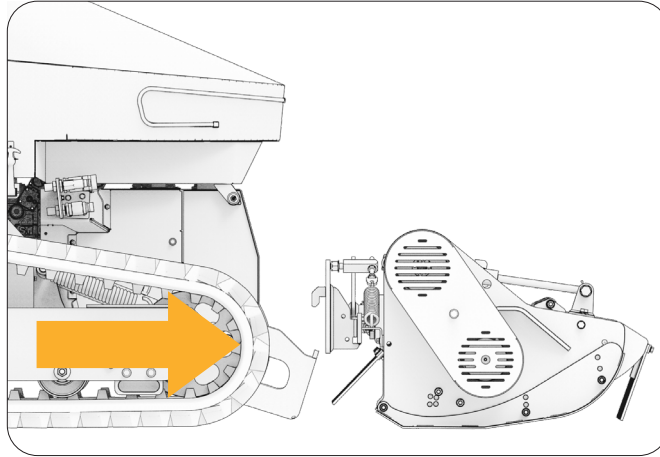

- Using the right-hand joystick (**B**), raise the lifting device to attach the equipment;
- Fasten the tool to the support on the machine using six M12 x 40 screws using an 18 mm wrench;
- Turn off the engine;

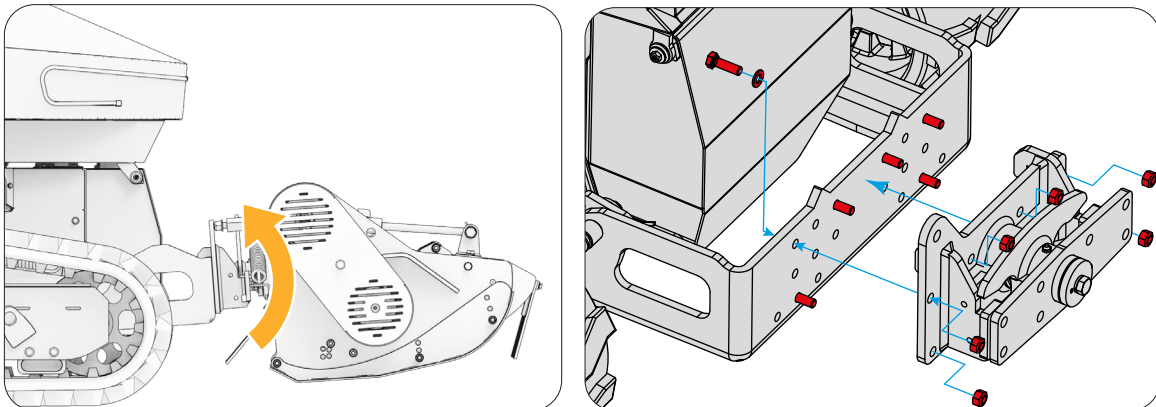

- Connect the hydraulic power lines of the tool to the quick couplings on the right-hand side of the machine; taking care to clean them before making the connection. The outermost coupling is for the drainage line, while the inner two are for lines (**A**) and (**B**).

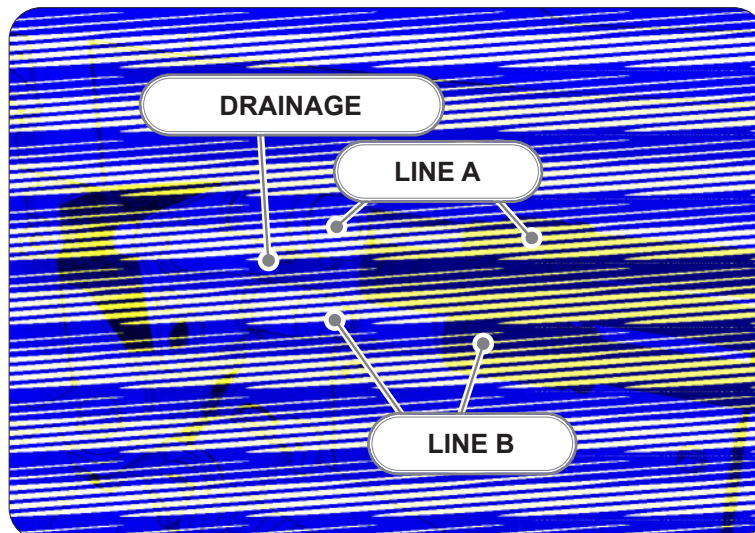

ATTENTION

- If the tool is disconnected from the machine and left without an expansion tank (H), the hydraulic motor gasket may break.
- McConnell is not responsible for any damage or malfunction due to non-compliance with this warning.
- Connect the expansion tank to the female coupling of the drain to the tool.



6.4 - TRANSMITTER UNIT

6.4.1 - OPERATING THE TOOL

The tool's hydraulic motor is enabled by the switch (5) and controlled by the potentiometer (11). Follow the instructions below to start it.

- Then, enable and select the rotation of the tool's hydraulic motor using the switch (5). To move the tool, gradually turn the potentiometer (11) clockwise. When the tool starts to move, increase the hydraulic engine rpm by turning the potentiometer to 100%.
- Now, you can increase the rpm of the heat engine until you reach the maximum working speed by pressing the button (14A).



6.4.2 - STOPPING THE TOOL

To stop the tool, proceed as follows:

- Decrease the heat engine rpm by pressing the button (14B) until you reach the minimum speed.
- Turn the potentiometer anti-clockwise (11) to the minimum setting. The tool's hydraulic motor then stops.
- Disable the hydraulic motor by putting the switch (5) in the central position.



6.4.3 - LIFTING DEVICE

The lifting device is controlled by the right-hand proportional joystick (B).

- Moving the joystick (B1) forward lowers the lifting device.
- The lifting device is raised by moving the joystick (B2) backwards.



WARNING



FLOATING FUNCTION

Lower the lifting device so that the tool is resting on the ground. Extend the cylinder rod of the lifting device until the pin reaches the centre of the slot. In this way, the tool will follow the contour of the ground more accurately.

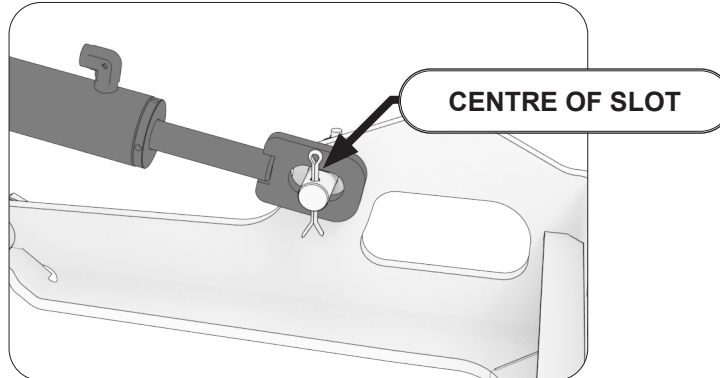

ATTENTION



- It is recommended not to adjust the lifting device when the equipment is in operation to prevent cutting residues from being thrown long distances.
- It is recommended not to adjust the lifting device if you are on a slope with the front of the machine facing uphill.

6.5 - MOWING

WARNING

- **During the first mowing, reduce the forward speed.**
- **When running idle with the machine reduce the number of revolutions of the equipment;**
- **Mow alternately, resuming mowing, always entering close to an exit;**
- **In the case of lodged fodder, mow in the opposite direction;**

To start mowing work, it is necessary to:

- Place the cutter bar on the ground;
- Activate the cutter bar;
- Increase the number of turns of the cutter bar.

6.6 - PROBLEMS, CAUSES AND SOLUTIONS

Malfunction	Cause	Solution
Problem of oil leaking from the pipes.	Problem of inadequately tightened fittings or damage to a pipe.	Tightening of the fittings, replacing of the fitting if necessary; replacing of the pipe if necessary.
Whistling coming from the belt transmission area.	Insufficient belt tension.	Check the tension of the belt.
The machine won't move.	The drive belt is worn, loose or broken.	Contact an authorised dealer.
	The drive belt has descended from the pulley.	Contact an authorised dealer.
	Transmission not working.	Contact an authorised dealer.
Abnormal vibrations.	The mowing blade is curved or unbalanced.	Fit a new mowing blade (or blades).
	The blade assembly bolt has become loose.	Tighten the blade assembly bolt.
	The motor assembly bolts have become loose.	Tighten the motor assembly bolts.
	The motor pulley, idler pulley or blade pulley have become loose.	Tighten the pulley concerned.
	The motor pulley is damaged.	Contact an authorised dealer.

NOTE: If the fault or the cause of the fault is not indicated in the tables below, contact McConnel for the necessary repair.

7 - TRANSPORTATION AND HANDLING

7.1 - LIFTING

Pay attention to safety during the loading and unloading, which should be performed by qualified personnel (slingers, forklift, etc.).

When lifting the equipment, it is necessary to use the appropriate lifting points indicated by the pictograms and to make sure that ropes or chains suitable for lifting it are available.

To transport the equipment, an appropriately sized vehicle, with appropriate power, must be used, once suitably prepared.

The cutter bar must be placed flat and must be secured by anchoring ropes verifying its stability once positioned.

It should be noted that using ropes, slings or chains for lifting the equipment, it is necessary to comply with the diagram below, indicating the minimum pulling angles.

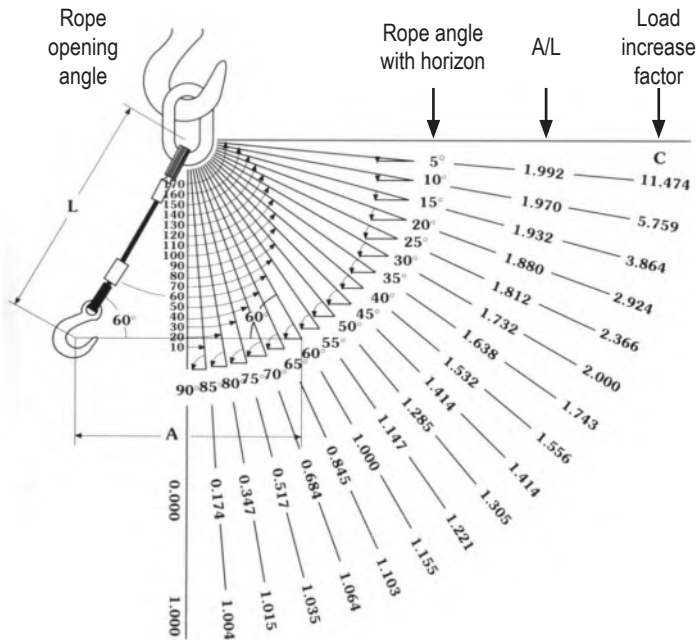

Apex angle	Load increase factor
0°	1
10°	1,004
20°	1,015
30°	1,035
40°	1,064
50°	1,103
60°	1,155
70°	1,221
80°	1,305
90°	1,414
100°	1,556
110°	1,743
120°	2,000
130°	2,336
140°	2,924
150°	3,864
160°	5,759
170°	11,474

8 - STORAGE

If the equipment is stopped for long periods, it must be stored in a place protected from the elements to prevent damage. Before storage, it is advisable to thoroughly clean all the equipment and to lubricate all the mechanical parts properly to protect them from rust. Check that the storage temperature is between 0°C and 40°C.

Before putting the equipment away for any length of time, the following steps should be taken:

- Thoroughly clean the equipment;
- Carry out a general visual inspection of the equipment to identify any structural damage or deep scratches on the paintwork, and ensure that the original safety signs are still in good condition, legible and in their original positions;
- Check for damage to the front and rear protections and to their connection devices;
- Grease all mechanical parts subject to friction, the tightening pins and all parts of the equipment not covered by the original layer of paint, thus avoiding the formation of rust;
- Connect the expansion tank (A) supplied with the tool to the drain pipe.
- If possible, store the equipment in a covered area, on a hard, flat surface, checking the correct positioning and, therefore, the stability of the equipment once placed on the ground.



WARNING



- **If the tool is disconnected without an expansion tank, the hydraulic motor gasket may break.**
- **McConnel is not responsible for any damage or malfunction due to non-compliance with this warning.**

8.1 - FIRST USE OR RE-COMMISSIONING AFTER A LENGTHY PERIOD OF INACTIVITY

Before using the equipment for the first time, or after a long period of inactivity, proceed as follows:

- Check that the equipment is not damaged;
- Check the mechanical parts, which must be in a good condition and not rusty;
- Check the state of wear of the tools;
- Carefully grease all moving parts;
- Check that there are no oil leaks coming from fittings or pipes;
- Check that all the protections are correctly positioned.

8.2 - DISMANTLING, DECOMMISSIONING

- If it is decided to no longer to use the equipment, or any part of it, it must be dismantled and decommissioned.
- Before proceeding with scrapping, it is necessary to separate the plastic or rubber parts, the electrical and electronic material.
- Collect any waste oil and dispose of it at the appropriate collection centres.
- Carry out these operations according to the regulations in force.

ATTENTION



If the equipment, or part of it, has been put out of service, its parts that are likely to cause any danger must be made harmless.

ATTENTION



It should be remembered that for any replacement of oils, rubber pipes and any part of the equipment subject to separate disposal, it is always necessary to refer to the current legal provisions on the subject. For the collection of waste oil it is necessary to contact the Italian "Obligatory Consortium of Used Oils" organisation.

9.3 - EXTRAORDINARY INTERVENTIONS

These are repairs or replacements of one or more components of the machine, which usually become necessary after a few years of efficient operation and which do not alter the characteristics of the machine. In the event of significant changes, the manufacturer cannot be held responsible for any resulting hazards. These interventions must be performed by authorised personnel.

9.4 - TABLES FOR THE CHOICE OF FLUIDS

9.4.1 - GREASES TABLE

COMPONENT	RECOMMENDED LUBRICANT	Specification INTERNATIONAL
HYDRAULIC SYSTEM Mineral Oil	ISO 46; Q8 HELLER 46	DIN 51 524, 2-HLP DIN 51 524, 3-HLP API CD, CE, CF
HYDRAULIC SYSTEM Biodegradable Oil	PANOLIN BIO HLP SYNTH E	FZG Test A/8.3/90 stage 12 ISO 15380 HEES
	Q8 HOLBEIN HP SE Bio 46	ISO 11158 Category HV Din 51524, Part 3 Category HVLP ISO 15380 / CEC-L33-A-93 - Water Hazard Class (VwVwS) WGK 1 - Category HEES
PINS, BUSHINGS AND FIFTH WHEELS	MOLY GREASE EP NLGI2 or NLGI3EP GREASE	Black greased with lithium soap with molybdenum disulphide. For automatic greasing the use of added CONTACT GREASE NLGI2 with purple lithium soap is recommended.
BEARINGS	PAKELO GREENPLEX EP NLGI 2 GREASE	EP ADHESIVE Grease, Aluminium complex soap

9.5 - DAILY MAINTENANCE

At the start of each working day, systematically carry out the following operations:

- Check and, if necessary, tighten loose screws and nuts.
- Check the efficiency of the accident prevention protections with possible replacement in case of damage or wear.
- Check the integrity of the hydraulic pipes and in the event of damage or wear, replace them.

9.5.1 - CLEANING THE EQUIPMENT

Clean the equipment at the end of the working day using pressurised water; removing shredding residues, earth, dust, etc., in particular residues of flammable material.

9.6 - BLADE MAINTENANCE

9.6.1 - CHECKING THE BLADES

WARNING

The blades must be checked *daily* or *every 8 hours*.

9.6.2 - BLADE REPLACEMENT

Replace the mowing blade as follows: loosen the screw (**A**) and the nut (**B**), remove the blade (**C**) to the right. Ensure that the bushing (**D**) does not come out of its seat. To reassemble the blade proceed in reverse.

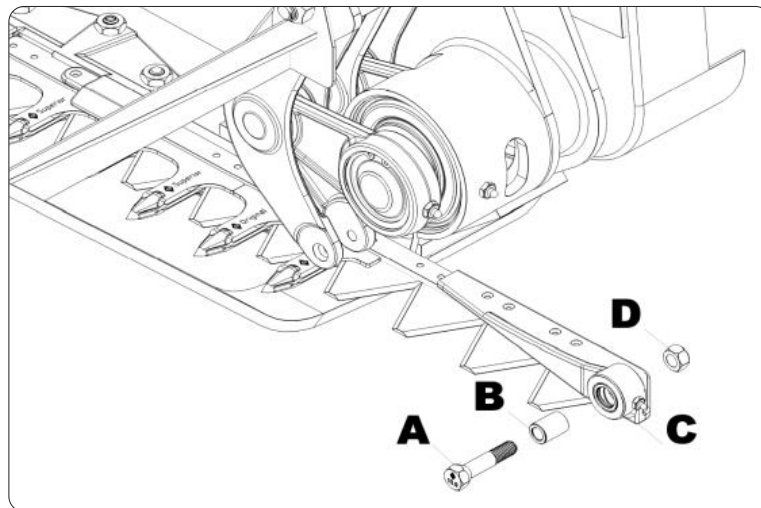

Position the tooth blade at the end of the stroke towards the outside and then proceed as for the section blade.

9.7 - BLADE HOLDER MAINTENANCE

WARNING



The blade holder check must be performed *daily* or *every 8 hours*.

9.7.1 - BLADE HOLDER ADJUSTMENT

It is possible that over time it will be necessary to adjust the blade holders. This is performed as follows:

- Loosen the two M12 nuts with a 22 wrench.
- Adjust the dedicated screw M10, leaving a clearance of $0.3\div 0.5$ mm between the blade holder and the tooth.
- Tighten the two M12 nuts and check the clearance with the feeler gauge.

However, we recommend that you have these operations carried out at authorised retailers.

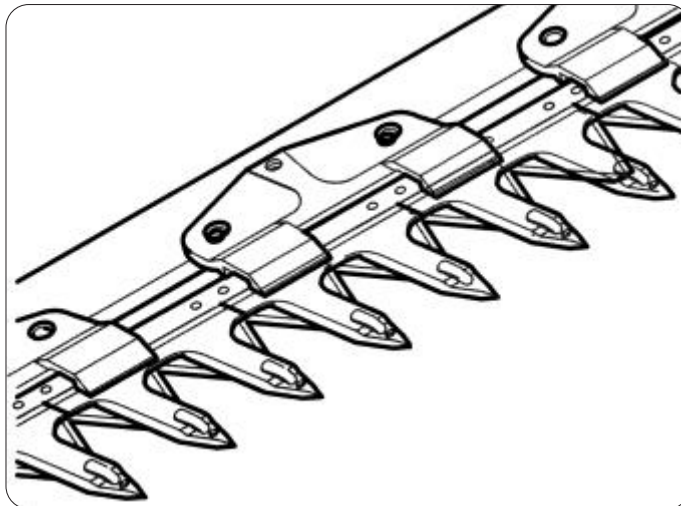

However, we recommend that you have these operations carried out at authorised retailers.

9.8 - GREASING OF PARTS

WARNING

Greasing of the connecting rod unit must be carried out *daily* or *every 8 hours*.

The cutter bar is delivered greased.
Lubricate all parts equipped with grease nipples, in particular the central connecting rods (A).

9.8.1 - CONNECTING ROD UNIT

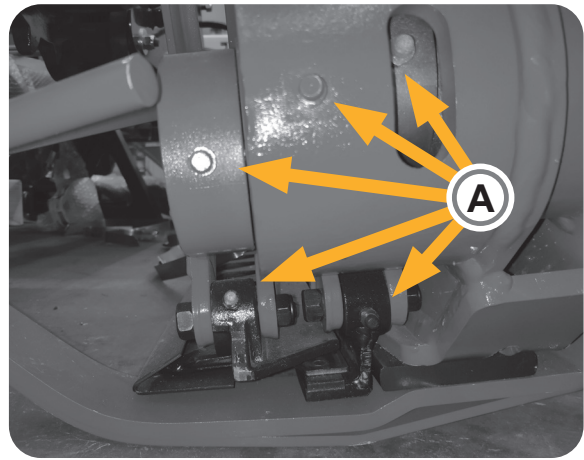
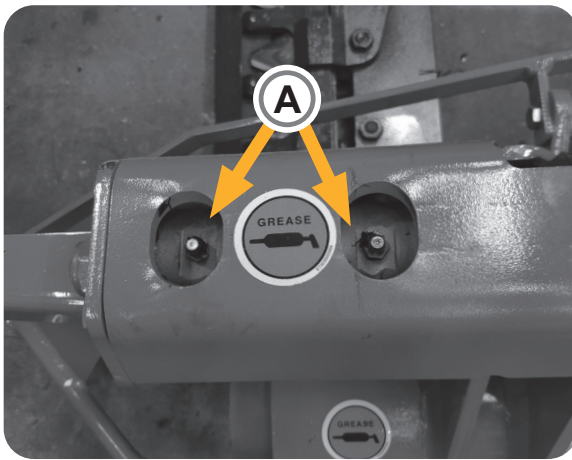

9.8.2 - JOINT ATTACHMENT

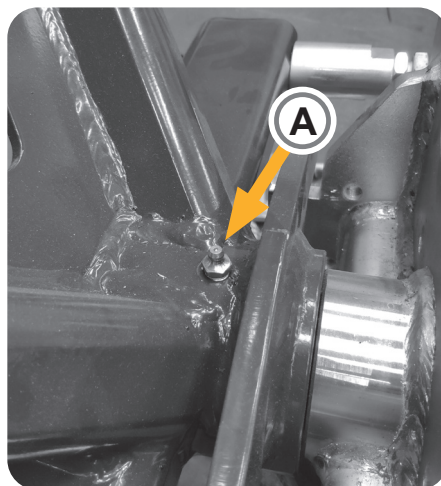

9.9 - PERIODIC REPLACEMENT OF THE SAFETY COMPONENTS

To guarantee safety at any moment when driving and using the machine, the operator is required to replace the components listed below:

- Hydraulic pipes every 4000 hours / 6 years

9.10 - MAINTENANCE OPERATIONS

MAINTENANCE FREQUENCY

Component		Period				
		After the first 4 hours	Every 8 Hours / Daily	Every 40 hours / Weekly	Every 4000 hours / 6 years	
BLADE	Check		X			
BLADE HOLDER	Check		X			
CUTTER BAR	Cleaning		X			
	Greasing		X			
HYDRAULIC PIPES	Check		X			
	Replacement				X	

^(A) Only for the first check.

10 - INSTRUCTIONS FOR EMERGENCY SITUATIONS

10.1 - FIRE

In case of fire, use a fire extinguisher according to the standards in force. In case the machine is on fire or it is near a fire, exit the driver's cab immediately, raise the alarm in the construction site and contact the fire brigade.

11 - TIGHTENING TABLES

11.1 - CLASSES OF COARSE PITCH BOLTS

Diameter (mm)	Pitch (mm)	Friction coefficient	8.8		10.9		12.9	
			Preload	Tightening torque	Preload	Tightening torque	Preload	Tightening torque
			N	Nm	N	Nm	N	Nm
M2	0.40	0.14	899	0.37	1,264.3	0.52	1,517.1	0.63
M2.5	0.45	0.14	1499.8	0.77	2,109.1	1.08	2,531	1.30
M3	0.50	0.14	2,251.9	1.34	3,166.7	1.88	3,800	2.26
M3.5	0.60	0.14	3,022.6	2.05	4,250.6	2.89	5,100.7	3.47
M4	0.70	0.14	3,901.9	3.06	5,487	4.30	6,584.4	5.16
M5	0.80	0.14	6,393.7	6.04	8,991.1	8.50	10,789.3	10.20
M6	1.00	0.14	8,998.2	10.37	12,653.7	14.59	15,184.4	17.51
M7	1.00	0.14	13,199.2	17.21	18,561.4	24.20	22,273.6	29.04
M8	1.25	0.14	16,531.2	25.07	23,247	35.26	27,896.5	42.31
M10	1.50	0.14	26,334.8	49.52	37,033.3	69.64	44,439.9	83.56
M12	1.75	0.14	38,408	84.84	54,011.2	119.31	64,813.5	143.17
M14	2.00	0.14	52,522.4	135.13	73,859.6	190.02	88,631.5	228.03
M16	2.00	0.14	72,728.5	211.61	102,274.4	297.58	122,729.3	357.09
M18	2.50	0.14	87,372.3	290.32	123,711	402.26	148,453.2	489.92
M20	2.50	0.14	113,494.2	412.78	156,601.2	580.47	191,521.5	696.56
M22	2.50	0.14	141,583.7	567.58	199,102.1	798.16	238,922.5	957.80
M24	3.00	0.14	16,523.6	713.68	229,955.1	1,003.61	275,946.1	1,204.33
M27	3.00	0.14	21,488.3	1,050.16	302,179.2	1,476.79	362,615	1,772.15
M30	3.50	0.14	26,541.2	1,428.97	367,792.3	2,009.49	441,350.8	2,411.39
M33	3.50	0.14	326,115.9	1,940.86	458,600.5	2,729.33	550,320.6	3,275.19
M36	4.00	0.14	382,483.6	2,496.81	537,867.6	3,511.14	645,441.1	4,213.37
M39	4.00	0.14	459,805.2	3,241.92	646,601	4,558.96	775,921.3	5,470.75
M42	4.50	0.14	525,878	4,010.93	739,516	5,640.37	887,419.2	6,768.44
M45	4.53	0.14	618,303.6	5,039.09	869,489.3	7,086.23	1,043,387	8,503.47
M48	5.00	0.14	691,725.8	6,036.23	972,739.4	8,488.45	1,167,287	10,186.14

11.2 - CLASSES OF FINE PITCH BOLTS

Diameter (mm)	Pitch (mm)	Friction coefficient	8.8		10.9		12.9	
			Preload	Tightening torque	Preload	Tightening torque	Preload	Tightening torque
			N	Nm	N	Nm	N	Nm
M8	1	0.14	18,159.1	27.05	25,536.2	38.04	30,643.4	45.65
M10	1	0.14	28,350.1	52.55	39,867.3	73.89	47,840.8	88.67
M10	1	0.14	30,443.3	55.61	42,810.8	78.2	51,373	93.84
M12	2	0.14	40,811.6	89.06	57,391.3	125.24	68,869.5	150.29
M12	1	0.14	43,338.4	93.41	60,944.6	131.36	73,133.5	157.63
M14	2	0.14	58,691.9	147.85	82,535.4	207.91	99,042.5	249.49
M16	2	0.14	79,175.5	226.12	111,340.6	317.98	133,608.7	381.57
M18	2	0.14	95,503.3	310.05	134,301.6	436	161,161.9	523.2
M 18	2	0.14	103,155.2	329.35	145,062.1	463.15	174,074.5	555.77
M20	2	0.14	121,772.4	436.34	171,242.5	613.61	205,491	736.33
M20	2	0.14	130,638.1	461.1	183,709.9	648.42	220,451.9	778.1
M22	2	0.14	151,067.8	597.49	212,439.1	840.22	254,927	1,008.27
M22	2	0.14	160,663.6	626.82	225,933.2	881.46	271,119.8	1,057.75
M24	2	0.14	183,386.5	780.67	257,887.3	1,097.82	309,464.8	1,371.38
M24	2	0.14	194,192.1	816.24	273,082.6	1,147.84	327,699.1	1,377.41
M27	2	0.14	238,370.1	1,139.34	335,207.9	1,602.2	402,249.5	1,922.64
M30	2	0.14	299,914	1,590.29	421,754.2	2,236.34	506,105	2,683.61
M33	2	0.14	368,980.2	2,136.49	518,878.4	3,004.43	622,654	3,605.32
M36	3	0.14	413,097.9	2,652.26	580,918.9	3,729.74	697,102.7	4,475.68
M39	3	0.14	494,054.1	3,430.3	694,763.5	4,823.86	833,716.1	5,788.63
M42	3	0.14	582,537.4	4,349.18	819,193.3	6,116.04	983,031.9	7,339.24
M45	3	0.14	676,135.5	5,401.43	950,815.6	7,595.77	1,140,979	9,114.92
M48	3	0.14	774,830.6	6,594.93	1,089,606	9,274.12	1,307,527	11,128.94
M45	4.53	0.14	618,303.6	5,039.09	869,489.3	7,086.23	1,043,387	8,503.47
M48	5.00	0.14	691,725.8	6,036.23	972,739.4	8,488.45	1,167,287	10,186.14

11.3 - FITTINGS TIGHTENING TABLE

Series	Ø Pipe	THREADING - TIGHTENING TORQUE					
		Ø Threaded metric	Form B MT (Nm)	Shape E MT (Nm)	Ø Metric Gas	Shape B MT (Nm)	Shape E MT (Nm)
Light	6	M 10x1.0	18	18	G 1/8	18	18
	8	M 12 x 1.5	30	25	G 1/4	35	35
	10	M 14 x 1.5	45	45	G 1/4	35	35
	12	M 16 x 1.5	65	55	G 3/8	70	70
	15	M 18 x 1.5	80	70	G 1/2	140	90
	18	M 22 x 1.5	140	125	G 1/2	100	90
	22	M 26 x 1.5	190	180	G 3/4	180	180
	28	M 33 x 2.0	340	310	G 1	330	310
	35	M 42 x 2.0	500	450	G 1 1/4	540	450
	42	M 48 x 2.0	630	540	G 1 1/2	630	540
Strong	6	M 12 x 1.5	35	35	G 1/4	55	40
	8	M 14 x 1.5	55	45	G 1/4	55	40
	10	M 16 x 1.5	70	70	G 3/8	90	80
	12	M 18 x 1.5	110	90	G 3/8	90	80
	14	M 20 x 1.5	150	125	G 1/2	150	115
	16	M 22 x 1.5	170	135	G 1/2	130	115
	20	M 27 x 2.0	270	180	G 3/4	270	180
	25	M 33 x 2.0	410	310	G 1	340	310
	30	M 42 x 2.0	540	450	G 1 1/4	540	450
	38	M 48 x 2.0	700	540	G 1 1/2	700	540



McConnel Limited, Temeside Works, Ludlow, Shropshire SY8 1JL. England.
Telephone: 01584 873131. Facsimile: 01584 876463. www.mcconnel.com