

Publication 742
May 2013
Part No. 22675.42
Revised: 01.10.13



McCONEL

ROBOCUT Pure

REMOTE CONTROLLED MOWER

Operator & Parts Manual



IMPORTANT VERIFICATION OF WARRANTY REGISTRATION



DEALER WARRANTY INFORMATION & REGISTRATION VERIFICATION

It is imperative that the selling dealer registers this machine with McConnel Limited before delivery to the end user – failure to do so may affect the validity of the machine warranty.

To register machines go to the McConnel Limited web site at www.mcconnel.com, log onto 'Dealer Inside' and select the 'Machine Registration button' which can be found in the Service Section of the site. Confirm to the customer that the machine has been registered in the section below.

Should you experience any problems registering a machine in this manner please contact the McConnel Service Department on 01584 875848.

Registration Verification

Dealer Name:
Dealer Address:
Customer Name:
Date of Warranty Registration:/...../..... Dealer Signature:

NOTE TO CUSTOMER / OWNER

Please ensure that the above section above has been completed and signed by the selling dealer to verify that your machine has been registered with McConnel Limited.

IMPORTANT: During the initial 'bedding in' period of a new machine it is the customer's responsibility to regularly inspect all nuts, bolts and hose connections for tightness and re-tighten if required. New hydraulic connections occasionally weep small amounts of oil as the seals and joints settle in – where this occurs it can be cured by re-tightening the connection – *refer to torque settings chart below*. The tasks stated above should be performed on an hourly basis during the first day of work and at least daily thereafter as part of the machines general maintenance procedure.

CAUTION: DO NOT OVER TORQUE HYDRAULIC FITTINGS AND HOSES

TORQUE SETTINGS FOR HYDRAULIC FITTINGS

HYDRAULIC HOSE ENDS		
BSP	Setting	Metric
1/4"	18 Nm	19 mm
3/8"	31 Nm	22 mm
1/2"	49 Nm	27 mm
5/8"	60 Nm	30 mm
3/4"	80 Nm	32 mm
1"	125 Nm	41 mm
1.1/4"	190 Nm	50 mm
1.1/2"	250 Nm	55 mm
2"	420 Nm	70 mm

PORT ADAPTORS WITH BONDED SEALS		
BSP	Setting	Metric
1/4"	34 Nm	19 mm
3/8"	47 Nm	22 mm
1/2"	102 Nm	27 mm
5/8"	122 Nm	30 mm
3/4"	149 Nm	32 mm
1"	203 Nm	41 mm
1.1/4"	305 Nm	50 mm
1.1/2"	305 Nm	55 mm
2"	400 Nm	70 mm

WARRANTY POLICY

WARRANTY REGISTRATION

All machines must be registered, by the selling dealer with McConnel Ltd, before delivery to the end user. On receipt of the goods it is the buyer's responsibility to check that the Verification of Warranty Registration in the Operator's Manual has been completed by the selling dealer.

1. LIMITED WARRANTIES

- 1.01. *All machines supplied by McConnel Ltd are warranted to be free from defects in material and workmanship from the date of sale to the original purchaser for a period of 12 months, unless a different period is specified.*
- 1.02. *All spare parts supplied by McConnel Ltd and purchased by the end user are warranted to be free from defects in material and workmanship from the date of sale to the original purchaser for a period of 6 months. All parts warranty claims must be supported by a copy of the failed part invoice to the end user. We cannot consider claims for which sales invoices are not available.*
- 1.03. *The warranty offered by McConnel Ltd is limited to the making good by repair or replacement for the purchaser any part or parts found, upon examination at its factory, to be defective under normal use and service due to defects in material or workmanship. Returned parts must be complete and unexamined. Pack the component(s) carefully so that any transit damage is avoided. All ports on hydraulic items should be drained of oil and securely plugged to prevent seepage and foreign body ingress. Certain other components, electrical items for example, may require particular care when packing to avoid damage in transit.*
- 1.04. *This warranty does not extend to any product from which McConnel Ltd's serial number plate has been removed or altered.*
- 1.05. *This warranty does not apply to any part of the goods, which has been subjected to improper or abnormal use, negligence, alteration, modification, fitment of non-genuine parts, accident damage, or damage resulting from contact with overhead power lines, damage caused by foreign objects (e.g. stones, iron, material other than vegetation), failure due to lack of maintenance, use of incorrect oil or lubricants, contamination of the oil, or which has served its normal life. This warranty does not apply to any expendable items such as blades, belts, clutch linings, filter elements, flails, flap kits, skids, soil engaging parts, shields, guards, wear pads, pneumatic tyres or tracks.*
- 1.06. *Temporary repairs and consequential loss - i.e. oil, downtime and associated parts are specifically excluded from the warranty.*
- 1.07. *Warranty on hoses is limited to 12 months and does not include hoses which have suffered external damage. Only complete hoses may be returned under warranty, any which have been cut or repaired will be rejected.*
- 1.08. *Machines must be repaired immediately a problem arises. Continued use of the machine after a problem has occurred can result in further component failures, for which McConnel Ltd cannot be held liable, and may have safety implications.*
- 1.09. *If in exceptional circumstances a non McConnel Ltd part is used to effect a repair, warranty reimbursement will be at no more than McConnel Ltd's standard dealer cost for the genuine part.*
- 1.10. *Except as provided herein, no employee, agent, dealer or other person is authorised to give any warranties of any nature on behalf of McConnel Ltd.*
- 1.11. *For machine warranty periods in excess of 12 months the following additional exclusions shall apply:*
 - 1.11.1. *Hoses, exposed pipes and hydraulic tank breathers.*
 - 1.11.2. *Filters.*
 - 1.11.3. *Rubber mountings.*
 - 1.11.4. *External electric wiring.*
 - 1.11.5. *Bearings and seals.*

- 1.12. *All service work, particularly filter changes, must be carried out in accordance with the manufacturer's service schedule. Failure to comply will invalidate the warranty. In the event of a claim, proof of the service work being carried out may be required.*
- 1.13. *Repeat or additional repairs resulting from incorrect diagnosis or poor quality previous repair work are excluded from warranty.*

NB Warranty cover will be invalid if any non-genuine parts have been fitted or used. Use of non-genuine parts may seriously affect the machine's performance and safety. McConnel Ltd cannot be held responsible for any failures or safety implications that arise due to the use of non-genuine parts.

2. REMEDIES AND PROCEDURES

- 2.01. *The warranty is not effective unless the Selling Dealer registers the machine, via the McConnel Ltd web site and confirms the registration to the purchaser by completing the confirmation form in the operator's manual.*
- 2.02. *Any fault must be reported to an authorised McConnel Ltd dealer as soon as it occurs. Continued use of a machine, after a fault has occurred, can result in further component failure for which McConnel Ltd cannot be held liable.*
- 2.03. *Repairs should be undertaken within two days of the failure. Claims submitted for repairs undertaken more than 2 weeks after a failure has occurred, or 2 days after the parts were supplied will be rejected, unless the delay has been authorised by McConnel Ltd. Please note that failure by the customer to release the machine for repair will not be accepted as a reason for delay in repair or submitting warranty claims.*
- 2.04. *All claims must be submitted, by an authorised McConnel Ltd Service Dealer, within 30 days of the date of repair.*
- 2.05. *Following examination of the claim and parts, McConnel Ltd will pay, at their discretion, for any valid claim the invoiced cost of any parts supplied by McConnel Ltd and appropriate labour and mileage allowances if applicable.*
- 2.06. *The submission of a claim is not a guarantee of payment.*
- 2.07. *Any decision reached by McConnel Ltd is final.*

3. LIMITATION OF LIABILITY

- 3.01. *McConnel Ltd disclaims any express (except as set forth herein) and implied warranties with respect to the goods including, but not limited to, merchantability and fitness for a particular purpose.*
- 3.02. *McConnel Ltd makes no warranty as to the design, capability, capacity or suitability for use of the goods.*
- 3.03. *Except as provided herein, McConnel Ltd shall have no liability or responsibility to the purchaser or any other person or entity with respect to any liability, loss, or damage caused or alleged to be caused directly or indirectly by the goods including, but not limited to, any indirect, special, consequential, or incidental damages resulting from the use or operation of the goods or any breach of this warranty. Notwithstanding the above limitations and warranties, the manufacturer's liability hereunder for damages incurred by the purchaser or others shall not exceed the price of the goods.*
- 3.04. *No action arising out of any claimed breach of this warranty or transactions under this warranty may be brought more than one (1) year after the cause of the action has occurred.*

4. MISCELLANEOUS

- 4.01. *McConnel Ltd may waive compliance with any of the terms of this limited warranty, but no waiver of any terms shall be deemed to be a waiver of any other term.*
- 4.02. *If any provision of this limited warranty shall violate any applicable law and is held to be unenforceable, then the invalidity of such provision shall not invalidate any other provisions herein.*
- 4.03. *Applicable law may provide rights and benefits to the purchaser in addition to those provided herein.*



DECLARATION OF CONFORMITY

Conforming to EU Machinery Directive 2006/42/EC

We,

McCONNEL LIMITED, Temeside Works, Ludlow, Shropshire SY8 1JL, UK

Hereby declare that:

The Product; *Radio Controlled Tracked Mower*

Product Code; *RMOW*

Serial No. & Date Type

Manufactured in; *Italy*

Complies with the required provisions of the Machinery Directive 2006/42/EC
The machinery directive is supported by the following harmonized standards;

- BS EN ISO 12100 (2010) Safety of machinery – General principles for design – Risk assessment and risk reduction.
- BS EN 349 (1993) + A1 (2008) Safety of machinery - Minimum distances to avoid the entrapment with human body parts.
- BS EN 953 (1997) + A1 (2009) Safety of machinery - Guards general requirements for the design and construction of fixed and movable guards.
- BS EN 4413 (2010) Hydraulic fluid power. Safety requirements for systems and their components.

McCONNEL LIMITED operates an ISO 9001:2008 quality management system, certificate number: FM25970.

This system is continually assessed by the;

British Standards Institution (BSI), Beech House, Milton Keynes, MK14 6ES, UK
BSI is accredited by UK Accreditation Service, accreditation number: UKAS 003.

The EC declaration only applies if the machine stated above is used in accordance with the operating instructions.

Signed *Responsible Person*
CHRISTIAN DAVIES on behalf of McCONNEL LIMITED

Status: *General Manager*

Date: *September 2015*

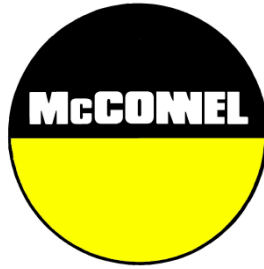

For Safety and Performance...

ALWAYS READ THIS BOOK FIRST

McCONEl LIMITED

**Temeside Works
Ludlow
Shropshire
England**

**Telephone: 01584 873131
www.mcconnel.com**

NOISE STATEMENT

The equivalent daily personal noise exposure from this machine measured at the operators' ears is within the range 78 – 85 dB, these figures apply to a normal distribution of use where the noise fluctuates between zero and maximum. The figures assume that the machine is fitted to a tractor with a 'quiet' cab with the windows closed in a generally open environment. We recommend that the windows are kept closed. With the cab rear window open the equivalent daily personal noise exposure will increase to a figure within the range 82 – 88 dB. At an equivalent daily noise exposure level of 85 – 90 dB ear protection is recommended and must always be used if any window is left open.

LIST OF CONTENTS

	<i>Page No.</i>
Operator Section	
General Information	1
Features & Specifications	2
Safety Information	3
Safety Decals & Warnings	6
Safety Devices & Emergency Stop	8
Machine Delivery	9
Machine Overview	10
Radio Control Unit	13
Starting the Engine	14
Driving & Manoeuvring	15
LCD Display	18
Emergency Manual Control Unit	21
Pre-Operation Checks	23
Operation	24
Maintenance	26
Electrical System Fuses & Relays	37
Troubleshooting	40
Parts Section	
Chassis Assembly	44
Upper & Lower Roller Assemblies	46
Tensioner Assembly	48
Tracks	50
Equipment Mounting Assembly	52
Engine Covers Assembly	54
Machine Covers Assembly	56
Roll Bar Assembly	58
Diesel Engine Assembly	60
Diesel Engine Components	64
Pumps Assembly	66
Actuator Assembly	68
Diesel Fuel Circuit	70
Oil Tank Assembly	72
Electrical Components	74
Electrical Wiring	78
Remote Control	80
Intake & Drain Pumps	82
Tracks Hydraulic Circuit	84
Hydraulic Rams Circuit	86
Hydraulic Equipment Circuit	88
Machine Decal Kit	90
Flailhead Assembly	92
Belt Drive Assembly	96
Rotors & Flails Options	98
Flailhead Hydraulic Installation	100
Flailhead Decal Kit	102

GENERAL INFORMATION

Always read this manual before attempting to operate the machine – whenever any doubt exists contact your dealer or the McConnel Service Department for advice and assistance.

Use only McConnel Genuine Service Parts on McConnel Equipment and Machines

DEFINITIONS – *The following definitions apply throughout this manual:*

WARNING

An operating procedure, technique etc., which –
can result in personal injury or loss of life if not observed carefully.

CAUTION

An operating procedure, technique etc., which –
can result in damage to either machine or equipment if not observed carefully.

NOTE

An operating procedure, technique etc., which is –
considered essential to emphasis.

LEFT AND RIGHT HAND

These terms are applicable to the machine when it is viewed from the rear facing forwards.

Note: The illustrations in this manual are for instructional purposes only and may on occasion not show some components in their entirety. In some instances an illustration may appear slightly different to that of your particular model but the general procedure will be the same. E&OA.

MACHINE & DEALER INFORMATION

Record the Serial Number of your machine on this page and always quote this number when ordering parts. Whenever information concerning the machine is requested remember also to state the make and model of tractor to which the machine is fitted.

Machine Serial Number:

Installation Date:

Machine Model details:

Dealer Name:

Dealer Address:

Dealer Telephone No:

Dealer Email Address:

FEATURES & SPECIFICATIONS

RoboCut Pure

- 40HP (29kW) 3 Cylinder ISUZU Diesel Engine
- Tracked Carriage Hydraulically Driven via Piston Pumps
- Mechanical Track Tensioning
- Remote Controlled Operation (up to 150m range)
- Rubber Tracks
- Independent Cooling System for Hydraulic Circuits
- Electronically Controlled, Hydraulically Powered Flail Head
- 0-5 km/h Forward / Reverse Speed with Slow / Medium / Fast Settings
- 21 Litre Fuel Tank Capacity
- 1280mm Carriage Width
- 1.3m Flail Head capable of cutting materials up to 30mm diameter
- Machine Weight 1000kg

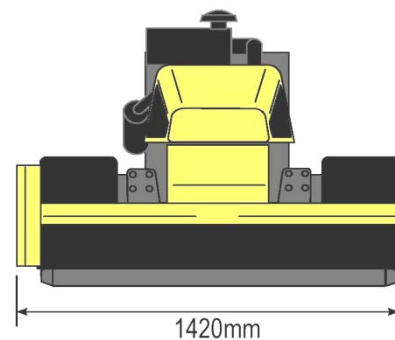
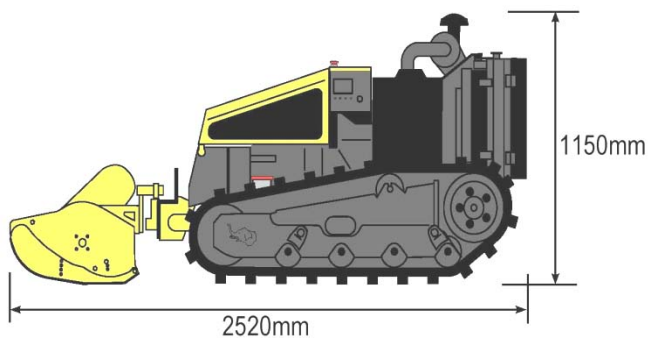



This machine has the potential to be extremely dangerous - in the wrong hands it can kill or maim; It is therefore imperative that both owner and operator of the machine reads and understands the following section to ensure they are fully aware of the dangers that do, or may exist, and their responsibilities surrounding the use and operation of the machine.

The operator of this machine is responsible not only for their own safety but equally for the safety of others who may come into the close proximity of the machine, as the owner you are responsible for both.

When the machine is not in use it should be parked on a firm level site with the cutting head resting on the ground and the starting key removed.

In the event of any fault being detected with the machine's operation it must be stopped immediately and not used again until the fault has been corrected by a qualified technician.

- *Before starting the machine the operator must read and understand all aspects of use and maintenance of the machine as stated in this manual.*
- *The machine must only be used by a responsible adult who is familiar with all aspects relating to safe operation.*
- *The machine must not be operated by children or non-authorized persons.*
- *Operators must know the meaning of all operation and safety decals on both the machine and the remote control unit.*
- *Operators must know the procedure for switching the machine off normally and by using the Emergency Stop.*
- *Do not attempt to use the machine if the Emergency Stop switch is damaged or malfunctioning.*
- *Never use the machine with safety guarding removed or defective.*

- *Operators should practice operation on flat open ground to familiarise themselves with driving and manoeuvring the machine before attempting to use it on sloping ground.*
- *Operators should practice manoeuvring the machine around obstacles without the flail head running before using the machine for work purposes.*
- *Never operate the machine when your vision is blocked by obstacles such as vehicles, buildings, hedges etc.; move to a position where you have an un-interrupted view of the machine.*
- *Never operate the machine standing directly in the line of travel.*
- *Do not use the machine on sand piles, gravel, or similar materials.*
- *Only operate the machine in good light conditions.*
- *Never run the machine in an enclosed area or building.*
- *Keep the machine clean to avoid build ups of dry materials that could ignite on hot components.*
- *Never stand directly below a machine that is operating or parked on a slope.*
- *Always operate the joystick control slowly; rapid or jerky movements can cause the machine to rear up causing loss of control.*
- *When operating the machine with the flail head running the operator must remain at least 5 metres away from the machine; always switch the flail head off before approaching it.*
- *When using the machine the operator should place themselves in a position that provides optimum visibility over the work area.*
- *Never leave a running machine unattended; always switch the engine off and remove the ignition key.*
- *Always stop and switch the machine off if persons or animals enter the work area, do not restart the machine until they are at a safe distance.*
- *Never use the machine to perform tasks it was not designed for.*
- *Never ride, or allow others to ride on the machine.*
- *Always inspect the work area prior to operation and remove stones, glass, metal, wire or any other foreign objects that are hazardous. Immovable hazards should be 'marked' so they can be avoided.*
- *Take extra care when operating the machine on slopes or uneven ground, there is increased risk of objects being thrown from the flail head when working in these conditions.*
- *The machine can be used on slopes of up to 50° (maximum) providing the surface is dry and firm.*

- *Should a machine overturn, a suitable crane or winch should be used to recover it, keep all persons at a safe distance before and during recovery.*
- *Do not operate the machine in foggy or frosty conditions as there is increased risk of accidents.*
- *Take extra care when working in close proximity to electrical cables; in some circumstances, operating the machine under overhead power lines can result in loss of radio signal causing the engine to deactivate.*
- *Do not operate the machine close to vehicles or properties where there is risk of damage by objects accidentally thrown from the flail head.*
- *It is the user's responsibility to protect persons in or near the work zone.*
- *When servicing or maintaining the machine no one should be allowed beneath it when it is raised unless it is securely supported on suitable ramps or stands.*
- *Never attempt to service or maintain the machine whilst it is running; always switch off the engine and remove the starting key.*
- *When transporting the machine on another vehicle or trailer the engine must be switched off and the machine chocked and secured using suitable ropes or chains.*
- *Check the condition of the flails and fixings on a regular basis; never use the machine with damaged/missing flails or loose fixings.*
- *Always clean the machine after use; care must be taken if the machine is hot. Never use solvent based chemicals for cleaning.*
- *When operating in excessively dusty conditions work may need to be interrupted on a regular basis to remove any build ups of dust on components that could cause overheating.*
- *Always press the Emergency Stop switch before refuelling.*
- *Wherever possible refuel the machine before work when the engine is cold. If refuelling during work, switch off the engine and allow it to cool before adding fuel.*
- *Test the Emergency Stop switch before each period of work to ensure it functions correctly.*
- *Never leave the machine, ignition key and control unit unattended where it could be started and used by un-authorized persons.*
- *Any inspection, service or maintenance of the flail head must only be performed with machine switched off and the starting key removed.*
- *Always wear safety gloves and glasses when performing service or maintenance on the flail head.*
- *Flail head must always be switched off when manoeuvring outside of the work zone.*

SAFETY & WARNING DECALS

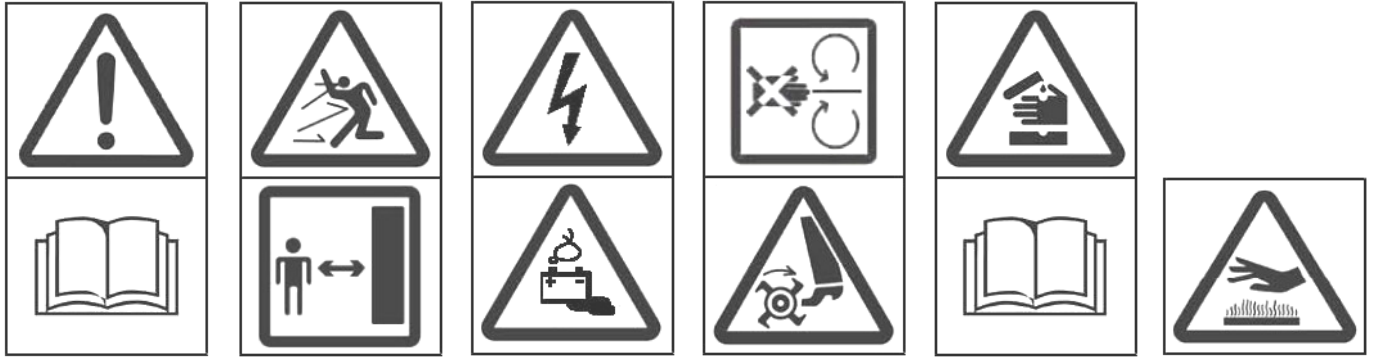

1.

2.

3.

4.

5.

6.



7.



8.



9.



10.

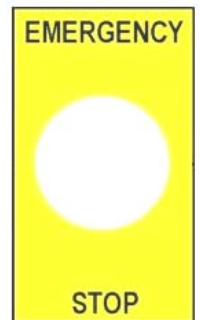

11.



12.



13.

1. WARNING: Read the manual first.
2. DANGER: Risk of thrown objects, keep your distance.
3. DANGER: Electrical voltage and harmful substances.
4. DANGER: Rotating components, keep clear.
5. DANGER: Acid, read the user and maintenance manual.
6. DANGER: Hot components, risk of burns.
7. WARNING: Do not lubricate or service moving components, stop the machine first.
8. WARNING: Do not lift machine by the roll bar (if applicable) use hooks on machine frame.
9. WARNING: Do not use high pressure washer on or near machines electrical components.
10. ADVISORY: Machine lifting point.
11. ADVISORY: Emergency Stop button
12. ADVISORY: Always wear safety footwear when using the machine.
13. ADVISORY: Always wear ear defenders and safety glasses when using the machine.

Decal Locations

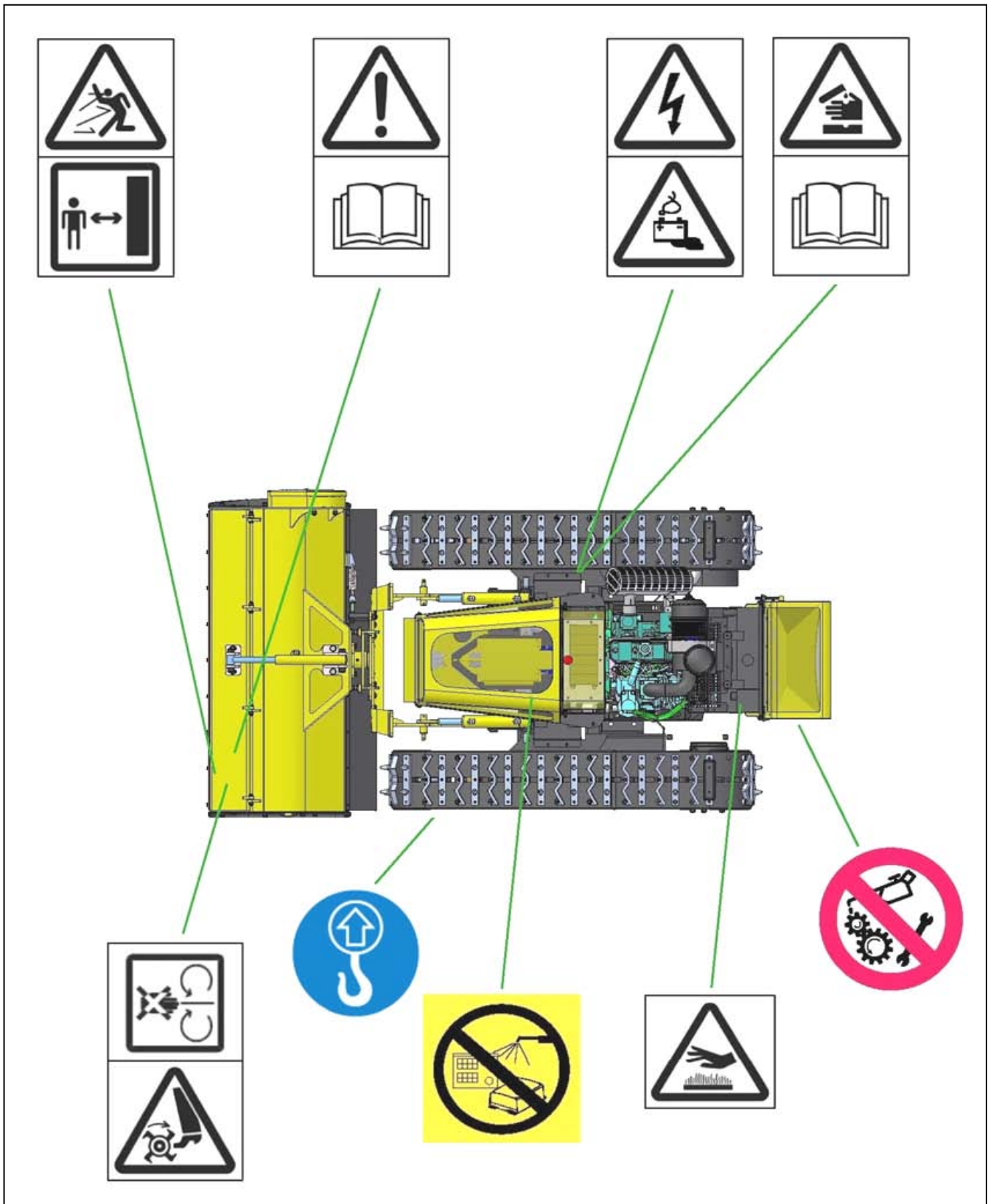

SAFETY DEVICES & EMERGENCY STOP

Automatic Emergency Safety Features

As the RoboCut is operated by remote control and the user is not directly operating the driving elements of the machine specific safety features have been built in to protect the user, third party persons and the machine itself; these are as follows

Danger / Risk Situation	Automatic Safety Feature
Machine beyond signal reception area or radio signal blocked.	EMERGENCY STOP will activate.
Radio signal failure.	EMERGENCY STOP will activate.
Another machine on same frequency operating in the area.	EMERGENCY STOP will activate.

Manual Emergency Safety Feature

In addition to the automatic safety features stated above the operator can immediately stop the machine either by pressing the Emergency Stop button located on the remote control unit or by pressing the Emergency Stop button located on the top panel of the machine itself.

In all instances stated above, emergency stopping of the machine will take a maximum of 0.2 seconds from execution of the automatic or manual command and the following actions will occur;

- Engine will be switched off
- Ignition will be turned off.
- Machine movement will be halted.
- Electrical voltage will be deactivated.
- Entire electrical system will be disabled.

In the unlikely event of movement malfunction

If machine movements perform in an unexpected or incorrect manner follow the instructions below;

- 1) Release the forwards/backwards movement joystick – *the control is equipped with automatic zero position; on release it will automatically return to the central (stop) position, this action activates the track brakes.*
- 2) Press the Emergency Stop button on the control unit.

DANGER! Do not approach the machine if it is moving.

- 3) Press the machine's Emergency Stop button.
- 4) Turn the ignition key into the off position (*anti-clockwise*) and remove the key.

Contact your Authorised Dealer or McConnel Service – do not attempt to operate the machine until advice has been sought.

MACHINE DELIVERY

The machine will be delivered ready for use having been pre-filled with all necessary lubricants and fluids other than fuel.

Before use all packaging must be removed and the transport fasteners loosened.

The reception antenna will be supplied as a loose item and must be screwed onto the machines receiver prior to use.

The standard items supplied will be as follows:

Standard Equipment

- *Machine with Mounted Receiver*
- *Transmitter and Battery Pack*
- *Reserve Battery Pack*
- *Battery Charger 12V CA*
- *Antenna*
- *Belt for the Radio Control*
- *Ignition Key*
- *Use and Maintenance Manual for Machine*
- *Use and Maintenance Manual for Transmitter*
- *Use and Maintenance Manual for Engine*

Machine Lifting Points

The photos below shown the machine's lifting points; the lifting eyes are located at each end of the track plates on both sides of the machine. The positions of the lifting points enable the machine to be safely raised using suitable overhead lifting equipment.

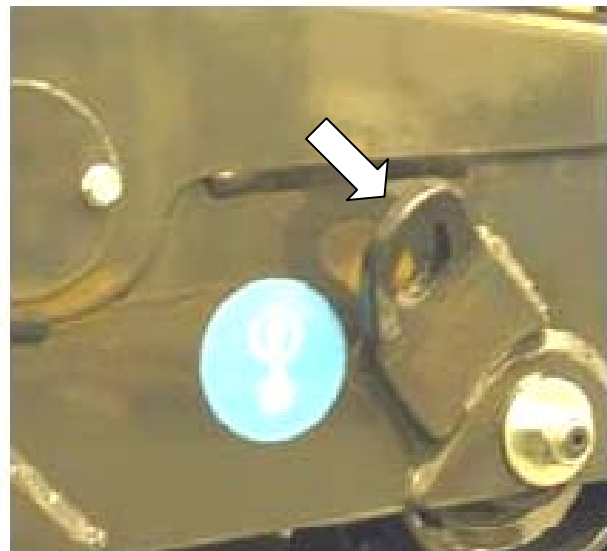
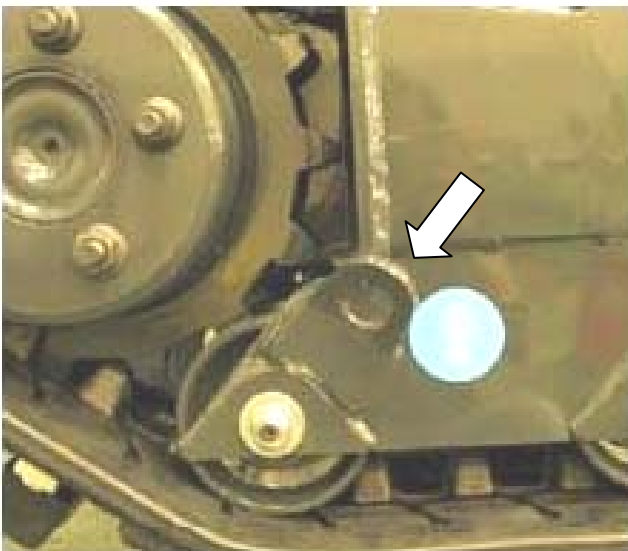

Note: All equipment used to raise the machine must have a SWL in excess of the total weight of the machine – keep all persons at a safe distance from the machine during the lifting procedure.

MACHINE OVERVIEW – Component Identification

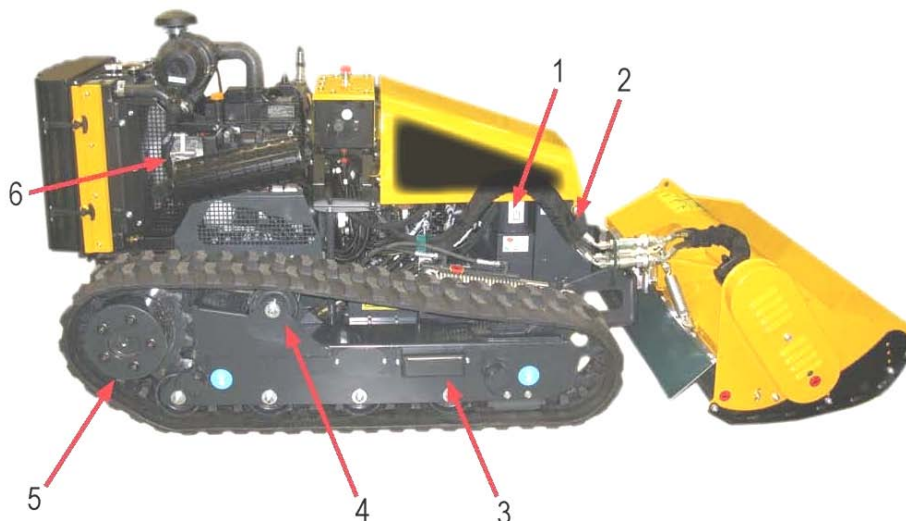

◀ Right Side View

1. Oil Tank
2. Diesel Fuel Tank
3. Track Tensioner Access
4. Track Roller
5. Drive Wheel
6. Alternator (12V)

Left Side View ▶

1. Hydraulic Motor
2. Electrics
3. Warning Beacon Mount
4. Water / Oil Radiator
5. Conveyor & Radiator Guard
6. Rubber Tracks
7. Electric Actuator
8. Track Tensioner Access
9. Lubrication Point

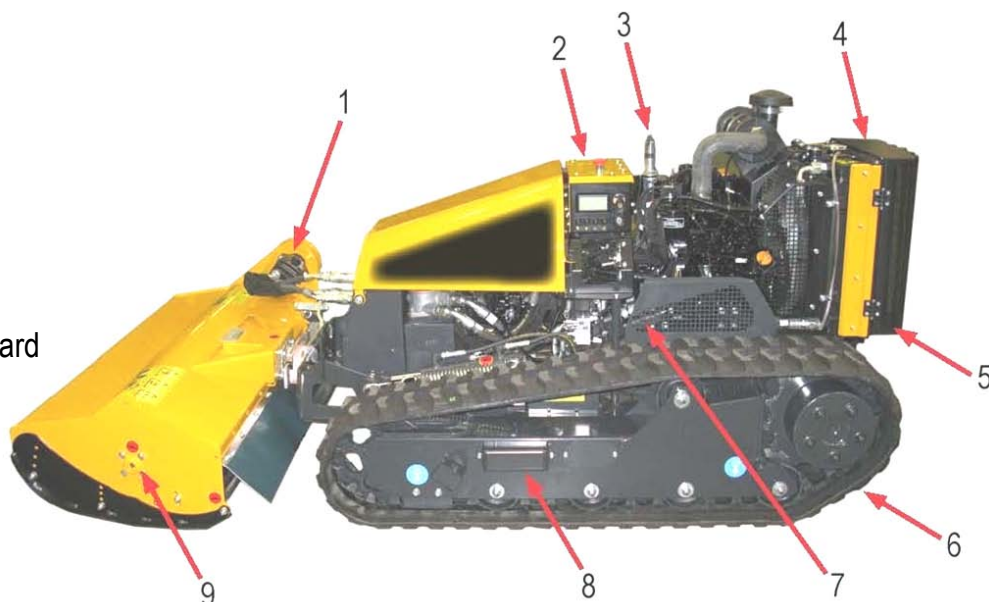

◀ Engine Top View

1. Air Filter Clogging Sensor
2. Radio Control Antenna
3. Warning Beacon Mount
4. Engine Oil Filler Plug
5. Air Filter
6. Air Filter Breather

Engine Right Side View ►

1. Radiator Filler
2. Radio Control Antenna
3. Warning Beacon Mount
4. Emergency Stop Switch
5. Electric Plug for Wired Control
6. Horn
7. Exhaust Pipe

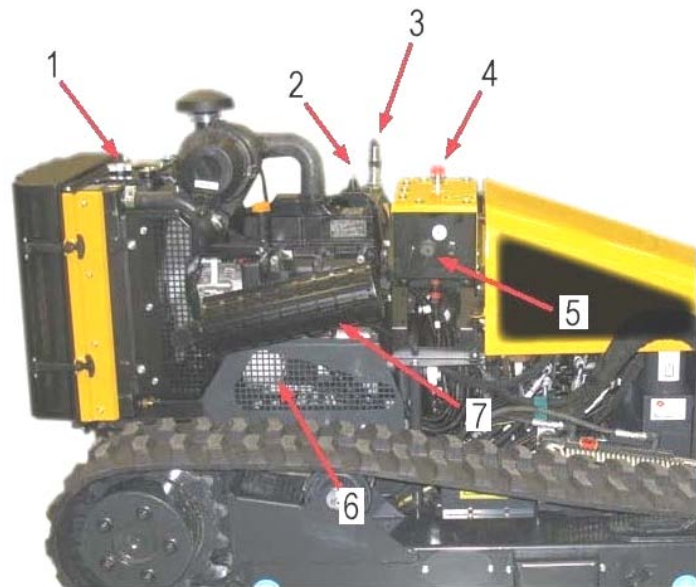

◀ Engine Left Side View

1. Emergency Stop Switch
2. Warning Beacon Mount
3. Air Filter
4. Radiator Fan Guard
5. Radiator Filler
6. Engine Oil Filler Plug
7. Secondary Fuel Filter
8. Electric Pump
9. LCD Display
10. Ignition Key

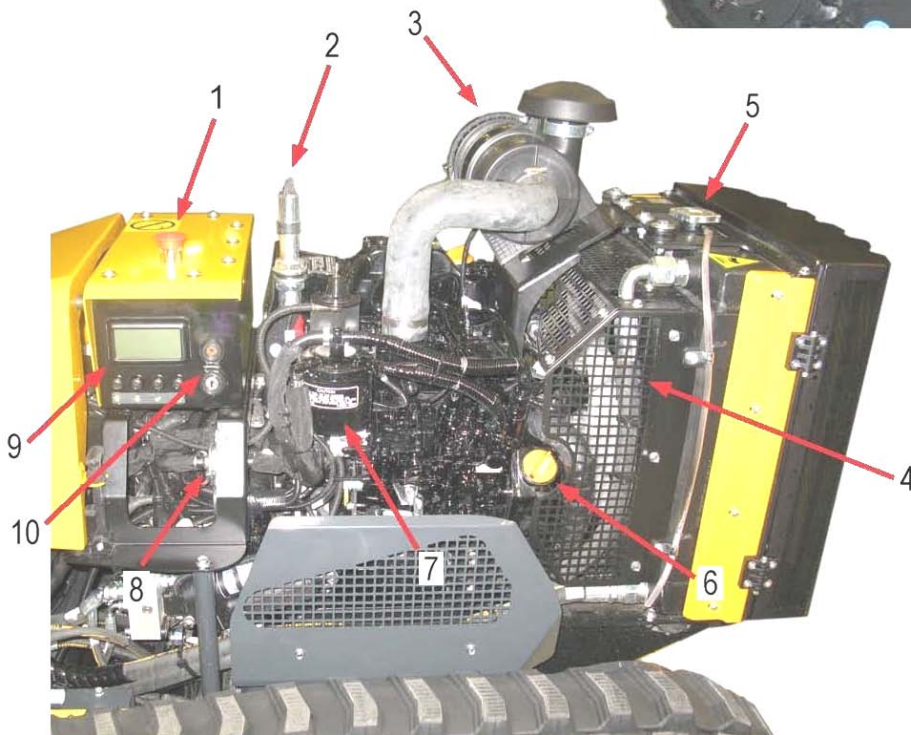

Controllers Top View ►

1. Hydraulic Oil Filler
2. Main CPU
3. Radio Control CPU
4. CANBUS Loom End Plug

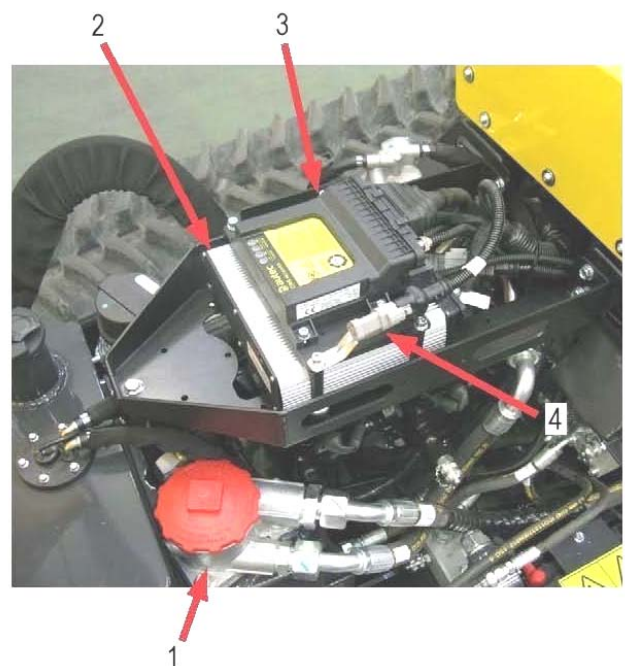

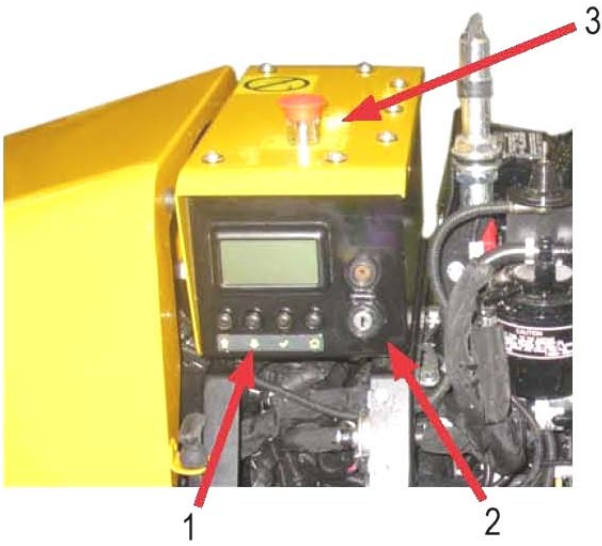

Ignition Panel Components

1. LCD Display Unit
2. Ignition Switch
3. Emergency Stop Switch

LCD Display Unit – CANBUS System

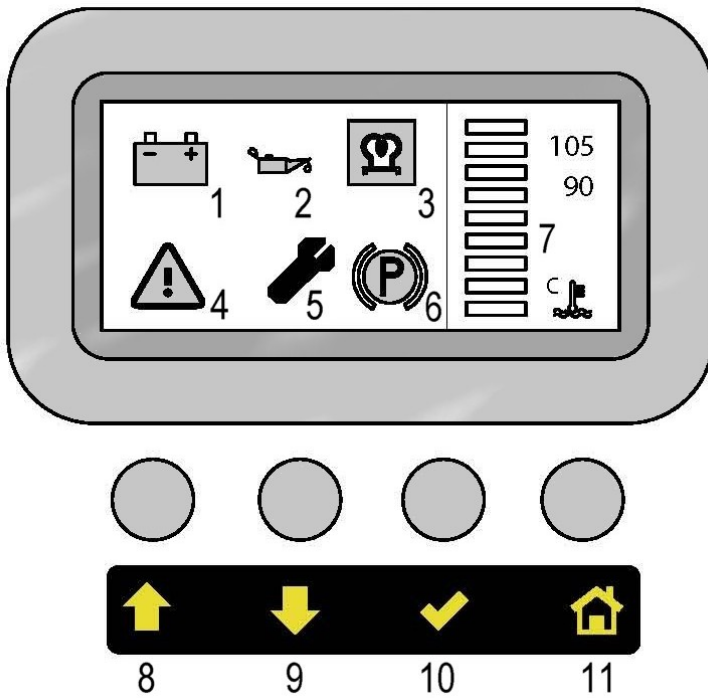

1. Battery Status
2. Oil Pressure Warning
3. Pre-heat Plugs (Optional)
4. Engine Stop
5. Service
6. Parking Brake Warning
7. Temperature Gauge (Engine Coolant)
8. Scroll Button (Up)
9. Scroll Button (Down)
10. Enter Button
11. Home Button

Radio Control Unit – Control Locations & Functions

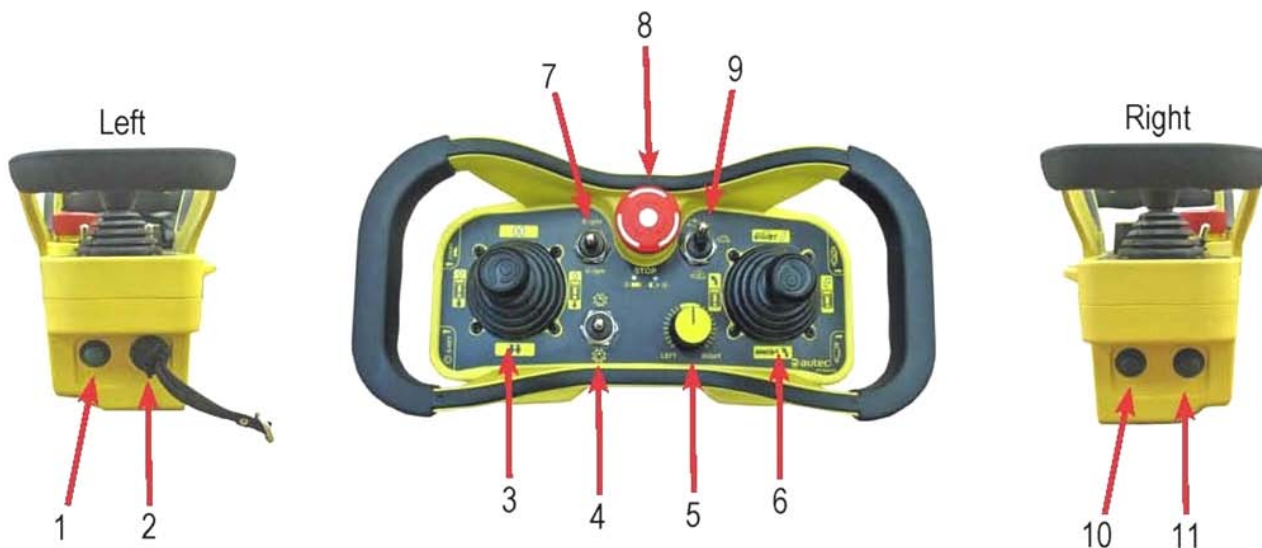

- 1. Connection / Horn
- 2. S-Key (Codified Key)

- 3. Left Joystick
 - △ Drive (Forward)
 - ▼ Drive (Reverse)



- 4. Rotor Start / Direction Selector
- 5. Steering Bias

- 6. Right Joystick
 - △ Lower Flail Head
 - ▼ Raise Flail Head
 - ◀ Steering Left
 - ▶ Steering Right

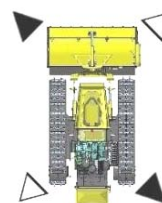

- 7. Engine Revs (+/-)
- 8. Emergency Stop Switch
- 9. Speed Control Switch
- 10. Engine Start
- 11. Engine Stop

STARTING THE ENGINE



Before attempting to start the engine ensure you have read and understood the manual and observe all safety instructions surrounding use of the engine and machine.



WARNING!

Engine must only be started in open air, never in an enclosed environment.

Diesel Engine Starting

- Observe all Safety Instructions.
- Ensure machine is in the open air and not in an enclosed environment.
- Check fuel level and replenish if required.
- Turn ignition key on the machine clockwise to the first position; LCD shows home screen - *if pre-heat plug light is illuminated wait until light goes out before continuing.*

NOTE: When the ignition key is turned to the first position the machine will perform a sequence of system checks.

- Start engine by a further turn of the ignition key. *Note: It is not possible to 'link' to the remote control when the engine is started by key.*

Linking Remote Control Unit to Machine

To operate the machine remotely the control unit must first be 'linked' to the machine so that command signals can be transmitted and received; the procedure is as follows;

NOTE: Ignition key must be turned to the pre-starting position.

- Turn on the control unit by rotating the Emergency Stop Switch clockwise – *the button will 'spring out' to the ON position.*
- Press and hold the horn button down – *the unit will search for the machine's transmitter and lock onto the signal, the horn will sound to confirm that the units are linked.* Release the horn button as soon as the confirmation sound is received.
- The machine can now be started by operation of the start button on the remote controls (*refer to controls section*), release button as soon as the engine starts.

NOTE: If the engine fails to start within 5 seconds release the button and wait for a minute or so before trying again.

GENERAL CAUTION! Never operate the starter for excessive uninterrupted periods attempting to start an engine as this can damage or burn out the starter motor.

DRIVING & MANOUEVERING THE MACHINE



Operation of the machine must only be performed by a responsible person who has read the manual and is familiar with the machine controls and all aspects relating to its safe use.



It is advisable that all new operators practice using the machine, without the cutting head running, in a safe open area in order to familiarise themselves with the controls and movements of the machine.



Power ON



Emergency STOP



Forwards & Backwards Travel

Operation of the machine's forward and backwards movements are controlled by using the left-hand joystick (A) on the remote controls; push the lever forwards to move the machine forwards, pull the lever backwards to move the machine backwards. The joystick operates proportionally, therefore; the further the lever is moved the faster the machine travels. The maximum speed available will be determined by the selected position of the gear switch (D), refer to gear control for details.

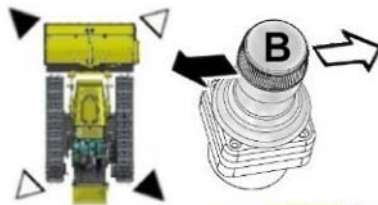
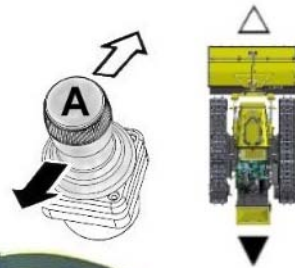

Steering Direction Control

The steering direction of the machine is controlled by sideways operation of the right-hand joystick (B); moving the lever to the right will steer the machine to the right and moving the lever to the left will steer the machine left.

Steering is achieved by adjusting the speed or the turning direction of the tracks in relation to each other; depending on the intensity of the turn one or other track will decelerate, stop or even reverse causing the machine to change direction, the sharpness of the turn is relative to how far the operation lever is moved.

Flail Head (Tool) Height Control

The tool height is controlled by forward and backwards operation of the right-hand joystick (B).

Push the lever forwards to lower the tool.
Pull the lever backwards to raise the tool.

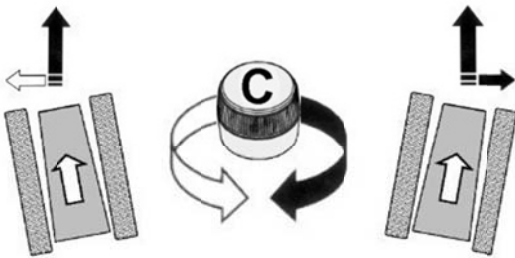
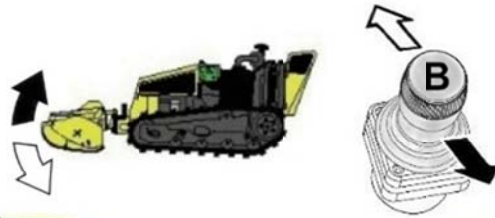

Steering Bias

The steering bias feature allows a degree of 'steer' to be pre-set for operating the machine across slopes, adjustment is made using the bias dial switch (C).

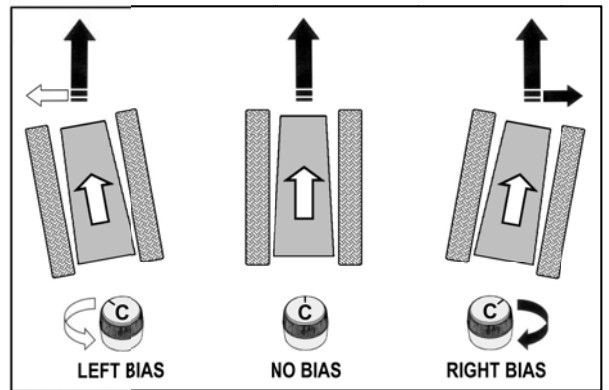

Rotate the dial either clockwise or anti-clockwise for right or left bias respectively; the further the dial is rotated the greater the bias. Although steering will still need to be monitored and operated as normal it will be to a much lesser degree.

Gear Control

The machine has 3 electrical gears to provide a choice of travel speeds; gears are selected using the gear switch (D). The gear speeds are represented on the control panel by a snail for the slowest gear, a tortoise for the intermediate gear and a hare for the fastest gear.

When in work it is recommended that the machine is operated in either the slow or the intermediate gear and speed limited, especially when working the machine on steep slopes. The fast gear is primarily for use when driving the machine between work areas on smooth even terrain where it is safe to use higher speed.

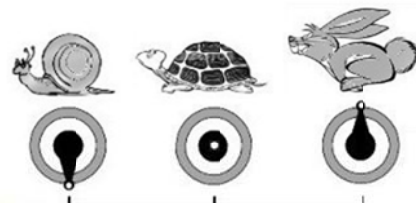



Engine Speed (RPM)

Engine speed is controlled using the engine revs switch (E). Operate the switch upwards to increase engine revs or downwards to reduce the engine revs.

Flail Head Rotor Control

Operation of the rotor is controlled by the rotor switch (F); Move the switch to the up position for uphill cutting or to the down position for downhill cutting - engine revs can be increased according to requirements using the revs switch 'E' as stated above.

Once the rotor is running its speed can be increased or decreased as required by subsequent operations of the rotor switch 'F'.

To stop the rotor move the switch to the opposing direction of cut then wait for the rotor to come to a complete standstill.

Note: in an emergency situation the rotor can be stopped by use of the Emergency Stop button; this will immediately switch off and deactivate all machine functions, including the engine.



Engine Shutdown

Engine Shutdown

Before shutting down the engine all machine movements must be halted, engine revs reduced to minimum and the rotor switched off. Allow the machine to run at this level for about one minute to stabilize pressures and temperatures - shutting down the engine is then performed by pressing the engine shutdown button on the right hand side of the control unit.

When the engine has stopped the procedure is completed by switching off the ignition key on the machine and pressing the Emergency stop switch. If the machine is to be left untended the key should be removed and control unit and key placed in a secure safe location

LCD DISPLAY (CANBUS Unit)

Overview

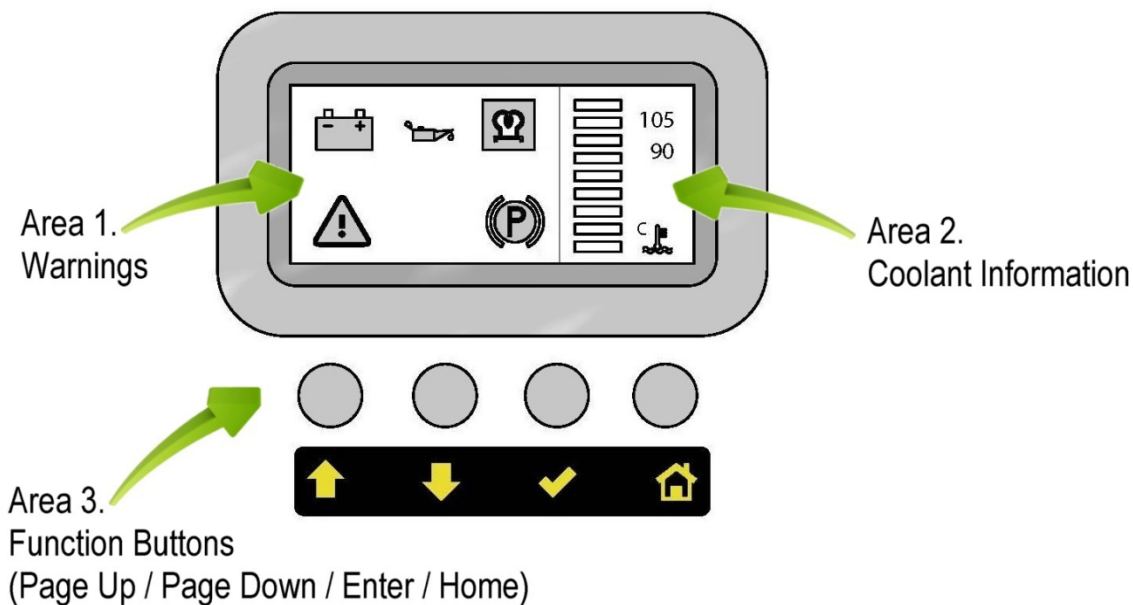

Home Page

With the ignition key inserted and turned to the on position (without starting the engine) the LCD unit will show the home page displaying the following icons;

1. *Battery/Alternator Warning*
2. *Engine Oil Pressure Warning*
3. *Parking Brake Warning*
4. *Engine Stop*
5. *Pre-Heat Plugs (Optional)*

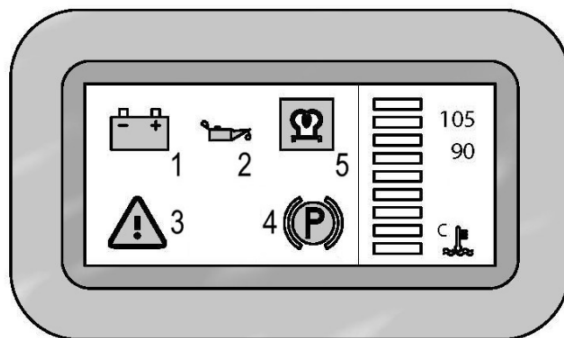

Mechanical Fault Warnings

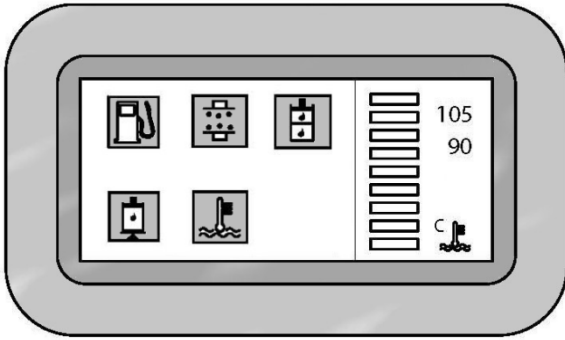

If the machine develops a problem or issue the LCD will display a warning symbol indicating the cause.

The chart below identifies the warning symbols that may be displayed and states machine action, cause, and the remedy required to correct the problem.

Warnings Chart

DASHBOARD		HORN	SHUTDOWN	CAUSE	REMEDY
LED 1		YES	NO	Fuel level less than 1/4.	Add fuel.
LED 2		NO	NO	Parking brake on.	Move machine forwards or backwards to release brake.
LED 3		YES	NO	Hydraulic oil level below 2/3.	Top up hydraulic oil and check system for leaks.
		YES	YES	Hydraulic oil level too low.	Top up hydraulic oil and check system for leaks.
LED 4		NO	NO	Alternator not charging the battery.	Check belt tension correct. Contact Isuzu Service.
LED 5		NO	YES	Air filter clogged.	Change filter element.
LED 6		NO	YES	Hydraulic oil filter clogged.	Change filter element.
LED 7		NO	NO	Pre-heating on (Optional).	Wait until the light goes out before starting engine.
LED 8		NO	YES	Low engine oil pressure.	Check engine oil level, top up if required. Check electrical connection.
LED 9		NO	YES	Engine stop.	Release Emergency Stop Button and check correct LED's are displayed.
LED 10		NO	YES	Coolant temperature >110° C	Clean radiator matrix, check/top up coolant level. Check system for leaks.

Control System Fault Warnings

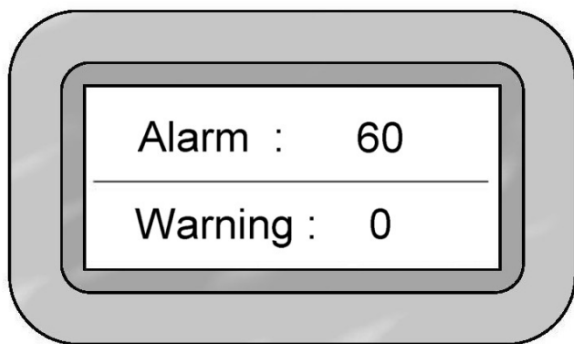

If the control system develops a malfunction the screen will display 'Alarm' followed by a numeric error code to identify the cause of the malfunction.

The chart below identifies specific error codes and control components the faults relates to.

ERROR CODE	CAUSE
Set 4 + number	Fault / Error - Display Error
Set 6 + number	Fault / Error - Radio Communication Error
Set 7 + number	Fault / Error - Remote Control Manipulators
Set 9 + number	Fault / Error – Inclinator
Set 50 + number	Fault / Error – Control Outputs

If the control system reports a fault warning the machine should be stopped immediately and the engine switched off, re-start the machine again to determine if the system fault has cleared. In the event of a persistent fault contact McConnell Service for advice.

Manual Control Unit (Emergency Track Operation only)

A manual control device for track operation is provided with the machine to allow the operator to bypass the Radio Controller in the event of a controller malfunction.

When connected to the machine, this device will allow the operator to raise and lower the flailhead and manoeuvre the mower in any direction.

This feature is primarily for use in an emergency situation to allow transport of the machine in the event of a sudden breakdown or for diagnosing an issue with the controller.

When operated in this mode the machine will only travel at minimum speed and all other control features are deactivated.

To use this control the unit must first be connected to the electronic ignition box, refer to the following page for details.



WARNING!

The manual track control is for emergency situations and troubleshooting purposes only – never attempt to use this feature for normal work operations.

Manual Controller



- A) Forwards left track
- B) Backwards left track
- C) Flailhead (tool) lift
- D) Flailhead (tool) lower
- E) Forwards right track
- F) Backwards right track

Manual Controls Operation

To manoeuvre the machine;

Forward travel is by simultaneous operation of buttons 'A' & 'E'.

Right turn is by operation of button 'A' only.

Left turn is by operation of button 'E' only.

Reverse travel is by simultaneous operation of buttons 'B' & 'F'.

Counter-rotation to the right is by simultaneous operation of buttons 'A' & 'F'.

Counter-rotation to the left is by simultaneous operation of buttons 'B' & 'E'.

Flailhead (tool) lift is by operation of button 'C'.

Flailhead (tool) lower is by operation of button 'D'.

Converting the Machine for use with the Manual Control Unit

The method of adapting the machine for use with the manual control unit requires attachment of the Control Unit and deactivation of the Brake Control Module; the procedures are as follows;

Control Unit Attachment

Connect the manual control unit to its connection point on the electronic ignition box; the connection point is located on the right hand side of the machine as shown in the photos below.



Location of connection point for the Manual Control Unit

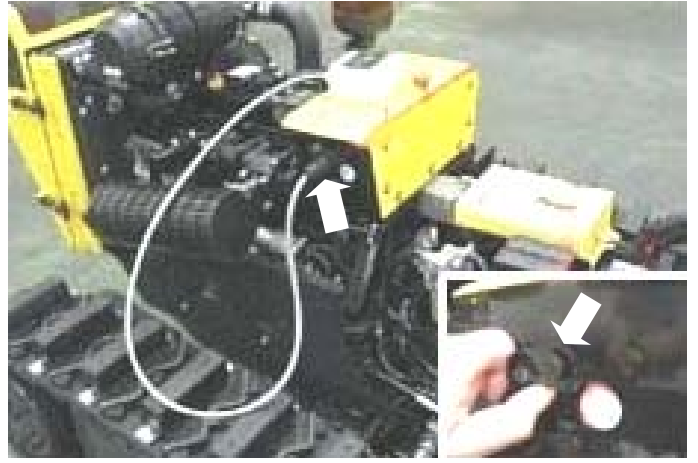

Remove dust cover and plug unit into the connection point

Deactivating the Brake Control Module

Under normal operating conditions when using the remote control, movement of the joystick sends a signal to the brake system instructing it to release the brakes.

When using the manual control unit the brake controller must be bypassed to allow the brakes to release, this is achieved by disconnecting the wiring loom from the brake control module.

The brake control module is located under the bonnet on the right hand side of the machine – indicated 'T' in the photographs opposite and below.



Location of Brake Control Module (T)



Brake Control Module identification (indicated 'T')



Disconnect the wiring loom plug from the Brake Control Module to allow machine operation with Manual Control



Note: Failure to disconnect the Brake Control Module will result in the engine stalling when attempting to transport the machine in Manual Control Mode.

PRE-OPERATION CHECKS



WARNING! All checks or inspections of the machine should be performed with the machine parked on firm level ground with the engine switched off and the starting key removed.

The following checks should be made daily before using the machine;

- Check all safety guarding is in good condition and fitted correctly.
- Check nuts and bolts for tightness, retighten if required.
- Check flail head for damaged or missing flails – replace if required before use.
- Check oil, coolant and fuel levels, replenish if required.
- Check filters – clean or replace if required.
- Check radiator matrix is clean – clear blockages if required using compressed air.
- Lubricate machine as per details stated in the maintenance section.



Work and Work Area Precautions

- Always inspect the work area prior to operations; check for and remove foreign bodies such as large stones, metal component, wire and glass etc. which could damage machine component or be ejected by the flail head. Any immovable object should be visually marked or avoided.
- Ensure the area is clear of animals and persons. Never manoeuvre the machine into an area where you can no longer see it working.
- Only work the machine in grass or brushwood that is within its cutting capability; attempting to cut materials beyond the machines capability will damage components.
- When working on slopes always start at the bottom and work up.
- Never run the machine down a slope in excess of 50°
- Never operate the machine on slopes or ground where there is a risk of overturn.

OPERATION



Always wear safety shoes, ear defenders and safety glasses when operating the machine.



Always work in good lighting conditions. If necessary, use artificial lighting in compliance with local rules in force.



Do not smoke near the machine; oils, fuels and lubricants are flammable.

Before moving the machine, ensure that there are no persons, animals, or obstacles in the work zone.



Do not change direction whilst moving on kerbs, rocks or surfaces with considerable differences in height (*more than 20cm*); in these instances always move perpendicular to the obstacles.



When reversing uphill, do not steer when transferring from the level surface to the slope, if this is unavoidable, perform the manoeuvre gradually.

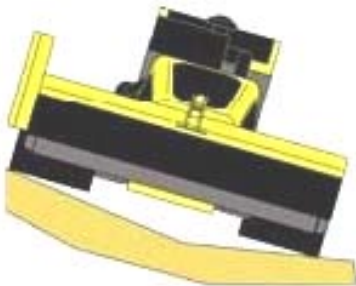

Do not move along the edge of a slope or on uneven ground with one track in the horizontal position and the other inclined or partially raised (*when machine is inclined in excess of 10°*). To avoid risk of track damage, always proceed with both tracks travelling on the same horizontal plane.



When the machine manoeuvres over an obstacle, a space is created between the bearing rollers and the track - this can cause the track to come off its seat. The same situation can occur in reverse when a space is created between bearing roller, idler roller, and track. To eliminate this risk, track guides are provided on the front part of the undercarriage.

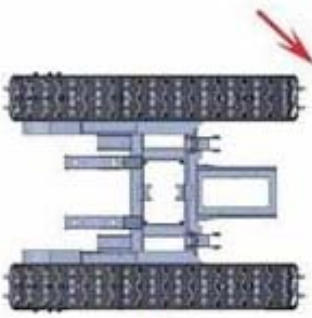

If the machine changes direction, and the track cannot move sideways due to the presence of an obstacle, there is a risk that the track can be damaged or come off its seat; wherever possible avoid turning the machine when it is against an obstacle, if unavoidable, make manoeuvres slowly and gradually until clear of the object.



◀ If the machine moves in reverse in these conditions, there is a risk of the track coming off its seat.

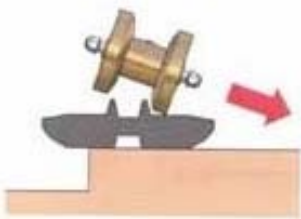

◀ If the machine is steered in these conditions, the track will come off its seat.

MAINTENANCE SECTION

Diesel Engine Maintenance

For specific service and maintenance information regarding the diesel engine, refer to the engine manufacturer's handbook provided with the machine. Ensure all service and maintenance work on the engine is carried out at the intervals stated in that manual.

Maintenance Scheme (General Machine)

Every Hour

Clean air suction filter.

Clean radiator matrix if required using a compressed air line.

Clean air intake area around the oil radiator.

Clean oil radiator.

After Initial 8 Hours - New Machine

Check nuts, bolts, pipes and hoses for tightness – *tighten if required.*

Check track tension and adjust if required – *refer to specific section for details.*

Check hydraulic oil level – *replenish if required.*

Clean radiator matrix – *use compressed air line.*

Daily

Clean radiator using compressed air line.

Check hydraulic oil level – *replenish if required.*

Check engine oil level – *replenish if required.*

Check coolant level – *replenish if required.*

Every 50 Working Hours

Grease carrying rollers and sliding rollers.

Check track tension and adjust if required (*60 Nm max*).

Check flail head belt tension and adjust if required.

**Replace engine oil (*first oil change on new machine).*

After Initial 100 Hours - New Machine

Drain and replace hydraulic oil.

Replace hydraulic oil filter.

Every 250 Working Hours

Replace hydraulic oil filter.

Drain and replace engine oil.

Replace engine oil filter.

Replace fuel filter

Every 500 Working Hours

Drain and replace hydraulic oil.

Replace engine air filter.

Every 1000 Working Hours

Drain and replace engine coolant.

Maintenance Scheme (Track Components)

Daily Checks

Check track tension.

Check condition of gear motors.

Check track condition; *replace tracks when there is less than 10mm of tread remaining or sooner if there are visible signs of deep cuts or cracks.*

Check there are no stones or foreign bodies within the tracks, rollers, gears or sprockets.

Monthly Checks

Check oil level in gear unit.

Check rollers are correctly fastened.

Check there is no slack in the bearings.

Six Monthly Checks

Check wear and tear and overall condition of connections, pinions and lower rollers – *these must be replaced when they reach their maximum wear limit; refer to 'wear limits' page.*

Check brakes are working correctly.

Check all nuts and bolts for tightness.

Periodic Checks

Check brakes and safety warning decals are in good condition.

Make sure the machine is thoroughly cleaned on a regular basis.

Check all fastenings, supports, steel structural parts, welds and pins etc. are in good condition.

Ensure paintwork is kept in good condition.

Lubricate the tracked undercarriage every 20 working hours.

Hydraulic Hoses

Hoses and hydraulic connections should be inspected for signs of wear or damage on a regular basis, damaged or worn components must be replaced immediately. The working life of undamaged hoses is approximately six years, they should be replaced after this period.

Cleaning the Air Filters Grills & Radiator



If the machine is running, reduce to minimum revs and allow engine to run for a further minute before switching off – *remove and pocket the ignition key.*

Clean outside of air suction grills before releasing the rubber hooks and opening the cover. Clean the radiator matrix, inside of the air intake grill and surrounding area using a compressed air line, do not use any tools to clean the radiator that may cause damage to the fins. Close the cover and secure in place with the rubber hooks.

WARNING!



If the engine temperature becomes too high a red temperature warning light on the ignition panel will be illuminated to notify the operator – where this occurs refer to the engine manufacturer's manual.

Checking Hydraulic Oil Level

The procedure for checking and replenishing the machines hydraulic oil is as follows;

- Park the machine on a firm level site.
- Ensure engine is switch off and the key removed and pocketed.
- Release rubber hooks and raise the front engine cover.
- Unscrew the dipstick (located under the filler cap), remove and wipe with a clean rag.
- Replace dipstick without screwing in, then remove again and check the level – *oil level is correct if the oil reaches the marker on the dipstick.*
- If oil level is too low, top up using 'PANOLIN HLP SYNTH 46' oil (*E2019HLPSE46*).
- When oil level is correct, screw the dipstick back in, close and secure the engine cover.

Note: Only use 'PANOLIN HLP SYNTH 46' oil for topping up and oil changes; *failure to use the specified oil will result in a non-compliance of the Warranty.*



Checking Engine Oil Level

The procedure for checking and replenishing the machines engine oil is as follows;

- Park the machine on a firm level site.
- Ensure engine is switched off and the key removed and pocketed.
- Undo the 4 knurled head screws and lower the cover.
- Remove dipstick and wipe with a clean rag.
- Replace dipstick then remove again and check the level – *oil level is correct if the oil reaches the upper marker on the dipstick.*
- If oil level is too low, top up using 'MOBIL SUPER 3000 X1 5W40' fully synthetic oil.
When topping up oil always clean the surrounding area of the filler cap before removal of the cap to avoid the risk of dirt contaminating the oil.
- When oil level is correct, replace dipstick before raising and securing the cover.



Location of engine oil dipstick

Engine Oil Replacement and Filter Change

Oil Capacity: 6.1L without filter
6.6L with filter

Oil Type: MOBIL SUPER 3000 X1 5W40 Fully Synthetic

The procedure for changing the engine oil and filter is as follows;

- Park the machine on a firm level site.
- Remove drain plug and release the oil into a suitable container – *ensure the container used has sufficient capacity for the amount of oil.*

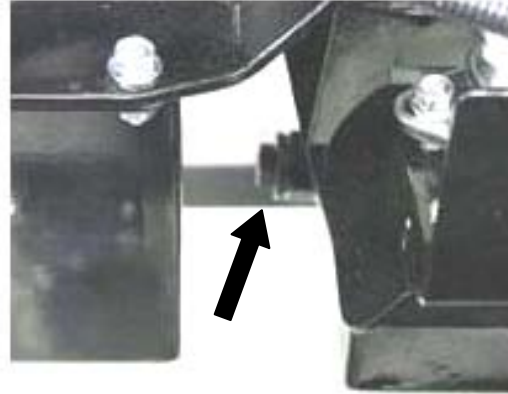

Engine oil drain plug location

- Once all the oil has been released, replace drain plug and torque to 34.5Nm.
- Unscrew and remove the engine oil filter ►



- Take the new filter and smear some engine oil on the rubber seal before fitting – *screw the filter hand tight, then turn it approximately a further $\frac{3}{4}$ of a turn.*
- Remove filler cap and slowly refill with 6.6L of MOBIL SUPER 3000 X1 5W40 engine oil.
- Replace filler cap and start the engine.
- Run engine for 5 minutes or so and stop for a further 3 minutes before checking the oil level is correct.

NOTE: Used engine oil is both a dangerous waste and a precious raw material; collect it in a suitable container and recycle it. Never pour waste oil into drains or waterways – it is harmful and illegal.

Hydraulic Oil Replacement and Filter Change

Hydraulic Oil Tank Capacity: 18 Litres

Complete System Capacity: 28 Litres

The procedure for changing the hydraulic oil and filter is as follows;

- Remove the protection plate from the underside of the hydraulic oil tank.
Note: Removal of the plate allows access to both the hydraulic tank drain plug and the fuel tank drain plug – identify the correct plug before continuing to the next step.

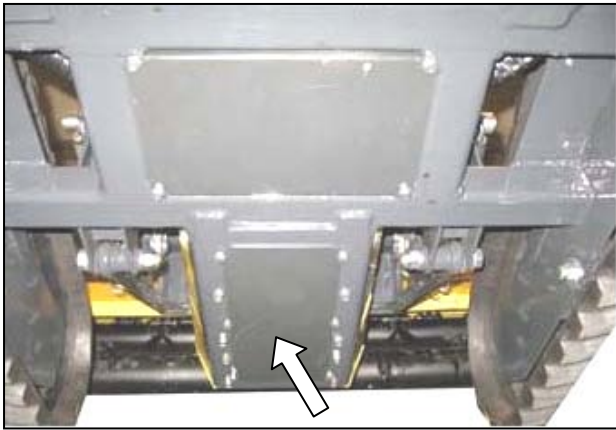

Tank protection plate

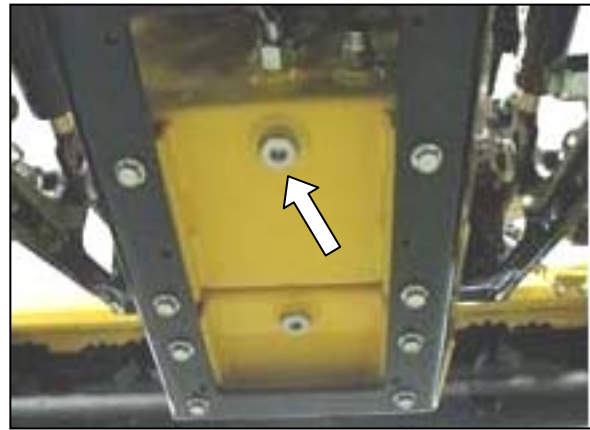

Hydraulic oil tank drain plug

- Remove drain plug and release the oil into a suitable container.
- When the oil has drained completely, replace drain plug and refit protection plate.
- Unscrew and remove the hydraulic oil filter, this is located under the bonnet on the left hand side of the machine – *the filter can be removed by using either a filter wrench or a hexagonal 32mm spanner.*



◀ Hydraulic oil filter location

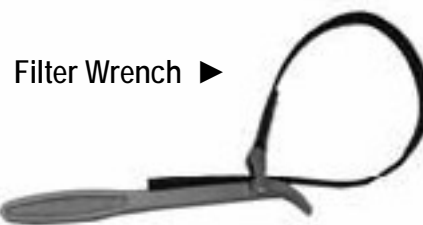

Filter Wrench ▶

- Fit new hydraulic oil filter and tighten securely – take care not to over tighten.
Note: Always replace filters at the intervals stated in the maintenance schedule using quality original filters as specified and supplied by the manufacturer.
- Refill the hydraulic oil tank with 'PANOLIN HLP SYNTH 46' hydraulic oil – check using the dipstick until the level is correct.
- Start engine and allow it to run for 2 minutes.
- Stop engine and re-check oil level on the dipstick, top up if the level has dropped.
- Check all components and covers are tightly secured before using the machine.

NOTE: Used oil is both a dangerous waste and a precious raw material; collect it in a suitable container and recycle it. Never pour waste oil into drains or waterways – it is harmful and illegal.

Hydraulic Distributor Valve

The distributor valve that controls the hydraulic functions of the machine is located under the vehicle and is only accessible from beneath the machine. When working on this, or any other item located under the machine, great care must be adopted to ensure the machine is securely positioned before attempting to access or work on the component.



WARNING: Never attempt to work under any machine that is not safely supported and chocked using suitable equipment specifically designed for the task and capable of supporting its weight.

Access to the valve is gained by removal of the protection plate which is held in position by six bolts.

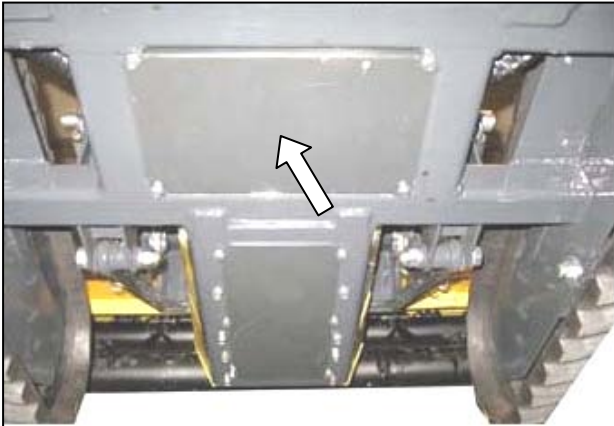

Hydraulic valve protection plate



Hydraulic distributor valve

Fuel Filter Cleaning / Replacement

The procedure for cleaning or renewing the fuel filter is as follows;

Park the machine on a firm level site, switch the engine off and open the engine cover.



Fuel Filter



Fuel Supply Tap

- Close the fuel supply tap located on the filter housing.
- Place a suitable container under the filter assembly and unscrew the filter bowl securing ring using a filter key.
- Carefully remove filter bowl using the container underneath to catch spilled fuel - retain sealing ring for subsequent re-attachment.
- Remove and clean (or renew) the filter element.
- Clean out the inside of the filter bowl using a clean rag.
- Re-install the filter and refit the filter bowl ensuring the sealing ring is fitted.
- Screw the filter bowl securing ring to a point where the sealing ring seats on the housing and tighten further third of a turn.
- Open tap to restore the fuel supply to the filter.
- Unscrew the breather screw on the fuel filter by approximately one turn.
- Place a collecting bowl under the fuel filter.
- Turn ignition key to position 1, this will switch on the electric fuel pump.
- Allow the pump to run until fuel (free of bubbles) begins to flow from the breather screw.
- Screw the breather screw back in.
- Start the engine.
- Check components to ensure there is no fuel leakage.

WARNING: Do not allow the starter motor to run for more than 30 seconds at a time if the engine fails to start – allow at least 2 minutes before re-starting.

Fuel Filter Water Drain

Water will accumulate in the filter bowl that will from time to times need to be purged; the frequency of this task will primarily depend on the quality of the diesel being used. The filter bowl should be regularly inspected, and water drained off as and when required.

The procedure for draining the water is as follows;

- With the engine switched off, place a suitable container under the fuel filter.
- Open the water drain valve located on the base of the filter bowl.
- Allow water to run into the container until it is gradually replaced by a flow of fuel.
- Close the drain valve.



Water Drain Valve

Priming the Fuel System

If at any time the machine runs out of fuel, it will be necessary to prime the fuel system in order to get it running again – the procedure for this is as follows;

- Fill the tank with fuel.
- Unscrew the breather screw on the fuel filter by approximately one turn.
- Place a collecting bowl under the fuel filter.
- Turn ignition key to position 1, this will switch on the electric fuel pump.
- Allow the pump to run until fuel (free of bubbles) begins to flow from the breather screw.
- Screw the breather screw back in.
- Start the engine.

WARNING: Do not allow the starter motor to run for more than 30 seconds at a time if the engine fails to start – allow at least 2 minutes before re-starting.

Support Springs

The hydraulic rams that position the front mounted flailhead are equipped with support springs, the support pressure offered by the springs can be adjusted to suit differing needs and applications by altering their work position tension. The procedure for adjusting the springs is as follows;

- Raise the flailhead fully by operation of the hydraulic rams.
- Remove bolt and washer from the ram rod end and release the chain from the lug.
- Re-attach the chain selecting an alternative link to either increase or decrease tension.
- Replace washer and bolt to secure in position.
- Repeat the process on the opposite ram.



Steel Tracks

Tracks equipped with steel treads can be supplied as an alternative to the normal all rubber type - the steel tread version has the additional option of being fitted with steel spikes.

To fit the spikes remove every second steel tread by removal of the 3 x M8 Allen headed screws, and replace with the steel spike treads using the screws supplied and torque to 70Nm.

If a machine is fitted with spikes the operator must avoid driving the machine on any surfaces that would suffer damage from the spikes such roads, car parks, recreation areas etc. unless the machine has been fitted with rubber transport blocks specifically designed to protect surfaces.



Transport Blocks Fitment

The rubber transport blocks have holes in them that locate on the spikes and are fitted by pushing them onto each set of accessible spikes before slowly driving the machine forward so its weight forces them tightly into place; repeat the process until all the spike sets are fitted with a block. After transportation a lever or large screwdriver will be required to prise the blocks back off the spikes.



Replacing Tracks

Tracks must be changed when only 10mm of tread remains, or sooner if they show signs of excessive cuts or cracks. The procedure for changing the tracks is as follows;

WARNING: Never attempt to work on any machine that is not safely supported and chocked using suitable equipment specifically designed for the task and capable of supporting its weight.



Ensure suitable safety gear is worn at all times when performing maintenance tasks. Beware, there is 'pinch risk' when working on these components.

- Raise the machine off the ground to a height of approximately 30 -40cm; *ensure the machine is stable and suitably supported.*
- Clean undercarriage components and their surrounding area prior to performing maintenance on them.
- Remove tensioner cover (A).
- Loosen locknut and undo screw on the tensioner unit to release the idler roller.
- Remove external pad (B).
- Draw the track down and outwards at its mid point on the lower run to pull it off its seating, levering between the track and the idler roller until it is free enough to be removed. Take care to keep clear of the track as it falls to the ground.

Installing the new track is basically a reversal of the above – tighten the track by adjustment of the screw on the tensioner unit to a setting of 60 Nm and secure with the locknut.

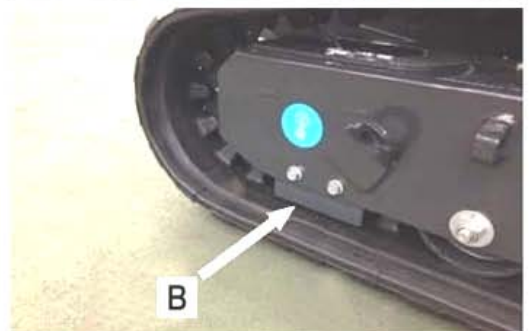
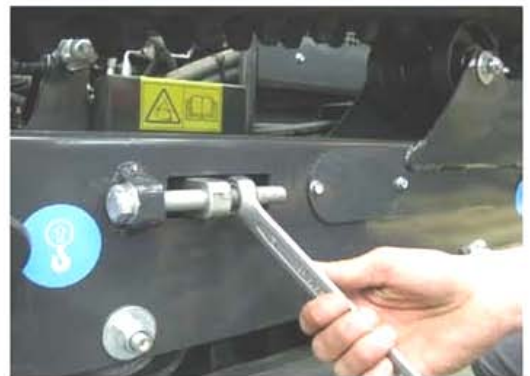

Lubrication of Undercarriage Components

Components of the tracked undercarriage (rollers, pins, bushings etc.), must be greased every 20 working hours.

ELECTRICAL SYSTEM

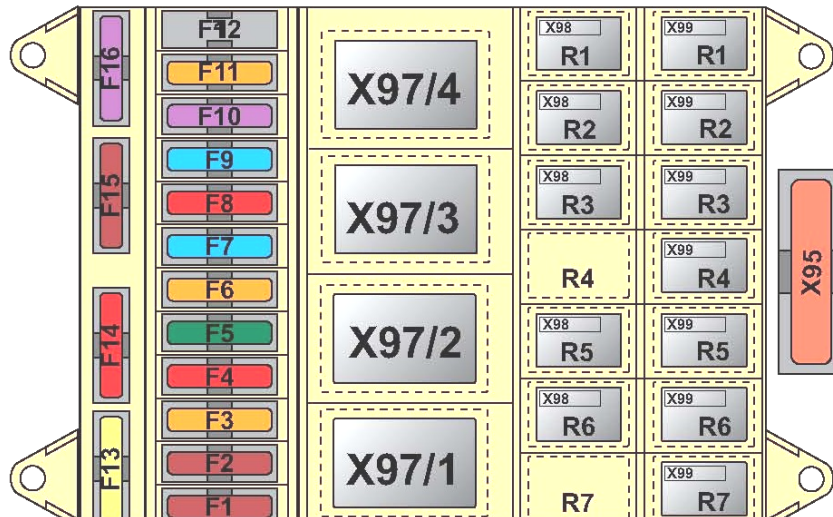

Fuses & Relays

F1	Fuel pump	7,5 Amp
F2	Actuator	7,5 Amp
F3	+15 Controllers & Display	5 Amp
F4	Hold Solenoid + Saftey Stopdown	10 Amp
F5	Pull Solenoid	30 Amp
F6	+15 Warnings Relay	5 Amp
F7	Beacon	15 Amp
F8	Horn	10 Amp
F9	Manual Command	15 Amp
F10	+12V Sensors & Buttons	3 Amp
F11	Alternator	5 Amp
F12	Free	
F13	+30 3B6 Controller	20 Amp
F14	+12V Plug	10 Amp
F15	Receiver Fuse	7,5 Amp
F16	+30 Canview Display	3 Amp
X95	General Fuse	40 Amp

X97/R1	Pull Solenoid relay	X98/R6	Hold solenoid
X97/R2	Air Heater (optional)	X98/R7	Free
X97/R3	Starter relay	X99/R1	Radio-Control stop (Link missing)
X97/R4	Battery switch	X99/R2	Manual control
X98/R1	Actuator +	X99/R3	Beacon lamp
X98/R2	Actuator -	X99/R4	Clean Fix fan (Opt.)
X98/R3	Horn	X99/R5	Check test before start
X98/R4	Free	X99/R6	Engine oil pressure sensor
X98/R5	Lower hyd. oil level	X99/R7	High water engine temp.

Parking Brake Release

During operation or transport, situations may arise when it may be necessary to tow the machine. Before attempting to tow the machine the parking brake must be manually released to reduce the possibility of damage to the drive motor, tracks, or braking systems, and provide safe towing.

The procedure of releasing the brakes requires access to the brake flange plate at the back of the drive motor and utilisation of the following items; a 12mm bolt, a 12mm nut and a support plate with a central hole. The method of release is described below;

WARNING!



Ensure machines tracks are safely and securely chocked before attempting to release the brakes.

Remove the 4 bolts which retain the cover to the drive motor housing using a tool to gain access to the brake assembly on the back of the drive motor.



Pry the rubber dust cover from the brake release access hole.



With a nut and support plate on the 12mm bolt; thread the bolt into the manual brake release hole until it bottoms out in the hole. Move the washer down the shank of the bolt and thread the nut down until it is in firm contact with the metal support plate. Tightening the nut will gradually draw the bolt out and pull the brake plates away releasing the brakes. Turn the nut until it tightens against the plate and will no longer turn. Stop when resistance prevents further movement. **Do not over-tighten the nut.**



Towing

Manually release the braking system before attempting to tow the machine, refer to previous page for details of this procedure.

Suitable towing straps/chains that are rated to a minimum of 2 ton and are free from damage or defects should be used to tow the machine and should be configured as illustrated in the diagram shown opposite.

- A. Towing strap/chain (Min. 2 ton rating).
- B. Link device (Min. 2 ton rating).

Attach these straps/chains to the lifting point positions on each side of the mower. Tow the machine maintaining even pull on each side in a forward direction. Avoid towing the machine from one side or the other as this can risk damaging the tracks and/or track components.

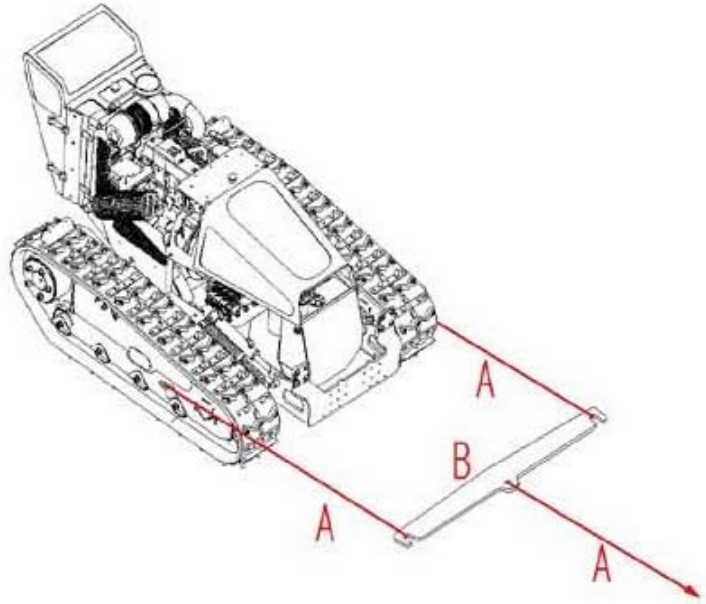

NOTE; Towing of the machine is for emergency situations only and should be avoided if at all possible. For towing on downward inclines suitable rigid towing equipment must be used.

WARNING!



Care must be adopted at all times when towing the machine as there will be no form of braking. Chock tracks to avoid risk of 'freewheeling' and keep all persons clear of the front and rear of the machine when the parking brakes have been manually released.

WARNING!



When towing or lifting the machine the correct attachment points must be used, failure to observe this may result in serious damage or injury to operators and/or bystanders.

Machine Storage

For extended periods of storage it is advisable that the machine be kept in a clean dry environment protected from the elements to avoid risk of corrosion. The temperature of the storage location should not fall below 0° C or rise above 40° C and the machine must not be stored near heat sources, flames or explosives.

The machine should be thoroughly cleaned and lubricated prior to storage. At this point it is good practice to check the machine for worn or damaged components - any parts that require replacing should be ordered and fitted at the earliest opportunity so the machine is fully prepared for the next seasons work.

For security reasons the remote control unit and starting key should be removed and stored in a safe secure location separate from the machine.

TROUBLESHOOTING

Symptom	Possible Cause	Solution
Track damage.	Excessive tread wear; Loosening/breaking of internal structural steel rope.	Replace track.
Track slackens frequently.	Faulty tensioner valve. Damaged tensioner seal. Worn tensioner components.	Replace valve. Replace seal. Replace worn components.
Upper track does not stay in position.	Track slide worn. Upper roller worn.	Replace slide. Replace upper roller.
Lower track does not stay in position.	Lower track guide worn. Lower roller worn.	Replace lower track guide. Replace lower roller.
Track 'jams' when the machine is steering.	Material (stones, rocks, earth etc.) trapped between rollers, sprockets, idler roller and track.	Remove material by turning the track in both directions while slackening slightly, raise machine at same time if possible.
Oil leakage	Hardened seals. Gasket/seals damaged or worn.	Clean around component and recheck after a few days. Contact dealer.
Excessive noise.	Internal malfunction. Worn seals.	Contact dealer.
Excessive vibration.	Internal malfunction. Worn seals.	Contact dealer.
Overheating	Lack of oil. Arduous conditions/hot climate. Brakes binding.	Add oil. Contact dealer. Check brake release pressure.
Motor runs but gear unit not working.	Motor wrongly assembled. Internal malfunction. Brake jammed.	Check coupling between motor and gear unit. Contact dealer. Check braking system.
Brake not releasing.	Lack of brake pressure. Faulty brake seals.	Check brake connections. Contact dealer.
Brakes not locking.	Residual pressure in circuit. Worn brake components.	Check hydraulic system. Contact dealer.

TORQUE SETTINGS FOR FASTENERS

The Chart below lists the correct tightening torque for fasteners. The Chart should be referred to when tightening or replacing bolts in order to determine the grade of bolt and the correct torque unless specific torque values are assigned in the text of the manual.

Recommended torque is quoted in Foot-Pounds and Newton-Metres within this manual. The equation for conversion is 1 Nm. = 1.356 ft. lbs.

TORQUE VALUES FOR IMPERIAL BOLTS

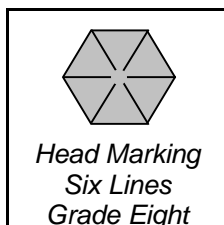
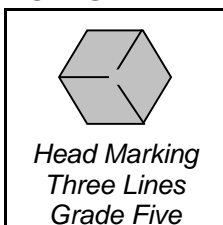
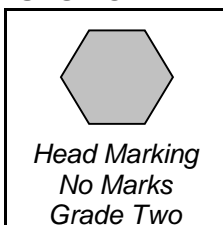
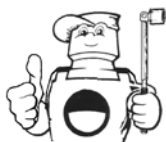

NOTE:
The values in the chart apply to fasteners as received from the supplier, dry or when lubricated with normal engine oil. They DO NOT apply if special graphited, molydisulphide greases, or other extreme pressure lubricants are used. This applies to both UNF and UNC coarse threads.

Bolt Dia.
1/4"
5/16"
3/8"
7/16"
1/2"
9/16"
5/8"
3/4"
7/8"
1"
1-1/8"
1-1/4"
1-3/8"
1-1/2"

Value (Dry)	
ft.lb.	Nm.
5.5	7.5
11	15.0
20	27.0
32	43.0
50	68.0
70	95.0
100	135.0
175	240.0
175	240.0
270	360.0
375	510.0
530	720.0
700	950.0
930	1250.0

Value (Dry)	
ft.lb.	Nm.
9	12.2
18	25.0
33	45.0
52	70.0
80	110.0
115	155.0
160	220.0
280	380.0
450	610.0
675	915.0
850	115.0
1200	1626.0
1550	2100.0
2100	2850.0

Value (Dry)	
ft.lb.	Nm.
12.5	17.0
26	35.2
46	63.0
75	100.0
115	155.0
160	220.0
225	305.0
400	540.0
650	880.0
975	1325.0
1350	1830.0
1950	2650.0
2550	3460.0
3350	4550.0

TORQUE VALUES FOR METRIC BOLTS.

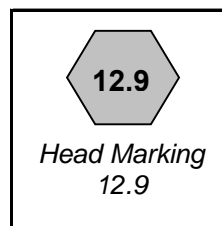
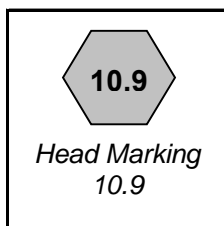
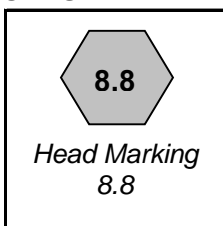
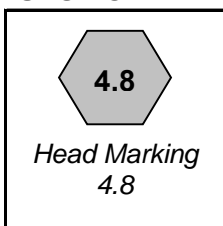

Bolt Dia.
6mm
8mm
10mm
12mm
14mm
16mm
18mm
20mm
22mm
24mm
27mm
30mm

Value (Dry)	
ft.lb.	Nm.
4.5	6.1
11	14.9
21	28.5
37	50.2
60	81.4
92	125.0
125	170.0
180	245.0
250	340.0
310	420.0
450	610.0
625	850.0

Value (Dry)	
ft.lb.	Nm.
8.5	11.5
20	27.1
40	54.2
70	95.0
110	150.0
175	240.0
250	340.0
350	475.0
475	645.0
600	810.0
875	1180.0
1200	1626.0

Value (Dry)	
ft.lb.	Nm.
12	16.3
30	40.1
60	81.4
105	140.0
165	225.0
255	350.0
350	475.0
500	675.0
675	915.0
850	1150.0
1250	1700.0
1700	2300.0

Value (Dry)	
ft.lb.	Nm.
14.5	20.0
35	47.5
70	95.0
120	160.0
190	260.0
300	400.0
410	550.0
580	790.0
800	1090.0
1000	1350.0
1500	2000.0
2000	2700.0

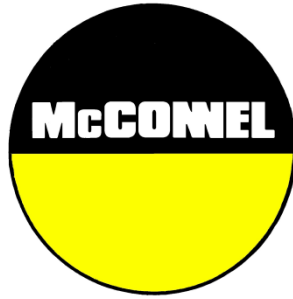

ROBOCUT
'PURE'
- Parts Section -

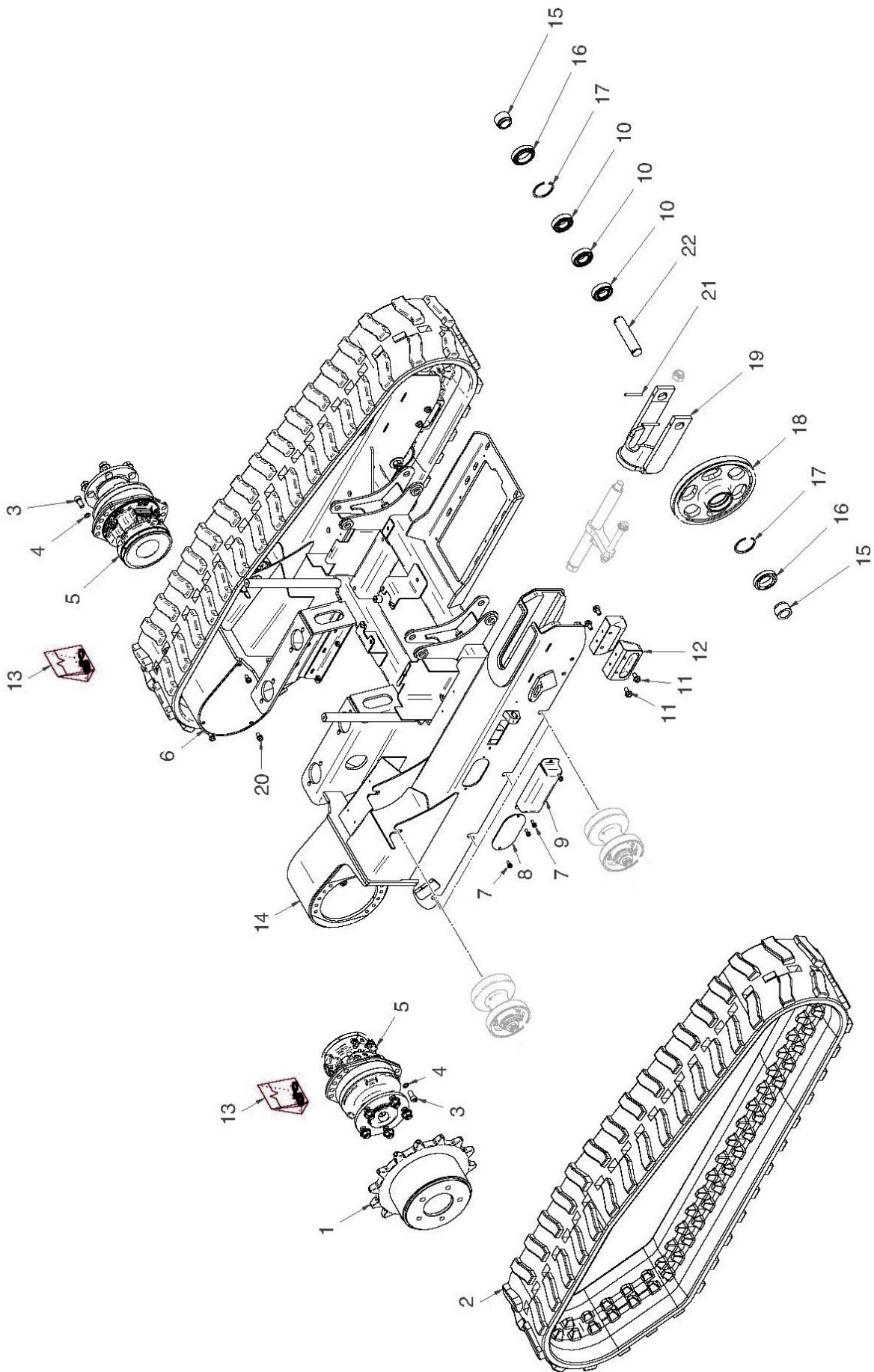

REF.	QTY.	PART No.	DESCRIPTION
			CHASSIS ASSEMBLY
1	2	4000006	SPROCKET
2	2	4000263	RUBBER TRACK
3	20	4000352	SCREW
4	20	4000357	KNURLED WASHER
5	2	4000774	WHEEL MOTOR
6	2	4000007	MOTOR COVER
7	8	4000316	SCREW
8	2	4000011	COVER
9	2	4000775	TENSIONER COVER
10	6	4000776	BEARING
11	8	4000442	SCREW
12	4	4000744	TRACK BLOCKING
13	2	4000777	SEAL KIT
14	1	4000039	UNDER CARRIAGE
15	4	4000010	BUSH
16	4	4000778	SEAL
17	4	4000024	CIRCLIP
18	2	4000779	FRONT SPROCKET
19	2	4000004	SPROCKET FORK
20	8	4000353	SCREW
21	4	4000032	ROLL PIN
22	2	4000009	PIN

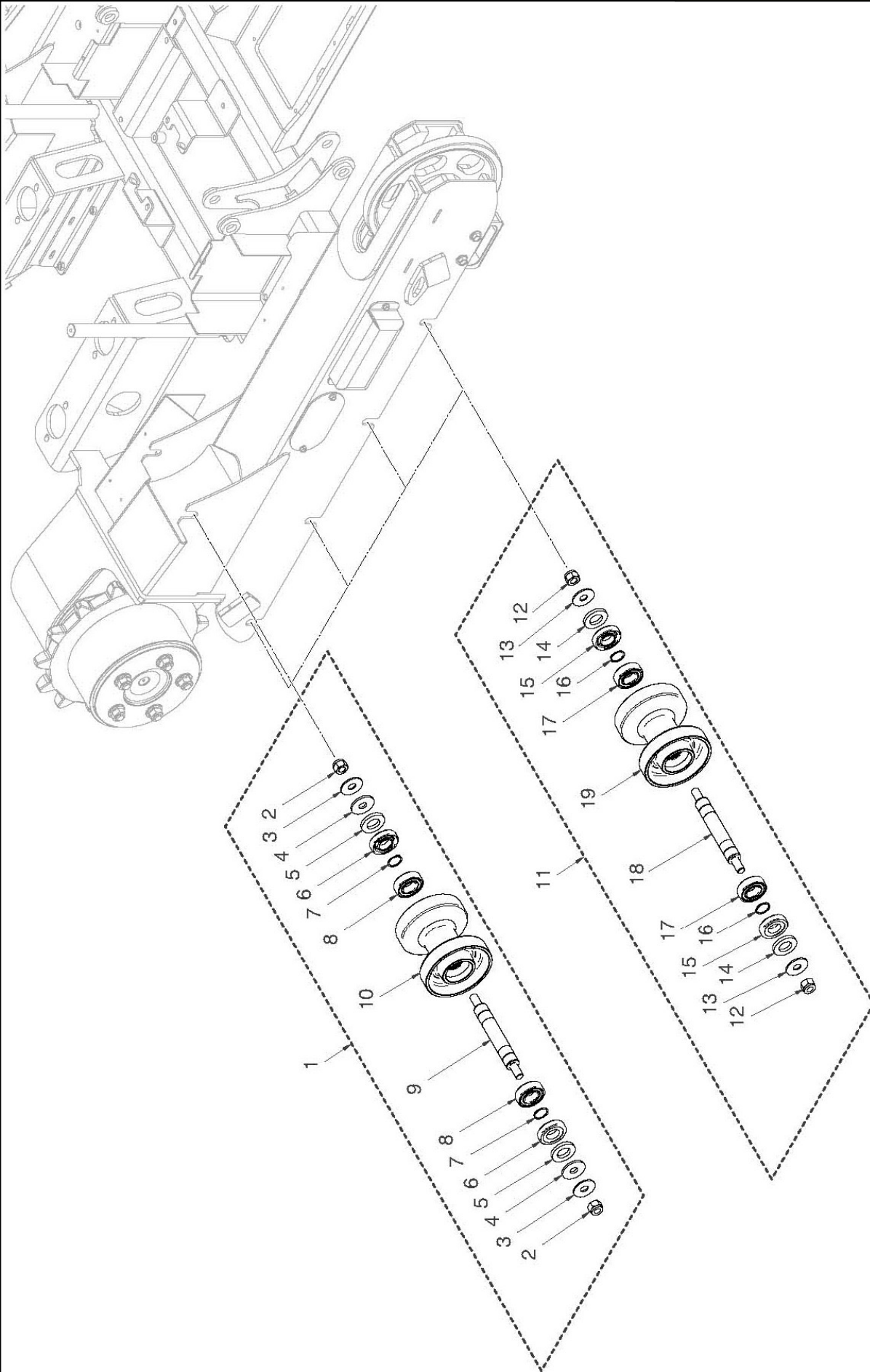

REF.	QTY.	PART No.	DESCRIPTION
			UPPER & LOWER ROLLER ASSEMBLIES
1	2	4000362	UPPER ROLLER ASSEMBLY - <i>comprising of;</i>
2	2	4000355	LOCK NUT
3	2	4000019	WASHER
4	2	4000361	WASHER
5	2	4000351	ROLLER WASHER
6	2	4000780	SEAL
7	2	4000023	CIRCLIP
8	2	4000781	BEARING
9	1	4000015	PIN
10	1	4000016	ROLLER
11	8	4000705	LOWER ROLLER ASSEMBLY - <i>comprising of;</i>
12	2	4000355	LOCK NUT
13	2	4000019	WASHER
14	2	4000351	ROLLER WASHER
15	2	4000780	SEAL
16	2	4000023	CIRCLIP
17	2	4000781	BEARING
18	1	4000015	PIN
19	1	4000016	ROLLER

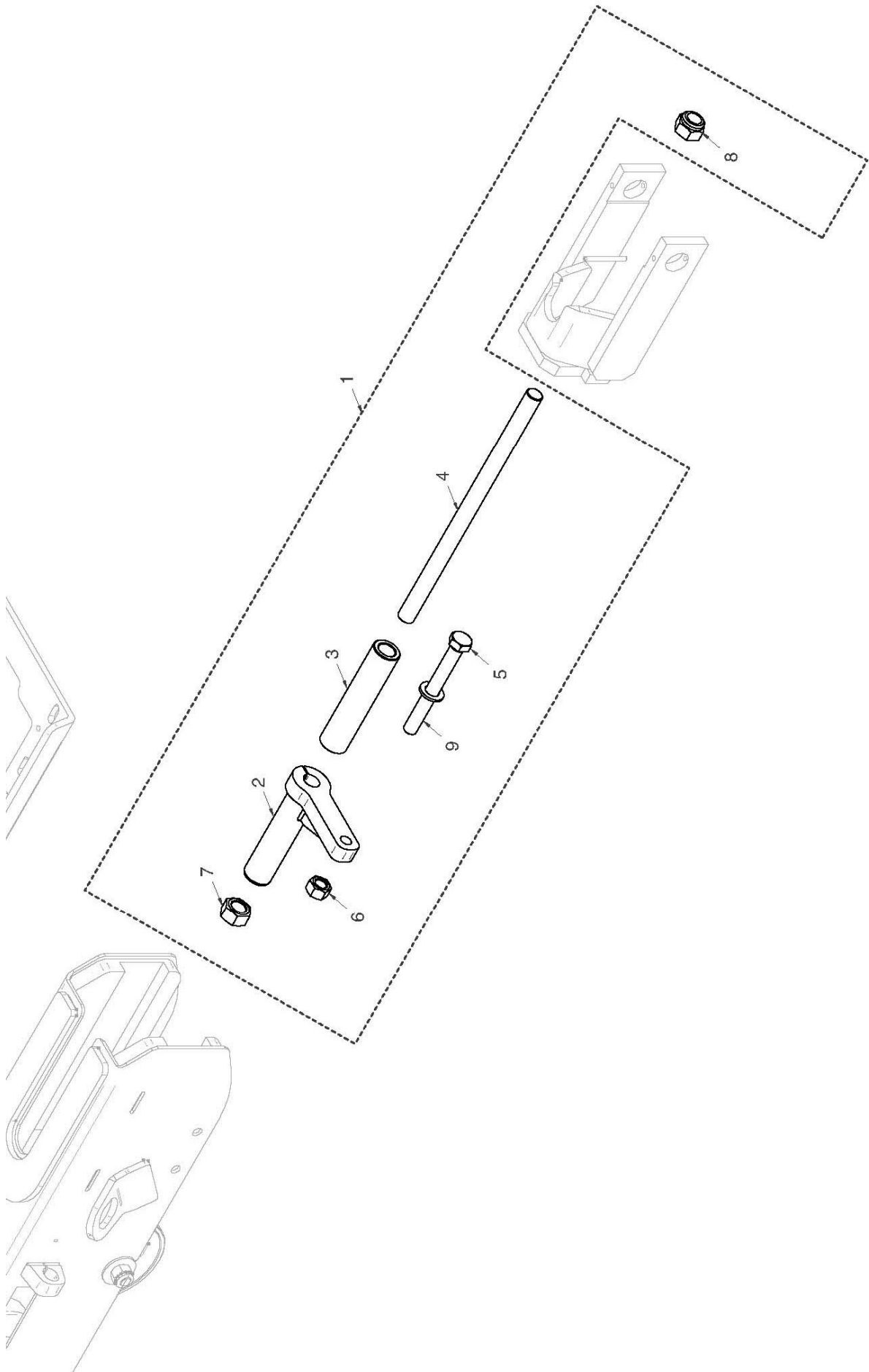

REF.	QTY.	PART No.	DESCRIPTION
			TENSIONER KIT
1	2	4000782	TENSIONER KIT - <i>comprising of;</i>
2	1	4000783	TENSIONER LEVER
3	1	4000784	FORK SPACER
4	1	4000785	TENSIONER
5	1	4000786	SCREW
6	1	4000787	NUT
7	1	4000788	NUT
8	1	4000018	LOCK NUT
9	1	4000253	WASHER

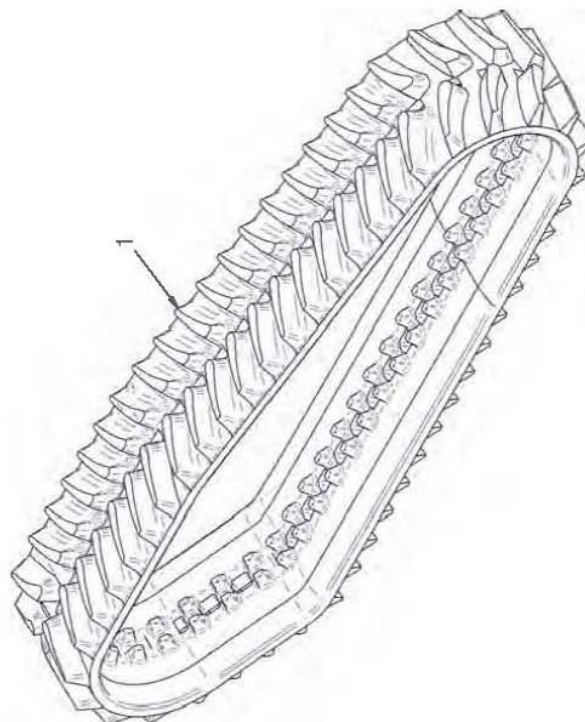
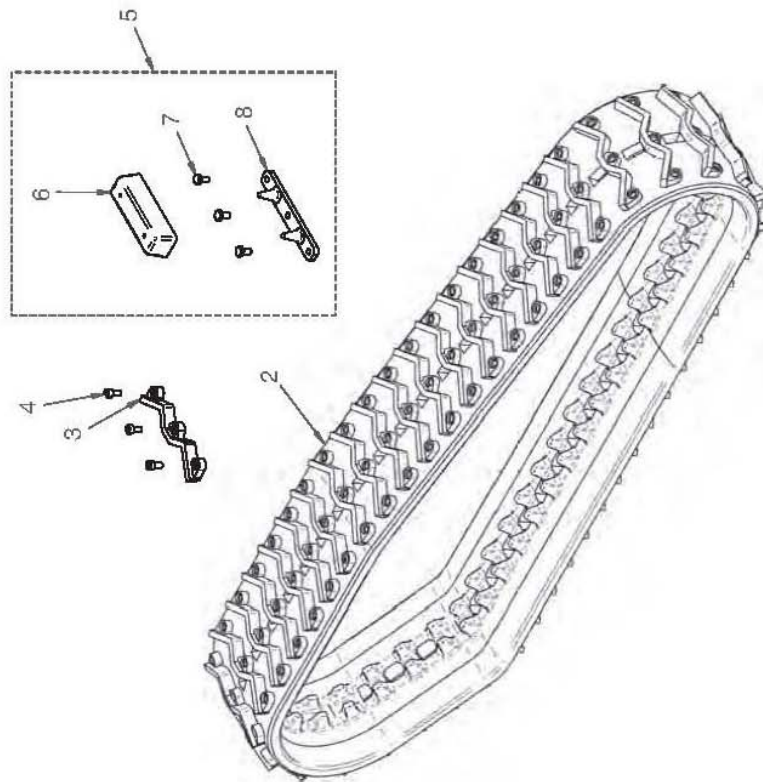

REF.	QTY.	PART No.	DESCRIPTION
			TRACKS
1	2	4000289	* RUBBER TRACK
2	2	4000290	* RUBBER TRACK WITH STEEL STIRRUPS
3	94	4000035	STEEL STIRRUP (<i>for track 4000290</i>)
4	282	4000037	SCREW (<i>for stirrup 4000035</i>)
5	1	4000264	RIVETED STIRRUPS KIT - <i>comprising of;</i>
6	1	4000036	RUBBER TRANSPORT BLOCK (<i>x23 per track</i>)
7	3	4000038	SCREW (<i>x69 per track</i>)
8	1	4000034	TRACK SPIKES (<i>x23 per track</i>)

* *Option*

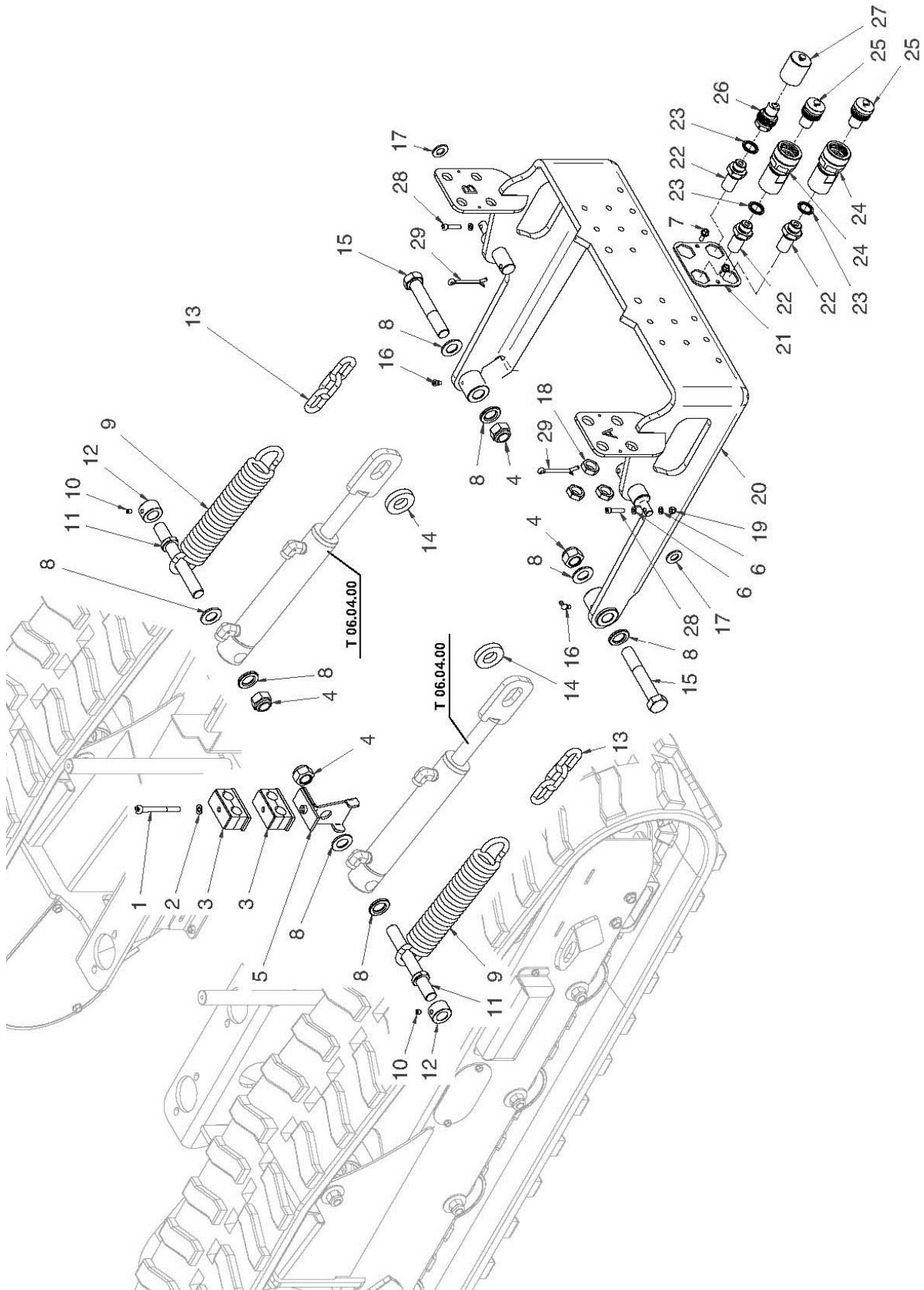

REF.	QTY.	PART No.	DESCRIPTION
			EQUIPMENT MOUNTING ASSEMBLY
1	1	4000365	SCREW
2	1	4000078	WASHER
3	2	4000366	DOUBLE HOSE CLAMP
4	4	4000018	LOCK NUT
5	1	4000363	HOSE SUPPORT BRACKET RH
6	4	4000789	WASHER
7	2	4000316	SCREW
8	8	4000370	WASHER
9	2	4000110	SPRING
10	2	4000369	SETSCREW
11	2	4000089	PIN
12	2	4000090	RETAINING COLLAR
13	2	4000095	CHAIN
14	2	4000091	WASHER
15	2	4000373	SCREW
16	2	4000371	GREASE NIPPLE
17	2	4000790	WASHER
18	3	4000131	NUT
19	2	4000791	LOCK NUT
20	1	4000088	MOUNTING FRAME
21	1	4000093	BULKHEAD FIXING PLATE RH
22	3	4000129	FITTING
23	3	4000792	BONDED SEAL
24	2	4000133	QUICK RELEASE COUPLING
25	2	4000139	PLUG
26	1	4000134	QUICK RELEASE COUPLING
27	1	4000137	PLUG
28	2	4000793	SCREW
29	2	4000794	SPLIT PIN

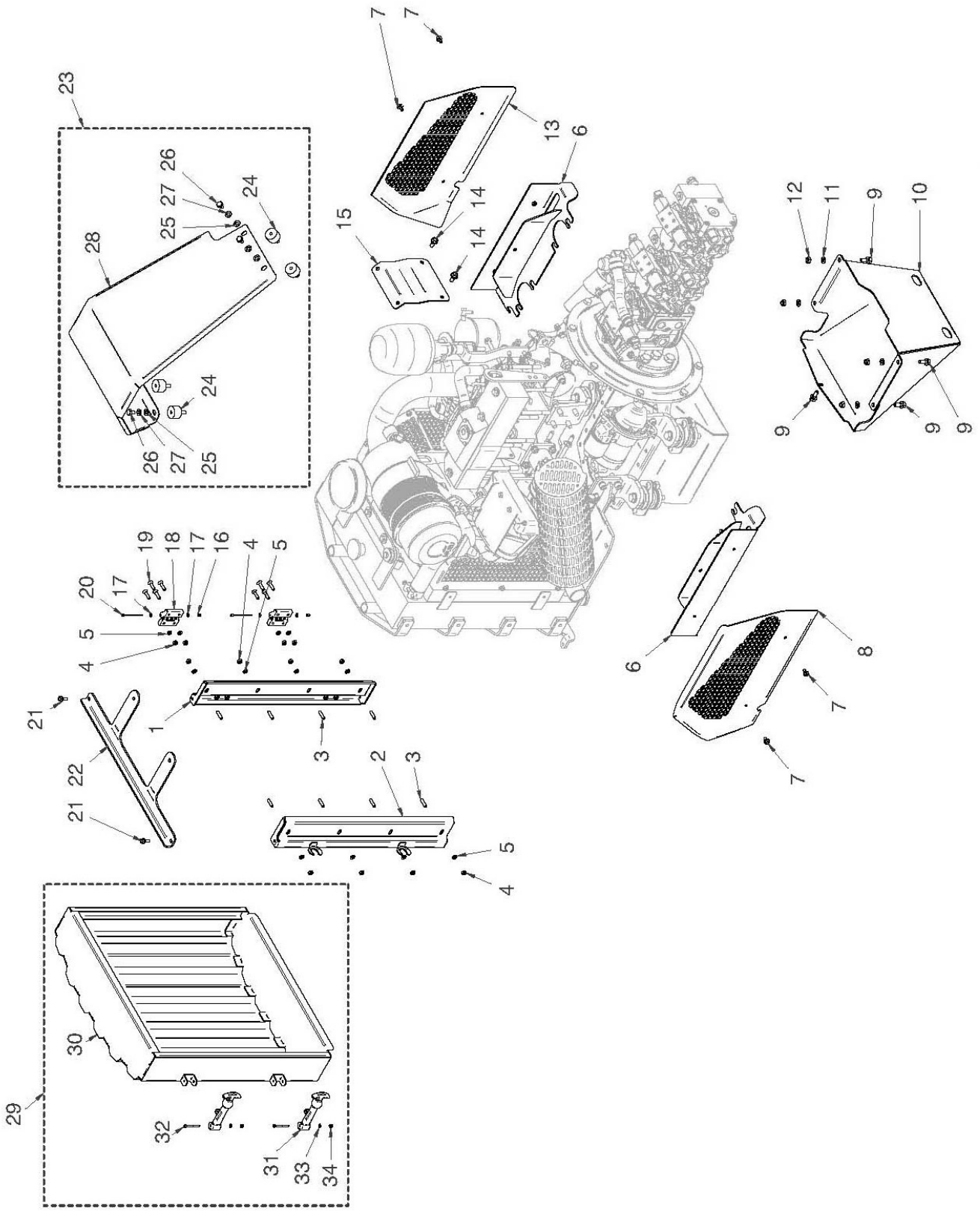

REF.	QTY.	PART No.	DESCRIPTION
			ENGINE COVERS ASSEMBLY
1	1	4000169	RADIATOR LEFT SUPPORT
2	1	4000170	RADIATOR RIGHT SUPPORT
3	8	4000176	SCREW
4	12	4000075	NUT
5	12	4000789	WASHER
6	2	4000375	SIDE PROTECTION SUPPORT
7	4	4000379	SCREW
8	1	4000164	RIGHT SIDE BONNET
9	5	4000380	SCREW
10	1	4000172	REAR COVER
11	4	4000078	WASHER
12	4	4000381	NUT
13	1	4000165	LEFT SIDE BONNET
14	2	4000353	SCREW
15	1	4000167	AIR FILTER BONNET SUPPORT
16	2	9163001	LOCK NUT
17	4	9100101	WASHER
18	2	4000383	HINGE
19	8	4000378	SCREW
20	2	4000377	SCREW
21	2	4000316	SCREW
22	1	4000171	RADIATOR SUPPORT EDGE
23	1	4000795	AIR FILTER BONNET ASSEMBLY - <i>comprising of;</i>
24	4	4000609	ANTI-VIBRATION BLOCK
25	4	4000078	WASHER
26	4	4000376	SCREW
27	4	7315559	WASHER
28	1	4000166	AIR FILTER BONNET
29	1	4000796	RADIATOR BONNET ASSEMBLY - <i>comprising of;</i>
30	1	4000797	RADIATOR BONNET
31	2	4000112	BONNET FASTENER
32	2	4000107	SCREW
33	2	4000798	WASHER
34	2	4000799	LOCK NUT

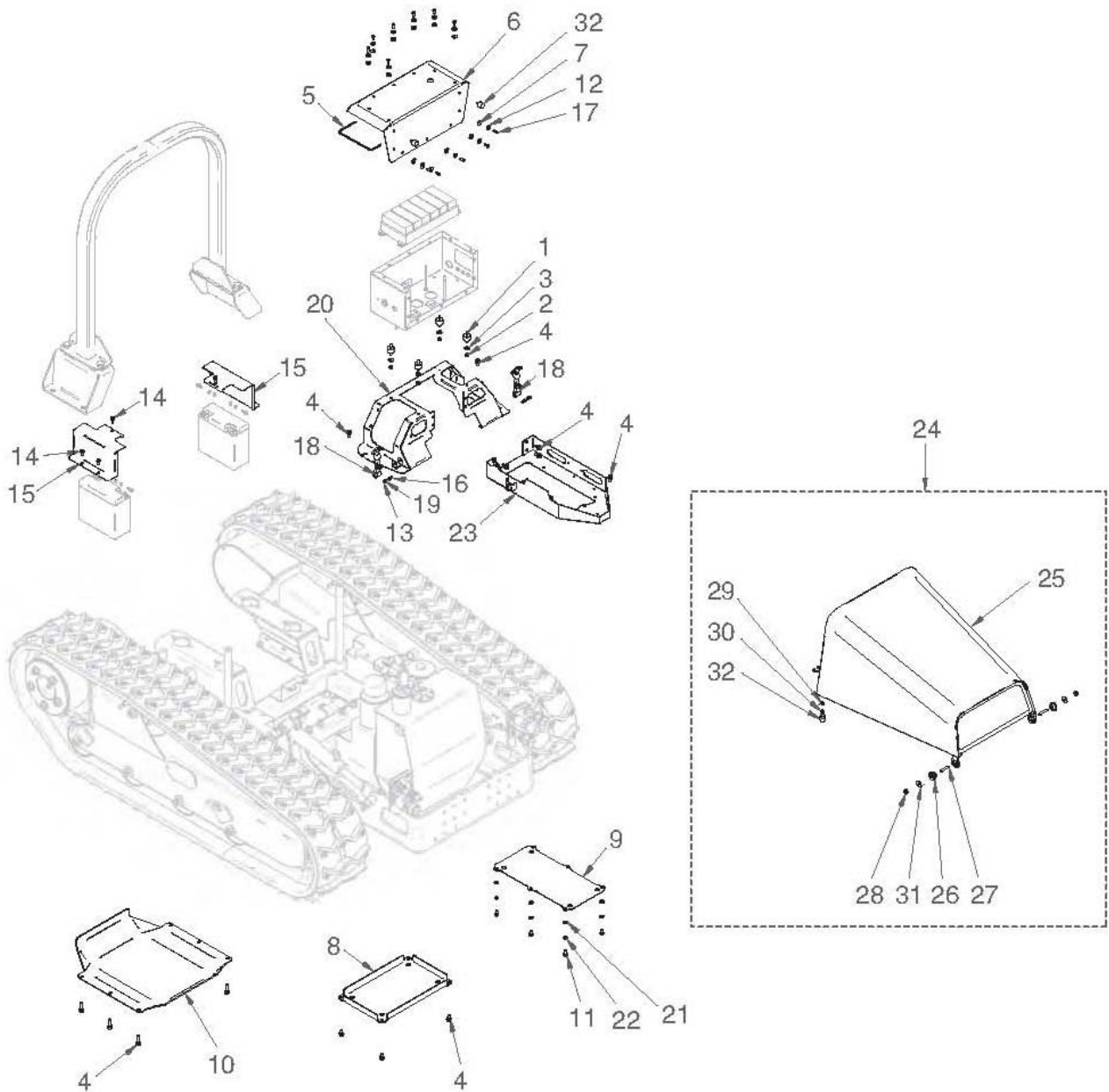

REF.	QTY.	PART No.	DESCRIPTION
			MACHINE COVERS ASSEMBLY
1	4	4000386	ANTI-VIBRATION BLOCK
2	4	4000791	LOCK NUT
3	4	4000321	WASHER
4	17	4000353	SCREW
5	1	4000800	GASKET
6	1	4000801	ELECTRICAL BOX COVER
7	12	4000388	RUBBER WASHER
8	1	4000161	VALVE COVER
9	1	4000162	TANK COVER PLATE
10	1	4000168	SUMP COVER
11	6	4000376	SCREW
12	16	4000321	WASHER
13	2	4000107	SCREW
14	6	4000316	SCREW
15	2	4000153	BATTERY COVER
16	2	4000799	LOCK NUT
17	12	4000387	SCREW
18	2	4000112	BONNET FASTENER
19	4	4000798	WASHER
20	1	4000098	ELECTRIC BOX SUPPORT
21	6	4000078	WASHER
22	6	7315559	WASHER
23	1	4000099	REMOTE RECEIVER MOUNTING
24	1	4000803	UPPER BONNET ASSEMBLY - <i>comprising of;</i>
25	1	4000804	UPPER BONNET
26	2	4000163	BUSHING
27	2	4000384	SCREW
28	2	4000381	NUT
29	2	4000075	NUT
30	2	4000789	WASHER
31	2	4000385	WASHER
32	4	4000251	ANTI-VIBRATION BLOCK

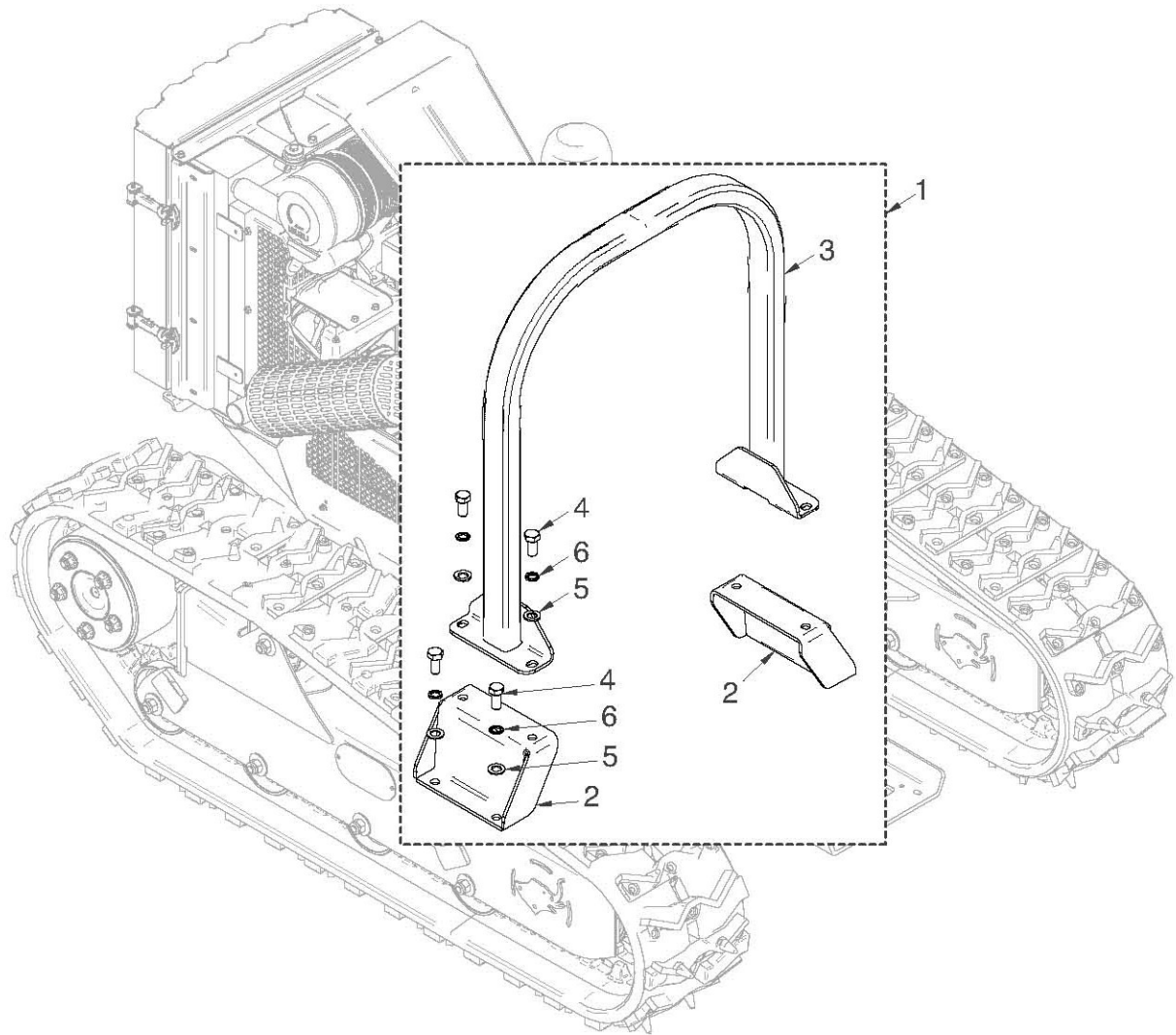

REF.	QTY.	PART No.	DESCRIPTION
			ROLL BAR ASSEMBLY
1	1	4000805	ROLL BAR KIT - <i>comprising of;</i>
2	2	4000151	ROLL BAR BRACKET
3	1	4000152	ROLL BAR
4	8	4000175	SCREW
5	8	4000253	WASHER
6	8	4000610	WASHER

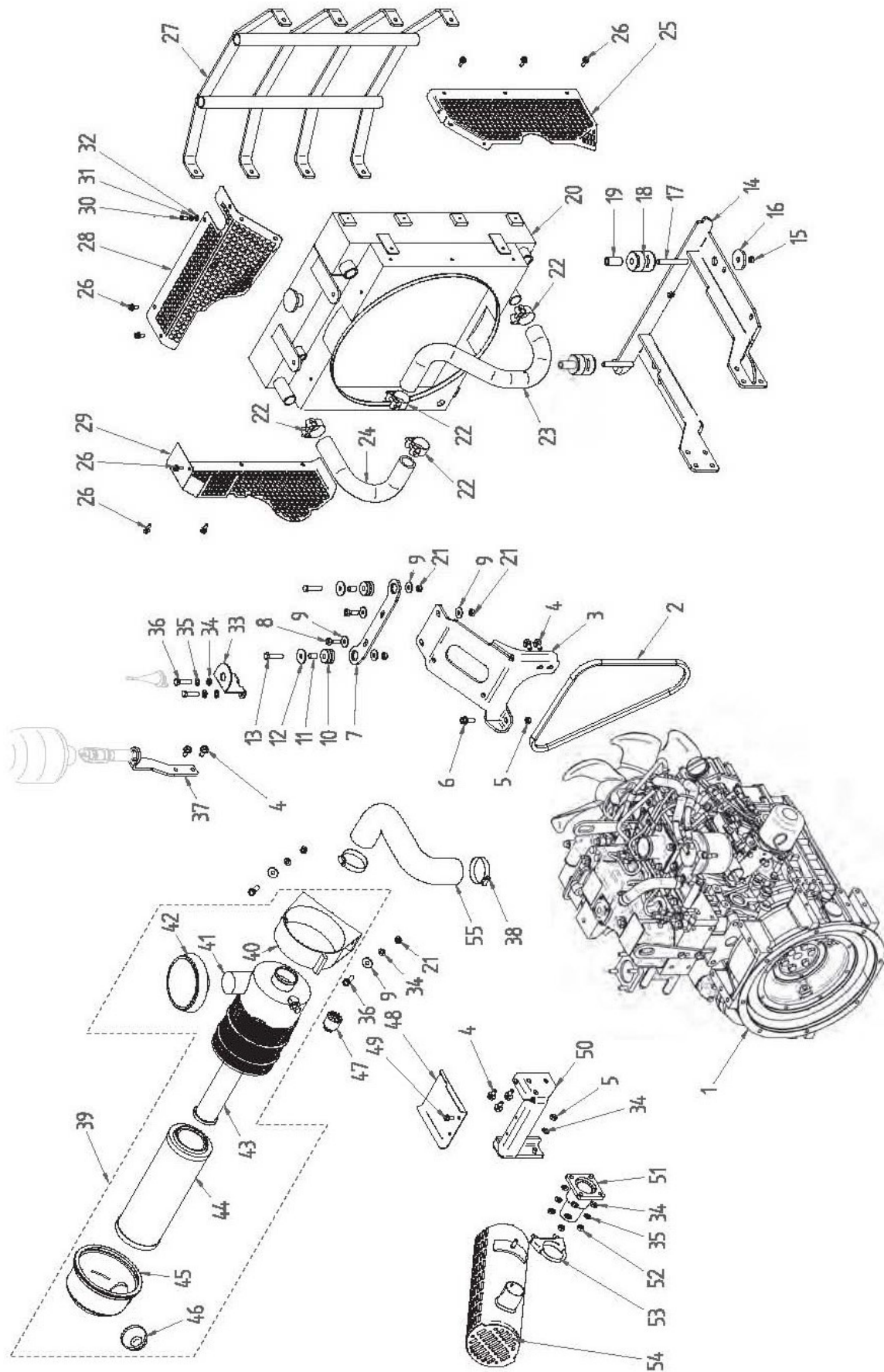

REF.	QTY.	PART No.	DESCRIPTION
			DIESEL ENGINE ASSEMBLY
1	1	4000701	ENGINE
2	1	4000275	BELT
3	1	4000054	AIR FILTER SUPPORT
4	7	4000353	SCREW
5	2	4000381	NUT
6	1	4000380	SCREW
7	1	4000055	RADIATOR BRACKET
8	2	4000806	SCREW
9	8	4000385	WASHER
10	2	4000084	ANTI-VIBRATION WASHER
11	2	4000389	SPACER
12	2	4000080	WASHER
13	2	4000807	SCREW
14	1	4000045	RADIATOR SUPPORT
15	2	4000416	NUT
16	2	4000390	WASHER
17	2	4000068	SCREW
18	4	4000083	ANTI-VIBRATION MOUNTING
19	2	4000391	SPACER
20	1	4000046	RADIATOR
21	6	4000808	LOCK NUT
22	4	4000607	HEAVY DUTY CLIP
23	1	4000392	RADIATOR HOSE (LEFT)
24	1	4000393	RADIATOR HOSE (RIGHT)
25	1	4000041	LEFT MESH GUARD
26	11	4000394	SCREW
27	1	4000047	RADIATOR PROTECTION
28	1	4000043	UPPER MESH GUARD
29	1	4000042	RIGHT MESH GUARD
30	1	4000395	SCREW
31	1	4000544	WASHER
32	1	4000789	WASHER
33	1	4000396	ANTENNA BRACKET
34	9	4000078	WASHER
35	6	7315559	WASHER
36	4	4000809	SCREW
37	1	4000286	LIGHT BRACKET
38	2	4000397	CLIP

Continued...

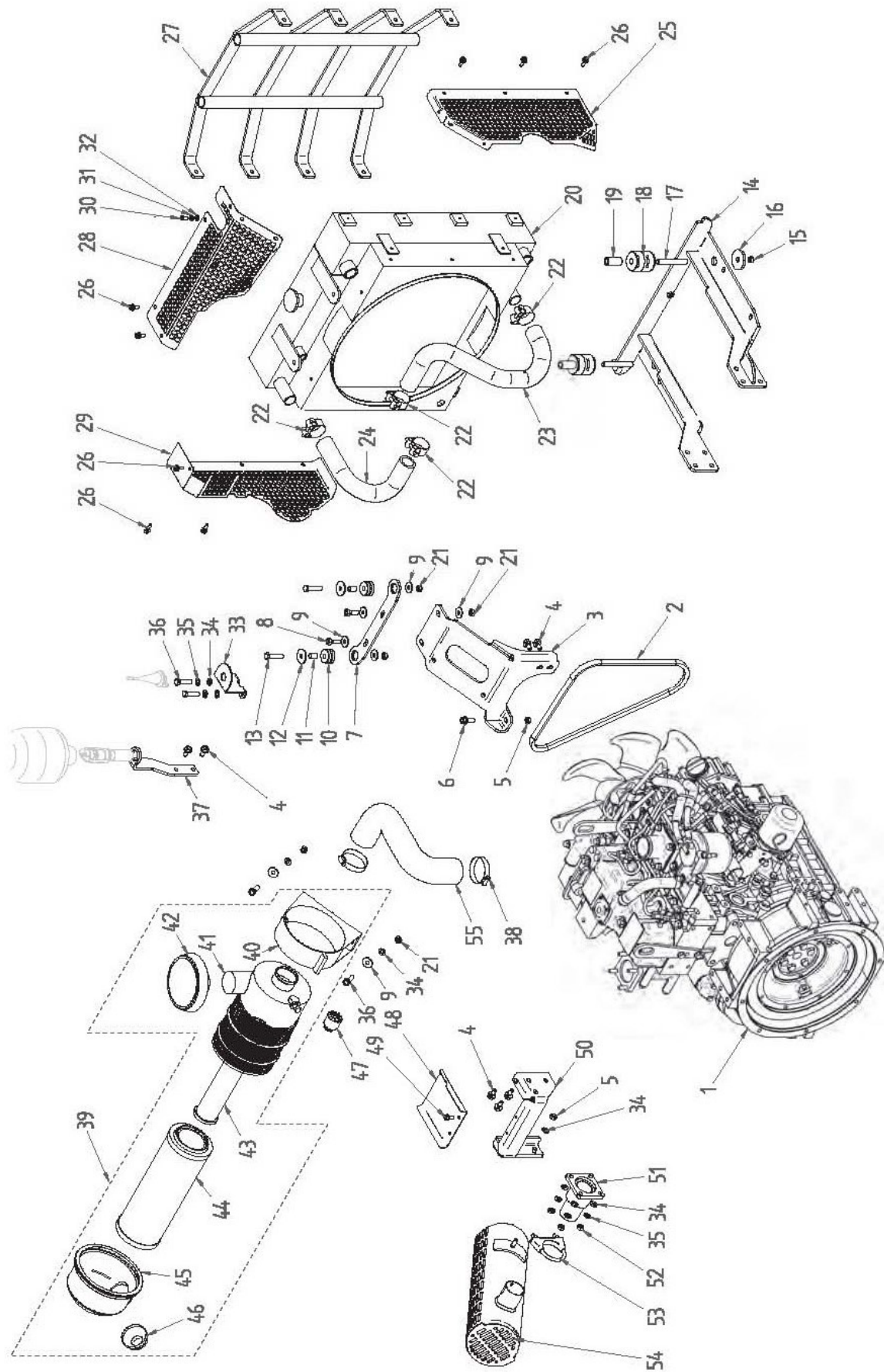

REF.	QTY.	PART No.	DESCRIPTION
			DIESEL ENGINE ASSEMBLY
39	1	4000400	AIR FILTER ASSEMBLY - <i>comprising of;</i>
40	1	4000052	AIR FILTER BRACKET
41	1	4000048	AIR FILTER HOUSING
42	1	4000051	AIR FILTER COVER
43	1	4000261	SECONDARY AIR FILTER
44	1	4000260	PRIMARY AIR FILTER
45	1	4000280	FILTER HOUSING CAP
46	1	4000279	RUBBER VALVE
47	1	4000281	CLOGGING SENSOR
48	1	4000063	ALTERNATOR LID
49	2	4000810	SCREW
50	1	4000062	EXHAUST SUPPORT
51	1	4000061	EXHAUST MANIFOLD
52	4	4000811	NUT
53	1	4000399	EXHAUST CLIP
54	1	4000065	EXHAUST SILENCER
55	1	4000398	RUBBER HOSE

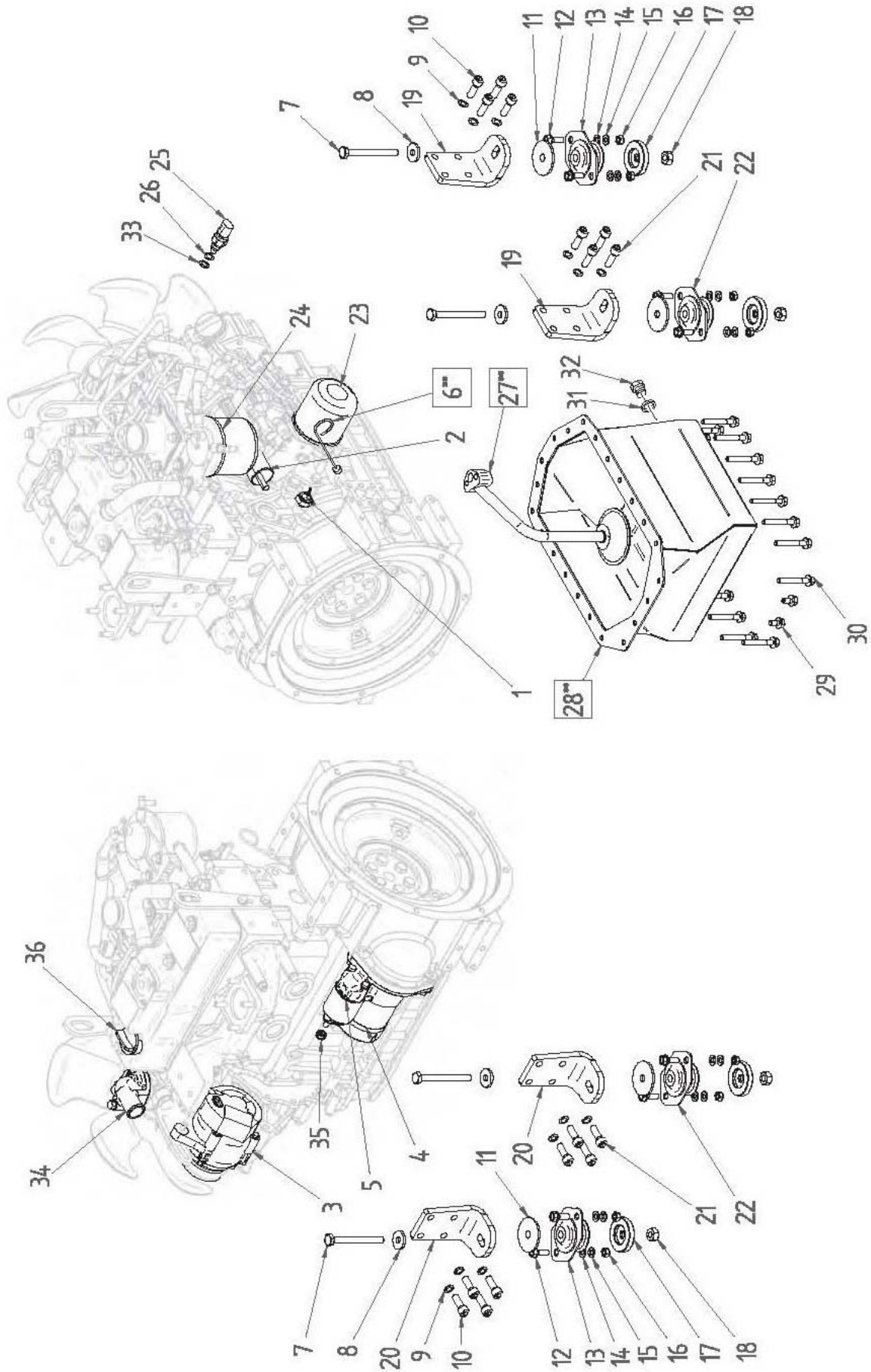

REF.	QTY.	PART No.	DESCRIPTION
			DIESEL ENGINE COMPONENTS
1	1	4000403	OIL SENSOR
2	1	4000404	SOLENOID
3	1	4000405	ALTERNATOR
4	1	4000406	STARTER MOTOR
5	1	4000407	SOLENOID (STARTER MOTOR)
6	1	4000408	DIPSTICK
7	4	4000409	SCREW
8	4	4000759	WASHER
9	16	4000410	KNURLED WASHER
10	8	4000411	SCREW
11	4	4000412	SILENCING WASHER
12	8	9300166	SCREW
13	2	4000414	REAR ANTI-VIBRATION MOUNTING
14	8	4000758	WASHER
15	8	4000415	WASHER
16	8	4000416	NUT
17	4	4000417	ANTI-VIBRATION BLOCK
18	4	4000418	NUT
19	1	4000419	ENGINE BRACKET LH
20	1	4000420	ENGINE BRACKET RH
21	1	4000421	SCREW
22	2	4000422	FRONT ANTI-VIBRATION MOUNTING
23	1	4000257	OIL FILTER
24	1	4000105	FUEL FILTER
25	1	4000698	WATER SENSOR
26	2	4000424	COPPER WASHER
27	1	4000425	SUCTION STRAINER
28	1	4000053	OIL SUMP
29	4	4000353	SCREW
30	20	4000812	SCREW
31	1	4000427	COPPER WASHER
32	1	4000428	DRAIN PLUG
33	1	4000813	ALUMINIUM WASHER
34	1	4000814	WATER PUMP
35	1	4000815	NUT
36	1	4000735	OIL FILLER CAP

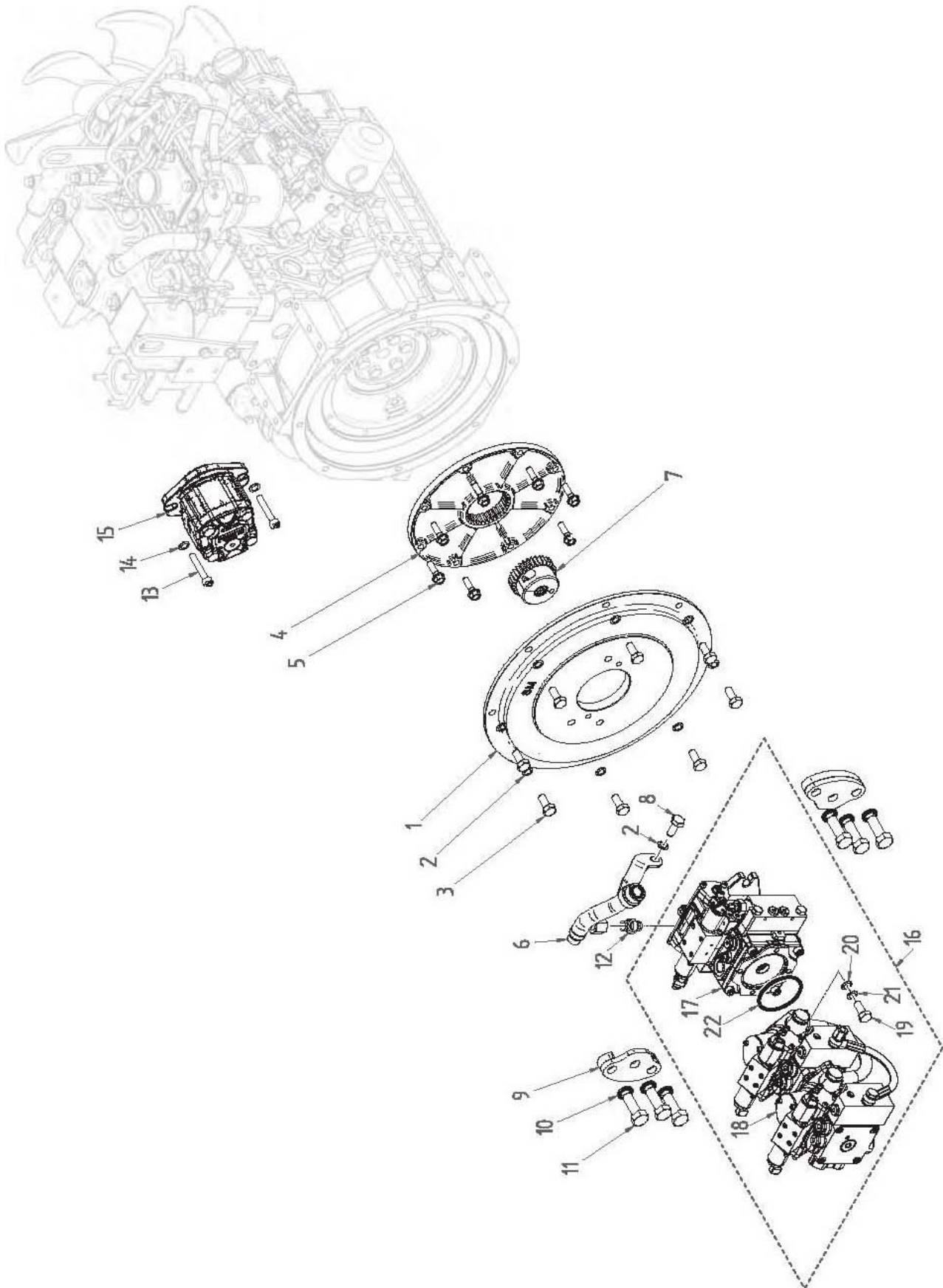

REF.	QTY.	PART No.	DESCRIPTION
			PUMPS ASSEMBLY
1	1	4000429	FLYWHEEL PUMP ADAPTOR
2	9	4000410	KNURLED WASHER
3	8	4000209	SCREW
4	1	4000297	FLYWHEEL
5	8	4000430	SCREW
6	1	4000431	PUMP MANIFOLD
7	1	4000432	GROOVED JOINT
8	1	4000440	SCREW
9	2	4000433	PUMP CLAMP
10	6	4000434	LOCK WASHER
11	6	4000435	SCREW
12	1	7315797	CONNECTOR
13	2	4000437	SCREW
14	2	4000758	WASHER
15	1	4000345	GEAR PUMP
16	1	4000439	PISTON PUMP ASSEMBLY - <i>comprising of;</i>
17	1	4000296	PUMP
18	1	4000436	TANDEM PISTON PUMP
19	2	4000210	SCREW
20	2	4000410	KNURLED WASHER
21	2	4000816	WASHER
22	1	4000438	O-RING

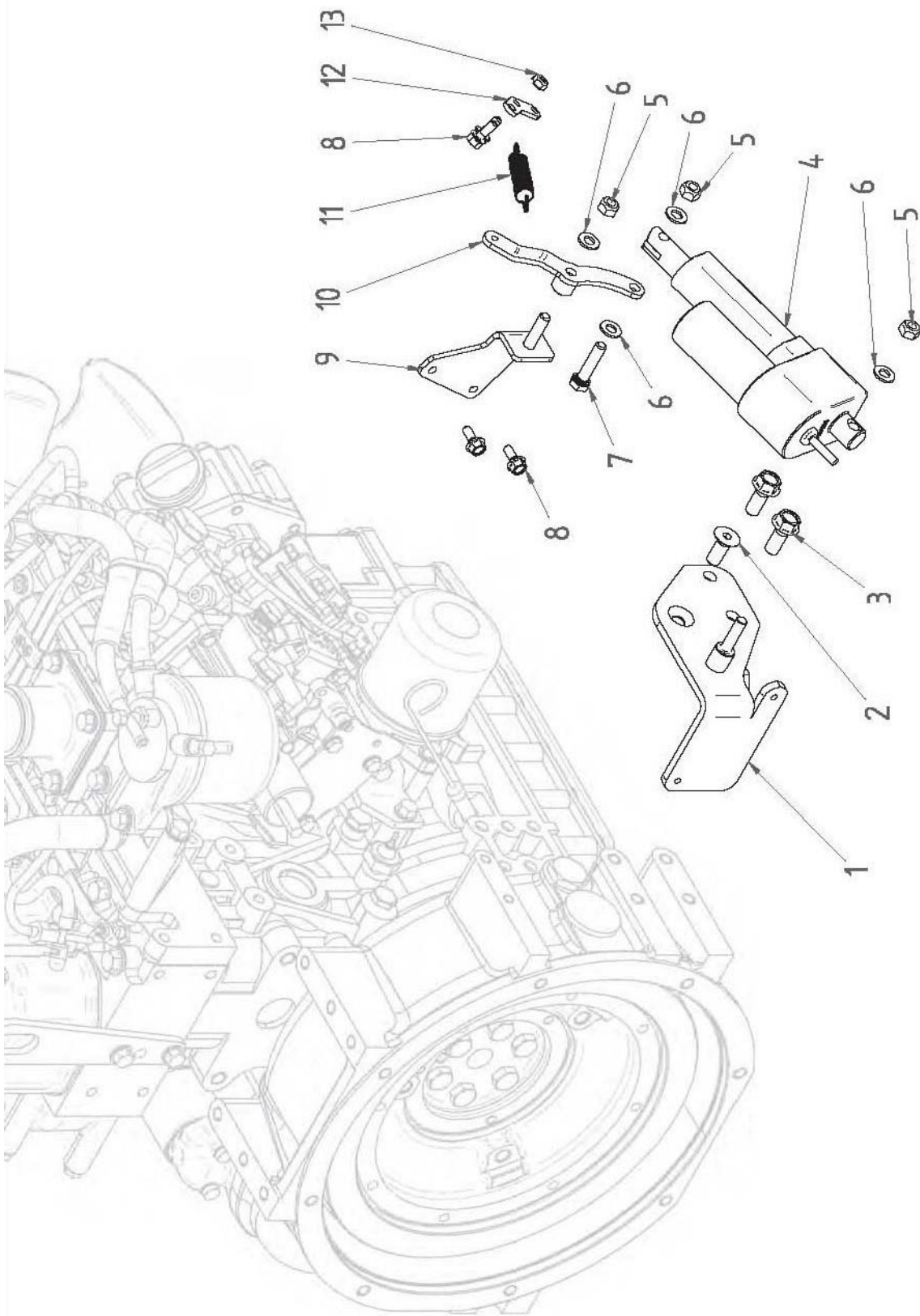

REF.	QTY.	PART No.	DESCRIPTION
			ACTUATOR ASSEMBLY
1	1	4000057	BRACKET
2	1	4000441	SCREW
3	2	4000442	SCREW
4	1	4000086	ACTUATOR
5	3	4000381	NUT
6	4	4000078	WASHER
7	1	4000806	SCREW
8	4	4000316	SCREW
9	1	4000058	THROTTLE BRACKET
10	1	4000059	ACTUATOR ARM
11	1	4000074	THROTTLE SPRING
12	1	4000060	SPRING LINKAGE
13	2	4000443	NUT

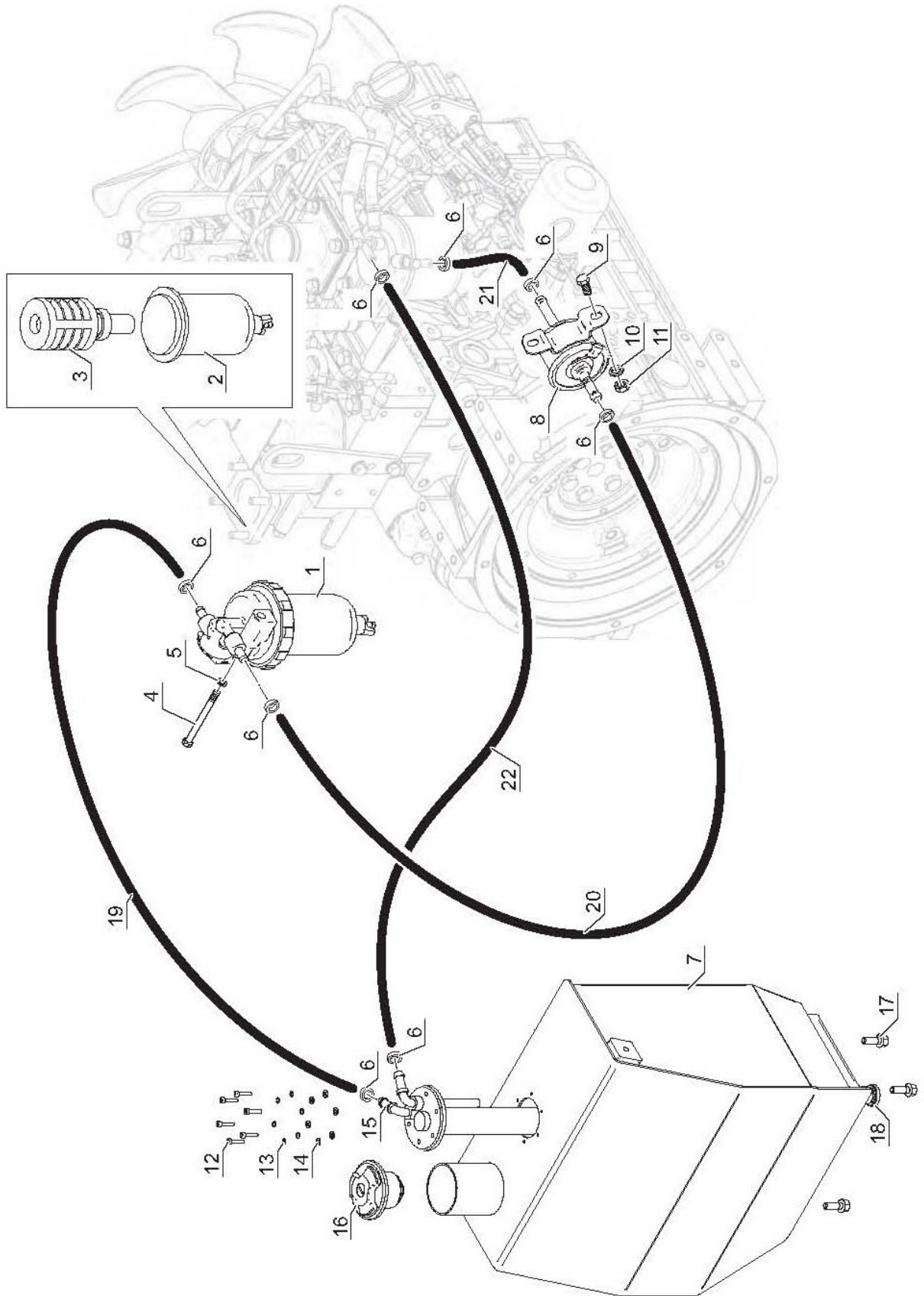

REF.	QTY.	PART No.	DESCRIPTION
			DIESEL FUEL CIRCUIT
1	1	4000292	PRIMARY FUEL FILTER
2	1	4000341	FUEL FILTER CAP
3	1	4000342	PRIMARY FUEL FILTER CARTRIDGE
4	1	4000547	SCREW
5	1	4000078	WASHER
6	8	4000467	HOSE CLAMP
7	1	4000096	FUEL TANK
8	1	4000126	FUEL PUMP
9	2	4000472	SCREW
10	2	4000789	WASHER
11	2	4000443	NUT
12	6	4000106	SCREW
13	6	4000113	WASHER
14	6	4000798	WASHER
15	1	4000473	FUEL LEVEL SENSOR
16	1	4000474	FUEL CAP
17	8	7315750	SCREW
18	2	4000127	PLUG
19	1	4000468	DIESEL HOSE
20	1	4000469	DIESEL HOSE
21	1	4000470	DIESEL HOSE
22	1	4000471	DIESEL HOSE

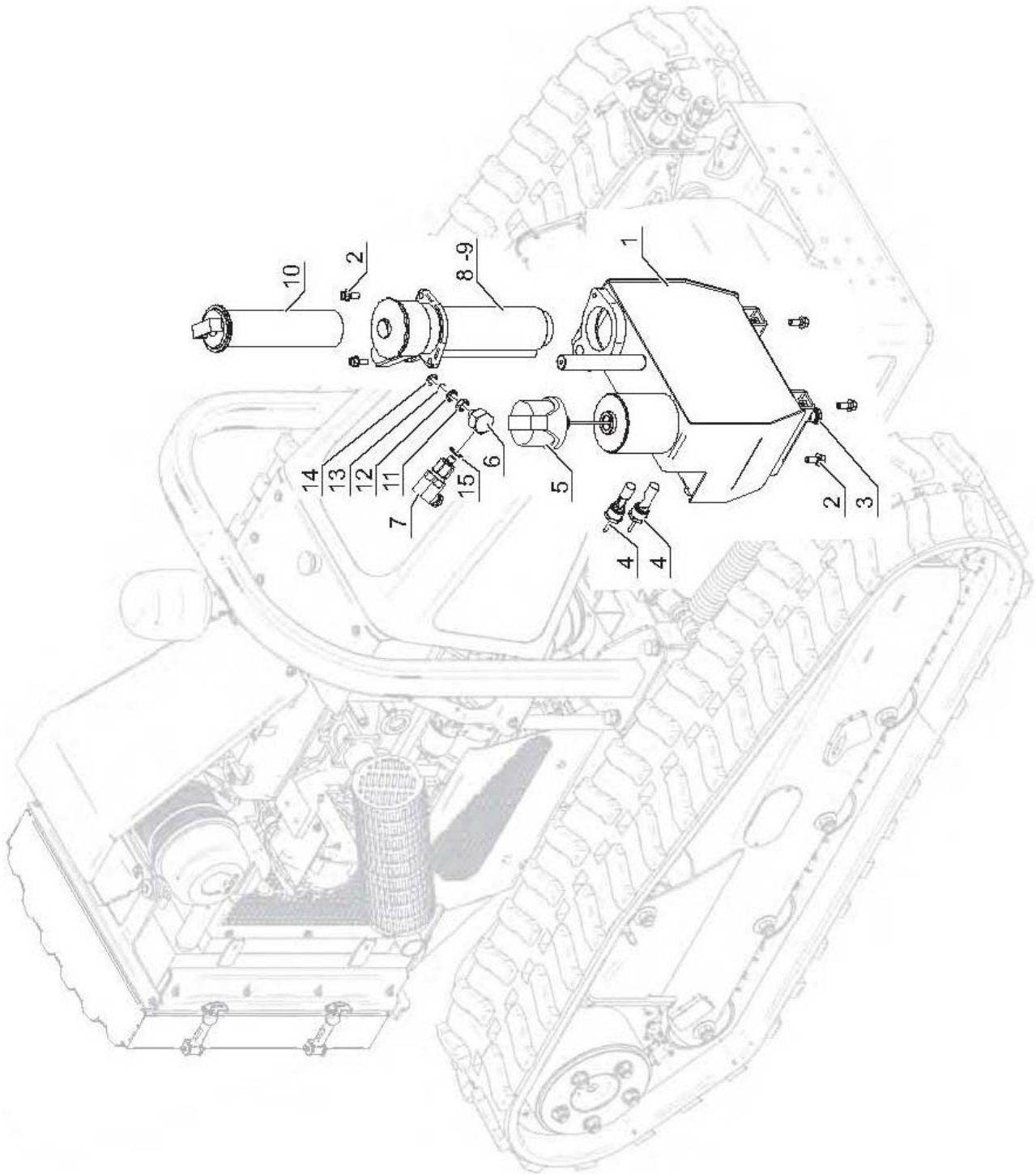

REF.	QTY.	PART No.	DESCRIPTION
			HYDRAULIC OIL TANK ASSEMBLY
1	1	4000097	OIL TANK
2	6	7315750	SCREW
3	2	4000127	PLUG
4	2	4000148	LEVEL SENSOR
5	1	4000124	OIL CAP
6	1	4000475	FILTER SENSOR BRACKET
7	1	4000476	OIL FILTER CLOGGING SWITCH
8	1	4000122	OIL FILTER HOUSING
9	1	4000817	OIL FILTER
10	1	4000259	FILTER ELEMENT
11	1	4000818	NUT
12	1	4000819	O-RING WASHER
13	1	4000820	O-RING
14	1	4000821	O-RING STOPPER
15	1	4000822	BOLT SEAL

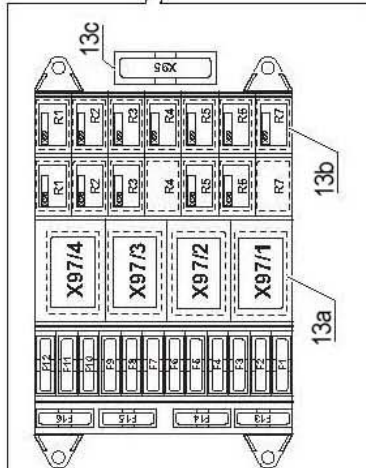
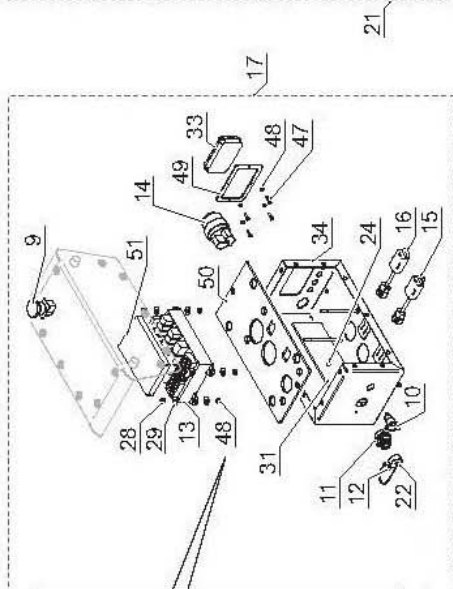
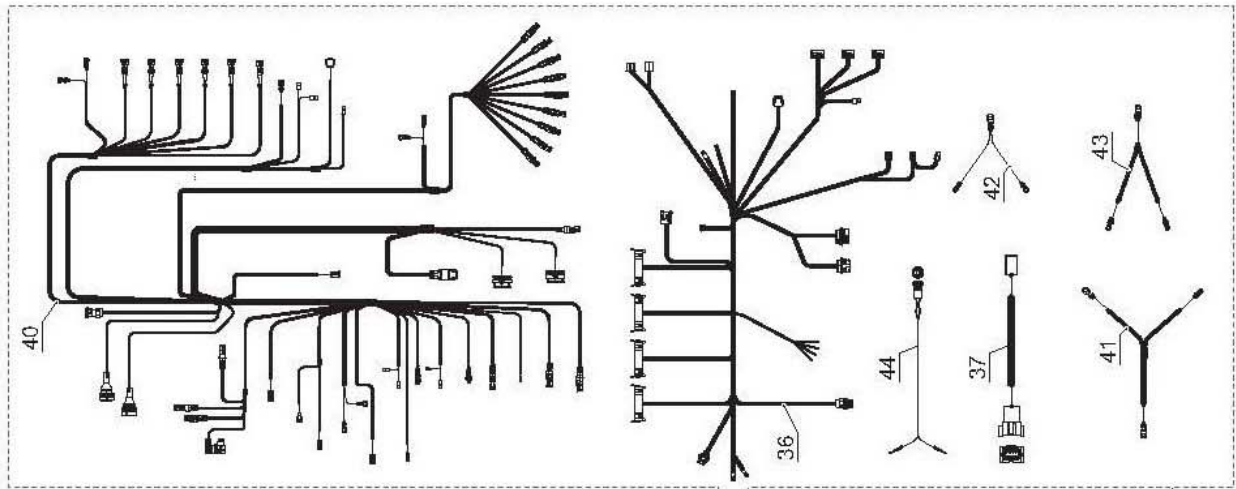

F1	E9 1109 0000 0075	7.5 Amp
F2	E9 1109 0000 0075	7.5 Amp
F3	E9 1109 0000 005A	5 Amp
F4	E9 1109 0000 10A	10 Amp
F5	E9 1109 0000 30A	30 Amp
F6	E9 1109 0000 005A	5 Amp
F7	E9 1109 0000 15A	15 Amp
F8	E9 1109 0000 10A	10 Amp
F9	E9 1109 0000 15A	15 Amp
F10	E9 1109 0000 003A	3 Amp
F11	E9 1109 0000 005A	5 Amp
F12	E9 1109 0000 005A	5 Amp
F13	E9 1109 0000 20A	20 Amp
F14	E9 1109 0000 10A	10 Amp
F15	E9 1109 0000 0075	7.5 Amp
F16	E9 1109 0000 003A	3 Amp
X95	E9 1109 0000 40A	40 Amp

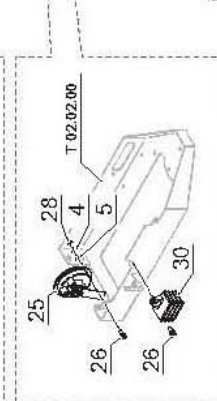
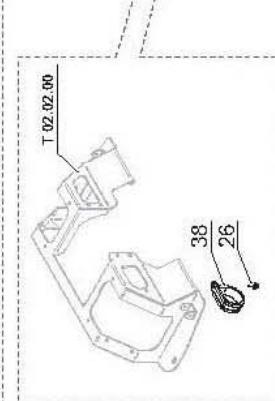
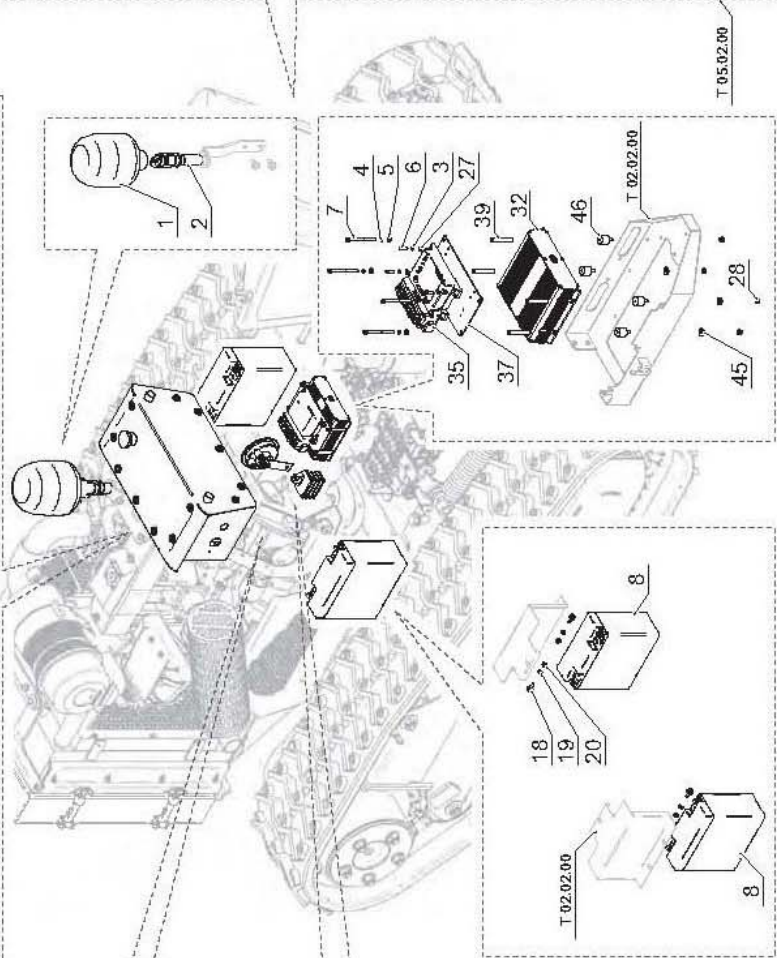

REF.	QTY.	PART No.	DESCRIPTION
			ELECTRICAL COMPONENTS
1	1	4000283	ROTATING LIGHT (BEACON)
2	1	4000284	LIGHT CONNECTION
3	4	4000823	WASHER
4	5	4000544	WASHER
5	5	4000789	WASHER
6	4	4000824	SCREW
7	4	4000452	SCREW
8	2	4000181	BATTERY
9	1	4000306	RED EMERGENCY SWITCH
10	1	4000307	PLUG
11	1	4000308	CONNECTOR
12	2	4000309	SCREW
13	1	4000825	RELAYS FUSE BOX
13a	4	4000302	RELAY WITH DIODE
13b	21	4000303	MICRO RELAY
13c	1	4000311	FUSE
14	1	4000145	IGNITION SWITCH
15	1	4000313	PRE AIR HEATER
16	1	4000326	INJECTION PUMP DELAY
17	1	4000802	ELECTRICAL BOX
18	4	4000316	SCREW
19	4	4000789	WASHER
20	4	4000075	NUT
21	1	4000826	WIRING LOOMS - ELECTRICAL SYSTEM
22	1	4000318	CONNECTOR PLUG
23	1	4000798	WASHER
24	1	4000799	LOCK NUT
25	1	4000301	HORN
26	3	4000316	SCREW
27	4	4000827	WASHER
28	8	4000791	LOCK NUT
29	8	4000321	WASHER
30	1	4000322	SHUNT BOX
31	1	4000828	SOUNDPROOF PROTECTION
32	1	4000829	CONTROL UNIT
33	1	4000830	INDICATOR
34	1	4000831	BOX PROTECTION
35	1	4000832	RECEIVER UNIT
36	1	4000833	WIRING LOOM - CONTROL UNIT
37	1	4000834	SUPPORT RECEIVER
38	1	4000835	CLIP
39	4	4000836	DISTANCE PIECE
40	1	4000837	WIRING LOOM - CHASSIS LINE

Continued...

REF.	QTY.	PART No.	DESCRIPTION
			ELECTRICAL COMPONENTS (Robocut Pure)
41	1	4000329	BATTERY CABLE - POSITIVE (+)
42	1	4000330	BATTERY CABLE - NEGATIVE (-)
43	1	4000331	STARTER MOTOR/ALTERNATOR POWER LINE
44	1	4000838	SWITCH
45	4	4000114	WASHER
46	4	4000839	ANTI-VIBRATION
47	4	4000840	SCREW
48	8	4000841	NUT
49	1	4000842	INDICATOR FASTENING
50	1	4000843	SOUNDPROOF PROTECTION
51	1	4000844	INNER SOUNDPROOF PROTECTION

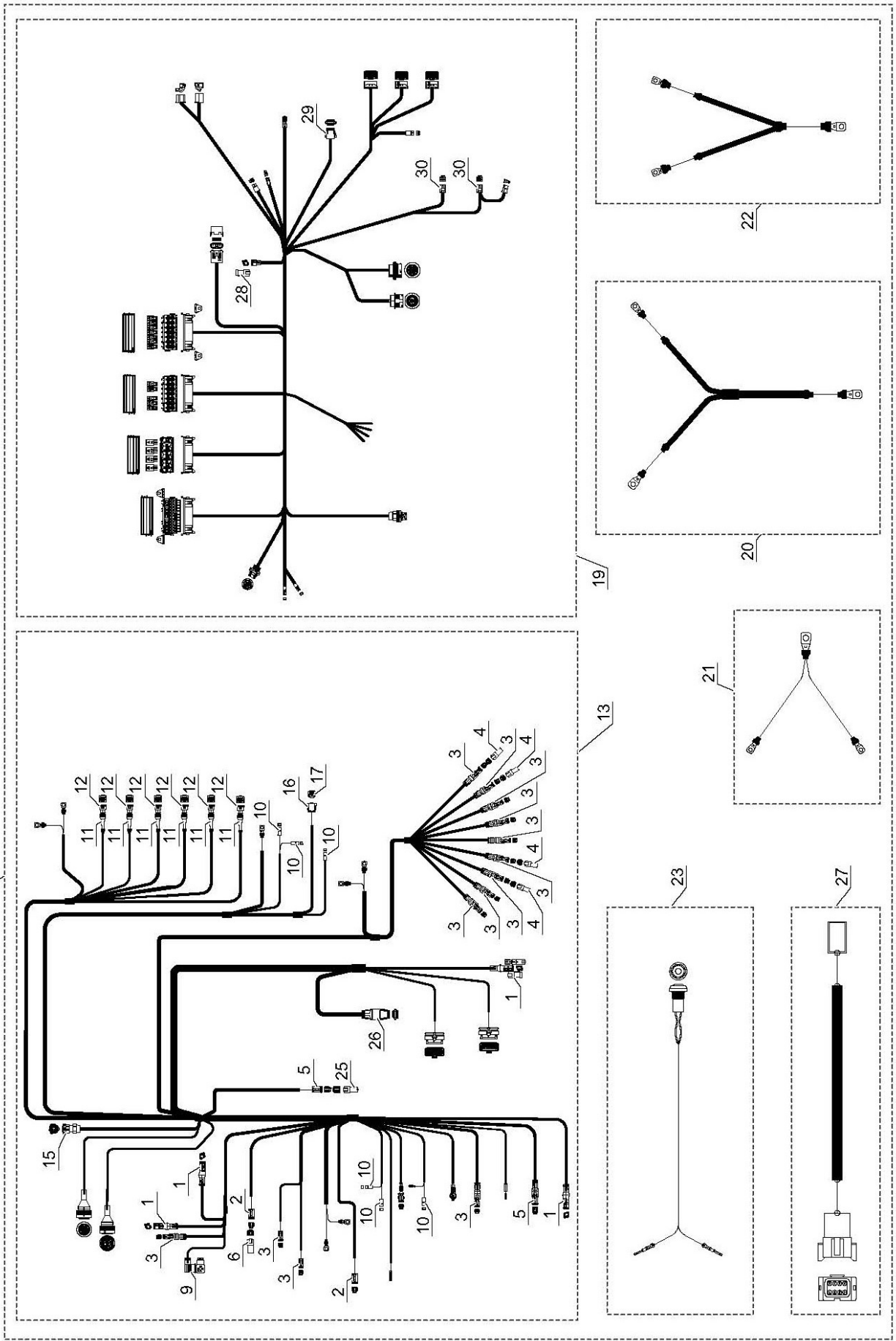

REF.	QTY.	PART No.	DESCRIPTION
			ELECTRICAL WIRING (Robocut Pure)
1	4	4000477	CONNECTOR
2	2	4000478	CONNECTOR
3	11	4000479	CONNECTOR
4	2	4000480	CONNECTOR
5	1	4000481	CONNECTOR
6	1	4000482	CONNECTOR
7	1	4000483	CONNECTOR
8	2	4000484	CONNECTOR
9	1	4000485	CONNECTOR
10	5	4000486	CONNECTOR
11	7	4000487	RUBBER CABLE SLEEVE
12	7	4000337	CONNECTOR
13	1	4000837	WIRING LOOM - CHASSIS LINE
14	2	4000488	CONNECTOR
15	1	4000489	CONNECTOR
16	1	4000490	CONNECTOR
17	1	4000491	RUBBER COVER
18	2	4000492	CONNECTOR
19	1	4000833	WIRING LOOM - CONTROL UNIT
20	1	4000329	BATTERY CABLE - POSITIVE (+)
21	1	4000330	BATTERY CABLE - NEGATIVE (-)
22	1	4000331	STARTER MOTOR/ALTERNATOR POWER LINE
23	1	4000838	SWITCH
24	1	4000826	WIRING LOOMS - ELECTRICAL SYSTEM
25	1	4000845	CONNECTOR
26	1	4000846	CONNECTOR
27	1	4000847	REMOTE CONTROL LINE
28	1	4000477	CONNECTOR
29	1	4000846	CONNECTOR
30	1	4000848	CONNECTOR

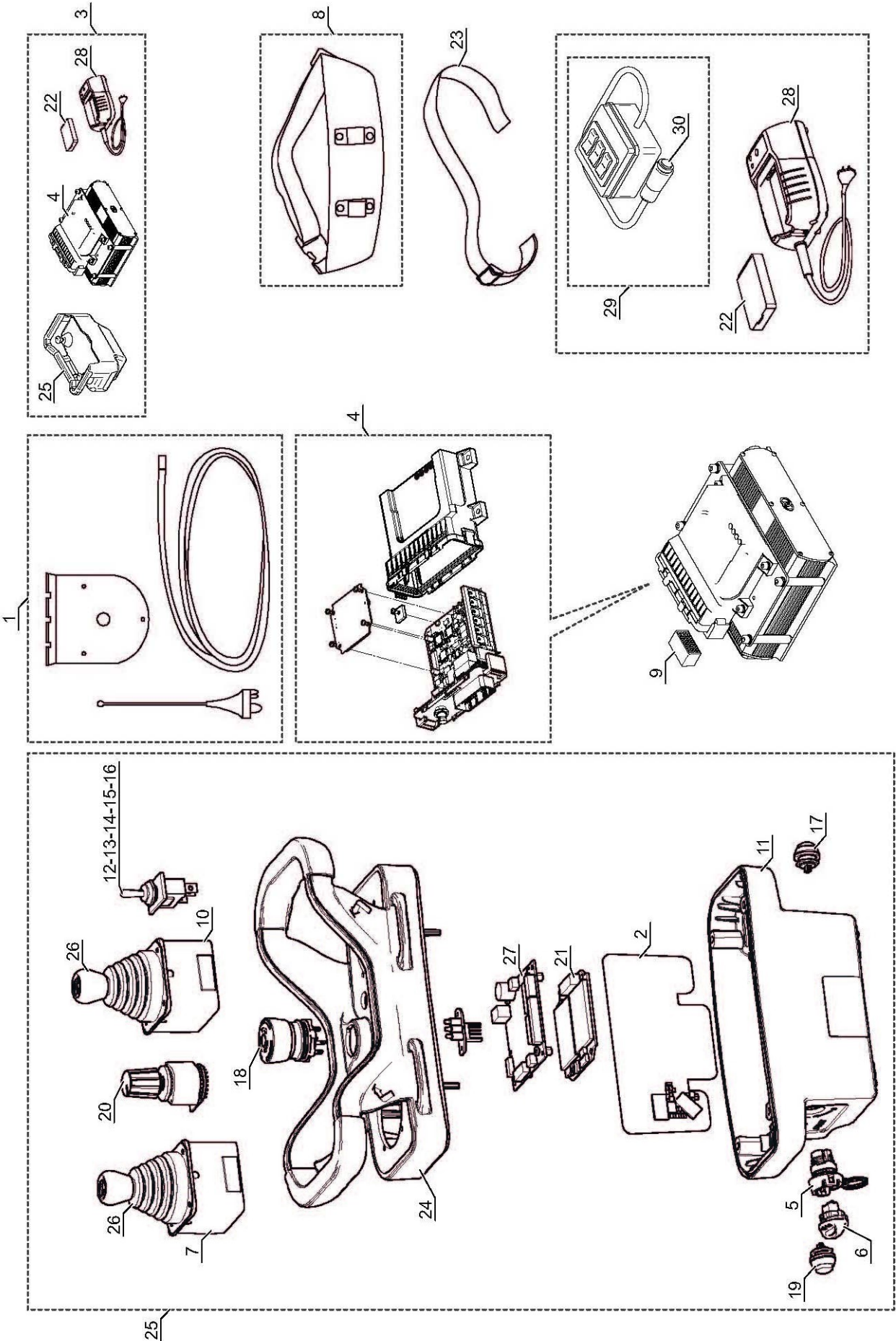

REF.	QTY.	PART No.	DESCRIPTION
			REMOTE CONTROL
1	1	4000282	ANTENNA WITH CABLE
2	1	4000849	ANTENNA 870 MHZ
3	1	4000750	REMOTE CONTROL KIT
4	1	4000832	RECEIVER UNIT
5	1	4000718	START KEY CONNECTOR KIT
6	1	4000349	START KEY
7	1	4000719	PROPORTIONAL JOYSTICK
8	1	4000500	WAIST BELT
	1	4000501	WAIST BELT XXL
9	1	4000502	KIT SOCKET
10	1	4000503	PROPORTIONAL JOYSTICK
11	1	4000850	LOWER CONTROL UNIT
12	1	4000721	TOGGLE SWITCH
13	1	4000722	TOGGLE SWITCH
14	1	4000723	TOGGLE SWITCH
15	2	4000724	TOGGLE SWITCH
16	1	4000725	TOGGLE SWITCH
17	1	4000510	BLACK PUSH BUTTON
18	1	4000511	STOP PUSH BUTTON
19	1	4000512	GREEN PUSH BUTTON
20	1	4000513	POTENTIOMETRIC SELECTOR
21	1	4000514	RADIO MODULE
22	1	4000270	REMOTE CONTROL BATTERY
23	1	4000733	SHOULDER BELT
24	1	4000851	FRAME
25	1	4000852	TRANSMITTER
26	1	4000519	JOYSTICK GAITOR
27	1	4000525	CODER CARD
28	1	4000526	BATTERY CHARGER
29	1	4000527	WIRED EMERGENCY REMOTE
30	1	4000734	CONNECTOR

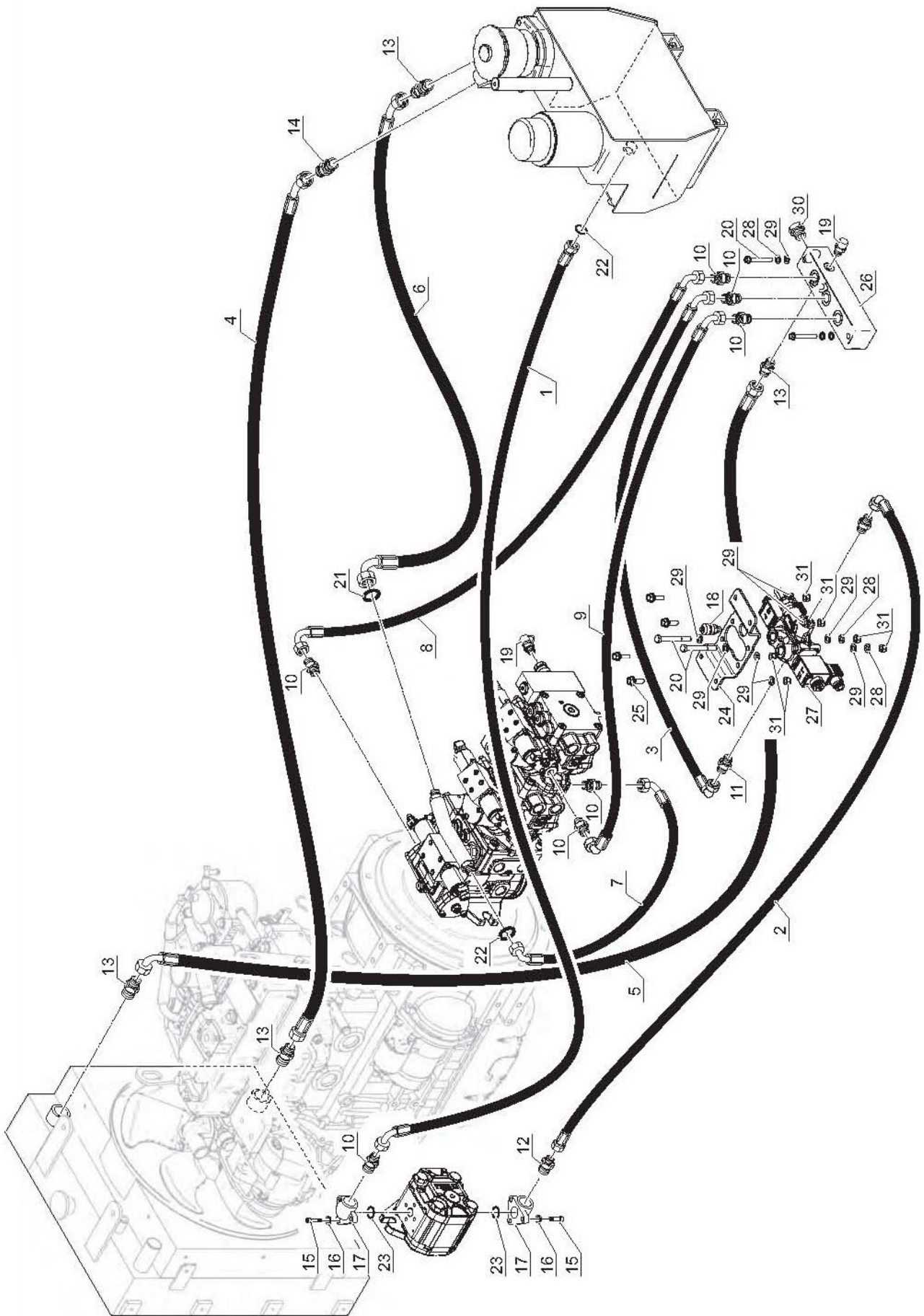

REF.	QTY.	PART No.	DESCRIPTION
			INTAKE & DRAIN PUMPS
1	1	4000853	HYDRAULIC HOSE
2	1	4000854	HYDRAULIC HOSE
3	1	4000855	HYDRAULIC HOSE
4	1	4000856	HYDRAULIC HOSE
5	1	4000857	HYDRAULIC HOSE
6	1	4000858	HYDRAULIC HOSE
7	1	4000859	HYDRAULIC HOSE
8	1	4000860	HYDRAULIC HOSE
9	1	4000861	HYDRAULIC HOSE
10	7	7315797	CONNECTOR
11	2	7315777	CONNECTOR
12	1	7315775	CONNECTOR
13	4	7315774	CONNECTOR
14	1	4000542	CONNECTOR
15	6	4000543	SCREW
16	6	4000544	WASHER
17	2	4000545	PUMP CONNECTION
18	1	4000546	CHECK COUPLING
19	2	7315769	CHECK COUPLING
20	4	4000547	SCREW
21	1	4000548	O-RING
22	2	4000549	O-RING
23	2	4000550	O-RING
24	1	4000862	VALVE BLOCK BRACKET
25	4	4000445	SCREW
26	1	4000552	OIL MANIFOLD
27	1	4000863	VALVE BLOCK
28	4	7315559	WASHER
29	10	4000078	WASHER
30	1	4000864	PLUG
31	6	4000865	LOCK NUT

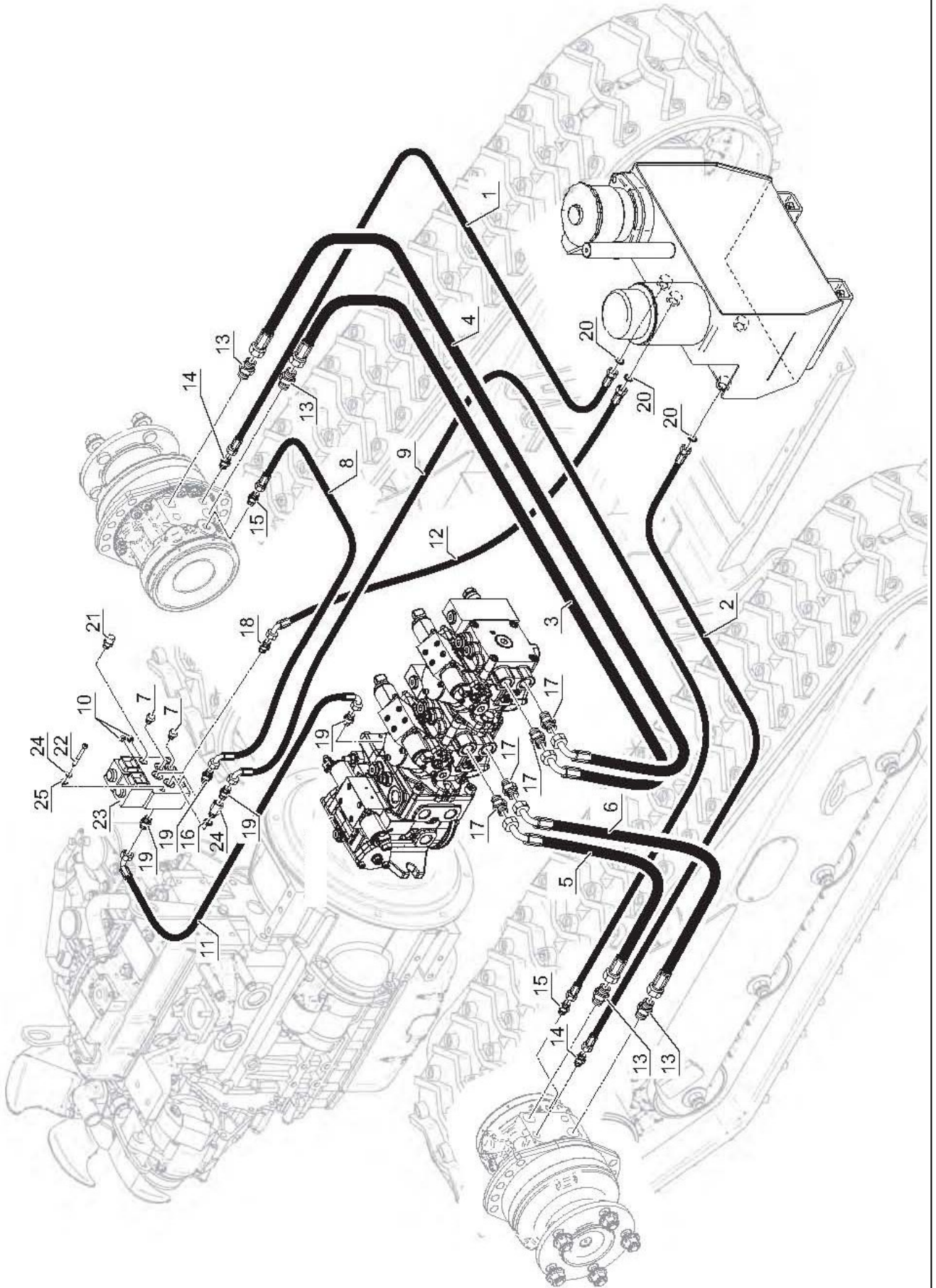

REF.	QTY.	PART No.	DESCRIPTION
			TRACK HYDRAULIC CIRCUIT
1	1	4000866	HYDRAULIC HOSE
2	1	4000867	HYDRAULIC HOSE
3	1	4000868	HYDRAULIC HOSE
4	1	4000869	HYDRAULIC HOSE
5	1	4000870	HYDRAULIC HOSE
6	1	4000871	HYDRAULIC HOSE
7	2	4000872	PLUG
8	1	4000873	HYDRAULIC HOSE
9	1	4000874	HYDRAULIC HOSE
10	2	4000582	PLUG
11	1	4000875	HYDRAULIC HOSE
12	1	4000876	HYDRAULIC HOSE
13	4	4000576	CONNECTOR
14	2	4000577	CONNECTOR
15	2	4000578	CONNECTOR
16	1	4000822	BONDED SEAL
17	4	7315775	CONNECTOR
18	1	4000560	CONNECTOR
19	3	4000579	CONNECTOR
20	3	4000549	O-RING
21	1	4000546	CHECK COUPLING
22	2	4000580	SCREW
23	1	4000522	SPEED-BRAKE VALVE
24	2	4000789	WASHER
25	2	4000544	WASHER

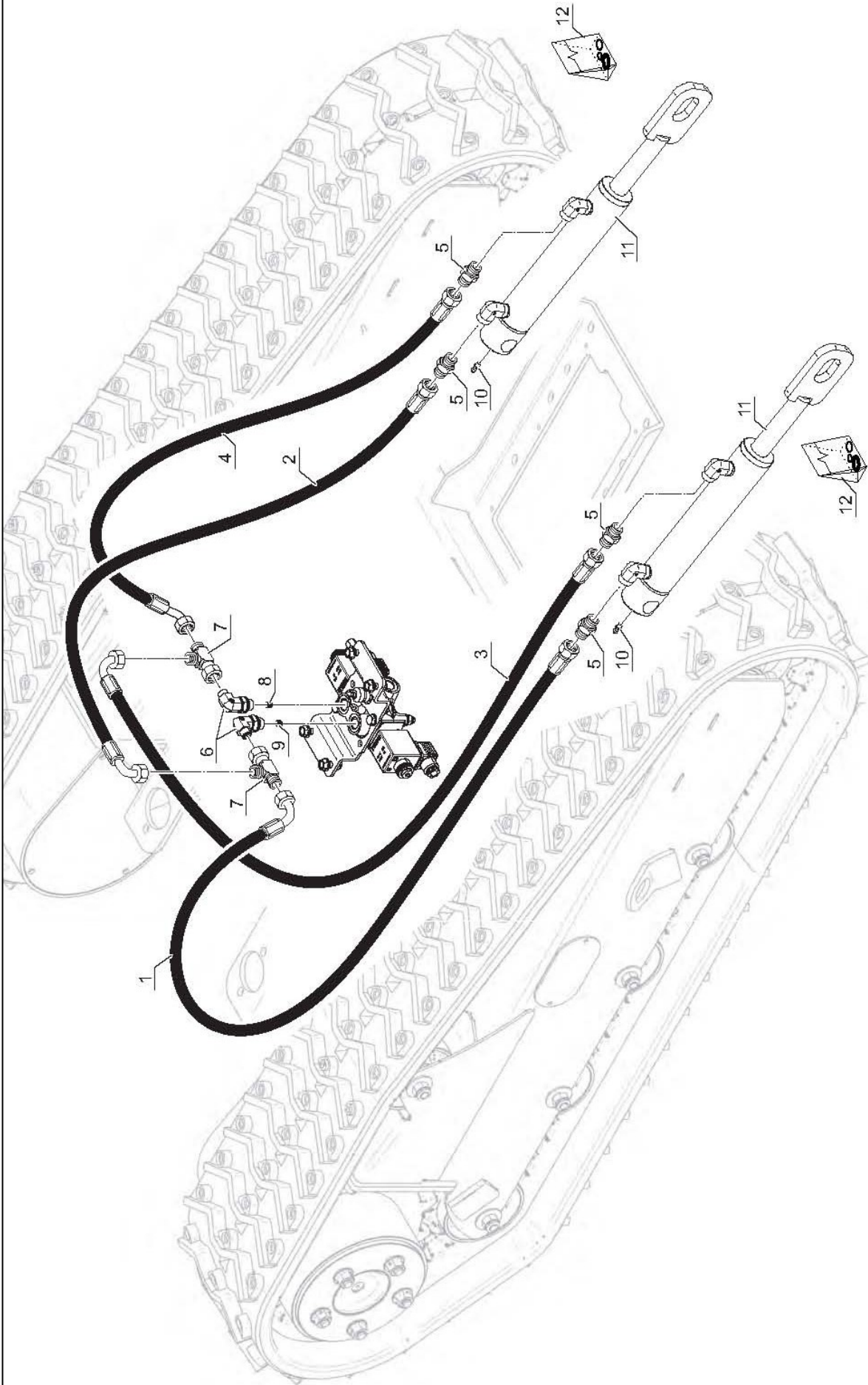

REF.	QTY.	PART No.	DESCRIPTION
			HYDRAULIC RAMS CIRCUIT
1	1	4000877	HYDRAULIC HOSE
2	1	4000878	HYDRAULIC HOSE
3	1	4000879	HYDRAULIC HOSE
4	1	4000880	HYDRAULIC HOSE
5	4	4000579	CONNECTOR
6	2	4000881	FITTING
7	2	4000588	TEE CONNECTOR
8	1	4000882	RESTRICTOR
9	1	4000697	RESTRICTOR
10	2	4000368	GREASE NIPPLE
11	2	4000101	HYDRAULIC RAM
12	2	4000883	SEAL KIT FOR RAM 4000101

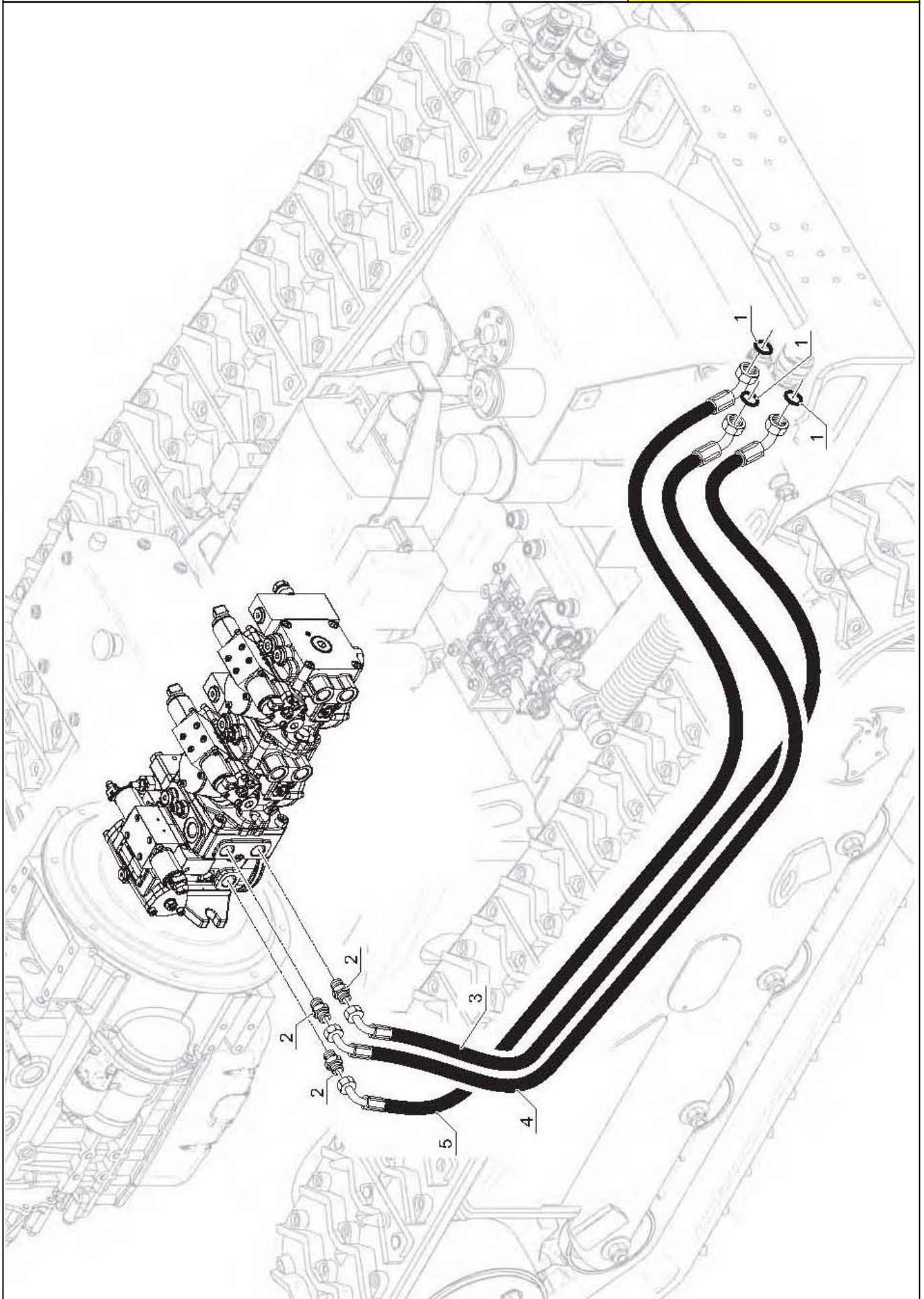

REF.	QTY.	PART No.	DESCRIPTION
			EQUIPMENT HYDRAULIC CIRCUIT
1	3	4000549	O-RING
2	3	7315797	CONNECTOR
3	1	4000884	HYDRAULIC HOSE
4	1	4000885	HYDRAULIC HOSE
5	1	4000886	HYDRAULIC HOSE

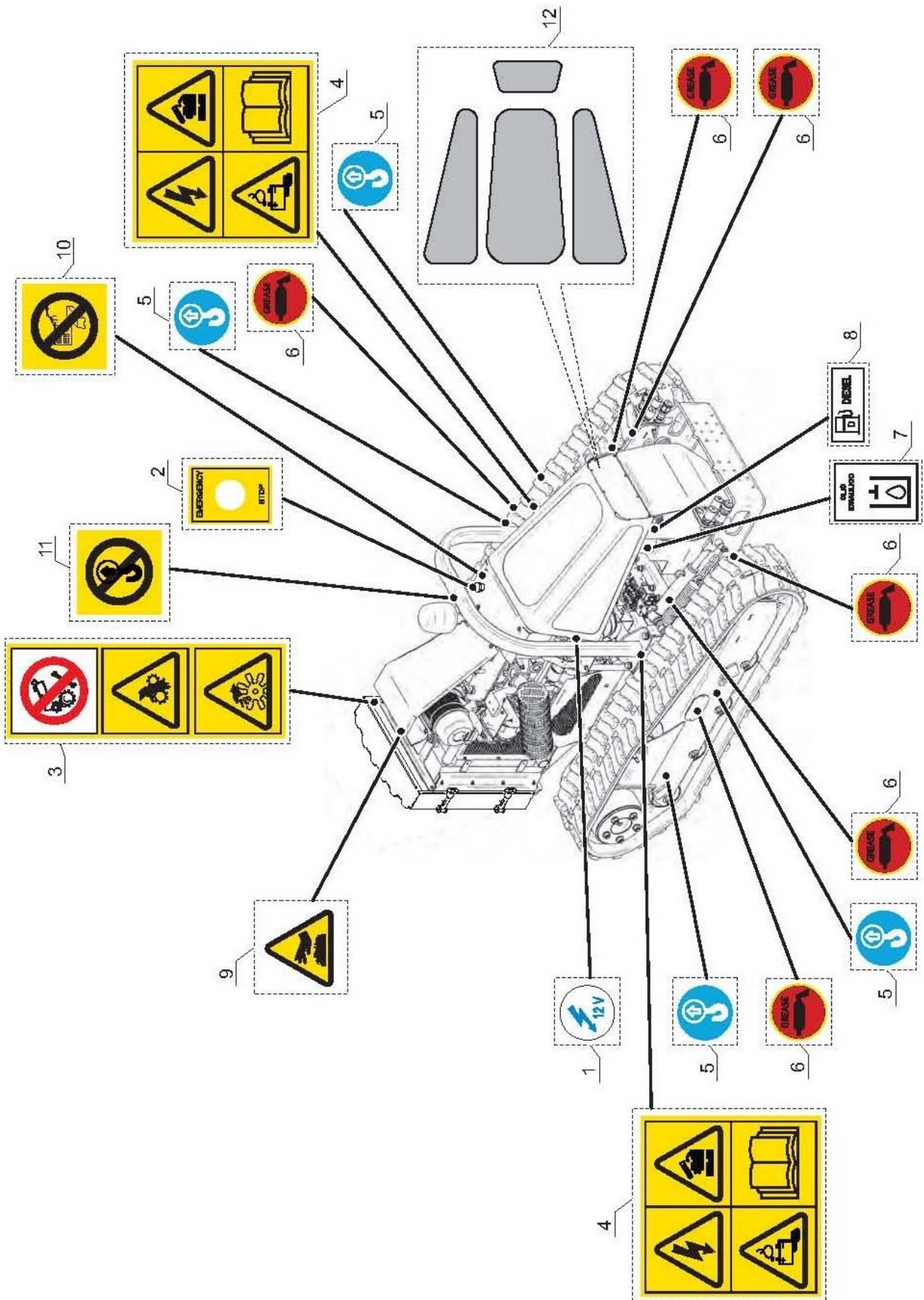

REF.	QTY.	PART No.	DESCRIPTION
			MACHINE DECAL KIT
1	1	4000887	DECAL - 12 VOLT
2	1	4000888	DECAL - EMERGENCY STOP
3	1	4000889	DECAL - NO LUBRICATION
4	2	4000890	DECAL - BATTERY
5	4	4000891	DECAL - LIFTING HOOK
6	6	4000769	DECAL - GREASE
7	1	4000892	DECAL - HYDRAULIC OIL
8	1	4000893	DECAL - FUEL
9	1	4000894	DECAL - HOT SURFACES
10	1	4000895	DECAL - NO WATER
11	1	4000896	DECAL - NO LIFTING
12	1	4000897	DECAL - UPPER BONNET KIT

1.3M FLAILHEAD ASSEMBLY

ROBOCUT PURE

McCONEL

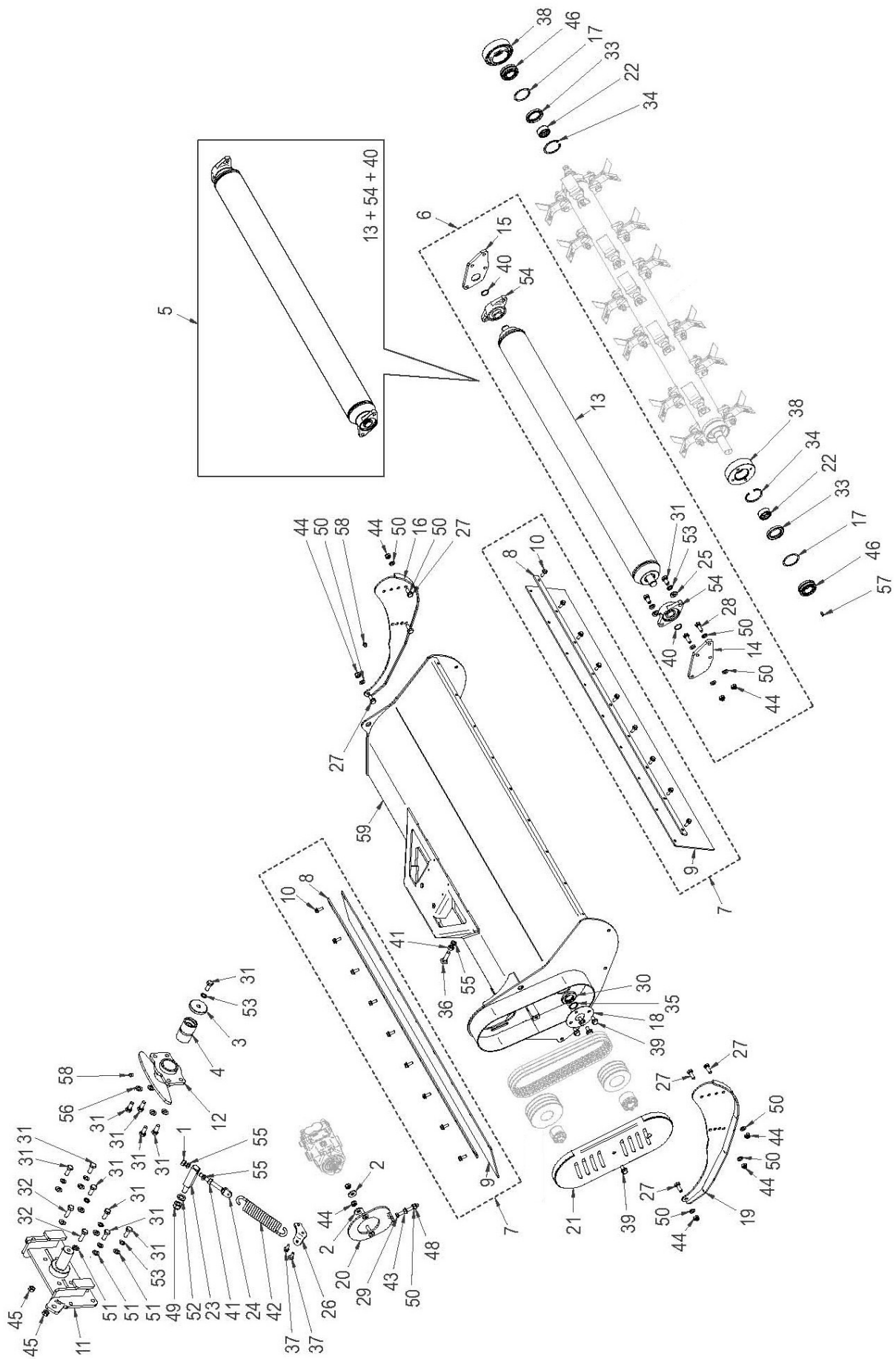

REF.	QTY.	PART No.	DESCRIPTION
			1.3M FLAILHEAD (Robocut Pure)
1	1	4000751	LOCK NUT
2	2	4000040	WASHER
3	1	4000238	WASHER
4	1	4000237	BUSH
5	1	4000739	REAR ROLLER c/w BEARINGS
6	1	4000752	REAR ROLLER COMPLETE
7	2	4000702	FLAP KIT - <i>comprising of:</i>
8	2	4000188	CLAMP STRIP
9	2	4000189	RUBBER FLAP
10	18	4000380	FLANGED HEAD SCREW
11	1	4000192	HEAD PIVOT BRACKET
12	1	4000193	PIVOT JOINT
13	1	4000194	REAR ROLLER
14	1	4000195	ROLLER BRACKET RH
15	1	4000196	ROLLER BRACKET LH
16	1	4000197	SKID LH
17	2	4000198	WASHER
18	1	4000199	PLATE
19	1	4000200	SKID RH
20	1	4000201	MOTOR MOUNTING PLATE
21	1	4000202	BELT COVER
22	2	4000236	OIL SEAL GUIDE
23	1	4000205	SPRING TENSIONER FIXING
24	1	4000206	SPRING TENSIONER
25	4	4000753	WASHER
26	1	4000338	SPRING BRACKET
27	6	4000754	HEX HEAD SCREW
28	4	4000755	HEX HEAD SCREW
29	1	4000208	HEX HEAD SCREW
30	1	4000234	OIL SEAL
31	15	4000212	HEX HEAD SCREW
32	2	4000681	HEX HEAD SCREW
33	2	4000267	OIL SEAL
34	2	4000024	CIRCLIP
35	1	4000228	RETAINING RING
36	2	4000215	CUP HEAD BOLT
37	2	4000353	FLANGED HEAD SCREW
38	2	4000191	BEARING COLLAR
39	9	4000442	FLANGED HEAD SCREW
40	2	4000023	CIRCLIP
41	3	4000218	NUT
42	1	4000749	TENSIONING SPRING
43	1	4000220	FLANGED NUT
44	12	4000416	NUT

REF.	QTY.	PART No.	DESCRIPTION
			1.3M FLAILHEAD (Robocut Pure)
45	2	4000077	NUT
46	2	4000226	BEARING
47	2	4000221	LOCK NUT
48	1	4000756	LOCK NUT
49	1	4000757	LOCK NUT
50	21	4000758	WASHER
51	8	4000759	WASHER
52	1	4000253	WASHER
53	11	4000760	WASHER
54	2	4000225	FLANGE BEARING
55	4	4000761	WASHER
56	4	4000357	WASHER
57	1	4000368	GREASER
58	2	4000224	GREASER
59	1	4000762	HEAD CASING

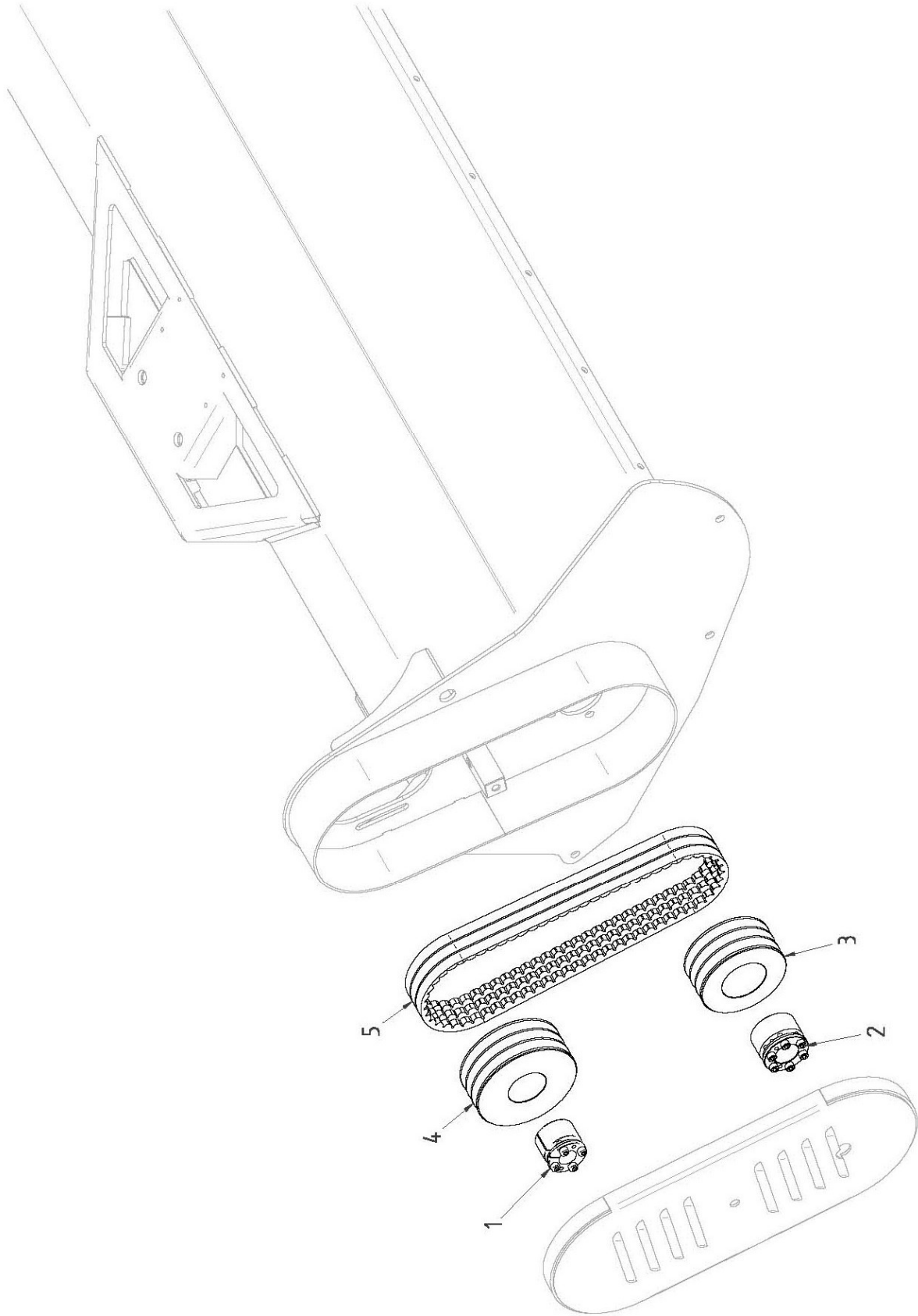

REF.	QTY.	PART No.	DESCRIPTION
			BELT DRIVE ASSEMBLY
1	1	4000531	TAPER LOCK
2	1	4000227	TAPER LOCK
3	1	4000231	PULLEY
4	1	4000232	PULLEY
5	3	4000233	DRIVE BELT

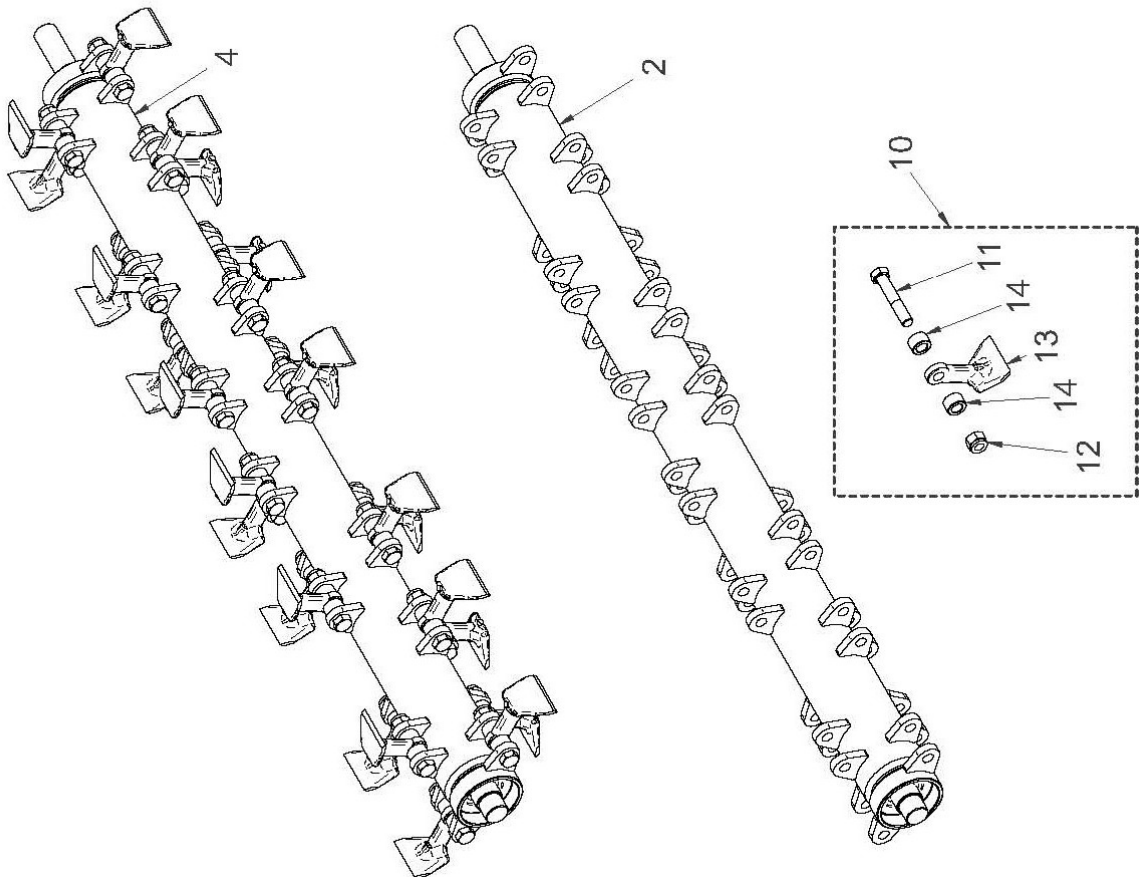
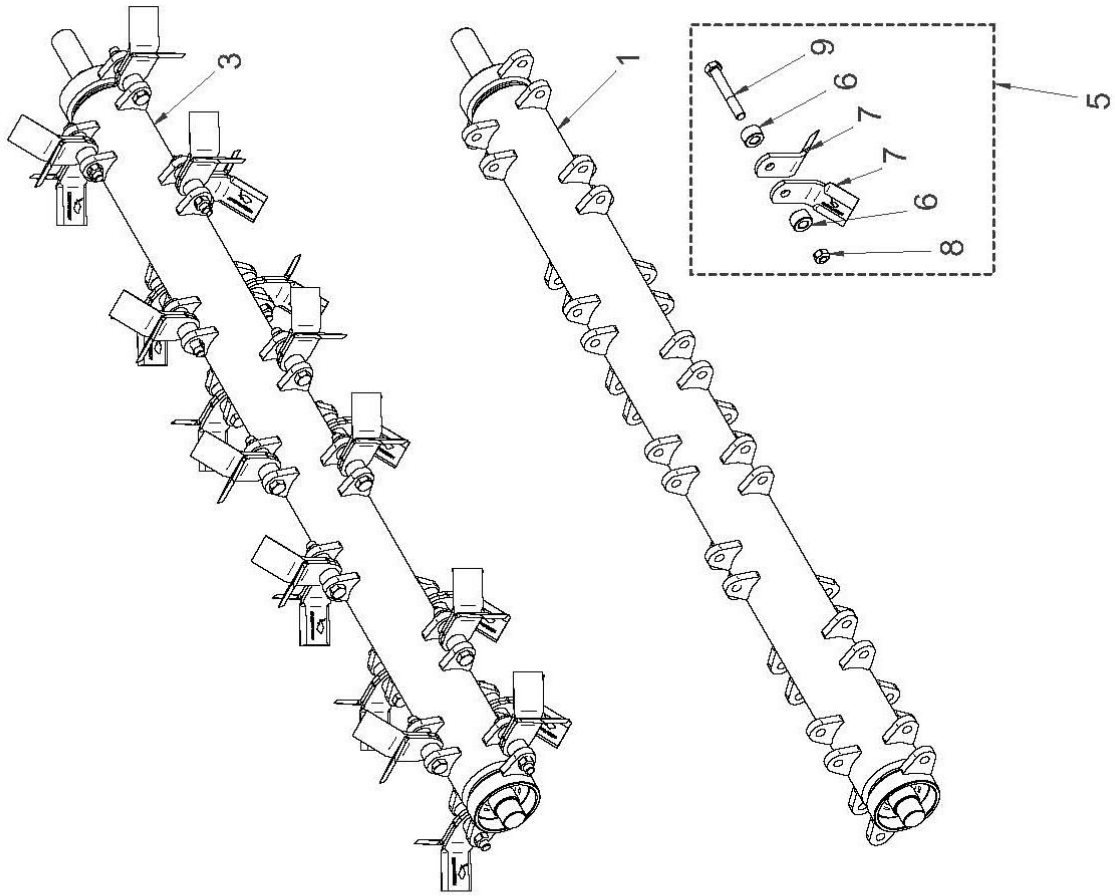

REF.	QTY.	PART No.	DESCRIPTION
			ROTORS & FLAILS OPTIONS
1	1	4000190	ROTOR (Y-FLAIL TYPE)
2	1	4000244	ROTOR (HAMMER FLAIL TYPE)
3	1	4000703	ROTOR c/w Y-FLAILS
4	1	4000704	ROTOR c/w HAMMER FLAILS
5	1	4000763	Y-FLAILS KIT
6	2	4000421	BUSH
7	2	4000764	Y-FLAIL
8	1	4000248	NUT
9	2	4000246	HEX HEAD SCREW
10	1	4000256	HAMMER FLAIL KIT
11	1	4000247	HEX HEAD SCREW
12	1	4000355	LOCK NUT
13	1	4000243	HAMMER FLAIL
14	2	4000245	BUSH

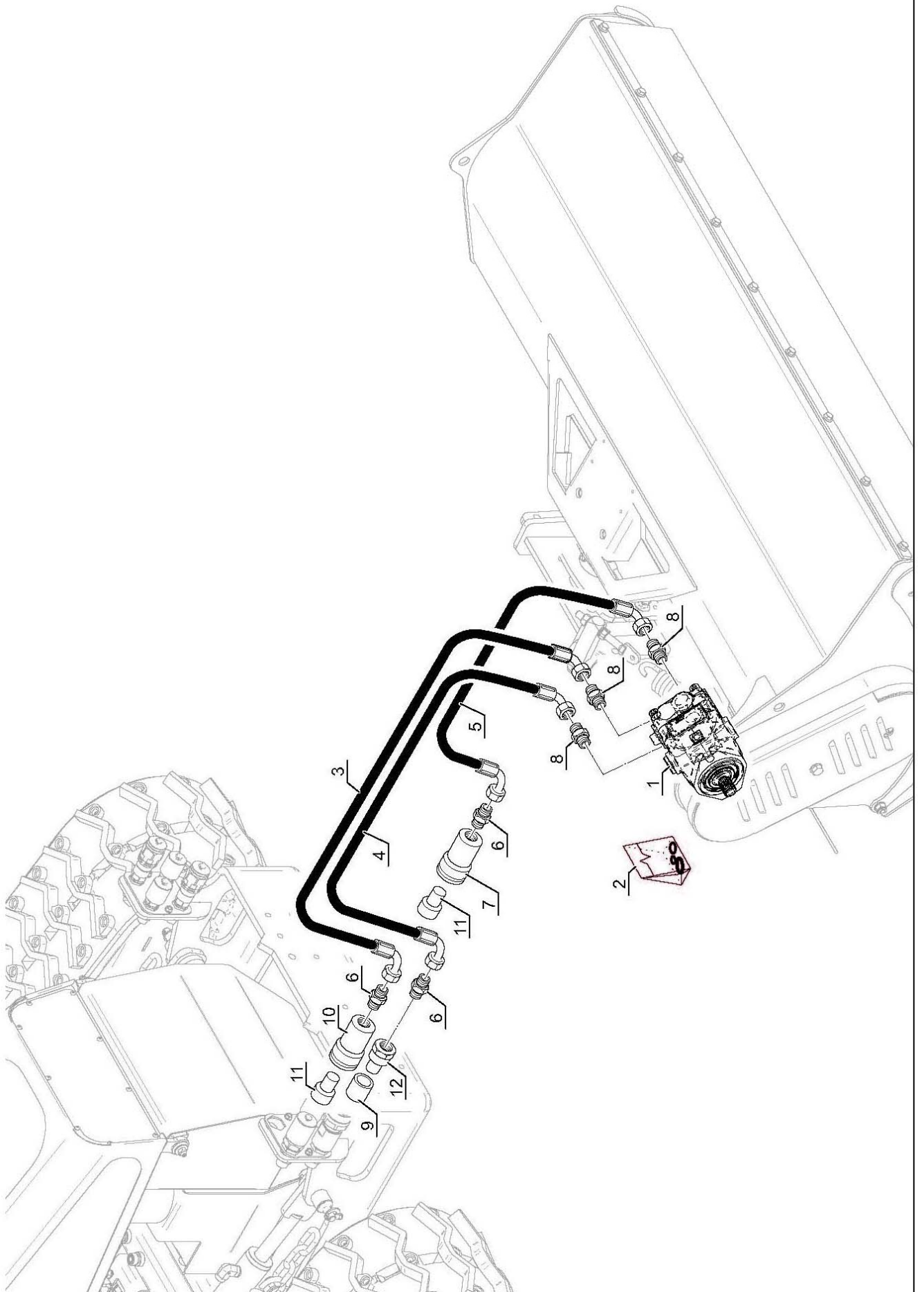

REF.	QTY.	PART No.	DESCRIPTION
			HYDRAULIC INSTALLATION
1	1	4000229	MOTOR
2	1	4000716	MOTOR GASKET KIT
3	1	4000765	HYDRAULIC HOSE
4	1	4000766	HYDRAULIC HOSE
5	1	4000767	HYDRAULIC HOSE
6	3	7315797	CONNECTOR
7	1	4000667	QR COUPLING
8	3	4000748	CONNECTOR
9	1	4000137	PLUG
10	1	4000133	QR COUPLING
11	2	4000139	PLUG
12	1	4000136	QR COUPLING

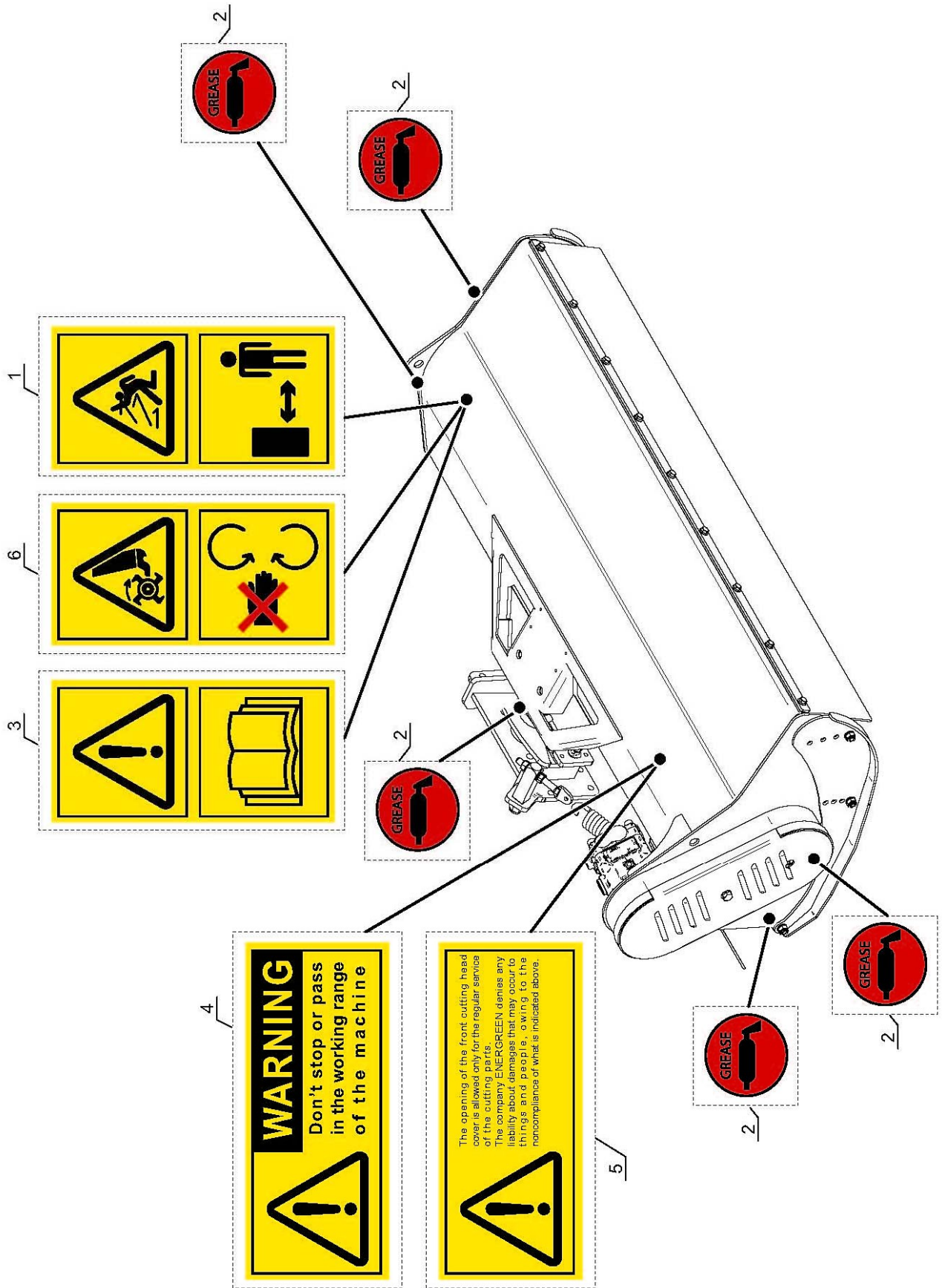

REF.	QTY.	PART No.	DESCRIPTION
1	1	4000768	DECAL KIT DECAL - THROWN OBJECT DANGER
2	5	4000769	GREASE POINT
3	1	4000770	SAFETY INSTRUCTIONS
4	1	4000771	WORK RANGE DANGER
5	1	4000772	OPENING DOOR
6	1	4000773	MOVING PARTS DANGER



McConnel Limited, Temeside Works, Ludlow, Shropshire SY8 1JL. England.
Telephone: 01584 873131. Facsimile: 01584 876463. www.mcconnel.com