

Publication 861
February 2017
Part No. 23671.61

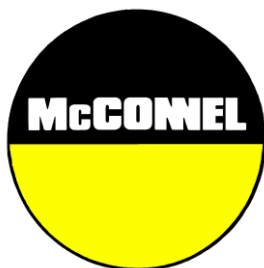

McCONNEL

ROBOMAX

80HP REMOTE CONTROLLED MOWER

Operation Manual

For Machines 02/15 to 09/17

Serial No. ROBOM021500001 ► ROBOM091700023



IMPORTANT

VERIFICATION OF WARRANTY REGISTRATION

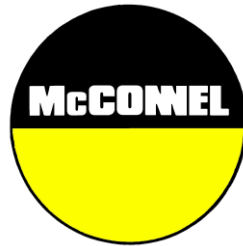

DEALER WARRANTY INFORMATION & REGISTRATION VERIFICATION

It is imperative that the selling dealer registers this machine with McConnel Limited before delivery to the end user – failure to do so may affect the validity of the machine warranty.

To register machines go to the McConnel Limited web site at www.mcconnel.com, log onto 'Dealer Inside' and select the 'Machine Registration button' which can be found in the Service Section of the site. Confirm to the customer that the machine has been registered in the section below.

Should you experience any problems registering a machine in this manner please contact the McConnel Service Department on 01584 875848.

Registration Verification

Dealer Name:
Dealer Address:
Customer Name:
Date of Warranty Registration:/...../..... Dealer Signature:

NOTE TO CUSTOMER / OWNER

Please ensure that the above section above has been completed and signed by the selling dealer to verify that your machine has been registered with McConnel Limited.

IMPORTANT: During the initial 'bedding in' period of a new machine it is the customer's responsibility to regularly inspect all nuts, bolts and hose connections for tightness and re-tighten if required. New hydraulic connections occasionally weep small amounts of oil as the seals and joints settle in – where this occurs it can be cured by re-tightening the connection – refer to torque settings chart below. The tasks stated above should be performed on an hourly basis during the first day of work and at least daily thereafter as part of the machines general maintenance procedure.

CAUTION: DO NOT OVER TORQUE HYDRAULIC FITTINGS AND HOSES

TORQUE SETTINGS FOR HYDRAULIC FITTINGS

HYDRAULIC HOSE ENDS		
BSP	Setting	Metric
1/4"	18 Nm	19 mm
3/8"	31 Nm	22 mm
1/2"	49 Nm	27 mm
5/8"	60 Nm	30 mm
3/4"	80 Nm	32 mm
1"	125 Nm	41 mm
1.1/4"	190 Nm	50 mm
1.1/2"	250 Nm	55 mm
2"	420 Nm	70 mm

PORT ADAPTORS WITH BONDED SEALS		
BSP	Setting	Metric
1/4"	34 Nm	19 mm
3/8"	47 Nm	22 mm
1/2"	102 Nm	27 mm
5/8"	122 Nm	30 mm
3/4"	149 Nm	32 mm
1"	203 Nm	41 mm
1.1/4"	305 Nm	50 mm
1.1/2"	305 Nm	55 mm
2"	400 Nm	70 mm

WARRANTY POLICY

WARRANTY REGISTRATION

All machines must be registered, by the selling dealer with McConnel Ltd, before delivery to the end user. On receipt of the goods it is the buyer's responsibility to check that the Verification of Warranty Registration in the Operator's Manual has been completed by the selling dealer.

1. LIMITED WARRANTIES

1.01. *All mounted machines supplied by McConnel Ltd are warranted to be free from defects in material and workmanship from the date of sale to the original purchaser for a period of 12 months, unless a different period is specified.*

All Self Propelled Machines supplied by McConnel Ltd are warranted to be free from defects in material and workmanship from the date of sale to the original purchaser for a period of 12 months or 1500 hours. Engine warranty will be specific to the Manufacturer of that unit.

1.02. *All spare parts supplied by McConnel Ltd and purchased by the end user are warranted to be free from defects in material and workmanship from the date of sale to the original purchaser for a period of 6 months. All parts warranty claims must be supported by a copy of the failed part invoice to the end user. We cannot consider claims for which sales invoices are not available.*

1.03. *The warranty offered by McConnel Ltd is limited to the making good by repair or replacement for the purchaser any part or parts found, upon examination at its factory, to be defective under normal use and service due to defects in material or workmanship. Returned parts must be complete and unexamined. Pack the component(s) carefully so that any transit damage is avoided. All ports on hydraulic items should be drained of oil and securely plugged to prevent seepage and foreign body ingress. Certain other components, electrical items for example, may require particular care when packing to avoid damage in transit.*

1.04. *This warranty does not extend to any product from which McConnel Ltd's serial number plate has been removed or altered.*

1.05. *The warranty policy is valid for machines registered in line with the terms and conditions detailed and on the basis that the machines do not extend a period of 24 months or greater since their original purchase date, that is the original invoice date from McConnel Limited.*

Machines that are held in stock for more than 24 months cannot be registered for warranty.

1.06. *This warranty does not apply to any part of the goods, which has been subjected to improper or abnormal use, negligence, alteration, modification, fitment of non-genuine parts, accident damage, or damage resulting from contact with overhead power lines, damage caused by foreign objects (e.g. stones, iron, material other than vegetation), failure due to lack of maintenance, use of incorrect oil or lubricants, contamination of the oil, or which has served its normal life. This warranty does not apply to any expendable items such as blades, belts, clutch linings, filter elements, flails, flap kits, skids, soil engaging parts, shields, guards, wear pads, pneumatic tyres or tracks.*

1.07. *Temporary repairs and consequential loss - i.e. oil, downtime and associated parts are specifically excluded from the warranty.*

1.08. *Warranty on hoses is limited to 12 months and does not include hoses which have suffered external damage. Only complete hoses may be returned under warranty, any which have been cut or repaired will be rejected.*

1.09. *Machines must be repaired immediately a problem arises. Continued use of the machine after a problem has occurred can result in further component failures, for which McConnel Ltd cannot be held liable, and may have safety implications.*

1.10. *If in exceptional circumstances a non McConnel Ltd part is used to effect a repair, warranty reimbursement will be at no more than McConnel Ltd's standard dealer cost for the genuine part.*

- 1.11. *Except as provided herein, no employee, agent, dealer or other person is authorised to give any warranties of any nature on behalf of McConnell Ltd.*
- 1.12. *For machine warranty periods in excess of 12 months the following additional exclusions shall apply:*
 - 1.12.1. *Hoses, exposed pipes and hydraulic tank breathers.*
 - 1.12.2. *Filters.*
 - 1.12.3. *Rubber mountings.*
 - 1.12.4. *External electric wiring.*
 - 1.12.5. *Bearings and seals*
 - 1.12.6. *External Cables, Linkages*
 - 1.12.7. *Loose/Corroded Connections, Light Units, LED's*
 - 1.12.8. *Comfort items such as Operator Seat, Ventilation, Audio Equipment*
- 1.13. *All service work, particularly filter changes, must be carried out in accordance with the manufacturer's service schedule. Failure to comply will invalidate the warranty. In the event of a claim, proof of the service work being carried out may be required.*
- 1.14. *Repeat or additional repairs resulting from incorrect diagnosis or poor quality previous repair work are excluded from warranty.*

NB Warranty cover will be invalid if any non-genuine parts have been fitted or used. Use of non-genuine parts may seriously affect the machine's performance and safety. McConnell Ltd cannot be held responsible for any failures or safety implications that arise due to the use of non-genuine parts.

2. REMEDIES AND PROCEDURES

- 2.01. *The warranty is not effective unless the Selling Dealer registers the machine, via the McConnell web site and confirms the registration to the purchaser by completing the confirmation form in the operator's manual.*
- 2.02. *Any fault must be reported to an authorised McConnell Ltd dealer as soon as it occurs. Continued use of a machine, after a fault has occurred, can result in further component failure for which McConnell Ltd cannot be held liable.*
- 2.03. *Repairs should be undertaken within two days of the failure. Claims submitted for repairs undertaken more than 2 weeks after a failure has occurred, or 2 days after the parts were supplied will be rejected, unless the delay has been authorised by McConnell Ltd. Please note that failure by the customer to release the machine for repair will not be accepted as a reason for delay in repair or submitting warranty claims.*
- 2.04. *All claims must be submitted, by an authorised McConnell Ltd Service Dealer, within 30 days of the date of repair.*
- 2.05. *Following examination of the claim and parts, McConnell Ltd will pay, at their discretion, for any valid claim the invoiced cost of any parts supplied by McConnell Ltd and appropriate labour and mileage allowances if applicable.*
- 2.06. *The submission of a claim is not a guarantee of payment.*
- 2.07. *Any decision reached by McConnell Ltd. is final.*

3. LIMITATION OF LIABILITY

- 3.01. *McConnell Ltd disclaims any express (except as set forth herein) and implied warranties with respect to the goods including, but not limited to, merchantability and fitness for a particular purpose.*
- 3.02. *McConnell Ltd makes no warranty as to the design, capability, capacity or suitability for use of the goods.*
- 3.03. *Except as provided herein, McConnell Ltd shall have no liability or responsibility to the purchaser or any other person or entity with respect to any liability, loss, or damage caused or alleged to be caused directly or indirectly by the goods including, but not limited to, any indirect, special, consequential, or incidental damages resulting from the use or operation of the goods or any breach of this warranty. Notwithstanding the above limitations and warranties, the manufacturer's liability hereunder for damages incurred by the purchaser or others shall not exceed the price of the goods.*
- 3.04. *No action arising out of any claimed breach of this warranty or transactions under this warranty may be brought more than one (1) year after the cause of the action has occurred.*

4. MISCELLANEOUS

- 4.01. McConnel Ltd may waive compliance with any of the terms of this limited warranty, but no waiver of any terms shall be deemed to be a waiver of any other term.*
- 4.02. If any provision of this limited warranty shall violate any applicable law and is held to be unenforceable, then the invalidity of such provision shall not invalidate any other provisions herein.*
- 4.03. Applicable law may provide rights and benefits to the purchaser in addition to those provided herein.*

McConnel Limited



DECLARATION OF CONFORMITY

Conforming to EU Machinery Directive 2006/42/EC

We,

McCONNEL LIMITED, Temeside Works, Ludlow, Shropshire SY8 1JL, UK

Hereby declare that:

The Product; *Radio Controlled Tracked Mower*

Product Code; *RMOW*

Serial No. & Date Type

Manufactured in; *Italy*

Complies with the required provisions of the Machinery Directive 2006/42/EC
The machinery directive is supported by the following harmonized standards;

- BS EN ISO 12100 (2010) Safety of machinery – General principles for design – Risk assessment and risk reduction.
- BS EN 349 (1993) + A1 (2008) Safety of machinery - Minimum distances to avoid the entrapment with human body parts.
- BS EN ISO 14120 (2015) Safety of machinery - Guards general requirements for the design and construction of fixed and movable guards.
- BS EN 4413 (2010) Hydraulic fluid power. Safety requirements for systems and their components.

McCONNEL LIMITED operates an ISO 9001:2008 quality management system, certificate number: FM25970.

This system is continually assessed by the;
British Standards Institution (BSI), Beech House, Milton Keynes, MK14 6ES, UK
BSI is accredited by UK Accreditation Service, accreditation number: UKAS 003.
The EC declaration only applies if the machine stated above is used in accordance with the operating instructions.

Signed *Responsible Person*
CHRISTIAN DAVIES on behalf of McCONNEL LIMITED

Status: *General Manager*

Date: *January 2018*



For Safety and Performance...

ALWAYS READ THE BOOK FIRST

McCONEL LIMITED

**Temeside Works
Ludlow
Shropshire
England**

**Telephone: +44 (0)1584 873131
www.mcconel.com**

▲ WARNING

Cancer and Reproductive Harm
www.P65Warnings.ca.gov

D960

Operating, servicing and maintaining this equipment can expose you to chemicals including gasoline, diesel fuel, lubricants, petroleum products, engine exhaust, carbon monoxide, and phthalates, which are known to the State of California to cause cancer and birth defects or other reproductive harm. To minimize exposure, avoid breathing exhaust, do not idle the engine except as necessary, service your vehicle in a well-ventilated area and wear gloves or wash your hands frequently when servicing your vehicle. Battery posts, terminals and related accessories contain lead and lead compounds, chemicals known to the state of California to cause cancer, birth defects or other reproductive harm. For more information go to www.P65Warnings.ca.gov. This website, operated by California's Office of Environmental Health Hazard Assessment, provides information about these chemicals and how individuals may be exposed to them.

- McCONNEL ROBOMAX -

CONTENTS

CHAPTER 1 - GENERAL DESCRIPTION

1.1 Preliminary information	9
1.2 Operator training	10
1.3 Instructions for use	10
1.4 Introduction	11
1.4.1 Manual updates	11
1.4.2 Copyright	11
1.5 Warranties	12
1.6 Responsibilities	12
1.7 Permitted uses	13
1.8 Improper or non-permitted uses	13
1.9 Running in and testing the machine	14

CHAPTER 2 - MACHINE CHARACTERISTICS

2.1 Description of the machine	15
2.2 Standards applied	15
2.3 Machine identification	17

CHAPTER 3 - SAFETY REQUIREMENTS

3.1 General safety standards	18
3.1.1 Fully understanding the machine	19
3.1.2 Wearing safety clothing	19
3.1.3 Warnings for checks and maintenance	19
3.1.4 Machine checks	20
3.1.5 Handling and transport	21
3.2 General requirements	22
3.2.1 Safety warnings	23
3.2.2 Safety requirements for road circulation	23
3.2.3 Operational safety	23
3.2.4 Safety requirements during use	24
3.2.5 Safety requirements for the hydraulic system	24
3.2.6 Location of the safety plates	25
3.2.7 Description of the safety plates	26
3.3 General safety rules	
3.3.1 Care and maintenance	28
3.3.2 Safety during refuelling and topping up	29
3.3.3 Fire extinguisher and first aid	29

3.4 Maintenance requirements	
3.4.1 Warning plates	30
3.4.2 Tools	30
3.4.3 Personnel	30
3.4.4 Works performed under the machine	31
3.4.5 Keeping the machine clean	31
3.4.6 Periodical replacement of the main safety components	31

CHAPTER 4 - TECHNICAL DATA

4.1 Technical characteristics	32
4.2 Standard overall dimensions	
4.2.1 Machine	34
4.3 Machine name	35

CHAPTER 5 - TERMINOLOGY

5.1 Definition of the terms used	37
----------------------------------	----

CHAPTER 6 - USE OF THE MACHINE

6.1 Preliminary checks	38
6.2 Checks to perform at the start of each working day	
6.2.1 General check for oil leaks	38
6.2.2 Oil level check	39
6.2.3 Check of chrome-plated parts	39
6.2.4 Check of the safety devices	39
6.3 Description of the remote control	40
Standard version	40
Pruning version	41
6.3.1 Control panel	42
6.4 Operating the machine	43
6.4.1 Starting the diesel engine	44
6.4.2 Moving the machine forwards and backwards (standard mode)	44
6.4.3 Moving the machine forwards and backwards (inverted mode)	44
6.4.4 Speed adjustment potentiometer	45
6.4.5 Steering	45
6.4.6 Steering bias control	45
6.4.7 Head height adjustment	46
6.4.8 Starting the cutting flails	46
6.4.9 Stopping the cutting flails	47
6.4.10 Diesel engine speed control	47
6.4.11 Opening the front guard	47
6.4.12 Reversible fan control	48

- McCONNEL ROBOMAX -

6.4.13 Optional	49
6.4.14 Optional	49
6.4.15 Turning off the diesel engine	49
6.4.16 S-KEY	50
6.5 LCD Display	
- Description / Home page	51
- Maintenance menu / Maintenance code	52
- Malfunctions	53
-Alarms	54
6.6 Faults	
6.6.1 Diesel engine	55
6.6.2 Electric circuit	56
6.6.3 Hydraulic system	56
6.7 Fuses and relays	
6.7.1 Control unit fuses and relays	57
6.8 How to attach equipment	59
6.9 Working with the machine	60
6.10 Control station - operator work area	61

CHAPTER 7 - TRANSPORT AND HANDLING

7.1 Loading and unloading for road transport	62
7.2 Machine towing	63
7.3 Using the manual control	64
7.4 Starting the engine using jump leads and auxiliary battery	65

CHAPTER 8 - STORAGE

8.1 Dismantling and decommissioning	66
-------------------------------------	----

CHAPTER 9 - MAINTENANCE

9.1 Introduction	68
9.2 General requirements	68
9.3 Extraordinary interventions	69
9.4 Lubricant and fluids tables	69
9.4.1 Fuel	70
9.5 Engine maintenance	
9.5.1 Engine oil	70
9.5.2 Coolant	70
9.5.3 Topping up the fuel	71
9.6 Maintenance of the hydraulic system	71
9.7 Maintenance of the electrical system	72
9.8 Periodical replacement of the safety components	73

- McCONNEL ROBOMAX -

9.9 Maintenance as required	
9.9.1 Check, cleaning or replacement of air filters	73
9.9.2 Inspection and external cleaning of the radiator	74
9.9.3 Replacing the track	75
9.10 Checks to perform at the start of every work day	76
9.10.1 Coolant level check	76
9.10.2 Fuel level check	77
9.10.3 Engine oil level check	77
9.10.3 Hydraulic oil level check	78
9.10.5 Drainage of fuel settling tank	79
9.11 Maintenance every 50 hours	
9.11.1 Track tensioning pressure check	80
9.11.2 Electrical system check	80
9.12 Maintenance after the first 50 hours	
9.12.1 Changing the engine oil and filter	81
9.13 Maintenance every 250 hours	
9.13.1 Changing the diesel engine oil and filter	81
9.13.2 Changing the diesel filter	81
9.14 Maintenance every 500 hours	
9.14.1 Changing the hydraulic oil	83
9.14.2 Changing the hydraulic oil filter	84
9.15 Maintenance every 1000 hours	
9.15.1 Replacing the coolant	85

CHAPTER 10 - INSTRUCTIONS FOR EMERGENCY SITUATIONS

10.1 Fire	86
-----------	----

<u>CHAPTER 11 - NOTES</u>	87
----------------------------------	----

- McCONNEL ROBOMAX -

1 - GENERAL DESCRIPTION

1.1 - PRELIMINARY INFORMATION

This use and maintenance manual complies with the Machinery Directive 2006/42/EC and subsequent amendments and integrations.

Do not destroy or modify it; any additions must be made by adding files.

Manual code: EITUM13000
Revision no.: 00 Edition: 11/2015
Machine type: Self-propelled horizontal axis flail mower
Model: RoboMAX

The manual is valid from the serial number:

ROBOM021500001

McConnel Limited
Temeside Works
Ludlow
Shropshire SY8 1JL
United Kingdom

Tel: + 44 (0)1584 873131
<http://www.mcconnel.com>

Annex list:

- Spare parts catalogue
- Equipment manual, if present
- Engine use and maintenance manual
- Remote control use and maintenance manual

- McCONNEL ROBOMAX -

1.2 - OPERATOR TRAINING

Read this manual thoroughly:

- all machine operators and maintenance personnel must read this entire manual thoroughly and pay maximum attention to its requirements.
- the employer has an obligation to ensure that the operator possesses the required abilities to operate the machine, and that they have read this manual fully.

1.3 - INSTRUCTIONS FOR USE AND STORAGE

The operating instructions contained in this manual are valid exclusively for the RoboMAX machine.

This instruction manual must be read and used as follows:

- The instructions manual is considered an integral part of the machine and must be read carefully.
- The instruction manual must be easily accessible to operators and maintenance technicians.
- Keep the manual for the entire lifetime of the machine.
- Ensure that any updates are incorporated in the text.
- Give the manual to any other user or subsequent owner of the machine.
- Use the manual in such a way as not to damage it.
- Do not remove, tear out or rewrite any part of the manual for any reason.
- Store the manual away from moisture and heat.
- In the event that the manual is lost, damaged or is in an unreadable condition, a new copy should be requested from the manufacturer.

Pay special attention to the symbols and meanings below; they are provided throughout the manual to highlight important operating information.

WARNING:

Refers to supplements or suggestions for correct use of the machine.

ATTENTION:



Refers to dangerous situations which can occur when using the machine, that could cause serious injuries or property damage.

DANGER:



Refers to dangerous situations which can occur when using the machine, which, if not avoided, could give rise to serious injuries or death.

1.4 - INTRODUCTION

The service instructions outlined in this manual represent an integral part of the machine supply contract.

These instructions are also addressed to operators already specifically trained to operate this kind of machinery and contain all information necessary and essential for safe operation and correct / optimal use of the machine. Rushed and incomplete preparations lead to improvisation, the cause of many accidents.

Read the following suggestions carefully and put them into practice before starting work:

- 1) Familiarise yourself and become confident with all permissible operations and positions before performing any manoeuvres.
- 2) The operator must always have the instruction manual available at all times.
- 3) Schedule all work with care.
- 4) Know in-depth where and how the machine is intended to be used: ground load capacity, movement restriction due to the presence of buildings, power lines and similar.
- 5) Before starting to work, ensure that the safety devices are working correctly and there are no doubts about their operation; if this is not the case, do not under any circumstances use the machine.
- 6) Carefully follow the warnings regarding specific hazards indicated in this manual.
- 7) Constant and thorough preventive maintenance always guarantees the highest possible operational safety of the machine. Never put off the necessary operations, and ensure they are performed exclusively by specialised personnel, using only original spare parts.

1.4.1 - MANUAL UPDATES

The information, the descriptions and the illustrations contained in this manual reflect the state of the art at the moment the machine was sold.

The manufacturer reserves the right to make modifications to its products at any time for technical or commercial reasons. In the event that such modifications are made, the manufacturer has no obligation (for safety reasons) to modify the other machines sold up to that point or send out updates to the manual. Moreover, this publication shall not be considered lacking in any way. Any supplements that the Manufacturer considers appropriate to supply at a later date must be kept together with the manual and considered an integral part of it.

1.4.2 - COPYRIGHT

The copyright of this manual belongs to the machine's manufacturer. This manual contains technical texts, drawings and illustrations which may not be divulged or transmitted to third parties, in whole or in part, without the written authorisation of the machine manufacturer.

- McCONNEL ROBOMAX -

1.5 - WARRANTIES

The parts supplied by McConnel are covered by a 12-month warranty, that becomes valid upon commissioning, proven by the documentation delivered to the customer.

McConnel shall repair or replace parts recognised as defective during the warranty period.

By replacing the defective part, McConnel shall consider itself absolved from any other expense borne by the Dealer and the Dealer's Customer, for instance;

presumed damages, either present or future, such as lost earnings, liquidated damages, etc.

Ordinary and extraordinary maintenance must be carried out in accordance with the instructions contained in this manual.

For all cases not included and for any type of support, McConnel must be contacted directly by registered letter or via fax, even in the event where a telephone agreement has already been made.

McConnel shall not be liable for any delays or unperformed operations.

McConnel shall not be responsible for any damage or malfunctions due to technical operations that have been carried out on the machine by unauthorised personnel.

1.6 - RESPONSIBILITIES

McConnel considers itself released from all responsibilities and obligations for accidents involving personal injury or property damage which may occur due to:

- Failure to observe the instructions given in this manual to run, operate and maintain the machine.
- Abrupt movements or incorrect manoeuvres when operating or performing maintenance on the machine.
- Modifications made to the machine without prior written authorisation from McConnel.
- Any other occurrence which should fall outside normal, correct use of the machine.

In any case, whenever the user blames the accident on a defect of the machine, it must be demonstrated that the consequent damage was a principal and direct consequence of such defect.

Any tampering with the machine or the use of non-original spare parts can be grounds for voiding the warranty and puts the operator's safety at risk.

ATTENTION:



Always use original spare parts for repairs and maintenance.

McConnel shall not be held responsible for any damage which should occur due to failure to follow the above requirements.

The machine is guaranteed according to the contractual agreements specified at the time of sale.

The warranty shall nevertheless lapse whenever the regulations and/or instructions laid out in this manual are not followed.

- McCONNEL ROBOMAX -

1.7 - PERMITTED USES

RoboMAX is a machine that has been built to be used by professional personnel, mainly to cut plants that are growing in, or located on, the ground such as grass, reeds, bushes and shrubs having a maximum stem diameter of 3 cm. Do not work with the flail head raised off the ground. Any other use shall be considered inappropriate, and the manufacturer shall not be held responsible for any damage to the machine or other property, or for injuries which may result. The machine is suitable for performing flail mowing operations at a speed of up to 4-5 km/h, depending on the conditions of the ground and the type and condition of material to be cut (length, whether dry or wet, density, etc.) and on slopes having a maximum inclination of 55°. It can be used for snow-covered ground or as a tool carrier. This machine is generally used during daylight hours. If, under exceptional circumstances, it has to be used at night or in conditions of reduced visibility, an auxiliary lighting system must be used. Always operate in daylight or with artificial lighting which guarantees visibility of at least 100 m.

1.8 - IMPROPER OR UNAUTHORISED USES

ATTENTION:



This section indicates some of the uses considered improper or otherwise not allowed; as it is impossible to foresee all possible improper uses, if a new requirement for using the machine occurs, seek advice from McConnell before attempting the work.

WARNING:

Instructions for the permitted optional accessories are given in the corresponding use and maintenance manuals. If this equipment is supplied by McConnell, these publications are supplied as an annex to this manual. Instructions for installing permitted equipment, controls requiring a provision on the machine, and the hydraulic attachments that are necessary for the equipment to operate are included in the final section of this manual.

The following uses must always and absolutely be avoided:

- Use of the machine by minors, inexperienced, untrained or unlicensed persons.
- Use of the machine to lift and/or transport persons or things.
- Use of the flail mower head as a piledriver.
- Use of the machine to tow damaged vehicles.
- Use of the machine to shred brushwood and shrubs with diameter greater than 3 cm.
- It must not be used on surfaces on which there is glass, gravel, iron parts or other foreign bodies that could be thrown into the air by the blades or damage the mower.
- Lifting or pulling loads.
- Putting the machine into contact with accessories or equipment classified as dangerous due to their chemical or physical properties (e.g. flammable, toxic, explosive, etc. materials).
- Overloading the machine beyond its permitted limits.
- Increasing the working length with equipment without prior authorisation from McConnell.
- The machine must not be used on public roads.

- McCONNEL ROBOMAX -

DANGER:



Using the machine as mentioned above can cause tipping hazards or structural failure that could result in injuries or even death.

1.9 - RUNNING IN AND TESTING THE MACHINE

Every machine is scrupulously adjusted and tested before delivery.

A new machine must however be used with caution for the first 100 hours, to carry out a good running-in of the various components.

If the machine is subjected to excessive work load at the beginning of its operation, its performance and its functionality will be prematurely jeopardised and reduced.

During the running-in period, pay great attention to the following points:

- After start-up, allow the engine to run at a low revs for 5-6 minutes.
- Avoid making the machine work to its limit for the first 100 hours of operation. Avoid any sudden accelerations or decelerations.

After the first 50 hours, apart from scheduled maintenance, carry out the following operations:

- engine oil change;
- engine oil filter change;
- fuel filter change;

After the first 250 hours, apart from scheduled maintenance, carry out the following operations:

- hydraulic system oil filter change;

ATTENTION:



During the replacement of the oil filters, inspect their internal parts to check for any deposits. If there are any, verify the possible cause before restarting the machine.

- McCONNEL ROBOMAX -

2 - MACHINE CHARACTERISTICS

2.1 - DESCRIPTION OF THE MACHINE

RoboMAX is a multi-purpose tool carrier suitable for various applications and tasks. The standard equipment includes four double-acting hydraulic functions. RoboMAX, designed to meet the most diverse needs, can be defined as a MULTI-PURPOSE remote controlled machine, that has power and performance comparable to that of a traditional agricultural tool carrier tractor.

Standard authorised equipment:

- Flail Mower (1.8m cutting capacity)
- Forestry Head (1.5m cutting capacity)

Contact McConnel for details of all attachments and equipment available for this machine.



ATTENTION:

It is prohibited to use interchangeable equipment not specified in the above list or any equipment not approved by McConnel.

McConnel declines all responsibility for damage of any kind caused by improper use or use other than that described above.

2.2 - STANDARDS APPLIED

This machine was designed and constructed in compliance with EC directives on safety and approximation of the laws of Member States, specifically the Machinery Directive 2006/42/EC, where applicable.

The following Standards were also taken into account during the machine's design:

- EN ISO 12100:2010 "Safety of machinery"
- ISO 4254-1:2013
- ISO 3767-1:1998
- ISO 11684:1995
- 2004/108/EC: Electromagnetic compatibility

- McCONNEL ROBOMAX -

2.3 - IDENTIFICATION OF THE MACHINE

The identification plate of the machine is affixed to the right-hand side of its frame, in the rear section of the right-hand side rail.

ATTENTION: The serial number and year of manufacture must always be stated when requesting assistance and/or ordering spare parts.

		CE	
DENOMINAZIONE-FUNZIONE DENOMINATION-FUNCTION	PORTATTREZZI RADIOCOMANDATO REMOTE-CONTROLLED EQUIPMENT CARRIER MACHINE		
NUMERO DI SERIE SERIAL NUMBER	ROBOMXXXXXXXXXX		
MODELLO MODEL		POTENZA MOTORE ENGINE POWER	28.2 kW
MASSA WEIGHT	1000 kg	ANNO FABBRICAZIONE MANUFACTURE YEAR	201

E113010913158



NOISE LEVEL

LpA = the value indicates the maximum sound level perceived by the operator at 1 m from the machine.

LpA
99

LwA = the value indicates the sound level outside the machine and refers to the noise perceived by those who are in the vicinity of the work area.

LwA
105

Standards EN ISO 3744:2010, EN ISO 11201:2010

ATTENTION:



Personal protective equipment must be worn when using the machine.



3 - SAFETY REQUIREMENTS

3.1 - GENERAL SAFETY STANDARDS

ATTENTION:



Adhesive information/warning plates have been affixed to the machine with the aim of making its use safer. For this reason, they must always be replaced immediately if they are damaged or become no longer legible.

Occasional operators must not be permitted to use this machine - it must only be operated by those who possess a level of experience with this type of equipment.

Whenever direct visibility of the work zone from the control station is not sufficient, the operator must be assisted by a specifically assigned person.

Check the condition and operation of any part subject to wear on a monthly basis: (pins, valves, piping, etc.). When necessary, replace with original genuine parts.

Do not tamper with the hydraulic system for any reason and never attempt to remove the seal from the valves, or any and all warranties shall lapse. Contact an authorised repair shop if the valves should require attention or adjustment.

Excessive heating of the hydraulic fluid can cause damage to the seals of the hydraulic circuit and deterioration of the fluid itself. Over heating can be caused by prolonged excess pressure in the hydraulic system; for this reason, avoid continuing to operate rams when they reach the end of their stroke.

It is also necessary to check that the machine emergency button and remote control stop button are working correctly.

ATTENTION: If the emergency or stop buttons are damaged or faulty the machine must not be started up and all operations must be ceased immediately. Do not attempt to use the machine again until the problem has been correctly addressed and the machine returned to full working order with all functions operating correctly.

The machine user is responsible for all property damage or personal injuries caused by machine operation.

Maintenance, cleaning, adjustments or similar operations on any part of the machine or attached equipment are strictly forbidden when the machine is running or moving. Maintenance, cleaning or adjustments of any kind must always be performed with the engine off and the key removed.

It is forbidden to remove or alter guards protecting moving parts or hot surfaces of the machine, or those on interchangeable equipment attached to the machine.

- McCONNEL ROBOMAX -

3.1.1 – FULLY UNDERSTANDING THE MACHINE

The machine must be used only by qualified personnel who are familiar with the location and the function of all its controls, tools, indicators, indicator lights and plates.

3.1.2 – WEAR SAFETY CLOTHING

Wear tight-fitting clothing and use safety equipment which meets applicable regulations.

During use, the machine may generate dust when working with dry materials (e.g. straw or on sections of bare ground). In this case, the use of appropriate respiratory protection, such as dust masks, is recommended.



3.1.3 – INSTRUCTIONS FOR CHECKS AND MAINTENANCE

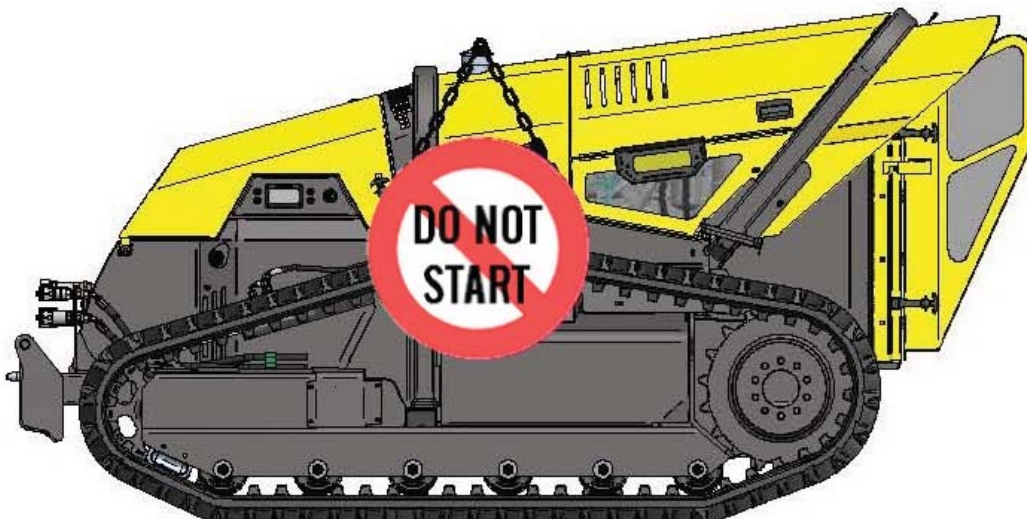

Apply a sign to the machine reading “DO NOT START”. Remove the key from the ignition before performing any checks or maintenance.

3.1.4 – MACHINE CHECKS

- Carefully inspect the machine every day before use, following the check-list stated in this manual.
- Only start the engine in well ventilated areas and ensure nobody is within the close proximity of the machine.
- Covers and safety devices must not be removed. They are designed and fitted to the machine for your safety and the safety of others.
- Do not use the machine if the safety devices or covers are damaged, missing or incorrectly fitted.
- Make sure that all safety devices are put back into place immediately after carrying out cleaning or repair work.
- Keep the machine and all its accessories clean and in good working order at all times, removing any cut materials that have been deposited on the machine.
ATTENTION: Fire danger!
- It is strictly prohibited to make any changes to the machine without prior authorisation from the manufacturer. Changes to the machine can cause hazards and injuries. - The manufacturer shall not be held responsible for the machine if these instructions are not followed.
- Only refuel when the machine is turned off, if possible before having turned it on, and with the fuel tank cold. If you need to refuel whilst work is in progress, do not add fuel to the tank if the tank is hot or if the engine is still warm. Allow the machine to cool down. **ATTENTION: Danger of explosion and fire!**
- During normal daily maintenance do not clean electrical components using high pressure water (pressure washer), this includes components such as;
 - receiver and remote control
 - actuator
 - fuse and relay box

Apply a guard or cover with appropriate means before cleaning.

- McCONNEL ROBOMAX -

3.1.5 – HANDLING AND TRANSPORT

WARNING:

Pay maximum attention to safety during loading and unloading operations, which must be performed by personnel qualified to use the corresponding equipment (slings, forklifts etc.). When lifting the machine, the specific lifting points indicated by the pictograms must be used.

Before commissioning, proceed as follows:

- Only lift the machine using suitable lifting equipment and ropes or chains with a suitable load capacity. Check the mass of the machine by referring to the “technical data” table in section 4.1 of this manual.
- Place the machine on a firm level surface.
- Remove any covers and/or guards.
- Start the engine (see chapter 6.4.1)



Sling Angle Factor - Example Diagrams

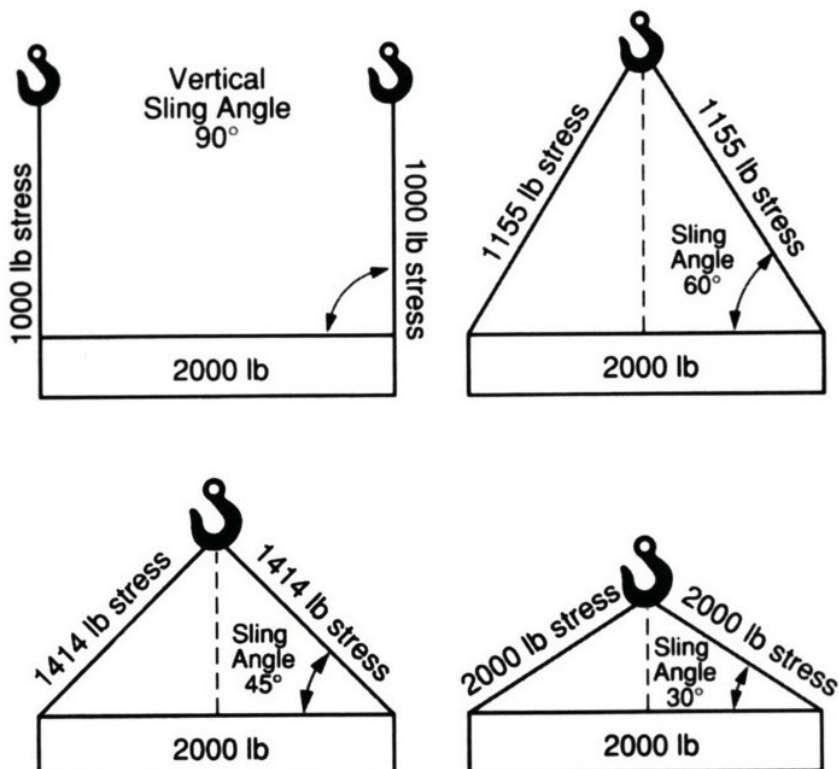

3.2 - GENERAL REQUIREMENTS

- It is mandatory to read and follow all the instructions stated in the use and maintenance section of this manual before performing any operation or manoeuvres with the machine. It is too late to do so while working. Improper use or an incorrect manoeuvre can result in serious damage to persons or property.
- The operators and maintenance technicians must know the machine well, in particular they must know all the dangers that can occur from incorrect use or repair.
- Before start-up, carry out all checks on the machine and equipment with regard to the following: functionality, safety standards and protections.
- Even during correct use of the machine; when the flail head is running stones or other objects can be thrown great distances. Therefore, no persons or animals should be within the range of danger. Pay extreme attention when working with the machine near roads, buildings or vehicles etc.
- Before beginning the work, always check the integrity of the machines tools and all guards; if they are damaged or missing, replace them before attempting to use the machine.
- Make sure that nobody can involuntarily start the machine during checks or repairs. Do not wear loose clothing.
- Never carry persons on the machine.
- Never carry persons on any equipment attached to the machine.
- Never approach the machine if the rotor has not fully stopped.
- Before each start up, make sure that there are no persons and/or animals in the vicinity.
- Work on flat, firm ground, avoiding banks or slopes with steep gradients (more than 55 °).
- Before leaving the machine, proceed as follows:
 - 1 - Park the machine on a firm flat surface.
 - 2 - Reduce the engine rpm before turning the engine off. Press the remote control red button and turn the ignition key to the "O" position.
 - 3 - Remove the ignition key and take the remote control with you.
- Immediately replace any lost or damaged safety warning/instruction decals.
- Never underestimate or ignore safety regulations.
- Keep the remote control in a safe location to avoid access by unauthorised persons or children.

—3.2.1 - SAFETY WARNINGS

The machine has been designed and constructed according to the current technical requirements in force with regard to mowing of grass, hedges, maintenance of green areas, of roadsides, slopes, canals, drainage of water, etc. Observe all the laws, dispositions, prescriptions, ordinances and all directives in force for such machines.

Only use the machine for the purposes specified in this manual and manoeuvre the machine with the utmost care and attention at all times. Perform all maintenance tasks and procedures at the required times to ensure you retain maximum performance, continuous operation, and ultimately a long lifespan for your machine.

—3.2.2 - SAFETY REQUIREMENTS - ROADS / HIGHWAYS

The manufacturer declines any responsibility for accidents that occur while using the machine which are due to the non-observance by the user, of laws, dispositions, prescriptions, and rules in force for machines used for the mowing of grass, hedges, maintenance of green areas, of roadsides, slopes, canals, drainage of water etc.

The machine is designed to work in normal weather conditions at a temperature ranging from - 20°C to +40°C. Therefore, it can only operate under these environmental conditions.

In regard to mowing duties on public roads, the user should seek advice from the local authority responsible for the area in question; local rules and regulations can vary and the need for their permission is likely to be required.

—3.2.3 - OPERATION SAFETY

The manufacturer cannot be held responsible in case of malfunction and damage if the machine:

- is used for purposes other than those for which it was intended,
- is not manoeuvred, started and maintained according to the instructions specified in the manual.
- is not periodically and constantly maintained as per the maintenance instructions or non-original parts are used on the machine.
- is modified or its equipment is replaced without the written authorisation of the manufacturer, especially if the efficiency of safety devices has been reduced or eliminated on purpose.
- is used outside the allowed temperature range of - 20°C to + 40°C.

3.2.4 - SAFETY REQUIREMENTS DURING USE

- Before using the machine, inspect the mowing area and remove any stones, sticks, glass, metal, wire, branches or any other objects that may cause damage or danger if they were to come into contact with flail mower and/or rotor.
- Avoid obstacles during machine operation. Do not use the machine near steep slopes, unstable terrain or areas where the machine is at risk of tipping over.
- When working, great care must be adopted to avoid any form of contact with immovable objects, such as drains, wells, curbs, guardrails, railway lines etc. These can damage the machine or break the tools, which could be ejected from the machine at a high velocity.
- If wires, cables, chains or other similar items should get caught in the rotor; stop immediately to avoid damage or a dangerous situation. Stop the rotation of the cutter, switch off the engine and remove the key. Extract items fouling the rotor using pliers, shears or some other suitable tool; do not attempt to remove the items with your hands. Safety gloves and eye protection must be worn.
- Do not continue work if abnormal head vibrations are experienced; stop machine immediately and ascertain the cause, only resume work when the problem has been eliminated. Failure to observe this may cause serious damage to machine components.
- During operation take care when working beneath electrical cables; you may lose the radio signal as you pass under them, in which case the machine immediately switches off the engine and stops.
- Ensure that no persons are within a 10-metres radius of the machine before attempting to raise or lower the mounted equipment using the lifting device.

DANGER:



Do not attempt to free a 'fouled' rotor by reversing its direction of rotation.
Danger; risk of ejected materials.

3.2.5 - SAFETY REQUIREMENTS FOR THE HYDRAULIC SYSTEM

- Stop the machine immediately if an oil leak is detected.
- Periodically check hoses; replace immediately if they are found to be worn or damaged.
- Before working on the system lower the head to the floor (or any other mounted equipment) then turn off the engine and remove the starting key.
- Oils and greases must be disposed of in accordance with anti-pollution laws and regulations.

WARNING:

Do not look for oil leakages with your bare hands or other parts of your body. Use paper or rags to identify the leak. Always wear waterproof safety gloves and goggles.
Wait for the oil to cool down before performing any maintenance work.
Bleed out the oil pressure before disconnecting pipes or during maintenance of the system.
High pressure oil could penetrate the skin and cause serious infections. If this happens, consult a physician immediately.
These operations must only be performed by authorised personnel.

- McCONNEL ROBOMAX -

3.2.6 - LOCATION OF SAFETY DECALS

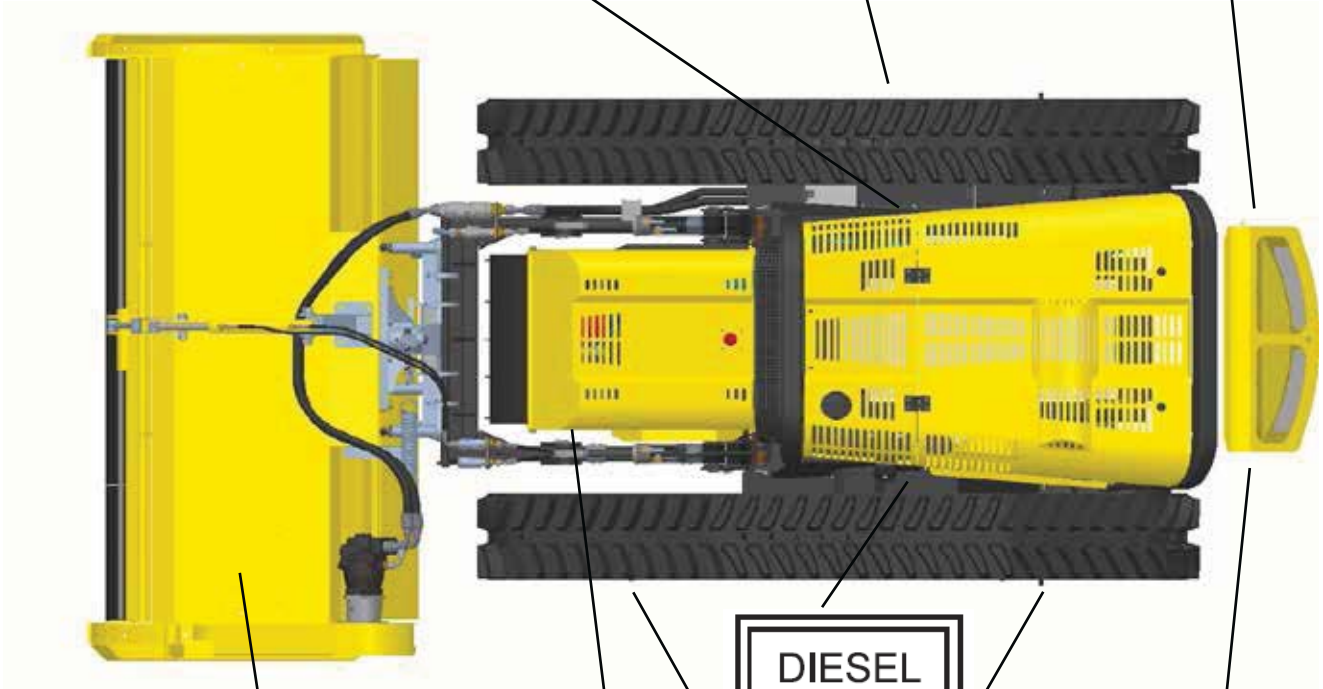
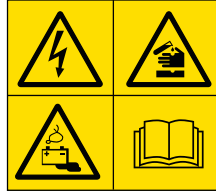

- McCONNEL ROBOMAX -

3.2.7 - DESCRIPTION OF SAFETY DECALS

WARNING:

Ensure safety decals are kept in good readable condition. If decals are damaged, they must be replaced immediately with original decals requested from the manufacturer and replaced in the same position as indicated in the manual.

Make sure safety decals are kept readable; clean them using a cloth dipped in mild soapy water.

a

Rotating tools hazard warning: Keep limbs clear of rotating components when the machine is running.

Flying objects hazard warning: this indicates the possibility that stones or other objects may be thrown from the machine, and requires people to stay out of its working radius.

Crushing or cutting danger: Do not place limbs in, or close to, any moving parts of the machine or the associated equipment attached to the machine.



b

Prohibition sign: Do not wash electrical parts with high pressure water; such as:

- fuse box
- receiver
- actuator

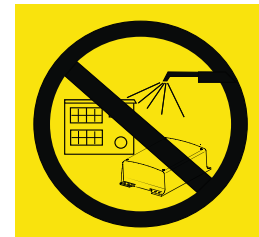

c

Machine handling: Lift point locations.

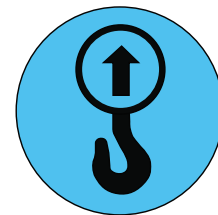

d

Emergency stop button.

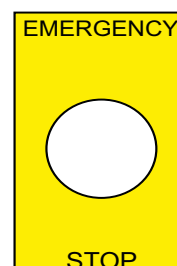

- McCONNEL ROBOMAX -

e Hydraulic oil tank



f Fuel tank



g Moving parts danger warning signs: indicates the presence of moving mechanical parts.

Do not lubricate: indicates that it is strictly forbidden to lubricate parts when machine is running; engine must always be switched off.



h Danger, hot components warning: indicates the presence of hot components on the machine, such as the silencer and bonnets.

Do not touch the areas around the sign.

BURN HAZARD



i Hazards associated with the battery:
Keep sparks, lighted matches, and open flame away; battery gas can explode.
Never check the charge of the battery by connecting the two poles with a metal object; use an acidimeter or a voltmeter.

Do not charge a frozen battery; danger of causing an explosion! First, warm the battery to 16°C and keep it in a place that has a temperature of 18°C.



Personal protective equipment:

All operators and personnel should be provided with appropriate personal protective equipment (PPE).



3.3 - GENERAL SAFETY RULES

3.3.1 - CARE AND MAINTENANCE

The cause of damage and accidents can often be attributed to mistakes or lack of maintenance, such as:

- Lack of oil, grease and anti-freeze.
- Lack of cleaning.
- Emergency Stop, limit switches not checked daily,
- Failure in the hydraulic system (damaged hoses, loose connections, etc.).

Carry out all service and maintenance work carefully; it is vitally important for both your safety and the safety of others - never put off repairs.

Assign only specialised or authorised personnel to carry out repairs.

Always follow the safety instructions given below, even if you are fully familiar with all the controls.

- Adapt the speed to the conditions of the travel path.
- Before starting to work, check that all the movements, limit switches, and safety devices operate properly.
- Check that the emergency stop devices are in perfect working order (on the remote control and on the machine).
- Continually ensure that nobody is within the danger zone of the machine (100m). Warn them by sounding the horn or verbally instruction and stop working if they fail to leave the danger zone.
- Do not allow anyone to climb onto the machine.
- Do not use the machine to lift or transport persons.
- ATTENTION: Due to normal machine vibration during operation, regular checks of all screw type connections should be performed, and where necessary, firmly retightened. This check must be carried out for the first time after an initial 8 hours of operation. Check also that all fastenings on the mower blades are secure and tightened correctly.
- If for any reason the flail rotor starts to vibrate, stop the machine immediately and restore the rotor balance. McConnell decline all responsibility for injuries to people or damage to property caused by the operator's failure to comply with these instructions.
- Clean the machine after use. Do not use petrol or solvent-based products to clean the machine.
Do not clean electrical parts with high pressure water.
- During operation, and in particularly windy conditions, the user must choose his operating position carefully in order not to be exposed to exhaust gases, dust or mown grass.
- Do not operate the machine if you are unable to clearly see it (behind ridges, corners of buildings, in tall grass etc.) Only operate the machine when you have a clear unobstructed view of the whole work area.

- McCONNEL ROBOMAX -

—3.3.2 - SAFETY DURING REFUELLING AND TOPPING UP

Fuel, oil and some types of anti-freeze are highly flammable.

Keep away from naked flames.

Turn off the engine and do not smoke when fuelling up.

Fuel up only when the engine is off and the machine is located in a well-ventilated area.

Do not allow unauthorised persons near whilst fuelling.

When fuelling up, hold the dispenser nozzle in the tank firmly and ensure it is in contact with the filler neck at all times until fuelling is complete to avoid the risk of sparks due to static electricity.

When filling up is complete, replace and tighten filler cap.

Do not fill the tank up fully; leave some space for the fuel to expand.

Immediately dry off any fuel that may have accidentally spilled.



—3.3.3 - FIRE EXTINGUISHER AND FIRST AID

Be prepared to face emergency situations.

Be prepared to face a fire.

Keep a fire extinguisher and a first aid kit within reach.

Keep emergency phone numbers near the telephone:
i.e. physicians, ambulance, hospital and fire brigade.

WARNING:

The machine's owner is responsible for the supply of a suitable fire extinguisher and first aid kit.

3.4 - MAINTENANCE REQUIREMENTS

3.4.1 - WARNING PLATES

Before performing any maintenance operation, position the machine on a firm level site with any attached equipment lowered fully to the ground, switch off the engine and remove the ignition key. If other persons were to start the engine and use the control levers while maintenance is performed, there is a risk of serious injuries or death. To prevent these hazards, before performing any service or maintenance work, place warning signs on the machine. If necessary, for added safety, additional warning signs can be placed around the perimeter of the machine.



3.4.2 - TOOLS

Only use good quality tools, specifically designed for the task; to prevent the risk of personal injury never use low quality or makeshift tools. Discard worn or damaged tools.

ATTENTION:



Use of incorrect or modified tools for specialized tasks that are used without prior authorisation from the manufacturer will release the manufacturer from any form of responsibility for damage to persons and/or property.

3.4.3 - SERVICE PERSONNEL

The routine maintenance indicated in the manual must only be performed by authorised and trained personnel. For maintenance or overhaul of components not specified in this manual; please contact the McConnel Service Department on +44 (0)1584 875848.

- McCONNEL ROBOMAX -

3.4.4 - WORKS PERFORMED UNDER THE MACHINE

Make sure the machine is raised and safely supported on a suitable level hard standing site before making any attempt to work beneath it. Ensure the appropriate tools required for the work are close to hand before starting the required maintenance task. To raise the machine off the ground, use the dedicated sling points on the carriage and attach the lifting gear using suitable wire ropes or chains (see paragraph 7.1: lifting & handling instructions). Position machine onto suitable horizontal stands.

NEVER PLACE YOURSELF UNDER AN UNSUPPORTED MACHINE

DANGER:



Do not climb on or get under the machine when it is raised and not properly supported as indicated in the safety standards. Ensure that any lifting gear, cables and/or chains used for raising the machine is rated with a minimum safe lifting capacity of over and above the maximum weight of the machine and any equipment that may be attached.

3.4.5 - KEEPING THE MACHINE CLEAN

- Regularly remove all flammable materials (i.e. dry grass, leaves etc.) from the areas around the exhaust pipe, engine, battery and any other locations where they may come into contact with oil or fuel that could cause them to ignite.
- Clean the machine after use. Do not use petrol or solvent-based products to clean the machine.
Do not clean electrical parts with high pressure water.

3.4.6 - PERIODICAL REPLACEMENT OF COMPONENTS

Check the following components periodically (for reasons of fire prevention and safety):

- supply system: fuel delivery and return pipes.
- hydraulic system: main delivery pipes to the hydraulic pumps.
- hydraulic system: pipes for utilities from the control valve to the hydraulic cylinders.

Even if they appear to be in good condition, hydraulic hoses must be replaced periodically as they will deteriorate with time. If hydraulic hoses shows signs of being defective, they must be replaced immediately; even if they are not past their expiry date.

- McCONNEL ROBOMAX -

4 - TECHNICAL DATA

4.1 - TECHNICAL CHARACTERISTICS

TOTAL WEIGHT

Total weight (without equipment)	1940 Kg.
Total weight with 280 mm rubber tracks and head	2600 Kg.

ENGINE

Make	YANMAR	Type	4TNV98T-ZXNDI
No. cylinder	4	Displacement	3319 cc 2500 rpm
Power	55 kW/80 Cv.	Max. torque	280 Nm @ 1700 rpm
Cooling	with fluid	Air filter	dry

ELECTRICAL SYSTEM

Voltage.....	12 VDC
Alternator	40 Amp.
Battery	18 Ah

HYDRAULIC SYSTEM

Transmission: 1x Tandem variable displacement piston pump in closed circuit;
maximum flow rate 57 l @ 300 bar.

Cutting head: 1x Variable displacement piston pump in closed circuit;
maximum flow rate 80 l @ 290 bar.

Services: 1x Gear pump;
maximum flow rate 17 l @ 180 bar.

TRANSFER SPEED

MOTION	FORWARD		REVERSE	
	1 (Slow)	2 (Fast)	1 (Slow)	2 (Fast)
Km/h @ 2500 rpm	4	7	4	7

- McCONNEL ROBOMAX -

TRACKS

MODEL	WEIGHT
RUBBER BELT TRACK 280/72/64	110 Kg.
RUBBER BELT TRACK 320/72/64	140 Kg.

CAPACITIES

Fuel Tank Capacity:	55 Litres
Hydraulic Oil Tank Capacity:	70 Litres
Diesel engine oil:	11 Litres
Coolant:	11 Litres

- McCONNEL ROBOMAX -

4.2 - STANDARD OVERALL DIMENSIONS

4.2.1 - MACHINE

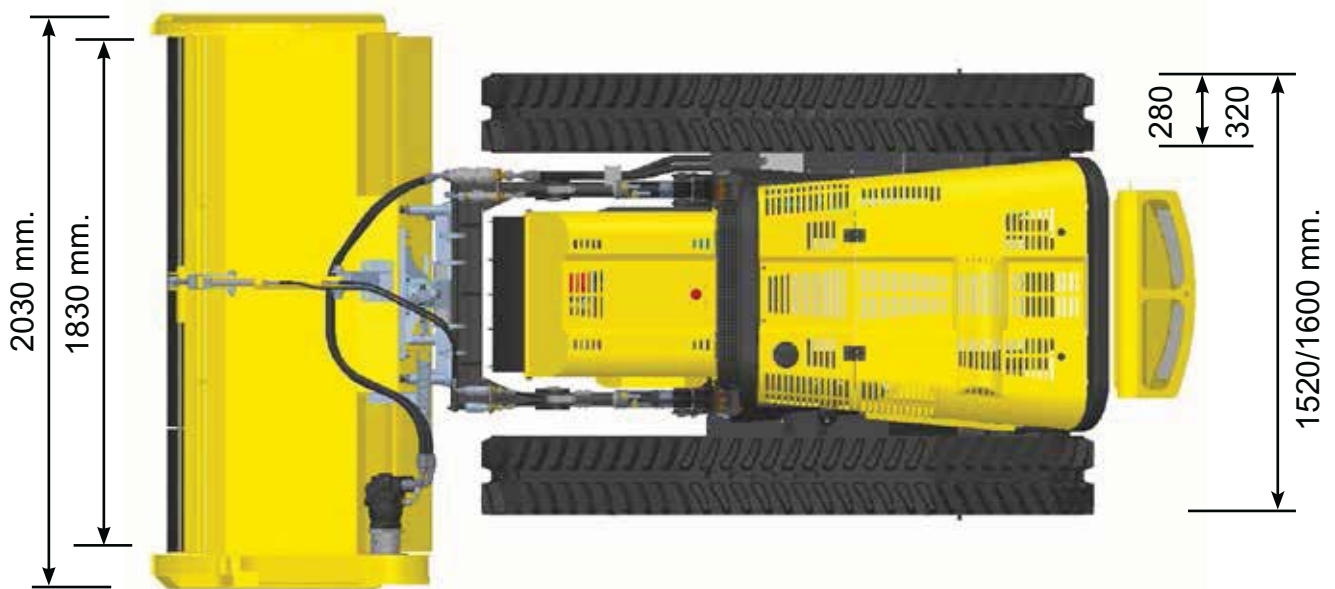
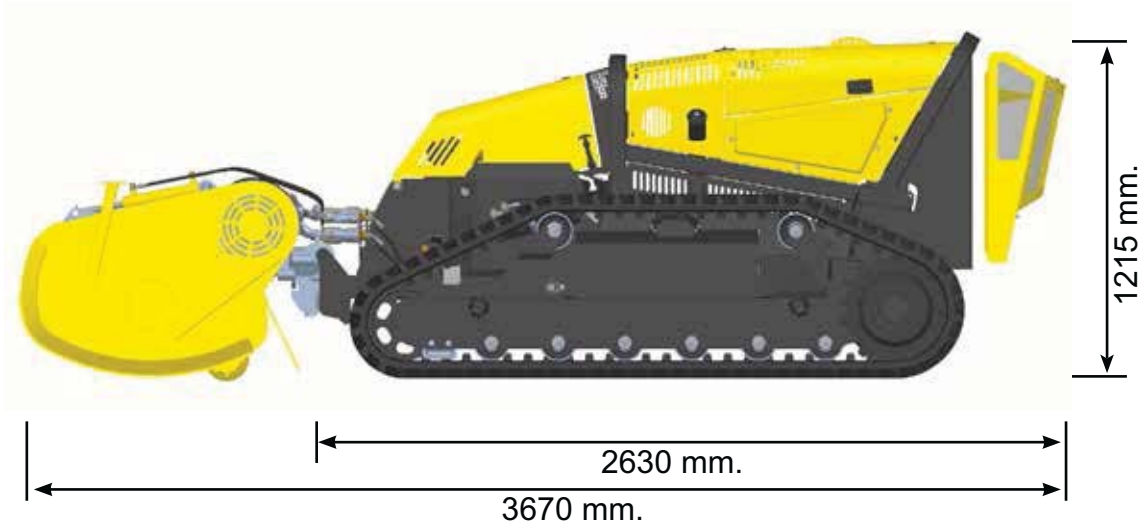

- McCONNEL ROBOMAX -

4.3 - MACHINE COMPONENTS

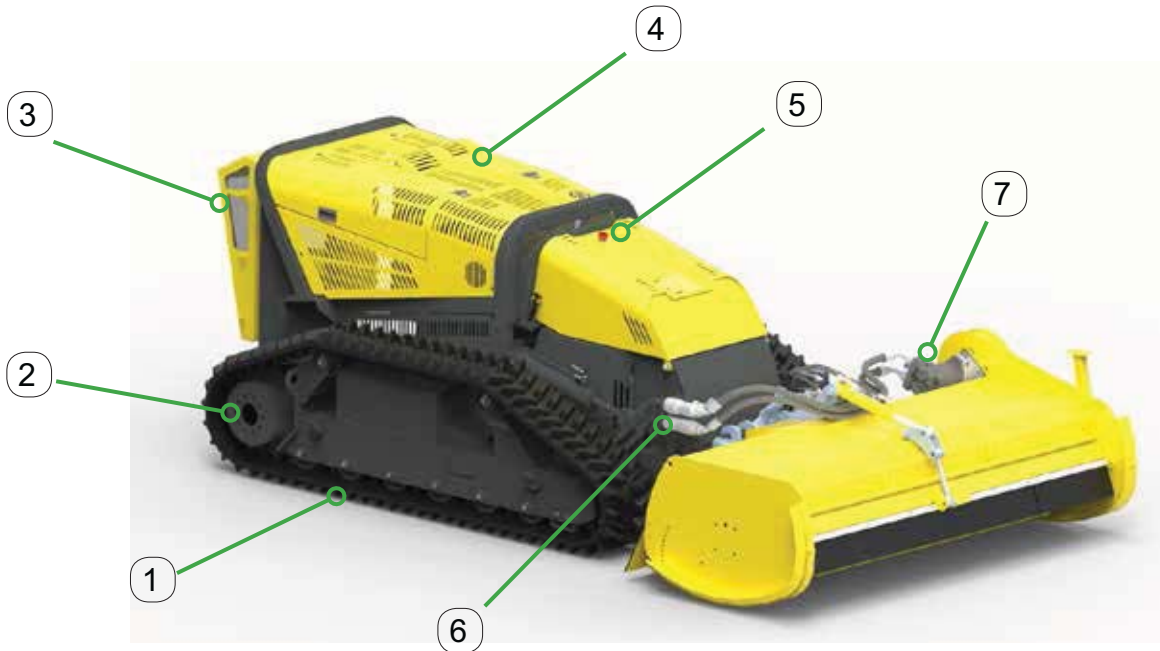

Right side view

- 1. Right track
- 2. Wheel drive
- 3. Radiator air vent
- 4. Bonnet

- 5. Stop button
- 6. High pressure quick couplings (closed circuit)
- 7. Cutting head hydraulic motor

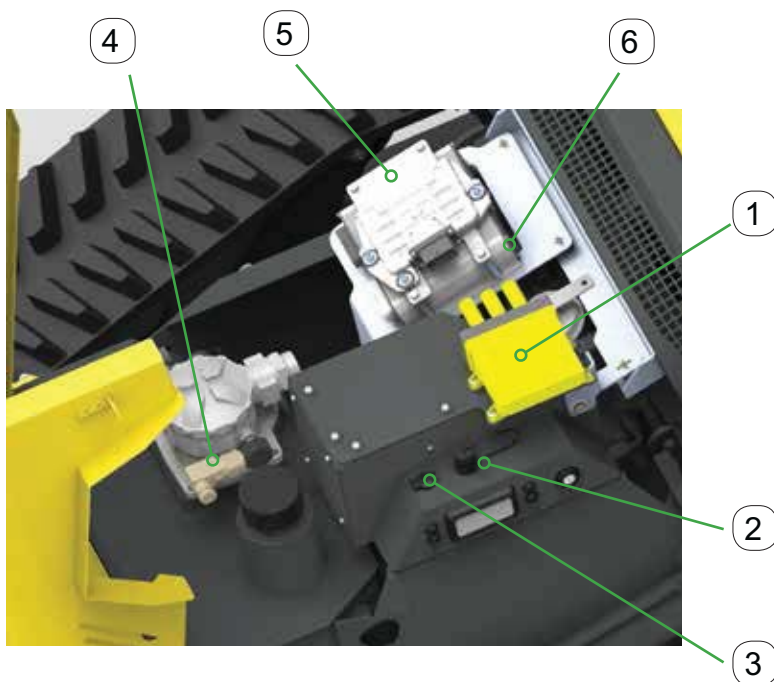

Control units

- 1. CANBus receiver
- 2. Wired remote control connector
- 3. 12 VDC power outlet
- 4. Filter clogging sensor
- 5. Diesel engine CPU
- 6. Control unit LE70

- McCONNEL ROBOMAX -

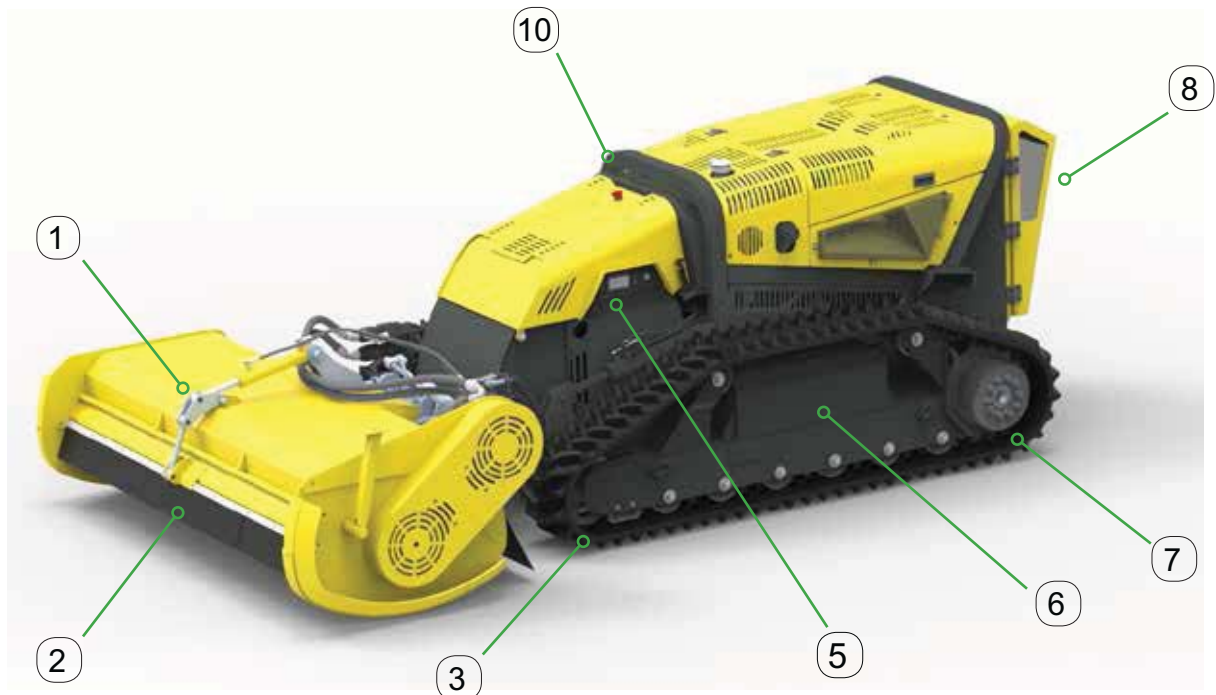

Left side view

- 1. Hydraulic cylinder, front guard opening
- 2. Front cutter guard
- 3. Left hand side rubber track
- 4. Hydraulic oil tank
- 5. Control panel
- 6. Diesel tank
- 7. Left hand side wheel drive

- 8. Radiator air vent and guard
- 9. Diesel tank cap
- 10. Roll bar
- 11. Engine air filter
- 12. Hydraulic oil/water radiator
- 13. Hydraulic oil filter

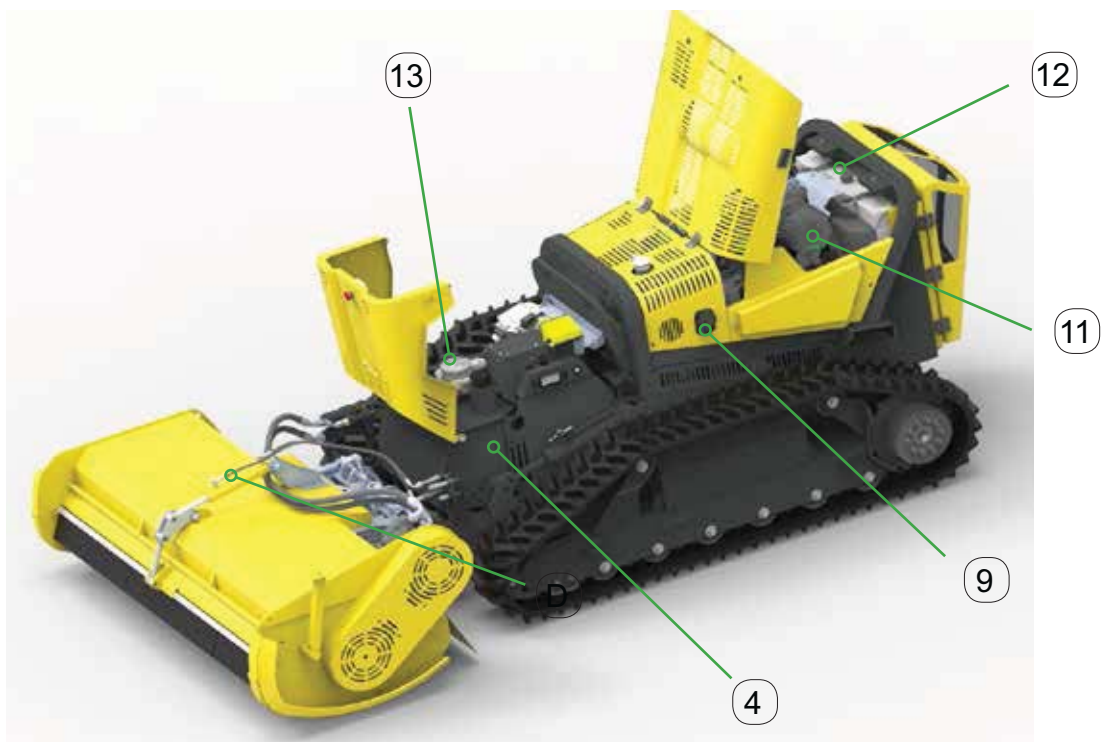

5 - TERMINOLOGY

5.1 - DEFINITION OF THE TERMS USED

OPERATOR

Personnel trained to manoeuvre the machine to perform work, movement and trained to carry out ordinary checks and cleaning on the machine. All operators must be fully competent and physically capable of safely using a machine of this type without putting themselves, or any others, at risk.

SPECIALISED OR MAINTENANCE PERSONNEL

Personnel trained to carry out operations of extraordinary maintenance, assembly, disassembly and reassembly of the machine's components, must be physically capable and not suffer from any kind of health problems that may affect their ability.

AUTHORISED PERSONNEL

Personnel trained to carry out operations of extraordinary maintenance, mounting, disassembly and reassembly of particular machine components;

- Must be authorised in by McConnel to intervene on the machine.
- Must be physically capable and not suffer any kind of health problems that may affect their ability.

OPERATOR ASSISTANT

Personnel trained to help the operator in any manoeuvre of the machine (i.e. manoeuvres on a work site where reduced visibility exists, loading and unloading the machine from a transporter, use of the manual control system.) and for activities on or near public highways, must have a full understanding of all work safety requirements.

AUTHORISED REPAIR WORKSHOP

Authorised repair workshop made up by personnel trained to carry out operations of extraordinary maintenance, mounting, disassembly and assembly of machine components must be authorised by McConnel to intervene with the machine.

The operator should refer to the Standard EN ISO 12100 : 2010 for the definition of the other terms used.

- McCONNEL ROBOMAX -

6 - USE OF MACHINE

6.1 - PRELIMINARY CHECKS

The operator must verify that the machine has been supplied with:

- Use and maintenance manual,
- Check register (if required),
- Policy liability insurance (if required).

In cases of resale of the machine, the customer/user must provide the buyer with a intact copy of a use and maintenance manual; if required, replacement copies are obtainable from McConnel.

The machine is provided with two sets of keys (ignition and bonnet); one set should be given to the operator and the other set must be kept in a safe location by the person responsible for operations (not kept on the machine), the spare keys should be readily available for all emergency situations.

6.2 - CHECKS TO PERFORM AT THE START OF EACH WORKING DAY

6.2.1 - GENERAL CHECK FOR OIL LEAKS

Carry out an external inspection of the machine (joints, hoses, hydraulic components, etc.) checking for any leaks of oil or other liquids.

Check the machines rubber hoses for any signs of wearing, cuts, holes, leakages, etc.

WARNING:

Do not look for oil leakages with your bare hands or other parts of your body. Use paper or rags to identify the leak.

Always wear waterproof gloves and safety goggles.



- McCONNEL ROBOMAX -

—6.2.2 - OIL LEVEL CHECK

Check that the engine oil level is within the correct limits.



Check that the hydraulic oil level in the tank is within the correct limits.



—6.2.3 - CHECKS OF CHROME-PLATED PARTS

Carry out an inspection of the chrome-plated ram rods to check that they are not scratched, pitted or damaged. Replace them if damaged.

—6.2.4 - CHECK OF SAFETY DEVICES

Check the safety devices installed on the machine are working properly, especially the emergency stop buttons on the machine and on the remote control. Also check the integrity of all the safety guards installed on the equipment (refer to the manual for the specific equipment).

ATTENTION:



If any components stated above malfunction or have a fault of any kind; do not attempt to use the machine under any circumstance - contact specialised repair personnel and report the problem. Do not use the machine again until the cause of the problem has been addressed and permanently fixed.

- McCONNEL ROBOMAX -

6.3 - DESCRIPTION OF THE REMOTE CONTROL

STANDARD VERSION



- A. Left joystick forward/reverse control
- B. Right joystick left/right steering and tool raise/lower control
- C. Stop button
- D. Forward speed control potentiometer
- E. Right/left direction adjustment potentiometer
- F. Reversible fan control
- G. Joystick inversion control
- H. Transfer speed selection control
- I. Mounted tool direction of rotation pre-setting control
- L. Tool rotation speed potentiometer
- M. Front guard control
- N. Optional
- O. AUX 1
- P. Engine stop button
- Q. Engine start button
- R. Increase engine speed button (+)
- S. Decrease engine speed button (-)
- Start Remote control/receiver connection search button
- S-key Coded key (S-key)

- McCONNEL ROBOMAX -

PRUNING VERSION



- A. Left joystick forward/reverse control
- B. Right joystick left/right steering and tool raise/lower control
- C. Stop button
- D. Forward speed control potentiometer
- E. Right/left direction adjustment potentiometer
- F. Reversible fan control
- G. Joystick inversion control
- H. Transfer speed selection control
- I. Mounted tool direction of rotation pre-setting control
- L. Tool rotation speed potentiometer
- M. Front guard control
- N. Optional
- O. Tool hydraulic motor control.
- P. Engine stop button
- Q. Engine start button
- R. Increase engine speed button (+)
- S. Decrease engine speed button (-)
- Start Remote control/receiver connection search button
- S-key Coded key (S-key)

- McCONNEL ROBOMAX -

6.3.1 - CONTROL PANEL

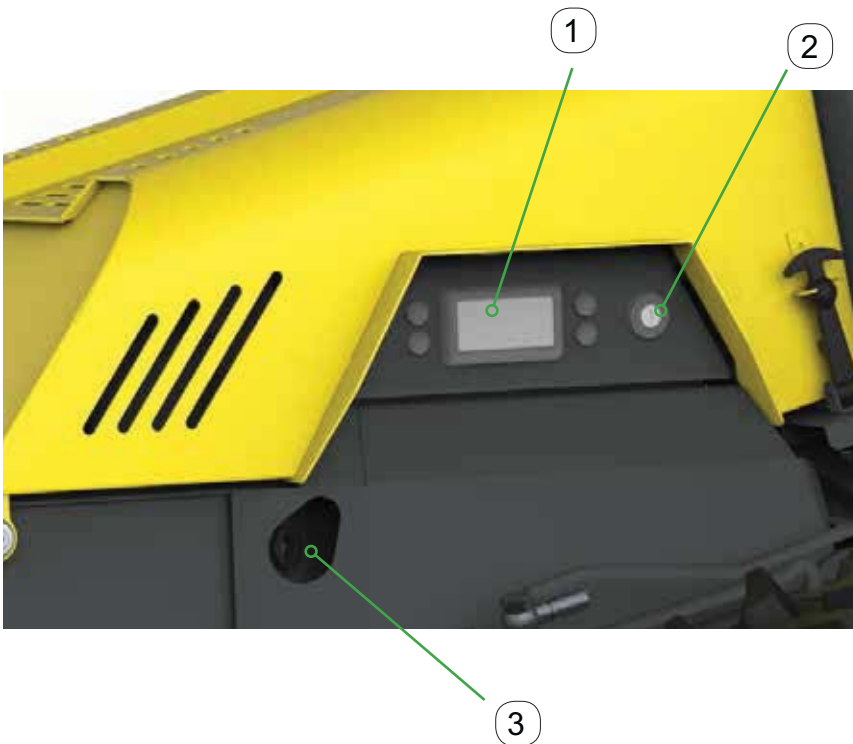

Control Panel

1. Display
2. Ignition switch
3. Hydraulic oil level sight gauge

LCD Display - CANBUS

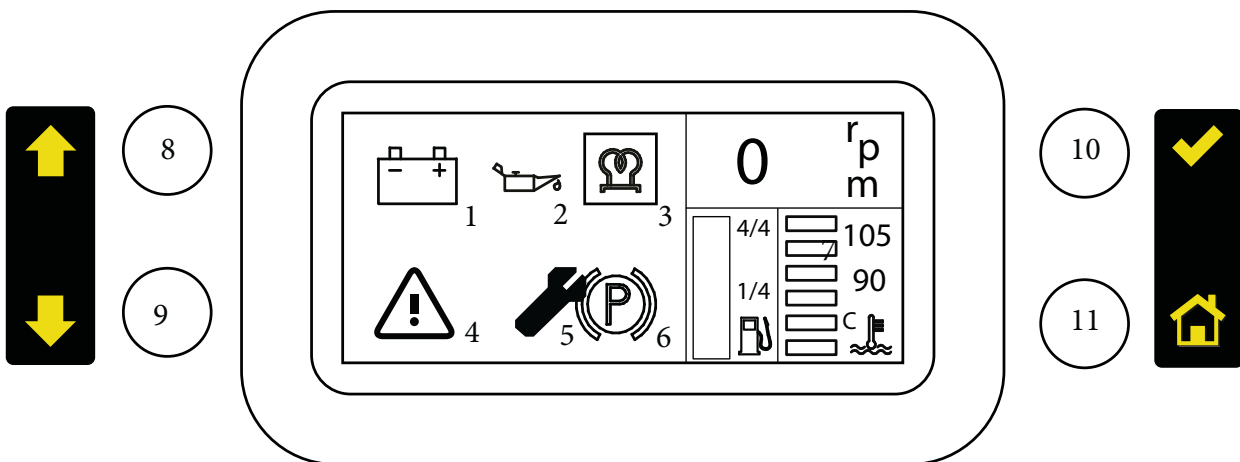

- | | |
|------------------------------------|--------------------------|
| 1. Alternator | 8. Page up |
| 2. Low engine oil pressure | 9. Page Down |
| 3. Glow plug preheating (optional) | 10. Enter key |
| 4. Engine stop | 11. Home Key (home page) |
| 5. Maintenance | |
| 6. Handbrake | |
| 7. Water temperature | |

- McCONNEL ROBOMAX -

6.4 - OPERATING THE MACHINE

ATTENTION:



Before starting up the machine, the information and safety instructions in this user manual must be read and fully understood. Operators of this machine must be fully instructed and trained. Familiarise yourself with the controls before starting operation.

DANGER:



DO NOT take drugs or drink alcohol before or while using the machine and tools. The use of drugs and alcohol can affect responsiveness and coordination, and therefore greatly impair their capability to use the equipment safely. Before using the machine or equipment, any operators who are on medication must consult a physician in regard to the possible side effects of their prescribed drugs as these may impair their capability to use the equipment safely. NEVER consciously allow anyone to use the machine when their attention or coordination is compromised; this could result in serious injuries or death of the operator and/or third parties.

6.4.1 - STARTING THE DIESEL ENGINE

- Observe safety instructions.
- Check the level of diesel; fill up if necessary.
- Start the machine outdoors only, never indoors where there is a risk of being poisoned by the exhaust fumes.
- Enable ignition by turning the ignition key towards the right. Wait for a few seconds for the active functions to be checked and then start the engine using the key or the remote control.



ATTENTION:

If the engine is started using the key it is no longer possible to connect to the remote control.

- Activate the remote control by turning the stop switch (I) to the right; it will spring outwards.

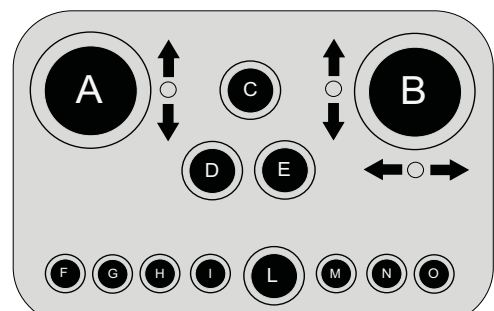

- McCONNEL ROBOMAX -

- Connect the remote control and the receiver by pressing the green “Start” button.
You will hear an acoustic signal (horn) confirming that the connection has been established and it is then possible to check that:
 - the green indicator light flashes slowly on the remote control.
 - the **POWER** indicator light flashes on the receiver.
 - the **RUN** indicator light flashes quickly on the receiver.
- Press button (Q) and the engine will start.

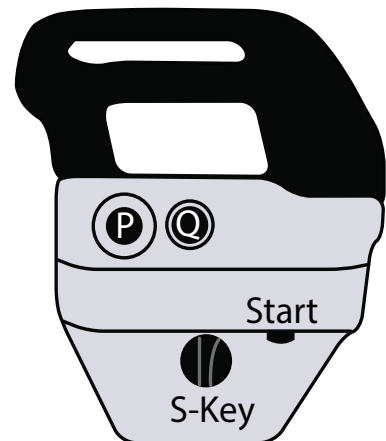

ATTENTION:



The starter motor must only be operated continuously for a maximum of 30 seconds. Trying to start the engine for too long will damage the starter motor. Burnt out starter motors are not covered by the warranty.

—6.4.2 - MOVING THE MACHINE FORWARDS AND BACKWARDS (STANDARD MODE)—

To move the machine forwards and backwards move the left hand side joystick (A) forwards and backwards. It is a proportional control so the more you move the joystick the faster the machine moves. The maximum speed that can be reached is determined by the position of the potentiometer (D) and the gear selected (H).

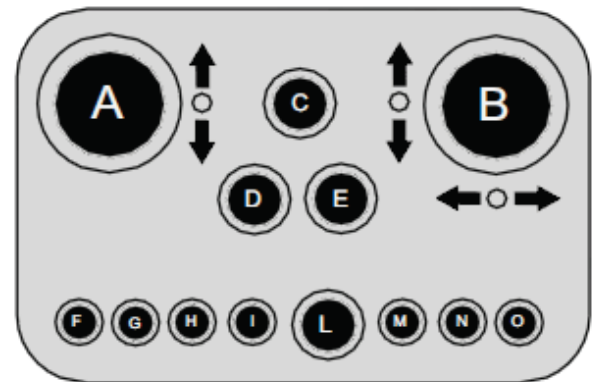

—6.4.3 - MOVING THE MACHINE FORWARDS AND BACKWARDS (INVERTED MODE)—

If switch (G) is activated the functions of joystick (A) will be inverted.

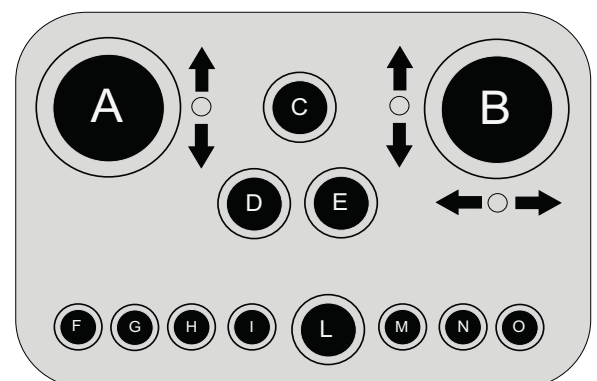

- McCONNEL ROBOMAX -

— 6.4.4 - SPEED ADJUSTMENT POTENTIOMETER —

The potentiometer (D) regulates the maximum speed of the machine from 0 to 100%.

The potentiometer setting chosen will depend on the particular work conditions; whatever the conditions, the operator must only work at a speed that ensures they retain full control of the machine at all times.

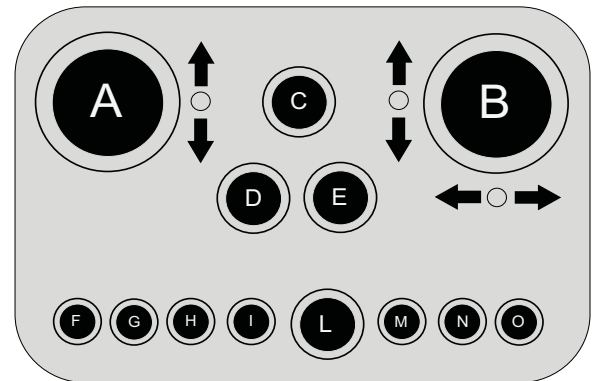

— 6.4.5 - STEERING —

The machine is steered by using the right hand side joystick (B). Move it to the right or left in to steer the machine.

When used in combination with joystick (A) it enables the machine to be turned by 180°. (counter-rotation).

ATTENTION:

Perform this manoeuvre only whilst on level ground.

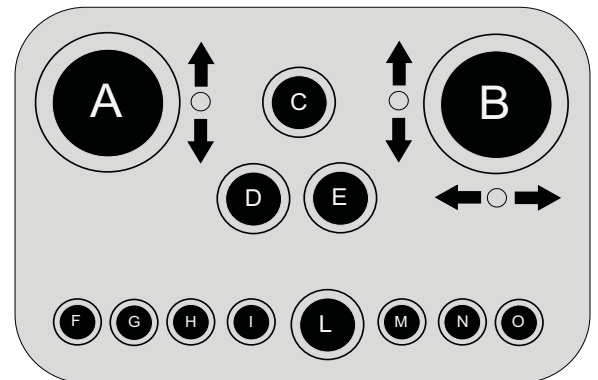

— 6.4.6 - STEERING BIAS CONTROL —

Potentiometer (E) enables the direction of travel to be compensated when working on steep slopes.

Turn the potentiometer to the right or left to correct the path of the machine.

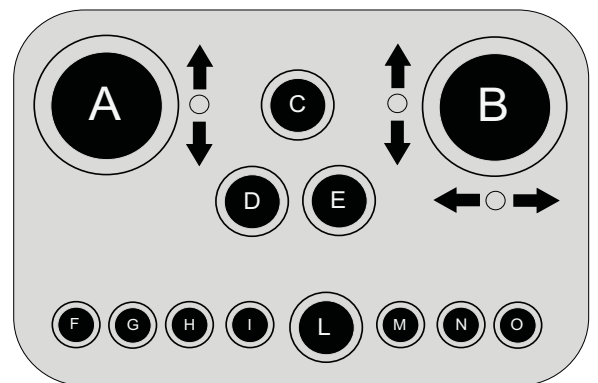
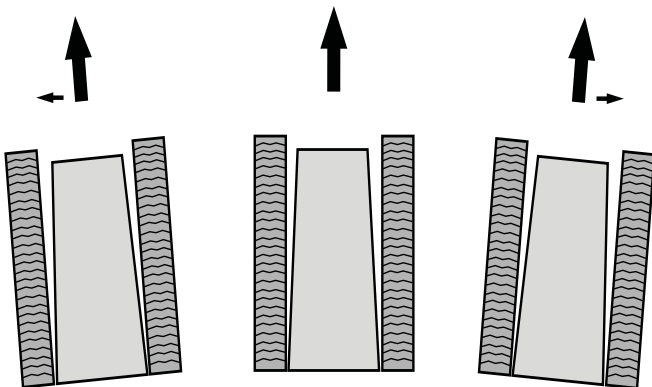

- McCONNEL ROBOMAX -

—6.4.7 - HEAD HEIGHT ADJUSTMENT (MOUNTED TOOL)

The height of the equipment mounted on the front of the machine can be adjusted using the right hand joystick (B); move the joystick forwards to lower the equipment, move it in the backwards direction to raise it.

ATTENTION:



Lower equipment to the ground and allow the ram rod to come out until it reaches the centre of the slot. In this mode the tool will accurately follow the ground contours (floating mode).

ATTENTION:



Use the lifting device only when the head's rotor is stationary.

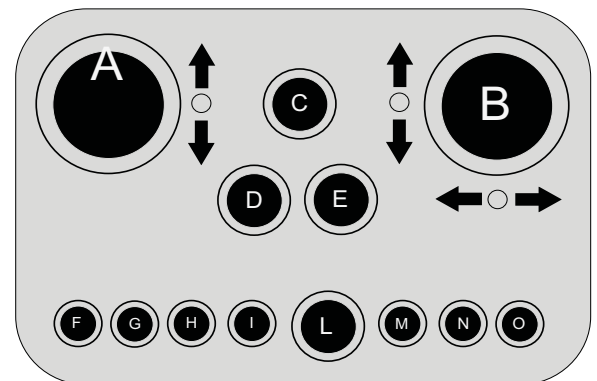

—6.4.8 - STARTING THE CUTTING FLAILS

The operation of the rotor is controlled via switches "I" and "L". Follow the instructions below to start it.

Select the cutting direction by using switch "I"; upwards selects clockwise rotation and downwards selects anti-clockwise rotation.

To start the rotor, turn potentiometer "L"; when the rotor begins to rotate, increase its rotation speed by turning the potentiometer up to 100%.

At this point, you can increase the speed of the diesel engine to the required working speed using button "R".

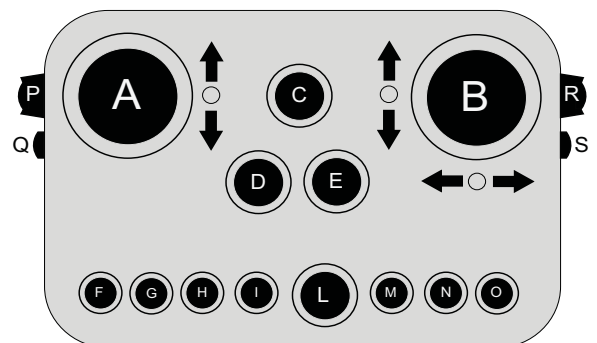

- McCONNEL ROBOMAX -

—6.4.9 STOPPING THE CUTTING FLAILS

To stop the rotor simply move potentiometer “L” to position “0”.

Reduce the speed of the diesel engine by using button “S”.

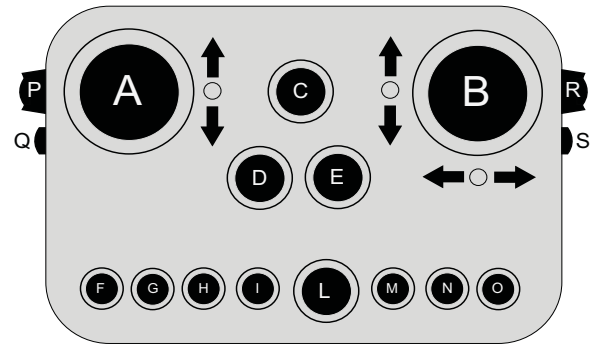

—6.4.10 - DIESEL ENGINE SPEED CONTROL

Buttons “R” and “S” on the right hand side of the remote control are used to increase and decrease the speed of the engine respectively.

Press repeatedly, or keep pressed, to make the required speed changes.

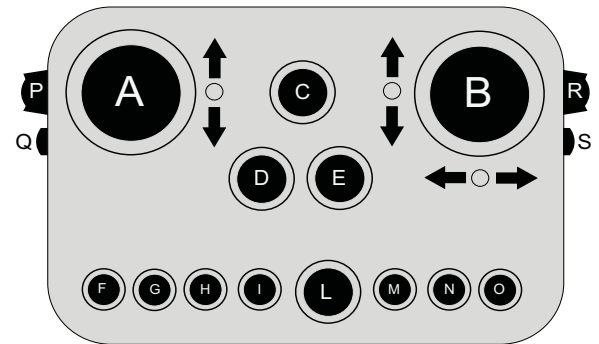

—6.4.11 - OPENING THE FRONT GUARD

Keeping switch “M” pressed upwards operates the hydraulic ram that opens the front guard. Move it downwards to close the front guard.

Pruning Version:

Keeping switch “M” pressed upwards operates the hydraulic ram that lifts the tool.

Move it downwards to lower the tool.

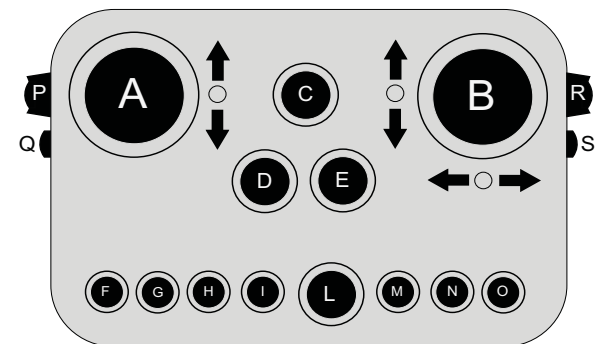

DANGER:



Guard opening function must only be used WHEN THE ROTOR IS STATIONARY as a means of accessing foreign bodies that are wrapped around the rotor. The operator must stop the rotor rotation and wait for the flails to come to a complete standstill before attempting to open the front guard of the head.

- McCONNEL ROBOMAX -

—6.4.12 - REVERSIBLE FAN CONTROL

Keeping switch “F” pressed upwards operates the fan blade reverse control.

This function will reverse fan blade rotation to clear the radiator of any build up of cuttings debris.

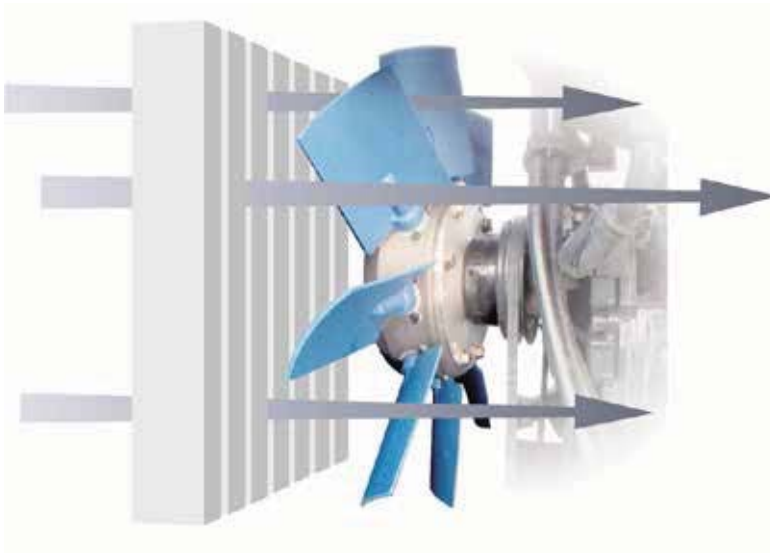
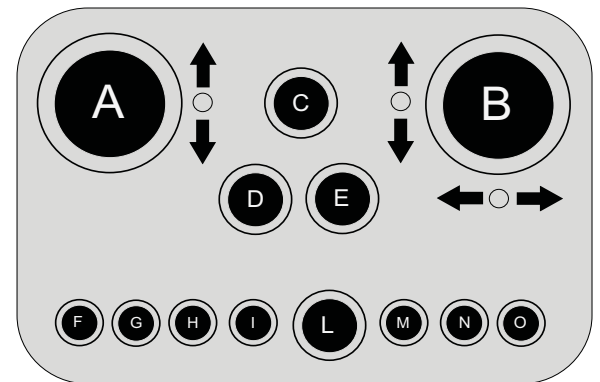

Reversible fan in normal working mode (Suction)

Reversible fan during radiator cleaning mode (Blowing)

ATTENTION: Before reversing the direction of the fan blades, reduce the speed of the diesel engine to idle speed, actuate the blade reverse control and then gradually increase the speed of the diesel engine.

ATTENTION: Before reversing the direction of the fan blades, make sure that there are no people or animals close to the machine or in the direction of the radiator to prevent them being covered with dust. Maintain a distance of at least 10m from the machine and wear the recommended PPE.

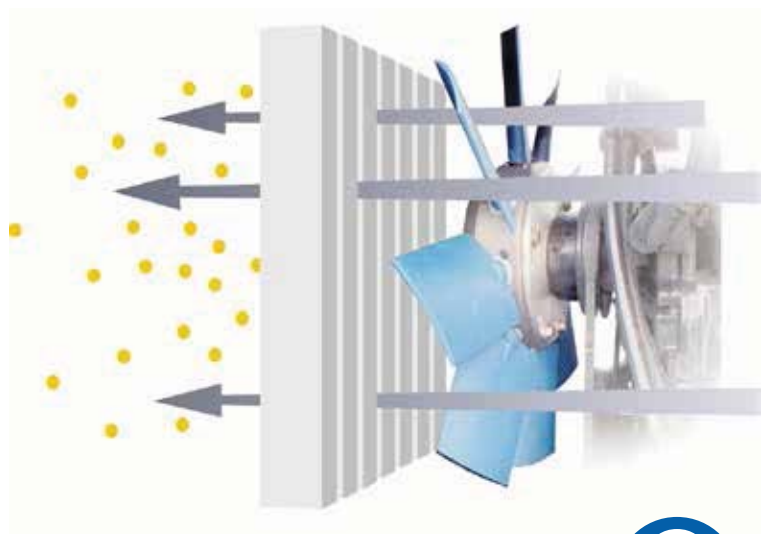

- McCONNEL ROBOMAX -

6.4.13 - OPTIONAL

Button "N" optional.

On the Pruning version;
Moving the selector upwards moves the ram outwards.
Moving the selector backwards moves the ram inwards.

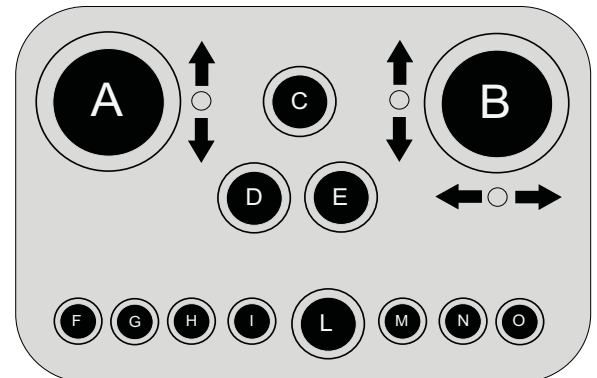

6.4.14 - OPTIONAL

Button "O" activates the ON-OFF function of the quick couplings located on the front left of the machine.
Pruning Version: Press button "O" to actuate the hydraulic motors of the tool. Press again to stop the motors.

ATTENTION: Once the button has been pressed, the speed of the diesel engine will be limited to 1700 rpm. Turn off the machine to reset the maximum rpm.

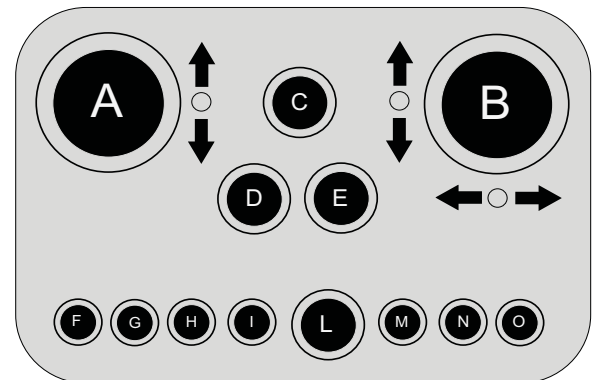

6.4.15 - TURNING OFF THE DIESEL ENGINE

To turn off the diesel engine, proceed as follows:

- Bring the machine to a halt.
- Stop the rotation of the rotor of the cutting head or the particular mounted equipment being used.
- Bring the engine to idle speed using button "S".
- Press button "Q" to turn off the engine.
- Turn the ignition key to position "O".
- Remove the key if the machine is to be left unattended.
- Turn off the remote control by pressing stop button 'C'.

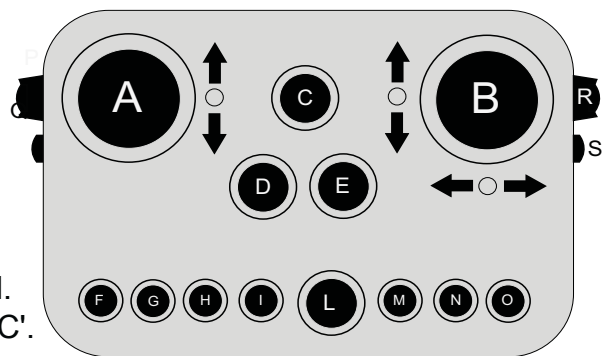

ATTENTION:



Always remember to turn off the ignition key after turning off the diesel engine; if the key remains in the "ON" position, the electric diesel pump can overheat and draw in air causing it to break.

McConnel reserve the right to replace damaged parts only after having examined them.

- McCONNEL ROBOMAX -

6.4.16 - S-KEY

In the transmitter unit, the address of the remote control is stored in the S-KEY. Therefore, without this key, the remote control cannot function.

The S-KEY must be used exclusively with the transmitter unit of the remote control to which it belongs (main transmitter unit).

ATTENTION:



Do not remove the S-key to turn off the machine and/or the remote control. Use the appropriate controls.

If the remote control has to be replaced, the old S-key must be inserted into the new remote control. The code must then be memorised following the procedure stated below:

- Press the stop button (C)
- Press the START button and keep it pressed until the green LED turns off
- Release the stop button (C)

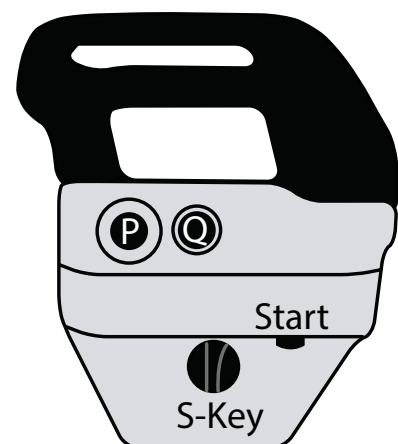
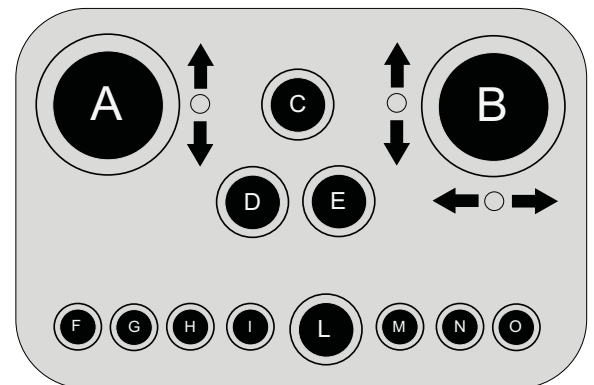
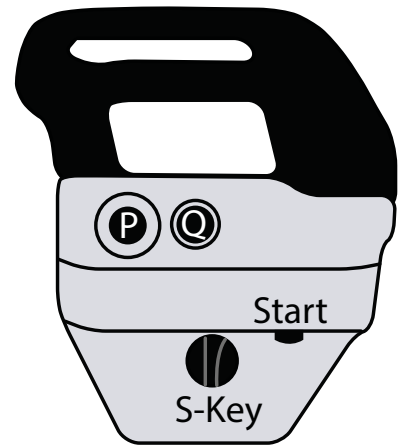

- McCONNEL ROBOMAX -

6.5 - LCD DISPLAY

- Description

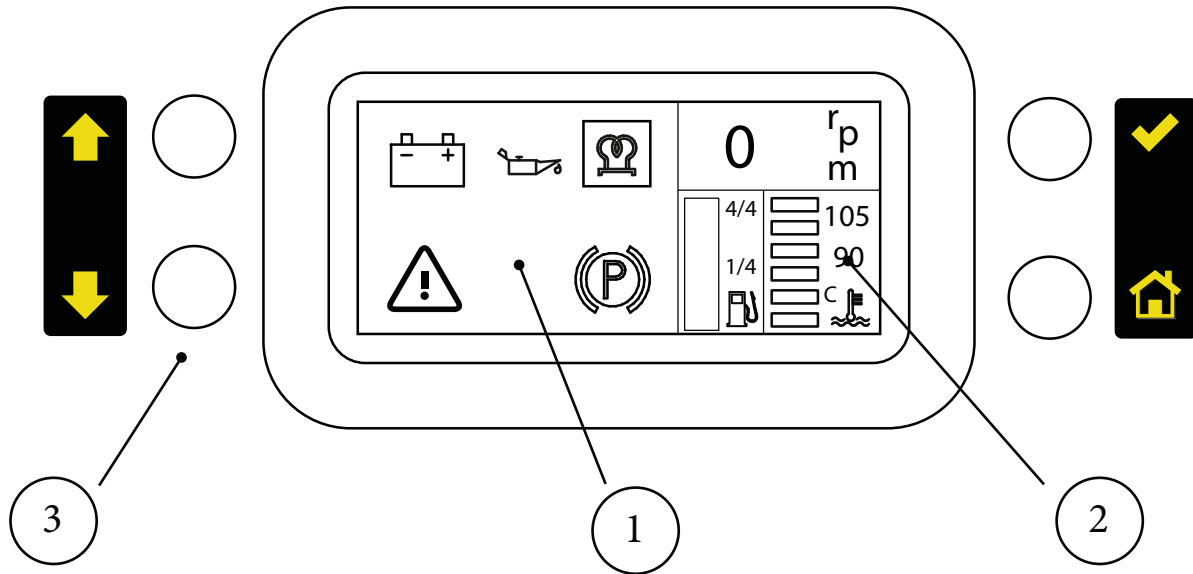

Area 1 - Indicator lights and error code

Area 2 - Coolant temperature

Area 3 - Buttons (Page Up/Page Down/Enter/Home)

- Home page

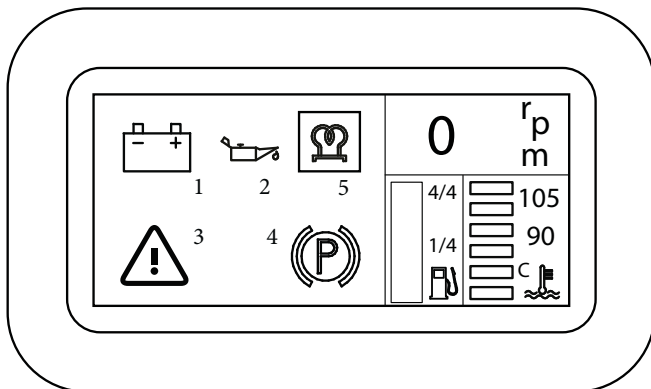

To turn on the display simply turn the start key (without starting the engine).

On the home page you can view:

- Battery/alternator indicator light (1)
- Low engine oil pressure indicator light (2)
- Parking brake indicator light (4)
- Engine stop indicator light (3)
- Glow plug preheating indicator light (5)
- Fuel level
- Coolant temperature
- Engine RPM

- McCONNEL ROBOMAX -

Maintenance Menu

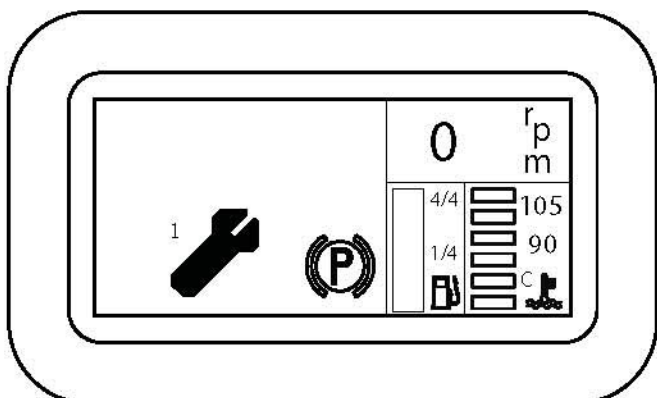

The display indicates the machine operating hours and the number of hours scheduled for carrying out maintenance.

See the Maintenance section when the scheduled number of hours have been reached.

Indicator light (1) appears when the time for maintenance has been reached.

Press the Page Up or Page Down key to view the hour counter and the type of servicing required.

ATTENTION: The Service indicator light will flash every time the engine is started until the release code is entered (once the machine has been serviced).

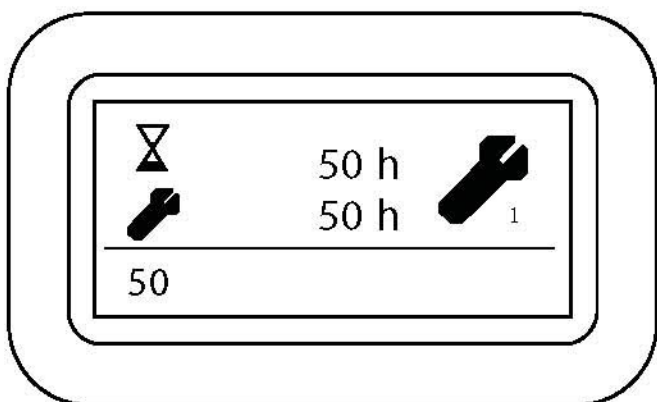

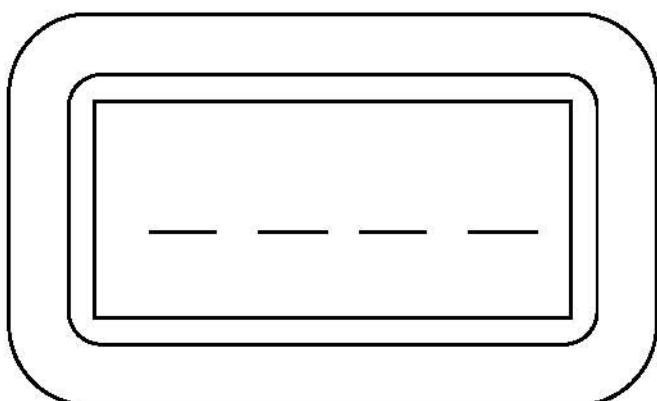

- Maintenance code



When the service has been completed, enter the numeric code (4 digits) supplied with the machine or contact the McConnel Service Department.

Keep the Enter button pressed for 3 seconds in order to display the page 

Enter the code by moving from left to right using the Home button. 

Confirm by pressing the Enter key. 

ATTENTION:









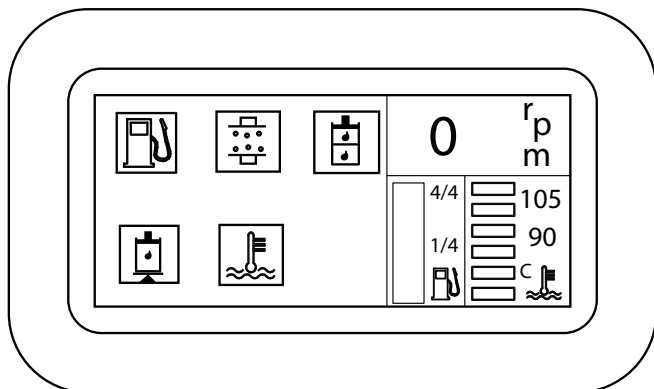

Entering the code without having carried out the required service will invalidate the McConnel warranty.

- McCONNEL ROBOMAX -

- Malfunctions

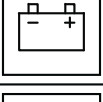
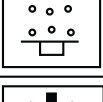
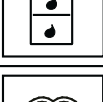

The following indicator lights/warnings may appear on the display according to the faults that may arise.

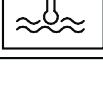
	HORN	ENGINE STOP	CAUSE	SOLUTION
	YES	NO	Fuel tank less than 1/4 full	Top up
	NO	NO	The parking brake is on	Move the left hand side joystick forwards/backwards
	YES	NO	Hydraulic oil level less than 2/3	Top up and/or check for leaks
	NO	YES	Oil level too low	Top up and/or check for leaks
	NO	NO	The alternator does not charge the battery	Check the alternator and/or contact customer care
	NO	YES	The air filter is clogged	Clean the filter elements
	NO	YES	The hydraulic oil filter is clogged	Replace the cartridge
	NO	NO	Glow plug preheating is active (optional)	Wait for the indicator light to turn off and start the machine
	NO	YES	Engine oil pressure too low	Check the engine oil level and/or the sensor
	NO	YES	Engine stop	Release the emergency button
	NO	YES	Coolant temperature > 110°C	Clean the radiator and/or check the level of coolant

- McCONNEL ROBOMAX -

- Alarms

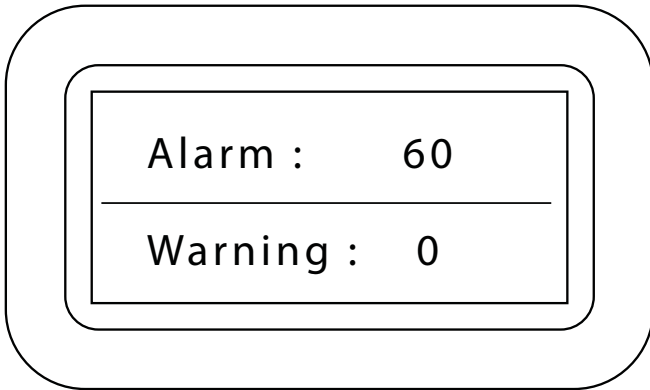

If the machine breaks down and/or malfunctions, "Alarm" codes will appear on the display followed by a number that identifies the type of error.

Error Code	Cause
Set 4 + number	Display fault/error
Set 6 + number	Remote control communication fault/error
Set 7 + number	Remote control manipulators fault/error
Set 9 + number	Inclinometer (optional) fault/error
Set 50 + number	Control unit outputs fault/error

ATTENTION:



Contact McConnel Service Department for further information and/or advice.

- McCONNEL ROBOMAX -

6.6 - FAULTS

The Troubleshooting Charts below serve to provide an indication to malfunctions or problems that could possibly occur when using this machine and provides measures that can be taken in order to eliminate them.

NOTE: - Should you experience any of the problems contact McConnel stating the malfunction or problem that occurred along with the machine identification number and the hours of operation.

(*) If the fault or cause is not listed below, contact the McConnel Service Department for advice.

6.6.1 - DIESEL ENGINE

Problem	Possible Cause	Solution
The low oil pressure indicator light remains on even when the engine is running at a high number of revolutions	<ul style="list-style-type: none"> - The level in the oil sump is low. - Clogged oil filter. - The oil is not suitable for the season. 	<ul style="list-style-type: none"> - Fill to level. - Change the filter. - Change the oil.
Steam comes out of the radiator's vent pipe. The engine water temperature indicator indicates overheating (red field).	<ul style="list-style-type: none"> - Low fluid level, fluid leakages. - Loose fan belt. - Radiator fins clogged. - Defective thermostat. - Radiator cap loose or broken. 	<ul style="list-style-type: none"> - Add the fluid, repair. - Check belt tensioning. - Clean the radiator. (*) Replace the cap or the unit.
The engine water temperature indicator is at the right-hand full scale.	<ul style="list-style-type: none"> - Defective tool. 	(*) Replace.
The engine water temperature indicator is at the left-hand full scale.	<ul style="list-style-type: none"> - Defective tool. - Defective thermostat. 	(*) Replace.
The engine does not start while the starter is running.	<ul style="list-style-type: none"> - Lack of fuel. - Air inside the supply system. - Defective compression. 	<ul style="list-style-type: none"> - Fuel up. - Check for possible breakages or leakages inside the supply and intake pipes. (*) Adjust valve clearance.
Exhaust gases are white or light blue.	<ul style="list-style-type: none"> Too much oil in the sump. - Inappropriate fuel. 	<ul style="list-style-type: none"> - Fill to level. - Replace with adequate fuel.
Exhaust gases tend to be black.	<ul style="list-style-type: none"> - Clogged air filter. - Defective injectors. - Defective compression. 	<ul style="list-style-type: none"> - Clean or replace. (*) Replace. (*) Adjust valve clearance.
Sometimes the noise produced by compression is similar to a breath	<ul style="list-style-type: none"> - Defective injectors. 	(*) Replace.
Odd noises (due to combustion or mechanical parts)	<ul style="list-style-type: none"> - Fuel with a low cetane number. - Overheating. - Damaged silencer. - Excessive valve clearance. 	<ul style="list-style-type: none"> - Replace with adequate fuel - Check for the presence of errors on the diagnostic tool. (*) Replace the silencer. (*) Adjust valve clearance.

- McCONNEL ROBOMAX -

6.6.2 - ELECTRIC CIRCUIT

Problem	Possible Cause	Solution
Lights are not properly lit even when the engine is running at a high number of revolutions.	- Defective cables.	(*) Check and repair the defective terminals and cables.
Lights are not steadily lit while the engine is running.	- Defective fan belt tensioning.	- Adjust belt tensioning.
The alternator's charger indicator light does not turn off when the engine is running and accelerated.	- Defective alternator. - Defective cables.	(*) Replace.
The starter does not run when the key is turned to the ignition position.	- Defective cables. - Insufficient accumulator charge. - Defective main fuse.	(*) Check and repair. - Charge the accumulator. - Replace.
The starter pinion is inserted and then released.	- Insufficient accumulator charge.	- Charge the accumulator.
The starter makes the engine run slowly.	- Insufficient accumulator charge. - Defective starter.	- Charge the accumulator. (*) Replace.
The starter deactivates before the engine starts.	- Defective cables. - Insufficient accumulator charge.	(*) Check and repair. - Charge the accumulator.
The charge indicator light of the alternator does not turn on when the engine is stopped (ignition key on "I").	- Defective lamp. - Defective cables.	(*) Replace. (*) Check and repair.

6.6.3 - HYDRAULIC SYSTEM

Problem	Possible Cause	Solution
The pump emits a strange noise.	- Defective pump - Lack of oil in the tank.	(*) Repair or replace. - Fill to level.
The equipment works at low speed.	- Defective pump. - Maximum pressure valve out of calibration or not closed due to impurities. - Clogged discharge filter.	(*) Repair or replace. (*) Calibrate or replace. - Replace the cartridge.

- McCONNEL ROBOMAX -

6.7 - FUSES AND RELAYS

ATTENTION:



Before replacing a fuse, make sure that you have removed the ignition key. If the fuses are oxidised, corroded or not properly held in position, replace them with fuses that have the same rating. If the engine does not turn on when the starter switch is set to the on position, check the main fuse and replace it, if necessary.

6.7.1 - CONTROL UNIT FUSES AND RELAYS

The control unit fuses and relays are located in the control panel fuse box (a). Remove the protective panel and if necessary replace the fuses or relays.

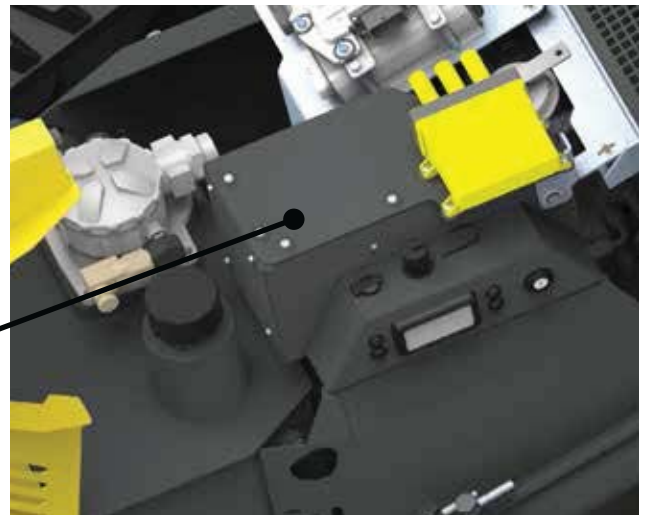

a

Fuse and relay layout

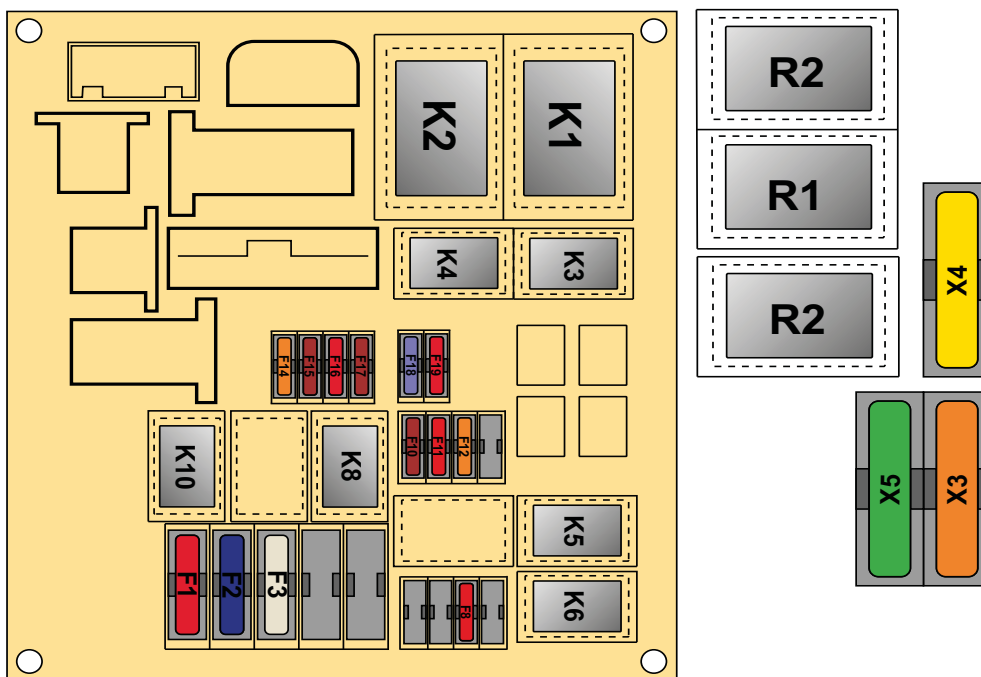

- McCONNEL ROBOMAX -

No.	Function	Amp.
F1	Controls Positive	10 A
F2	+15 Engine	15 A
F3	Work lights	20 A
F4	Empty	
F5	Empty	
F6	Empty	
F7	Empty	
F8	Horn	10 A
F9	Empty	
F10	Diesel pump	7.5 A

No.	Function	Amp.
F11	Power outlet	10 A
F12	+12 Control panel	5 A
F13	Empty	
F14	Alternator	5 A
F15	+12 Sensors	7.5 A
F16	VE Le70	10 A
F17	Actuator	7.5 A
F18	+ 30 Display	3 A
F19	General Engine	10 A
F20	Empty	

MAXI FUSES		
X3	Main fuse	40 A
X4	VP (power inputs)	20 A
X5	Starter fuse	30 A

- McCONNEL ROBOMAX -

6.8 - HOW TO ATTACH EQUIPMENT

The machine is fitted with a moveable front hitch to which the various approved tools/equipment can be attached. To do this, follow the steps below:

- Start the diesel engine and connect using the remote control (see chapter 6.4.1).
- Lower the front lifting device as far as possible using the right hand side joystick (B).
- Slowly move the machine forwards until it engages with the equipment.
- Slowly lift the front lifting device until the equipment is properly attached.
- Secure the tool to the machine support using 4 bolts.
- Turn off the engine.
- Connect the hydraulic power hoses (a) to the quick connect couplings on the machine (right hand side), make sure to carefully clean the couplings before connecting them.
- Connect the hydraulic services hoses (b) to the quick connect couplings (left hand side).
- Also carefully check the information regarding attaching tools and equipment in the specific manuals of the individual pieces of authorised interchangeable equipment.

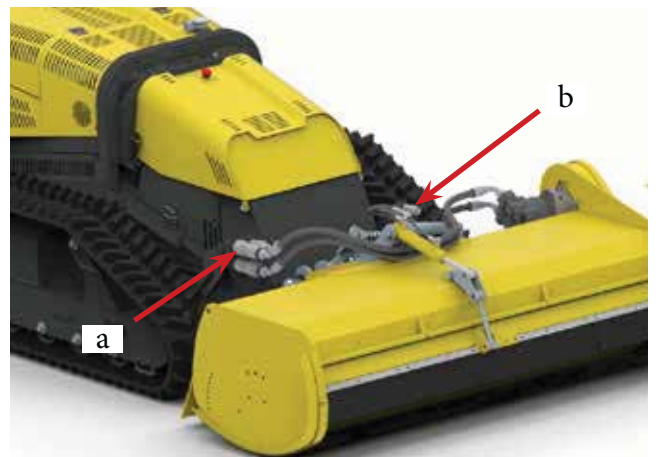

ATTENTION:



Firmly tighten the hydraulic couplings after attaching the tool.

Max. tightening torque: 50 Nm.

Failure to tighten (even partially) can cause the breakage of the equipments hydraulic motor.

- McCONNEL ROBOMAX -

6.9 - WORKING WITH THE MACHINE

DANGER:



Before moving the machine, make sure that you are familiar with all the controls and all Safety Standards. The operator must be in the vicinity of the machine. Before moving the machine, ensure that no persons are within the range of the machine and that the area of action is free of obstacles. Use great caution before starting reverse motion and always check for the presence of persons, equipment or obstacles.

- Before starting to cut, check that there are no foreign bodies such as stones, pieces of metal or any animals in the vicinity.
- Only cut grass and light brushwood that the machine is capable of processing without difficulty.
- When mowing slopes always start from the bottom.
- Always turn round in an upwards direction.
- Never go down slopes that have an inclination greater than 50°
- Never stand directly in the line of fall of the machine.

Never change the direction of the machine while moving on curbs, rocks or surfaces with large differences in height (greater than 20 cm). In these cases, always proceed perpendicular with respect to any obstacles.

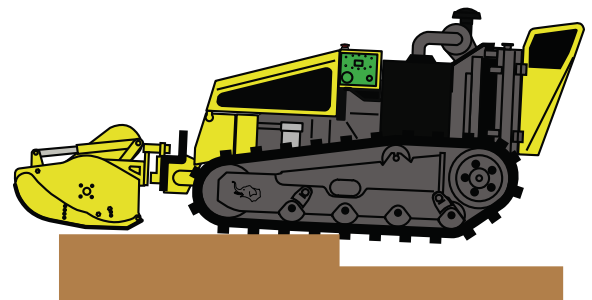

When reversing uphill, do not change direction in the transition area between the flat ground and the slope. If it is unavoidable to do so; carry out the manoeuvre gradually.



Avoid moving along the edge of a slope or on uneven ground with one track in a horizontal position and the other inclined or partially raised (with the machine inclined more than approximately 10°). In order not to damage the tracks, always proceed with the both tracks on the same horizontal plane.

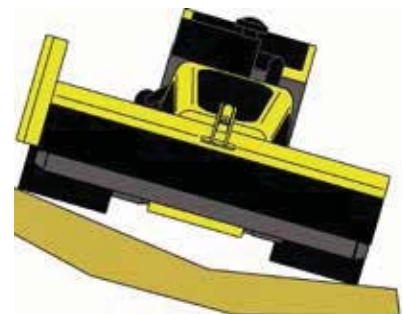

- McCONNEL ROBOMAX -

When the machine manoeuvres over an obstacle it creates an empty space between the bearing rollers and the tracks and there is a risk that the track may come out of its seat.

The same may happen if the machine is reversing uphill and you try to make a sharp turn. An empty space is created between the bearing roller, the front idler roller and the track, and there is a risk that it may come out of its seat.

When changing direction and the track cannot move sideways due to an obstacle, the track could become damaged and come out of its seat.

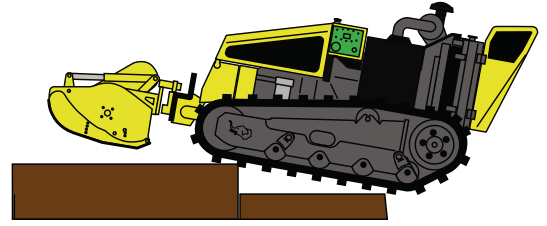

DANGER:



SLIPPING OR OVERTURNING

In order to avoid serious risks or the death of the operator it is prohibited to work on slopes that have hard surfaces (e.g. cement). When working in conditions in which the machine is operating on an inclined plane that has a slope greater than 25° , always stand upstream of the machine or sufficiently far away from it (minimum 20m).

ATTENTION:



If the machine tips over it is recommended to quickly turn off the engine and not to restart it, otherwise the engine could become seriously damaged. Put the machine back into its original position as soon as possible. Before turning on the engine, contact an authorised service centre to check the condition of the engine.

6.10 - CONTROL STATION - OPERATOR WORK AREA

The operator must always be at a minimum distance of at least 5m from the machine. It is advisable for the operator to wear PPE.

The operator must try to position himself in the recommended work areas with respect to the machine. This is a zone where they have optimum vision of the machine and work area but not in the area where possible objects may be thrown out of the machine; apart from when operating on slopes of greater than 25° for which the previous instructions should be followed.

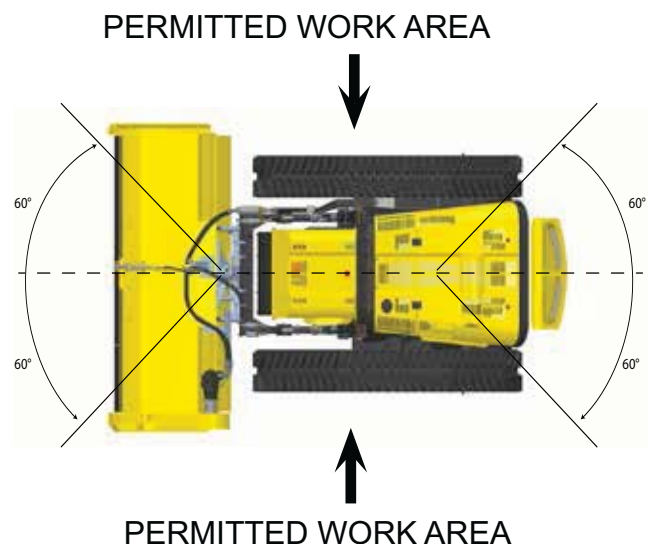

- McCONNEL ROBOMAX -

7 - TRANSPORT AND HANDLING

7.1 - LOADING AND UNLOADING FOR ROAD TRANSPORT

Use suitable vehicles with a carrying capacity of greater than 2500 kg to transport the machine to/ from the work area.

Use loading ramps, both of which are suitable for supporting a load of not less than 2000kg and which are hooked to the bed of the vehicle. The ramps must be placed at the correct width for the tracks and at an angle of no more than 50°.

Once the machine has been loaded onto the vehicle, it is recommended to secure it to the vehicle using wire ropes or slings attached to the lifting rings (a).

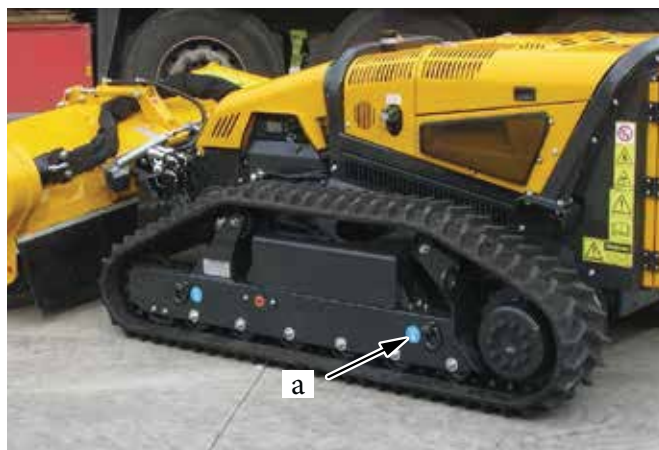

If the machine has to be lifted in order to load it, make sure to use suitable chains or wire ropes for lifting it.

Hook the wire ropes or chains to the lifting rings provided (a).

It should be noted that when using wire ropes, slings or chains to lift the machine, you must comply with all handling rules and regulation relating to their safe lifting angles.

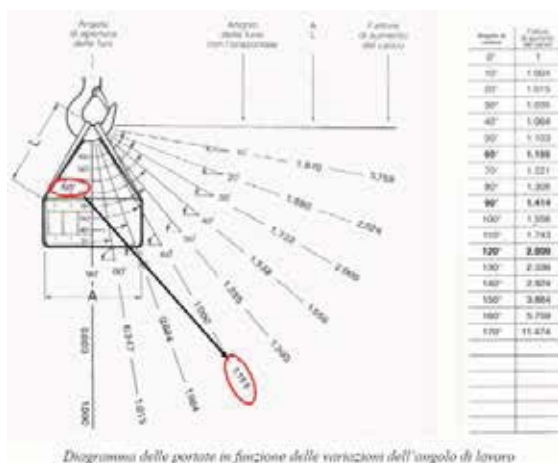

- McCONNEL ROBOMAX -

7.2 - TOWING THE MACHINE

DANGER:



When the machine is towed; use a steel cable with a strength suitable for the weight of the machine being towed.

If the machine needs to be towed because the diesel engine or other essential components have broken down, the parking brake must be released manually.

To release it proceed as follows:

- 1 - Remove the cover (a).
- 2 - Remove the rubber plug on the drive motor (b).
- 3 - Using a 20x50x250 mm plate having a centre hole ($\varnothing 13$ mm.), screw an M12x70 bolt into the threaded hole of the drive as far as it will go. Using a M12 nut (previously threaded onto the bolt), tighten it slowly until the brake is released.
- 4 - Repeat the same procedure for the other drive motor using another kit (plate + bolt).

At this point, both drive brakes have been released and the machine can be towed.

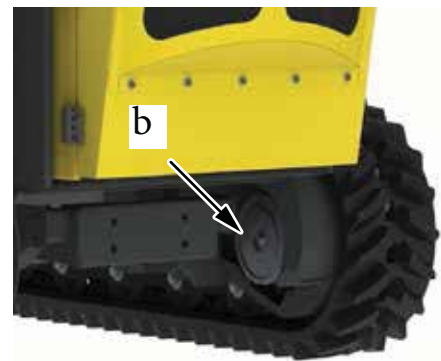
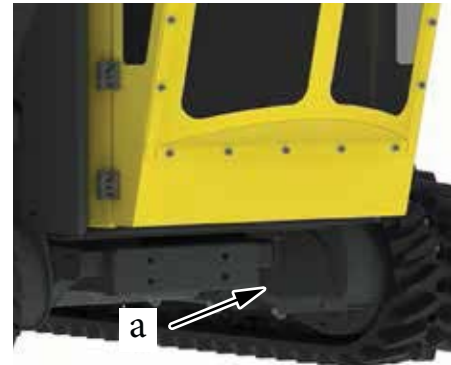

WARNING:

Tow the machines with a continual, consistant force, without revving. Make sure that no components on machine are at risk of fouling with the towing cable and try to ensure that the machine is towed as much as possible in a straight line. Never attempt to tow the machine using with a worn out, broken, twisted or deformed cable. Only tow the machine for short distances to enable it to then be loaded onto a transport vehicle.

- McCONNEL ROBOMAX -

7.3 - USING THE MANUAL CONTROL

In the event that it is necessary to move the machine without using the remote control (e.g. batteries are in a discharged state), it can be done by connecting the manual control unit supplied with the machine.

In order to do this follow the instructions below:

- 1 - Lift the front bonnet (a).
- 2 - Insert the connector and tighten locking ring (b).

The engine can now be started using the ignition key.

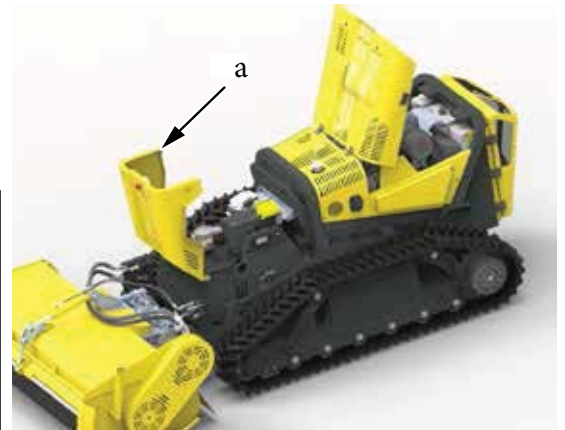
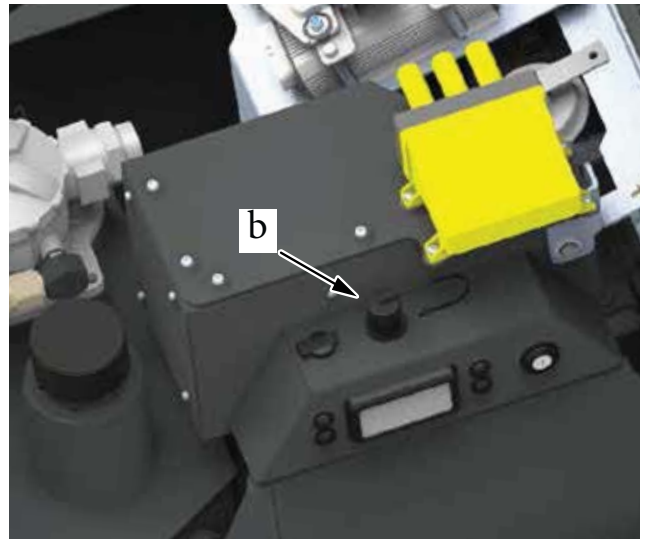

ATTENTION:



Only use the manual control in the event of emergencies. With the manual control connected, all operating functions are disabled apart from forward movement and lifting the attached equipment.

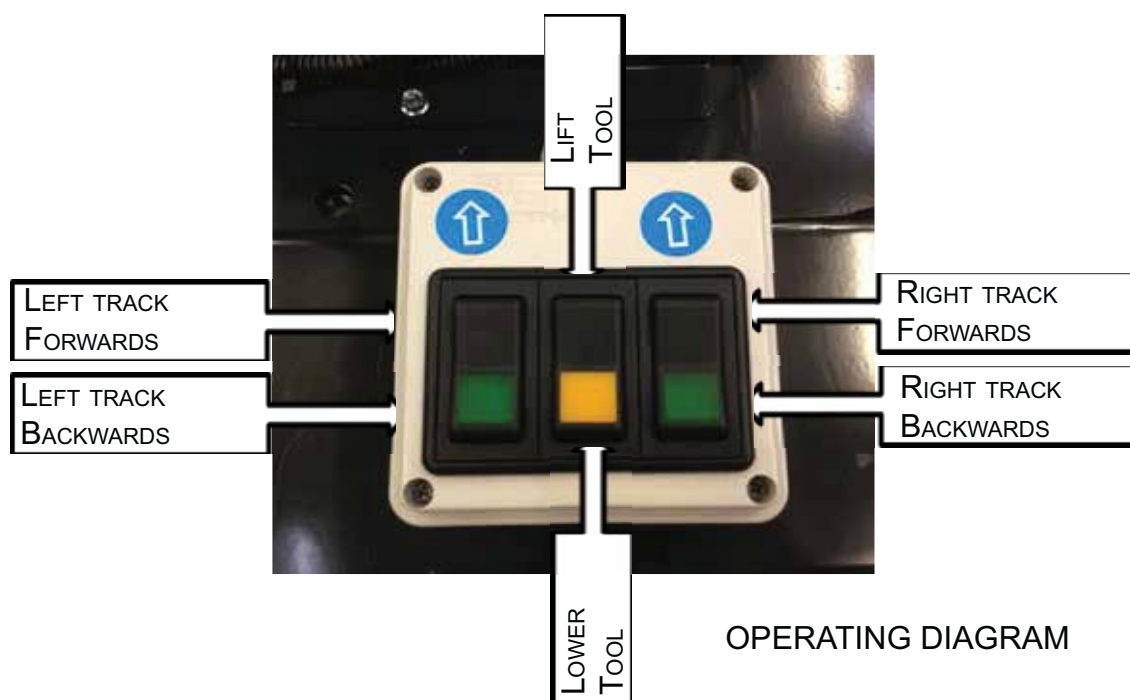

OPERATING DIAGRAM

- McCONNEL ROBOMAX -

7.4 - STARTING THE ENGINE USING JUMP LEADS AND AUXILIARY BATTERY

If the engine has to be started using an external battery, proceed as follows:

- 1 - Remove the cover from the battery compartment (a) located on the right hand side.
- 2 - Connect one red terminal of the lead to the positive terminal (+) of the battery and the other to the positive terminal (+) of the auxiliary battery.
- 3 - Connect one black terminal of the lead to the negative terminal (-) of the battery and the other to the negative terminal (-) of the auxiliary battery.

The engine can now be started using the ignition key.

Bring the speed of the diesel engine to 1000 rpm and wait for a few minutes before disconnecting the external battery.



ATTENTION:



Do not use battery chargers or start boosters to start the engine. They may damage the electronic control units.

DANGER:



Do not check the charge of the battery by connecting the two poles with a metal object. Use a voltmeter.

The battery earth connector (-) must always be disconnected first and always re-connected last.

The sulphuric acid in the battery electrolyte is poisonous. It can burn the skin, pass through fabrics and cause blindness if it comes into contact with the eyes.

Please note that lead and its compounds cause cancer and other damage to reproductive organs. These substances are present in the battery poles, terminals and accessories. Wash your hands after touching them.

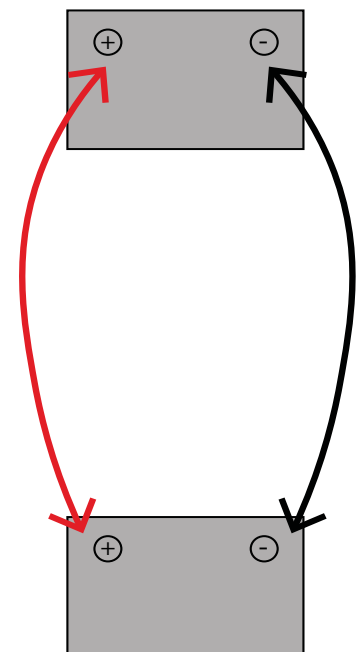

- McCONNEL ROBOMAX -

8 - STORAGE

If the machine is not used for long periods, it must be stored in a location where it is protected from the elements to prevent damage. Before storing the machine, it is recommended that you clean it thoroughly and lubricate all mechanical components to protect them from rust.

The machine should be stored at a temperature between 0°C and 40°C.

Before storing the machine for long periods, you are recommended to perform the following steps:

- Clean the equipment (e.g. rotor and tools) to remove any cutting residue.
- Clean the machine thoroughly.
- Perform a visual inspection on the whole machine to identify any structural damage or deep scratches on the paintwork, and ensure that the original safety signs are in good condition, are still fully legible and are located in their original positions.
- Grease all mechanical parts subjected to friction, lock pins and all machine parts no longer coated with their original paint layer in order to prevent rust from forming.
- Store the machine in a covered area and on a flat and firm surface.
- Fill the fuel tank completely
- Disconnect the cables from the battery
- Make sure that the ignition key is removed and the remote control kept in a separate secure location.

ATTENTION:



If the machine or any of its parts are to be decommissioned, all parts that could constitute a hazard must be made safe.

DANGER:



The fluids contained in the machine, once drained from the circuits and tanks must be collected into appropriate receptacles, taking care to ensure they do not come into contact with any areas of the skin, eyes or mouth.

- McCONNEL ROBOMAX -

8.1 - DISMANTLING AND DECOMMISSIONING

If you no longer wish to use the machine, or parts of it, you must dismantle and decommission the machine.

Before scrapping; plastic/rubber parts and electrical and electronic materials must be separated. Drain any used fluids and dispose of them in a recycling facility equipped to handle these products.

Carry out all these operations in accordance with the regulations in force.

ATTENTION:



If the machine or its parts are decommissioned; all parts that could constitute a hazard must be made safe.

DANGER:



The fluids contained in the machine, once drained from the circuits and tanks must be collected into appropriate receptacles; take care to ensure they do not come into contact with any areas of skin, eyes or mouth.

- McCONNEL ROBOMAX -

9 - MAINTENANCE

ATTENTION:



Maintenance operations must be performed by McConnell Service or by qualified personnel at a recognised McConnell Dealership.
Always wear personal protective equipment before performing any work on the machine.



9.1 - INTRODUCTION

To obtain the machine's best performances and ensure maximum durability of all its components, the instructions for use and maintenance must be followed carefully by machine operators. Therefore, we recommend our customers to carefully read these instructions and consult the manual any time they need advice on how to eliminate possible inconveniences. Because the machine operates normally in contact with water, sand, earth, etc., regular lubrication is necessary, which assumes vital importance not only to ensure a long use of the machine, but also to reduce its running costs.

For further information, please contact our service centre:

McConnel Service Department; Tel: +44 (0)1584 875848

9.2 - GENERAL REQUIREMENTS

- *Before performing any maintenance work, inspection and/or check on the machine, turn off the diesel engine and remove the ignition key.*
- *During disassembly and re-assembly of machine parts, always use suitable extractors, wrenches and tools in order not to damage components.*
- *To unlock parts that are solidly adherent, use copper or wooden hammers.*
- *Sort out the pieces of the various units and partially refit nuts on their corresponding pins or stud bolts. Clean the parts using brushes or rags, then wash using petroleum or warm water. Remove all residues using compressed air.*
- *After sandblasting or finishing operations with abrasives, thoroughly clean the parts making sure that all abrasive powder residues have been removed completely.*
- *When re-assembling the pieces, make sure that they are clean. Then, lubricate appropriately.*
- *Pay great attention to the safety rings and lock pins. Replace them immediately if you notice any excessive wear or breaks.*
- *The maintenance operations of the machine and/or equipment must be carried out by authorised personnel.*
- *Should maintenance operations require the temporary removal of the guards that protect moving parts or hot surfaces, they must be re-fitted at the end of the operations.*

- McCONNEL ROBOMAX -

9.3 - EXTRAORDINARY MAINTENANCE

These are repairs or replacements of one or more components of the machine, which usually tend to become necessary after a few years of operation and which do not alter the characteristics of the machine. In the case of considerable changes, the manufacturer cannot be held liable for possible hazards which might arise.

These tasks must be performed by authorised personnel.

9.4 - LUBRICANT AND FLUIDS TABLES

<i>COMPONENT</i>	<i>RECOMMENDED LUBRICANT</i>	<i>INTERNATIONAL STANDARDS</i>
HYDRAULIC SYSTEM	<i>BIODEGRADABLE</i> PANOLIN HLP SYNTH E 46	FZG Test A/8.3/90 stage 12 (35635, 35640, 35645) ISO 15'380 HEES
HYDRAULIC SYSTEM	<i>MINERAL</i> Q8 ELI 1298 L	ISO 11158 Type HV Din 51524, Part 3 class HVLP
ENGINE	MOBIL SUPER 3000 X1 5W-40	API SM/SL/SJ ACEA A3/B3, A3/B4
PINS BUSHINGS BEARINGS	GREENPLEX EP GREASE	EP adhesive grease, Aluminium complex soap
COOLANT	PERMANENT SUPER ANTIFREEZE LF (Diluted 50%)	ASTM D3306 CUNA NC 956-16

ATTENTION:



When using Panolin HLP Synth E biodegradable oil, avoid mixing it with other oils. If the machine was delivered with mineral oil contact McConnel for information regarding the procedure for replacing it with biodegradable oil.

The use of non recommended lubricants and/or grease results in the forfeiture of the warranty.

ATTENTION:



We remind you that, each time you change the oil, replace batteries, rubber pipes, tyres and any parts of the machine to be disposed of for recycling, you are required to refer to, and abide by, all local regulations that are in force.

- McCONNEL ROBOMAX -

9.4.1 - FUEL

- We recommend the use of fuels compliant with Standards EN 590:96 or ASTM D975. Other fuels with different specifications can damage the engine or reduce its power.
For further details and/or information, consult the engine manual.
- When refuelling, check for water or moisture on the fuel tank cap, wipe off any wetness before you open the cap to avoid the risk of water entering the tank.
- Having run out of fuel or after changing the fuel filter, bleed the air from the fuel pipes.

DANGER:



When handling fuel or coolant, do not smoke or work near heat sources or sparks. Store flammable fluids away from areas with risk of fire. Do not incinerate or burn containers, and ensure the machine is kept clean to reduce the fire risks that can exist where grease or flammable residues are on or close to sources of heat.

9.5 ENGINE MAINTENANCE

9.5.1 - ENGINE OIL

The engine oil must be selected with the utmost attention (when selecting an engine oil refer to the tables in section 9.4); major maintenance works involving the engine oil are:

- Daily oil level check.
- Periodic oil change.



9.5.2 - COOLANT

Check the level of coolant in the reservoir (a) each day before starting the engine. The level must be between the two marks. Top up if necessary.

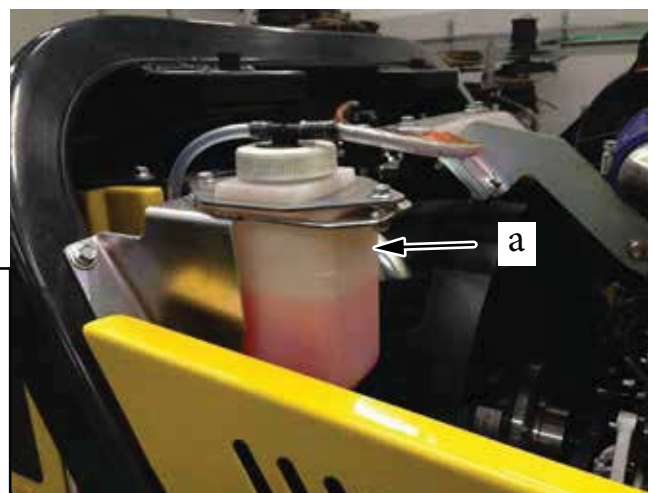

ATTENTION:



If the level is too low it can cause irreparable damage to the engine. Pressurised tank. Do not open the cap when the engine is hot.

- McCONNEL ROBOMAX -

9.5.3 - TOPPING UP

Open the lock using the appropriate key and unscrew the cap. Top up with fuel that complies with EN 590 or ASTM D975.

DANGER:



When handling fuel or coolant, do not smoke or work near heat sources or sparks. Store flammable fluids away from areas with risk of fire.

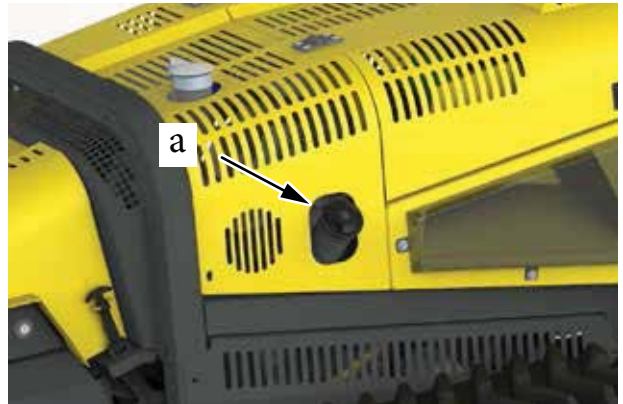

9.6 - MAINTENANCE OF THE HYDRAULIC SYSTEM

DANGER:



Use extreme caution when performing maintenance on the system; the oil gets very hot when the machine has been working. The pressure in the circuit is high, not only during the use of the machine but also when idle. Use a piece of cardboard to locate leaks. Protect your hands and body from high pressure fluids.

Maintenance interventions of the hydraulic system are:

- Daily check of the oil level in the tank.
- Periodic replacement of the oil filter (after 250 hours, or if the indicator signals that the filter is clogged).
- Periodic oil change (every 500 hours).

Always check the condition of the O-ring whenever a component of the hydraulic circuit is removed or replaced; if broken or damaged, they must always be replaced.

After re-assembly, bleed out any air that is present in the circuit as per the instructions below:

- Start the engine and keep it at low revs;
- Operate the hydraulic components to perform all their movements 4-5 times without reaching the end of their stroke.
- Then carry out all the movements 4-5 times, bringing the components to the end of their stroke.



- McCONNEL ROBOMAX -

9.7 - MAINTENANCE OF THE ELECTRICAL SYSTEM

Maintenance interventions of the electrical system are:

- Check the tensioning of the timing belt (a).
- Check the battery charge (b).

Do not remove or install any components without prior authorisation from McConnel.

Avoid any form of water contact with the electrical system.

Protect connection pins with anti-corrosives.

Do not carry out any modifications to the electrical system without prior authorisation from McConnel.

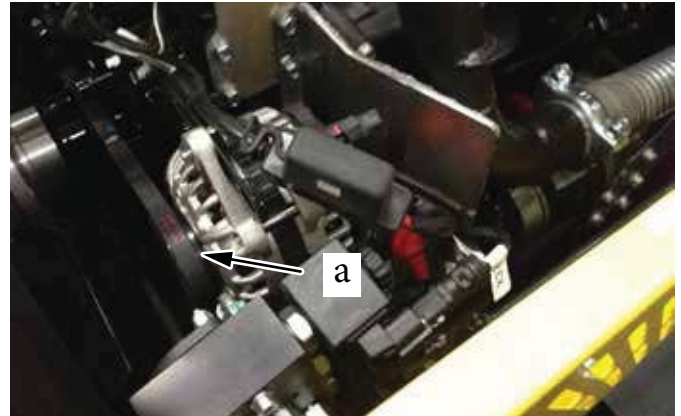

DANGER:



Do not check the charge of the battery by connecting the two poles with a metal object. Use a voltmeter. The battery earth connector (-) must always be the first to be disconnected and the last to be re-connected.

The sulphuric acid contained in the battery electrolyte is toxic and corrosive. It can burn the skin, pass through fabrics and cause blindness if it comes into contact with the eyes.

Please note; lead and its compounds cause cancer and other damage to reproductive organs. These substances are present in battery poles, terminals and accessories. Always wash your hands after touching them.

- McCONNEL ROBOMAX -

9.8 - PERIODICAL REPLACEMENT OF THE SAFETY COMPONENTS

To guarantee safety, the components listed below must be replaced at the frequency stated;

Component and replacement frequency:

- Fuel hoses..... Every 2 years or 4000 hours
- Hydraulic pipes..... Every 4 years or 4000 hours

9.9 - MAINTENANCE AS REQUIRED

9.9.1 - CHECK, CLEANING OR REPLACEMENT OF AIR FILTERS

DANGER:



The air filter must only be removed with the engine switched off. Never attempt to start or run the engine with the air filter removed or with the filter housing open. Wear protective clothing when carrying out any cleaning of the filter components.

WARNING:

The air filter assembly consists of a primary large capacity cartridge and a secondary cartridge. The primary cartridge can be cleaned with an air line, the secondary cartridge must always be replaced. Replace the primary cartridge after 6 cleaning operations or every year, whichever occurs first. When replacing the primary cartridge, the secondary cartridge must be replaced at the same time.

To access or replace the cartridges of the air filter unit:

- open the two fixing clamps (a) and remove the end cover from the air filter unit.



- McCONNEL ROBOMAX -

Remove the primary cartridge (b). If it is found to be difficult to remove, moving it to the left and right slightly as you pull the cartridge can aid its removal.

Clean the cartridge using a jet of air blowing from the inside outwards; this task must be performed outdoors or in a well ventilated location.

To remove the secondary cartridge for replacement;

- Pull the cartridge out of the housing.

When installing a new primary cartridge a new secondary cartridge must also be installed.



ATTENTION:



Do not wash the air filter elements. Do not use solvents. Use air lines with care - excessive compressed air could damage a cartridge. Do not oil the cartridges.

—9.9.2 - INSPECTION AND EXTERNAL CLEANING OF THE RADIATOR—

During mowing operations it is normal for cuttings to get sucked up by the engine fan resulting in the obstruction of the protective grilles; the reversible fan control “F” (see chapter. 6.4.11) should be used to clear the grilles as and when necessary.



WARNING:

If the diesel engine exceeds the maximum permissible temperature and indicator light No. 10 lights up on the ignition panel, the engine stops immediately (see engine manual).

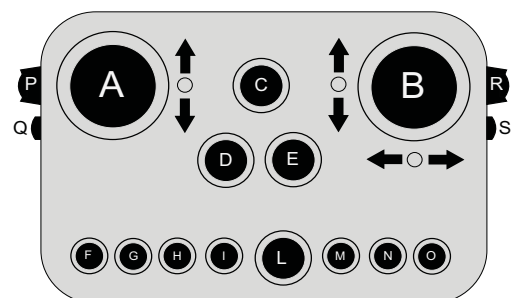

- McCONNEL ROBOMAX -

—9.9.3 - REPLACING THE TRACK

Tracks should be replaced when only 10mm of tread is remaining, or before if they show signs of excessive damage or cuts.

The procedure to replace tracks is as follows:

Place the machine on a firm level site with the engine turned off and raise it (30-40 cm) off the ground using 4 axle stands that are suitable for supporting the weight of the machine; position the stands on the side members of the chassis.

Thoroughly clean the parts of the undercarriage.

Remove cover (a) from the side of the chassis. Slowly loosen the tensioning valve (b) (Wrench 27mm) to release the grease from the valve. Remove the tensioning valve only when it is no longer pressurised and the track is completely loose.

Push back the front wheel by pressing the track with your foot.

Lift the lower half of the track to move the track away from its seat (outwards) by levering it off the idle wheel.

Installation of the new track is a reversal of the removal procedure.

The correct track tension is obtained by using the tensioning kit and injecting grease until a maximum pressure of 130 bar is reached. (refer to point 9.11.1)

DANGER:



The machine supports must be fully capable of supporting the load in a safe and stable position at all times.

For machine lifting see paragraph 7.1.

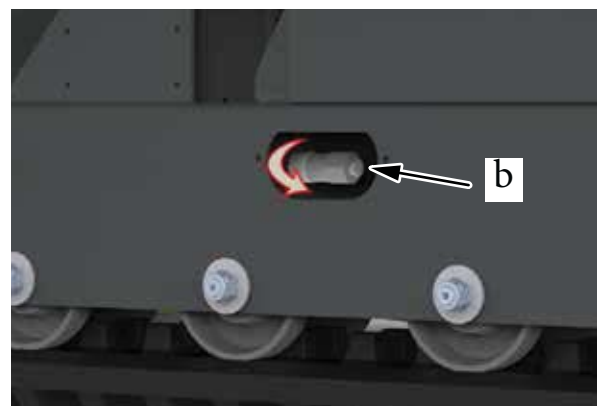

- McCONNEL ROBOMAX -

9.10 - CHECKS TO PERFORM AT THE START OF EVERY WORK DAY

Before each working day it is necessary to carry out an accurate visual check of the following parts and where necessary repair faults.

- Check that all screws, nuts and fixings are tight.
- Check for oil, fuel, coolant leaks.
- Check the work equipment and the relative guards for wear.
- Check the cleanliness of the machine and grease lubrication points.
- Check the track tensioning pressure.
- Inspect and clean the radiator.
- Check the operation of the audible warning devices and safety elements such as warning signs, emergency buttons and warning indicator lights.
- Checks of the protection/safety devices on the attached equipment (see equipment manual).

9.10.1 - COOLANT LEVEL CHECK

To check the coolant level, loosen the cap of the radiator (a) bleeding out the pressure slowly and check visually the level of the coolant.

The level of the coolant must be 2 to 3 centimetres above the elements of the radiator; if the level is low, top up the coolant until the correct level is restored. Close the cap.

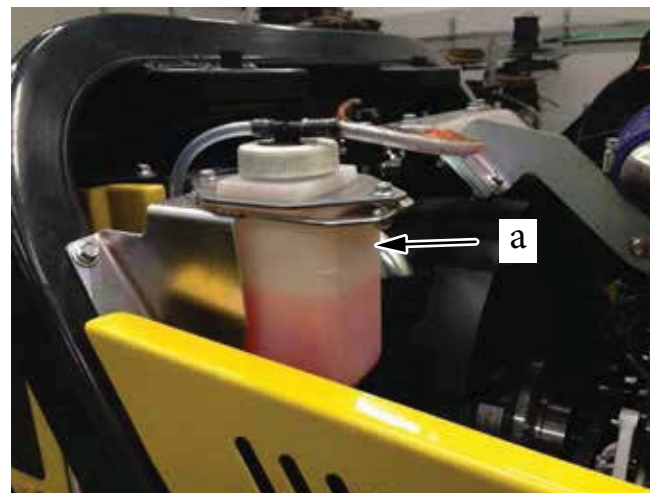

DANGER:



Explosive release of fluids from pressurised cooling system can cause serious burns. Stop the engine. Only remove the filler cap when the engine is cold or when it is cool enough to touch with bare hands.

Before removing the cap, loosen the cap slowly to the first stop to relieve pressure. There can be a danger of ejection of the pressurised fluid at high temperatures. The check must be carried out with the machine parked on level ground with the engine stopped and the equipment on the ground.

- McCONNEL ROBOMAX -

—9.10.2 - FUEL LEVEL CHECK

The fuel level is checked visually on the display with the machine on level ground and with the ignition key in the “ON” position. If the level falls to reserve, the indicator light on the dashboard lights up and an audible warning will be heard. To top up the fuel, open the cap with the key, loosen the fuel tank cap (a) and refill. Do not fill to the top of the tank; leave space for expansion. Lock the cap with the key.



DANGER:



When refuelling, avoid spillages of fuel as there is a danger of fire. If fuel is accidentally spilled, clean the soiled area thoroughly. Fuel is highly inflammable, do not use naked flames and do not smoke during this operation. Always keep filling nozzle of the tank in contact with the fuel filler to avoid sparks. Use protective clothes when refuelling.

—9.10.3 - ENGINE OIL LEVEL CHECK

The level of the engine oil can be checked on the dipstick (a); the level must be between the MIN. and MAX. marks.

The engine oil level must be checked with the engine cold and with the machine parked on a horizontal surface.

If the level of the engine oil is near the MIN. mark, top it up by unscrewing the cap (b) and adding oil until the level is between the MIN. and MAX marks.

To check this during topping up, wait a few seconds before carrying out the check.

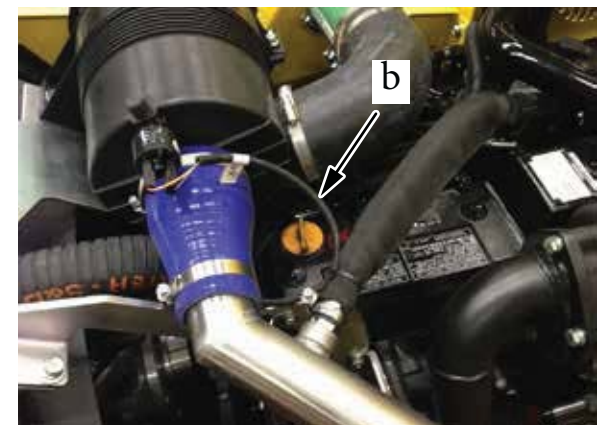
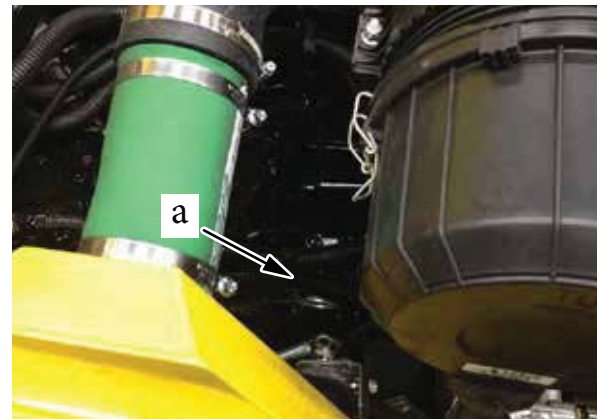

DANGER:



When the engine has just been switched off it may be very hot; therefore, do not check the engine oil until the engine has cooled down. Always wear protective clothing when checking the oil level or topping it up.

- McCONNEL ROBOMAX -

9.10.4 - HYDRAULIC OIL LEVEL CHECK

The hydraulic oil level is checked visually via the level gauge (a) on the side of the tank.

To check the oil the machine must be parked on level ground.

If the oil level is close to the bottom of the level or not even visible, top up as soon as possible.

To top up the hydraulic circuit oil tank, unscrew the cap using the special spanner and top up with oil until the correct level is reached.

Close the cap.

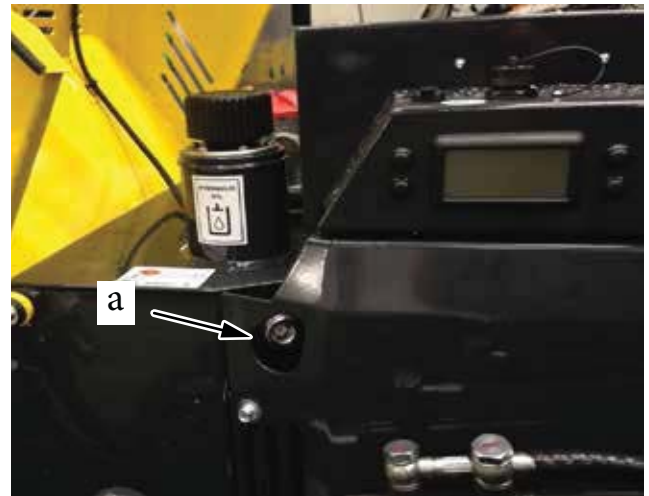

WARNING:

Do not add oil beyond the MAX level; this situation could lead to leaks from the tank. Restore the level only using the hydraulic oil shown in the table (see 9.4).

When using biodegradable oil Panolin HLP Synth E, avoid mixing it with other oils.

The use of non recommended lubricants and/or grease results in the forfeiture of the warranty.

DANGER:



Restore the oil level of the hydraulic circuit after turning off the diesel engine and having closed all ram cylinders. Use protective clothes when topping up.

- McCONNEL ROBOMAX -

—9.10.5 - DRAINAGE OF THE WATER/FUEL SEPARATOR

If you notice the presence of condensation water inside of the fuel separator (a), perform drainage of the separator.

To drain, close the supply valve (b) and open the vent plug (c) until all the water is drained off and clean fuel flows out.

As soon as fuel starts to flow out, tighten the drain plug.

IMPORTANT: Collect the drained water in a suitable container and dispose of it properly.

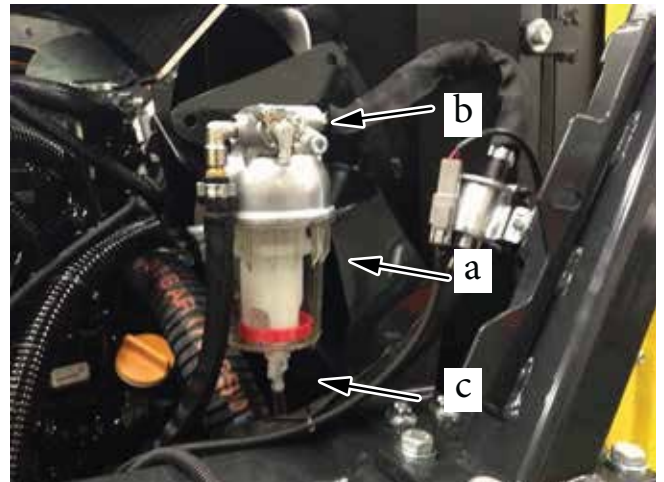

DANGER:



This operation must be carried out with engine off.

Since the fuel is highly inflammable, do not get close with naked flames and do not smoke during this operation.

Clean the area soiled by the fuel immediately.

Wear protective clothing when carrying out this operation.

- McCONNEL ROBOMAX -

9.11 MAINTENANCE EVERY 50 HOURS

9.11.1 - TRACK TENSIONING PRESSURE CHECK

This check must be carried out to preserve and properly maintain the tracks and prevent them from accidentally coming out of their seats.

In order to check the pressure, remove the cover plate, unscrew the cap and screw on the grease gun supplied with the machine. Insert the nozzle of the grease gun onto grease valve (a) and check the pressure obtained on the pressure gauge by injecting grease.

The correct tensioning pressure is 130 bar.

Remove the grease gun, replace the cap and tighten. Close the cover.

Track Tension Kit (Part No. 4000271)

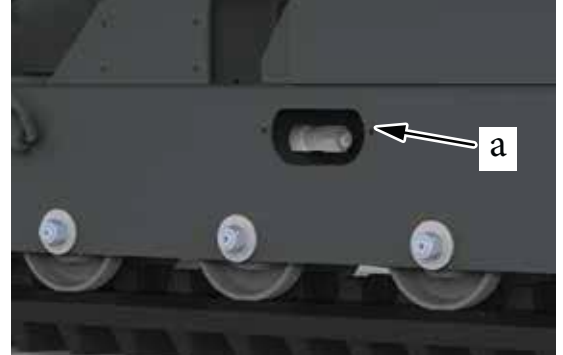

9.11.2 - ELECTRICAL SYSTEM CHECK

This type of check is a visual check that must be carried out with the maximum expertise to avoid short-circuits in the system that would damage the machine.

Specifically check:

- Fuses, if corroded or rusty, replace them with fuses of the same capacity.
- Battery, check the connections on the terminals of the battery, if they are rusty, remove the rust and cover them with appropriate grease: Pay particular attention while performing this operation and avoid contact between the earth cable (black) and the power supply cable (red).
- Starter motor, check the cables.
- Alternator, check the cables.
- Check the tightness of connectors

ATTENTION:



If the cables show signs of damage, overheating, worn insulation etc. try to find out the cause and **CONTACT McConnel Service Department.**

- McCONNEL ROBOMAX -

9.12 - MAINTENANCE AFTER THE FIRST 50 HOURS

The machine is delivered new without running-in, therefore, after the first 50 hours, it is necessary to replace some parts such as:

- Change diesel engine oil and filter.
- Check the coolant level.

9.12.1 - CHANGING THE ENGINE OIL AND FILTER

To change the engine oil, carry out the operations listed below:

- let the engine run for about 5 minutes in order for the oil to become warm.
- position the machine on a level surface, turn off the engine and remove the ignition key.
- remove the lower guard (a)
- open the oil filler cap (b).
- remove the drain plug from the oil sump.
- drain the oil from the bottom whilst it is still warm and collect it in appropriate tanks
- put back the plug of the oil sump once all the oil has drained out.
- turn the filter cartridge (b) using the appropriate wrench and remove it.
- apply a film of clean oil to the new filter seals, both external and internal, and to the thread.
- dry the sealing head of the filter using a dry rag, install the filter and tighten it using the wrench.
- fill the sump using MOBIL SUPER 3000 X1 5W40 engine oil (6.6 l) and close the filler cap.
- Start the engine and leave it running for approximately 5 minutes, turn the engine off and after approximately 3 minutes check the oil level using the dipstick.

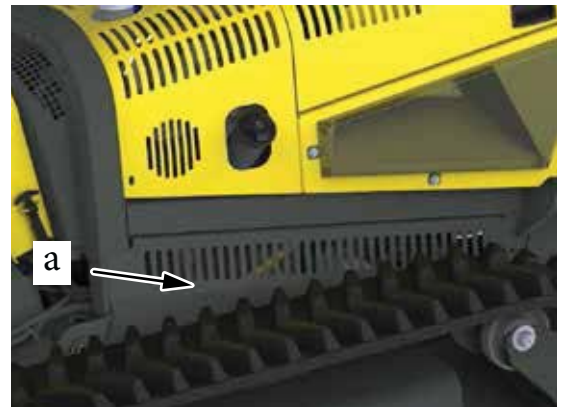

DANGER:



Do not carry out this operation if the engine has just been turned off; wait for the engine to become tepid (40-45°C).

The oil spilled during the change can cause personnel to slip. Wear protective clothing and anti-slip shoes and immediately remove any traces of oil.

Since the oil and filter are considered special waste, they must be disposed of according to the anti-pollution regulations in force.

- McCONNEL ROBOMAX -

9.13 - MAINTENANCE EVERY 250 HOURS

9.13.1 - CHANGING THE DIESEL ENGINE OIL AND FILTER

ATTENTION:



“After the running-in period, change the oil and filter after maximum 250 hours of operation.”

Á

To change the oil follow the procedure in chapter 9.12.1.

9.13.2 - CHANGING THE DIESEL FILTER

- Turn off the fuel supply by via the fuel supply valve (a).
- Place a drip tray under the fuel filter.
- Completely unscrew the water drain valve (b).
- Also completely unscrew the fuel filter (c) using a filter wrench.
- Replace and tighten the new fuel filter by hand until the seal is in contact with housing then tighten by another third of a turn.
- Remove the pre-filter and clean it.
- Restore the fuel supply.
- Loosen the bleed screw (d) by approximately one turn.
- Turn the key on the ignition board to position 1 until fuel flows out from the bleed screw without bubbles.
- Start the engine.
- Check the tightness of all the seals.

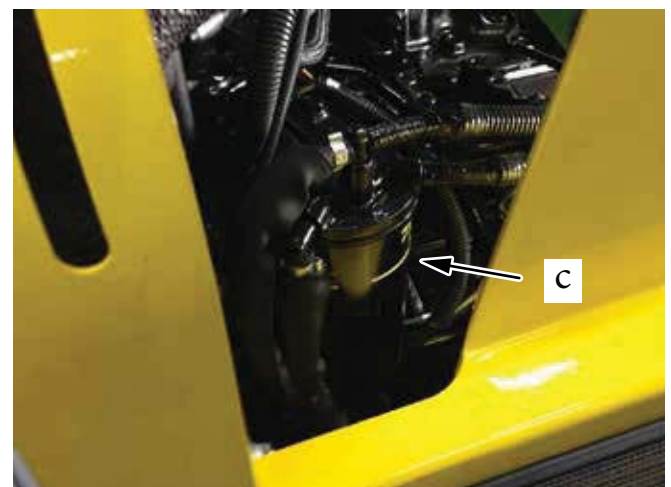
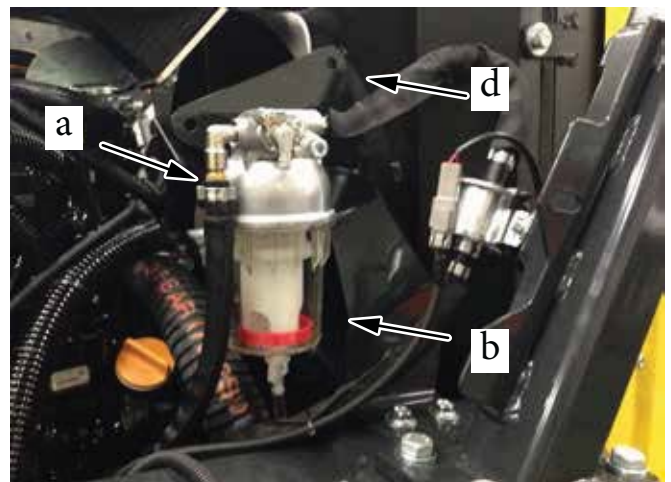

DANGER:



Because fuel is highly inflammable, do not get close to it with naked flames and do not smoke whilst performing this operation.

Clean any area soiled by the fuel immediately.
Wear protective clothing when carrying out this operation.

- McCONNEL ROBOMAX -

9.14 - MAINTENANCE EVERY 500 HOURS

9.14.1 - CHANGING THE HYDRAULIC OIL

The hydraulic oil must be changed at regular intervals in order to ensure proper lubrication and viscosity in the hydraulic pumps.

ATTENTION: Always fill with the same type of oil that was removed. Do not mix different types of oil.

To change the oil proceed as follows:

- Park the machine on a firm level surface and raise it clear of the ground in a safe and stable manner to allow safe access to the underneath.
- Remove the lower guard and thoroughly clean all the parts before opening the filler cap of the oil reservoir.
- Open the filler cap of the oil reservoir (a).
- Remove the reservoir drain plug (b) (10mm wrench), carefully collect the used oil in a large container (at least 100 litres).
- Replace and tighten the drain plug.
- Fill with new hydraulic oil of the correct type (Approx. 70 litres)
- Check the level on the level gauge (c)
- When the correct level of oil is reached, start the engine and leave it running for 10 seconds; repeat the operation until the boost pressure is reached (20-22 bar) on the pumps.
- Turn the engine off again and recheck oil level.
- If necessary, top up the oil until the correct level is reached.

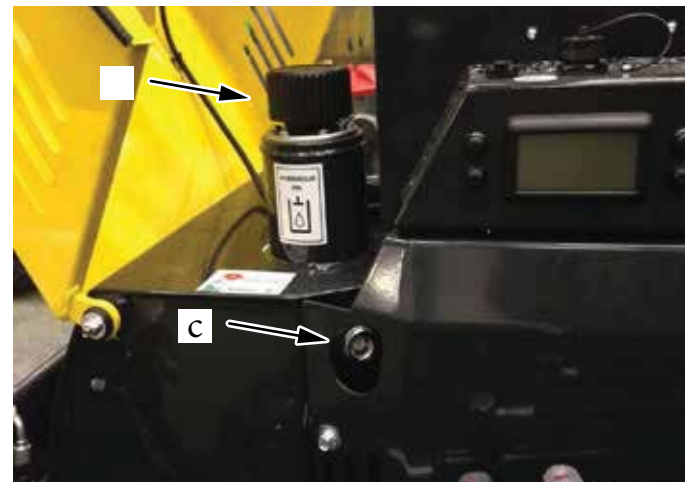
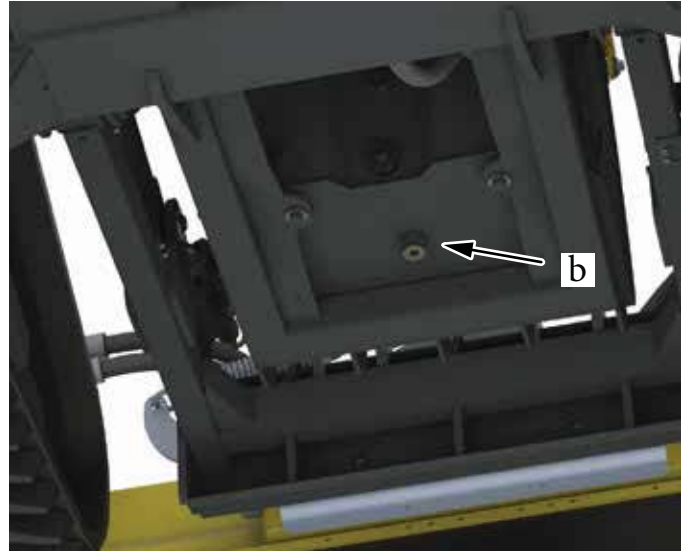

DANGER:



The check must be carried out with the machine switched off, and any attached equipment rested on the ground; the oil must be cold.

The machine must be on a solid and level site.

- McCONNEL ROBOMAX -

9.14.2 - CHANGING THE HYDRAULIC OIL FILTER

1. Unscrew the red cap on top of the filter (1)
2. Extract the filter element by pulling the cap
3. Filters should only be replaced with original filters and before they become completely clogged.
4. Close the cap and tighten with wrench.
Max. torque: 20 Nm.

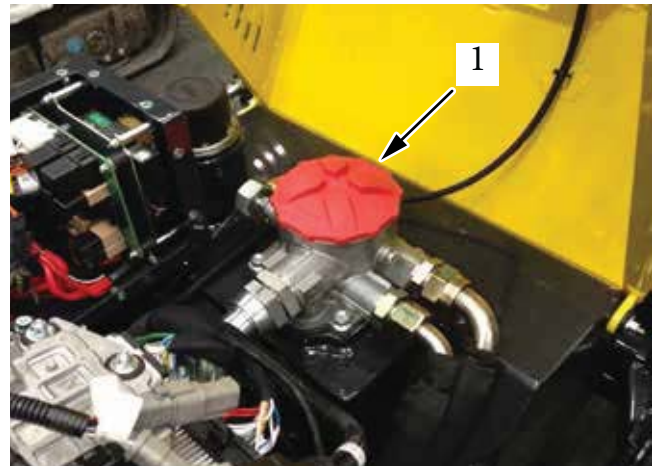

DANGER:



Do not carry out these operations if engine has just been switched off. Wait for the oil to cool (40-45°C).

The oil spilled during the change can cause personnel to slip. Wear protective clothing and anti-slip shoes. Immediately remove any traces of spilt oil.

Since the oil and filter are considered special waste, they must be disposed of according to the anti-pollution regulations in force.

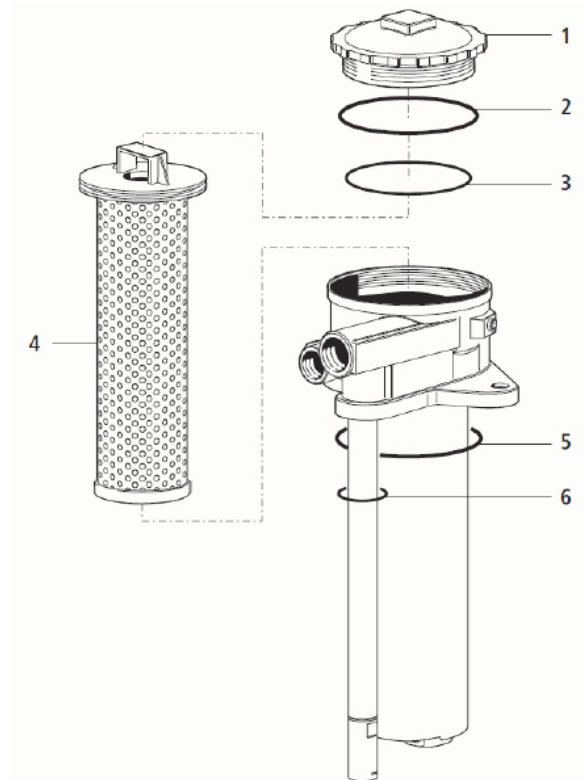

9.15 - MAINTENANCE EVERY 1000 HOURS

9.15.1 - REPLACING THE COOLANT

To replace the coolant, follow the steps below:

- Position the machine on a flat surface and turn off the engine.
- Loosen the radiator cap (a) slowly in order to discharge any residual pressure.
- Unscrew the drain plug (b) and collect the liquid in suitable containers.
- Once all the liquid has been drained, tighten the drain plug.
- Fill the radiator via the filler cap until the fins of the radiator are covered, making sure that bubbles do not form during filling.
- Close the radiator cap.
- Fill the reserve tank from the top cap up to the level indicated by the reference marks (c). Replace the cap.
- Start the engine and leave it running until it reaches normal working temperature.
- Re-check the fluid level in the reserve tank and if necessary top it. Do not fill over the maximum mark.

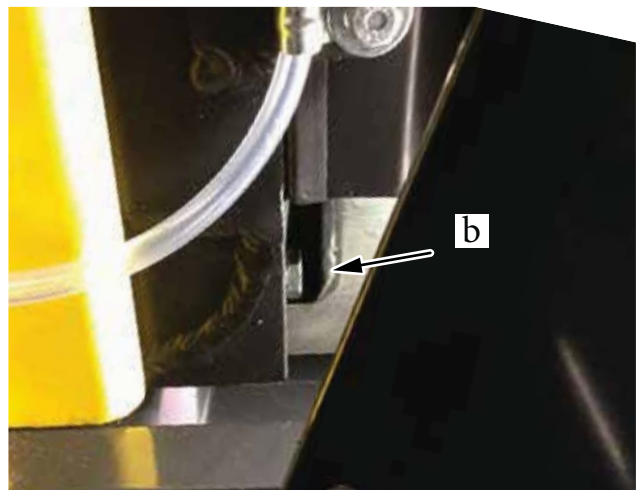

DANGER:



Explosive release of fluids from pressurised cooling system can cause serious burns. Stop the engine. Only remove the filler cap when the engine is cold or when it is cool enough to touch with bare hands. Before removing the cap, loosen it slowly until the first stop to bleed the pressure. Improper disposal of waste can threaten the environment and nature. For the correct disposal or recycling of waste, refer to the appropriate Agencies

- McCONNEL ROBOMAX -

10 - INSTRUCTIONS FOR EMERGENCY SITUATIONS

—10.1 - FIRE

In case of fire, use a fire extinguisher according to the standard regulation in force.
In cases where the machine is on fire or it is near a fire, raise the alarm and contact the Fire Service.

- McCONNEL ROBOMAX -

11 - NOTES



McConnel Limited, Temeside Works, Ludlow, Shropshire SY8 1JL. England.
Telephone: 01584 873131. Facsimile: 01584 876463. www.mcconnel.com