

Publication 992
January 2021
Part No. 24214.92
Revision: 08.04.24



McCONEl

ROBOCUT² / RC40

ROBOCUT / T400

REMOTE CONTROLLED TRACTOR UNIT
Operator Manual



IMPORTANT

VERIFICATION OF WARRANTY REGISTRATION



Dealer Warranty Information & Registration Verification

It is imperative that the selling dealer registers this machine with McConnel Limited before delivery to the end user – failure to do so may affect the validity of the machine warranty.

To register machines; log onto <https://my.mcconnel.com> and select 'Machine Registration' which can be found in the 'Warranty' section of the site. **Confirm to the customer that the machine has been registered by completing the verification form below.**

Registration Verification	Serial No. <input type="text"/>
Dealer Name:	
Dealer Address:	
Customer Name:	
Date of Warranty Registration:/...../..... Dealer Signature:	

Note to Customer / Owner

Please ensure the section above has been completed and signed by the dealer to verify your machine has been registered with McConnel Limited.

IMPORTANT: During the initial 'bedding in' period of a new machine it is the customer's responsibility to regularly inspect all nuts, bolts and hose connections for tightness and re-tighten if required. New hydraulic connections occasionally weep small amounts of oil as the seals and joints settle in – where this occurs it can be cured by re-tightening the connection – *refer to torque settings chart below*. The tasks stated above should be performed on an hourly basis during the first day of work and at least daily thereafter as part of the machine's general maintenance procedure.

CAUTION: DO NOT OVER TORQUE HYDRAULIC FITTINGS AND HOSES

Torque Settings for Hydraulic Fittings

Hydraulic Hose Ends		
BSP	Setting	Metric
1/4"	18 Nm	19 mm
3/8"	31 Nm	22 mm
1/2"	49 Nm	27 mm
5/8"	60 Nm	30 mm
3/4"	80 Nm	32 mm
1"	125 Nm	41 mm
1.1/4"	190 Nm	50 mm
1.1/2"	250 Nm	55 mm
2"	420 Nm	70 mm

Port Adaptors with Bonded Seals		
BSP	Setting	Metric
1/4"	34 Nm	19 mm
3/8"	47 Nm	22 mm
1/2"	102 Nm	27 mm
5/8"	122 Nm	30 mm
3/4"	149 Nm	32 mm
1"	203 Nm	41 mm
1.1/4"	305 Nm	50 mm
1.1/2"	305 Nm	55 mm
2"	400 Nm	70 mm

WARRANTY POLICY

WARRANTY REGISTRATION

All machines must be registered, by the selling dealer with McConnel Ltd, before delivery to the end user. On receipt of the goods it is the buyer's responsibility to check that the Verification of Warranty Registration in the Operator's Manual has been completed by the selling dealer.

1. LIMITED WARRANTIES

- 1.01. *All mounted machines supplied by McConnel Ltd are warranted to be free from defects in material and workmanship from the date of sale to the original purchaser for a period of 12 months, unless a different period is specified.*
All Self Propelled Machines supplied by McConnel Ltd are warranted to be free from defects in material and workmanship from the date of sale to the original purchaser for a period of 12 months or 1500 hours. Engine warranty will be specific to the Manufacturer of that unit.
- 1.02. *All spare parts supplied by McConnel Ltd and purchased by the end user are warranted to be free from defects in material and workmanship from the date of sale to the original purchaser for a period of 6 months. All parts warranty claims must be supported by a copy of the failed part invoice to the end user. We cannot consider claims for which sales invoices are not available.*
- 1.03. *The warranty offered by McConnel Ltd is limited to the making good by repair or replacement for the purchaser any part or parts found, upon examination at its factory, to be defective under normal use and service due to defects in material or workmanship. Returned parts must be complete and unexamined. Pack the component(s) carefully so that any transit damage is avoided. All ports on hydraulic items should be drained of oil and securely plugged to prevent seepage and foreign body ingress. Certain other components, electrical items for example, may require particular care when packing to avoid damage in transit.*
- 1.04. *This warranty does not extend to any product from which McConnel Ltd's serial number plate has been removed or altered.*
- 1.05. *The warranty policy is valid for machines registered in line with the terms and conditions detailed and on the basis that the machines do not extend a period of 24 months or greater since their original purchase date, that is the original invoice date from McConnel Limited.*
Machines that are held in stock for more than 24 months cannot be registered for warranty.
- 1.06. *This warranty does not apply to any part of the goods, which has been subjected to improper or abnormal use, negligence, alteration, modification, fitment of non-genuine parts, accident damage, or damage resulting from contact with overhead power lines, damage caused by foreign objects (e.g. stones, iron, material other than vegetation), failure due to lack of maintenance, use of incorrect oil or lubricants, contamination of the oil, or which has served its normal life. This warranty does not apply to any expendable items such as blades, belts, clutch linings, filter elements, flails, flap kits, skids, soil engaging parts, shields, guards, wear pads, pneumatic tyres or tracks.*
- 1.07. *Temporary repairs and consequential loss - i.e. oil, downtime and associated parts are specifically excluded from the warranty.*
- 1.08. *Warranty on hoses is limited to 12 months and does not include hoses which have suffered external damage. Only complete hoses may be returned under warranty, any which have been cut or repaired will be rejected.*
- 1.09. *Machines must be repaired immediately a problem arises. Continued use of the machine after a problem has occurred can result in further component failures, for which McConnel Ltd cannot be held liable, and may have safety implications.*
- 1.10. *If in exceptional circumstances a non McConnel Ltd part is used to effect a repair, warranty reimbursement will be at no more than McConnel Ltd's standard dealer cost for the genuine part.*

- 1.11. *Except as provided herein, no employee, agent, dealer or other person is authorised to give any warranties of any nature on behalf of McConnell Ltd.*
- 1.12. *For machine warranty periods in excess of 12 months the following additional exclusions shall apply:*
 - 1.12.1. *Hoses, exposed pipes and hydraulic tank breathers.*
 - 1.12.2. *Filters.*
 - 1.12.3. *Rubber mountings.*
 - 1.12.4. *External electric wiring.*
 - 1.12.5. *Bearings and seals*
 - 1.12.6. *External Cables, Linkages*
 - 1.12.7. *Loose/Corroded Connections, Light Units, LED's*
 - 1.12.8. *Comfort items such as Operator Seat, Ventilation, Audio Equipment*
- 1.13. *All service work, particularly filter changes, must be carried out in accordance with the manufacturer's service schedule. Failure to comply will invalidate the warranty. In the event of a claim, proof of the service work being carried out may be required.*
- 1.14. *Repeat or additional repairs resulting from incorrect diagnosis or poor quality previous repair work are excluded from warranty.*

NB Warranty cover will be invalid if any non-genuine parts have been fitted or used. Use of non-genuine parts may seriously affect the machine's performance and safety. McConnell Ltd cannot be held responsible for any failures or safety implications that arise due to the use of non-genuine parts.

2. REMEDIES AND PROCEDURES

- 2.01. *The warranty is not effective unless the Selling Dealer registers the machine, via the McConnell web site and confirms the registration to the purchaser by completing the confirmation form in the operator's manual.*
- 2.02. *Any fault must be reported to an authorised McConnell Ltd dealer as soon as it occurs. Continued use of a machine, after a fault has occurred, can result in further component failure for which McConnell Ltd cannot be held liable.*
- 2.03. *Repairs should be undertaken within two days of the failure. Claims submitted for repairs undertaken more than 2 weeks after a failure has occurred, or 2 days after the parts were supplied will be rejected, unless the delay has been authorised by McConnell Ltd. Please note that failure by the customer to release the machine for repair will not be accepted as a reason for delay in repair or submitting warranty claims.*
- 2.04. *All claims must be submitted, by an authorised McConnell Ltd Service Dealer, within 30 days of the date of repair.*
- 2.05. *Following examination of the claim and parts, McConnell Ltd will pay, at their discretion, for any valid claim the invoiced cost of any parts supplied by McConnell Ltd and appropriate labour and mileage allowances if applicable.*
- 2.06. *The submission of a claim is not a guarantee of payment.*
- 2.07. *Any decision reached by McConnell Ltd. is final.*

3. LIMITATION OF LIABILITY

- 3.01. *McConnell Ltd disclaims any express (except as set forth herein) and implied warranties with respect to the goods including, but not limited to, merchantability and fitness for a particular purpose.*
- 3.02. *McConnell Ltd makes no warranty as to the design, capability, capacity or suitability for use of the goods.*
- 3.03. *Except as provided herein, McConnell Ltd shall have no liability or responsibility to the purchaser or any other person or entity with respect to any liability, loss, or damage caused or alleged to be caused directly or indirectly by the goods including, but not limited to, any indirect, special, consequential, or incidental damages resulting from the use or operation of the goods or any breach of this warranty. Notwithstanding the above limitations and warranties, the manufacturer's liability hereunder for damages incurred by the purchaser or others shall not exceed the price of the goods.*
- 3.04. *No action arising out of any claimed breach of this warranty or transactions under this warranty may be brought more than one (1) year after the cause of the action has occurred.*

4. MISCELLANEOUS

- 4.01. *McConnel Ltd may waive compliance with any of the terms of this limited warranty, but no waiver of any terms shall be deemed to be a waiver of any other term.*
- 4.02. *If any provision of this limited warranty shall violate any applicable law and is held to be unenforceable, then the invalidity of such provision shall not invalidate any other provisions herein.*
- 4.03. *Applicable law may provide rights and benefits to the purchaser in addition to those provided herein.*

McConnel Limited



For Safety and Performance...

ALWAYS READ THE BOOK FIRST



McCONEl LIMITED

**Temeside Works
Ludlow
Shropshire
England**

**Telephone: +44 (0)1584 873131
www.mccommel.com**

In line with our policy of constant improvement, this publication will be periodically updated; to ensure you have access to the latest version of this manual please visit the manuals library on our website where an 'up-to-date' version can be referenced online or downloaded.

<https://my.mccommel.com/service/pdf-manuals/pdf-operator-manuals/remote-control-technology-manuals/>

TABLE OF CONTENTS

1 - GENERAL DESCRIPTION	5
1.1 - PRELIMINARY INFORMATION	5
1.2 - TRAINING REQUIRED FROM THE OPERATOR	6
1.3 - WARNINGS ON USE AND STORAGE	6
1.4 - INTRODUCTION	7
1.4.1 - UPDATING THE MANUAL	7
1.4.2 - COPYRIGHT	7
1.5 - WARRANTIES	7
1.6 - RESPONSIBILITIES	8
1.7 - PERMITTED USES	8
1.8 - IMPROPER OR PROHIBITED USES	9
1.9 - RUNNING-IN AND TESTING THE MACHINE	10
2 - MACHINE SPECIFICATIONS	11
2.1 - MACHINE DESCRIPTION	11
2.2 - RULES APPLIED	12
2.3 - MACHINE IDENTIFICATION	13
2.3.1 - MACHINE DIRECTIONS	13
2.4 - NOISE LEVEL	14
3 - SAFETY REQUIREMENTS	15
3.1 - GENERAL SAFETY RULES	15
3.1.1 - GETTING TO KNOW THE MACHINE THOROUGHLY	15
3.1.2 - WEAR PROTECTIVE CLOTHING	16
3.1.3 - USE SAFETY EQUIPMENT	16
3.1.4 - WARNINGS FOR CHECKS AND MAINTENANCE	17
3.1.5 - CHECKING THE MACHINE	17
3.2 - GENERAL PRECAUTIONS	18
3.2.1 - SAFETY WARNINGS	18
3.2.2 - OPERATIONAL SAFETY	19
3.2.3 - SAFETY WHEN USING GRASS MOWING EQUIPMENT	19
3.2.4 - SAFETY REQUIREMENTS FOR THE HYDRAULIC SYSTEM	20
3.2.5 - LOCATION OF THE SAFETY SIGNS	21
3.2.6 - DESCRIPTION OF THE SAFETY SIGNS	22
3.2.7 - PRECAUTIONS REGARDING THE EQUIPMENT	24
3.3 - GENERAL SAFETY RULES	24
3.3.1 - CARE AND MAINTENANCE	24
3.3.2 - SAFETY DURING REFUELLING AND TOPPING UP	25
3.4 - MAINTENANCE PRECAUTIONS	25
3.4.1 - WARNING SIGNS	25
3.4.2 - TOOLS	25
3.4.3 - PERSONNEL	26
3.4.4 - WORKING UNDER THE MACHINE	26
3.4.5 - KEEPING THE MACHINE CLEAN	26
3.4.6 - PERIODICAL REPLACEMENT OF THE MAIN SAFETY COMPONENTS	27
3.4.7 - HYDRAULIC SYSTEM	27

4 - TECHNICAL DATA 28

4.1 - TECHNICAL SPECIFICATIONS 28
 4.2 - MACHINE NAME 31

5 - TERMINOLOGY 33

5.1 - DEFINITION OF THE TERMS USED 33

6 - USE OF THE MACHINE 34

6.1 - PRELIMINARY CHECKS 34
 6.2 - CHECKS TO BE PERFORMED AT THE START OF EACH WORKING DAY 34
 6.2.1 - CHECKING THE CHROME-PLATED PARTS 34
 6.2.2 - DESCRIPTION OF RECEIVER UNIT 35
 6.2.3 - TRANSMITTER DESCRIPTION 36
 6.3 - TRANSMITTER USE 37
 6.3.1 - CONNECTION BETWEEN MACHINE AND TRANSMITTER 38
 6.3.2 - STARTING THE ENGINE 39
 6.3.3 - STOPPING THE ENGINE 41
 6.3.4 - STOPPING THE ENGINE IN AN EMERGENCY 42
 6.3.5 - ENGINE RPM CHECK 43
 6.3.6 - SLOW/FAST TRAVEL SWITCH 43
 6.3.7 - TRAVEL SPEED POTENTIOMETER 44
 6.3.8 - MOVING THE MACHINE FORWARDS AND BACKWARDS 44
 6.3.9 - STEERING THE MACHINE 45
 6.3.10 - STEERING BIAS CONTROL 45
 6.3.11 - LIFTING DEVICE 46
 6.3.12 - HOW TO HITCH UP A TOOL 47
 6.3.13 - OPERATING THE TOOL 49
 6.3.14 - STOPPING THE TOOL 50
 6.3.15 - AUXILIARY FUNCTION (AUX 1) 50
 6.3.16 - AUXILIARY FUNCTION (AUX 2) 51
 6.3.17 - AUXILIARY FUNCTION (AUX 3) 51
 6.3.18 - TRANSMITTER/RECEIVER CONNECTION BUTTON / HORN 52
 6.3.19 - REVERSIBLE FAN 53
 6.3.20 - REMOTE CONTROL DISPLAY 54
 6.3.21 - STATUS LED 54
 6.4 - CONTROL PANEL 55
 6.4.1 - LCD DISPLAY 55
 6.4.2 - WARNING LIGHTS 57
 6.4.3 - MACHINE HOURS COUNTER / MAINTENANCE SCREEN 58
 6.4.4 - ALARMS SCREEN 59
 6.4.5 - INCLINOMETER SCREEN (OPTIONAL) 59
 6.4.6 - CHANGE OPERATION MODE SCREEN (OPTIONAL) 60
 6.4.7 - REGENERATION SCREEN 60
 6.4.8 - FUSES AND RELAYS 61
 6.4.9 - FUSES AND RELAYS OF THE CENTRAL CONTROL UNIT 61
 6.5 - EXHAUST GAS POST TREATMENT SYSTEM 63
 6.5.1 - DPF OVERVIEW (PARTICULATE FILTER) 63
 6.5.2 - MAINTENANCE AND ASSISTANCE FOR THE PARTICULATE FILTER 64
 6.5.3 - RESET REGENERATION 65
 6.5.4 - STATIONARY REGENERATION 65

6.5.5 - FORCED STATIONARY REGENERATION	66
7.1 - FAULTS	68
7.1.1 - DIESEL ENGINE	68
7.1.2 - TROUBLESHOOTING CONTROL UNIT LE70	69
7.1.3 - ELECTRICAL CIRCUIT	72
7.1.4 - HYDRAULIC SYSTEM	72
7.1.5 - DRIVE MOTORS	73
7.2 - WORKING WITH THE MACHINE	74
7.3 - CONTROL STATION – OPERATOR WORK AREA	76

7 - TRANSPORTATION AND HANDLING 77

7.1 - LOADING AND UNLOADING OPERATIONS FOR ROAD TRAVEL	77
7.1.1 - IF THE MACHINE BREAKS DOWN	78
7.2 - USING THE MANUAL CONTROL	79
7.2.1 - MANUAL CONTROL FUNCTIONS	79
7.3 - STARTING THE ENGINE USING AN AUXILIARY BATTERY	80

8 - STORAGE 81

8.1 - DISMANTLING, DECOMMISSIONING	81
--	----

9 - MAINTENANCE 82

9.1 - INTRODUCTION	82
9.2 - GENERAL INSTRUCTIONS	82
9.3 - EXTRAORDINARY INTERVENTIONS	83
9.4 - FLUIDS AND GREASES	83
9.4.1 - TABLE	83
9.4.2 - COOLANT	84
9.4.3 - FUEL	84
9.5 - ENGINE MAINTENANCE	85
9.5.1 - ENGINE OIL LEVEL CHECK	85
9.5.2 - FILTER AND ENGINE OIL CHANGE	86
9.5.3 - COOLANT LEVEL CHECK	88
9.5.4 - COOLANT REPLACEMENT	89
9.5.5 - FUEL LEVEL CHECK	92
9.5.6 - DRAINING AND BLEEDING THE FUEL SEPARATOR	93
9.5.7 - PRIMARY FUEL FILTER REPLACEMENT	94
9.5.8 - REPLACING THE FUEL FILTER	96
9.5.9 - CLEANING OR REPLACING AIR FILTERS	98
9.5.10 - CLEANING THE RADIATOR CASING AND THE RADIATOR	100
9.6 - HYDRAULIC SYSTEM MAINTENANCE	101
9.6.1 - HYDRAULIC OIL LEVEL CHECK	101
9.6.2 - CHANGING THE HYDRAULIC OIL FILTER	102
9.6.3 - CHANGING THE HYDRAULIC OIL FILTER	103
9.7 - MAINTENANCE OF THE HYDRAULIC MOTORS AND HYDRAULIC VALVES	104
9.8 - CHECKING AND MAINTAINING THE ELECTRICAL SYSTEM	104
9.8.1 - V-BELT INSPECTION/TENSIONING	105
9.8.2 - REPLACING THE V-BELT	106
9.8.3 - CHECKING THE BATTERY CHARGE	108
9.9 - PERIODICAL REPLACEMENT OF THE SAFETY COMPONENTS	109

9.10 - WHEEL DRIVE MAINTENANCE	110
9.10.1 - CHECKING THE TIGHTNESS OF THE SCREWS	110
9.11 - TRACK MAINTENANCE	111
9.11.1 - CHECKING THE TRACK TENSION PRESSURE	111
9.11.2 - REPLACING THE TRACK	113
9.11.3 - ROLLER WEAR	114
9.12 - GREASING THE LIFTING DEVICE	114
9.12.1 - CHECKING THE CHROME-PLATED PARTS	114
9.13 - MAINTENANCE OPERATIONS	115
9.13.1 - MAINTENANCE FREQUENCY	115

10 - INSTRUCTIONS FOR EMERGENCY SITUATIONS 116

10.1 - FIRE	116
10.2 - ASSISTING THE OPERATOR IN CASE OF ILLNESS	116
10.3 - MANUAL BRAKE RELEASE & TOWING	117
10.4 - TOWING	118

11 - TIGHTENING TABLES 119

11.1 - SCREW TIGHTENING TABLE	119
11.2 - FITTINGS TIGHTENING TABLE	119

12 - NOTES 120

1 - GENERAL DESCRIPTION

1.1 - PRELIMINARY INFORMATION

This is the machine use and maintenance instruction manual and is compliant under:

- Directive Machine 2006/42/EC and subsequent amendments and additions.
- Statutory instruments 2008 No. 1597.

Do not destroy or modify it and only supplement it with additional files.

Publication: **992**
Part No.: **24214.92**
Issued: **01/2021**
Machine type: **Remote-controlled, self-propelled machine**
Model: **RC40/T400**

The manual is valid from serial number: **M2165985**

McConnel Limited, Temeside Works, Ludlow, Shropshire, SY8 1JL, UK

Tel: +44 (0)1584 873131 Email: sales@mcconnel.com Website: www.mcconnel.com

AS SUPPLIED (Hood Ram Spacer)

The flail head is fitted with a hydraulic ram to allow movement of the hinged hood. The movement of this ram is restricted with an internal spacer. This is to stop operators inadvertently opening the hood when cutting alongside the highway. This reduces the risk of passing traffic from being hit by objects ejected at speed from the working flail head. It should be noted that with the hinged hood opened objects could be thrown a considerable distance. Being struck by a thrown object could result in injury or death.

If the machine is being used away from the highway, other vehicles and bystanders are not normally in the vicinity then the spacer can be removed provided the general safety information and specific following conditions are met;

- **A detailed work area and bystander risk assessment is undertaken before work begins.**
- **The operator has been trained in the safe use of the Robocut, including safe retrieval of the unit from any situation where it could become stuck or trapped.**
- **The hydraulic ram is returned to the approved version after usage away from the highway and before the re-sale to another party.**

DANGER

Machines are supplied pre-fitted with an internal ram spacer to prevent inadvertent opening of the hood when working in the vicinity of highways and public areas – the ram spacer must be fitted at all times when operating the machine in these types of areas.



1.2 - TRAINING REQUIRED FROM THE OPERATOR

Reading this manual thoroughly:

- All machine maintenance personnel must read this entire manual thoroughly and pay maximum attention to its requirements.
- The employer has an obligation to ensure that the operator possesses the required abilities to operate the machine, and that they have read this manual.

1.3 - WARNINGS ON USE AND STORAGE

The Operating instructions contained in this manual are valid exclusively for the McConnel **RC40/T400**.

This instruction manual must be read and used as follows:

- Carefully read the instruction manual and consider it an integral part of the machine;
- The instruction manual must be readily accessible by the personnel assigned to operate it and to perform maintenance on it;
- This manual should be kept for the entire service life of the machine;
- Make sure that any received update is incorporated into the text;
- Pass on the manual to any other user or subsequent owner of the machine;
- Use the manual in such a way as not to damage it;
- Do not remove, tear, or rewrite any parts of the manual for any reason;
- Keep the manual in a place protected from moisture and heat;
- If the manual is lost or partially damaged and it is no longer possible to read its contents either partially/completely, it is advisable to request a new manual from the manufacturer.

Pay maximum attention to the following symbols and to their meanings. They serve to highlight particular information such as:

WARNING

With reference to additions or suggestions for the correct use of the machine.

ATTENTION

With reference to dangerous situations that can occur when using the machine and which could cause severe injury to people or damage to property.

DANGER

With reference to dangerous situations that can occur when using the machine and which could cause severe injury or death if not avoided.

1.4 - INTRODUCTION

The service instructions outlined in this manual are an integral part of the machine supply contract. These instructions are also addressed to operators already specifically trained to operate this kind of machinery and contain all the information necessary and essential for safe operation and for the correct/optimal use of the machine. Hurried and incomplete preparations may lead to improvisation and this is the cause of many accidents;

Before starting work, carefully read and thoroughly observe the following advice:

- Become familiar confident with all permissible operations and operating positions before starting to operate the machine;
- The operator must always have the instruction manual available at all times;
- Plan each intervention carefully;
- Obtain all the information necessary for machine road transport, such as distance, itinerary, height of level crossings, height of bridges, etc.;
- Be knowledgeable about where and how the machine should be operated: ground bearing weight, necessary outreach, mobility limitation due to the presence of buildings, power lines and similar;
- Before starting to work, make sure that the safety devices are working properly and there is no uncertainty regarding their operation; if this is not the case, do not use the machine under any circumstances;
- When travelling by road, respect all the regulations and requirements in force on road traffic circulation;
- Carefully read the warnings relating to special hazards contained in this manual;
- Constant and thorough preventive maintenance always guarantees high operational safety of the machine. Never put off necessary repairs and ensure they are performed exclusively by specialised personnel, using only original spare parts.

1.4.1 - UPDATING THE MANUAL

The information, descriptions and illustrations contained in this manual reflect the state of the art at the time the machine was marketed.

The manufacturer reserves the right to make changes to the machines at any time for technical or commercial reasons. In the event that such changes are made, the manufacturer has no obligation (for safety reasons) to modify the other machines sold up to that point or to send updates for the manual. Moreover, this publication shall not be considered inadequate. Any additions that the manufacturer deems appropriate to provide as a result of the changes made must be kept with the manual and considered an integral part thereof.

1.4.2 - COPYRIGHT

The copyright of this manual belongs to the machine's manufacturer. This manual contains technical texts, drawings and illustrations which may not be divulged or transmitted to third parties, in whole or in part, without the written authorisation of the machine manufacturer.

1.5 - WARRANTIES

The parts supplied by McConnel are covered by a 12-month warranty, that becomes valid upon commissioning, proven by the documentation delivered to the customer. In any case, refer to the machine order confirmation or to any specific agreements entered into during the sale. McConnel shall repair or replace parts recognised as defective during the warranty period (see attached service log).

By replacing the defective part, McConnel shall consider itself free from any other expenses borne by the Dealer and the Dealer's Customer, for instance alleged damage, either present or future, such as lost earnings, conventional penalties, etc.

Ordinary and extraordinary maintenance must be performed in accordance with the instructions contained in this manual. For all cases not included and for every type of assistance, contact McConnel directly by registered letter or fax, even in the case of agreements made by telephone. McConnel shall not be held responsible for any delays or missed interventions. McConnel shall not be held responsible for any damage or malfunctions due to technical operations carried out on the machine by unauthorised personnel.

1.6 - RESPONSIBILITIES

McConnel considers itself exempted from all liability and obligations for accidents involving personal injuries or damage to property which may occur due to:

- Failure to observe the instructions given in this manual to run, operate and perform maintenance on the machine;
- Abrupt actions or incorrect manoeuvres when operating or performing maintenance on the machine;
- modifications made to the machine without prior written authorisation from McConnel;
- Any other events that cannot be considered normal and correct use of the machine.

In any case, whenever the user blames the accident on a defect of the machine, it is necessary to prove that the consequent damage was a main and direct consequence of such defect.

Any tampering or the use of non-original spare parts will create the conditions for voiding the warranty and put the operator's safety at risk.

ATTENTION



- **For repairs or maintenance always make exclusive use of original spare parts.**
- **McConnel declines all liability for any damage that may be caused as a result of non-compliance with the above.**
- **The machine is guaranteed according to the contractual agreements entered into upon sale.**
- **The warranty, however, will not apply if the rules and instructions of use contained in this manual have not been complied with.**

1.7 - PERMITTED USES

RC40/T400 is a machine manufactured for use by professional personnel. The machine is a self-propelled radio-controlled vehicle that can be used in the agricultural sector, with the possibility of attaching different tools to the front lifting equipment, as well as in the forestry sector.

RC40/T400 (hereinafter referred to as "machine") and the tools are not toys, but a PROFESSIONAL MACHINE. Always respect the conditions of use specified by the producers of the machine. The machine is suitable for performing flail mowing operations at a speed of up to 4-5 km/h, depending on the conditions of the ground and the type and condition of material to be cut (length, whether dry or wet, density etc.) and on slopes having a maximum inclination of 55°.

This machine is generally used during daylight hours. If, under exceptional circumstances, it has to be used at night or in conditions of reduced visibility, an auxiliary lighting system must be used. Operate in daylight or with artificial lights which guarantee a visibility of at least 100 metres.

1.8 - IMPROPER OR PROHIBITED USES

ATTENTION



With reference to dangerous situations that can occur when using the machine and which could cause severe injury to people or damage to property.

WARNING



This paragraph indicates some of the improper or unauthorised uses; as it is impossible to foresee all possible improper uses, if there are particular occasions of use of the machine not contemplated among those permitted, consult McConnel before carrying out the work.

The following uses must always be strictly avoided:

- Use of the machine by minors, inexperienced, untrained, or unlicensed persons;
- Using the machine to lift people or objects;
- Using the flail mower head as a piledriver;
- Using the machine to tow damaged vehicles;
- It must not be used on surfaces contaminated by glass, loose stones, pieces of iron or other extraneous bodies that could be kicked up by the blades of the tool;
- Lifting or pulling tilted loads;
- Placing accessories or equipment classified as dangerous due to their chemical or physical properties (e.g. flammable, toxic, explosive materials etc.) on the machine;
- Overloading the machine beyond its permitted limits;
- Increasing the working length with booms without the authorisation of McConnel;
- Using the machine with equipment not authorised by McConnel;
- Making changes to the machine (hydraulic, electrical, or mechanical);
- The machine must not be used on public roads.

Range of action means an area that should be free of people, as it could be hazardous. To this end, also consider what is indicated in the manuals of the individual pieces of equipment and the different operating modes used.

DANGER



If the machine is used in the ways specified above, there will be the risk of overturning or structural breakage of the same, with the consequent risk of injury or death of the operator.

1.9 - RUNNING-IN AND TESTING THE MACHINE

Each machine is carefully adjusted and tested before delivery.

A new machine must however be used with caution for the first 100 hours for the purpose of the efficient running-in of the various components.

If the machine is subjected to an excessive work load during the initial phase of operation, its potential performance will be prematurely compromised, and its functionality reduced in a short period of time.

During the running-in period, pay close attention to the following points:

- After start-up, let the engine run at a low speed for 5-6 minutes;
- Avoid running the machine at the maximum speed for the first 100 hours of operation. Avoid sudden accelerations or decelerations.

Refer to the service booklet attached for the various types of maintenance to be carried out. Also refer to the engine manual and to the equipment manual for any type of work that has to be carried out.

ATTENTION

When replacing oil and diesel filters, inspect them internally to check if there are any deposits. If there are, check for possible causes before restarting the machine.

2 - MACHINE SPECIFICATIONS

2.1 - MACHINE DESCRIPTION

Multi-purpose operating machine, specific for grass mowing, shrubs, grass maintenance of roadsides, embankments, etc.

Equipped with hydraulic attachments with quick screw couplings which allow the replacement of various equipment depending on the operational needs.

The machine has a multi-purpose lifter that allows all the equipment allowed by McConnel to be connected.

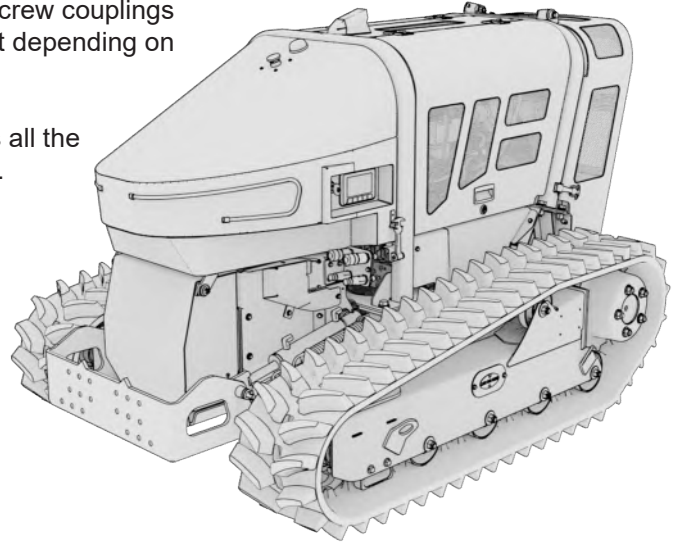

PERMITTED EQUIPMENT

All the equipment validated by McConnel and listed here, does not alter the stability of the vehicle, including the equipment, up to the permitted gradient (both for equipment with and without ballast).

McConnel declines all responsibility for damage of any kind caused by improper use or use other than that described above.

The approved equipment enables the machine to remain stable at the maximum permitted gradients.

- CUTTING HEAD
- MOWER BAR
- ROTARY MOWER
- TRENCHER
- ROTARY HARROW
- ROTARY TILLER
- RAKE
- LAND BLADE
- SNOW BLADE
- WINCH

Ballast weights should be applied when using the following equipment:

- FORESTRY HEAD (rotary hammers)
- BIO-SHREDDER;
- FRONT LOADER BUCKET;
- BUCKET
- FORKS
- GRAPPLE BUCKET
- SNOW BLOWER
- TREE SHAKER
- FORESTRY WINCH

2.2 - RULES APPLIED

This machine has been designed and built in compliance with EC directives on safety and the approximation of the laws of the Member States;

Specifically, the Machinery Directive 2006/42/EC, where applicable and S.I. 2008 No. 1597.

The following standards were also taken into account during the design phase:

- UNI EN ISO 12100:2010 "Safety of machinery" (terminology);
- EN 60204-1:2016 "Safety of machinery" (Electrical equipment);
- 2014/30/EU Electromagnetic compatibility;

The following harmonised standards were used for updating the machine:

- ISO 12100:2010
- EN ISO 4254-1:2015
- EN ISO 4254-12:2018

As well as the following technical specifications:

- UNI EN ISO 3767-1:2016;
- ISO 11684:1995;

2.3 - MACHINE IDENTIFICATION

The machine's identification plate is fixed to the left or right-hand side of the chassis, on the outside of the side member.

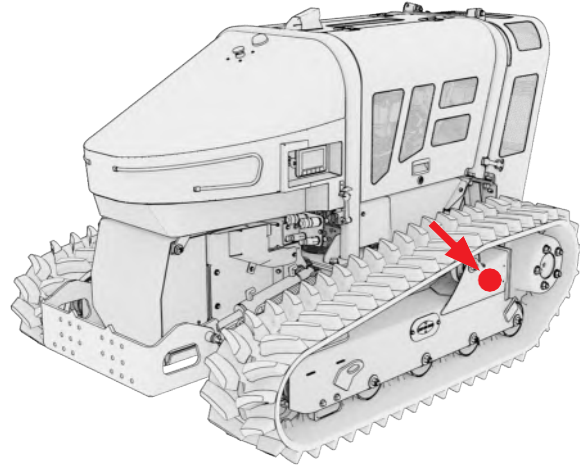
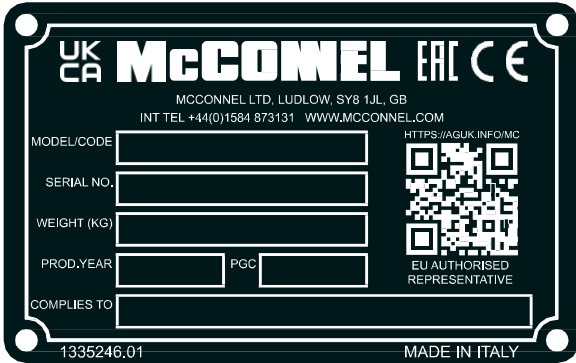

WARNING



The serial number and year of manufacture must always be indicated in assistance requests and spare parts orders.

2.3.1 - MACHINE DIRECTIONS

Left or right means with respect to the forward direction of movement.

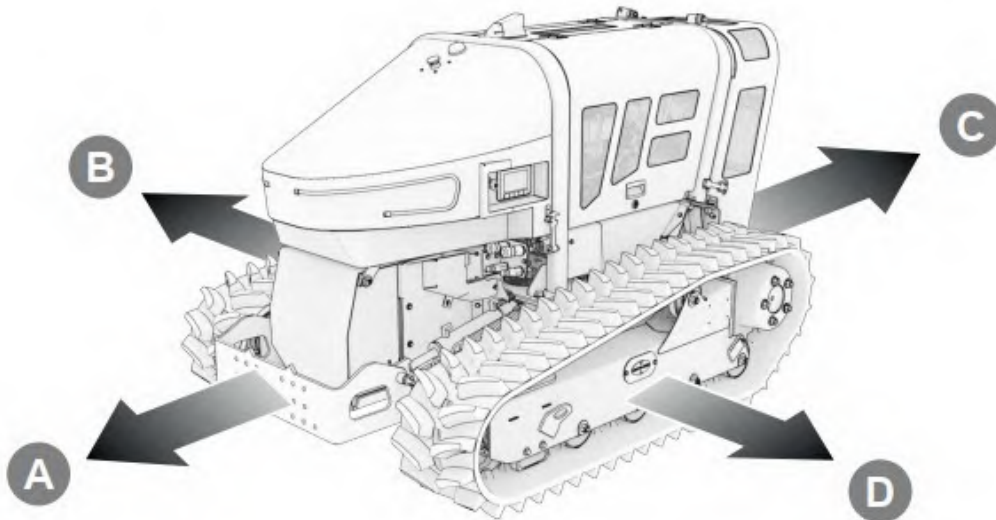

2.4 - NOISE LEVEL

LpA = This value indicates the maximum sound level perceived by the operator calculated by making a worst case assessment at the 4 points around the machine being tested.

Lwa = This value indicates the sound level outside the machine and refers to the noise perceived by those who are in the vicinity of the work area.

Standards:

- S.I. 2008 No. 1597

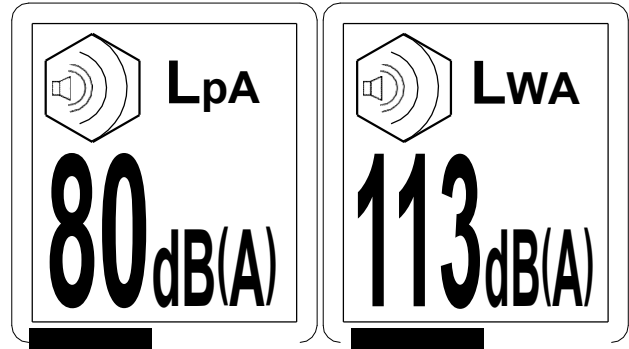

Moreover, the **LpA** values have been taken at greater distances, resulting in 89 dB(A) at five metres and 80 dB(A) at thirty metres.

ATTENTION



ALWAYS WEAR PROTECTIVE EARMUFFS AS THE MEASURED NOISE VALUES REQUIRE NOISE PROTECTION DEVICES TO BE USED.



3 - SAFETY REQUIREMENTS

3.1 - GENERAL SAFETY RULES

ATTENTION



- Stickers are applied to the machine to ensure safer use. They must be replaced if they are no longer legible.
- The operator must never be an occasional worker but must have some experience with this type of machine.
- If the direct view of the work area from the driving position is not sufficient, the operator must be assisted by an expressly appointed person.
- Check the condition and operation of any part subject to wear on a monthly basis: (pins, valves, piping etc.). Where necessary, replace them with original parts.
- Never, under any circumstances, tamper with the hydraulic system and in any case do not remove the seal from the valves as this would invalidate the warranty. To adjust the valves, contact an authorised workshop.
- Excessive heating of the oil causes damage to the gaskets of the hydraulic circuit and deterioration of the fluid itself. Heating is caused by lamination of the oil through the maximum pressure valve. For this reason, avoid extended operation with the jacks at the end of the stroke.
- It is also necessary to check that the machine emergency button and remote control stop button are working correctly. If the emergency or stop buttons are damaged, the machine must not be started up or its operation must be stopped immediately.
- The machine user is responsible for all property damage or personal injuries caused by machine operation.
- Maintenance, cleaning, adjustments or similar operations on any part of the machine or interchangeable equipment connected to it are strictly forbidden when the machine is moving. Any maintenance, cleaning or adjustments must always be performed with the engine off.
- It is forbidden to remove or alter the guards protecting moving parts or hot surfaces of the machine, or interchangeable equipment connected to it.

3.1.1 - GETTING TO KNOW THE MACHINE THOROUGHLY

The machine must be used only by qualified personnel, who must be familiar with the location and the function of all its controls, tools, indicators, indicator lights and plates.

3.1.2 - WEAR PROTECTIVE CLOTHING

Wear tight fitting clothing and use personal protective equipment in accordance with current regulations. In particular, they are required to wear:

- Noise protection headphones;
- Safety footwear;
- Overalls;
- Work gloves.

During use, the machine may produce dust emissions. If working with dry products (straw or stretches of bare earth) it is advisable to use protective devices such as:

- Eye protection goggles;
- Respiratory dust masks.



3.1.3 - USE SAFETY EQUIPMENT

- A first aid kit should be on hand when the machine is in use;
- A powder type fire extinguisher should be on hand when the machine is in use so that you can take action quickly in case of an emergency;
- Always make sure that the extinguisher is full;
- Use the extinguisher according to current regulations;
- Be prepared to fight a fire and / or handle an emergency;
- Have the numbers of emergency services at hand:
 - Doctors;
 - Ambulances;
 - Hospital;
 - Fire fighters.



- **The owner of the machine and/or employer is responsible for providing a fire extinguisher and a first aid kit and for periodically making sure that they are in good order.**
- **A CO² fire extinguisher is specific for extinguishing fires of an electrical nature.**

We recommend using a powder fire extinguisher on the machine in general.

3.1.4 - WARNINGS FOR CHECKS AND MAINTENANCE

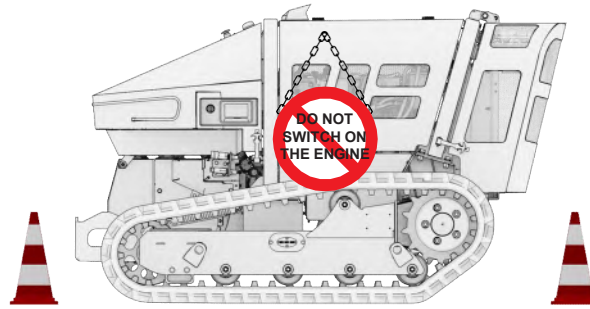

Apply a “DO NOT START THE ENGINE” sign to the machine. Remove the keys from the ignition before carrying out checks or maintenance work and delimit the area (for example with road cones).

3.1.5 - CHECKING THE MACHINE

- Carefully inspect the machine every day before use, following the checklist given in this manual.
- Start the engine only in well ventilated areas and make sure that there are no people within the operating range of the machine.
- Covers and safety elements must not be removed. They are designed and built for your safety.
- Do not use the machine if the protective devices or covers are damaged or missing.
- After cleaning or repair the protective devices must be reapplied immediately.
- Keep the machine and all its accessories clean and in good working order at all times.
- It is strictly forbidden to make changes to the machine without prior authorisation from the manufacturer. Changes to the machine can in fact cause hazards and injuries. If these instructions are not observed, the manufacturer assumes no responsibility for the machine.
- Only refuel when the machine is switched off, if possible before having turned it on, and when the fuel tank is cold. If you need to refuel whilst work is in progress, do not add fuel to the tank if the tank is hot or if the engine is still warm. Allow the machine to cool down.

Range of action means an area that should be free of people, as it could be hazardous. To this end, also consider what is indicated in the manuals of the individual pieces of equipment and the different operating modes used.

DANGER



DANGER OF EXPLOSION OR FIRE

During normal daily maintenance do not clean with high pressure water (pressure washer) electrical components, such as:

- Receiver unit and remote control;
- Fuse box and relays;
- Engine control unit and the machine ECUs;

Apply a guard or cover with appropriate means before washing so as to isolate the electrical components.

3.2 - GENERAL PRECAUTIONS

- It is mandatory to read and follow the instructions indicated in the use and maintenance manual before performing any operation or manoeuvre with the machine. It is too late to do so while working. Improper use or an incorrect manoeuvre can result in serious damage to people or property;
- The operators and maintenance technicians must be familiar with the machine, in particular they must know the dangers deriving from incorrect use or incorrect repairs;
- Before starting, carry out all the checks on the machine and equipment such as:
 - Operation;
 - Accident prevention regulations;
 - Guards;
- Even when using the machine correctly, stones or other objects can be projected far away. Therefore, there must be nobody within the danger zone (100 metres). Be very careful when working near roads or buildings;
- Before starting the work, always check the integrity of the tools and of all guards; if damaged or missing, replace them;
- Make sure that nobody can involuntarily start the machine during checks and repairs.
- Do not wear loose clothing;
- Never transport anyone on the machine;
- Never carry persons on the cutting head or on any other mounted equipment;
- Do not stand near the machine until the equipment is at completed standstill;
- Before each start-up, make sure that there are no people and/or animals nearby;
- Before leaving the machine, proceed as follows:
 - Park the machine on a flat surface.
 - Reduce the rpm of the engine before turning it off. Press the remote-control red button and turn the ignition key to the "O" position.
 - Remove the ignition key and take the remote control away with you.
- Immediately replace any lost or worn warning plates or pictograms;
- Never underestimate or ignore safety regulations;
- Go to an authorised workshop if the safety devices are not working.
- Keep the remote control out of the reach of unauthorised personnel and especially children.

3.2.1 - SAFETY WARNINGS

The machine has been designed and built according to the technical requirements in force for operations such as mowing grass, hedges, maintenance of green areas of roadsides, slopes, canals, water drainage, etc. Observe the laws, provisions, requirements, ordinances and directives in force for such machines.

The materials used and the pieces of equipment, as well as the production procedures, quality guarantee and checks meet the highest safety and reliability standards.

Use the machine for the purposes specified in this user manual, operating it with the due diligence and carry out accurate maintenance and revisions as envisaged to obtain the highest performance, continuous operation and ensure a long service life of the machine.

3.2.2 - OPERATIONAL SAFETY

The manufacturer shall not be held responsible in case of malfunction and damage if the machine:

- is used for purposes other than those for which it was intended;
- is not manoeuvred, started and maintained according to the service instructions specified in the following manual;
- is not periodically and constantly placed under maintenance as prescribed or non-original spare parts are used;
- it is modified or its equipment is replaced without the written authorisation of the manufacturer, especially when the efficiency of the safety devices has been reduced or eliminated on purpose;
- it is used outside the permitted temperature range;

3.2.3 - SAFETY WHEN USING GRASS MOWING EQUIPMENT

- Before using the machine, remove from the mowing area all stones, sticks, glass, metal wires, bones, branches, and any other objects that could be collected and tossed around by the flail rotor or that could damage the cutting head.
- Avoid obstacles during machine operation. Do not use the machine near steep slopes, unstable terrain, or areas in which it could tip over.
- When the machine is being used, be very careful not to let it come into contact with hard objects such as drain covers, manhole covers, curbs, guard rails, railway tracks etc. This could cause the tools to break and they could be projected at very high speed.
- Whenever wire, cables, chains, or other objects become caught in the rotor, stop immediately in order to avoid damage or dangerous situations. Stop the rotation of the cutter, switch off the engine and remove the key. After having put on work gloves, reset the rotor with the help of pliers or shears.
- Do not continue to use the machine if there are vibrations from the flail and/or forestry head that could cause breakages or serious damage. Ascertain the cause of the problem and eliminate it.
- During operation, pay attention to the electrical cables, especially if you need to pass under them, as you could lose the radio signal. In these cases, the machine immediately deactivates (disconnects) the commands and stops with the engine running at idle speed.
- Before raising/lowering the equipment with the raiser, make sure nobody is within ten meters of the machine.

DANGER



- Do not try to free the rotor by making it turn in the opposite direction.
- Danger of projection of materials.

ATTENTION



If you are using other equipment, refer to the manual of that equipment.

3.2.4 - SAFETY REQUIREMENTS FOR THE HYDRAULIC SYSTEM

- Stop immediately if you notice oil leaks.
- Periodically check the hoses. If they are worn, contact McConnel. Before working on the system, lay the head on the floor (or any other mounted equipment) and turn off the engine.
- Oils and greases must be disposed of according to anti-pollution standards.

WARNING

- **Never search for oil leaks with bare hands or other body parts; use paper or cloths to locate the leak.**
 - **Always wear waterproof gloves and eye protection.**
 - **Wait until the oil has cooled before intervening.**
 - **Discharge the oil pressure before disconnecting the hoses or when performing maintenance on the system.**
 - **High pressure oil may penetrate the skin and cause serious infections; in such case seek medical attention immediately.**
 - **These interventions must be performed by authorised personnel.**
-

3.2.5 - LOCATION OF THE SAFETY SIGNS

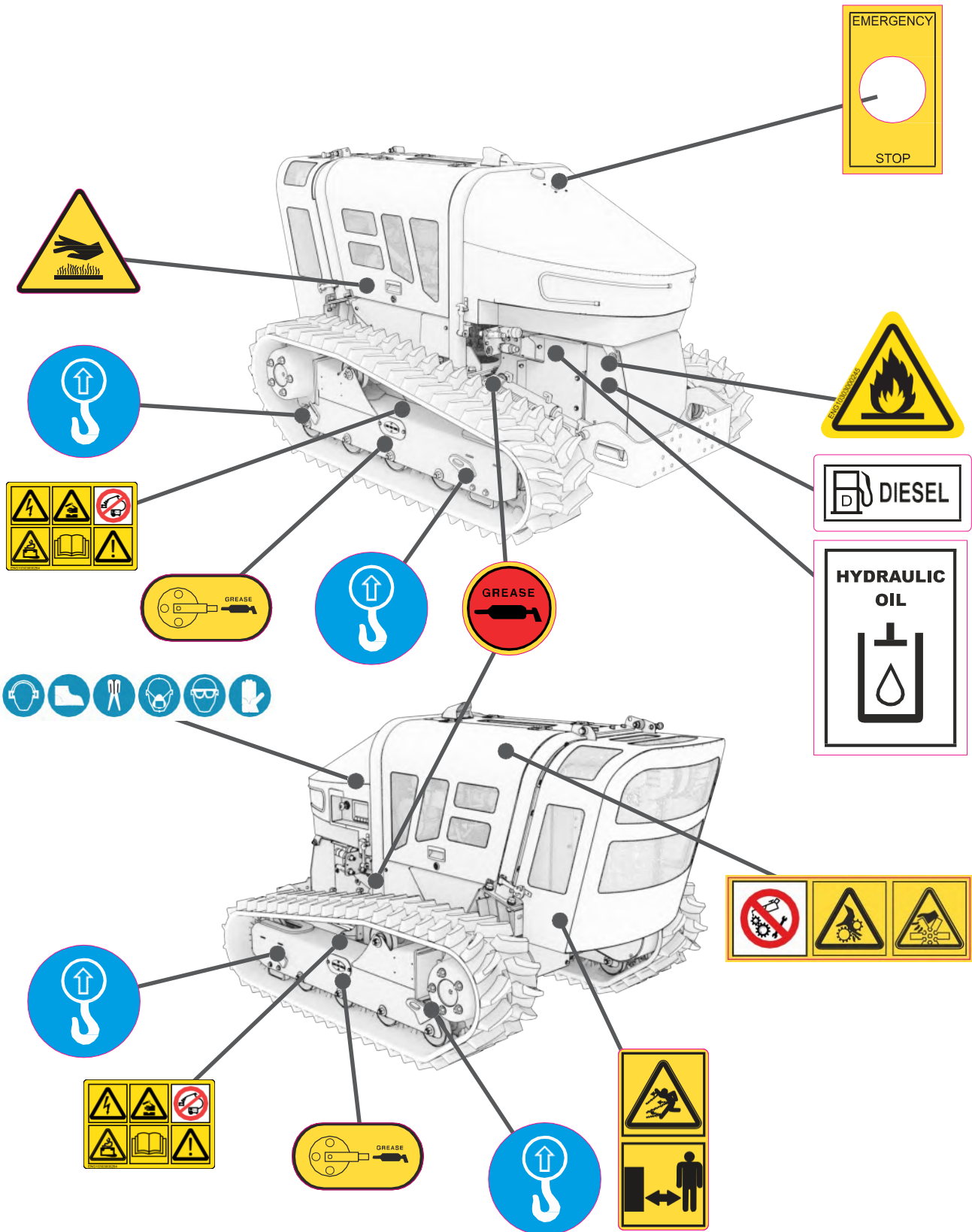

3.2.6 - DESCRIPTION OF THE SAFETY SIGNS

WARNING



Ensure the good condition of the safety pictograms. If the plates are damaged, they must be replaced with original plates that can be requested from McConnell and placed in the position indicated in the manual. Make sure that all safety decals are legible. Clean them using a damp cloth with soap and water.

Hydraulic oil tank

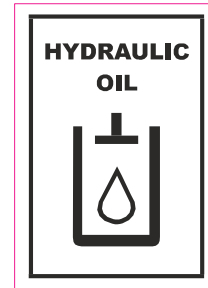

Fuel tank



Hazards associated with the battery

- Keep sparks, lighted matches, and open flames away. Battery gases are explosive.
- Never check the battery charge by connecting the two poles with a metal object. Use an acidimeter or a voltmeter.
- Do not charge a frozen battery: danger of explosion! Warm the battery first to 16°C (60°F).
- Danger of electric discharge.
- Corrosion danger.



To check it, refer to section 9.8 of this manual.

Lifting points provided for handling the machine



Emergency stop button

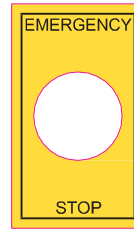

Moving parts danger warning signs

Indicates the presence of moving mechanical parts.

Do not lubricate

Indicates that it is strictly forbidden to lubricate moving parts and that the engine must be switched off.



Hot parts warning sign

Indicates the presence of hot parts such as exhaust pipes or bonnets. Do not touch the areas around the sign.



Personal protective equipment (PPE)

All operators and personnel should be provided with appropriate PPE. In particular, they are required to wear:

- Noise protection earmuffs;
- Safety footwear;
- Overalls;
- Dust mask;
- Protective eyewear;
- Work gloves;

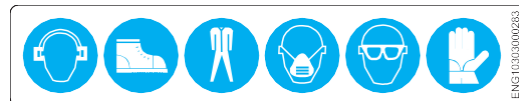

Lubrication zone sign

Indicates the greasing and lubrication points (and possibly the frequency).



Lubrication zone sign

Indicates the greasing point for tensioning the track.

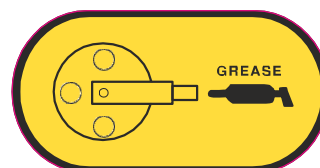

3.2.7 - PRECAUTIONS REGARDING THE EQUIPMENT

- When optional equipment is installed and used, carefully read the relative manual and strictly follow the instructions contained in it.
- Do not use optional or special equipment without having received written approval from McConnell.
- Assembly and use of equipment not authorised by McConnell can compromise safety and cause damage both for the operation and for the duration of the machine.
- Any damage, accident or reduction of efficiency of the machine due to the application and use of unauthorised equipment, does not make McConnell liable.

3.3 - GENERAL SAFETY RULES

3.3.1 - CARE AND MAINTENANCE

The cause of much damage and many accidents can be attributed to mistakes or insufficient maintenance, such as:

- Lack of oil, grease and anti-freeze,
- Lack of cleaning,
- Lack of hydraulic system maintenance (damaged hoses, loose fittings etc.).
- Carry out maintenance works carefully as they are also important for your own safety.
- Never put off repairs.
- Have only specialised or authorised personnel carry out repairs.
- Always observe the following safety requirements, even when you are fully familiar with all the controls:
 - Adapt the speed to the conditions of the travel path.
 - Before beginning work, check that all the movements of the protective devices are functioning properly.
 - Make sure that the emergency stop devices are working correctly (located on the remote control and on the machine).
 - Continually make sure that there are no people in the machine danger area (they must stay more than 100 m away) Shout an alert, sound your horn to warn people and stop work if these people do not leave the danger area.
 - Do not allow anyone to climb onto the machine.
 - Do not use the machine to lift persons.
 - Never leave the machine when it is switched on.
 - If for some reason, the rotor of the equipment begins to shake, stop the equipment immediately and try to understand the reason and / or restore correct operation. McConnell declines all liability for injury to people or damage to property if the operator fails to comply with these instructions.
 - Clean the machine after use. Do not use petrol or solvent-based products to clean the machine.
 - During operation, and in particular in windy conditions, the user must carefully choose his position in order not to be exposed to exhaust gases, dust or mown grass.
 - Do not operate the equipment if you are unable to see it (behind ridges, round corners of buildings, in tall grass etc...).

ATTENTION



- **Due to vibrations, regularly check that all screw connections are firmly tightened.**
- **This check must be carried for the first time after eight hours of operation and repeated at least weekly.**

ATTENTION

- Do not clean electrical parts (for example the fuse box, actuator and control units) with high pressure water.
- Cover electrical parts with a plastic bag to protect them during washing.

3.3.2 - SAFETY DURING REFUELLING AND TOPPING UP

- Fuel, oil and some type of anti-freeze are highly flammable.
- Keep away from naked flames.
- Turn off the engine and do not smoke when fuelling up.
- Fuel up only when the engine is off and in a well-ventilated area.
- Do not let unauthorised persons come near.
- During filling, hold the fuel pump pistol or the jerry can and keep them always touching the fuel filler hole until the filling operation is over to avoid sparks due to static electricity.
- When filling up is complete, tighten the safety device.
- Do not fill the tank completely. Leave some space in order for the fuel to expand.
- immediately dry off any fuel that may have spilled out.

**3.4 - MAINTENANCE PRECAUTIONS****3.4.1 - WARNING SIGNS**

Before performing any maintenance operation, place the machine on solid and level ground, lay the equipment on the ground and stop the engine. If other people start the engine and use the control levers while maintenance is being performed, there is a risk of serious injuries or death. To avoid these dangers, before carrying out the maintenance, put the remote control in a safe position, remove its battery and hang the warning signs on the machine.

3.4.2 - TOOLS

Use only tools indicated by the machine manufacturer to prevent personal injuries, discard worn, damaged, low quality or makeshift tools.

ATTENTION

Tools that are not indicated or modified without authorisation will void the warranty and release the manufacturer from any liability for injury to people or damage to property.

3.4.3 - PERSONNEL

The routine maintenance indicated in the manual must be carried out exclusively by authorised and trained personnel. To perform maintenance on or service components not specified in this manual, please contact McConnel.

3.4.4 - WORKING UNDER THE MACHINE

If it is necessary to carry out maintenance under the machine, make sure that you have all the suitable tools to do so. Lift the machine using the relevant hooks on the lift truck, with suitable ropes or chains (refer to section 7.1 for the lifting operations). Place the machine on suitable supports in a horizontal position.

DANGER

- **Do not climb on or get under the machine when it is raised and not properly supported as indicated in the safety standards.**
- **Make sure that you use cables, chains and lifting means appropriate for the load and for the lifting of objects.**

3.4.5 - KEEPING THE MACHINE CLEAN

The routine maintenance indicated in the manual must be carried out exclusively by authorised and trained personnel. To perform maintenance on or service components not specified in this manual, please contact McConnel.

- **Regularly remove all flammable materials (dry grass and leaves) from the area around the exhaust pipe, engine, battery and all the points in which they can come into contact with oil or fuel and therefore ignite.**
- Clean the machine after use.
- Do not use petrol or solvent-based products to clean the machine. **Do not clean electrical parts with water under pressure.**

3.4.6 - PERIODICAL REPLACEMENT OF THE MAIN SAFETY COMPONENTS

Periodically check the following components, important for fire prevention:

- Supply system: fuel delivery and return pipes;
- Hydraulic system: main delivery pipes of the hydraulic motors;
- Hydraulic system: pipes for utilities from the control valve to the hydraulic cylinders.

Carefully check the state of efficiency and cleanliness of the quick coupling devices supplied with the machine.

Even if they appear to be in a good state, these components have to be replaced periodically with new pieces. Over time, these components in fact tend to deteriorate. In the case that one of these parts is defective, replace or repair it even if it is still not past its expiry date.

3.4.7 - HYDRAULIC SYSTEM

When the machine's engine is switched off, there may be a residual pressure of 2 bar on all its hydraulic systems.

In order to discharge this pressure from the systems for carrying out maintenance, proceed as follows:

1. Lower the lifting device completely;
2. If the cutting head is attached, close the guard;
3. Make sure that the engine has been switched off and that the mechanisms are stationary.
4. Loosen the fittings of the lifter cylinders;
5. Loosen the fittings of the guard-opening cylinder;
6. Loosen the fittings of the drainage lines of the translation and cutting head motors;
7. As regards the control valve, the pressure equalizes with that of the tank;

4 - TECHNICAL DATA

4.1 - TECHNICAL SPECIFICATIONS

DIMENSIONS

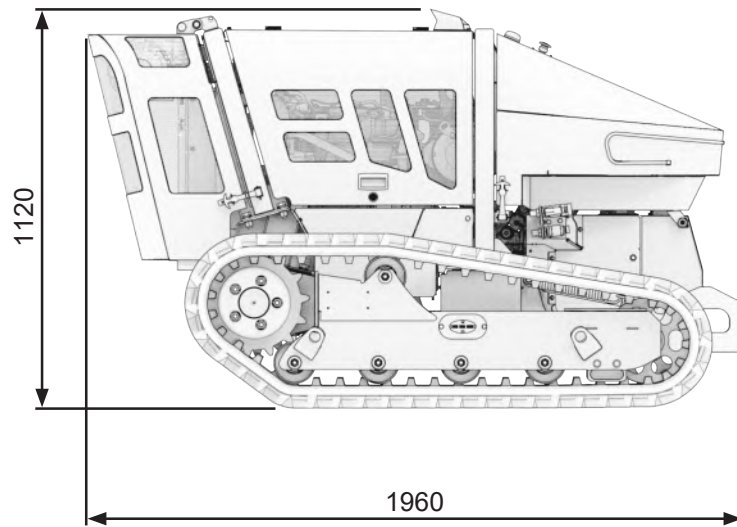
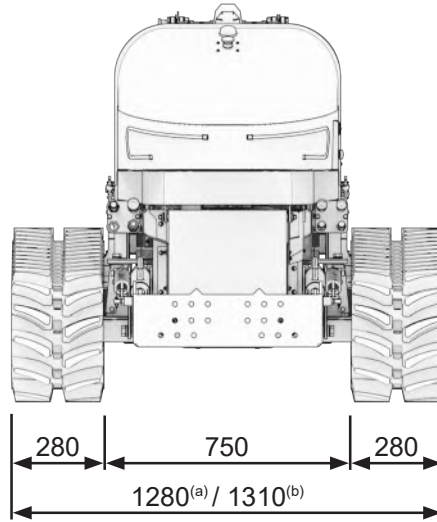

^(a) with track 250 mm;

^(b) with track 280 mm;

WEIGHT

The total weight of the RC40/T400 machine, without equipment, is **1150 kg**.

DRIVES

Supplier	YANMAR	Type	3TNV88C DYI2D
No. of cylinders	3	Engine displacement	1642 cc
Power @ 3000 rpm	29 kW / 40 CV	Peak torque @ 1950 rpm	105 Nm
Cooling	Liquid	Air filter	Dry
Exhaust gas standard	USA	EPA Final Tier 4	
	EU	Stage V	

ELECTRICAL SYSTEM

Operating voltage 12 VDC
 Alternator 55 A
 Battery 18 Ah

HYDRAULIC SYSTEM

Circuit	Pump type	Qty	Maximum capacity	
			L/min	Bar
Travel	Tandem variable displacement piston pump in closed circuit	2	28.5 each	250
Cutting head	Variable displacement pistons type in closed circuit	1	55	280
Services	Gear pump	1	12	190

TRAVEL SPEED

	Forward		Reverse	
Speed	1 (Slow)	2 (Fast)	1 (Slow)	2 (Fast)
Km/h	0 - 4	0 - 7	0 - 4	0 - 7

TRACKS

Type	Width (mm)	Weight: Pair / single track (kg)
Rubber	250 x 72 x 47	94 / 47
Rubber	280 x 72 x 47	158 / 79
Rubber with iron cleats and studs	250 x 72 x 47	200 / 100

CAPACITIES TABLE

	Quantity
Engine oil	7 L
Diesel tank capacity	21 L
Hydraulic oil tank capacity	11 L
Coolant	7 L

REMOTE CONTROL

Operating voltage	3.6 V
Capacity	2.0 Ah
Drive frequency (RF Band)	434 MHz
Signal power (RF Power)	<10 mW
MAX signal range	100 m ^(*)
Protection rating	IP65

^(*) Obviously, it is recommended that the machine be visually monitored at all times so do not operate it at a distance greater than 50 - 80 metres.

REMOTE CONTROL BATTERY

Type	Ni-MH
Voltage	3.6 V
Capacity	2.0 Ah

REMOTE CONTROL BATTERY CHARGER

Input voltage	10÷30 VDC
Output	300 / 780 mA

4.2 - MACHINE NAME

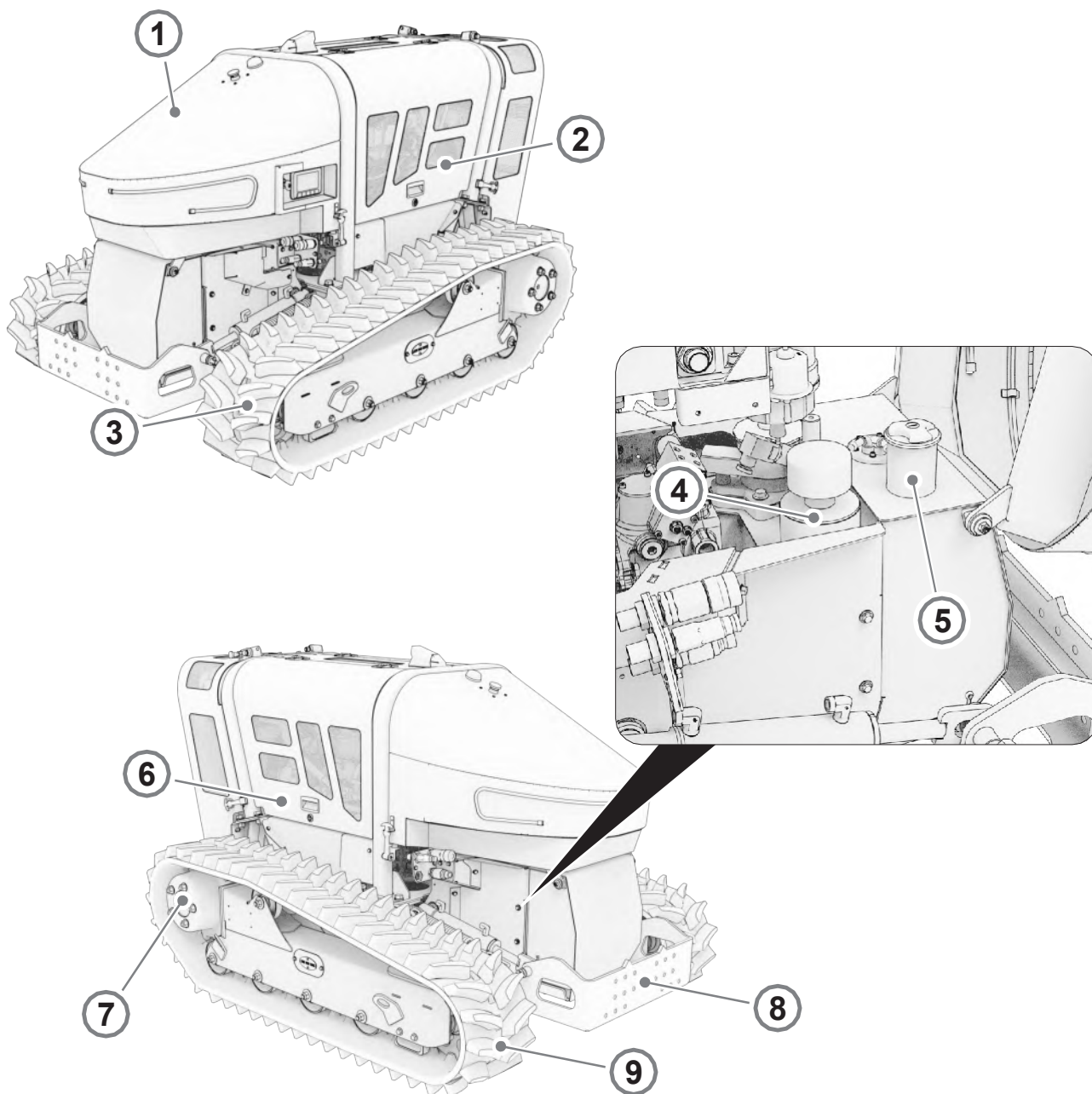

Pos.	Description
1	Front bonnet
2	Left engine bonnet
3	Left Track
4	Hydraulic oil tank
5	Fuel tank

Pos.	Description
6	Right engine bonnet
7	Right drive wheel
8	Lifting device
9	Right track

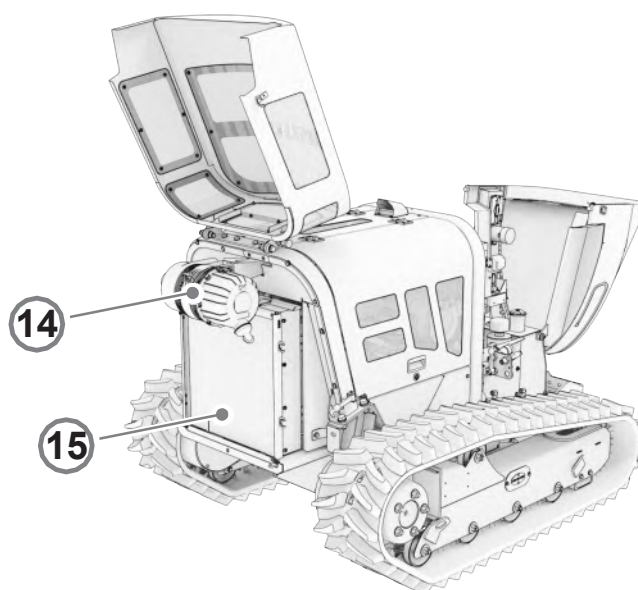
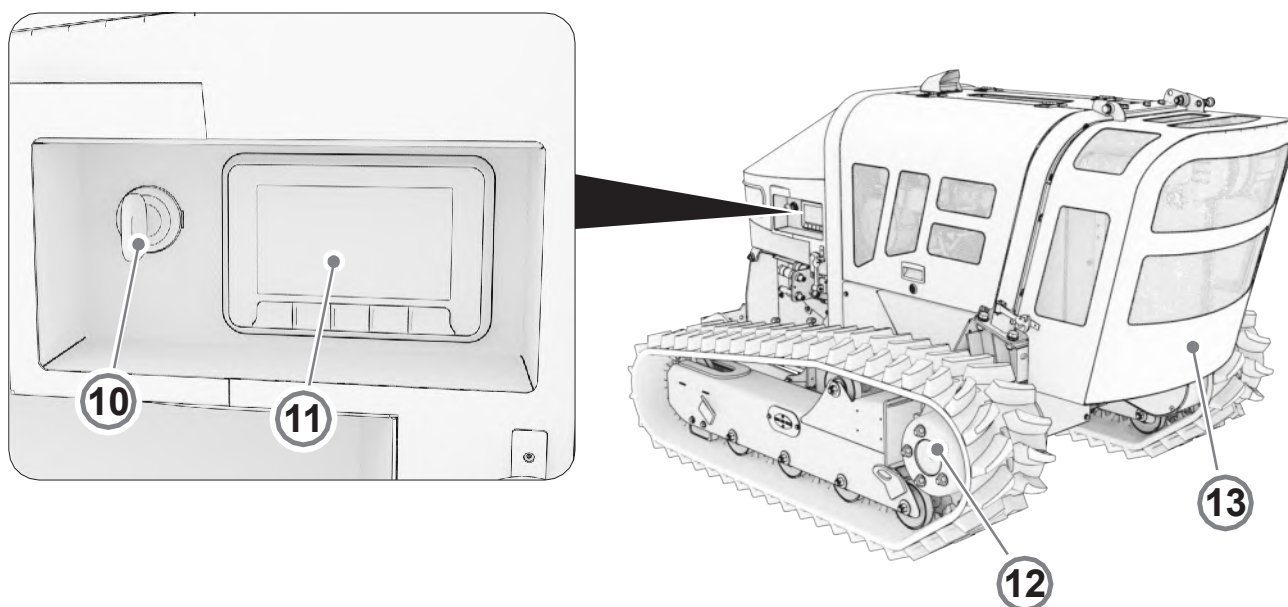

Pos.	Description
10	Ignition key
11	Display
12	Left drive wheel

Pos.	Description
13	Radiator casing
14	Air filter
15	Radiator

5 - TERMINOLOGY

5.1 - DEFINITION OF THE TERMS USED

OPERATOR

Personnel trained to operate the machine in work conditions and while travelling and trained to carry out ordinary checks and clean the machine.

Must not have disabilities of any kind or health problems.

SPECIALISED OR MAINTENANCE PERSONNEL

Personnel trained to carry out extraordinary maintenance operations, assembly, disassembly, and reassembly of machine components.

Must not have disabilities of any kind or health problems.

AUTHORISED PERSONNEL

Personnel trained to carry out extraordinary maintenance operations, assembly, disassembly, and reassembly of machine components.

Must be authorised in writing by the company McConnell to intervene on the machine.

Must not have disabilities of any kind or health problems.

OPERATOR ASSISTANT

Personnel trained to help the operator in any manoeuvre of the machine (manoeuvre at the construction site with reduced visibility, loading and unloading from the means of transport, use of the manual pump, etc.) and during the activities at the mobile construction site (cutting on public roads). Must know the main work safety requirements.

AUTHORISED WORKSHOP

Authorised repair workshop with personnel trained to carry out extraordinary maintenance operations, assembly, disassembly, and reassembly of machine components must be authorised in writing by McConnell Limited to intervene on the machine.

The operator is asked to refer to standard UNI EN 12100-2010, for the definition of the other terms in this manual.

6 - USE OF THE MACHINE

6.1 - PRELIMINARY CHECKS

The operator must verify that the machine is supplied with:

- Machine and equipment user manual;
- Check/service booklet;
- Engine manual;
- Technical annexes;

If the machine is resold as a “second hand” machine, the customer / user must provide the purchaser with the complete use and maintenance manual as well as the inspection log book.

6.2 - CHECKS TO BE PERFORMED AT THE START OF EACH WORKING DAY

- Carry out an external inspection of the machine (joints, hoses, hydraulic components, etc.) and check for any leaks of oil or other liquids.
- Check the rubber hoses of the machine and make sure there are no cuts, holes, scratches, leakages, etc.

WARNING



Never search for oil leaks with bare hands or other body parts; use paper or cloths to locate the leak. Always wear waterproof gloves and eye protection.



6.2.1 - CHECKING THE CHROME-PLATED PARTS

Carry out an inspection of the chrome-plated parts of the machine (jacks) and check that they are not scratched or damaged. In the case of damage, replace.

6.2.2 - DESCRIPTION OF RECEIVER UNIT

The radio receiver unit is located in the front where all the control units are positioned. It can only be accessed via the front bonnet.

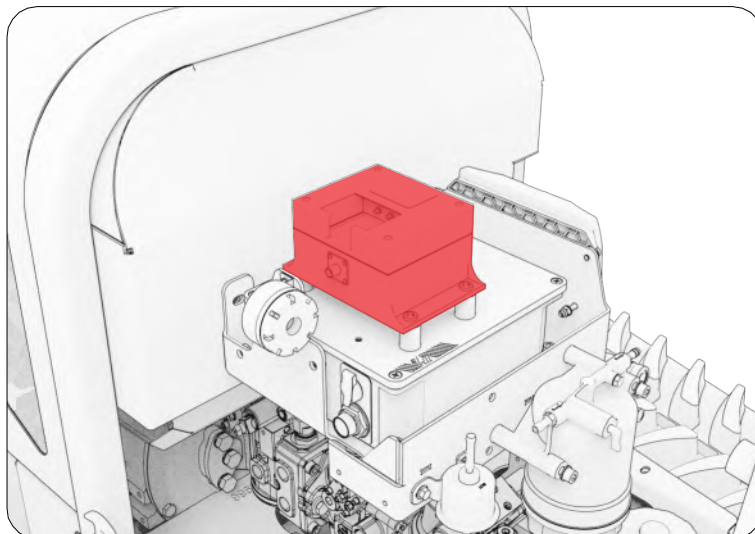
**WARNING**

If you wish to clean the machine with a pressure washer, do not direct the jet towards the radio receiver unit. Cover it with a plastic bag as a precaution.

6.2.3 - TRANSMITTER DESCRIPTION

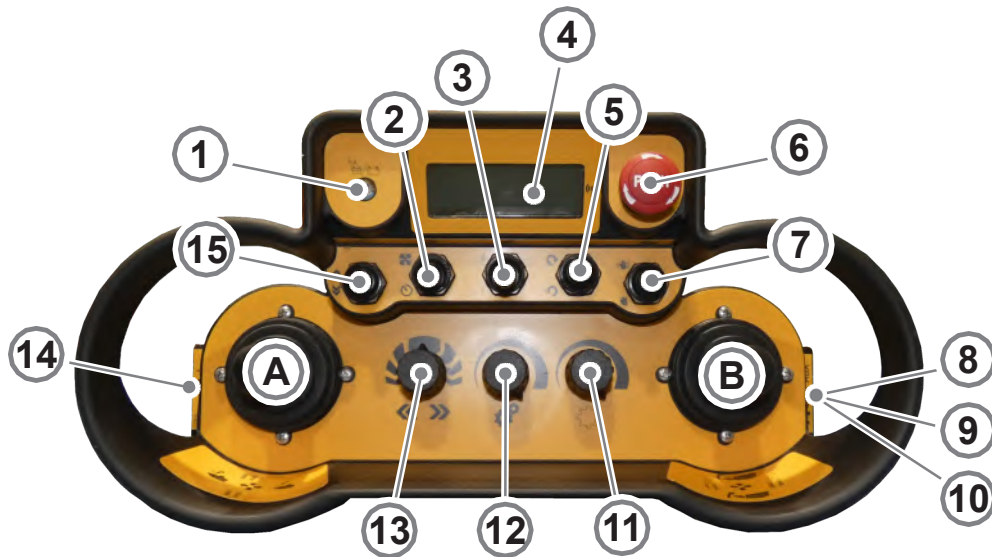

TRANSMITTER FUNCTIONS	
A	Joystick: <ul style="list-style-type: none"> • Forward/reverse gear • AUX 1 auxiliary function
B	Joystick: <ul style="list-style-type: none"> • Steering • Raise/lower tool
1	Status LED: radio/battery connection
2	Fan activation switch: manual/timed auto-pilot
3	Travel change switch: slow/fast
4	LCD Display
5	Tool motor rev/activation switch
6	Emergency button
7	Engine on/off switch
8	Transmitter/receiver connection button / horn
9	AUX 3 auxiliary function button
10	Transmitter on/off key
11	Increase/decrease potentiometer of tool hydraulic motor revs
12	Forward travel speed adjustment potentiometer
13	Steering corrector potentiometer
14	Engine revs increase/decrease buttons
15	AUX 2 auxiliary function

6.3 - TRANSMITTER USE

ATTENTION

- Before starting up the machine, the information and safety instructions contained in the user manual must be read and understood.
- Professional operators must be instructed and trained.
- Familiarise yourself with the controls before starting operation.

DANGER

- DO not take drugs or drink alcohol before or while using the machine and tools. The use of drugs and alcohol or being in a non-optimal psycho-physical condition can affect responsiveness and coordination, and therefore, impair the capability to use the equipment safely.
 - Before using the machine or equipment, the operator who usually takes medicines must consult a physician as regards the side effects of the drug that might impair the ability to use the equipment safely.
 - NEVER consciously allow anyone to use the machine when their attention or coordination is compromised.
 - This could result in serious injuries or death of the operator or third parties if the operator is under the influence of drugs or alcohol.
-

6.3.1 - CONNECTION BETWEEN MACHINE AND TRANSMITTER

To make a connection between the machine and transmitter, proceed as follows:

1. Arm the emergency stop button (A) on the machine, by turning it clockwise.
2. Turn the ignition key to the "I" position (B), by turning it one turn clockwise.
3. Arm the emergency stop button (6) on the remote control, by turning it clockwise.
4. Turn the ignition key to the "I" position (10), by turning it one turn clockwise. Wait a few seconds to allow the machine to check the active functions.
5. Press the remote control/receiver connection search button (8) to enable the connection between the transmitter and receiver.
6. When the connection occurs, an audible warning will be emitted (horn).

WARNING



- If for any reason the radio control loses the connection signal between the transmitter and receiver, the machine stops immediately and the engine revs will be reduced to idle speed.
- The connection between the transmitter and receiver must be re-established in order to continue.
- When the connection is lost, it cannot be re-connected automatically and a new connection has to be established.

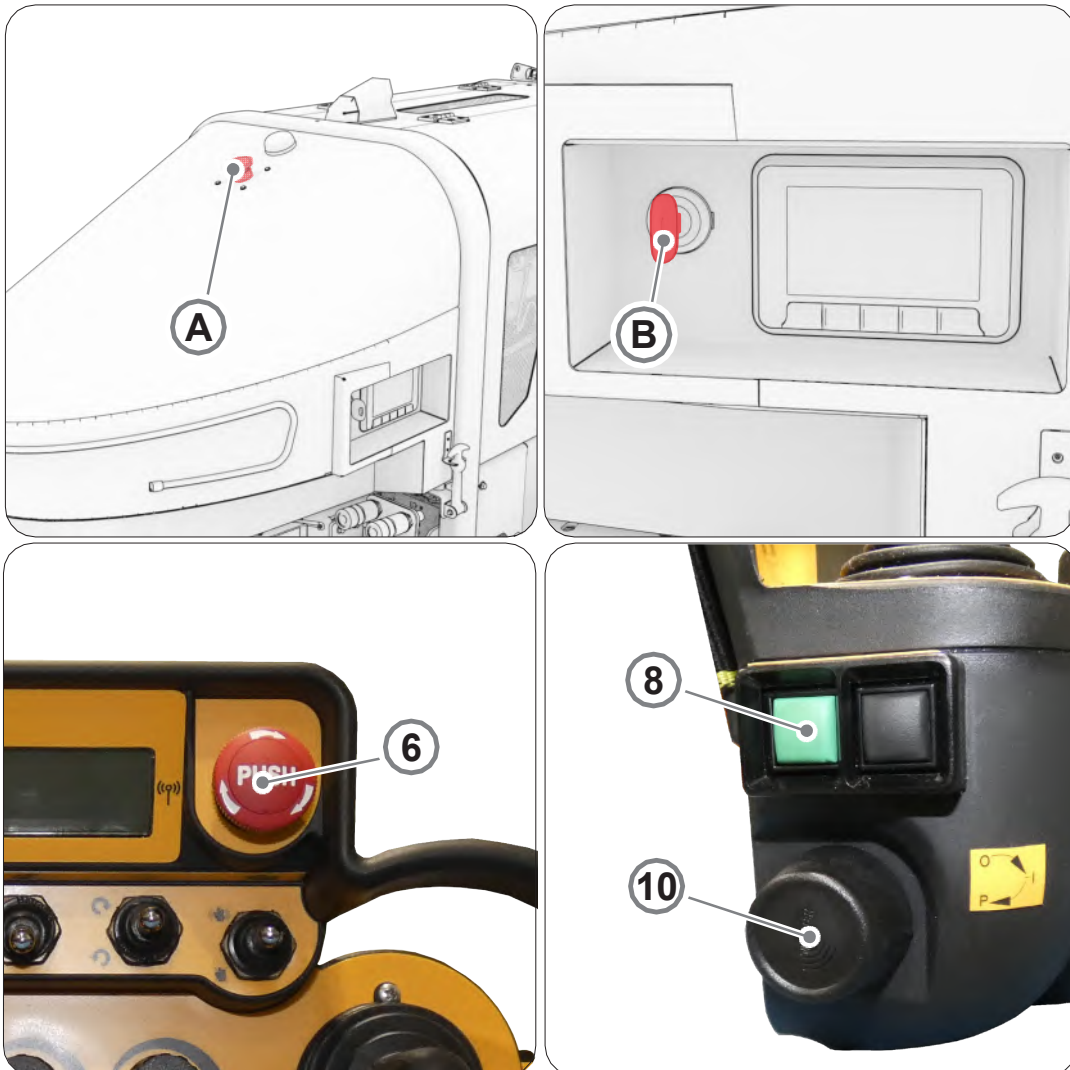

6.3.2 - STARTING THE ENGINE

ATTENTION

- **Observe the safety instructions;**
- **Only start the machine outside, not in closed environments to avoid the danger of carbon monoxide poisoning; a toxic gas which can kill in a matter of minutes. This gas is INVISIBLE, TASTELESS and ODOURLESS. Even if the exhaust fumes are not inhaled, it is still possible to be exposed to carbon monoxide. If you feel ill or weak when using the product, switch the engine off and go outside IMMEDIATELY. Contact a doctor. Carbon monoxide poisoning may have occurred.**

The machine can be started with the following means:

- Key in the machine;
- Remote control;

To start the engine using the key:

1. Turn the ignition key (**A**) to the "I" position, by turning it one turn clockwise. Wait a few seconds to allow the machine to check the active functions.
2. Turn the ignition key (**A**) to the "II" position, by turning it one turn clockwise. Release the ignition key.

WARNING

If the engine is started using the key it is no longer possible to connect with the remote control!

ATTENTION

- **The starter motor must only be operated continuously for a maximum of 30 seconds. Trying to start the engine for too long will damage the starter motor.**
- **BURNT OUT STARTER MOTORS ARE NOT COVERED BY THE WARRANTY.**

- To start the engine using the remote control, proceed as follows:
 1. Make the connection between the machine and transmitter (see section 6.3.1).
 2. Wait a few seconds for the active functions check.
 3. Press the starter switch (7) up on the remote control; once the engine has started, release the switch.

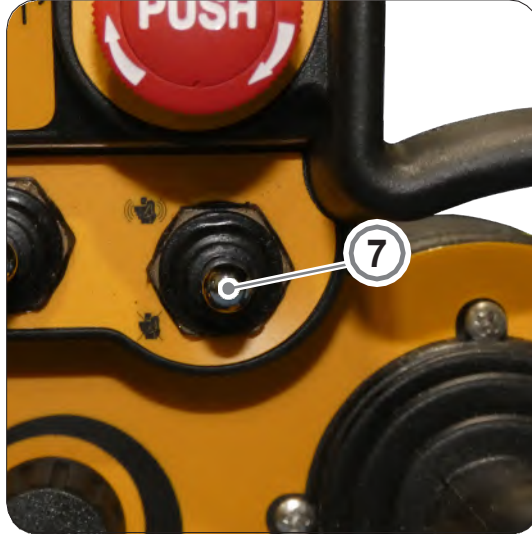
**WARNING**

- If for any reason the radio control loses the connection signal between the transmitter and receiver, the machine stops immediately, and the engine revs will be reduced to idle speed.
- The connection between the transmitter and receiver has to be re-established in order to continue.
- When the connection is lost, it cannot be re-connected automatically and a new connection has to be established.

ATTENTION

- The starter motor must only be operated continuously for a maximum of 30 seconds. Trying to start the engine for too long will damage the starter motor.
- BURNT OUT STARTER MOTORS ARE NOT COVERED BY THE WARRANTY.

6.3.3 - STOPPING THE ENGINE

To stop the engine using the remote control, proceed as follows:

1. decrease the engine rpm.
2. Wait about thirty seconds.
3. Press the switch (7) down until the engine switches off.
4. Turn the remote control off by turning the ignition key (10) anti-clockwise.
5. Press the emergency stop button (6) to disable the remote control;
6. Switch off the machine by turning the key to OFF.

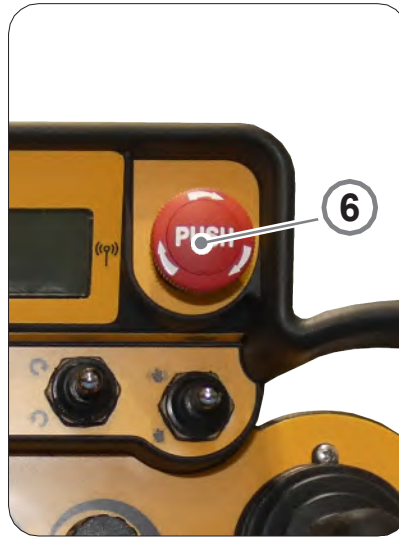

6.3.4 - STOPPING THE ENGINE IN AN EMERGENCY

An emergency stop can be carried out as follows:

- **Press the emergency stop button on the machine (A):** in this case, all the operations will shut down and the engine will switch off.
- **Press the emergency stop button on the remote control (6):**
 1. In case of an emergency, press the emergency button (6) on the remote control;
 2. The engine will continue to run at idle speed and all operational functions will be cancelled;
 3. Switch off the machine by turning the key (B) to OFF.



To start up again, you must:

4. Check that the cause of the emergency stop has been eliminated.
5. In the event of an emergency stop, the reset procedure has to be carried out and the operating functions reactivated.

WARNING



- **Always remember to turn the ignition key to “0” after switching off the engine. If the key remains in the “I” position, the electric diesel pump may overheat and draw in air causing it to break down. Additionally, if it is left like this for a long time, it uses a large amount of power and damages the battery.**
- **McCONNEL RESERVES THE RIGHT TO REPLACE THE DAMAGED PART ONLY AFTER ANALYSING IT.**

6.3.5 - ENGINE RPM CHECK

The buttons (14) on the left-hand side of the remote control are used to increase (A) and decrease (B) the engine revs.

Press the buttons repeatedly or hold them down (A) (B) to adjust the revs.



6.3.6 - SLOW/FAST TRAVEL SWITCH

Press the switch (3) up to engage fast gear or down to engage slow gear.



6.3.7 - TRAVEL SPEED POTENTIOMETER

The potentiometer (12) regulates the maximum speed of the machine from 0 to 100%. The potentiometer setting chosen will depend on the various work conditions that the operator will come across and should always ensure maximum control over the machine.



6.3.8 - MOVING THE MACHINE FORWARDS AND BACKWARDS

The forward travel of the machine is controlled by the left-hand proportional joystick (A).

- The machine moves forwards by shifting the joystick (A1) forwards.
- It reverses when the joystick (A2) is shifted backwards.
- It is a proportional control so the more you move the joystick the faster the machine moves.
- The top speed that can be achieved will be determined by the potentiometer position (12) and the speed selected (3).



6.3.9 - STEERING THE MACHINE

The steering is controlled by the right-hand proportional joystick (**B**).

- The machine steers to the left when you move the joystick (**B3**) to the left.
- The machine steers to the right when you move the joystick (**B4**) to the right.

The right-hand joystick (**B**) used in combination with the left-hand joystick (**A**) allows the machine to be turned 180°, thus turning the machine in the opposite direction.



6.3.10 - STEERING BIAS CONTROL

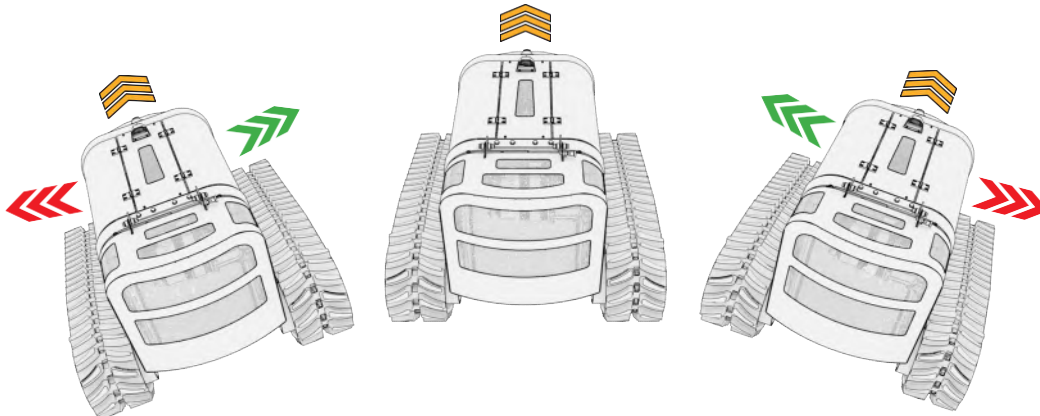

If when working on steep slopes, you notice that the machine is steering downhill, you can correct the trajectory using the potentiometer (**13**).

Turn the potentiometer either clockwise or anti-clockwise to correct the machine's trajectory. For example, if the machine tends to steer to the left, downhill: correct the trajectory by turning the potentiometer anti-clockwise until the machine starts to travel in a straight line.



6.3.11 - LIFTING DEVICE

The lifting device is controlled by the right-hand proportional joystick (B).

- The lifting device is lowered by moving the right-hand proportional joystick (B) forwards.
- The lifting device is raised by moving the joystick (B2) backwards.



WARNING



FLOATING FUNCTION

Lower the lifting device so that the tool is resting on the ground. Extend the cylinder rod of the lifting device until the pin reaches the centre of the slot. In this way, the tool will follow the contour of the ground more accurately.

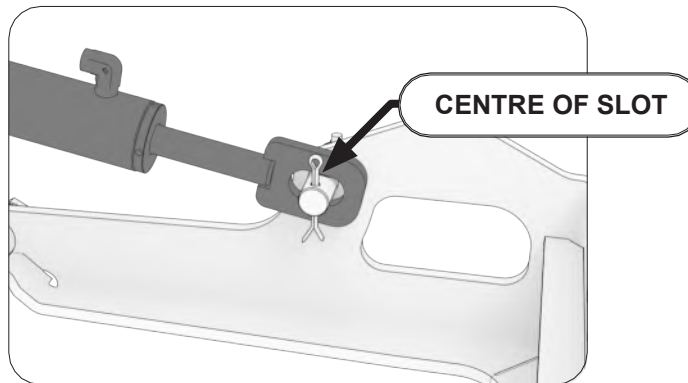

ATTENTION



- It is recommended not to adjust the lifting device when the equipment is in operation to prevent cutting residues from being thrown long distances.
- It is recommended not to adjust the lifting device if you are on a slope with the front of the machine facing uphill.

6.3.12 - HOW TO HITCH UP A TOOL

DANGER



- When coupling or uncoupling equipment, stand at the side of the machine away from the equipment (at least one metre away).
- Before connecting the quick fit attachments, the equipment must be connected to the machine mechanically.
- The hydraulic connections must be carried out when the engine is switched off.

ATTENTION



- Before making a hydraulic connection between machine and equipment, clean the quick couplings of both parts with a cloth; this prevents the hydraulic oil becoming contaminated with foreign matter.
- Firmly tighten the screw-on hydraulic couplings after hitching the equipment.
- Failure to tighten the quick couplings (even partially) can cause the hydraulic motor of the tool to break and / or the oil seal to be ejected.

ATTENTION



- Read and follow the instructions provided to ensure safety during the use of the equipment moved by the PTO.
- Comply with the indications provided by the equipment manufacturer.
- Use the safety devices prescribed and make sure that they are in good condition.
- Make sure that the equipment is correctly connected and that it does not hit other parts of the machine when raised.

ATTENTION



In some cases, the tool change causes the overall centre of gravity to shift which could make the machine unstable. Contact McConel about adding ballast to correct the machine's centre of gravity.

The machine is fitted with a lifting device on which the various approved tools can be attached.

To do this, follow the steps below:

1. Start the diesel engine and connect with the remote control (see section 6.3.1);
2. Lower the lifting device as far as possible using the right-hand joystick (B);

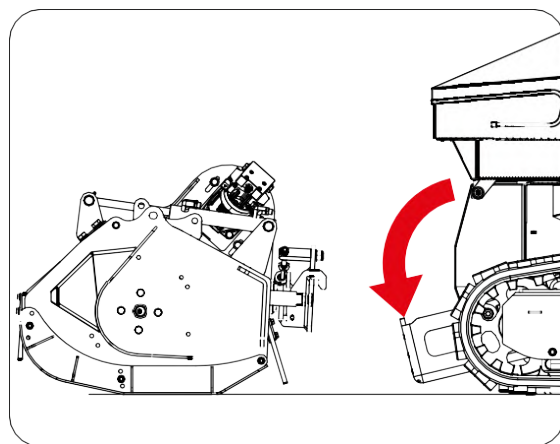

3. Slowly move the RC40/T400 until it is close to the mounting plate of the tool that was previously placed in front of the machine;

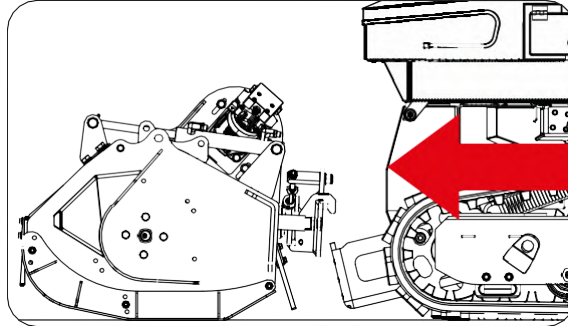

4. Using the right-hand joystick (B), raise the lifting device to attach the equipment;
5. Secure the tool with six M12 x 40 bolts to the machine support using an 18-mm spanner;
6. Turn off the engine;

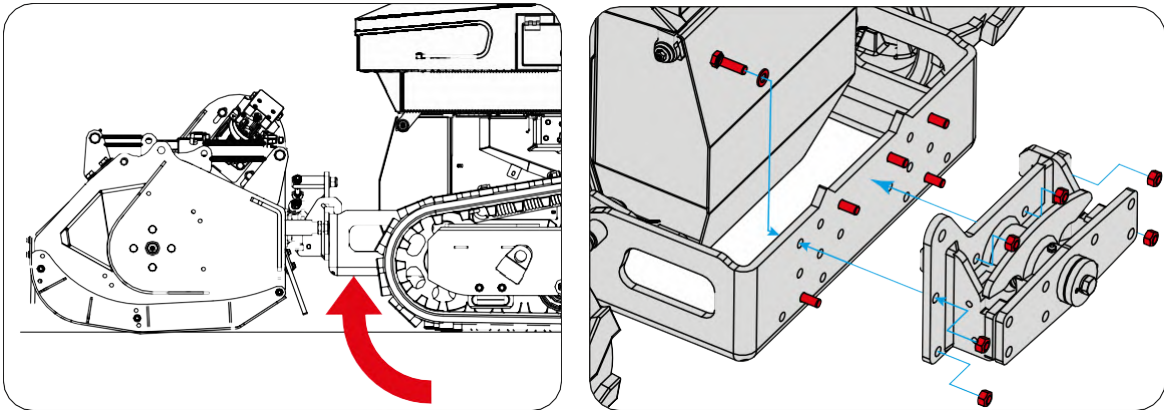

7. Connect the hydraulic power lines of the tool to the quick couplings on the right-hand side of the machine; taking care to clean them before making the connection. The outermost coupling is for the drainage line, while the inner two are for lines (A) and (B).

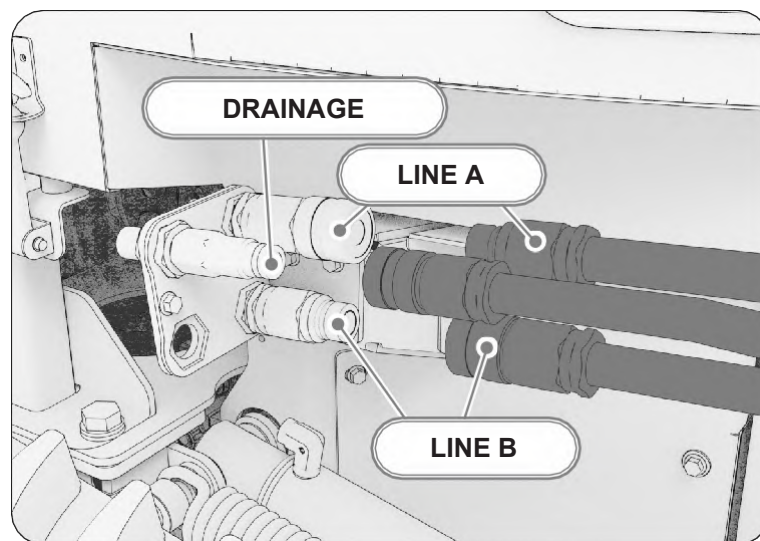

8. Connect the hydraulic service pipes (of the tool) to the machine's quick couplings on the right-hand side, taking care to clean them before making the connection.
 - The outermost couplings are used for the auxiliary function (AUX 1).
 - The innermost couplings are used for the auxiliary function (AUX2).

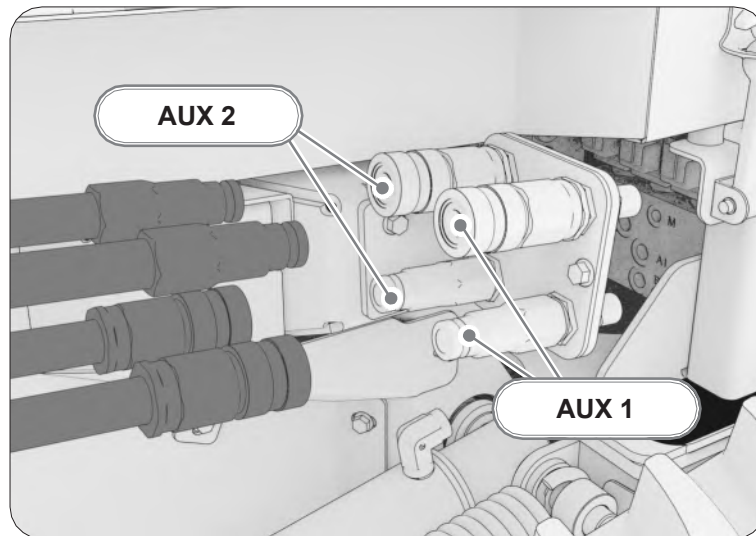

6.3.13 - OPERATING THE TOOL

The tool's hydraulic motor is enabled by the switch (5) and controlled by the potentiometer (11). Follow the instructions below to start it.

- Then, enable and select the rotation of the tool's hydraulic motor using the switch (5). To move the tool, gradually turn the potentiometer (11) clockwise. When the tool starts to move, increase the hydraulic engine rpm by turning the potentiometer to 100%.
- Now, you can increase the rpm of the engine until you reach the desired working speed by pressing the button (14A).



6.3.14 - STOPPING THE TOOL

To stop the tool, proceed as follows:

- Decrease the engine rpm by pressing the button (14B) until you reach the minimum speed.
- Turn the potentiometer anti-clockwise (11) to the minimum setting. The tool's hydraulic motor then stops.
- Disable the hydraulic motor by putting the switch (5) in the central position.



6.3.15 - AUXILIARY FUNCTION (AUX 1)

The auxiliary function (AUX 1) is controlled by the left-hand proportional joystick (A).

- The auxiliary function is operated by moving the joystick (A4) to the right.
- The opposite effect of the auxiliary function is obtained by moving the joystick (A3) to the left.

NOTE: Refer to the use and maintenance manual of the tool connected to the machine for how to use this function.

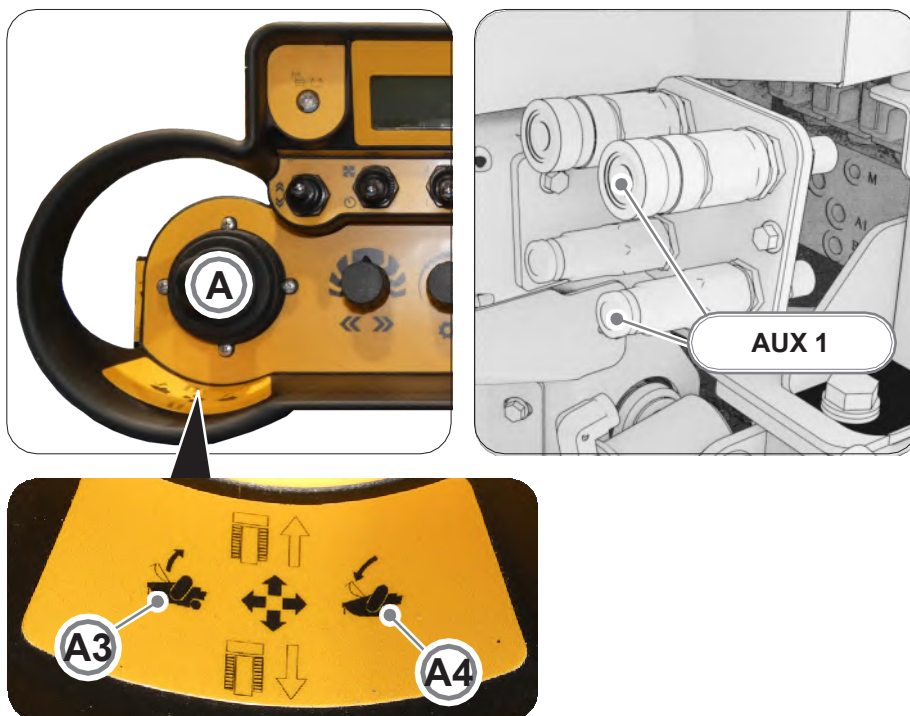

6.3.16 - AUXILIARY FUNCTION (AUX 2)

The auxiliary function (AUX 2) is controlled by the switch (15).

- The auxiliary function is enabled by pressing the switch up.
- The auxiliary function with the opposite effect is enabled by pressing the switch down.
- The central switch position is neutral.

NOTE: Refer to the use and maintenance manual of the tool connected to the machine for how to use this function.



6.3.17 - AUXILIARY FUNCTION (AUX 3)

The auxiliary function (AUX 3) is controlled by the button (9).

- The auxiliary function is enabled by pressing the button.

NOTE: Refer to the use and maintenance manual of the tool connected to the machine for how to use this function.



6.3.18 - TRANSMITTER/RECEIVER CONNECTION BUTTON / HORN

This button has two functions:

- The first function is used when the machine is switched off to connect the transmitter to the receiver.
- The second function is only used when the machine is switched on and allows the button to be used as a horn.



6.3.19 - REVERSIBLE FAN

The reversible fan is controlled by the button (9).

- The fan blades are inverted when the switch is pressed up. The blades remain inverted until the switch is released.
- If the switch is pressed down, the fan blades are automatically inverted for a set time.
- The central switch position is neutral.

**WARNING**

Before inverting the fan blades:

1. **Decrease the engine rpm to minimum.**
2. **Run the inversion command.**
3. **Gradually increase the rpm of the engine.**

ATTENTION

- **Before reversing the direction of the fan blades, make sure that there are no people or animals close to the machine or in the direction of the radiator to prevent them being covered with dust.**
- **Maintain a distance of at least 10 meters from the machine and wear the recommended PPE.**



6.3.20 - REMOTE CONTROL DISPLAY

The remote control has an LCD display on which some parameters can be viewed which indicate the machine status during operation.

The parameters displayed are:

rpm of the engine	RPM
Coolant temperature	°C
Fuel tank level	%



6.3.21 - STATUS LED

The status LED indicates the charge and battery status.

- When it flashes and alternates from green to red, it indicates that the battery has run out.

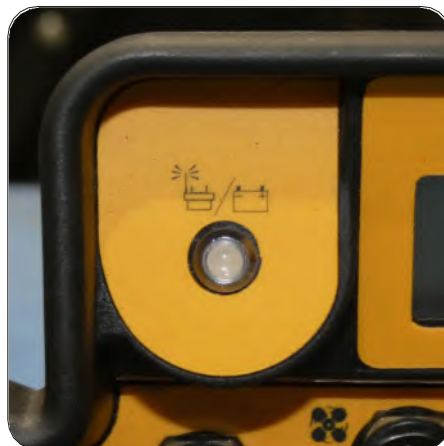

6.4 - CONTROL PANEL

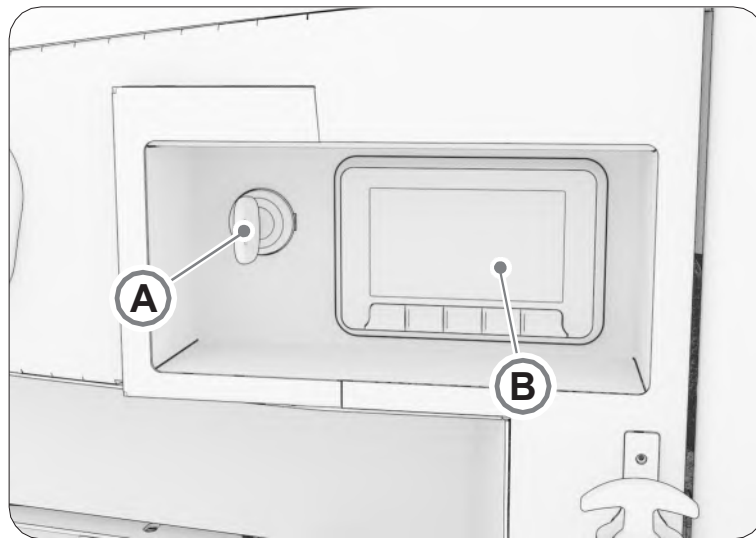

6.4.1 - LCD DISPLAY

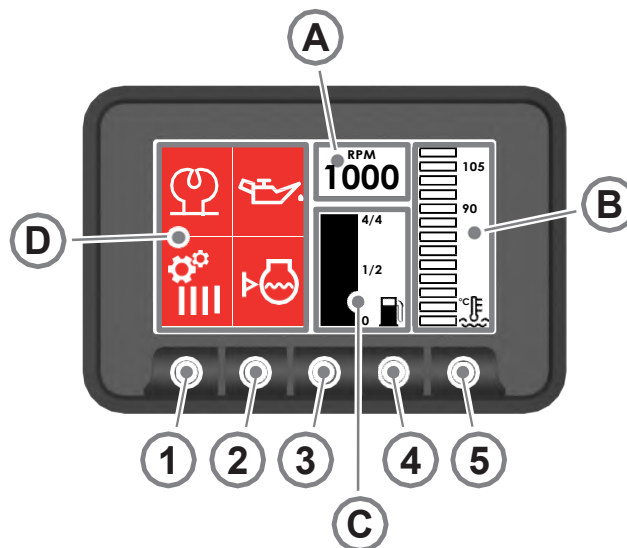

A	Engine rpm
B	Coolant temperature
C	Fuel liquid level
D	Warning light/fault area
1	PAGE UP button
2	PAGE DOWN button
3	ENTER button
4	HOME button
5	---

HOW TO MOVE AROUND IN THE MENU

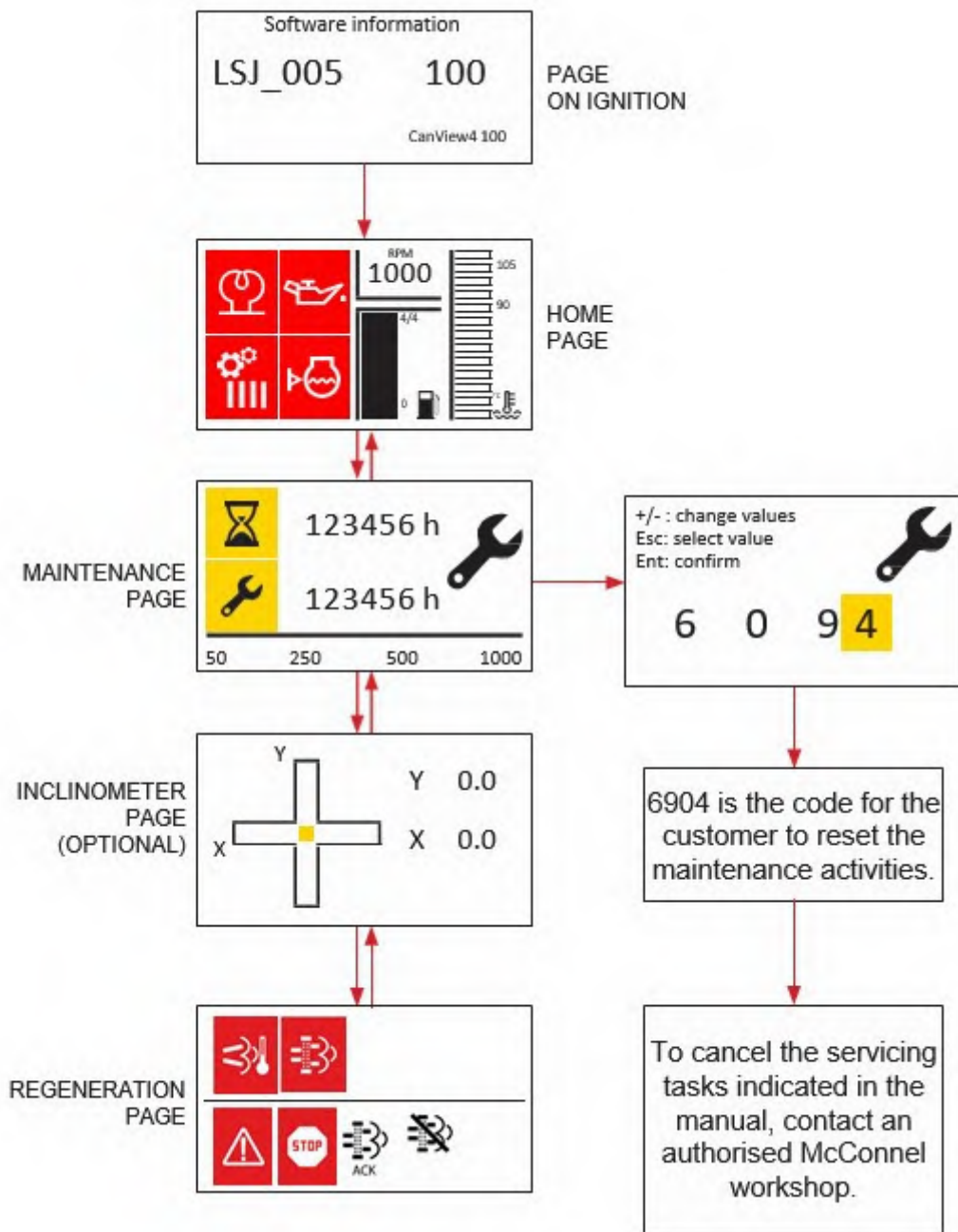

6.4.2 - WARNING LIGHTS

The following indicator lights/warnings may appear on the display according to the faults that may arise.

	HORN	STOPS ENGINE	CAUSE	SOLUTION
	YES	NO	Fuel tank less than 1/4 full	Top up
	NO	NO	The parking brake is on	Move the left-hand side joystick forwards/backwards
	YES	NO	Hydraulic oil level less than 2/3	Top up and/or check for leaks
	NO	YES	Oil level too low	Top up and/or check for leaks
	NO	NO	The alternator does not charge the battery	Check the alternator and/or contact customer care
	NO	YES	The air filter is clogged	Clean the filter elements
	NO	YES	The hydraulic oil filter is clogged	Replace the cartridge
	NO	NO	Glow plug preheating is active (optional)	Wait for the indicator light to turn off and start the machine
	NO	YES	Engine oil pressure too low	Check the engine oil level and/or the engine oil sensor
	NO	YES	Engine stop	Release the emergency button
	NO	YES	Coolant temperature > 110°C	Clean the radiator and/or check the level of coolant
	NO	NO	Low coolant level	Top up
	NO	NO	Change mode	---

6.4.3 - MACHINE HOURS COUNTER / MAINTENANCE SCREEN

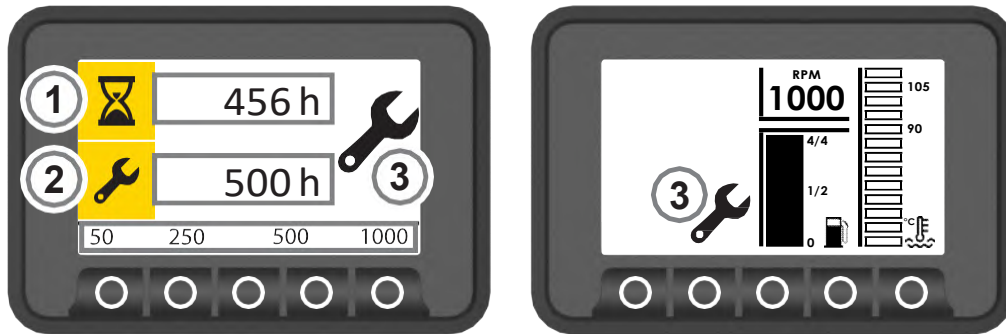

- The display shows the machine hours (1) and the scheduled servicing times (2).
- See the Maintenance section when the scheduled number of hours has been reached.
- The servicing indicator light (3) appears when the scheduled maintenance times have been reached. Press the PAGE UP or DOWN key to view the counter and scheduled servicing.
- For servicing, indicated in the specific manual, contact your local authorised service centre.

ATTENTION



The Service indicator light will flash every time the engine is started until the release code is entered (once the machine has been serviced).

MAINTENANCE CODE

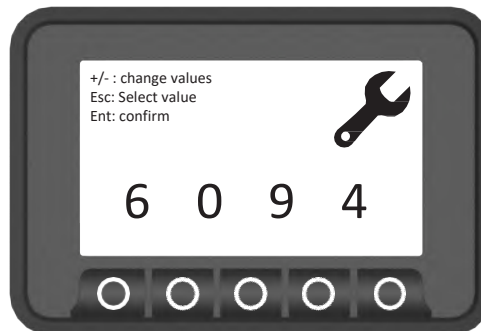

Every 50 hours, the machine prompts you to inspect it, after which the maintenance error has to be reset.

1. When the servicing has been completed, enter the four-digit numeric code (four digits) supplied at the time of purchase or contract McConnell's support service. The code in this case is 6094.
2. To view the page, press the ENTER button for 3 seconds.
3. Enter the code by moving from left to right with the HOME key.
4. Confirm the operation by pressing the ENTER key.

ATTENTION



Entering the code without having carried out the required service will invalidate the McConnell warranty.

6.4.4 - ALARMS SCREEN

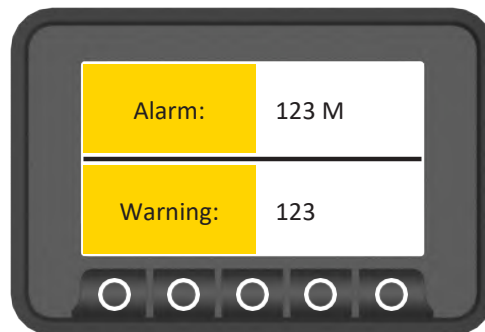

If the machine breaks down and/or malfunctions, "Alarm" codes will appear on the display followed by a number that identifies the type of error.

ATTENTION

Contact McConnel's support service for further information.

6.4.5 - INCLINOMETER SCREEN (OPTIONAL)

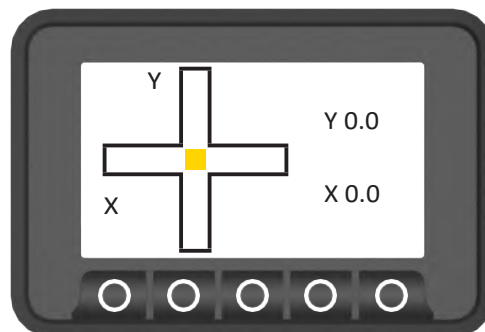

As an option, it is possible to have an inclinometer menu screen.

6.4.6 - CHANGE OPERATION MODE SCREEN (OPTIONAL)

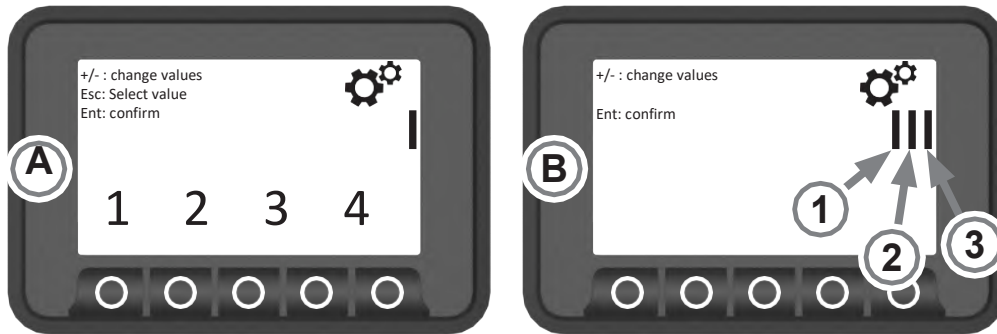

There is also an option to set three different modes of operation for the RC40/T400 according to the type of work to be carried out.

It is possible to access the menu in the following way:

- Scrolling in the menu with the UP and DOWN arrows to the screen (A);
- Enter the numeric code (**1234**) supplied at the time of purchase or contact McConnell's support service, then press ENTER;
- This accesses the screen (B) in which it will be possible to select modes (1), (2) or (3) using the UP and DOWN buttons; press ENTER to confirm the mode required.

6.4.7 - REGENERATION SCREEN

All the buttons and indicators that are seen and used for the DPF cleaning process, which is either started automatically, or by the operator, and for disabling it are described below.

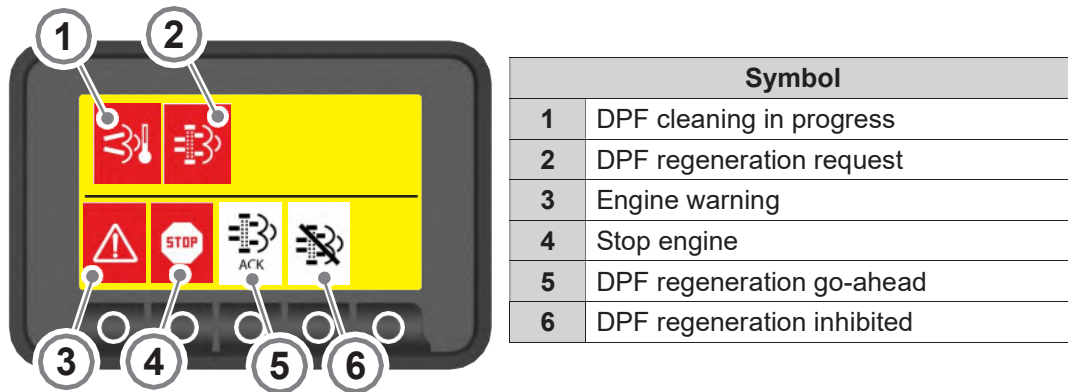

NOTE: The diagnostics screen is never seen with all the lights on at the same time, as shown. The figure serves only as an illustration of indicators that might be seen during operation.

- 1. DPF CLEANING IN PROGRESS:**

 - Appears during stationary regeneration;
 - Disappears when regeneration has finished;
- 2. DPF REGENERATION REQUEST:**

 - Appears when the ECU (diesel engine control unit) determines that stationary regeneration is required. Press the start stationary regeneration request button.
 - The indicator disappears when stationary regeneration starts;

3. **ENGINE WARNING:**
 - Appears when errors in the diesel engine are detected. Contact McConnell's support service;
 - Flashes when stationary regeneration is required;
 - Flashes when the DPF (level 1) has to be cleaned of ash. Contact McConnell's support service;
4. **STOP ENGINE:**
 - Appears when serious engine faults are detected. Stop the engine immediately and contact McConnell's support service;
 - Flashes when the DPF (level 2) has to be cleaned of ash. Contact McConnell's support service;
5. **DPF REGENERATION CONSENT:**
 - Flashes during stand-by before regeneration and remains on when the stationary regeneration starts.
 - The indicator disappears when the regeneration ends;
6. **DPF REGENERATION INHIBITED:**
 - Appears when the inhibit regeneration button is pressed.

6.4.8 - FUSES AND RELAYS

ATTENTION



Before replacing a fuse, make sure that you have removed the ignition key. If the fuses are oxidised, corroded or are not perfectly retained in place, only replace with fuses of the same capacity. If the engine does not turn when the starter switch is moved to the ignition position, check the main fuse and replace it if necessary.

6.4.9 - FUSES AND RELAYS OF THE CENTRAL CONTROL UNIT

The fuses and the relays are situated in fuse box (A) on the right-hand side of the machine in the rear engine compartment; remove the lid and change the fuses and relays if necessary.

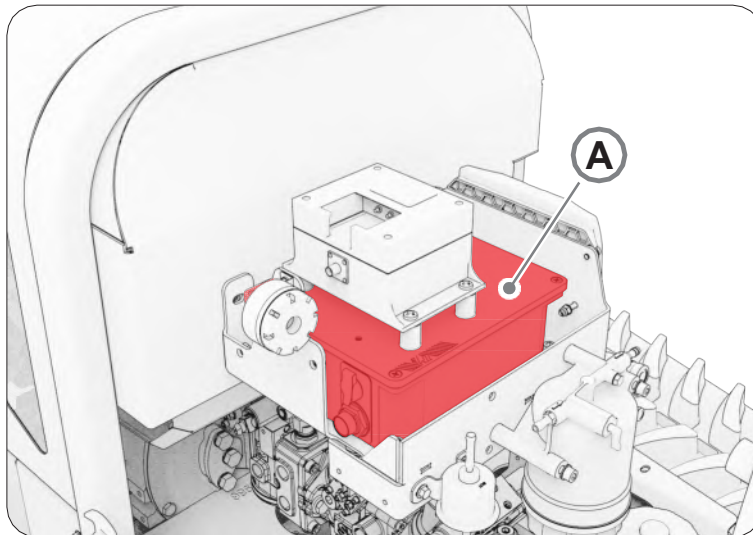

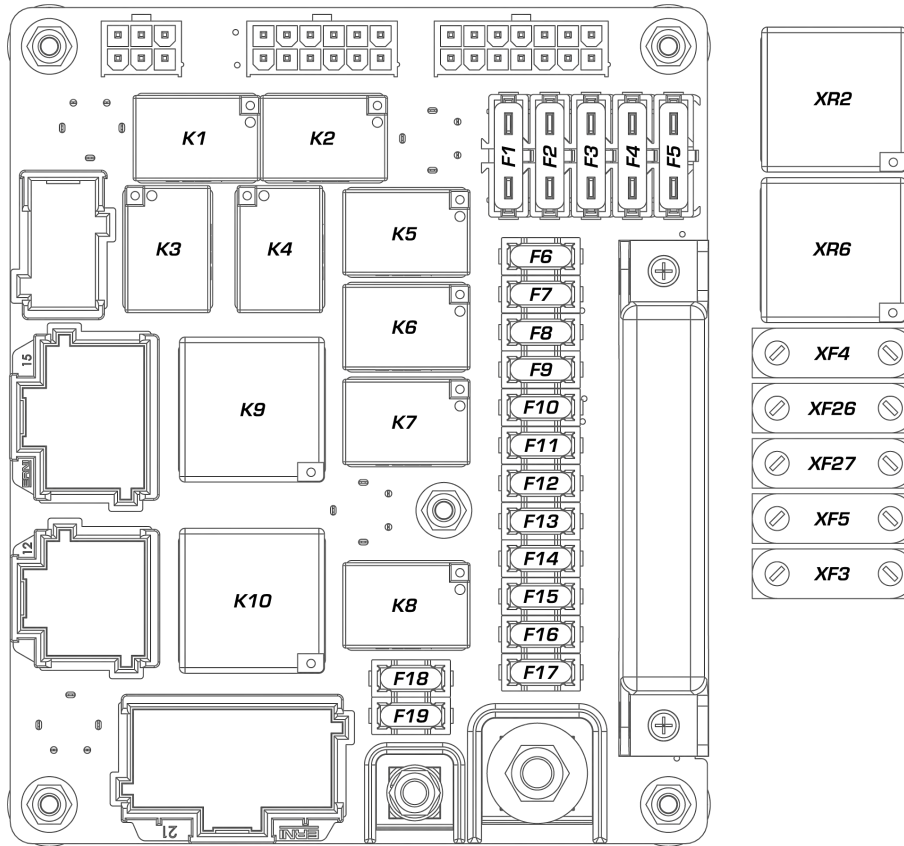

FUSES

Position	Amp	Function
F1	10	Radio control
F2	-	-
F3	15	Engine control unit
F4	-	-
F5	20	Work lights
F6	-	-
F7	10	Horn
F8	-	-
F9	-	-
F10	-	-
F11	10	Telematics
F12	-	-

Position	Amp	Function
F13	10	12V socket
F14	7.5	Ignition panel
F15	5	Alternator
F16	7.5	Automatic idler roller
F17	10	LE70
F18	7.5	Fuel pump
F19	7.5	Sensors
XF3	40	Services
XF4	20	LE70
XF5	70	Start-up
XF26	20	ECU
XF27	20	EGR

RELAYS

Position	Function
K1	-
K2	-
K3	Low engine oil pressure
K4	Start controller
K5	Radio / manual control
K6	Horn

Position	Function
K7	-
K8	Interlock
K9	Work lights
K10	EGR
XR2	Power supply
XR6	Start-up

GLOW PLUG FUSE

Position	Amp	Function
F20	40	Glow plugs pre-heating

GLOW PLUG RELAY

Position	Function
K11	Glow plugs pre-heating

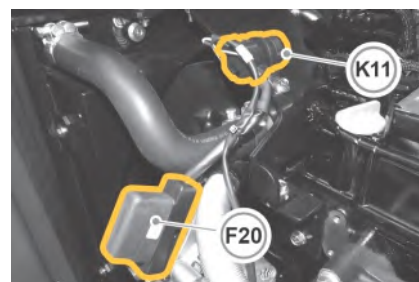

6.5 - EXHAUST GAS POST TREATMENT SYSTEM

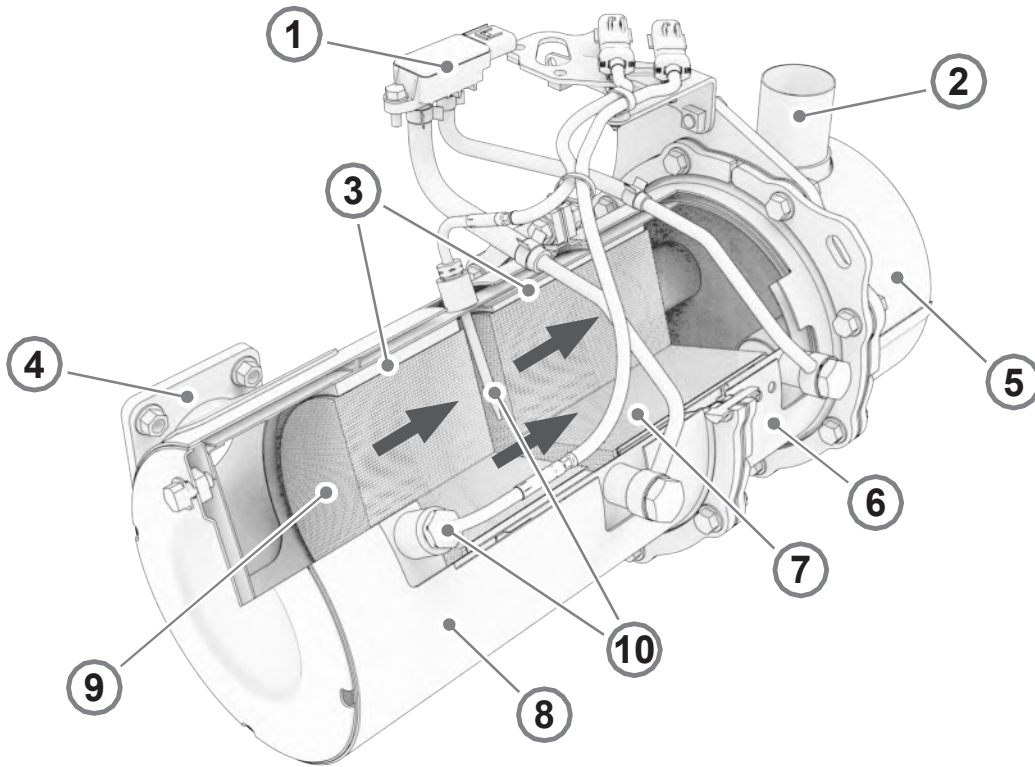

- | | |
|--------------------------------|------------------------------------|
| 1 Differential pressure sensor | 2 Exhaust gas outlet |
| 3 Installation material | 4 Exhaust gas inlet |
| 5 Muffler | 6 SF filter container |
| 7 SF filter | 8 DOC container |
| 9 DOC | 10 Exhaust gas temperature sensors |

6.5.1 - DPF OVERVIEW (PARTICULATE FILTER)

The DPF consists of a Diesel Oxidation Catalyst (DOC) and an SF (Soot Filter). The purpose of the DPF is to prevent particulates, which are harmful to both man and the environment, from being released into the air. This is achieved by the DOC that breaks down the dangerous molecules and the SF that collects the particulates. If the level of particulates that have accumulated in the SF is high, it will clog and reduce the performance of the engine. A means to regenerate the SF is therefore required. The engines used by McConnel use a continuous regeneration method i.e. they regenerate the filter at the same time as they collect the particulates. In order to increase the regeneration performance, the particulates collected in the SF are burnt with the NO₂ generated in the DOC and with the O₂ in the exhaust gases. At the same time, the DOC purifies the exhaust gases by converting, for example, acetylene (HC) and carbon monoxide (CO) into water (H₂O) and carbon dioxide (CO₂) respectively.

6.5.2 - MAINTENANCE AND ASSISTANCE FOR THE PARTICULATE FILTER

In addition to particulates, ash also accumulates in the SF. This is mainly due to metal additives contained in lubricating oil. A small quantity of lubricating oil is burned in the combustion chamber, which is then collected in the SF together with the combustion gases. This small amount of metallic ash cannot be burned in the DPF. It therefore builds up over time and causes the engine to lose pressure, as well as having other negative effects on it. In this case, the DPF has to be cleaned. McConnel recommends performing maintenance every 6000 working hours.

Make sure that you use specific fuel and lubricating oil so that the DPF can function correctly. Use a type of diesel that has a very low sulphur content ≤ 15 ppm. If you use a fuel other than the one specified, it might prevent the DPF from being regenerated properly by generating an excessive quantity of particulates. This results in an excessive fuel consumption and the deterioration of the engine (reduced performance) due to the continuous activation of the regeneration process.

It is also recommended to use a lubricating oil with a low carbon content, otherwise an excessive amount of ash will build-up in the DPF in a short time. This results in an excessive fuel consumption and the deterioration of the engine (reduced performance) due to the continuous activation of the regeneration process. It will also mean that maintenance of the SF will have to be carried out earlier.

The owner of the RC40/T400 is responsible for carrying out the maintenance described in the service booklet. The exhaust filter warning indicator on the display or the diagnostic codes indicate when the ash needs to be removed from the particulate filter.

The removal of the ashes from the particulate filter must be carried out by specialised personnel and in complete safety. Do not remove the ashes using water or other chemical substances. If these methods are used to remove the ash, there is a risk of damaging the material that secures the particulate filter inside the casing. This may loosen the cartridge inside the casing and make the particulate filter more susceptible to damage due to vibration.

The failure to respect the methods approved for the removal of the ashes could cause damage to the DPF filter producing the potential annulment of the guarantee on the exhaust filter emissions for diesel engines. Contact McConnel customer care for any servicing information that may be required.

ATTENTION



- **The removal of ashes from the DPF filter must be done exclusively by a qualified assistance provider.**
- **During the manipulation and cleaning of a DPF filter it is necessary to wear personal protection equipment and protective clothing kept in hygienic and reliable conditions.**
- **For advice, contact McConnel's support service or a qualified service supplier.**

ATTENTION

The exhaust filter must be handled correctly when it reaches the end of its useful life, as ash or catalyst substances in the device may be classified as hazardous waste under local laws or regulations. Exhaust filter replacements, including the particulate filter, can be ordered from McConnel.

6.5.3 - RESET REGENERATION

Reset regeneration is carried out automatically by the RC40/T400 every 100 hours. This regeneration lasts for 30 minutes, during which:

- the regeneration light comes on.
- the customer can safely continue to work.
- the machine does not produce an alarm code.

In the event that the machine fails to perform reset regeneration because, for example, the machine has been switched off during this operation, the RC40/T400 will request a stationary regeneration (see paragraph 6.5.4).

6.5.4 - STATIONARY REGENERATION

The EAT system (exhaust) constantly checks for fume obstruction inside the DPF. Even if the DPF checks the regeneration frequently and the machine does not work at full load, it cannot be regenerated. This means that if the motor is not used with loads which have power absorptions greater than 60%, the control unit will not easily allow the regeneration operations.

The electronic control unit determines when stationary regeneration has to be carried out. The DPF regeneration request symbol appears on the display (see section 6.4.7) and warns the operator via an acoustic signal.

Stationary regeneration is only requested when 50 hours have passed since the last complete regeneration; regardless of the type of regeneration carried out, whether reset or stationary.

- **If the DPF regeneration request symbol appears, carry out stationary regeneration immediately.**
- **If the DPF regeneration request indicator is ignored (see section 6.4.7), an excessive quantity of particulates accumulate in the DPF, causing them to burn, which could result in a fire and damage to the DPF.**

ATTENTION



Follow these rules when carrying out stationary regeneration:

- Do not carry out the regeneration in enclosed places; the accumulation of gases can cause carbon monoxide poisoning;
- Regeneration involves bringing the exhaust gases to a high temperature so make sure that there are no flammable materials around the machine;
- Regeneration involves bringing the exhaust gases to a high temperature:
 1. Do not touch the end of the exhaust pipe;
 2. Do not stand close to the exhaust pipe;
- Make sure there is enough fuel before starting the exhaust gas filter cleaning process.

If it is not possible to move the machine to a safe position, the operator must temporarily deactivate the automatic exhaust gas filter cleaning function.

Press the "HOME" button on the machine's display.

Once the machine is in a safe position, use the forced regeneration function (see section 6.5.5).

6.5.5 - FORCED STATIONARY REGENERATION

Forced stationary regeneration is a process that takes place when requested by the operator. This process allows the system to clean the DPF if the operator has previously had to stop the cleaning of the above-mentioned filter because of particular conditions. During this process the engine speed is controlled by the ECU and the machine must be parked for the procedure to be completed. The time necessary to carry out the forced cleaning of the DPF depends on how badly the filter in question is clogged, on the ambient temperatures and on the temperature of the exhaust gases.

The overall duration of the cleaning varies on the basis of various criteria such as the type of fuel and oil, the service cycle and the number of requests for the cleaning of the exhaust gas filter broken off previously.

To carry out forced stationary regeneration proceed as follows:

1. Make sure that you have accessed the RC40/T400 via the remote control;
2. Heat the RC40/T400 to a temperature over 60°C as in *Figure 1*;
3. Press the emergency button on the remote control;

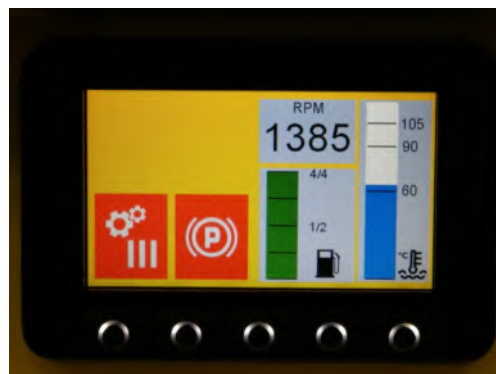

Figure 1: Main menu

NOTE: This function will not work if the remote control is active!!!

- From the menu shown in *Figure 1*, press the DOWN key twice (see section 6.9.1) to access the forced regeneration menu *Figure 2*, then press the ENTER key for a few seconds (see *Figure 2*);



Figure 2: Regeneration menu

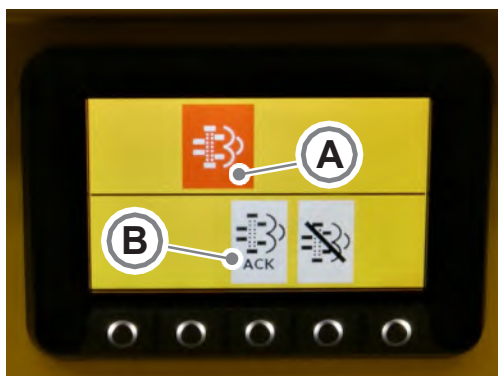

Figure 3



Figure 4

- At this point, an indicator (A) (*Figure 3*) appears, prompting you to confirm the activation of the regeneration function. The indicator (B) will then start to flash. To confirm the activation, press and hold the ENTER button (see section 6.4.1) for a few seconds until the indicator (C) appears (*Figure 4*).
- The machine will now start the forced stationary regeneration process;
- Do not move the machine stationary until the regeneration process has ended.

To inhibit forced stationary regeneration: press the HOME button (see section 6.4.1); the indicator light above the button turns red. Press the HOME button again to enable the system.



7.1 - FAULTS

Provided that the majority of operating defects occur due to improper use of the machine, the table below indicates some possible malfunctions that could occur and the measures to be taken to eliminate them.

NOTE: in the case the anomaly or the cause that has caused it do not come under the defects indicated, contact the McConnell company.

7.1.1 - DIESEL ENGINE

Malfunction	Cause	Solution
A symbol appears when the engine is running		
Engine oil pressure symbol	Low engine oil level	Top up the oil to the required level
	Engine oil level too high	
	Engine oil filter clogged	Replace the engine oil filter
Engine coolant symbol	Engine coolant level low	Top up the engine coolant
	Radiator fins dirty	Clean the radiator fins
	Engine coolant leakage	Contact McConnell's support service
	Timing belt loose or damaged	Adjust the tension of the belt or replace it
	Engine coolant pump faulty	Contact McConnell's support service
Battery symbol	Timing belt loose or damaged	Adjust the tension of the belt or replace it
	Battery low	Check the battery
	Alternator faulty	Contact McConnell's support service
The engine does not start when switched on, a symbol appears		
Battery symbol	Alternator faulty	Contact McConnell's support service
Engine oil pressure symbol	Engine oil pressure switch faulty	
	Engine oil level low / no oil	Top up the oil to the required level
	Engine oil filter clogged	Replace the engine oil filter
The engine does not start		
The starter motor is working but the engine does not start	No fuel	Refuel and prime the fuel system
	Air in the fuel system	Bleed the fuel system
	Unsuitable type of diesel	Replace with a suitable type of diesel
	Fuel filter clogged	Replace the fuel filter
	Low fuel injection	Contact McConnell's support service
	Compressed air leaking from the intake / discharge valves	
	Engine stop solenoid faulty	

If the fault or the reason for it is not indicated in the list of faults shown, contact McConnell in order for repairs to be carried out.

Malfunction	Cause	Solution
The starter motor does not work or rotates too slowly (the motor can be turned by hand)	The battery needs to be recharged	Check the electrolyte / recharge the battery
	Bad cable connection to the battery terminals	Clean the terminals, re-tighten
	Start-up relay faulty	Contact McConnel's support service
	Starter motor faulty	
The motor cannot be turned by hand	Internal parts of the motor seized or damaged	
White or black exhaust gases		
Black exhaust gases	Engine overloaded	Reduce the load
	Air filter elements clogged	Clean / replace the elements
	Unsuitable type of diesel	Replace with a suitable type of diesel
	Injection faulty	Contact McConnel's support service
	Excessive intake / discharge valve clearance	
	EGR valve faulty	
White exhaust gases	Unsuitable type of diesel	Replace with the recommended type of diesel
	Injection faulty	Contact McConnel's support service
	Fuel injection timing delay	
	Engine oil	

If the fault or the reason for it is not indicated in the list of faults shown, contact McConnel in order for repairs to be carried out.

7.1.2 - TROUBLESHOOTING CONTROL UNIT LE70

Error	Cause	Solution
10	Longitudinal machine angle excessive with respect to the ground	Decrease the inclination of the machine
11	Transverse machine angle excessive with respect to the ground	Decrease the inclination of the machine
12	Water temperature fairly high	Allow the engine to cool down
13	Water temperature high, stop the stump grinder for safety	Allow the engine to cool down
14	Water temperature very high, switch off the engine for safety	Allow the engine to cool down
40	LE70 1 safety relay contact error	Check the control unit power supplies, save the parameters. If the error persists, replace the control unit
41	LE70 2 safety relay contact error	Check the control unit power supplies, save the parameters. If the error persists, replace the control unit
42	LE70 3 safety relay contact error	Check the control unit power supplies, save the parameters. If the error persists, replace the control unit
43	LE70 4 safety relay contact error	Check the control unit power supplies, save the parameters. If the error persists, replace the control unit
44	Control unit RTC error	Save the parameters. If the error persists, replace the control unit
50	LE70 CRC Error	Reprogram the control unit, save the parameters. If the error persists, replace the control unit
51	LE70 CRC Error	Reprogram the control unit, save the parameters. If the error persists, replace the control unit
52	LE70 CRC Error	Reprogram the control unit, save the parameters. If the error persists, replace the control unit
53	LE70 CRC Error	Reprogram the control unit, save the parameters. If the error persists, replace the control unit
55	No power to the LE70	Make sure there is power on pins A33 and B33

If the fault or the reason for it is not indicated in the list of faults shown, contact McConnel in order for repairs to be carried out.

Error	Cause	Solution
60	Receiver error message CAN Autec Radio	Check the receiver, check the CAN line, check the LE70. If the error persists, replace the IO Bridge
61	Receiver error message CAN Autec Radio	Check the receiver, check the CAN line, check the LE70. If the error persists, replace the IO Bridge
62	Receiver error message CAN Autec Radio	Check the receiver, check the CAN line, check the LE70. If the error persists, replace the IO Bridge
63	Receiver error message CAN Scanreco Radio	Check the receiver, check the CAN line, check the LE70. If the error persists, replace the IO Bridge
64	Receiver error message CAN Scanreco Radio	Check the receiver, check the CAN line, check the LE70. If the error persists, replace the IO Bridge
65	System error Scanreco radio	If the error persists, replace the radio transmitter / receiver unit
70	Radio control lever value incorrect	Check the remote control, check the control unit parameters. If the error persists, replace the remote control
71	Radio control lever value incorrect	Check the remote control, check the control unit parameters. If the error persists, replace the remote control
72	Radio control lever value incorrect	Check the remote control, check the control unit parameters. If the error persists, replace the remote control
73	Radio control lever value incorrect	Check the remote control, check the control unit parameters. If the error persists, replace the remote control
74	Radio control lever value incorrect	Check the remote control, check the control unit parameters. If the error persists, replace the remote control
75	Radio control lever value incorrect	Check the remote control, check the control unit parameters. If the error persists, replace the remote control
76	Radio control lever value incorrect	Check the remote control, check the control unit parameters. If the error persists, replace the remote control
77	Radio control lever value incorrect	Check the remote control, check the control unit parameters. If the error persists, replace the remote control
80	Receiver error message CAN from machine display	Check the display, check the CAN line, check the LE70. If the error persists, replace the display
81	Machine display system error	If the error persists, replace the display
90	Machine inclinometer system error	If the error persists, replace the inclinometer
91	Receiver error message CAN from the inclinometer;	Check the inclinometer, check the CAN line, check the LE70, if the error persists, replace the inclinometer
200	Engine protection alarm;	See SPN and FMI codes to understand the reason for the alarm
201	Engine warning alarm;	See SPN and FMI codes to understand the reason for the alarm
202	Stop engine alarm;	See SPN and FMI codes to understand the reason for the alarm
203	Engine fault alarm	See SPN and FMI codes to understand the reason for the alarm
204	Engine alarm	Battery voltage: the voltage measured by the ECU is outside the target range
205	Engine alarm	Battery voltage: the voltage measured by the ECU is outside the target range; the ECU activates a system response
206	Engine alarm	Coolant level: the level of coolant calculated by the ECU is less than the minimum permitted amount
207	Engine alarm	Air heater relay indicator: the energy consumption measured by the ECU does not fall within the permissible range or the maximum permissible temperature of the ECU component that powers the lamp has been exceeded
208	Engine alarm	Coolant temperature sensor: the sensor voltage measured by the control unit does not fall within the permissible range; the temperature of the coolant calculated by the control unit is questionable when compared to the oil temperature, or the value received via the CAN is incorrect
209	Engine alarm	Coolant temperature: the temperature of the coolant calculated by the control unit is higher than the permissible range; the ECU activates a system response

If the fault or the reason for it is not indicated in the list of faults shown, contact McConnell in order for repairs to be carried out.

Error	Cause	Solution
210	Engine alarm	Oil level indicator: the energy consumption measured by the ECU does not fall within the permissible range or the maximum permissible temperature of the ECU component that powers the lamp has been exceeded
211	Motor CAN message reception error;	Check the engine, check the CAN line, check the LE70. If the error persists, check the engine control unit.
500	Problems with output pin A24 of control unit LE70	Check the cable; Controller output error;
501	Problems with output pin A13 of control unit LE70	Check the cable; Controller output error;
502	Problems with output pin A01 of control unit LE70	Check the cable; Controller output error;
503	Problems with output pin A02 of control unit LE70	Check the cable; Controller output error;
504	Problems with output pin A03 of control unit LE70	Check the cable; Controller output error;
505	Problems with output pin A04 of control unit LE70	Check the cable; Controller output error;
506	Problems with output pin A05 of control unit LE70	Check the cable; Controller output error;
507	Problems with output pin A06 of control unit LE70	Check the cable; Controller output error;
508	Problems with output pin A07 of control unit LE70	Check the cable; Controller output error;
509	Problems with output pin A08 of control unit LE70	Check the cable; Controller output error;
510	Problems with output pin A09 of control unit LE70	Check the cable; Controller output error;
511	Problems with output pin A10 of control unit LE70	Check the cable; Controller output error;
512	Problems with output pin A11 of control unit LE70	Check the cable; Controller output error;
513	Problems with output pin A12 of control unit LE70	Check the cable; Controller output error;
514	Problems with output pin A23 of control unit LE70	Check the cable; Controller output error;
515	Problems with output pin A35 of control unit LE70	Check the cable; Controller output error;
516	Problems with output pin B24 of control unit LE70	Check the cable; Controller output error;
517	Problems with output pin B13 of control unit LE70	Check the cable; Controller output error;
518	Problems with output pin B01 of control unit LE70	Check the cable; Controller output error;
519	Problems with output pin B02 of control unit LE70	Check the cable; Controller output error;
520	Problems with output pin B03 of control unit LE70	Check the cable; Controller output error;
521	Problems with output pin B04 of control unit LE70	Check the cable; Controller output error;
522	Problems with output pin B05 of control unit LE70	Check the cable; Controller output error;
523	Problems with output pin B06 of control unit LE70	Check the cable; Controller output error;
524	Problems with output pin B07 of control unit LE70	Check the cable; Controller output error;
525	Problems with output pin B08 of control unit LE70	Check the cable; Controller output error;
526	Problems with output pin B09 of control unit LE70	Check the cable; Controller output error;
527	Problems with output pin B10 of control unit LE70	Check the cable; Controller output error;
528	Problems with output pin B11 of control unit LE70	Check the cable; Controller output error;
529	Problems with output pin B12 of control unit LE70	Check the cable; Controller output error;
530	Problems with output pin B23 of control unit LE70	Check the cable; Controller output error;
531	Problems with output pin B35 of control unit LE70	Check the cable; Controller output error;

If the fault or the reason for it is not indicated in the list of faults shown, contact McConnel in order for repairs to be carried out.

7.1.3 - ELECTRICAL CIRCUIT

Malfunction	Cause	Solution
The lights are not properly lit even when the engine is running at a high speed.	Faulty cables.	Check and repair the defective terminals and cables.(*)
Lights are not steadily lit while the engine is running.	Defective fan belt tensioning.	Adjust belt tensioning.
The alternator charge indicator light does not turn off when the engine is running and accelerated.	Faulty alternator.	Replace.(*)
	Faulty cables.	Replace.
The starter does not run when the key is turned to the ignition position.	Faulty cables.	Check and repair.(*)
	Insufficient accumulator charge.	Charge the accumulator.
	Faulty main fuse.	Replace.
The starter pinion is engaged and then released.	Insufficient accumulator charge.	Charge the accumulator.
The starter makes the engine run slowly.	Insufficient accumulator charge	Charge the accumulator.
	Faulty starter motor	Replace.(*)
The starter deactivates before the engine starts.	Faulty cables	Check and repair.(*)
	Insufficient accumulator charge.	Charge the accumulator.
The alternator charge indicator light does not turn on when the engine is stopped (ignition key on "I").	Faulty light	Replace.(*)
	Faulty cables	Check and repair.(*)

(*) If the fault or the cause that caused it is not indicated in the tables below, contact McConnel for the necessary repair.

7.1.4 - HYDRAULIC SYSTEM

Malfunction	Cause	Solution
The pump makes a strange noise.	Faulty pump	Repair or replace.(*)
	Lack of oil in the tank	Fill to level
The equipment moves at low speed.	Faulty pump	Repair or replace.(*)
	Maximum pressure valve out of calibration or not closed due to impurities	Adjust or replace.(*)
	Dirty discharge filter	Replace the cartridge

(*) If the fault, or the cause that caused it, is not indicated in the tables below, contact McConnel for the necessary repair.

7.1.5 – DRIVE MOTORS

Malfunction	Cause	Solution
Oil leakage from the seals	Strengthening for prolonged storage	Clean the area and check after a few days
	Seals damaged or worn	Contact an authorised service centre
	Excessive quantity of lubricant	Check the oil level
Excessive vibrations and/or noise	Wheel reduction unit not installed correctly	Contact an authorised service centre
	Internal malfunction	
	Faulty or poorly lubricated bearings	
	Teeth with dents or chipping	
Multiple parking disc brake does not release	Lack of pressure in the braking circuit	Check the connection to the brake
	Adhesion of the discs due to parking time	Apply pressure to the brake and turn the wheel, starting the engine
	Faulty brake seals	Contact the service centre
Multiple parking disc brake does not lock	Residual pressure in the circuit	Check the hydraulic circuit
	Worn discs	Contact an authorised service centre
With the engine running, the wheel reduction unit does not turn	Incorrect engine installation	Check the coupling between the engine and the wheel drive
	Brakes locked	Check the braking system
	Internal malfunction	Contact an authorised service centre
	Wheel reduction unit disengaged	See the DISENGAGEMENT section
Excessive heating	Excessive or insufficient oil	Check the oil level
	Unsuitable lubricant	Check the type and status of the lubricant
	Faulty or poorly lubricated bearings	Contact an authorised service centre
	Multiple disc brake does not open fully	Check the brake opening pressure
	High heat outputs	Contact a service centre.

7.2 - WORKING WITH THE MACHINE

DANGER

Before moving the machine, ensure full knowledge of the function of the controls and safety standards associated with them. The operator must be in the vicinity of the machine. Before moving the machine, ensure that nobody is within the operating range of the machine and that the action range is free from obstacles. Exert caution before starting to reverse and always check for the presence of persons, work equipment or obstacles.

- Before starting to cut, check that there are no foreign bodies such as stones, pieces of metal or animals on the surface to be mowed;
- Only cut grass and light brushwood that the machine is capable of processing without difficulty;
- When mowing slopes always start from the bottom;
- Always turn round in an upwards direction;
- Never go down slopes with an incline of more than 45°;
- Never stand directly in the line of fall of the machine;

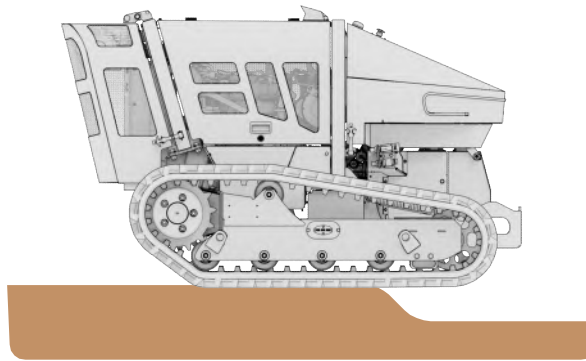

Never change the direction of the machine while moving on curbs, rocks or surfaces with large differences in height (greater than 20 cm). In these cases, always proceed perpendicular with respect to any obstacles.

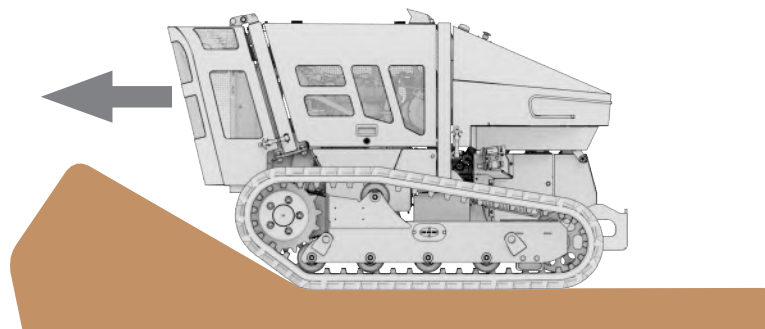

When reversing uphill, do not change direction in the transition area between the flat ground and the slope. If it is unavoidable to do so, carry out the manoeuvre gradually.

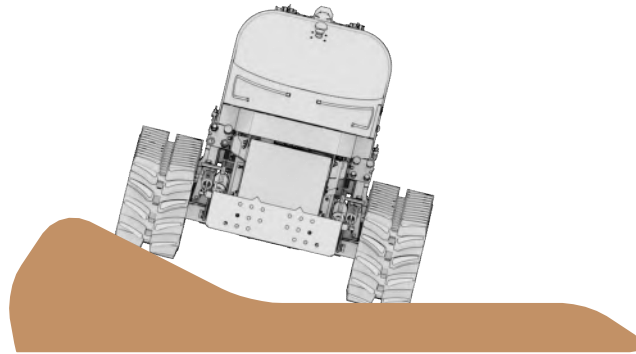

Avoid moving along the edge of a slope or on uneven ground with one track in a horizontal position and the other inclined or partially raised (with the machine inclined more than approximately 10°). In order not to damage the tracks, always proceed with the sliding blocks resting on the same horizontal plane.

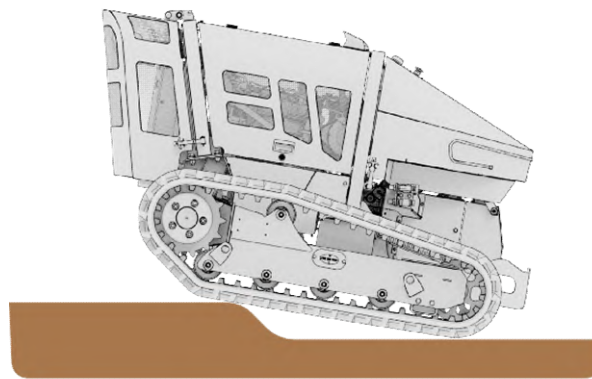

When the machine manoeuvres over an obstacle it creates an empty space between the bearing rollers and the tracks and there is a risk that the track may come out of its seat.

The same may happen if the machine is reversing uphill and you try to make a sharp turn. An empty space is created between the bearing roller, the front idler roller and the track, and there is a risk that it may come out of its seat.

When changing direction and the track cannot move sideways due to an obstacle, the track could become damaged and come out of its seat.

DANGER**SLIPPING OR OVERTURNING**

In order to avoid serious risks or the death of the operator it is prohibited to work on slopes that have hard surfaces (e.g. cement). Under these working conditions, always stand behind the machine or sufficiently far away from it (more than 20 metres)

7.3 - CONTROL STATION – OPERATOR WORK AREA

- The operator must always be at a minimum distance of at least 5 m from the machine.
- The operator should be provided with PPE (shoes, overalls, and goggles). If working in very dusty conditions, a protective face mask should be worn.
- The operator must try to position him or herself with respect to the machine in the recommended work cone both to avoid being outside the movement area of the machine and in the area where objects might be kicked up. Apart from when working on slopes with an inclination of more than 25°, for which the previous instructions should be followed.

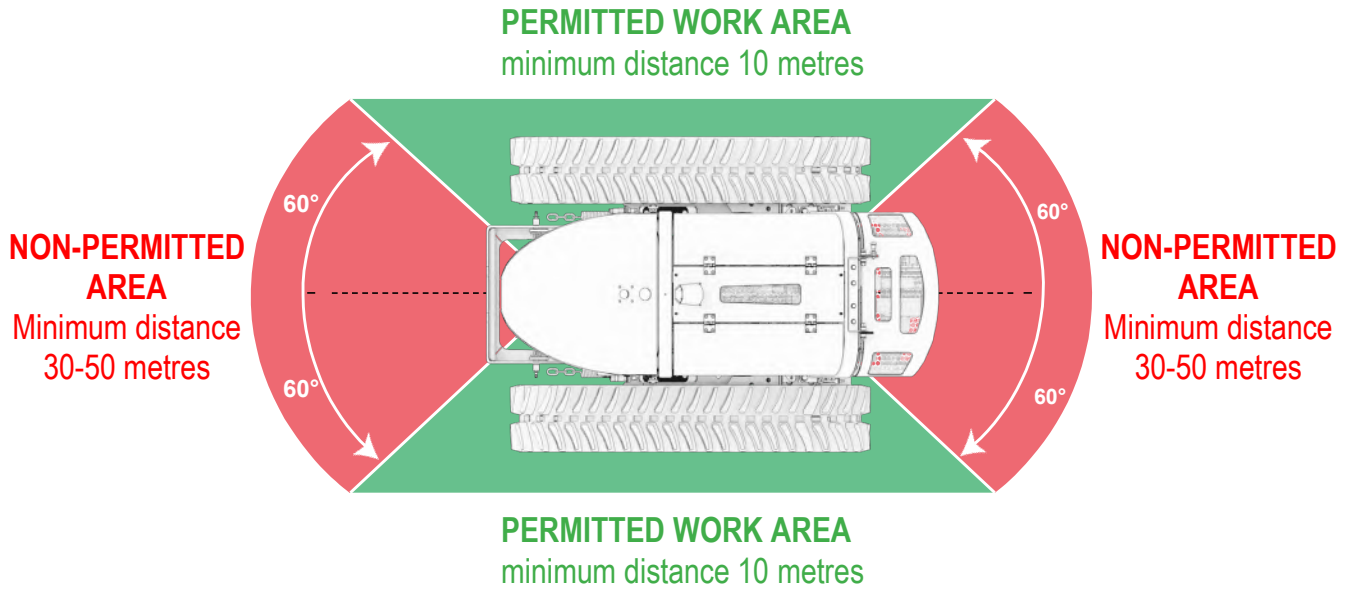

7 - TRANSPORTATION AND HANDLING

7.1 - LOADING AND UNLOADING OPERATIONS FOR ROAD TRAVEL

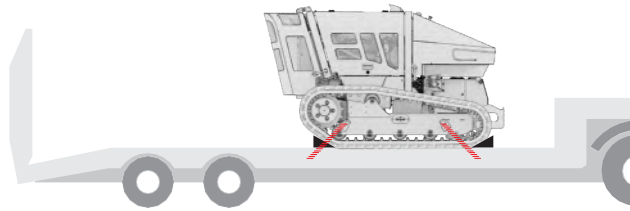

Use suitable vehicles with a carrying capacity of greater than 1600 kg to transport the machine. Use loading ramps, both of which are suitable for supporting a load of not less than 800 kg and which are hooked to the bed of the vehicle. The ramps must be positioned at the correct distance for the tracks and must make an angle with respect to the ground of no more than 50°. Once the machine has been loaded onto the vehicle, it is recommended to secure it to the bed of the vehicle using wire ropes or slings attached to the lifting rings indicated below.

ATTENTION



THEY COULD DAMAGE THE SURFACE!
 If studded tracks are mounted on the machine, cover the tracks with suitable rubber pads if it has to travel across concrete or tarmacked surfaces.



If the machine has to be lifted in order to load it, make sure that you use suitable chains or wire ropes for lifting and loading it.

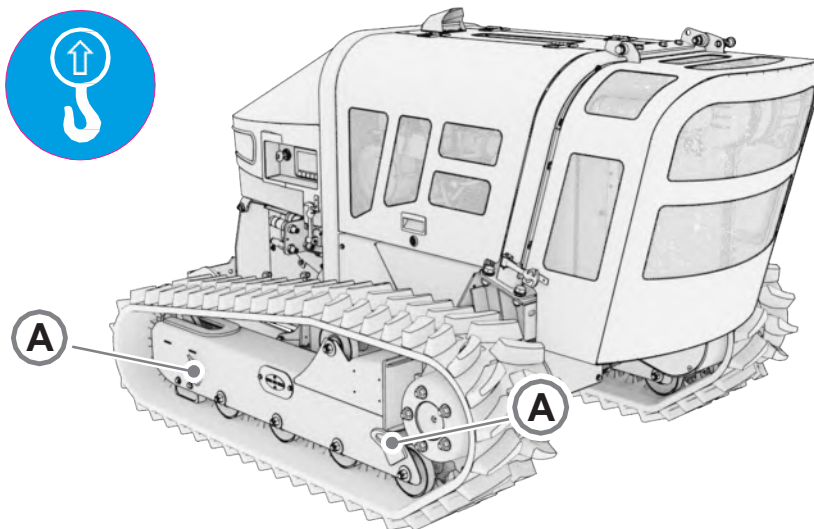

Connect the ropes or chains to the lifting rings provided (A). The machine should always be lifted without the equipment attached.

Note that when using ropes, slings, or chains to lift the machine, it is necessary to comply with the diagram below, indicating the minimum pulling angles.

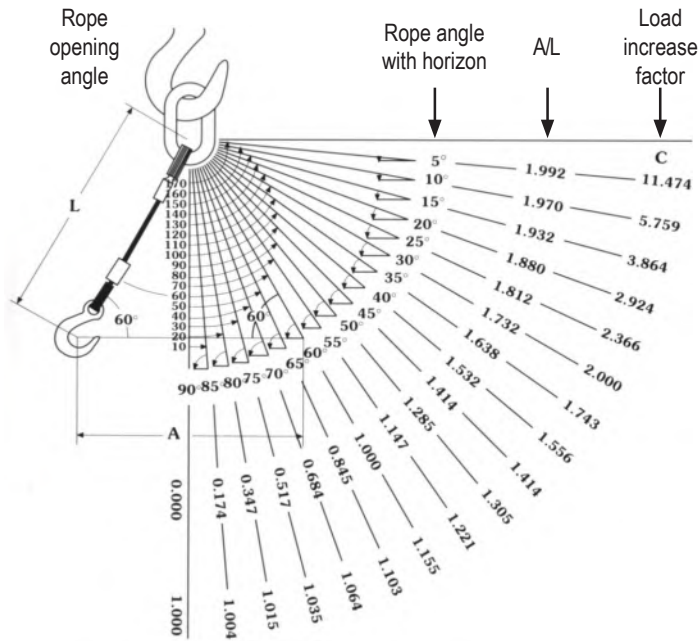

Angle at the top	Load increase factor
0°	1
10°	1.004
20°	1.015
30°	1.035
40°	1.064
50°	1.103
60°	1.155
70°	1.221
80°	1.305
90°	1.414
100°	1.556
110°	1.743
120°	2.000
130°	2.336
140°	2.924
150°	3.864
160°	5.759
170°	11.474

ATTENTION



Do not attach wire ropes or slings to the roll bar in order to lift the machine. This element is not designed for lifting the machine.

7.1.1 - IF THE MACHINE BREAKS DOWN

ATTENTION



If the motor or the hydraulic system break down, do not tow the machine. Only lift it:

- As seen in the previous section, lift the machine at the lifting points, using suitable ropes or chains;
- Do not attach wire ropes or slings to the roll bar in order to lift the machine. This element is not designed for lifting the machine.
- If equipment is attached to the machine, it must be disconnected and lifted at a later stage (refer to the equipment manual for lifting instructions).

7.2 - USING THE MANUAL CONTROL

If the machine has to be moved without using the remote control (e.g. remote-control batteries discharged), this can be done by connecting the manual control unit supplied with the machine.

To do this, follow the instructions below:

1. Remove the cap with the bayonet fitting (B) from the socket (A).
2. Insert the connector into the socket (A) and tighten the locking ring.

The engine can now be started using the ignition key.

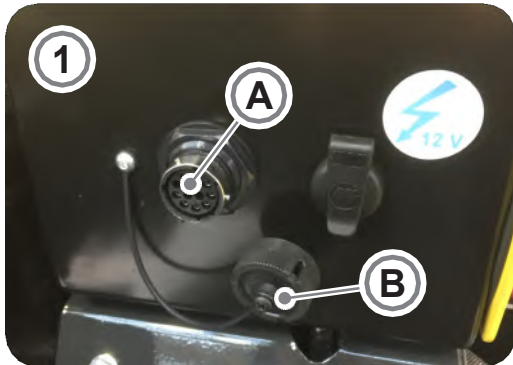

ATTENTION



- Only use the manual control in the event of emergencies.
- With the manual command on, all the remote-control operating functions are disabled.

7.2.1 - MANUAL CONTROL FUNCTIONS

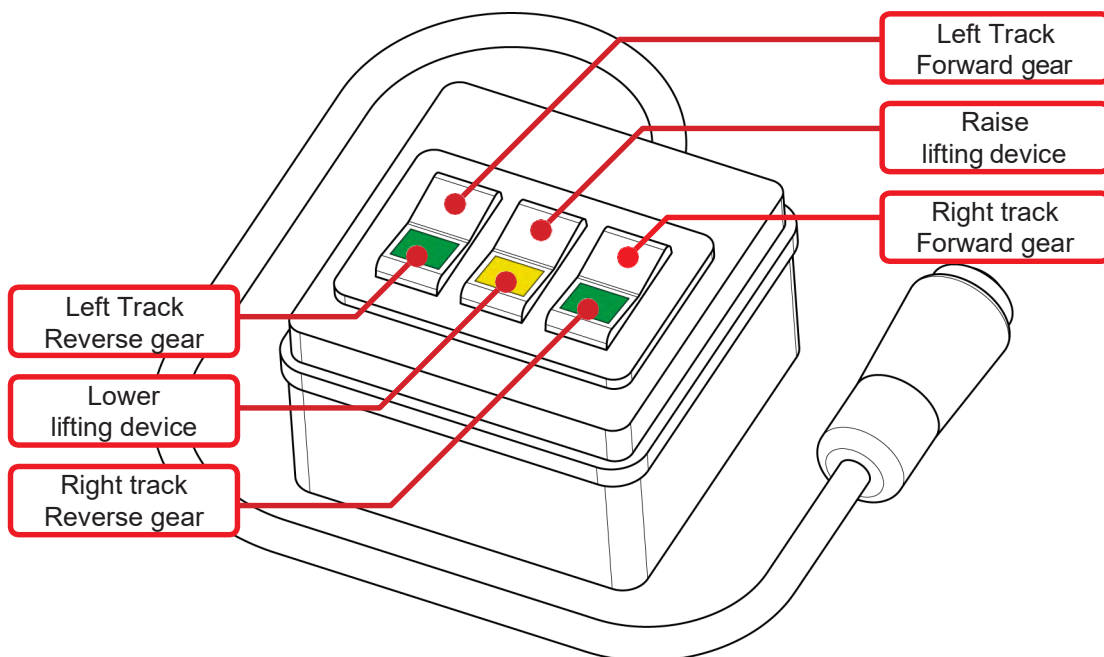

7.3 - STARTING THE ENGINE USING AN AUXILIARY BATTERY

If the engine has to be started using an external battery, proceed as follows:

1. Open the cover of the junction box (A) located close to the diesel pre-filter.
2. Connect one terminal of the red cable to the screw of the node and the other to the positive terminal (+) of the auxiliary battery.
3. Connect one terminal of the black cable to the earth by connecting it to the engine and connect the other to the negative terminal (-) of the auxiliary battery.
4. The engine can now be started using the ignition key.
5. Bring the speed of the diesel engine to 1000 rpm and wait for a few minutes before disconnecting the auxiliary battery.

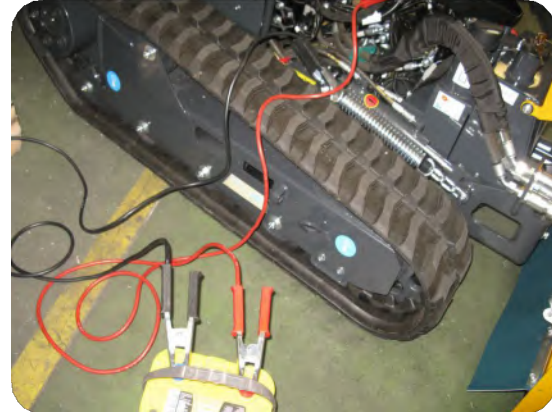
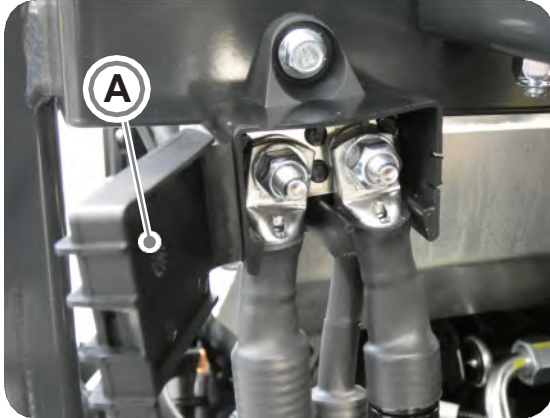

ATTENTION



DO NOT USE STARTING SYSTEMS SUCH AS ELECTRIC BATTERY CHARGERS OR BOOSTERS WHICH COULD DAMAGE THE ELECTRONIC CONTROL UNITS.

DANGER



- **Never check the battery charge by connecting the two poles with a metal object. Use a voltmeter.**
- **The battery earth connector (-) must always be the first to be disconnected and the last to be re-connected.**
- **The sulphuric acid in the battery electrolyte is poisonous. It can burn skin, pass through tissue and cause blindness if it enters the eyes.**
- **It should be noted that its compounds cause cancer and other harm to the reproductive organs. These substances are present in the battery poles, terminals and relative accessories. Wash your hands after touching them.**

8 - STORAGE

If the machine is stopped for long periods, it must be stored in a place protected from the elements to prevent damage. Before storing the machine, it is advisable to clean it thoroughly and to lubricate all the mechanical components to protect them from rust. Make sure that the storage temperature is between 0 °C and 40 °C.

Before storing the machine for long periods, it is advisable to perform the following operations:

- Clean the equipment (e.g. rotor and tools) from any cutting residues or other residues;
- Clean the machine thoroughly;
- Perform a visual inspection on the whole machine to identify any structural damage or deep scratches on the paintwork, and ensure that the original safety signs are still in good condition, legible and in their original positions;
- Grease all mechanical parts subjected to friction, the lock pins and all the machine parts no longer coated with their original paint layer in order to prevent rust from forming;
- Store the machine in a covered area and on a flat and firm surface;
- The machine must be stored with the equipment in the transport position;

8.1 - DISMANTLING, DECOMMISSIONING

If you no longer wish to use the machine, or parts of it, it is necessary to dismantle and decommission the machine. Before scrapping, the plastic/rubber parts and electrical and electronic materials must be separated. Collect any waste oil and dispose of it at the appropriate collection centres. Carry out these operations according to the regulations in force.

ATTENTION



If the machine or part of it has been taken out of service, the parts likely to cause any danger must be made harmless.

ATTENTION



It should be remembered that when replacing oils, batteries, rubber tubes, tyres, and any parts of the machine subject to separate disposal, reference must always be made to the applicable regulations. For the collection of waste oil contact your local authority or a member of the Oil Recycling Association and ask for disposal advice.

9 - MAINTENANCE

9.1 - INTRODUCTION

To obtain the machine's best performances and ensure maximum durability of all its components, the instructions for use and maintenance must be followed carefully by machine operators.

Therefore, we recommend our customers to carefully read these instructions and consult the manual any time they need advice on how to eliminate possible inconveniences. As the machine operates normally in contact with water, sand, earth, etc., regular lubrication is necessary, which assumes vital importance not only to ensure lengthy use of the machine, but also to keep down its running costs. For further information, please contact our service centre:

Contact McConnel's technical support service centre:

Telephone +44 (0)1584 873131
Email sales@mcconnel.com

9.2 - GENERAL INSTRUCTIONS

- Before carrying out any maintenance or inspecting and / or checking the machine, turn off the diesel engine and remove the ignition key.
- While disassembling and reassembling machine parts, always use suitable extractors, wrenches and tools to avoid damaging the specified components.
- To unlock parts that are stuck, use wooden hammers.
- Separate the parts of the various units and partially screw in the nuts on their corresponding pins or stud bolts. Clean the parts using brushes or rags, then wash using petroleum or warm water and remove all residues using compressed air.
- After sandblasting or finishing operations with abrasive elements, thoroughly clean the parts making sure that all abrasive powder residues have been removed completely.
- When reassembling the parts, make sure that they are clean. Then, lubricate them appropriately.
- Pay great attention to the safety rings and lock pins. Replace them immediately if you notice breaks.
- The maintenance operations of the machine and/or equipment must be carried out by authorised personnel.

9.3 - EXTRAORDINARY INTERVENTIONS

These are repairs or replacements of one or more components of the machine, which usually become necessary after a few years of efficient operation and which do not alter the characteristics of the machine. In the case of considerable changes, the manufacturer shall not be held responsible for possible hazards which might arise. These interventions must be performed by authorised personnel.

9.4 - FLUIDS AND GREASES

9.4.1 - TABLE

COMPONENT	RECOMMENDED LUBRICANT	INTERNATIONAL SPECIFICATIONS
ENGINE	Q8 FORMULA TRUCK 8600 10W-40	API CJ-4
HYDRAULIC SYSTEM Mineral Oil	ISO 46 Q8 HELLER 46	DIN 51 524, 2-HLP DIN 51 524, 3-HLP API CD, CE, CF
HYDRAULIC SYSTEM Biodegradable Oil	PANOLIN BIO HLP SYNTH E	FZG Test A/8.3/90 stage 12 ISO 15380 HEES
PINS AND BUSHINGS	MOLY GREASE EP NLGI2 or NLGI3EP GREASE	Black greased with lithium soap with molybdenum disulphide. For automatic greasing the use of added CONTACT GREASE NLGI2 with purple lithium soap is recommended
BEARINGS	PAKELO GREENPLEX EP NLGI 2 GREASE	EP ADHESIVE Grease, Aluminium complex soap

ATTENTION



- **When using biodegradable oils, avoid mixing them with more than 5% of other oils.**
- **The use of non-recommended lubricants and/or greases will result in invalidity of the warranty.**

9.4.2 - COOLANT

Q8 ANTIFREEZE LONG LIFE is used in the RC40/T400 as the coolant.

- Q8 ANTIFREEZE LONG LIFE diluted in deionised/demineralised water, a permanent coolant that can be used all year round.
- To ensure perfect mixing, it is essential to mechanically mix the antifreeze with the dilution water.
- The antifreeze protection depends on the proportion of Q8 ANTIIFREEEE LONG LIFE diluted in water.

Volume to dilute out of total	%	33	50
Temperature reached for the appearance of the first crystals	°C	-18	-38

- To ensure adequate corrosion protection, the coolant must contain at least 33% Q8 ANTIFREEZE LONG LIFE.
- We recommend using at least 50% in volume of Q8 ANTIFREEZE LONG LIFE in the final mix.
- IT IS advisable to dilute with deionised water.

Q8 ANTIFREEZE LONG LIFE meets the main international specifications for antifreeze: ASTM D 3306; ASTM D 4656; ASTM D 4985, ASTM D 6210; JIS K 2234; SAE J 1034.

9.4.3 - FUEL

DANGER



- **Do not use diesel filling systems that use auxiliary electric pumps without the written consent of McConnell.**
- **It is forbidden to tamper with or modify the fuel supply system and/or electrical system.**

DANGER



- **When handling fuel or coolant, do not smoke or work near a source of heat or sparks.**
- **Store flammable fluids away from fire hazards. Do not incinerate or burn containers; make sure the machine is free from dirt, grease or inflammable residues.**

- We recommend using standard-compliant fuels:

Fuel specifications	Position
ISO 8217 DMX	International
ASTM D975 N.1D S15 N.2D S15	USA
EN590×96	European Union
BS 2869-A1 or A2	United Kingdom
JIS K2204 class No.2	Japan
KSM-2610	Korea
GB252	China

- Other fuels with different specifications can damage the engine or reduce its power. For further details and/or explanations, consult the annexed engine manual.
- When refuelling, check there is no condensate on the fuel tank cover. Do not remove the condensate water on the bottom.
- Having run out of fuel or after the fuel filter has been changed, bleed the air from the pipes.

9.5 - ENGINE MAINTENANCE

9.5.1 - ENGINE OIL LEVEL CHECK

ATTENTION



- The motor oil level must be checked *daily*.
- The engine oil must be chosen very carefully; refer to the table in section 9.4.1.

The level of the engine oil can be checked with the graduated rod (A). The level must be between the MIN. and MAX. signs. The engine oil level must be checked with the engine cold and with the machine parked on flat surface.



If the engine oil level is near the MIN sign, restore it by unscrewing the cap (B) and adding oil until the level is between MIN. and MAX. To check this situation while topping up, wait a few moments before carrying out the check.

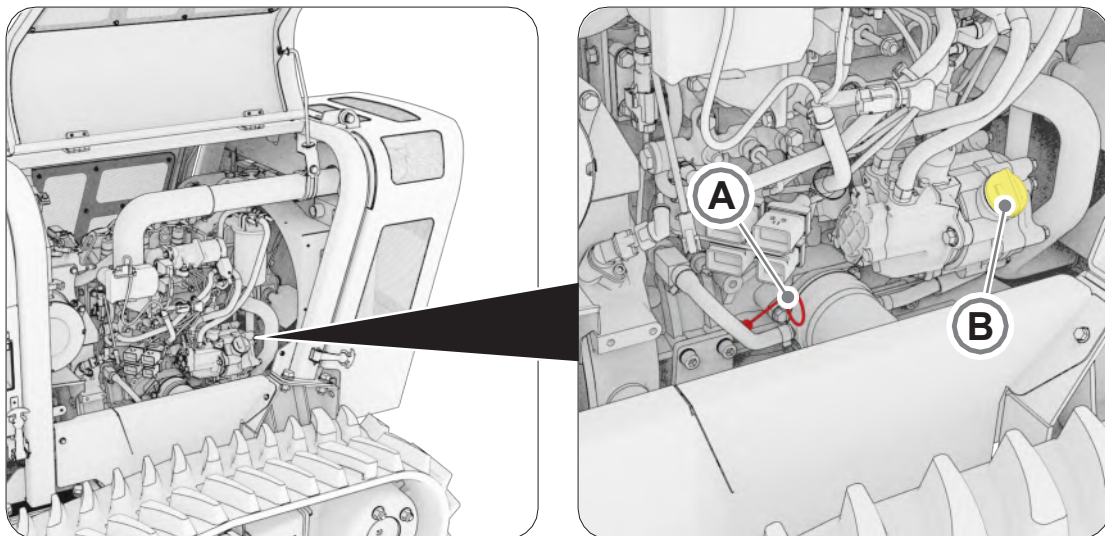

DANGER



- When the engine has just been switched off it may be very hot. Therefore, do not check the engine oil until the engine has cooled down.
- When checking the oil level or filling up, use protective clothing.

9.5.2 - FILTER AND ENGINE OIL CHANGE

ATTENTION



- After the first 50 hours of running in, the engine oil and filter must be replaced.
- Thereafter, replace the engine oil and filter every 250 working hours.
- Quantity of oil to use: approx. 7 litres
- The engine oil must be chosen very carefully; refer to the table in section 9.4.1.

WARNING



- The used oil and filter are classified as hazardous waste and must be disposed of correctly.
- Do not dispose of with household waste.
- Contact your local authorities, support centre or dealer for disposal/recycling centres.

DANGER



- Do not carry out these operations if the engine has just been switched off; wait until the engine is warm (40-45°C).
- Oil spilled during the replacement may cause slipping; wear protective garments and non-slip footwear and remove any traces of oil.

Perform the operations listed below to replace the filter and thermal motor oil:

1. Run the engine for approximately five minutes at idle speed to warm the oil and then turn it off;
2. Position the machine on a level surface, switch the engine off and remove the key;
3. Remove the bottom protection (A) by first unscrewing the eight screws (B) with a 13-mm spanner;
4. Place a container under the engine to collect the used oil;
5. Unscrew the oil sump drain cap (C) with a 19-mm spanner;
6. Clean the inspection and top-up area to reduce the possibility of contaminating the engine oil with impurities.

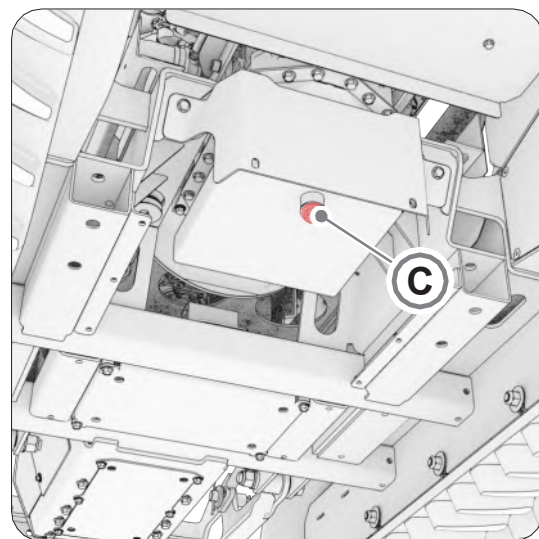
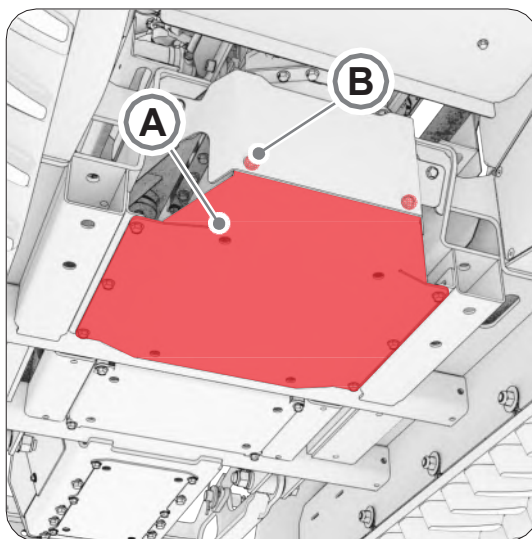

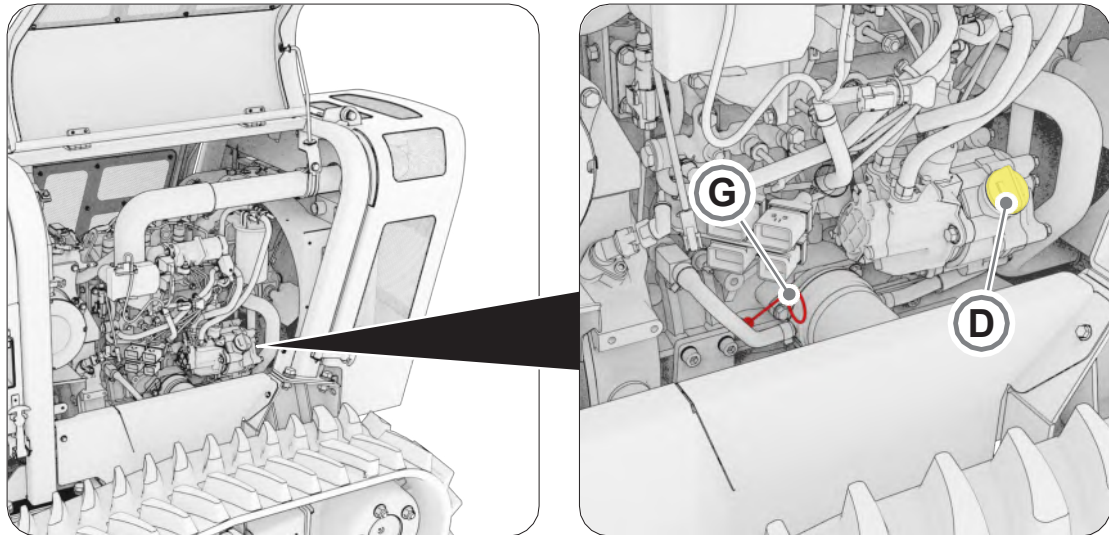

7. Unscrew the oil filler cap (D);
8. Retighten the oil sump drain cap (C) once all the oil has drained out;
9. Remove the side guard (E);
10. Unscrew the filter cartridge (F) anticlockwise and remove it;

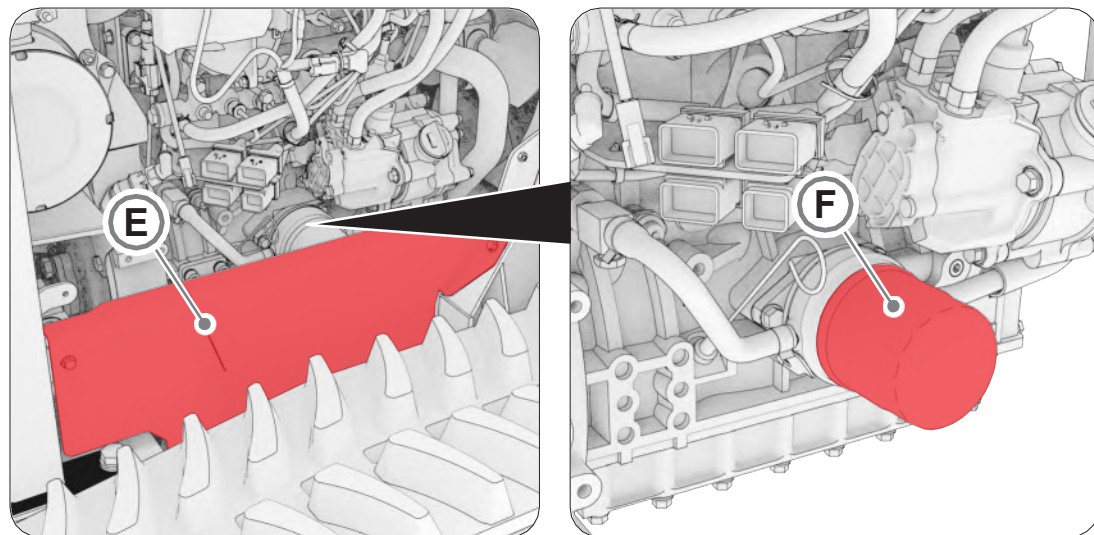

11. Apply a film of clean oil to the new filter in the external and internal seals, and the filter thread;
12. Dry the sealing head of the filter thoroughly with a clean rag and reinstall the filter, tightening it with the wrench (max. torque 19.6 - 23.5 Nm);
13. Fill the sump with a suitable engine oil (see the lubricants and fluids table in section 9.4.1) and close the filler cap (D).
14. Start the engine and leave it running for approximately five minutes at idle speed. Then, turn the engine off and after approximately three minutes, check the oil level using the dipstick (G). Top up if necessary.
15. Reassemble the guards (A) and (E).

9.5.3 - COOLANT LEVEL CHECK

ATTENTION



- Check the coolant level *daily or before each use*.
- The coolant must be chosen very carefully; refer to the table in section 9.4.2.

DANGER



- **Danger of burns due to very hot coolant!**
- **The cooling system is under pressure! If pressurised coolant spurts out, it may cause serious injuries.**
- **Before removing the cap, loosen it slowly until the first stop to relieve the pressure inside.**
- **Remove the fuel filler cap only when it has cooled down enough to be touched with bare hand.**
- **When handling fuel or coolant, do not smoke or work near heat sources or sparks.**

ATTENTION



- **If the level is too low, it can cause irreparable damage to the engine.**
- **Pressurised tank. Do not open the cap when the engine is hot.**

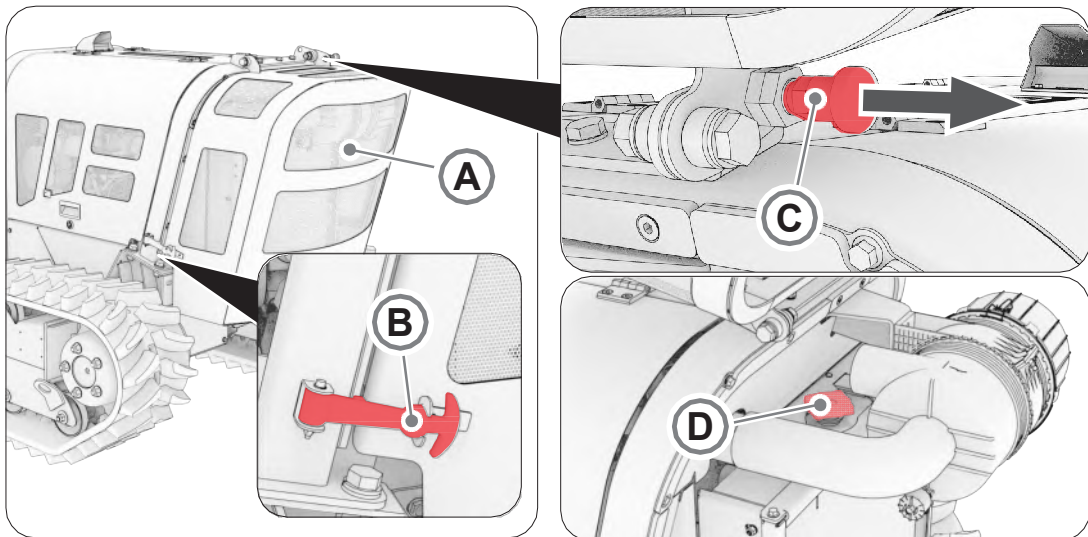

Proceed as follows to check the coolant level:

1. Detach the two rubber stay rods (B) securing the bonnet (A).
2. Pull the locking pin (C), raise the bonnet, then block it by releasing the pin.
3. Slowly unscrew the radiator cap (D) in order to release the pressure inside and visually check the coolant level.
4. The level of coolant must be above the radiator elements by two or three centimetres.
5. If the level is low, top it up by adding coolant to the radiator. Close the cap (D) again.
6. Pull the locking pin (C). Lower the bonnet (A) and block it with the two stay rods.

9.5.4 - COOLANT REPLACEMENT

ATTENTION

- The coolant must be replaced *every 1000 working hours or after 1 year.*
- Before removing the cap, loosen it slowly until the first stop to relieve the pressure inside.
- The coolant must be chosen very carefully; refer to the table in section 9.4.2.

DANGER

- Danger of burns due to very hot coolant!
- The cooling system is under pressure! If pressurised coolant spurts out, it may cause serious injuries.
- Before removing the cap, loosen it slowly until the first stop to relieve the pressure inside.
- Remove the fuel filler cap only when it has cooled down enough to be touched with the bare hand.
- When handling fuel or coolant, do not smoke or work near heat sources or sparks.

DANGER

- Dispose of spilled coolant in accordance with the relative standards and do not allow it to penetrate the ground.
- The improper disposal of waste can threaten the environment and the ecological system. For disposal or correct recycling of waste, contact the relevant agencies.
- The protective agents of the cooling system must be ordered from McConnel partners.
- Never use the engine without coolant, not even for a short time!

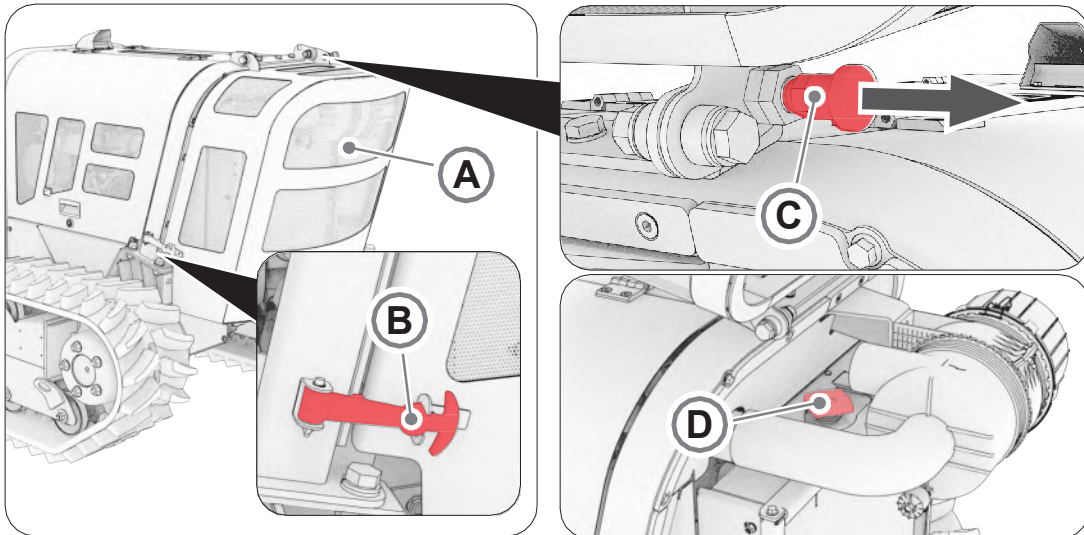

Proceed as follows to check the coolant level:

1. Position the machine on a flat surface and switch off the engine;
2. Allow the coolant and engine to cool down;
3. Detach the two rubber stay rods (B) securing the bonnet (A).
4. Pull the locking pin (C), raise the bonnet and block it by releasing the pin.
5. Slowly unscrew the radiator cap (D) to the first stop to release the pressure inside the circuit. When done, remove it.

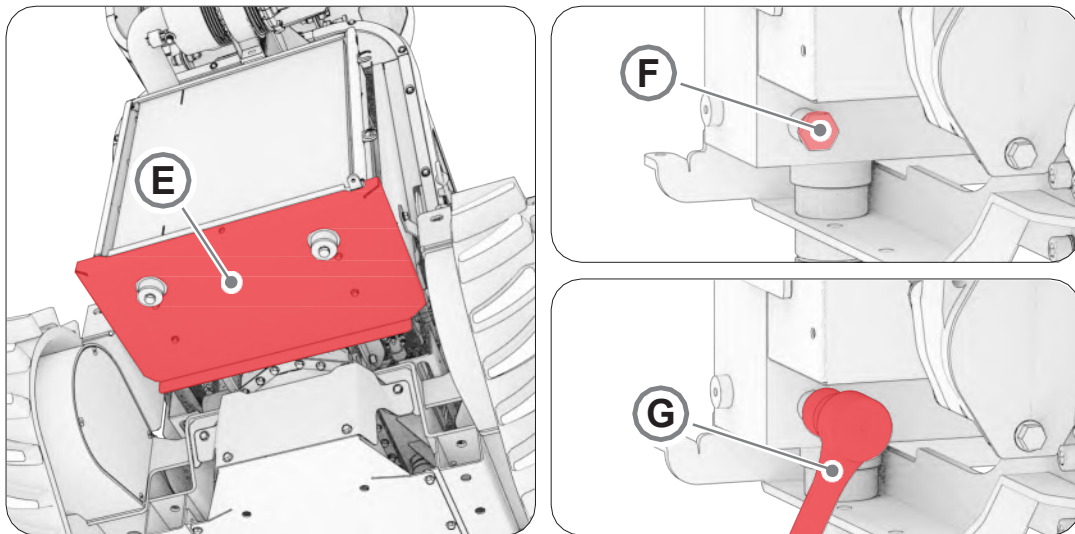

6. Remove the guard (E) by unscrewing the four screws which hold it in place using a 10-mm spanner.
7. Place a container under the engine and radiator to collect the used coolant.
8. Unscrew the drain cap (F) from the radiator, with a socket wrench (G) with a 22-mm socket.
9. Drain the coolant from the radiator;

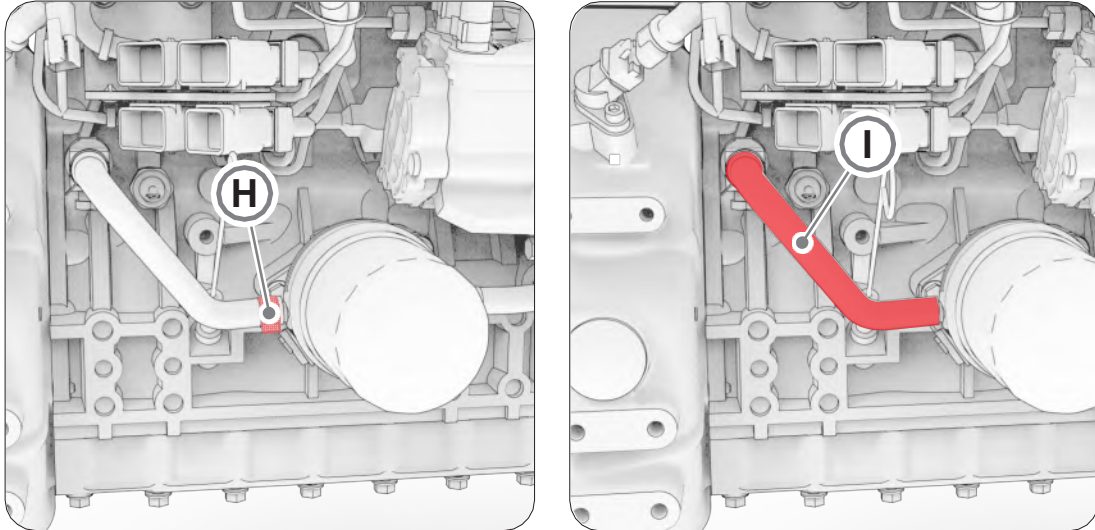

10. Drain the coolant from the monobloc removing the hose clip (**H**) and detaching the hose pipe (**I**) from the oil filter;
11. After having drained the coolant, wash the radiator and monobloc in order to remove any rust, scale and contaminants;
12. Reconnect the hose pipe (**I**) and secure it with the clip (**H**);
13. Put the drain cap (**F**) back on and tighten it with a 35 Nm torque;
14. Fill the engine and radiator with the coolant making sure that the liquid level is between two and three centimetres above the radiator elements;
15. Screw up the radiator top-up cap (**D**);
16. Start the engine and leave it running until it reaches normal working temperature;
17. Allow the coolant and engine to cool down;
18. Check the coolant level again and top it up, if necessary;
19. Reassemble the guard (**E**) and close the bonnet (**A**).

9.5.5 - FUEL LEVEL CHECK

ATTENTION



- Check the fuel level *daily* or *before each use*.
- The fuel must be chosen very carefully; refer to the table in section 9.4.3.

DANGER



- When more fuel is added, avoid spilling it as this may cause a risk of fire.
- If some fuel is spilled accidentally, clean the area very carefully.
- Fuel is a highly flammable liquid so do not use open flames and do not smoke while refuelling. Also hold the nozzle or the canister close to the filler neck to prevent sparks.
- When adding fuel wear protective clothing.

The fuel level is checked visually with the machine on the flat, on the remote control or machine display.

If the level falls to reserve a warning light comes on and a beeper sounds.

To top up the fuel:

1. Turn off the engine.
2. Open the tank cap (A) with the key supplied with the machine and fill it. Do not fill the tank right to the top. Leave a gap for expansion.
3. Lock the cap with the key.

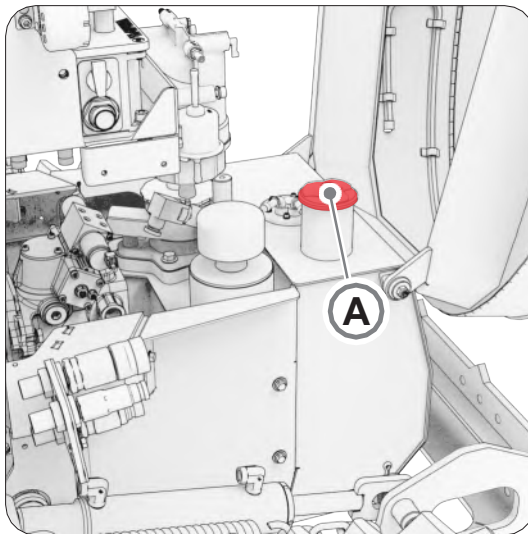

9.5.6 - DRAINING AND BLEEDING THE FUEL SEPARATOR

ATTENTION



- Check the fuel separator every 50 working hours or weekly.
- When contaminants appear, remove them immediately, DO NOT wait for scheduled maintenance to be carried out.

DANGER



- This must be carried out with the engine cold and switched off.
- As fuel is very flammable, keep open flames away from it and do not smoke during this operation.
- Clean up any area affected by spilled fuel immediately.
- During this operation, wear protective clothing.

ATTENTION



DO NOT use the starter motor to turn over the engine in order to prime the fuel system. This can cause the starter motor to overheat and damage the coils, the pinion and/or the crown gear.

Drain the fuel separator every time contaminants, such as water, collect at the bottom of the bowl. There is a red float ring in the bowl that rises with the level of water to indicate how much needs to be drained.

Proceed as follows to drain the fuel separator:

1. Place a suitable container under the separator to collect any contaminants.
2. Turn off the fuel valve (**A2**) by moving it into the "OFF" position.
3. Loosen the drain valve (**B**) on the bottom of the separator to drain any water there may be in the separator. If the water doesn't drain, loosen the vent screw (**C**).
4. Tighten the drainage valve (**B**) by hand.
5. Open the fuel valve (**A1**) by moving it to the "ON" position.
6. Prime the system by turning the ignition key to the "ON" position for 10 to 15 seconds in order to refill the bowl of the separator.

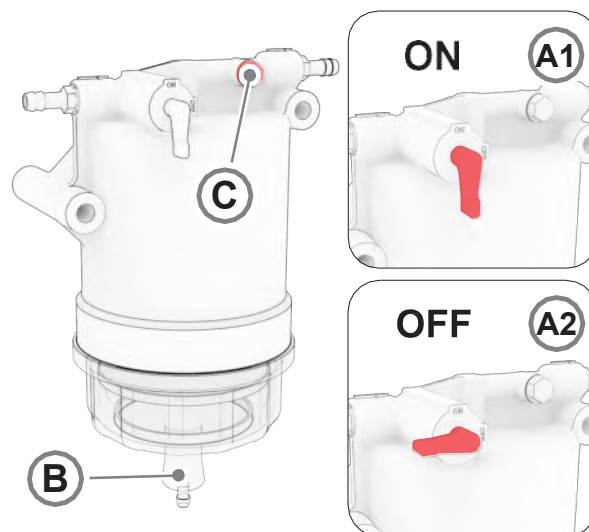

9.5.7 – PRIMARY FUEL FILTER REPLACEMENT

ATTENTION



- The cartridge must be replaced every 500 working hours.
- When contaminants appear, remove them immediately, DO NOT wait for scheduled maintenance to be carried out.

DANGER



- In certain specific conditions, diesel is flammable and explosive.
- Never use diesel as a cleaning agent.
- When a component is removed from the fuel supply system to carry out maintenance (e.g. to replace the fuel filter), place an approved container under the opening to collect the fuel.
- Do not use rags to collect the fuel. The vapours from the rags are flammable and explosive.
- Clean up any area affected by spilled fuel immediately.
- Wear protective goggles. The fuel supply system is pressurised and the fuel could spurt out when any of the components are removed.
- Lack of caution may cause death or serious injury.
- This must be carried out with the engine cold and switched off.
- As fuel is very flammable, keep open flames away from it and do not smoke during this operation.

ATTENTION



DO NOT use the starter motor to turn over the engine in order to prime the fuel system. This can cause the starter motor to overheat and damage the coils, the pinion and/or the crown gear.

WARNING



- If the separator and/or the filter inside it are damaged, they should be replaced immediately.
- Observe the regulations in force in the country of use for the correct disposal of hazardous material, such as engine oil, diesel and engine coolant. Contact local authorities or a recycling centre.
- Never dispose of hazardous material irresponsibly by pouring it down drains, on the ground or into groundwater or waterways.
- Failure to observe these procedures could cause serious damage to the environment.

1. Place an approved container under the bowl (F) of the fuel separator to collect the contaminants.
2. Close the fuel separator valve by turning it to OFF, (A2).
3. Loosen the drain valve (G) and drain the diesel and contaminants. If the water doesn't drain, loosen the vent screw (B).
4. Unscrew the bowl (F) by turning it to the left and remove it from the separator housing (C).
5. Hold the bowl firmly to prevent fuel from spilling out. In the event of spillages, clean the area affect thoroughly.
6. Remove the floating ring (E) from the bowl (F). Drain the residual fuel in the bowl.
7. Remove the cartridge (D) from the fuel separator housing (C).
8. Clean the inside of the bowl (F).
9. Check the bowl O-ring. Replace it, if necessary.
10. Put the floating ring (E) back in the bowl (F).
11. Insert the new cartridge (D) in the fuel separator housing (C).
12. Screw the bowl back into the fuel separator housing (C), by turning it to the right. Tighten the sump by hand with a 27÷33 Nm torque.
13. Close the drain valve (G) and then, tighten it to 1÷2 Nm.
14. Open the fuel separator valve by turning it to ON, (A1).
15. Prime the system by turning the ignition key to the ON position for ten to fifteen seconds in order to refill the bowl of the separator.
16. Check for leaks.

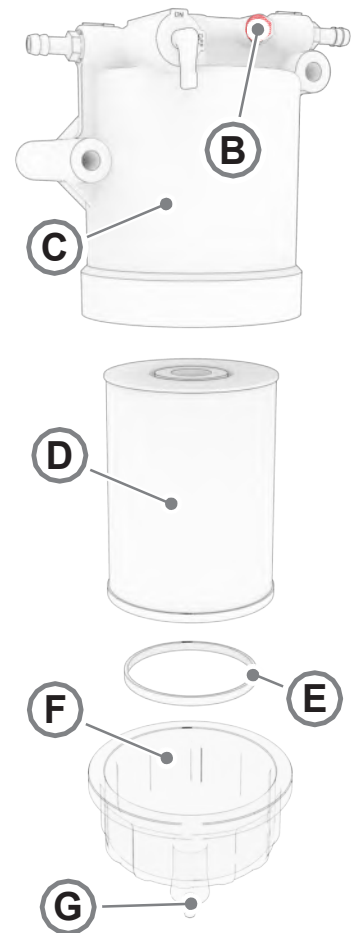
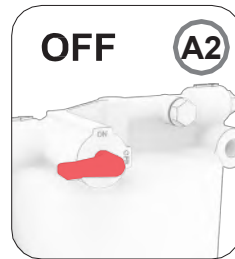
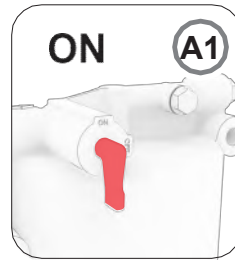

9.5.8 - REPLACING THE FUEL FILTER

ATTENTION



The fuel filter must be replaced every 500 working hours.

DANGER



- In certain specific conditions, diesel is flammable and explosive.
- Never use diesel as a cleaning agent.
- When a component is removed from the fuel supply system to carry out maintenance (e.g. to replace the fuel filter), place an approved container under the opening to collect the fuel.
- Do not use rags to collect the fuel. The vapours from the rags are flammable and explosive.
- Clean up any area affected by spilled fuel immediately.
- Wear protective goggles. The fuel supply system is pressurised and the fuel could spurt out when any of the components are removed.
- Lack of caution may cause death or serious injury.
- This must be carried out with the engine cold and switched off.
- As fuel is very flammable, keep open flames away from it and do not smoke during this operation.

ATTENTION



DO NOT use the starter motor to turn over the engine in order to prime the fuel system. This can cause the starter motor to overheat and damage the coils, the pinion and/or the crown gear.

WARNING



- If the separator and/or the filter inside it are damaged, they should be replaced immediately.
- Observe the regulations in force in the country of use for the correct disposal of hazardous material, such as engine oil, diesel and engine coolant. Contact local authorities or a recycling centre.
- Never dispose of hazardous material irresponsibly by pouring it down drains, on the ground or into groundwater or waterways.
- Failure to observe these procedures could cause serious damage to the environment.

1. Close the fuel separator valve by turning it to OFF, (A2).
2. Remove the fuel filter (B) by turning it to the left.
3. Hold the filter firmly to prevent fuel from spilling out. In the event of spillages, clean the area affect thoroughly.
4. Clean the mounting surface of the filter and apply a small amount of diesel to the seal of the new fuel filter.
5. Install a new fuel filter, turning it to the right by hand so that it is contact with the assembly surface.
6. Tighten the new filter with a torque of $19,6 \div 23,5$ Nm.
7. Open the fuel separator valve by turning it to ON, (A1).
8. Prime the system by turning the ignition key to the "ON" position for 10 to 15 seconds in order to refill the bowl of the separator.
9. Check for leaks.

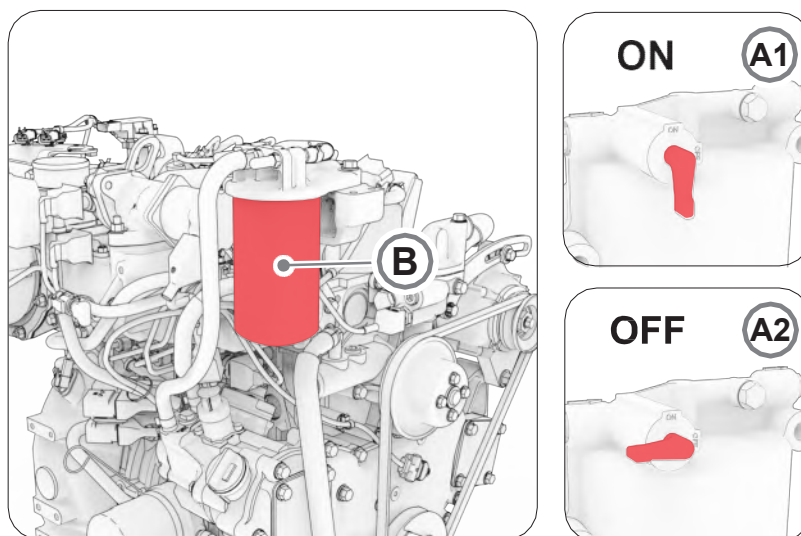

9.5.9 - CLEANING OR REPLACING AIR FILTERS

ATTENTION



- The filters should be cleaned *daily*.
- The cartridges of the air filter unit should be replaced *every 500 working hours*

DANGER



- Dismantle the air filter only when the engine is stopped and do not start the engine with the air filter open.
- During cleaning wear appropriate protective clothing.

ATTENTION



- Do not wash the air filter elements.
- Do not use solvents.
- Do not grease the cartridges.
- If cleaning with compressed air, take care how to direct the air jet to avoid damaging the filter cartridge. The air jet should always be directed from the inside of the cartridge outward. If you do the opposite, the filter will become ineffective and will release the dust into the extraction system when the engine is running, thus damaging the motor.

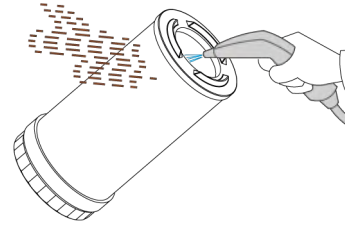

WARNING



- The air filter group consists of a primary high-capacity cartridge and a safety cartridge.
- The primary cartridge can be cleaned with a jet of air, but the safety cartridge must only be replaced.
- Each time the primary cartridge is replaced, the safety cartridge must be replaced too.

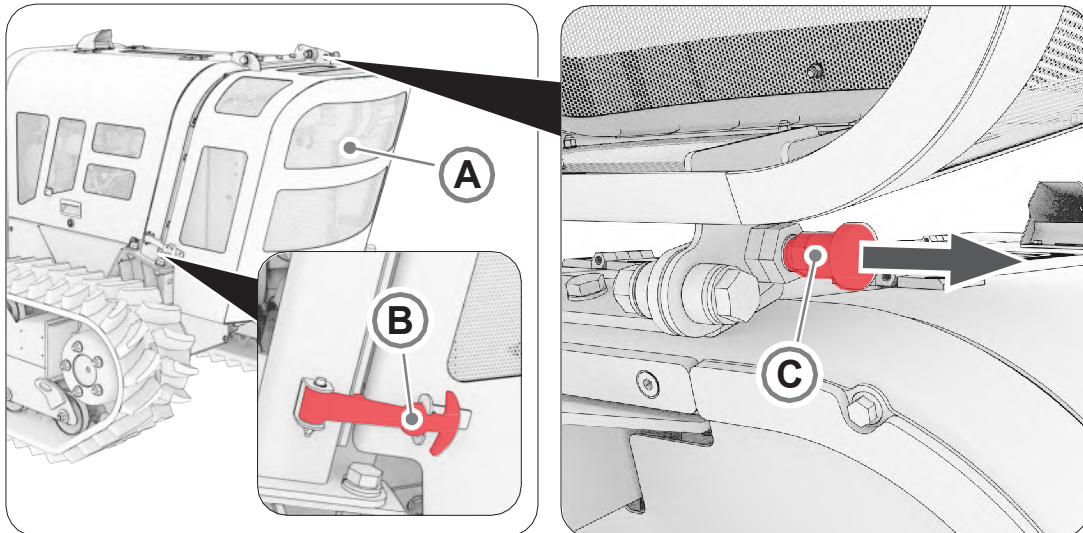

To clean/replace the air filter unit cartridge:

1. Detach the two rubber stay rods (B) securing the bonnet (A).
2. Pull the locking pin (C), raise the bonnet, then block it by releasing the pin.

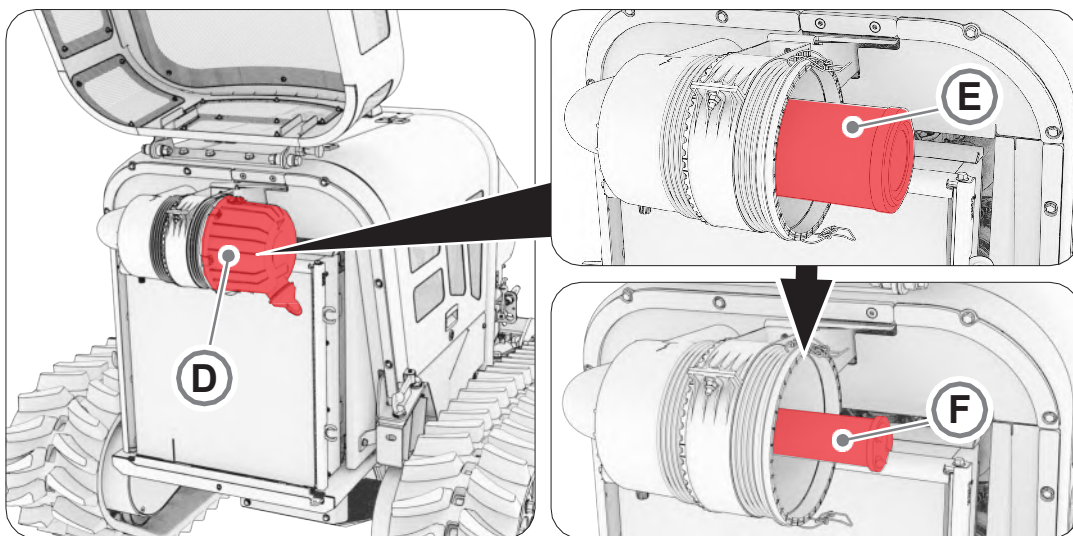

3. Release the two catches and remove the cover (D).
4. Pull the primary cartridge (E) out. If it is difficult to remove, turn the cartridge slightly whilst pulling it at the same time. Clean it with a jet of air or replace it.
5. Pull the safety cartridge (F). If the extraction of the cartridge is difficult, make small rotation movements and at the same time pull the cartridge. Replace the safety cartridge every time the primary cartridge is changed.
6. Put the cover back on and fasten it with the two catches.

9.5.10 - CLEANING THE RADIATOR CASING AND THE RADIATOR

ATTENTION



Cleaning of the radiator casing and the radiator should be done *daily* or every *8 working hours*.

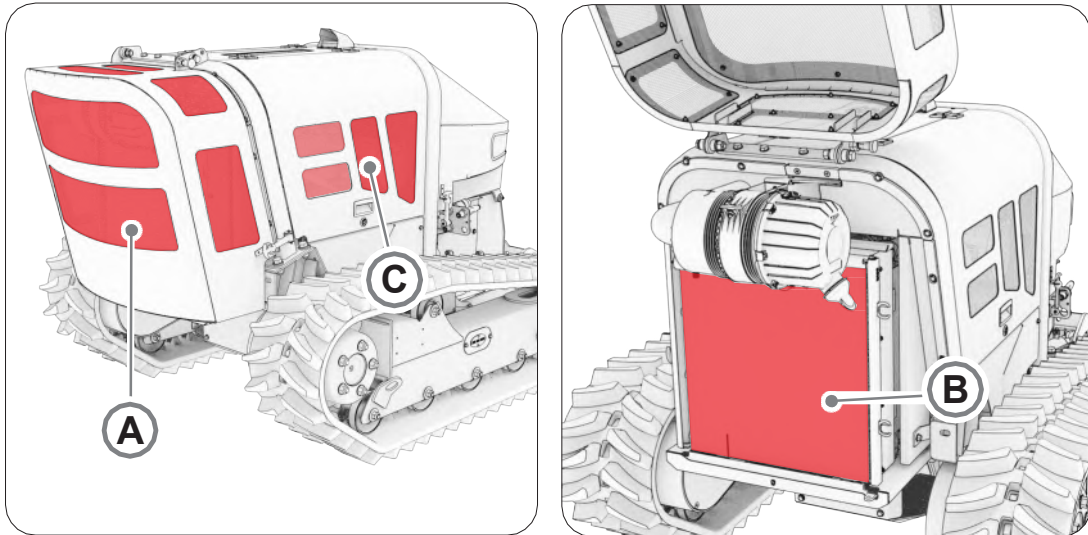

The radiator casing (A) should be cleaned both internally and externally. Clean with a jet of compressed air or with special products following the instructions on the containers of the products. Having completed the operations, dry the washed parts.

To increase the efficiency of the cooling system, in addition to cleaning via the reversible fan (section 6.3.19), it is advisable to remove any traces of dust from the radiator.

To clean the radiator, lift the radiator casing (A) and clean the outside of the radiator (B) with a jet of compressed air or with specific products, following the instructions indicated on the product packaging. Having completed the operations, dry the washed parts. Close the radiator casing (A).

Clean the grilles (C) on both sides.

The sensor installed on the engine that detects the coolant temperature has three trigger thresholds:

1. At 95°C, the RC40/T400 emits an audible warning and an alarm on the display;
2. At 100°C, the hydraulic motor of the equipment on the RC40/T400 is halted;
3. At 105°C, the RC40/T400 engine is shut down.

WARNING



If the engine temperature exceeds the maximum limit, the relative symbol appears on the display and the hydraulic motor of the tool is disabled.

9.6 - HYDRAULIC SYSTEM MAINTENANCE

9.6.1 - HYDRAULIC OIL LEVEL CHECK

ATTENTION

Check the hydraulic oil level *every 8 working hours or daily*.

WARNING

- Do not top up oil beyond the MAX level, this could cause oil to leak from the tank.
- Restore the level only using the hydraulic oil shown in the table (see 9.4.1).
- When using biodegradable oil Panolin HLP Synth E, avoid mixing it with other oils.
- The use of non-recommended lubricants and/or greases will result in invalidity of the warranty.

DANGER

When topping up, wear protective clothing.

The hydraulic oil check must be done on the flat.

The hydraulic oil level is correct when it reaches the mark on the dipstick attached to the filler cap.

To check the oil level:

1. Unscrew the cap (A) and check the oil level on it.
2. If the level of oil is low, top it up until it reaches the mark.
3. Close the cap tightly.

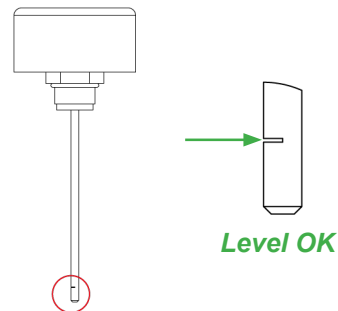
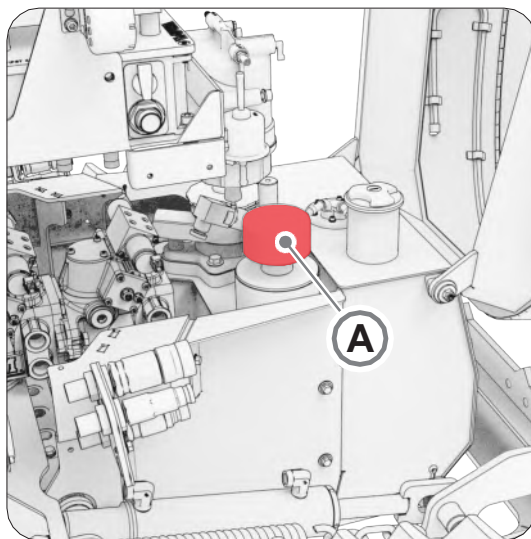

9.6.2 - CHANGING THE HYDRAULIC OIL FILTER

ATTENTION



- The hydraulic oil should be replaced as follows:

Type	Supplier	Replacement within
Mineral	Q8 HELLER 46	1000 hours
Biodegradable	PANOLIN HLP SYNTH E 46	15000 hours

- Quantity required for filling: 20 litres (approx.)**

DANGER



- It should be replaced with the machine is switched off, the equipment resting on the ground and when the hydraulic oil is cold.
- The machine should be parked on firm ground on the flat to ensure that the operations are carried out safely.

ATTENTION



- Always change the oil with the same type that was removed.
- Do not mix different types of oil.

To ensure correct lubrication and viscosity in the hydraulic pumps, it is necessary to replace the hydraulic oil at regular intervals. Refer to the following table for the frequency and type of oil to be used.

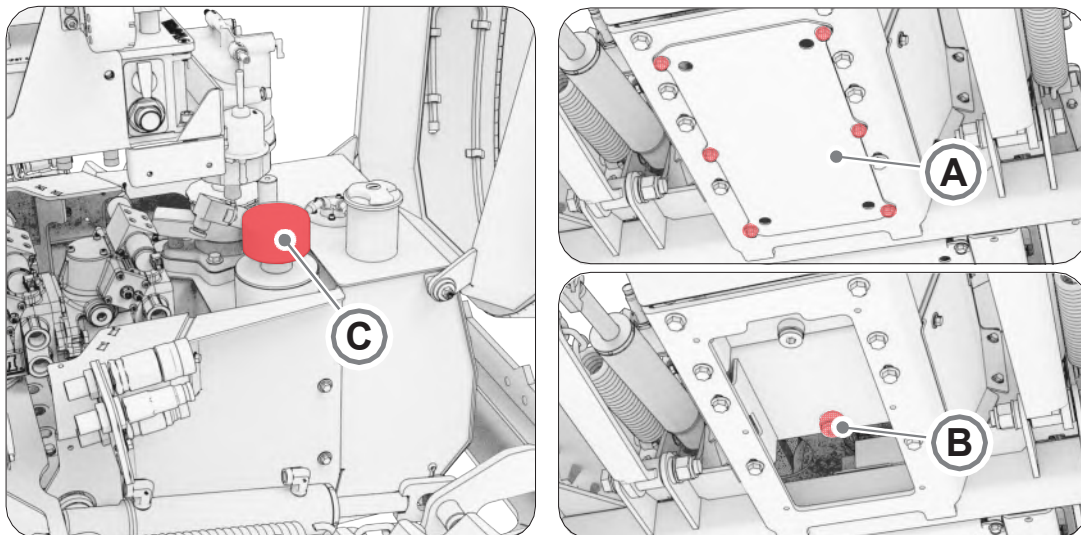

To change the oil proceed as follows:

- Stop the machine on a level surface and raised off the ground in order to be able to carry out the operations safely.
- Remove the front bottom guard (A) by unscrewing the six screws. It is recommended to clean all the parts thoroughly before draining the oil from the tank.
- Open the filler cap of the tank (C);
- Remove the drain plug (B) from the tank using a 10mm Allen key, being careful to collect the used oil in a container that has a capacity of at least thirty litres.

5. Tighten the cap (B) at the end of the operation and replace the copper washer, if necessary.
6. Add new hydraulic oil; refer the table above for the choice of oil.
7. Check the level on the dipstick attached to the filler cap (C).
8. As soon as the correct oil level has been reached (see section 9.6.1), start the engine and let it run for ten seconds, repeat this operation until the supercharging pressure is reached on the pumps (20÷22 bar).
9. Turn the engine off again and recheck the oil level.
10. If necessary, top up the oil pressure until the relative level lies between maximum and minimum.

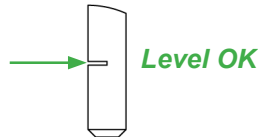

9.6.3 - CHANGING THE HYDRAULIC OIL FILTER

ATTENTION



The hydraulic oil filter should be replaced every 250 working hours or when the clogging indicator light (A) is displayed.

To replace it, perform the following operations:

- Unscrew the cap (B) using a 32mm spanner.
- Extract the filtering element (C);
- Filters should only be replaced with original filters and before they become completely clogged.
- Always check the O-ring and seals when a component of the hydraulic circuit is dismantled or is replaced. If broken or damaged, replace them.
- Close the cap again and tighten it with the spanner with a maximum torque of 20 Nm.

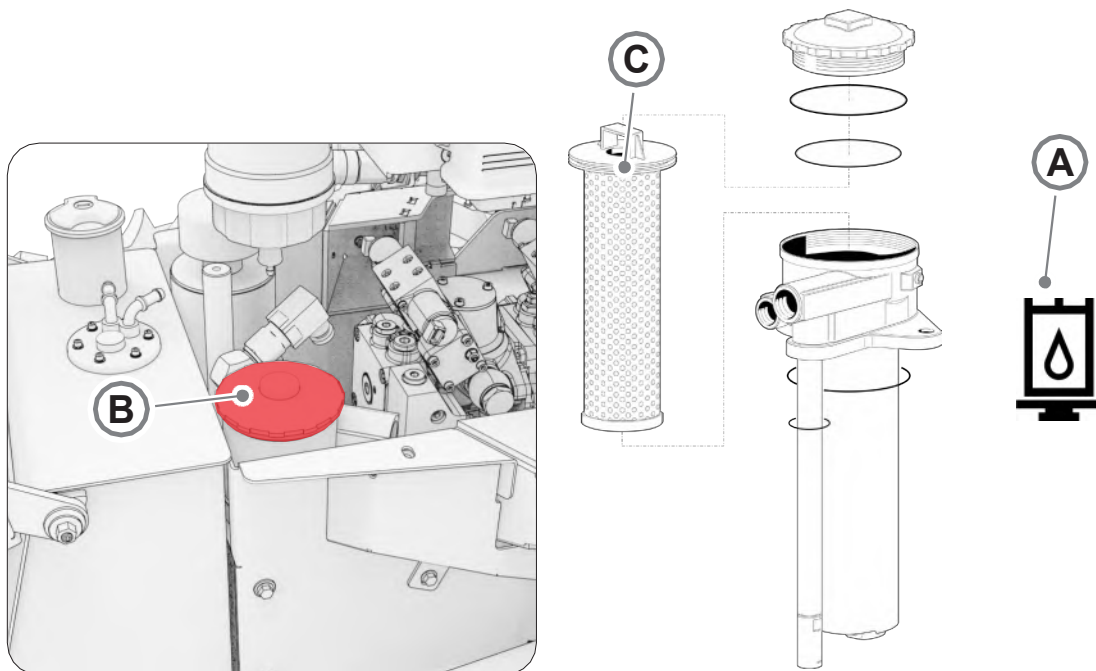

9.7 - MAINTENANCE OF THE HYDRAULIC MOTORS AND HYDRAULIC VALVES

Periodically check that:

- There are hydraulic motor and hydraulic oil leaks. If there are try tightening the fixing screws.
- The hydraulic fittings connected to the motor and valves are not loose. If they are, tighten them.
- If the problem persists, contact the McConnel Support Service.

DANGER



- **At operating temperature, the hydraulic oil is boiling and at times also pressurised.**
- **Avoid skin contact with the boiling oil and with its pipelines.**

9.8 - CHECKING AND MAINTAINING THE ELECTRICAL SYSTEM

ATTENTION



- **The electrical system should be checked every 250 working hours.**
- **If the cables show signs of a short circuit, look for the causes and contact the McConnel Service Department**

This is a visual inspection that must be carried out with the utmost care in order to avoid short-circuits in the system that would damage the machine. Check specifically:

- Fuses, if corroded or rusty, replace them with fuses of the same capacity.
- Batteries (**B**), check the battery clamp connections. If they are oxidised, remove the oxidation and coat them with appropriate grease. When carrying out this operation, be very careful not to let the earth wire (black) touch the power supply wire (red).
- Starter engine, check the cables.
- Alternator, check the cables.
- Check the tightness of connectors.

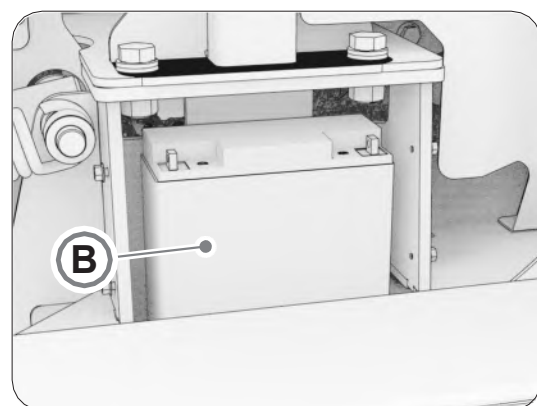
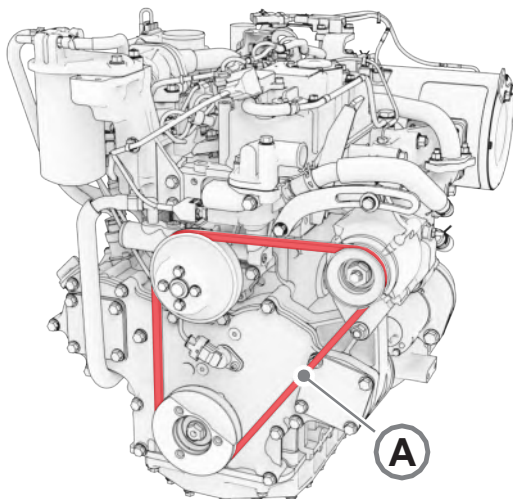

Maintenance interventions of the electrical system are:

- Checking the tension of the timing belt (**A**).
- Checking the battery charge (**B**).

9.8.1 - V-BELT INSPECTION/TENSIONING

To check the tension of the timing belt, proceed as follows:

1. Switch the machine off.
2. Open the right-hand bonnet with the relevant spanner supplied with the machine.
3. Check the belt tension (**A**): press the belt with a force of 98 Nm in one of the points indicated (**X**) or (**Y**);

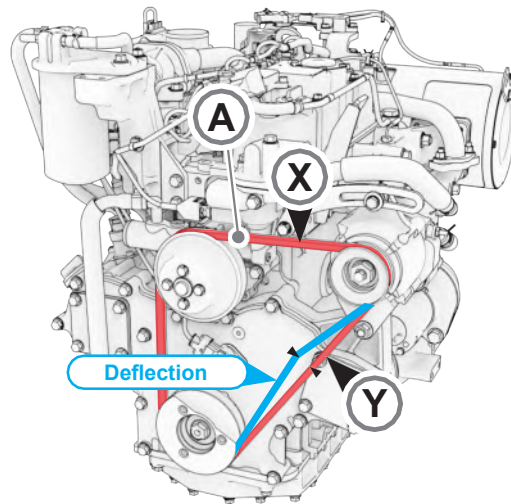

The correct deflection at each position is:

Tension of USED belt		
Position	X	Y
Displacement (mm)	7-10	10-14

“Used belt” refers to a belt that has been used with the engine running for 10 minutes or more.

4. If the belt tension is correct, skip to step 8 of the following section; if not, move onto the next step;
5. Loosen the adjustment screws (**B**) using a 12-mm spanner;
6. Use a lever to move the alternator and then tension the belt;
7. Screw up and tighten the screws (**B**) with a 23 Nm torque,
8. Close the right-hand bonnet.

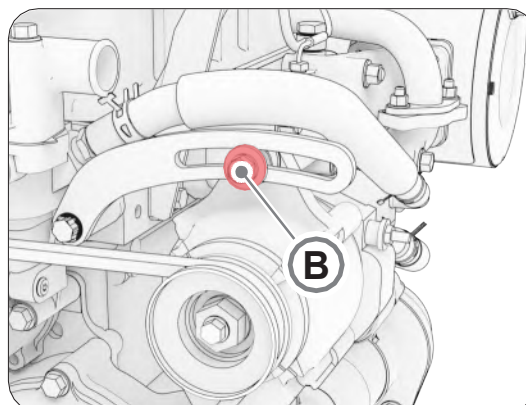

9.8.2 - REPLACING THE V-BELT

To replace the timing belt, proceed as follows:

1. Switch the machine off.
2. Open the right-hand bonnet with the relevant spanner supplied with the machine.
3. Loosen the adjustment screws (**B**) using a 12mm spanner;

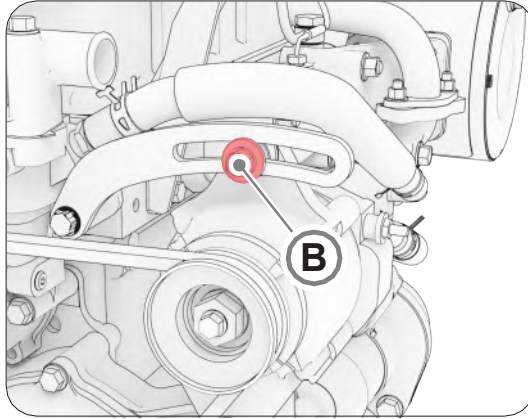

4. Remove the old belt by passing it between the reversible fan blades and the radiator shroud;
5. Insert the new belt by passing it between the reversible fan blades and the radiator shroud. Place the belt onto the three pulleys;
6. Use a lever to move the alternator in order to tension the belt;
7. Screw up and tighten the screws (**B**) with a 23 Nm torque,
8. Check the belt tension (**A**): press the belt with a force of 98 Nm in one of the points indicated (**X**) or (**Y**);

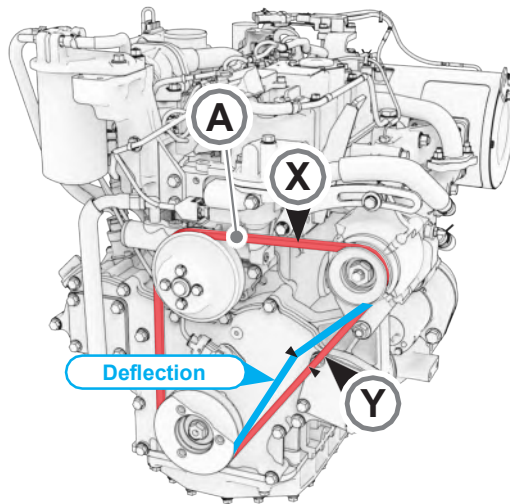

The correct deflection of the new belt at each position is:

Tension of NEW belt		
Position	X	Y
Displacement (mm)	5-8	8-12

9. Turn the engine on for about 10 minutes and then switch it off;

10. Check the tension again against the specifications for a “used” belt. See the following table:

Tension of USED belt		
Position	X	Y
Displacement (mm)	7-10	10-14

“Used belt” refers to a belt that has been used with the engine running for 10 minutes or more.

If, during the inspection you notice that:

- there is not enough distance between the belt and the lower section of the pulley groove (see diagrams below).
- the belt is cracked / split.
- the belt is oily.

If any of these conditions exist, replace the belt.

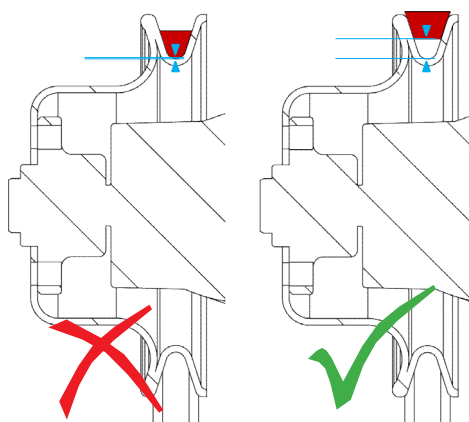

9.8.3 - CHECKING THE BATTERY CHARGE

To check the charge of the batteries:

1. Turn the machine off;
2. Open the front bonnet of the RC40/T400;
3. On the right-hand side of the RC40/T400, locate the junction box (A) of the positive lead which arrives directly from the battery (B);
4. Check the voltage of the battery using a multimeter (tester) by connecting the red test lead to the positive lead (B) and the black test lead to the machine ground (e.g. to the frame or the engine of the machine).

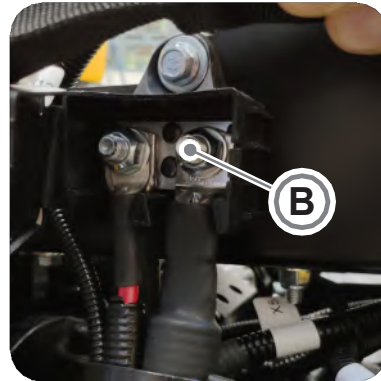
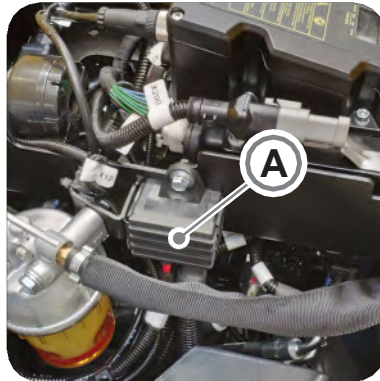

ATTENTION



If the voltage of the batteries with the engine switched off is sufficient (at least 12 - 12.5 Volts), but the machine does not start, DO NOT CONTINUE and proceed as indicated below.

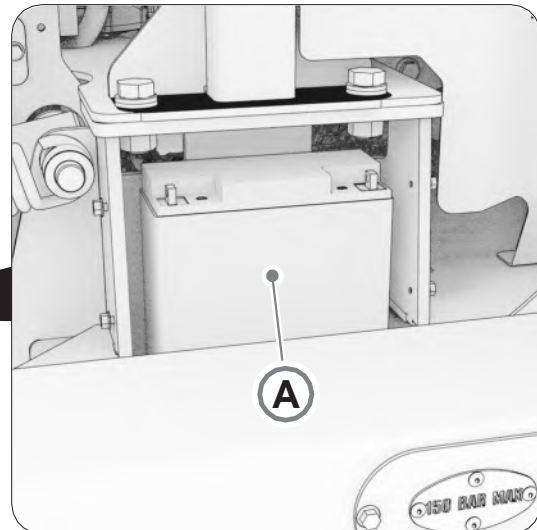
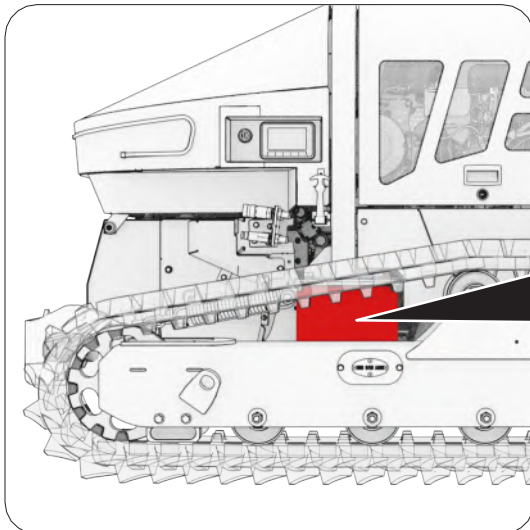

5. Loosen the four screws which secure the battery cover.
6. Remove the battery (A);
7. Repeat steps 5 and 6 for the battery on the other side.
8. Check the voltage of each battery using a multimeter (tester) by connecting the red test lead to the positive terminal and the black test lead to the negative terminal. If either or both batteries are discharged, recharge them. If the RC40/T400 has difficulty starting after charging the batteries, replace them.
9. Insert the new batteries.
10. Assemble the covers, then tighten the four screws.

Furthermore, make sure that:

- Do not carry out any modifications to the electrical system without the prior authorisation of McConnel.
- Do not eliminate or install any components without the prior authorisation of McConnel.
- Prevent the electrical system from coming into contact with water.
- Protect the connection pins with corrosion inhibitors.

DANGER

- **Never check the battery charge status by connecting the two poles with a metal object, use the voltmeter.**
- **Always disconnect the earth connector (—) of the battery first and reconnect it last.**
- **The sulphuric acid in the battery electrolyte is poisonous. It can cause burns to the skin get through fabrics and cause blindness if it comes into contact with the eyes.**
- **It should be noted that its compounds cause cancer and other harm to the reproductive organs. These substances are present in the battery poles, terminals and relative accessories. Wash your hands after touching them.**

9.9 - PERIODICAL REPLACEMENT OF THE SAFETY COMPONENTS

To guarantee safety at all times while the machine is being used, the operator is required to replace the components listed below:

Component	Years	Hours
Fuel pipes	2	2000
Hydraulic pipes	4	4000

9.10 - WHEEL DRIVE MAINTENANCE

9.10.1 - CHECKING THE TIGHTNESS OF THE SCREWS

ATTENTION

The screws should be tightened every *250 working hours*.

The check must be carried out using a torque wrench. Refer to the table below for the required tightening torques. This should be carried out on both sides of the machine.

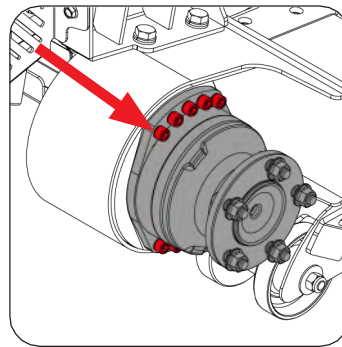
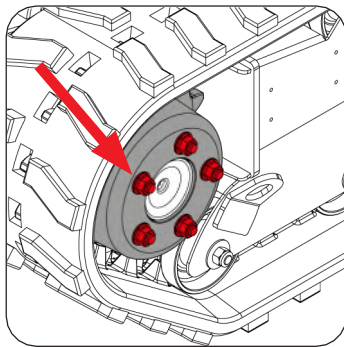

Nut size	M14
Spanner	21 mm
Tightening torque	250 ± 25 Nm

Screw size	M12
Allen key	10 mm
Tightening torque	79 Nm

9.11 - TRACK MAINTENANCE

9.11.1 - CHECKING THE TRACK TENSION PRESSURE

ATTENTION



The belt should be tensioned *every 50 working hours*.

DANGER



- The pressure test must be carried out with the utmost care because it is performed in a zone in which there can be a very high pressure.
- **NEVER WORK DIRECTLY ON THE VALVE WITH YOUR HANDS. IF THE VALVE IS BLOCKED OR DAMAGED, CONTACT AN McConnel SERVICE CENTRE.**
- Do not attempt to unblock the valve. Extremely dangerous pressures may have built up inside the valve.

ATTENTION



It is also recommended to recheck the tensioning after 8 / 10 hours of operation and set it to the values indicated in the table above.

This check should be carried out to preserve the tracks, keep them in perfect working order and to prevent the tracks from accidentally slipping out of position.

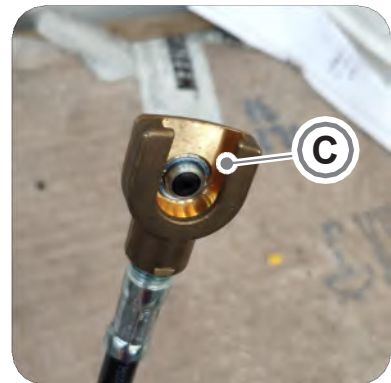
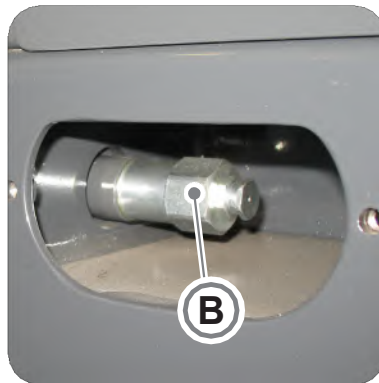

To check the pressure:

1. Position the machine on a level surface;
2. Remove cover (A);
3. Place the nozzle of the pump (C) onto the grease valve (B); check the pressure on the pressure gauge when injecting grease. Refer to the following table for the pressures of the tracks.
4. Replace the cover (A).

Track tightening pressure	
Track	Max. pressure (bar)
Rubber 250	150
Rubber 280	150

Use a lever grease gun having the following characteristics to tension the track:

Filling capacity	500 cm ³
Filling type	400 g (cartridge)
Delivery / stroke volume	1.2 cm ³
Delivery pressure (max)	400 bar
System pressure (max)	850 bar
Gauge pressure (max)	250 bar



9.11.2 - REPLACING THE TRACK

DANGER



- The machine support must be capable of supporting the load and keep it in a stable and safe position.
- To lift the machine, refer to chapter 7.

ATTENTION



It is also recommended to recheck the tensioning after 8 / 10 hours of operation and set it to the values indicated in the table above.

Tracks should be replaced when only 10 mm of tread is left, or before if they show signs of cuts.

Proceed as follows:

1. Place the machine on level ground with the engine switched off and raised (30 - 40 cm) off the ground.
2. Thoroughly clean the parts of the undercarriage.
3. Remove the cover (A) from the side member.
4. Slowly loosen the tensioning valve (B) using a 27 mm wrench in order to drain the grease.
5. Remove the tensioning valve only when there is no longer any pressure and the track is completely loose.
6. Move the front wheel backwards using a rubber hammer.
7. Lift the lower half of the track.
8. Move the track out from its seat (outwards) by levering it off from the idle wheel.
9. To install the new track follow the instructions above in reverse order.
10. The correct track tension is obtained by using the tensioning kit and injecting grease until the maximum pressure is reached (see section 9.11.1).

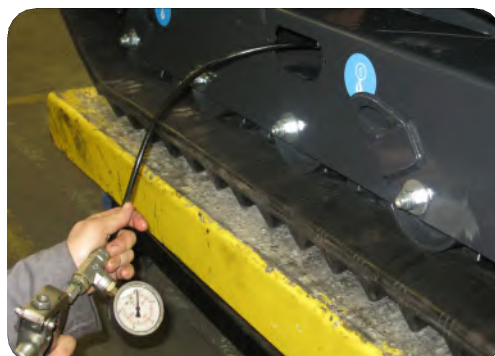
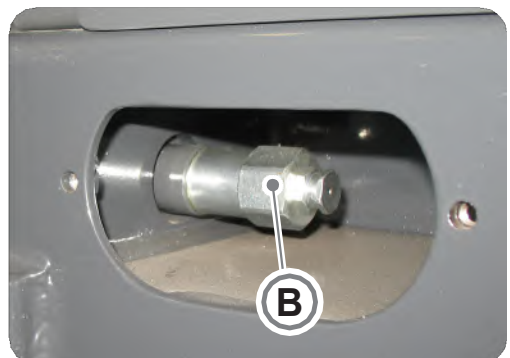

9.11.3 - ROLLER WEAR

The rollers are considered wear parts. Their duration depends on the ground on which they operate (muddy, sandy or other types).

An average life of 500 working hours is estimated, which obviously depends on the working conditions in which the machine is used.

It is recommended that you check a roller (by removing it) as soon as you realise that it doesn't rotate freely and establish the reason for it.

9.12 - GREASING THE LIFTING DEVICE

ATTENTION



The lifting device should be greased *every 50 working hours or weekly*.

All moving parts of the RC40/T400 that need to be greased are fitted with grease nipples.

To grease the machine you must:

1. have an appropriate pump.
2. Connect the nozzle of the grease gun to the grease nipple on the machine.
3. Pump in grease into it until a small amount seeps out from the joints.
4. Repeat the entire procedure for the other side as well.

Refer to the grease table in section 9.4.1 for what grease to choose. Proper lubrication is very important. Insufficient and infrequent lubrication may cause premature faults or overheating in some of the working parts as well as damage to the gaskets.

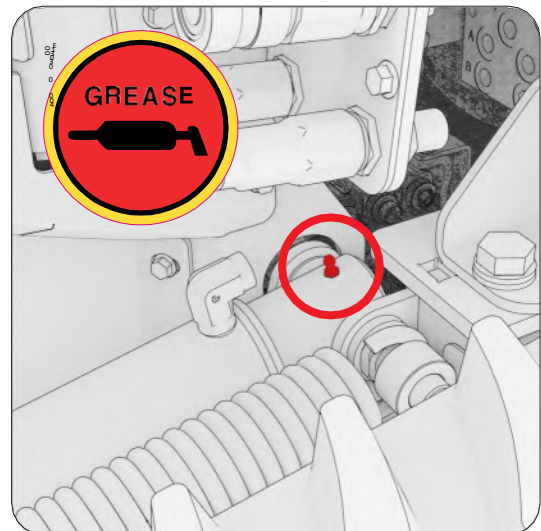

9.12.1 - CHECKING THE CHROME-PLATED PARTS

ATTENTION



Inspect the chrome-plated parts of the machine (cylinders) and make sure that they are not scored or damaged - *every 50 working hours or weekly*.

9.13 - MAINTENANCE OPERATIONS

9.13.1 - MAINTENANCE FREQUENCY

		Every 8 hours / daily	Every 50 hours / weekly	50 hours	250 hours	500 hours	750 hours	1000 hours	1250 hours	1500 hours	1750 hours	2000 hours	2250 hours	2500 hours	2750 hours	3000 hours
ENGINE OIL	Check / Top up	X														
	Replacement			X	X	X	X	X	X	X	X	X	X	X	X	X
ENGINE OIL FILTER	Replacement			X	X	X	X	X	X	X	X	X	X	X	X	X
LIQUID COOLANT	Check / Top up	X														
	Replacement							X				X				X
FUEL	Check / Top up	X														
FUEL FILTER	Replacement					X		X		X		X		X		X
FUEL SEPARATOR	Check / Drain		X													
FUEL SEPARATOR CARTRIDGE	Replacement					X		X		X		X		X		X
ENGINE AIR FILTER	Check / Clean	X														
	Replacement					X		X		X		X		X		X
ELECTRIC PLANT	Check					X	X	X	X	X	X	X	X	X	X	X
BATTERY	Check					X	X	X	X	X	X	X	X	X	X	X
BELT TENSIONING	Check					X	X	X	X	X	X	X	X	X	X	X
HYDRAULIC OIL	Check / Top up	X														
	Replacement							X^(a)				X^(a)				X^(a)
HYDRAULIC OIL FILTER	Replacement				X	X	X	X	X	X	X	X	X	X	X	X
RADIATOR CASING	Clean	X														
RADIATOR	Clean	X														
TENSIONING TRACKS	Check		X													
RETAINER MONOWHEEL	Check					X	X	X	X	X	X	X	X	X	X	X
LIFTING DEVICE	Greasing		X													
CHROME-PLATED PARTS	Check		X													

^(a) Change according to the type of hydraulic oil in the machine. (Refer to the tables in sections 9.4.1 and 9.6.2).

10 - INSTRUCTIONS FOR EMERGENCY SITUATIONS

10.1 - FIRE

In case of fire, use a fire extinguisher according to the standards in force. If the machine catches fire or it is close to a fire, raise the alarm and contact the fire service.

10.2 - ASSISTING THE OPERATOR IN CASE OF ILLNESS

If the operator feels unwell, you need to act quickly, following the steps indicated below:

- Get to the operator, if you are unable to do so safely, contact medical or first aid personnel.
- Lay the operator on the ground following first aid procedures.
- Contact a doctor or the emergency services if you have not already done so.

10.3 - MANUAL BRAKE RELEASE & TOWING

Parking Brake Release

During operation or transport, situations may arise when it may be necessary to tow the machine. Before attempting to tow the machine the parking brake must be manually released to reduce the possibility of damage to the drive motor, tracks, or braking systems, and provide safe towing.

The procedure of releasing the brakes requires access to the brake flange plate at the back of the drive motor and utilisation of the following items; a 12mm bolt, a 12mm nut and a support plate with a central hole. The method of release is described below;

⚠ WARNING

Ensure machines tracks are safely and securely 'chocked' before attempting to release the brakes.

Remove the 4 bolts which retain the cover to the drive motor housing to gain access to the brake assembly on the back of the drive motor.



Pry the rubber dust cover from the brake release access hole.



With nut and support plate on the 12mm bolt; thread the bolt into the manual brake release hole until it 'bottoms out' in the hole. Move the washer down the shank of the bolt and thread the nut down until it is in firm contact with the metal support plate. Tightening the nut will gradually draw the bolt out and pull the brake plates away releasing the brakes. Turn the nut until it tightens against the plate and will no longer turn. Stop when resistance prevents further movement, **do not over-tighten.**



10.4 - TOWING

⚠ CAUTION

Towing of the machine should only be performed in an emergency situation; it should be avoided whenever possible.

Manually release the braking system before attempting to tow the machine; see *previous page* for details of this procedure.

Suitable towing straps or chains rated to **minimum 2 tonne** and free from damage or defects must be used to tow the machine. Towing equipment should be configured as shown in the illustration opposite.

A. Towing strap/chain with minimum 2 tonne rating.

B. Rigid link device with minimum 2 tonne rating.

Attach the straps/chains to the lifting point positions on each side of the machine. Tow the machine maintaining even pull on each side in a forward direction. Avoid towing the machine from one side or the other as this can risk damaging the tracks and/or track components.

⚠ WARNING

When towing the machines on downward inclines suitable rigid towing equipment must be used.

⚠ WARNING

Care must be adopted at all times when towing the machine as there will be no form of braking. Chock tracks to avoid risk of 'freewheeling'. Keep all persons clear of the front and rear of the machine when parking brakes have been manually released.

⚠ WARNING

When towing or lifting the machine the correct attachment points must be used, failure to observe this may result in serious damage to machine and/or injury to persons.

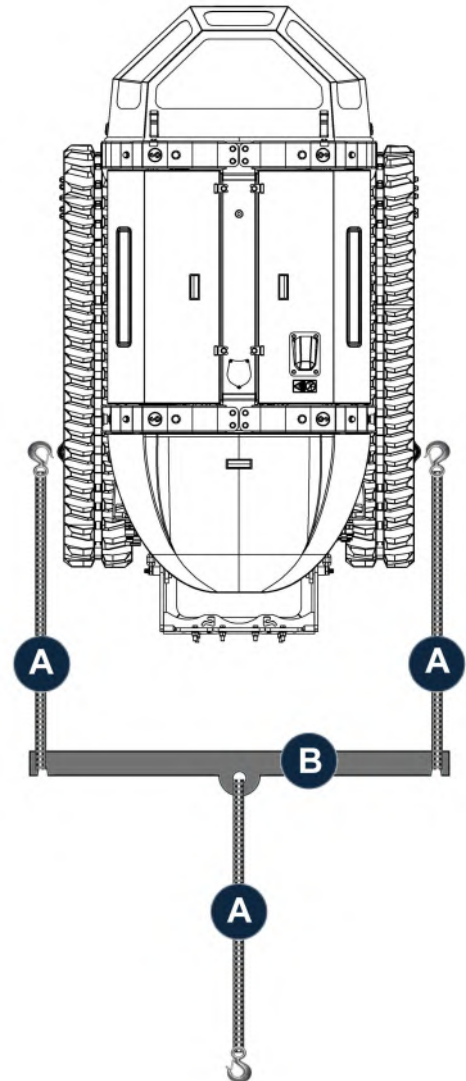

11 - TIGHTENING TABLES

11.1 - SCREW TIGHTENING TABLE

Threading nominal size	Actual section area as mm ²	Strength class								
		12.9			10.9			8.8		
		Breaking load	Initial tightening force	Tightening torque	Breaking load	Initial tightening force	Tightening torque	Breaking load	Initial tightening force	Tightening torque
		N	N	Nm	N	N	Nm	N	N	Nm
M 3×0.5	5.03	5523	3865	2	4728	3316	1	3218	2256	1
M 4×0.7	8.78	9643	6749	4	8260	5778	3	5621	3934	2
M 5×0.8	14.2	15597	10918	8	13361	9349	7	9094	6367	5
M 6×1	20.1	22082	15460	14	18914	13234	12	12881	9015	8
M 8×1.25	36.6	40211	28144	33	34433	24103	28	23446	16412	19
M 10×1.5	58	63725	44606	65	54563	38200	56	37150	26006	38
M 12×1.75	84.3	92626	64834	114	79304	55515	97	54004	37798	66
M 14×2	115	126352	88446	181	108194	75733	155	73673	51571	105
M 16×2	157	172499	118102	282	147699	103388	241	100572	70397	164
M 18×2.5	192	210954	147669	387	180632	126441	332	126765	88731	232
M 20×2.5	245	269186	18843	549	230496	161345	470	161757	113227	330
M 22×2.5	303	332912	233036	748	285059	199535	640	200046	140028	449
M 24×3	353	387848	271491	950	332098	232468	813	233056	163140	571

11.2 - FITTINGS TIGHTENING TABLE

Series	Ø Pipe	THREADING - TIGHTENING TORQUE					
		Ø Imperial thread	Shape B MT (Nm)	Shape E MT (Nm)	Ø Metric thread	B MT (Nm) shape	Shape E MT (Nm)
Light	6	G 1/8"	25	20	M 10 x 1	25	20
	8	G 1/4"	45	40	M 12 x 1.5	30	30
	10	G 1/4"	45	40	M 14 x 1.5	50	50
	12	G 3/8"	85	80	M 16 x 1.5	80	60
	15	G 1/2"	160	100	M 18 x 1.5	90	80
	18	G 1/2"	105	100	M 22 x 1.5	150	140
	22	G 3/4"	230	200	M 26 x 1.5	240	200
	28	G 1"	390	380	M 33 x 2	400	380
	35	G 1" 1/4	600	500	M 42 x 2	600	500
42	G 1" 1/2	800	600	M 48 x 2	800	600	
Strong	6	G 1/4"	60	60	M 12 x 1.5	45	45
	8	G 1/4"	60	60	M 14 x 1.5	60	60
	10	G 3/8"	110	90	M 16 x 1.5	95	80
	12	G 3/8"	110	90	M 18 x 1.5	120	100
	14	G 1/2"	170	130	M 20 x 1.5	170	140
	16	G 1/2"	140	130	M 22 x 1.5	190	150
	20	G 3/4"	320	200	M 27 x 2	320	200
	25	G 1"	390	380	M 33 x 2	450	380
	30	G 1" 1/4	600	500	M 42 x 2	600	500
38	G 1" 1/2	800	600	M 48 x 2	800	600	



McConnel Limited, Temeside Works, Ludlow, Shropshire SY8 1JL. England.
Telephone: 01584 873131. Facsimile: 01584 876463. www.mcconnel.com