

Publication 736
April 2013
Part No. 22675.36
Revised: 08.09.22



McCONEL

PA5054 VERSI

FRONT / REAR MOUNT DUAL DIRECTION
HEDGE CUTTER / GRASS MOWER

Operator Manual

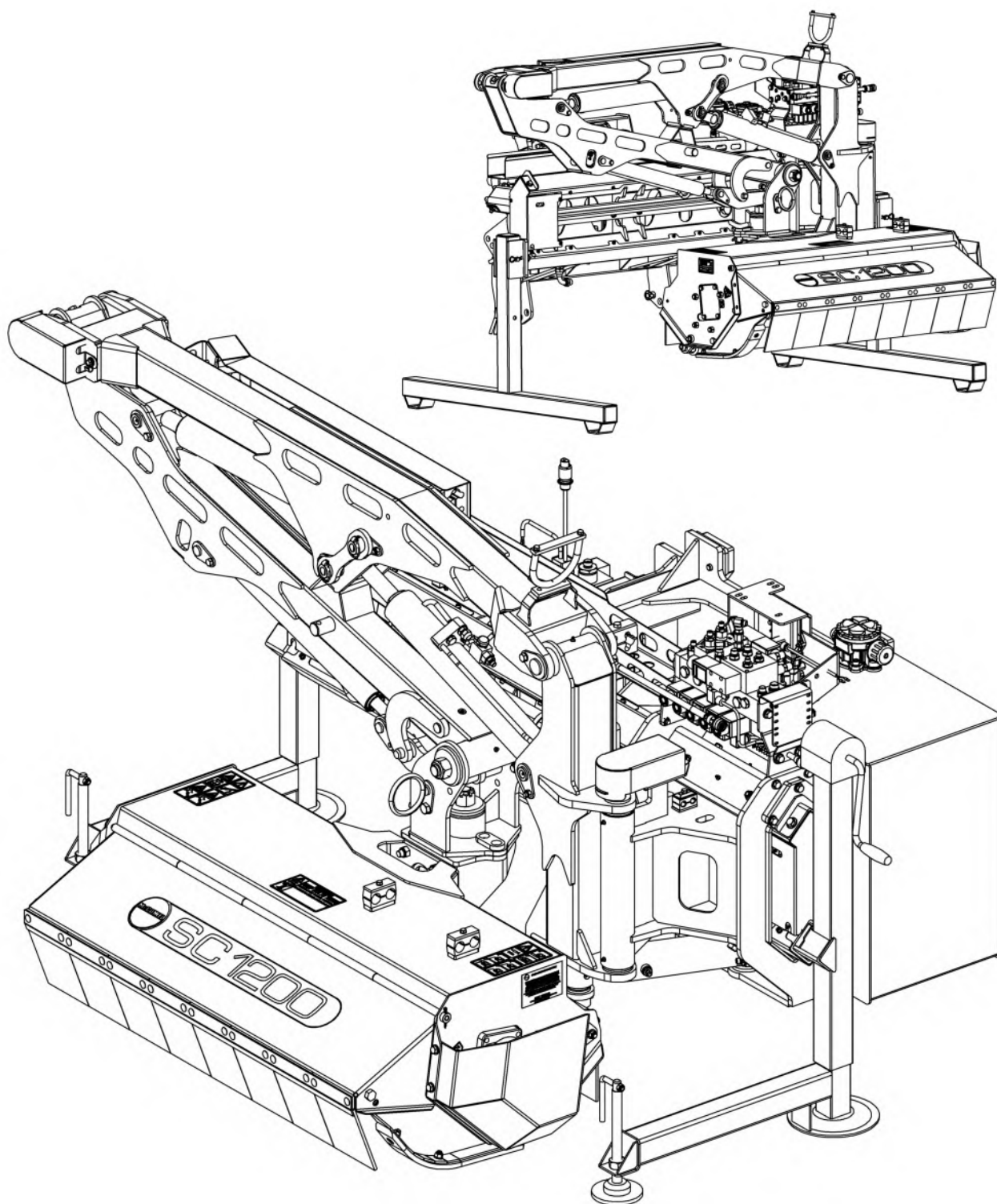

IMPORTANT

VERIFICATION OF WARRANTY REGISTRATION



Dealer Warranty Information & Registration Verification

It is imperative that the selling dealer registers this machine with McConnel Limited before delivery to the end user – failure to do so may affect the validity of the machine warranty.

To register machines; log onto <https://my.mcconnel.com> and select 'Machine Registration' which can be found in the 'Warranty' section of the site. **Confirm to the customer that the machine has been registered by completing the verification form below.**

| | |
|--|---------------------------------|
| Registration Verification | Serial No. <input type="text"/> |
| Dealer Name: | |
| Dealer Address: | |
| Customer Name: | |
| Date of Warranty Registration:/...../..... | Dealer Signature: |

Note to Customer / Owner

Please ensure the section above has been completed and signed by the dealer to verify your machine has been registered with McConnel Limited.

IMPORTANT: During the initial 'bedding in' period of a new machine it is the customer's responsibility to regularly inspect all nuts, bolts and hose connections for tightness and re-tighten if required. New hydraulic connections occasionally weep small amounts of oil as the seals and joints settle in – where this occurs it can be cured by re-tightening the connection – *refer to torque settings chart below*. The tasks stated above should be performed on an hourly basis during the first day of work and at least daily thereafter as part of the machine's general maintenance procedure.

CAUTION: DO NOT OVER TORQUE HYDRAULIC FITTINGS AND HOSES

Torque Settings for Hydraulic Fittings

| Hydraulic Hose Ends | | |
|---------------------|---------|--------|
| BSP | Setting | Metric |
| 1/4" | 18 Nm | 19 mm |
| 3/8" | 31 Nm | 22 mm |
| 1/2" | 49 Nm | 27 mm |
| 5/8" | 60 Nm | 30 mm |
| 3/4" | 80 Nm | 32 mm |
| 1" | 125 Nm | 41 mm |
| 1.1/4" | 190 Nm | 50 mm |
| 1.1/2" | 250 Nm | 55 mm |
| 2" | 420 Nm | 70 mm |

| Port Adaptors with Bonded Seals | | |
|---------------------------------|---------|--------|
| BSP | Setting | Metric |
| 1/4" | 34 Nm | 19 mm |
| 3/8" | 47 Nm | 22 mm |
| 1/2" | 102 Nm | 27 mm |
| 5/8" | 122 Nm | 30 mm |
| 3/4" | 149 Nm | 32 mm |
| 1" | 203 Nm | 41 mm |
| 1.1/4" | 305 Nm | 50 mm |
| 1.1/2" | 305 Nm | 55 mm |
| 2" | 400 Nm | 70 mm |

WARRANTY POLICY

WARRANTY REGISTRATION

All machines must be registered, by the selling dealer with McConnel Ltd, before delivery to the end user. On receipt of the goods it is the buyer's responsibility to check that the Verification of Warranty Registration in the Operator's Manual has been completed by the selling dealer.

1. LIMITED WARRANTIES

- 1.01. *All mounted machines supplied by McConnel Ltd are warranted to be free from defects in material and workmanship from the date of sale to the original purchaser for a period of 12 months, unless a different period is specified.
All Self Propelled Machines supplied by McConnel Ltd are warranted to be free from defects in material and workmanship from the date of sale to the original purchaser for a period of 12 months or 1500 hours. Engine warranty will be specific to the Manufacturer of that unit.*
- 1.02. *All spare parts supplied by McConnel Ltd and purchased by the end user are warranted to be free from defects in material and workmanship from the date of sale to the original purchaser for a period of 6 months. All parts warranty claims must be supported by a copy of the failed part invoice to the end user. We cannot consider claims for which sales invoices are not available.*
- 1.03. *The warranty offered by McConnel Ltd is limited to the making good by repair or replacement for the purchaser any part or parts found, upon examination at its factory, to be defective under normal use and service due to defects in material or workmanship. Returned parts must be complete and unexamined. Pack the component(s) carefully so that any transit damage is avoided. All ports on hydraulic items should be drained of oil and securely plugged to prevent seepage and foreign body ingress. Certain other components, electrical items for example, may require particular care when packing to avoid damage in transit.*
- 1.04. *This warranty does not extend to any product from which McConnel Ltd's serial number plate has been removed or altered.*
- 1.05. *The warranty policy is valid for machines registered in line with the terms and conditions detailed and on the basis that the machines do not extend a period of 24 months or greater since their original purchase date, that is the original invoice date from McConnel Limited.
Machines that are held in stock for more than 24 months cannot be registered for warranty.*
- 1.06. *This warranty does not apply to any part of the goods, which has been subjected to improper or abnormal use, negligence, alteration, modification, fitment of non-genuine parts, accident damage, or damage resulting from contact with overhead power lines, damage caused by foreign objects (e.g. stones, iron, material other than vegetation), failure due to lack of maintenance, use of incorrect oil or lubricants, contamination of the oil, or which has served its normal life. This warranty does not apply to any expendable items such as blades, belts, clutch linings, filter elements, flails, flap kits, skids, soil engaging parts, shields, guards, wear pads, pneumatic tyres or tracks.*
- 1.07. *Temporary repairs and consequential loss - i.e. oil, downtime and associated parts are specifically excluded from the warranty.*
- 1.08. *Warranty on hoses is limited to 12 months and does not include hoses which have suffered external damage. Only complete hoses may be returned under warranty, any which have been cut or repaired will be rejected.*
- 1.09. *Machines must be repaired immediately a problem arises. Continued use of the machine after a problem has occurred can result in further component failures, for which McConnel Ltd cannot be held liable, and may have safety implications.*
- 1.10. *If in exceptional circumstances a non McConnel Ltd part is used to effect a repair, warranty reimbursement will be at no more than McConnel Ltd's standard dealer cost for the genuine part.*
- 1.11. *Except as provided herein, no employee, agent, dealer or other person is authorised to give any warranties of any nature on behalf of McConnel Ltd.*

- 1.12. For machine warranty periods in excess of 12 months the following additional exclusions shall apply:
- 1.12.1. Hoses, exposed pipes and hydraulic tank breathers.
 - 1.12.2. Filters.
 - 1.12.3. Rubber mountings.
 - 1.12.4. External electric wiring.
 - 1.12.5. Bearings and seals
 - 1.12.6. External Cables, Linkages
 - 1.12.7. Loose/Corroded Connections, Light Units, LED's
 - 1.12.8. Comfort items such as Operator Seat, Ventilation, Audio Equipment
- 1.13. All service work, particularly filter changes, must be carried out in accordance with the manufacturer's service schedule. Failure to comply will invalidate the warranty. In the event of a claim, proof of the service work being carried out may be required.
- 1.14. Repeat or additional repairs resulting from incorrect diagnosis or poor quality previous repair work are excluded from warranty.

NB Warranty cover will be invalid if any non-genuine parts have been fitted or used. Use of non-genuine parts may seriously affect the machine's performance and safety. McConnel Ltd cannot be held responsible for any failures or safety implications that arise due to the use of non-genuine parts.

2. REMEDIES AND PROCEDURES

- 2.01. The warranty is not effective unless the Selling Dealer registers the machine, via the McConnel web site and confirms the registration to the purchaser by completing the confirmation form in the operator's manual.
- 2.02. Any fault must be reported to an authorised McConnel Ltd dealer as soon as it occurs. Continued use of a machine, after a fault has occurred, can result in further component failure for which McConnel Ltd cannot be held liable.
- 2.03. Repairs should be undertaken within two days of the failure. Claims submitted for repairs undertaken more than 2 weeks after a failure has occurred, or 2 days after the parts were supplied will be rejected, unless the delay has been authorised by McConnel Ltd. Please note that failure by the customer to release the machine for repair will not be accepted as a reason for delay in repair or submitting warranty claims.
- 2.04. All claims must be submitted, by an authorised McConnel Ltd Service Dealer, within 30 days of the date of repair.
- 2.05. Following examination of the claim and parts, McConnel Ltd will pay, at their discretion, for any valid claim the invoiced cost of any parts supplied by McConnel Ltd and appropriate labour and mileage allowances if applicable.
- 2.06. The submission of a claim is not a guarantee of payment.
- 2.07. Any decision reached by McConnel Ltd. is final.

3. LIMITATION OF LIABILITY

- 3.01. McConnel Ltd disclaims any express (except as set forth herein) and implied warranties with respect to the goods including, but not limited to, merchantability and fitness for a particular purpose.
- 3.02. McConnel Ltd makes no warranty as to the design, capability, capacity or suitability for use of the goods.
- 3.03. Except as provided herein, McConnel Ltd shall have no liability or responsibility to the purchaser or any other person or entity with respect to any liability, loss, or damage caused or alleged to be caused directly or indirectly by the goods including, but not limited to, any In direct, special, consequential, or incidental damages resulting from the use or operation of the goods or any breach of this warranty. Notwithstanding the above limitations and warranties, the manufacturer's liability hereunder for damages incurred by the purchaser or others shall not exceed the price of the goods.
- 3.04. No action arising out of any claimed breach of this warranty or transactions under this warranty may be brought more than one (1) year after the cause of the action has occurred.

4. MISCELLANEOUS

- 4.01. McConnel Ltd may waive compliance with any of the terms of this limited warranty, but no waiver of any terms shall be deemed to be a waiver of any other term.*
- 4.02. If any provision of this limited warranty shall violate any applicable law and is held to be unenforceable, then the invalidity of such provision shall not invalidate any other provisions herein.*
- 4.03. Applicable law may provide rights and benefits to the purchaser in addition to those provided herein.*

McConnel Limited

POWER ARM & TRACTOR PRE-OPERATION INSPECTION

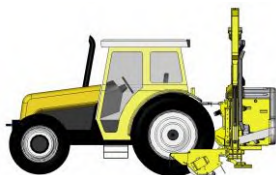

A daily equipment inspection of machine and tractor should be conducted before the equipment is used.

Use the inspection sheets on the following pages to assist with these daily inspections. Damaged or missing guards should be repaired or replaced before operating the mower. Failure to repair or replace damaged guards can result in objects being thrown from the mower and possibly hitting the operator and/or bystanders.

Inspect the Mower for Safe Operating Condition

- Make sure the driveline guards and shielding are in place and in good repair.
- Inspect the flexible thrown object shielding to assure that they are in place on the front and rear of the mower head and in good repair. Repair or replace any damaged or missing thrown object shields.
- Ensure the mower cutting height is set high enough to reduce the possibility of the mower blades contacting the ground. Actual height will be dependent on the ground conditions. Increase the height when working in rough or undulating conditions.
- Inspect for broken, chipped, bent, missing, or severely worn blades. Replace damaged blades before operating the mower. Ensure the blade retaining bolts and fasteners are secure and tight.
- Ensure all head bolts and nuts are tight.
- Lubricate the driveline universal joints and telescoping members daily.
- Grease the rotor and roller bearings and inspect their condition.
- Inspect for any oil leaks or damaged hoses.
- Inspect for worn and/or damaged decals and safety instructions. Replace unreadable, damaged or missing safety decals.
- Follow the operator's manual(s) inspection and maintenance instructions for lubricating parts, and keeping thrown object shielding, driveline guards, rotating parts shields, mower blades, and decals in good repair.

Inspect the Tractor for Safe Operating Condition

- Inspect the controls, lights, SMV's (Slow Moving Vehicle sign), seat belts, and ROPS to ensure they are in place and in good working order.
- Ensure tyres, wheels, lug bolts/nuts are in good condition.
- Make sure the tractor brakes and steering are in proper operating condition.
- Follow the operator's manual(s) inspection and maintenance procedures for keeping the tractor in good and safe condition before operating.

Copies of the inspection sheets on the following pages should be retained in this manual for reference; two sets are included to allow removal of one set for photocopying purposes. Alternatively, these inspection sheets can be download from our website via the QR code or using the link below;
<https://my.mcconnel.com/service/pre-operation-inspection-documents/>





POWER ARM PRE-OPERATION INSPECTION



Power Arm ID Date: Shift:



WARNING: Before conducting the inspection, make sure the tractor engine is off, the key removed, all rotation has stopped and the tractor is in park with the parking brake engaged. Make sure the mower head is resting on the ground or is securely blocked up and supported and all hydraulic pressure has been relieved.

| Item | Condition at start of shift | Specific Comments if not O.K. |
|--|-----------------------------|-------------------------------|
| The operator's manual is in the canister on the mower. | | |
| All warning decals are in place, clean and legible. | | |
| All lights are clean and working. | | |
| The mounting frame bolts are in place and tight. | | |
| The arm pivot pins are tight and correctly secured. | | |
| There are no cracks in the arms. | | |
| Hydraulic cylinder pins are tight and correctly secured. | | |
| Hydraulic cylinder hose connections are tight. | | |
| Hydraulic pump hose connections are tight. | | |
| Hydraulic valve hose connections are tight. | | |
| Hydraulic valve controls function properly. | | |
| There are no damaged hoses. | | |
| The oil level is to the green mark on the tank sight glass. | | |
| There is no evidence of hydraulic oil leaks. | | |
| Flails are not missing, chipped, broken or excessively worn. | | |
| The flail bolts are tight. | | |
| The front and rear flaps are fitted and in good condition. | | |
| The front hood is in place and in good condition. | | |
| The wire trap is in good condition. | | |
| The skid shoes are in good condition and tight. | | |
| There are no cracks or holes in flail casing. | | |
| Hydraulic motor mounting bolts are tight. | | |
| All flail head nuts and bolts are tight. | | |
| The rotor bearings are in good condition and greased. | | |
| The roller bearings are in good condition and greased. | | |
| The drive line shaft guard is in good condition. | | |
| The drive line shaft guard is correctly secured. | | |
| Controls are securely mounted in the cab. | | |
| With engine running check arm operation. | | |
| Have a spare pack of flails, bushes, bolts and nuts. | | |

Operators Signature:

DO NOT OPERATE AN UNSAFE TRACTOR OR MACHINE



TRACTOR PRE-OPERATION INSPECTION

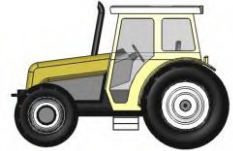

Power Arm ID Date: Shift:



WARNING: Before conducting the inspection, make sure the tractor engine is off, the key removed, all rotation has stopped and the tractor is in park with the parking brake engaged. Ensure any implement attached to the tractor is firmly on the ground.

| Item | Condition at start of shift | Specific Comments if not O.K. |
|---|-----------------------------|-------------------------------|
| The flashing lights function properly. | | |
| All lights are clean and working correctly. | | |
| All cab windows are clean and wipers working correctly. | | |
| The SMV sign, where required, is clean and visible. | | |
| The tyres are in good condition with correct pressure. | | |
| The wheel nuts are tight. | | |
| The tractor brakes are in good condition. | | |
| The steering linkage is in good condition. | | |
| There are no visible oil leaks. | | |
| The hydraulic controls function properly. | | |
| The ROPS or ROPS cab is in good condition. | | |
| The seatbelt is in place and in good condition. | | |
| The 3-point hitch is in good condition. | | |
| The drawbar/pick up hook is secure and in good condition. | | |
| The PTO master shield is in place. | | |
| The engine oil level is full. | | |
| The brake fluid level is full. | | |
| The power steering fluid level is full. | | |
| The fuel level is adequate. | | |
| The engine coolant fluid level is full. | | |
| The radiator and oil cooler are free of debris. | | |
| The air filter is in good condition. | | |

Operators Signature:

DO NOT OPERATE AN UNSAFE TRACTOR OR MACHINE



POWER ARM PRE-OPERATION INSPECTION

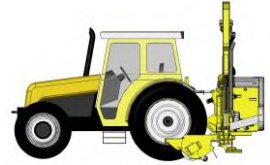

Power Arm ID Date: Shift:



WARNING: Before conducting the inspection, make sure the tractor engine is off, the key removed, all rotation has stopped and the tractor is in park with the parking brake engaged. Make sure the mower head is resting on the ground or is securely blocked up and supported and all hydraulic pressure has been relieved.

| Item | Condition at start of shift | Specific Comments if not O.K. |
|--|-----------------------------|-------------------------------|
| The operator's manual is in the canister on the mower. | | |
| All warning decals are in place, clean and legible. | | |
| All lights are clean and working. | | |
| The mounting frame bolts are in place and tight. | | |
| The arm pivot pins are tight and correctly secured. | | |
| There are no cracks in the arms. | | |
| Hydraulic cylinder pins are tight and correctly secured. | | |
| Hydraulic cylinder hose connections are tight. | | |
| Hydraulic pump hose connections are tight. | | |
| Hydraulic valve hose connections are tight. | | |
| Hydraulic valve controls function properly. | | |
| There are no damaged hoses. | | |
| The oil level is to the green mark on the tank sight glass. | | |
| There is no evidence of hydraulic oil leaks. | | |
| Flails are not missing, chipped, broken or excessively worn. | | |
| The flail bolts are tight. | | |
| The front and rear flaps are fitted and in good condition. | | |
| The front hood is in place and in good condition. | | |
| The wire trap is in good condition. | | |
| The skid shoes are in good condition and tight. | | |
| There are no cracks or holes in flail casing. | | |
| Hydraulic motor mounting bolts are tight. | | |
| All flail head nuts and bolts are tight. | | |
| The rotor bearings are in good condition and greased. | | |
| The roller bearings are in good condition and greased. | | |
| The drive line shaft guard is in good condition. | | |
| The drive line shaft guard is correctly secured. | | |
| Controls are securely mounted in the cab. | | |
| With engine running check arm operation. | | |
| Have a spare pack of flails, bushes, bolts and nuts. | | |

Operators Signature:

DO NOT OPERATE AN UNSAFE TRACTOR OR MACHINE



TRACTOR PRE-OPERATION INSPECTION

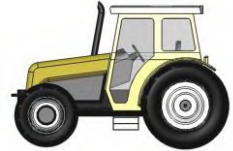

Power Arm ID Date: Shift:



WARNING: Before conducting the inspection, make sure the tractor engine is off, the key removed, all rotation has stopped and the tractor is in park with the parking brake engaged. Ensure any implement attached to the tractor is firmly on the ground.

| Item | Condition at start of shift | Specific Comments if not O.K. |
|---|-----------------------------|-------------------------------|
| The flashing lights function properly. | | |
| All lights are clean and working correctly. | | |
| All cab windows are clean and wipers working correctly. | | |
| The SMV sign, where required, is clean and visible. | | |
| The tyres are in good condition with correct pressure. | | |
| The wheel nuts are tight. | | |
| The tractor brakes are in good condition. | | |
| The steering linkage is in good condition. | | |
| There are no visible oil leaks. | | |
| The hydraulic controls function properly. | | |
| The ROPS or ROPS cab is in good condition. | | |
| The seatbelt is in place and in good condition. | | |
| The 3-point hitch is in good condition. | | |
| The drawbar/pick up hook is secure and in good condition. | | |
| The PTO master shield is in place. | | |
| The engine oil level is full. | | |
| The brake fluid level is full. | | |
| The power steering fluid level is full. | | |
| The fuel level is adequate. | | |
| The engine coolant fluid level is full. | | |
| The radiator and oil cooler are free of debris. | | |
| The air filter is in good condition. | | |

Operators Signature:

DO NOT OPERATE AN UNSAFE TRACTOR OR MACHINE

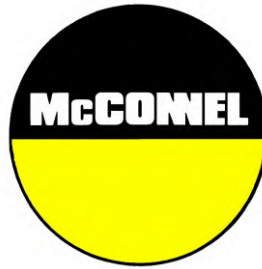

For Safety and Performance...

ALWAYS READ THE BOOK FIRST

McCONEL LIMITED

**Temeside Works
Ludlow
Shropshire
England**

**Telephone: +44 (0)1584 873131
www.mcconel.com**

- NOISE STATEMENT -

The equivalent daily personal noise exposure from this machine measured at the operators' ear is within the range 78 – 85 dB, these figures apply to a normal distribution of use where the noise fluctuates between zero and maximum. The figures assume that the machine is fitted to a tractor with a 'quiet' cab with the windows closed in a generally open environment. We recommend that the windows are kept closed. With the cab rear window open the equivalent daily personal noise exposure will increase to a figure within the range 82 – 88 dB. At an equivalent daily noise exposure level of 85 – 90 dB ear protection is recommended and must always be used if any window is left open.



Operating, servicing and maintaining this equipment can expose you to chemicals including gasoline, diesel fuel, lubricants, petroleum products, engine exhaust, carbon monoxide, and phthalates, which are known to the State of California to cause cancer and birth defects or other reproductive harm. To minimize exposure, avoid breathing exhaust, do not idle the engine except as necessary, service your vehicle in a well-ventilated area and wear gloves or wash your hands frequently when servicing your vehicle. Battery posts, terminals and related accessories contain lead and lead compounds, chemicals known to the state of California to cause cancer, birth defects or other reproductive harm. For more information go to www.P65Warnings.ca.gov. This website, operated by California's Office of Environmental Health Hazard Assessment, provides information about these chemicals and how individuals may be exposed to them.

CONTENTS

| | |
|------------------------------------|----|
| General Information | 1 |
| Specifications & Dimensions | 2 |
| Safety Information | 4 |
| Tractor Requirements | 12 |
| Vehicle / Tractor Preparation | 13 |
| Delivery & Pre-attachment | 14 |
| Hydraulic Oil | 15 |
| Machine Preparation & Attachment | 16 |
| Machine Attachment | 18 |
| Control Unit Installation | 22 |
| Operator Control Systems | 23 |
| Running Up Procedure | 24 |
| Emergency Stopping | 24 |
| Transportation | 25 |
| Transport Locks | 25 |
| Horizontal Head Rotation | 27 |
| Breakaway | 28 |
| Powered Slew | 30 |
| Slew Locks | 30 |
| EDS System | 31 |
| Float Kits | 31 |
| Pre-work Preparation & Precautions | 33 |
| Operating Speed | 34 |
| Hedgecutting Procedure | 35 |
| Hazards & Dangers | 36 |
| Overhead Power Lines | 37 |
| Flails Identification | 39 |
| General Maintenance | 41 |
| Service Schedule | 42 |
| Hydraulic System | 43 |
| Hydraulic Hoses | 44 |
| Flail Head | 45 |
| PTO Shaft Maintenance | 46 |
| Troubleshooting Chart | 47 |

GENERAL INFORMATION

Always read this manual before fitting or operating the machine – whenever any doubt exists contact your dealer or the McConnel Service Department for advice and assistance.

Use only McConnel Genuine Service Parts on McConnel Equipment and Machines

Definitions; *The following definitions apply throughout this manual:*

WARNING

An operating procedure, technique etc., which –
can result in personal injury or loss of life if not observed carefully.

CAUTION

An operating procedure, technique etc., which –
can result in damage to either machine or equipment if not observed carefully.

NOTE

An operating procedure, technique etc., which –
is considered essential to emphasis.

LEFT AND RIGHT HAND

This term is applicable to the machine when attached to the tractor and is viewed from the rear – this also applies to tractor references.

Note: The illustrations in this manual are for instructional purposes only and may on occasion not show some components in their entirety. In some instances an illustration may appear slightly different to that of your particular model but the general procedure will be the same. E&OE.

MACHINE & DEALER INFORMATION

Record the Serial Number of your machine on this page and always quote this number when ordering parts. Whenever information concerning the machine is requested remember also to state the make and model of tractor to which the machine is fitted.

| | |
|-------------------------------|---------------------------|
| Machine Serial Number: | Installation Date: |
| Machine Model details: | |
| Dealer Name: | |
| Dealer Address: | |
| Dealer Telephone No: | |
| Dealer Email Address: | |

Machine Identification

The machine is fitted with an identification plate that will include the following information:

1. *Model/Code (Part Number)*
2. *Serial No.*
3. *Machine Weight*

When ordering parts from your local dealer please quote machine part number and serial number as stated on this plate so that machine and model can be quickly identified.



Machine Identification Plate

SPECIFICATIONS & DIMENSIONS

Technical Specifications

| | |
|--|---|
| Machine | |
| Model | <i>PA5054 VERSI</i> |
| Description | <i>Dual Direction Front or Rear Mount</i> |
| Head Rotation | <i>Manual (Pin Locking)</i> |
| Tractor Requirements | |
| Minimum Power | <i>75HP</i> |
| Minimum Tractor Weight | <i>4500kg</i> |
| Front Mount Machines | <i>DIN Plate, Specialist Frame</i> |
| Rear Mount Machines | <i>3-Point Linkage or Axle Mounted</i> |
| Machine Specifications | |
| Maximum Reach | <i>5.0m (16'5")</i> |
| Powered Slew | <i>220°</i> |
| Breakback | <i>20°</i> |
| Power | <i>54HP</i> |
| Oil Tank Capacity | <i>110 Litres</i> |
| Machine Weight with <i>Flailhead (excl. Oil)</i> | <i>1071kg</i> |
| Hydraulic Oil Flow Rate | <i>90 l/min</i> |
| Oil Pressure (Max.) | <i>250BAR (3626PSI)</i> |

Dimensions

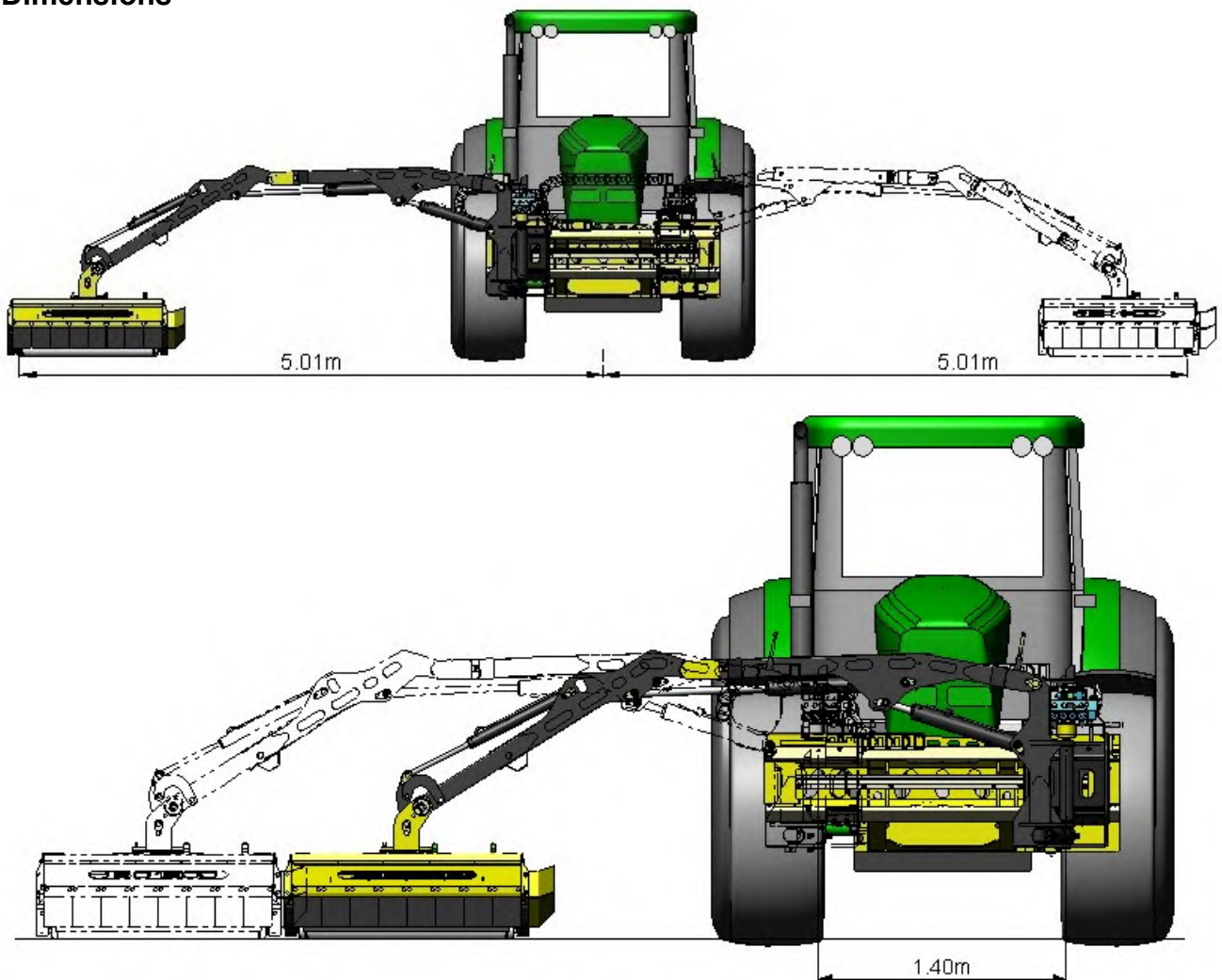

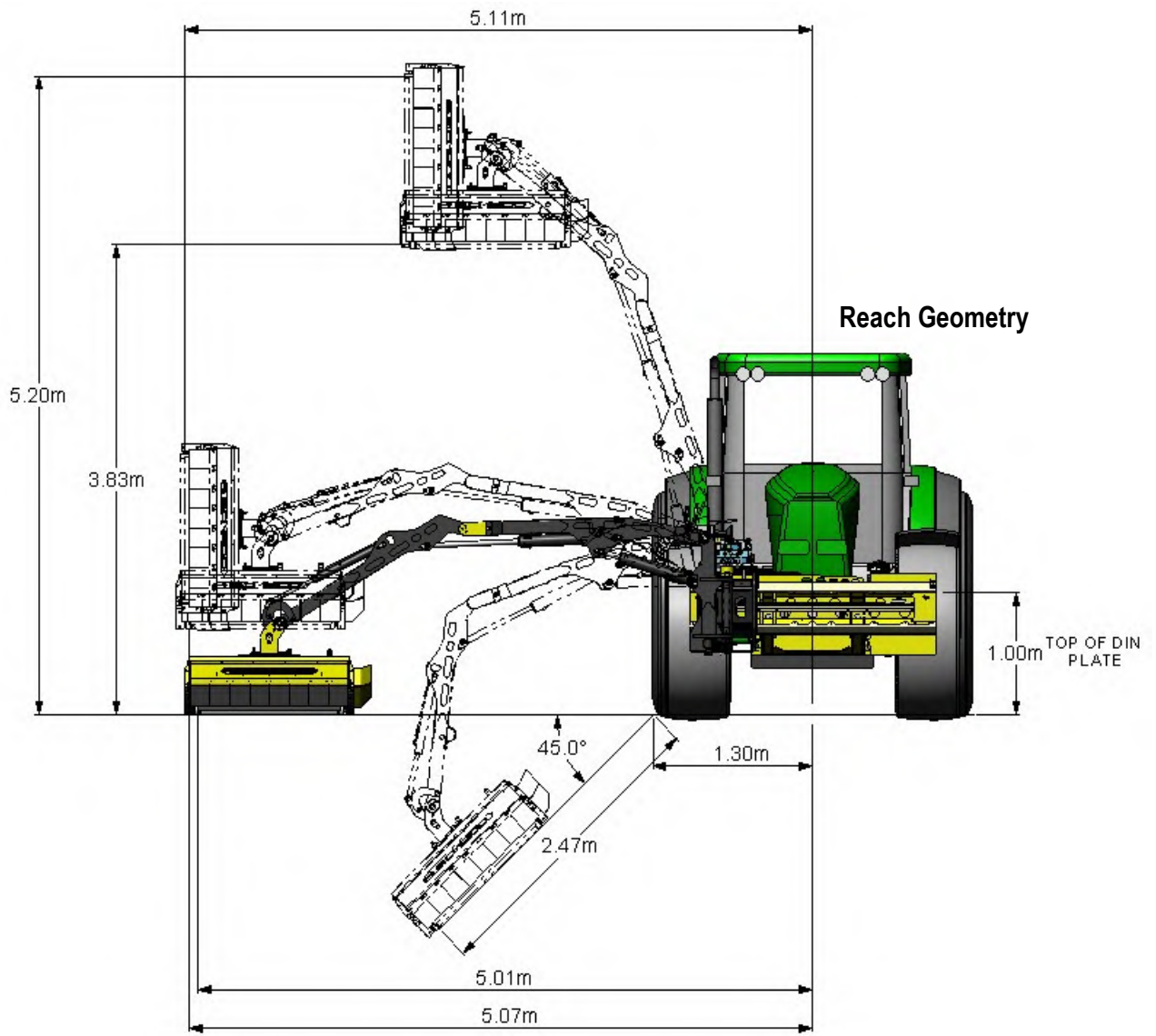

Transport Position

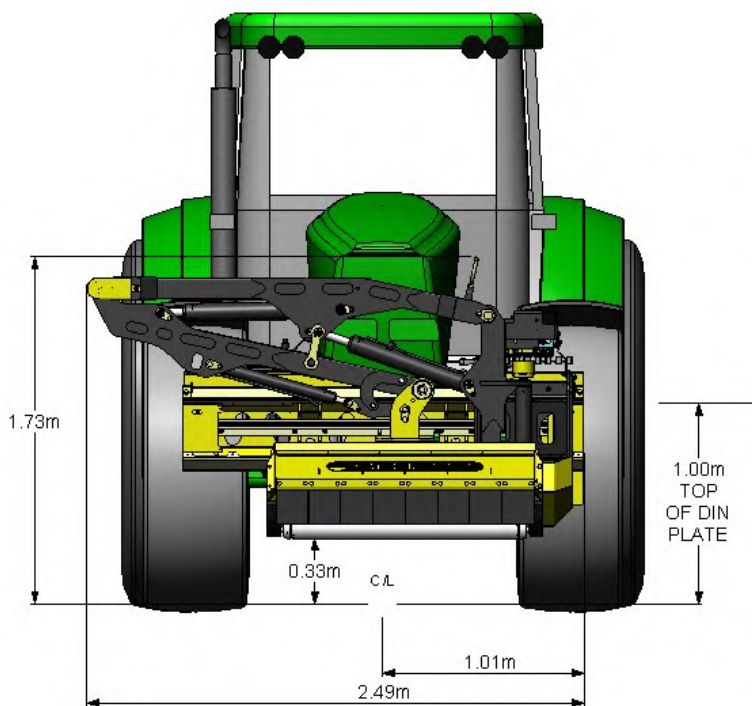

Alternative Transport Position

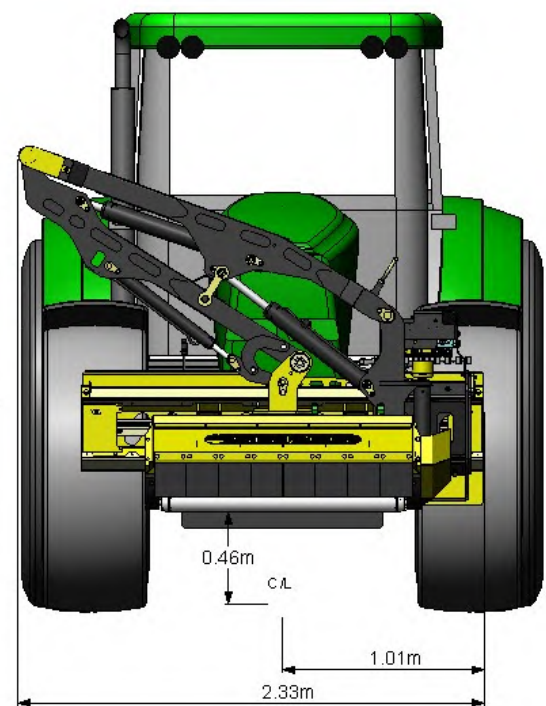



This machine has the potential to be extremely dangerous, in the wrong hands it can kill or maim. It is therefore imperative that both owner, and operator of this machine, read and understand the following section to ensure that they are fully aware of the dangers that do, or may exist, and their responsibilities surrounding the use and operation of the machine. The operator of this machine is responsible not only for their own safety but equally for the safety of others who may come into the close proximity of the machine, as the owner you are responsible for both.

When the machine is not in use the cutting head should be lowered to rest on the ground. In the event of a fault being detected with the machine's operation it should be stopped immediately and not used again until the fault has been corrected by a qualified technician.

POTENTIAL SIGNIFICANT DANGERS ASSOCIATED WITH THE USE OF THIS MACHINE:

- ▲ *Being hit by debris thrown by rotating components.*
- ▲ *Being hit by machine parts ejected through damage during use.*
- ▲ *Being caught on a rotating power take-off (PTO) shaft.*
- ▲ *Being caught in other moving parts i.e.: belts, pulleys and cutting heads.*
- ▲ *Electrocution from Overhead Power Lines (by contact with or 'flashover' from).*
- ▲ *Being hit by cutting heads or machine arms as they move.*
- ▲ *Becoming trapped between tractor and machine when hitching or unhitching.*
- ▲ *Tractor overbalancing when machine arm is extended.*
- ▲ *Injection of high-pressure oil from hydraulic hoses or couplings.*
- ▲ *Machine overbalancing when freestanding (out of use).*
- ▲ *Road traffic accidents due to collision or debris on the road.*

BEFORE USING THIS MACHINE YOU MUST:

- ▲ *Ensure you read all sections of the operator handbook.*
- ▲ *Ensure the operator is, or has been, properly trained to use the machine.*
- ▲ *Ensure the operator has been issued with and reads the operator handbook.*
- ▲ *Ensure the operator understands and follows the instructions in operator handbook.*
- ▲ *Ensure the tractor front, rear and sides are fitted with metal mesh or polycarbonate guards of suitable size and strength to protect the operator against thrown debris or parts.*
- ▲ *Ensure tractor guards are fitted correctly, are undamaged and kept properly maintained.*
- ▲ *Ensure that all machine guards are in position, are undamaged, and are kept maintained in accordance with the manufacturer's recommendations.*
- ▲ *Ensure flails and their fixings are of a type recommended by the manufacturer, are securely attached and that none are missing or damaged.*
- ▲ *Ensure hydraulic pipes are carefully and correctly routed to avoid damage by chaffing, stretching or pinching and that they are held in place with the correct fittings.*
- ▲ *Always follow the manufacturer's instructions for attachment and removal of the machine from the tractor.*
- ▲ *Check that the machine fittings and couplings are in good condition.*
- ▲ *Ensure the tractor meets the minimum weight recommendations of the machine's manufacturer and that ballast is used as necessary.*
- ▲ *Always inspect the work area thoroughly before starting to note obstacles and remove wire, bottles, cans and other debris.*
- ▲ *Use clear suitably sized warning signs to alert others to the nature of the machine working within that area. Signs should be placed at both ends of the work site. (It is recommended that signs used are of a size and type specified by the Department of Transport and positioned in accordance with their, and the Local Highways Authority, guidelines).*
- ▲ *Ensure the operator is protected from noise. Ear defenders should be worn and tractor cab doors and windows must be kept closed. Machine controls should be routed through proprietary openings in the cab to enable all windows to be shut fully.*
- ▲ *Always work at a safe speed taking account of the conditions i.e.: terrain, highway proximity and obstacles around and above the machine. Extra special attention should be applied to Overhead Power Lines. Some of our machines are capable of reach in excess of 8 metres (26 feet) this means they have the potential to well exceed, by possibly 3 metres (9' 9"), the lowest legal minimum height of 5.2 metres from the ground for 11,000 and 33,000 volt power lines. It cannot be stressed enough the dangers that surround this capability, it is therefore vital that the operator is fully aware of the maximum height and reach of the machine, and that they are fully conversant with all aspects regarding the safe minimum distances that apply when working with machines in close proximity to Power Lines. (Further information on this subject can be obtained from the Health & Safety Executive or your Local Power Company).*

- ▲ *Always disengage the machine, kill the tractor engine, remove and pocket the key before dismounting for any reason.*
- ▲ *Always clear up all debris left at the work area, it may cause hazard to others.*
- ▲ *Always ensure when you remove your machine from the tractor that it is left in a safe and stable position using the stands and props provided and secured if necessary.*

WHEN NOT TO USE THIS MACHINE:

- ▲ *Never attempt to use this machine if you have not been trained to do so.*
- ▲ *Never use a machine until you have read and understood the operator handbook, are familiar with it, and practiced the controls.*
- ▲ *Never use a machine that is poorly maintained.*
- ▲ *Never use a machine if guards are missing or damaged.*
- ▲ *Never use a machine on which the hydraulic system shows signs of wear or damage.*
- ▲ *Never fit, or use, a machine on a tractor that does not meet the manufacturer's minimum specification level.*
- ▲ *Never use a machine fitted to a tractor that does not have suitable front, rear and side(s) cab guarding made of metal mesh or polycarbonate.*
- ▲ *Never use the machine if the tractor cab guarding is damaged, deteriorating or badly fitted.*
- ▲ *Never turn a machine cutting head to an angle that causes debris to be ejected towards the cab.*
- ▲ *Never start or continue to work a machine if people are nearby or approaching - Stop and wait until they are at a safe distance before continuing. WARNING: Some Cutting Heads may continue to 'freewheel' for up to 40 seconds after being stopped.*
- ▲ *Never attempt to use a machine on materials in excess of its capability.*
- ▲ *Never use a machine to perform a task it has not been designed to do.*
- ▲ *Never operate the tractor or machine controls from any position other than from the driving seat, especially whilst hitching or unhitching the machine.*
- ▲ *Never carry out maintenance of a machine or a tractor whilst the engine is running – the engine should be switched off, the key removed and pocketed.*
- ▲ *Never leave a machine unattended in a raised position – it should be lowered to the ground in a safe position on a level firm site.*
- ▲ *Never leave a tractor with the key in or the engine running.*
- ▲ *Never carry out maintenance on any part or component of a machine that is raised unless that part or component has been properly substantially braced or supported.*
- ▲ *Never attempt to detect a hydraulic leak with your hand – use a piece of cardboard.*
- ▲ *Never allow children near to, or play on, a tractor or machine under any circumstances.*

ADDITIONAL SAFETY ADVICE

Training

Operators need to be competent and fully capable of operating this machine in a safe and efficient way prior to attempting to use it in any public place. We advise therefore that the prospective operator make use of relevant training courses available such as those run by the Agricultural Training Board, Agricultural Colleges, Dealers and McConnel.

Working in Public Places

When working in public places such as roadsides, consideration should be paid to others in the vicinity. Stop the machine immediately when pedestrians, cyclists and horse riders etc. pass. Restart only when they are at a distance that causes no risk to their safety.

Warning Signs

It is advisable that any working area be covered by suitable warning signs and statutory in public places. Signs should be highly visible and well placed in order to give clear advanced warning of the hazard. Contact the Department of Transport or your Local Highways Authority to obtain detailed information on this subject. The latter should be contacted prior to working on the public highway advising them of the time and location of the intended work asking what is required by way of signs and procedure. – ‘*Non-authorised placement of road signs may create offences under the Highways Act*’.

Suggested Warning Signs Required

“Road works ahead” warning sign with a supplementary **“Hedge cutting”** plate. **“For 1 mile”** or appropriate shorter distance may be added to the plate.

“Road narrows” warning sign with supplementary **“Single file traffic”** plate.

White on blue **“Keep right”** (*) arrow sign on rear of machine.

* Note – this applies to UK Market machines where traffic passes to the right of a machine working in the same direction as the traffic flow. The direction, use and colour of the arrow sign will depend on the country of use and the Local Highway Authorities regulations in the locality.

Use of Warning Signs

- On two-way roads one set of signs is needed facing traffic in each direction.
- Work should be within 1 mile of the signs.
- Work only when visibility is good and at times of low risk e.g.: NOT during ‘rush-hour’.
- Vehicles should have an amber-flashing beacon.
- Ideally, vehicles should be conspicuously coloured.
- Debris should be removed from the road and path as soon as practicable, and at regular intervals, wearing high visibility clothing and before removing the hazard warning signs.
- Collect all road signs promptly when the job is completed.

Although the information given here covers a wide range of safety subjects it is impossible to predict every eventuality that can occur under differing circumstances whilst operating this machine. No advice given here can replace ‘good common sense’ and ‘total awareness’ at all times but will go a long way towards the safe use of your McConnel machine.

Safe use of rotary flail hedge cutters

HSE information sheet

Agriculture Information Sheet No 21 (Revision 1)

Introduction

This information sheet outlines typical hazards when using most types of tractor-mounted rotary flail hedge cutter. It gives guidance on reducing risks to the operator and others during work with hedge cutters and will help employers, employees and the self-employed comply with their duties under health and safety law.

All users of rotary flail hedge cutters need to be aware of the particular features of their make/model of hedge cutter when considering the hazards, risks and precautions.

Hazards

The greatest risk of injury comes from contact with the machine's moving parts and in particular:

- entanglement on inadequately guarded power take-off shafts;
- contact with the cutter head parts, drive belts or pulleys;
- being struck by the cutting head or machine arm as it moves.

Other risks associated with tractor-mounted hedge cutters can include:

- being hit by material or other debris ejected by the cutters;
- being hit by component parts ejected from the machine;
- coming into contact with overhead electricity power lines (OHPLs);
- the tractor overbalancing when the machine arm is extended;
- injection of high-pressure oil from damaged hydraulic hoses or couplings;
- being struck by the machine overbalancing when un-hitched from the tractor;
- road traffic accidents due to collisions with other vehicles either directly or from debris on the road.

Control measures

It is extremely dangerous to carry out any work on a machine while it is under power. The most important safety measure is to follow the 'safe stop' procedure before dismounting, or carrying out any maintenance or adjustments, including dealing with a blockage or other problem:

- Handbrake on.
- Controls neutral.
- Stop engine.
- Remove key.

Guards and machine safety

Check that all guards and other protective devices are in place before starting work. Don't use the machine if the guards are missing or damaged. Make sure:

- the power take-off (PTO) shaft is fully enclosed in a guard along its entire length from the tractor power take-off to the power input connection on the hedge cutter;
- the tractor rear and side(s) are fitted with protective glazing, metal mesh or polycarbonate guards of a size/strength specified by the hedge cutter manufacturer to protect the operator against thrown debris or other projectiles;
- tractor mesh/polycarbonate guards are suitable for the job, undamaged and maintained in accordance with the manufacturer's instructions;
- all hedge cutter guards and safety devices are in position, correctly fitted and maintained in accordance with the manufacturer's recommendations;
- flails and their fixing heads are the right size for the task. Flails, and their fixings, should be of the type recommended by the manufacturer, securely attached, and should not be missing or damaged;
- hydraulic pipes are carefully routed to avoid damage;
- machine fittings and couplings are in good condition.

General guidance on safe working practice

- Operators should receive adequate instructions and training to enable them to use the machine safely. Take advantage of relevant training/courses provided by manufacturers/dealers. They will help ensure your safety and that of your staff, and help you get the best performance from your hedge cutter.
- Make sure the operator reads, understands and follows the instruction manual.
- Follow the manufacturer's instructions when hitching or unhitching the machine from the tractor. Do not stand in any position where you may be at risk of being crushed, eg in the area between the back of the tractor and the cutter.
- Make sure the machine is left in a stable position when it is removed from the tractor, using any stands or props provided, and securing it further if necessary.
- Do not carry out maintenance on the hedge cutter with the cutting arm/dipper arm raised, unless the arm is properly supported.
- Check the tractor is at least the minimum weight recommended by the hedge cutter manufacturer. Use ballast as necessary.
- Inspect the hedge before starting to cut and remove wire, bottles, cans and other debris. Check for any telegraph/electricity pole stays. Damaged stays should be reported to the relevant Telecoms Company/Distribution Network Operator.
- Use appropriate warning signs to alert others to the hedge-cutting operation where necessary.
- Work at a safe speed, taking account of the conditions (eg terrain, proximity to the highway, or obstacles).
- Use safe practices when work needs to be done near OHPLs. Flailhead units on some dipper arms can reach over 5.2 metres, the minimum height of OHPLs above ground level (see Further reading).
- Clear up debris after cutting if it could be a hazard to others.

Roadside hedges

Take extra care if you are hedge/verge cutting along a road. Consider what measures you will need to control the risks to other road users (eg vehicles, cyclists, pedestrians, or horse riders). For roadside work (on the public highway) there are other legal requirements. For example, there may be obligations to:

- display specific warning signs in defined locations where work is carried out;
- fit flashing beacons to tractors/machines;
- clear debris from paths and roads;
- restrict your working hours.

Consult your local authority highways department and the Department for Transport for advice (see Further reading).

Further reading

Traffic signs manual 2009. Chapter 8. Traffic safety measures and signs for road works and temporary situations. Part 2: Operations DfT ISBN 978 0 11 553052 4 <http://assets.dft.gov.uk/publications/traffic-signs-manual/traffic-signs-manual-chapter-08-part-02.pdf>

Working safely near overhead electricity power lines AIS8(rev3) HSE Books 2012 www.hse.gov.uk/pubns/ais8.htm

Further information

For information about health and safety, or to report inconsistencies or inaccuracies in this guidance, visit www.hse.gov.uk/. You can view HSE guidance online and order priced publications from the website. HSE priced publications are also available from bookshops.

This guidance is issued by the Health and Safety Executive. Following the guidance is not compulsory, unless specifically stated, and you are free to take other action. But if you do follow the guidance you will normally be doing enough to comply with the law. Health and safety inspectors seek to secure compliance with the law and may refer to this guidance.

This document is available at www.hse.gov.uk/pubns/ais21.htm.

© *Crown copyright* If you wish to reuse this information visit www.hse.gov.uk/copyright.htm for details. First published 10/12.

SAFETY & INFORMATION DECALS (Power Arms)

Power Arm machines are equipped with safety and information decals designed to warn of dangers, operational information and machine protection. Operators must understand the decals and heed all warnings. Keep decals in a good condition and replace immediately if they are damaged or missing.



1.



2.

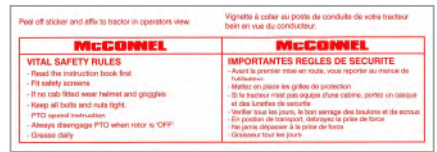

4.



5.



6.



7.



8.



9.



10.



11.



12.



13.



14.



15.

1. General Safety Warnings.
2. Driveline Hazard Warning.
3. Tighten Check Chains Warning.
4. 'In vehicle' Safety Rules Decal.
5. Serial Number Plate.
6. Read the Book First.
7. Lift Point with SWL (Kg).
8. Specific Pinch Point Warning.
9. Maximum vehicle PTO Speed & Direction Warning.
10. Oil Filter Initial and subsequent change information.
11. Lift Point for shipping only; stow when machine installed on vehicle. (Models with stowable lift eyes only).
12. Auto-breakaway Return Warning; in 'Auto-Reset' arm will automatically return to the work position, when possible.
13. Vehicle Clearance Warning; leave 300mm+ between arm and vehicle.
14. Lift Stop Clearance Warning; leave 300mm+ between arm and vehicle, leave 5mm between arm and stop.
15. Lift Tap 'Lock' Warning; leave 300mm+ between arm and vehicle, lock lift taps for transport.

SAFETY & INFORMATION DECALS (Flail Heads)

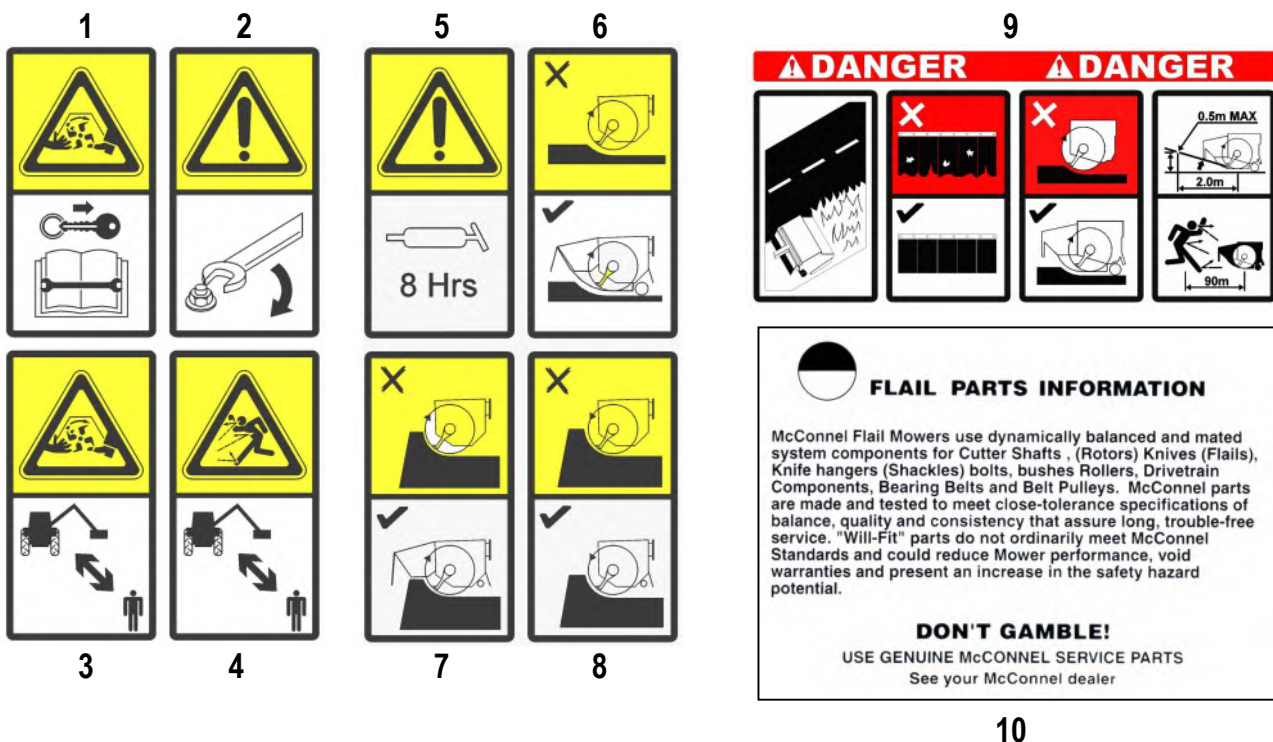

1. **Caution!** Rotating blades; keep clear of machine, stop machine (wait for rotor to stop), remove vehicle key and read the book first before performing any service or maintenance.
2. **Caution!** Keep all nuts and bolts tight.
3. **Caution!** Rotating components; keep clear of the working machine.
4. **Caution!** Thrown objects risk; keep all persons at a safe distance from the working machine.
5. **Caution!** Lubricate greasing points every 8 working hours.
6. **Caution!** Grass/Verge Mowing; front hood, front flap, rear roller and rear flap must be fitted and correctly adjusted when using the machine for grass and verge mowing. Flaps must be in good condition.
7. **Caution!** Hedging (Uphill cutting); front hood, front flap and rear flap must always be fitted and correctly adjusted. Rear roller should be placed into the raised position. Flaps must be in good condition.
8. **Caution!** Hedging (Downhill cutting); front hood may be removed; rear flap must be fitted and rear roller placed into the raised position. Flap must be in good condition.
9. **Danger!** Road side mowing. Flaps must be in good condition. Do not work if front hood, front flaps, rear roller and rear flaps not fitted. Front hood, front flaps, rear roller and rear flaps must be fitted. Adjust front hood to the correct height position for verge mowing. A extended straight line from the bottom of the rotor and bottom of the front flap should not be higher than 0.5m at a horizontal distance of 2.0m from the rotor. Keep all persons at 90m from the working machine, stop machine if persons are closer. *Refer to front hood height setting section for details.*
10. **Important!** Parts information; for safety and performance only use 'Genuine McConnel Service Parts'.

TRACTOR REQUIREMENTS

Tractor Weight *(Including ballast weight if necessary)*

Minimum 4500kg

HP Requirement

Minimum 75HP

PTO Shaft

Tractor must be equipped with a live drive PTO to enable continuous flailhead operation when forward motion of the tractor is stopped.

Check Chains / Stabilizers

Check chains or stabilizers must be fitted and tightened.

Front Mounted Models

Before fitting a front mounted machine to your tractor seek the advice of the tractor manufacturer or your local dealer regarding its suitability and all information in relation to additional linkage, ballast or weight that may be required.

CAUTION



Never attach a machine to a tractor that is unsuitable or poorly maintained – where doubt exists always seek the advice of the tractor manufacturer or your local dealer before attempting to fit the machine.

VEHICLE / TRACTOR PREPARATION

We recommend vehicles are fitted with cabs using 'safety glass' windows and protective guarding when used with our machines.

Fit Operator Guard (Part No. 7313324) using the hooks provided. Shape the mesh to cover all vulnerable areas. The driver must be looking through mesh and/or polycarbonate glazing when viewing the flail head in any working position - unless the vehicle/ cab

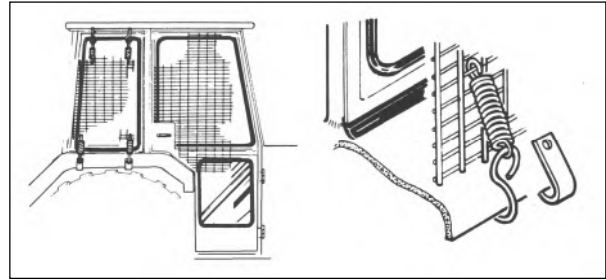

manufacturer can demonstrate that the penetration resistance is equivalent to, or higher than, that provided by mesh/polycarbonate glazing. If the tractor has a roll bar only, a frame must be made to carry both mesh and polycarbonate glazing. The operator should also use personal protective equipment to reduce the risk of serious injury such as; eye protection (mesh visor to EN1731 or safety glasses to EN166), hearing protection to EN352, safety helmet to EN297, gloves, filter mask and high visibility clothing.

Vehicle Ballast: It is imperative when attaching 'third-party' equipment to a vehicle that the maximum possible stability of the machine and vehicle combination is achieved – this can be accomplished by the utilization of 'ballast' in order to counter-balance the additional equipment added. **Front weights** may be required for rear mounted machines to place 15% of total outfit weight on the front axle for stable transport on the road and to reduce 'crabbing' due to the drag of the cutting unit when working on the ground.

Rear weights may be required to maintain a reasonable amount of rear axle load on the opposite wheel from the arms when in work; for normal off-ground work i.e. hedge cutting this should be 20% of rear axle weight or more for adequate control, and for ground work i.e. verge mowing with experienced operators, this can be reduced to 10%.

All factors must be addressed in order to match the type and nature of the equipment added to the circumstances under which it will be used – in the instance of Power Arm Hedgecutters it must be remembered that the machines centre of gravity during work will be constantly moving and will differ from that during transport mode, therefore balance becomes critical.

Factors that effect stability:

- *Centre of gravity of the tractor/machine combination.*
- *Geometric conditions, e.g. position of the cutting head and ballast.*
- *Weight, track width and wheelbase of the tractor.*
- *Acceleration, braking, turning and the relative position of the cutting head during these operations.*
- *Ground conditions, e.g. slope, grip, load capability of the soil/surface.*
- *Rigidity of implement mounting.*

Suggestions to increase stability:

- *Increasing rear wheel track; a vehicle with a wider wheel track is more stable.*
- *Ballasting the wheel; it is preferable to use external weights but liquid can be added to around 75% of the tyre volume – water with anti-freeze or the heavier Calcium Chloride alternative can be used.*
- *Addition of weights – care should be taken in selecting the location of the weights to ensure they are added to a position that offers the greatest advantage.*
- *Front axle locking (check with tractor manufacturer).*

NOTE: The advice above is offered as a guide for stability only and is not a guide to vehicle strength. It is recommended that you consult your vehicle manufacturer or local dealer to obtain specific advice on this subject, additionally advice should be sought from a tyre specialist with regard to tyre pressures and ratings suitable for the type and nature of the machine you intend to fit.

DELIVERY & PRE-ATTACHMENT (Dealer Reference)

Delivery

Where a machine is delivered in a partially dismantled condition secured with transport straps and banding a firm level site should be selected on which to place the machine before removing the straps, banding and other loose items.

Handling the Machine

Handling of the machine should always be performed using suitable overhead lifting equipment with a minimum safe lifting capacity over and above the maximum weight of the machine. Always ensure the machine is balanced during the lifting procedure and that all bystanders are kept well clear of the raised machine. Always ensure parking legs are correctly attached and secured before allowing the weight of the machine to rest on them.

Parking Legs

3-Point Linkage Mounted Models

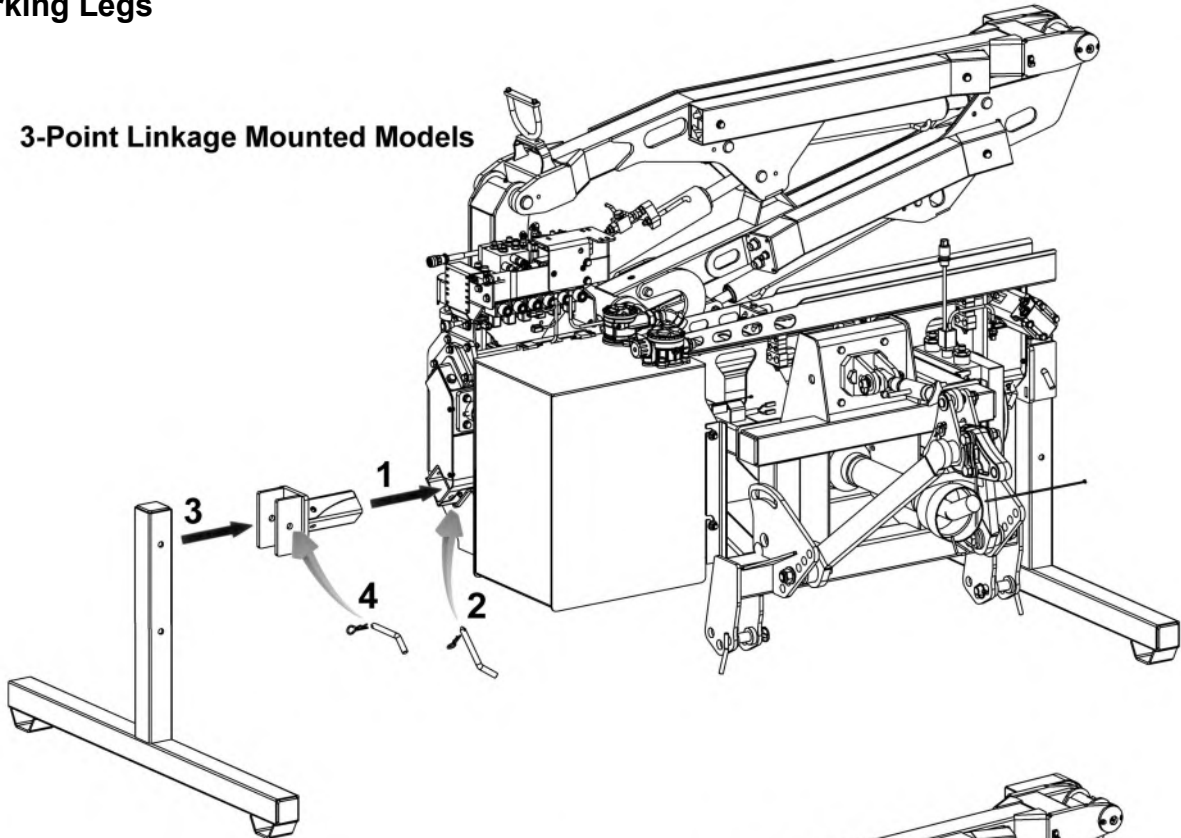

DIN Plate Mounting Models

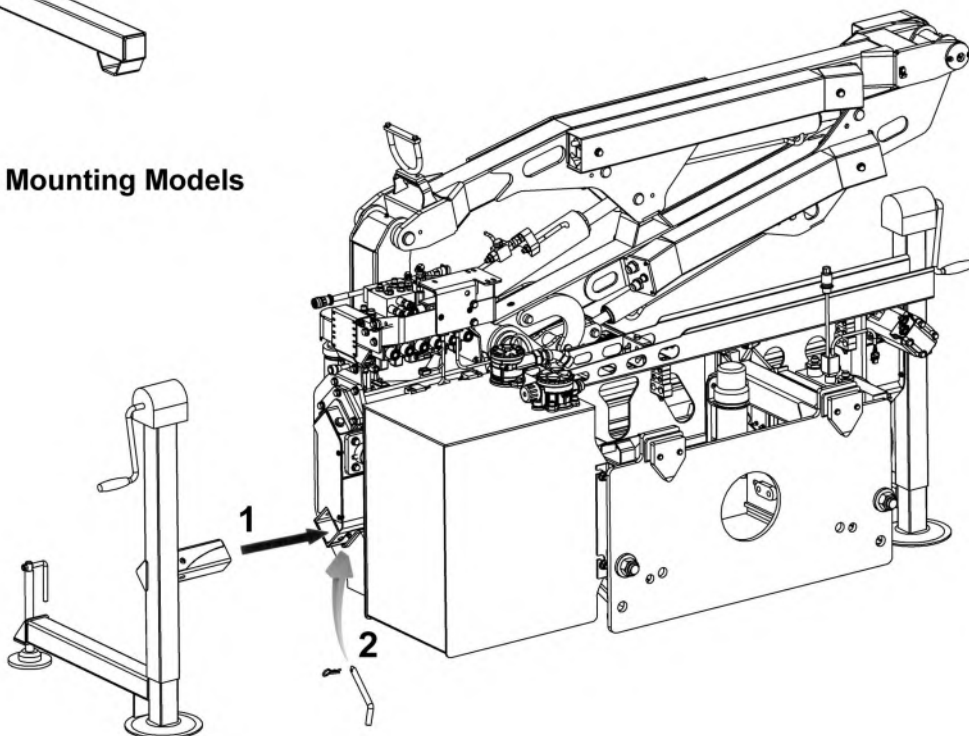

HYDRAULIC OIL

Hydraulic Oil Reservoir

Fill the tank with oil selected from the chart below or a good quality equivalent to a point where the level is between the minimum and maximum marks on the tank gauge. When the machine is initially run the level will drop as the oil is drawn into the circuit - *top back up as required to the correct level on the gauge.*

Always use clean receptacles when handling and transferring oil to avoid moisture or dirt contamination that can damage components and/or reduce machine performance.

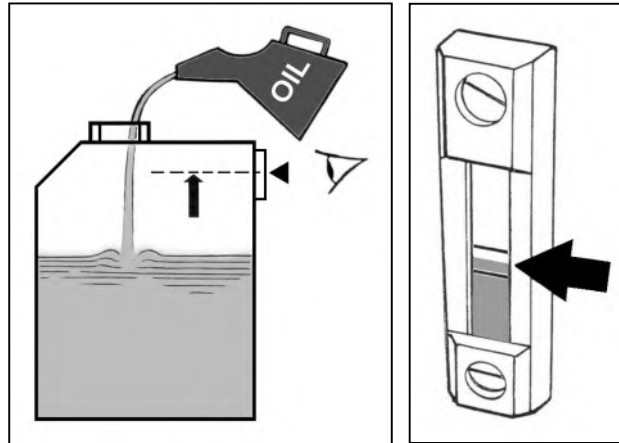

NOTE: Refer to the maintenance section for further information on the subject of hydraulic oil and system filtration.

Reservoir Capacity

The oil tank capacity of the machine is approximately **110 Litres**.

Recommended Hydraulic Oils

For initial filling of the oil reservoir, periodic oil changes and replenishment purposes the following hydraulic oils, or a good quality equivalent, are recommended;

NOTE: Only use oils that are ISO 18/13 or cleaner.

| Manufacturer | Cold or Temperate Climate | Hot Climate |
|-------------------------------|---|---|
| BP | <i>Bartran 46</i> <i>Energol HLP-HM 46</i> | <i>Bartran 68</i> <i>Energol HLP-HM 68</i> |
| CASTROL | <i>Hyspin AWH-M 46</i> | <i>Hyspin AWH-M 68</i> |
| COMMA | <i>Hydraulic Oil LIC 15</i> | <i>Hydraulic Oil LIC 20</i> |
| ELF | <i>Hydrelf HV 46</i> <i>Hydrelf XV 46</i> | <i>Hydrelf HV 68</i> |
| ESSO | <i>Univis N 46</i> | <i>Univis N 68</i> |
| FUCHS (UK/Non UK markets*) | <i>Renolin 46</i> <i>Renolin HVZ 46</i> <i>Renolin CL46/B15*</i> <i>Renolin AF46/ZAF46B*</i> | <i>Renolin 68</i> <i>Renolin HVZ 68</i> <i>Renolin CL68/B20*</i> <i>Renolin AF68/ZAF68B*</i> |
| GREENWAY | <i>Excelpower HY 68</i> | <i>Excelpower HY 68</i> |
| MILLERS | <i>Millmax 46</i> <i>Millmax HV 46</i> | <i>Millmax 68</i> <i>Millmax HV 68</i> |
| MORRIS | <i>Liquimatic 5</i> <i>Liquimatic HV 46</i> <i>Triad 46</i> | <i>Liquimatic 6</i> <i>Liquimatic HV 68</i> <i>Triad 68</i> |
| SHELL | <i>Tellus 46</i> <i>Tellus T46</i> | <i>Tellus 68</i> <i>Tellus T68</i> |
| TEXACO | <i>Rando HD 46</i> <i>Rando HDZ 46</i> | <i>Rando HD 68</i> <i>Rando HDZ 68</i> |
| TOTAL | <i>Equivis ZS 46</i> | <i>Equivis ZS 68</i> |

MACHINE PREPARATION & ATTACHMENT

The attachment procedure must always be performed on a firm level site, never attempt to attach the machine on sloping or soft ground. Keep all bystanders at a safe distance.

Parking Legs (3-point Linkage Mounted Machines)

3-point linkage mounted machines have 2 stand leg height positions; the lower position is for use when shipping the machine and the higher position is for machine parking, the latter position will place the machine at a suitable height for easy attachment and removal. Suitable overhead lifting gear will be required to raise the machine to change the positions of the legs on a free standing machine. The legs are held in position with pins and security clips.

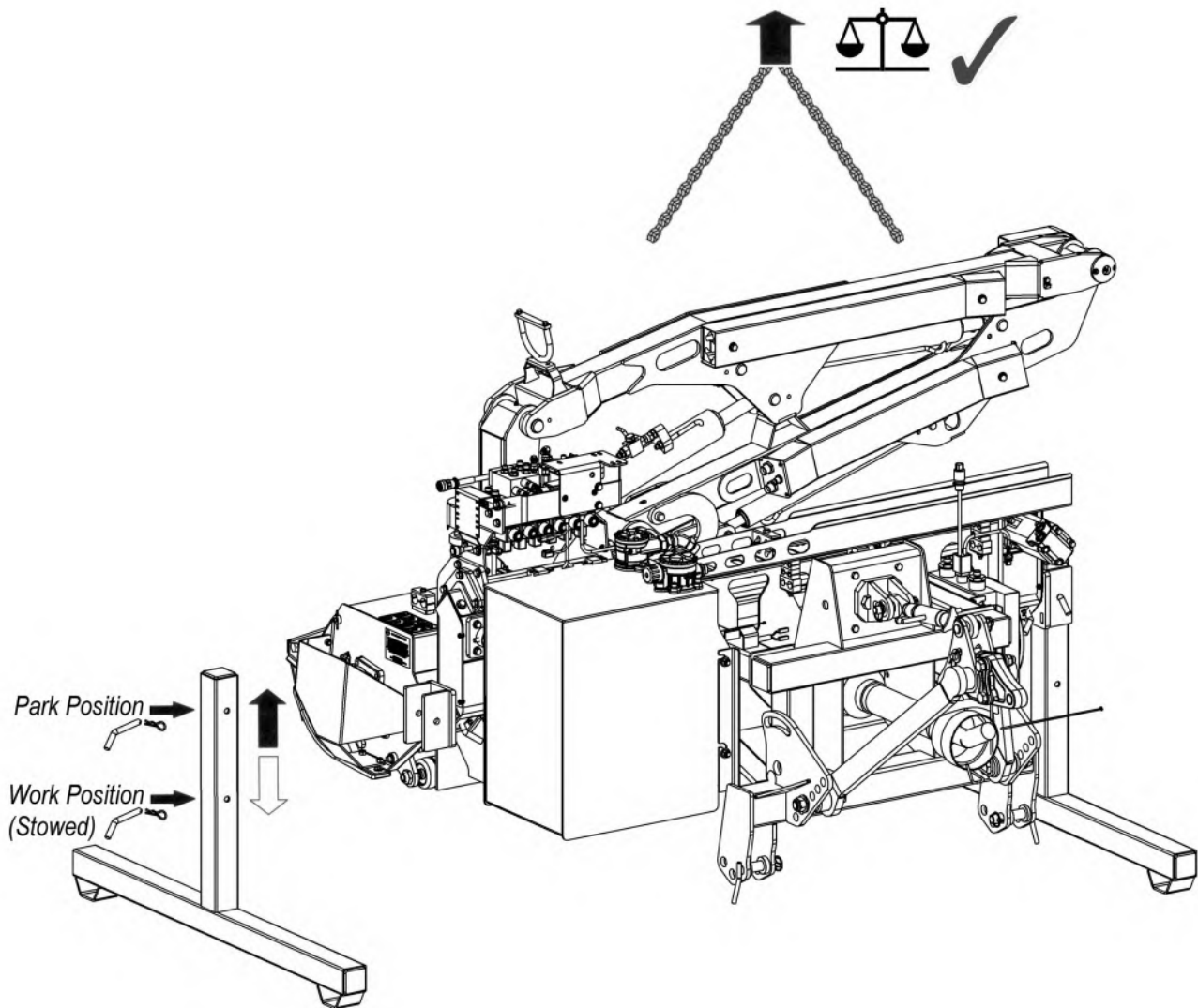

Parking Legs (DIN Plate Mount Machines)

DIN plate mounted machines are fitted with jack legs that can be adjusted to the required height for mounting the machine; these legs are also fitted with screw adjusters for vertical levelling of the machine. Adjustment of the jack legs should be made incrementally on each side until the correct height is achieved.

Levelling the Machine

It is important for attachment that the machine is levelled in both the side to side and front to back directions, the procedure for this is as follows:

Vertical Adjustment

Bring the frame of the machine into the vertical position by adjusting the screw feet of the stand legs on each side of the machine; rotating the feet clockwise will raise the front of the machine and anti-clockwise will lower it – see *illustration below*:

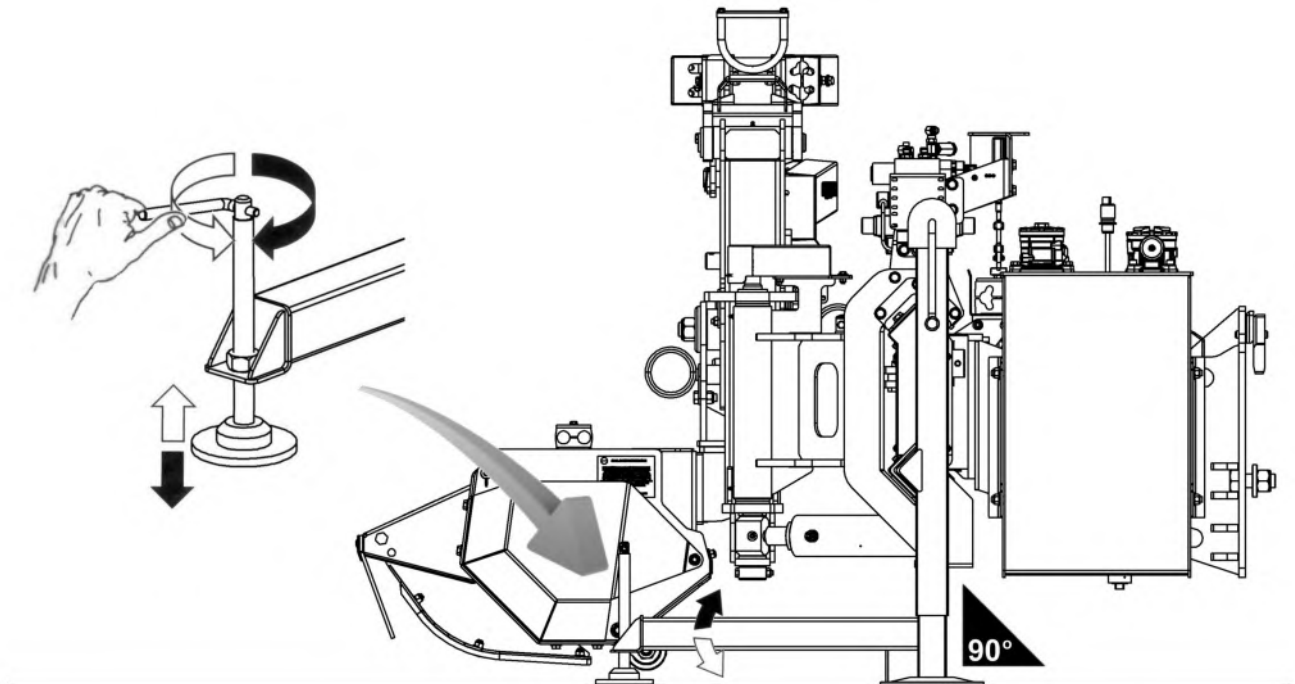

Horizontal Adjustment & Height

Raise the machine to the required attachment height by use of the stand leg ratchet jacks located on each side of the machine; for ease of operation, and reasons of stability, this should be done by alternately operating each jack to raise the machine in steps of approximately 50mm at a time until the desired height is achieved – see *illustration below*. Ensure the machine is level (side to side) at the end of the procedure.

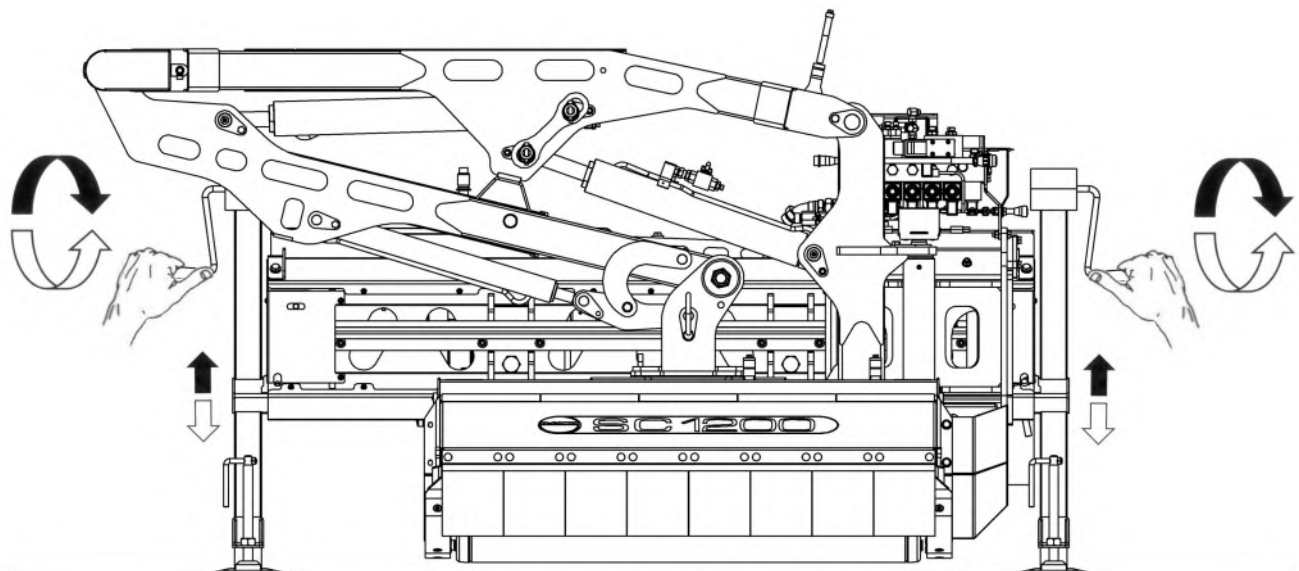

ATTACHING THE MACHINE – DIN Plate Front Mount Models

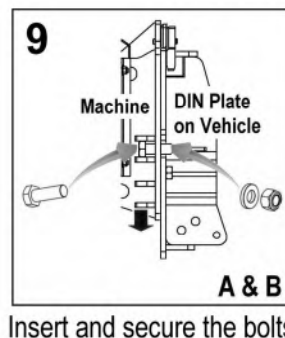
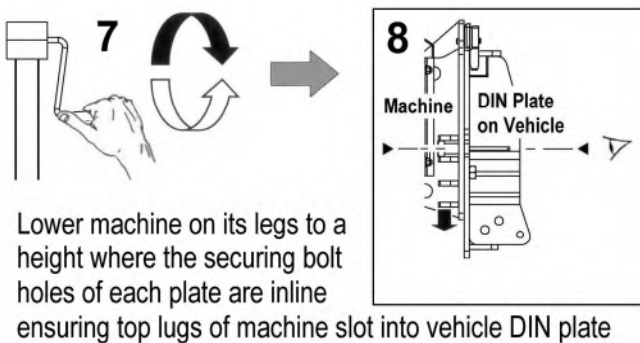
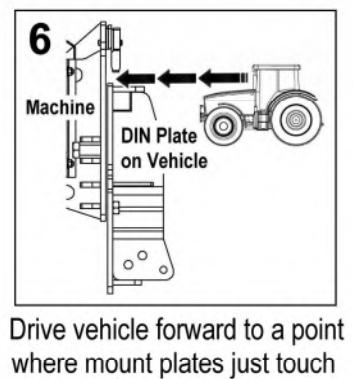
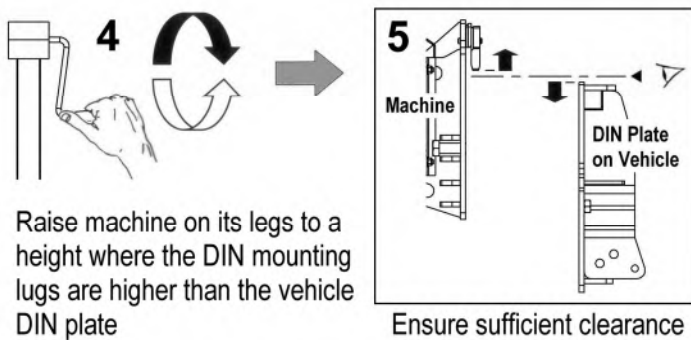
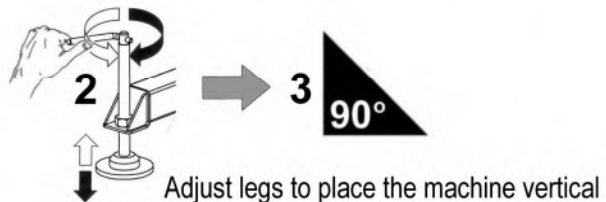
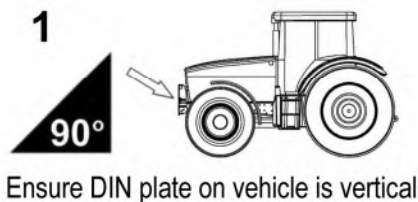
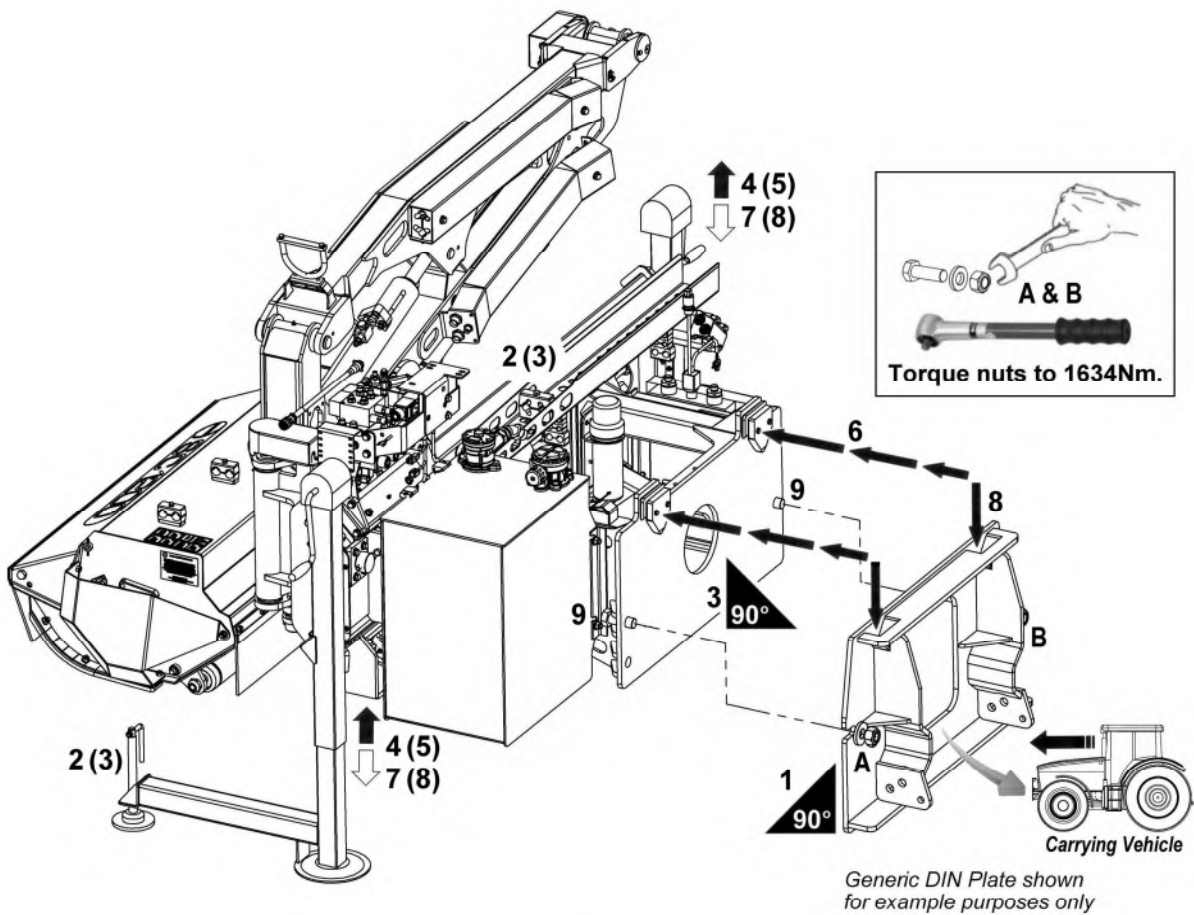

PTO DRIVESHAFT INSTALLATION

The PTO driveshaft attaches between the tractor and the machine gearbox to transfer the power required to run and operate the machine – it is important to achieve the correct shaft length to avoid risk of it ‘bottoming out’ when raising or lowering the machine. The procedure for measuring and cutting the shaft is as follows;

Measuring the PTO Shaft

With the machine attached to the tractor in the working position measure the horizontal distance ‘A’ from the tractor’s PTO to the input shaft on the machines gearbox and subtract 75mm (3”) – *this figure is the required shaft length.*

Place the fully closed PTO shaft on the ground and measure its overall length, if the shaft is shorter than the required length you can use it without the need to shorten - *providing it allows for a minimum 150mm (6”) overlap when fitted.*

If the shaft is longer subtract the required shaft length plus an additional 75mm (3”) - *the resulting figure is the excess length that will need to be removed from each half of the shaft.*

Cutting the PTO Shaft

Separate the two halves and using the measurement obtained above shorten both the plastic guarding and the inner steel profile tubes of each shaft by this same amount. De-burr the cut tubes with a file to remove rough or sharp edges and thoroughly clean to remove swarf before greasing, assembling and fitting the shaft.

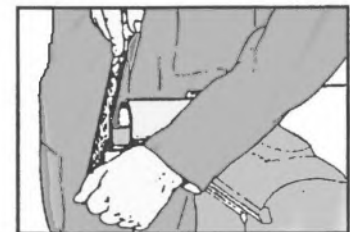
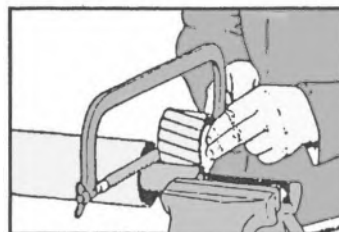
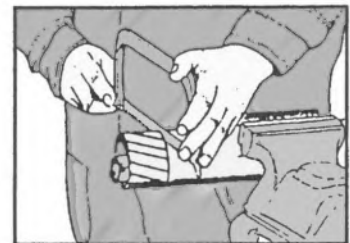
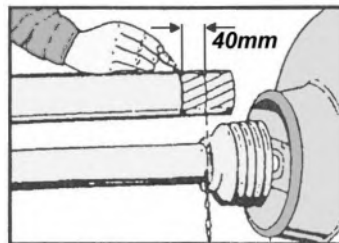
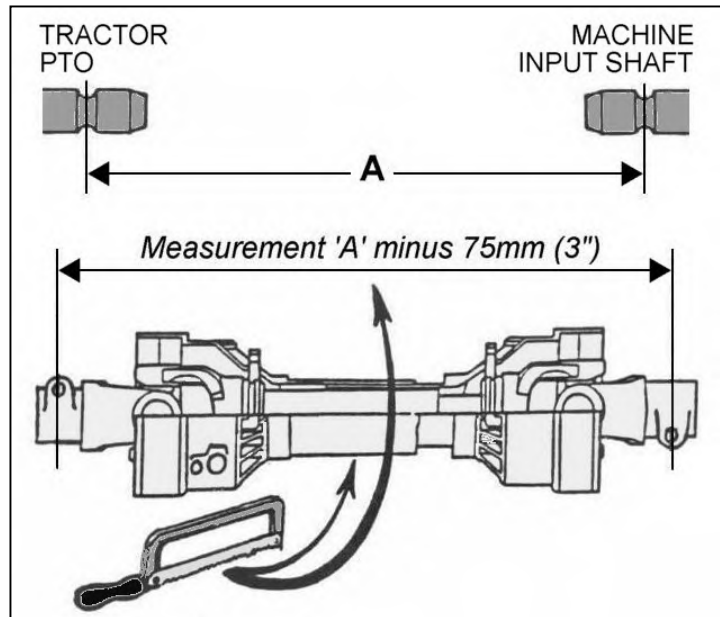

NOTE: For subsequent use with different tractors the shaft should be measured again to check suitability – *there must be a minimum shaft overlap of 150mm (6”).*

Torque Chains

Torque chains should be fitted to prevent the guards from rotating with the shaft, attach chains to suitable fixed components on the machine and tractor.

Maintenance

To increase the working life of the PTO shaft it should be periodically checked, cleaned and lubricated – *refer to the PTO maintenance section for further details on this subject.*

ATTACHING THE MACHINE – 3-Point Linkage Mounted Models

Reverse tractor slowly to the machine with link arms set at same height as lower attachment points on machine.

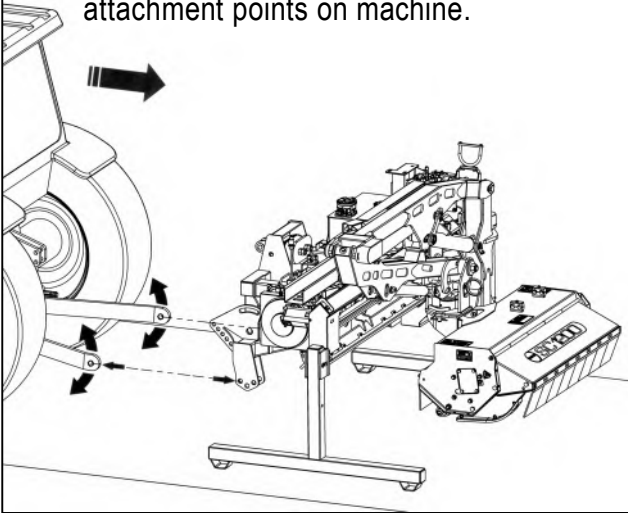

Secure link arms to each side of machine with linkage pins, spacer washers and lynch pins.

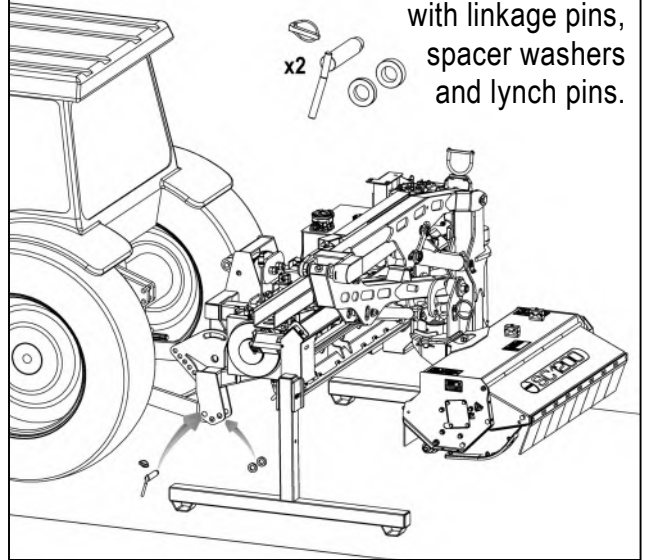

Fit Stabilizer Assembly and secure with fixings provided.

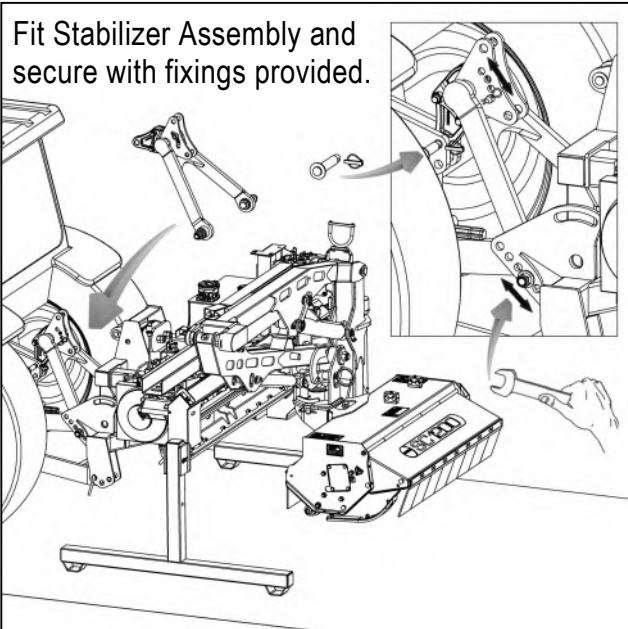

Fit Top Link between tractor and machine; secure with pins and lynch pins.

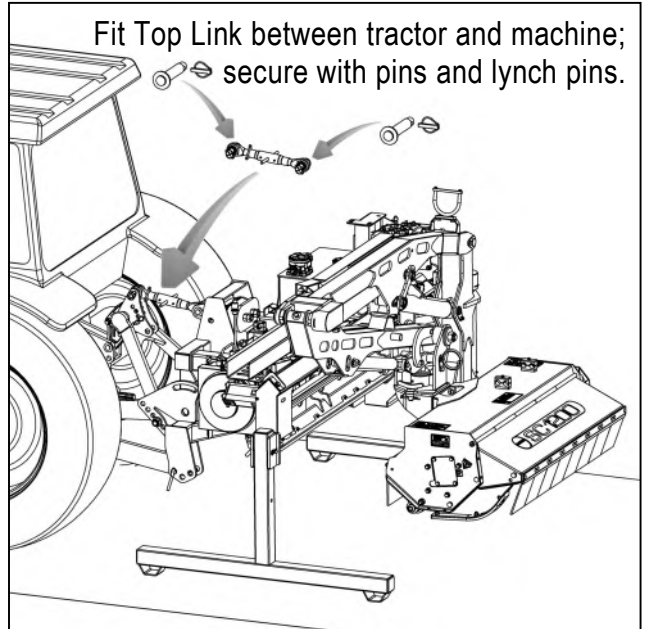

Raise the machine on linkage until shafts align.

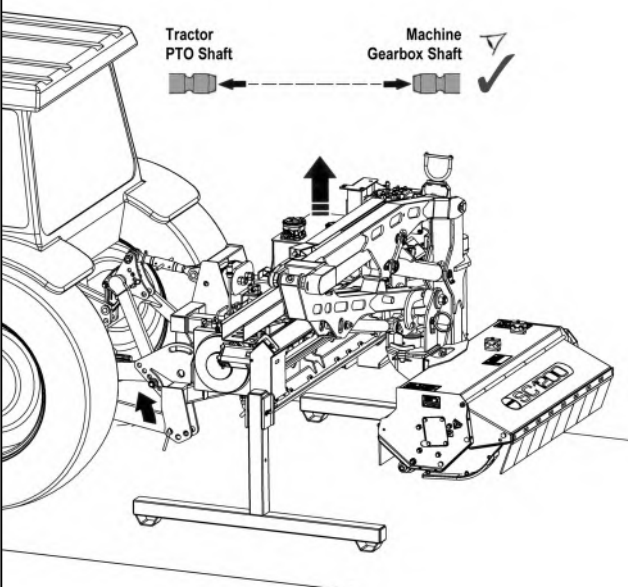

Adjust Top Link to set machine vertical.

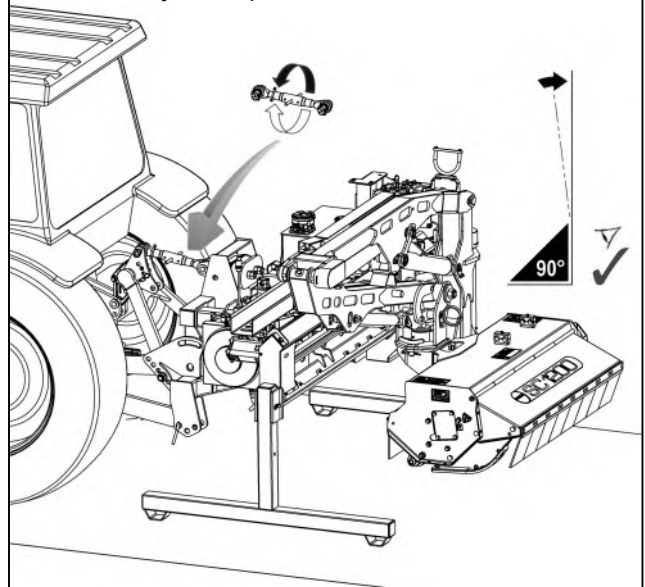

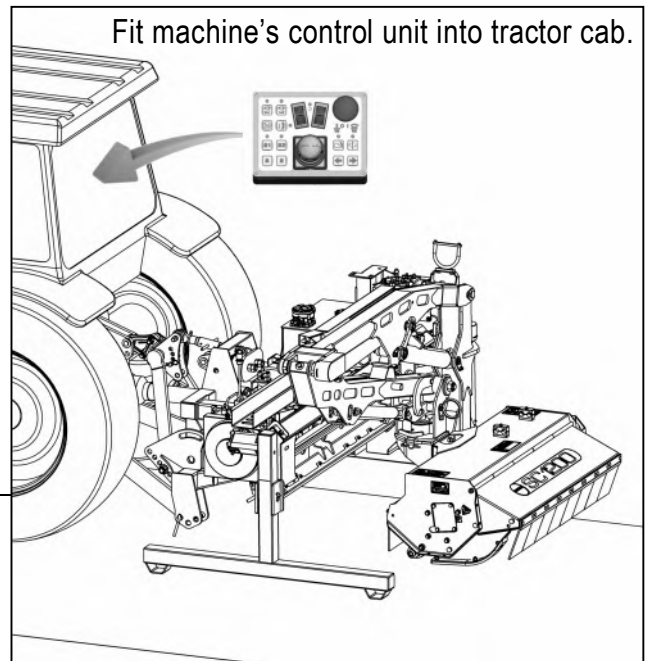
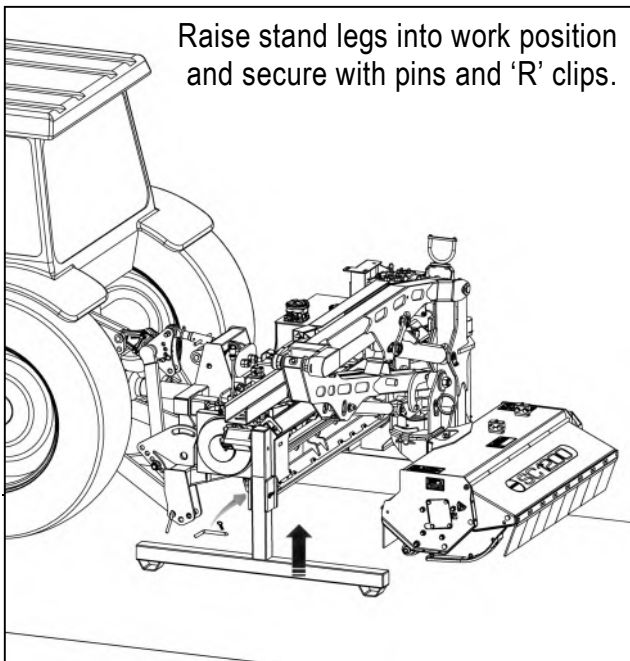
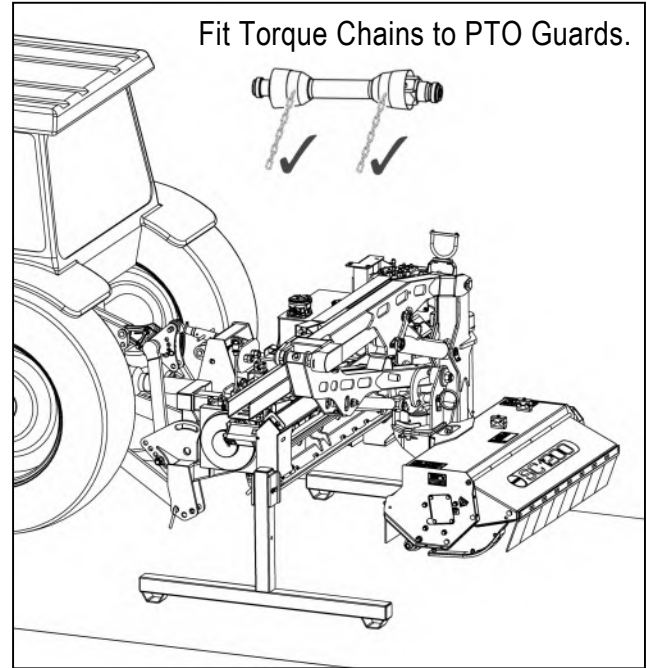
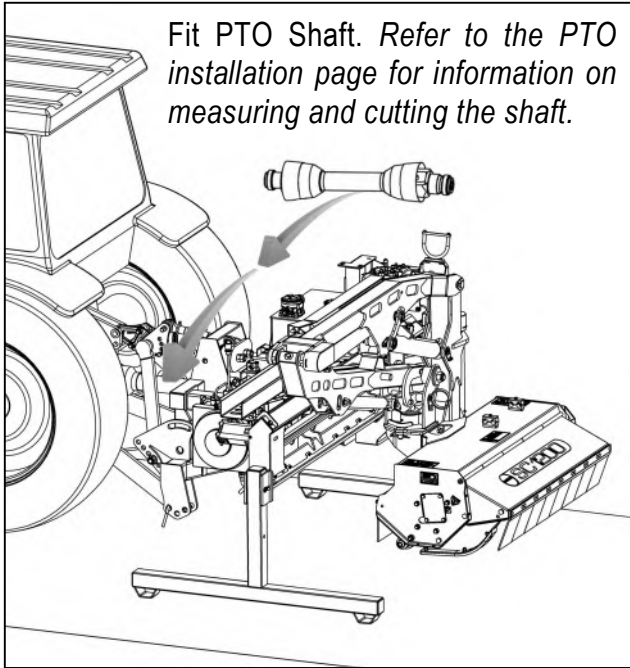

Machine Removal

Removal of the machine is basically a reversal of the attachment procedure. When parking the machine for removal or storage always select a firm level site in a safe location that will also allow for ease of future attachment. The arms should be fully folded into the machine and centrally positioned to give maximum stability and balance to the unit prior to removal. Once removed the machine should be placed into its lowest position on the legs - refer to horizontal adjustment and height section for operation of the stand leg jacks. Ensure the machine is left level and secure at all times, if necessary use suitable props or blocks for added support.

Storage

For long term storage it is recommended that the machine is sited in a clean dry environment where it is protected from the elements. Prior to storage the machine should be thoroughly cleaned and lubricated.

Ensure the machine is always stored in a safe manner and does not risk any kind of danger to persons or animals.

CONTROL UNIT INSTALLATION

The information below states installation methods for fitting control units in the tractor cab.

NOTE: Electric control units work within the range of **12v-16v DC** and require a minimum power supply of **12v DC**.

Electric Controls : Motion / Evolution

Motion and Evolution units feature an inbuilt mounting bracket for attaching the controls to the armrest of the tractor seat. An optional mounting kit (Part No. 22073.23) is available for Evolution control units if an alternative method of mounting is required.

The power supply cable should be connected directly to the tractors battery; do not use cigarette lighter type connections as these prove to be sporadic and unreliable for control applications. Control units are **12 volt DC** operated. The **brown lead is positive (+)**, the **blue lead is negative (-)**.

Electric Proportional Controls : v6 Mini-Revolution / v6 Revolution

Revolution proportional controls comprise of 2 units; the main control screen and the armrest control unit.

The control screen is supplied with a mounting bracket and suction cup assembly that allows the unit to be mounted on the window of the tractor cab; ensure the surface used is clean and dry and the unit mounted in a position where it does not obstruct operator vision.

The armrest unit is designed to slide over the armrest of the tractor seat and is held in place with the fixing straps provided. Alternately, the mounting bar of the controls can be used should a more permanent installation be required; when fitting the latter ensure that any holes drilled in the tractor cab are clear of any important components and/or electrical wiring and should not be located in any area where it could affect the safety structure of the cab or impede normal operation of machine or tractor.

The power supply cable should be connected directly to the tractors battery; do not use cigarette lighter type connections as these prove to be sporadic and unreliable for control applications. Control units are **12 volt DC** operated; the **red lead is positive (+)** and the **black lead is negative (-)**.

Operation of Control Units

Refer to the specific control manual supplied with the machine for operating instructions; users should read the controls operation manual in conjunction with the operation manual for the machine.

OPERATOR CONTROL SYSTEMS

Control System Operation Manual

For electrically controlled machines a dedicated operation manual for the specific control unit shipped with the machine is issued alongside this manual; **the control unit operation manual supplied must be read in conjunction with this manual** and should ideally be kept in the tractor cab for reference by the operator.

Control Unit Identification

Depending on specification the machine will be operated by one of the following controls;

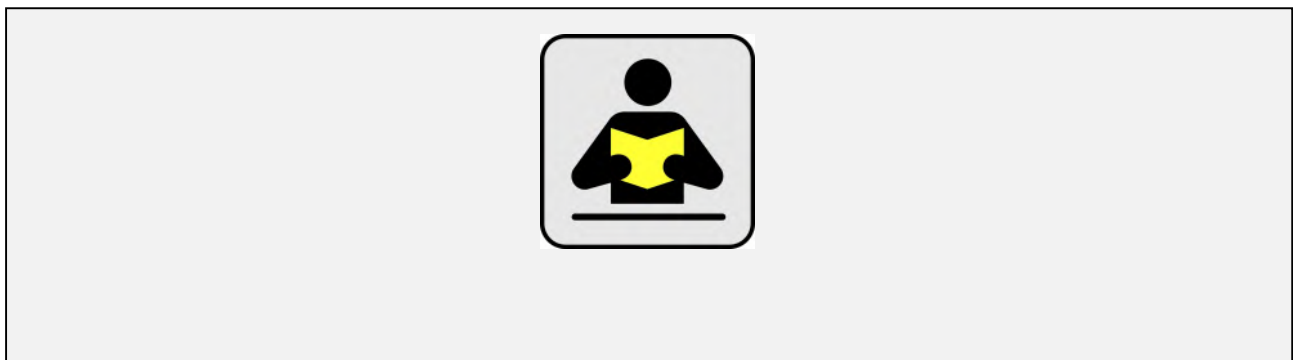
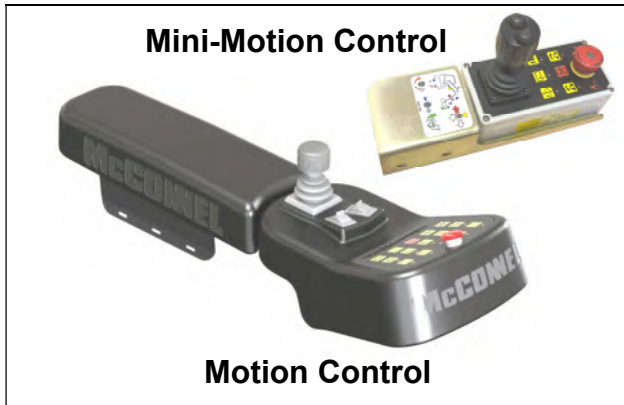

Control unit operation manuals are also available on our website for reference or download at; <https://www.mcconnel.com/support/parts-and-operators-manual/> or via QR code below.



RUNNING UP PROCEDURE

The running up procedure should be performed in a safe location clear of hazards. Keep bystanders at a safe distance at all times.

- Ensure lift ram lock tap is open and the transport strap has been removed and stowed in its work position before attempting to use the machine.
- Ensure that the rotor control is in the 'stop' position.
- Start tractor and engage the PTO, allow oil to circulate through the return line filter for approximately 5 minutes without any operation of the armhead controls.
- Operate armhead controls to move the arms through their complete range of movements ensuring that all are functioning correctly.
- Operate the machine carriage to ensure 'side to side' operation functions correctly.
- Place the flail head at a safe attitude and 'start' the rotor, after initial fluctuation the rotor should settle to a steady speed. Increase PTO speed to approximately 450RPM and run for a further 5 minutes before disengaging and stopping the tractor.
- Check the hose runs and ensure they are free from any pinching, chaffing, straining or kinks.
- Check oil level in the tank – top up if required.

EMERGENCY STOPPING

In all emergency situations machine operation and functions must be stopped immediately; **Stop PTO operation** using the tractor controls then immediately kill electrical power to the machine using the **Off (Emergency Stop)** switch on the machine's control unit.

WARNING: Auto-Reset Machines



When the Auto-Reset feature is active the machines arm set is capable of unintentional movement even when the PTO is switched off and stationary. Always ensure that electrical power to the machine is switched off using the **Off (Emergency Stop)** switch on the machine's control unit in emergency situations and/or when the machine is not being operated.

WARNING: Cable Operated Machines



In certain conditions, and/or if the Auto-Reset feature is active, the arm sets on cable operated machines possess the potential to move unintentionally, even when the PTO is switched off and stationary, if the levers were to be accidentally operated. Care must be adopted to avoid any movement of the levers when the machine is not being operated. Ensure arm sets are lowered fully to the ground when the machine is parked up or not in use.

TRANSPORTION

Transport Position

For transport of the machine the flailhead should be set parallel to the arms and the carriage moved to its furthest position on the tank side of the machine, the dipper arm can then be fully folded into the main arm and the latter positioned horizontally as illustrated below.

In this position the unit is both stable and compact, and in the case of front mounted machines will offer the driver maximum forward visibility during transportation.

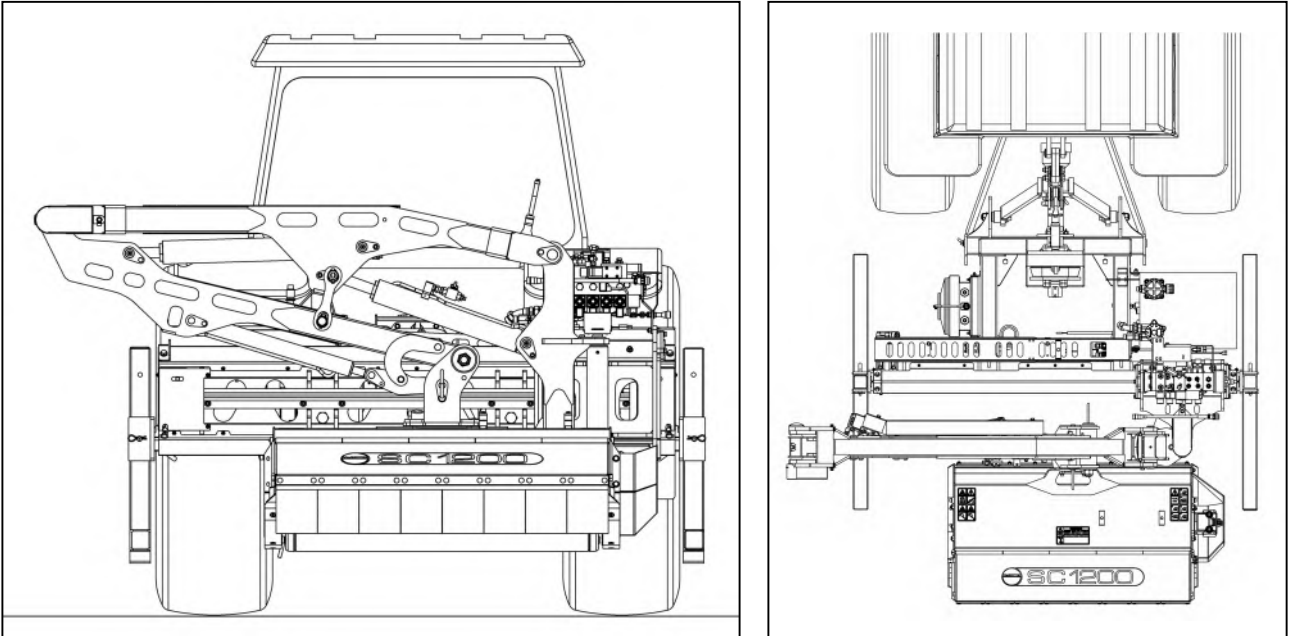

Transport Locks

The machine is equipped with two transport locking devices for securing the machine into the transport position; these are a lift ram lock tap and a transport strap. Both locking devices must be used at all times during transportation of the machine.

Work Position

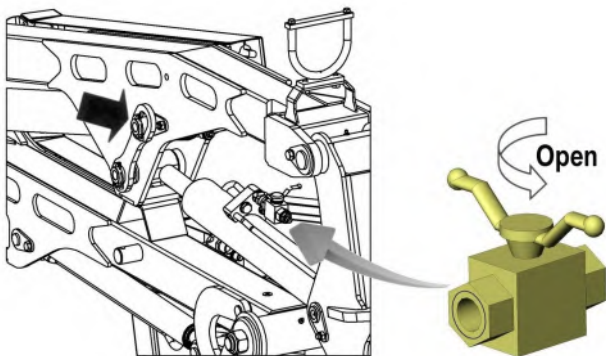

Transport Position

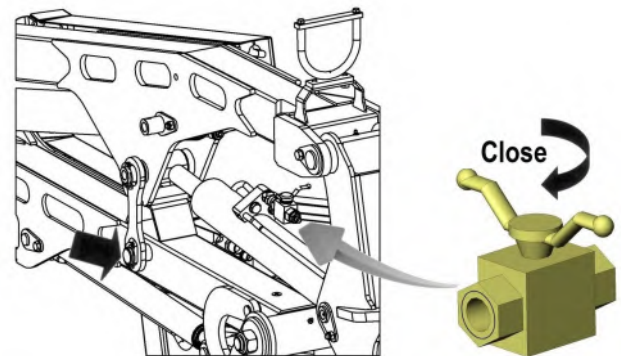

Transport Strap



For Work; Open the lift ram tap and place the transports strap in its stowing position on the main arm, secure in place with lynch pins.

For Transport; Close the lift ram tap and fit the transport strap in its 'brace' position to lock the dipper arm to the main arm, secure in place with lynch pins.



CAUTION: In transport the PTO must be disengaged, power to the controls switched off and all transport locking devices set to transport mode.

Moving into Transport

The procedure for moving the machine into the transport position is as follows;

- Operate 'slew' to align the arms parallel to the frame.
- Operate 'lift up' to fully raise the main arm.
- Operate 'reach in' to fully fold the dipper arm into the main arm.
- Operate 'carriage shift' to move the carriage to the tank side of the machine.
- Operate 'lift down' and 'angle' to bring the main arm and flailhead into the horizontal position.

Moving into Work

Moving from transport into work is basically a reversal of the above procedure. Always ensure when moving out of transport that 'lift' is the first control operated to ensure the flail head remains clear of the ground during subsequent movements.

Transport Height & Width

The design of this machine is such that when correctly folded its transport height will be below the height of the carrying vehicle.

The maximum width of the machine when correctly folded into its transport position is approximately 2.5m; in the majority of applications this will fall within the confines of the carrying vehicle.

During transportation the operator should always be aware of the machines dimensions and drive with due care and attention at all times.

Transport Speed

The acceptable speed whilst in transport will vary greatly depending on ground conditions; the maximum recommended speed is < 20mph. In all conditions avoid driving at speeds which cause exaggerated 'bouncing' as this will put unnecessary strain on both the tractor and machines components.

HORIZONTAL HEAD ROTATION – Manually Adjusted

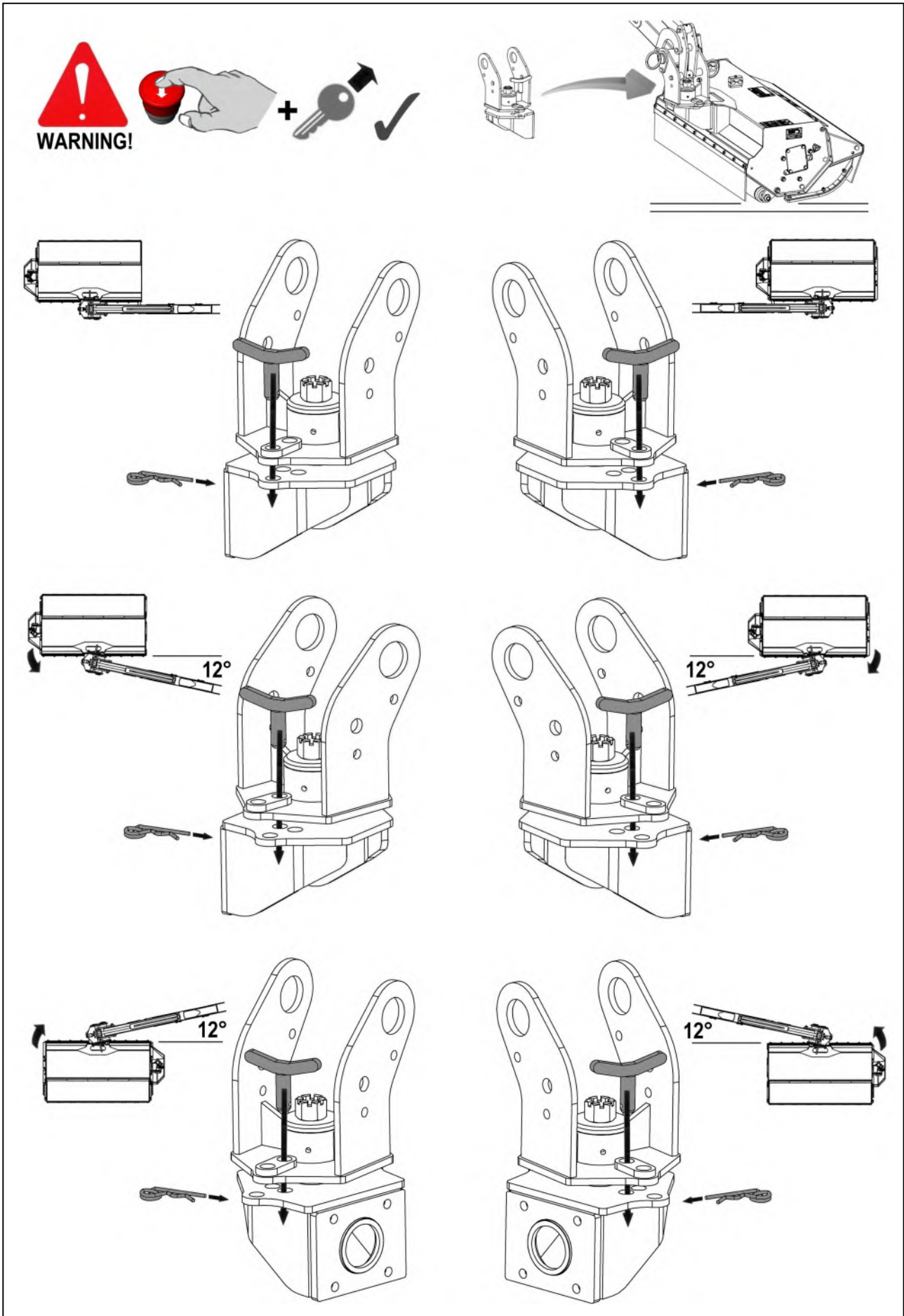

BREAKAWAY

The machine is fitted with a hydraulic breakaway device which protects the structure of the machine should an unforeseen fixed obstacle be encountered.

NOTE: The breakaway function does not relieve the operator of his responsibility to drive carefully, be alert and avoid obvious hazards before contact occurs.

Breakaway may occur momentarily during normal work should an extra thick or dense patch of vegetation be encountered. In these instances, tractor forward motion may be maintained with care.

Where breakaway has occurred as a result of contacting a post or tree etc. the tractor must be halted and the controls of the machine operated to manoeuvre the head away from the obstacle. **Never continue forward motion in an attempt to drag the head around the obstacle in the breakback position – serious damage can be caused to the machine.**

Note; the force required to activate the breakaway system will vary dependent upon the gradient of work. It will require less force when working uphill and vice versa.

CAUTION



Never work at a speed that fails to allow for sufficient stopping time in the event of breakback; it is the operators responsibility to ensure forward travel can be halted at any time before the machine reaches its breakback limit, failure to observe this can result in serious damage to the machine.

With 'Slew' Selected

When the slew relief valve setting is exceeded oil is displaced from the slew ram allowing the arm to pivot backwards horizontally and the obstacle to be cleared. Re-setting the head into the work position is carried out manually by selecting 'Slew Out' on the control assembly.

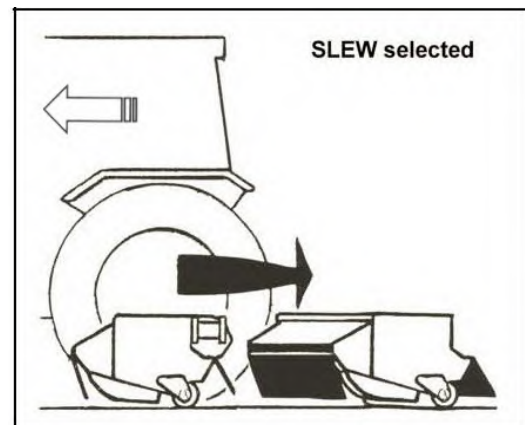

Note: Rear mounted machine illustrated ►

The design of the machine is such that with the full width carriage shift and 180° of normal slewing capability the manually rotatable flail head can be positioned to work on either side of the tractor or at any chosen position within the slewing arc; this feature is applicable to both front and rear mounted machines.

In order to offer protection to the machine in all possible work positions, the breakaway function will permit 20° of rearward arm movement irrespective of the particular travel direction; the only exception to this is when the operating front mounted machines with the arms positioned across the front of the machine where the available breakaway is reduced to 12°.

Breakaway Protection

The following illustrations show the breakback protection for various configurations of the machine fitted with the manual rotational head, the examples show the machines working at the pre-set 'slew stop' positions that set the machine at 90° to the tractor on each side, this is for normal work duty and allows for 20° of breakaway, the minimum required to ensure machine protection.

In the case of the front mounted machine shown with the arms and head positioned directly in front of the machine, it is positioned at the second 'slew stop' point which is pre-set at 12° forward; this will allow 12° of breakaway protection when working in this position.

Caution; always halt forward travel before the machine reaches its breakback limit.

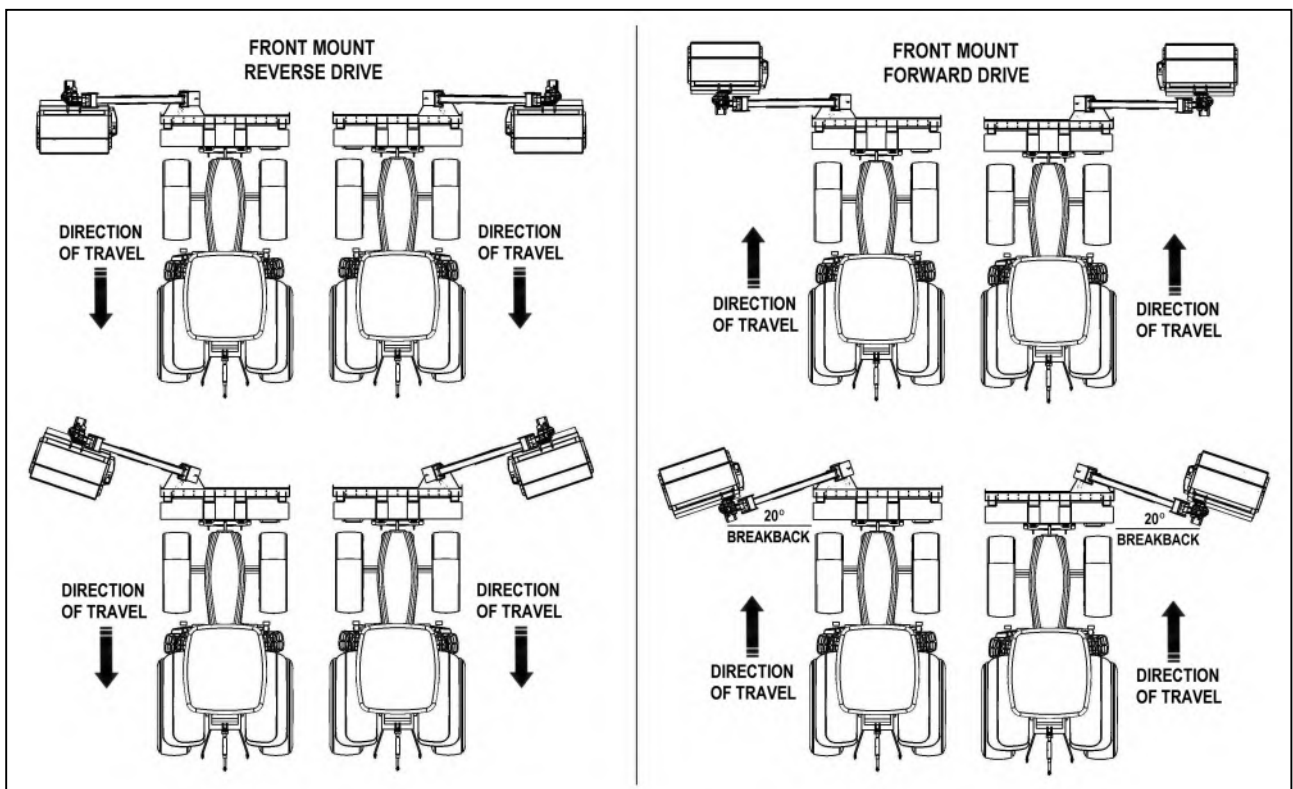
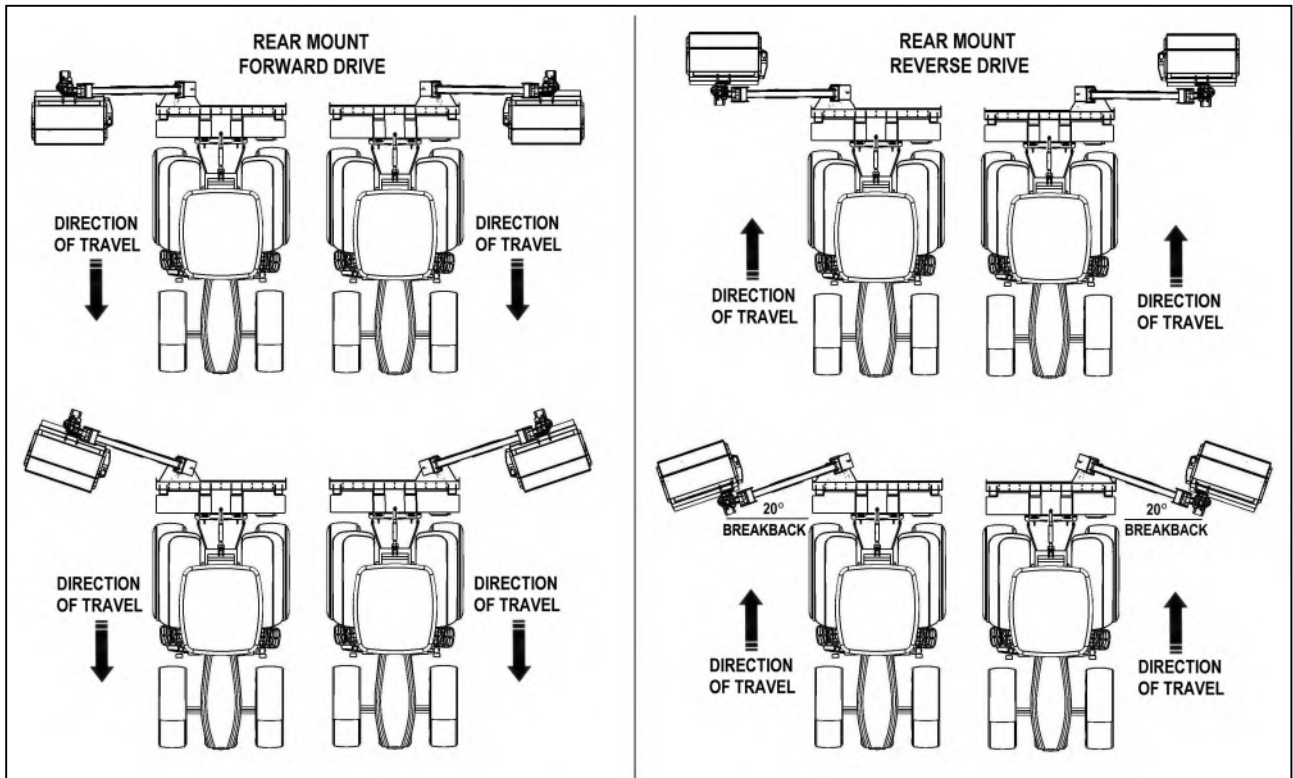

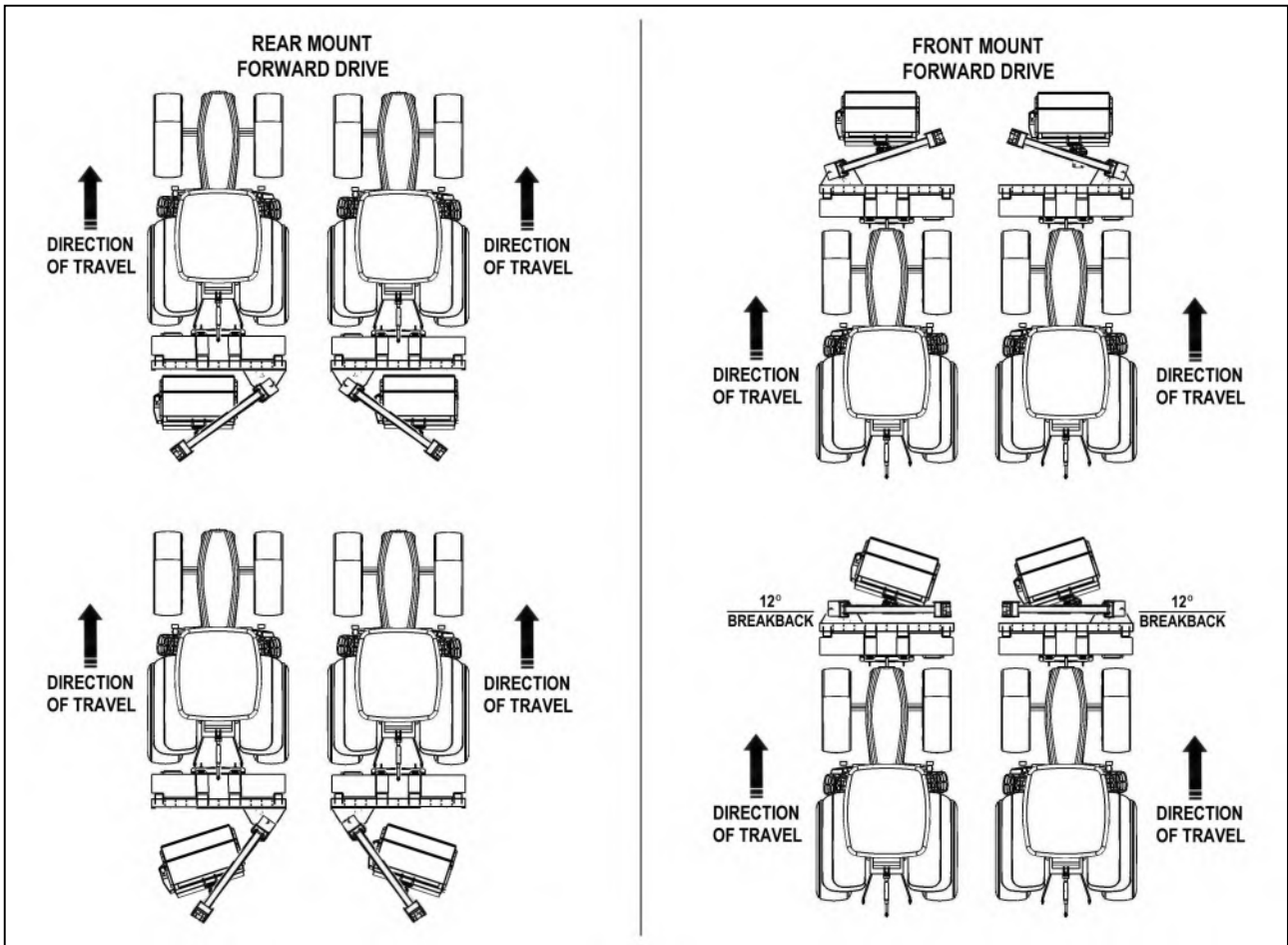

Powered Slew

The machine features 180° of powered slew which gives it the capability to work on either side of the tractor. The arms possess a further 20° of rearward movement on each side but this extra travel must be reserved for breakaway protection.

It is recommended for slewing that the dipper arm is positioned vertical with the head clear of the ground.

Slew Stops

Slew stop points are controlled electronically by sensors on the pillar that detect and measure the rotational slewing movements of the column.

The slew stop positions are factory pre-set at 90° to the tractor on both sides and at 12° forwards of those positions.

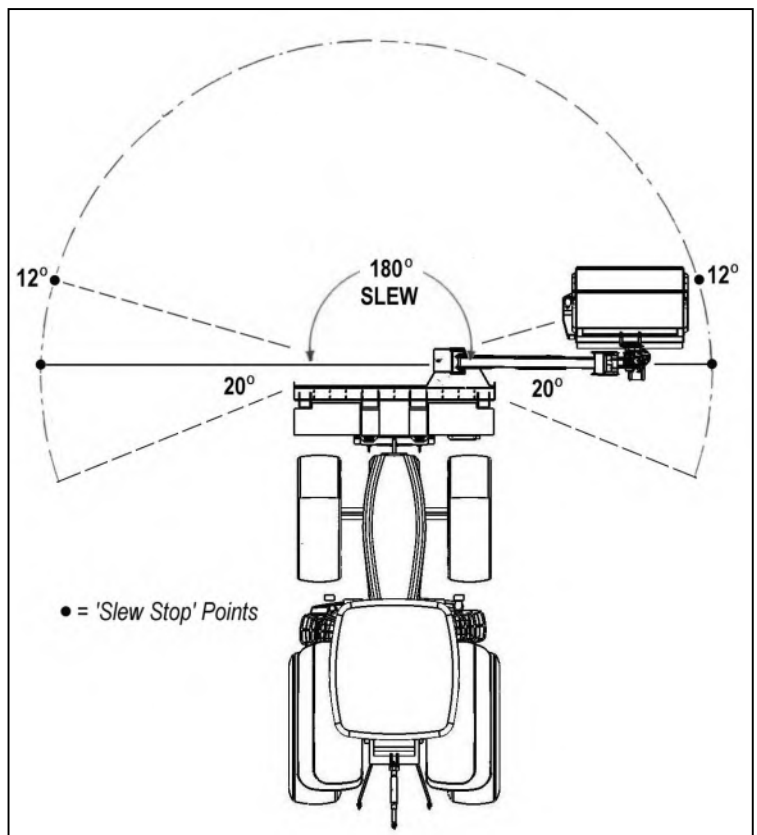

During slew operations, movement of the arm set will automatically stop on reaching a 'slew stop' point indicating that particular pre-set work position has been reached. To continue slewing the machines slew control must be re-operated.

EASY DRIVE SYSTEM (EDS)

The Easy Drive System (EDS) is an optional extra on proportional machines with 'Revolution' digital controls – where fitted it provides 'hands free' cruise control operation with automatic head and lift float at greater working speed that increase both safety and efficiency.

The system comprises of sensors that measure rotational movement of the rocker pin and pressure variations in the lift ram circuit these are processed and forwarded to the hydraulic system which then regulates the optimum lift ram pressure to allow the arm and head to 'float' over changing ground contours. With readings taken and processed every 30 milliseconds the lift ram pressure is constantly and rapidly re-evaluated and adjusted.

Any movement of the joystick in the lift plane will automatically de-activate EDS, on release of the joystick the system will immediately be reverted back to EDS mode - *This is particularly useful feature for manoeuvring the machine around obstructions.*

The EDS system has 3 user settings available for differing operating conditions – these are soft, medium and hard. For machines where EDS is installed refer to the specific control section for details of operation.

ANGLE FLOAT KIT (Standard Feature)

Machines are fitted with Angle Float as standard – when activated the feature connects the base and gland circuits of the angle ram to allow free movement of oil in both directions thus allowing the head to automatically angle itself to match the contours of the ground.

Refer to specific controls section for details of operation.

NOTE: On machines with 'Revolution' proportional controls any operation of the angle float thumbwheel will override and de-activate the automatic angle float function, on release of the thumbwheel it will revert back to automatic angle float.

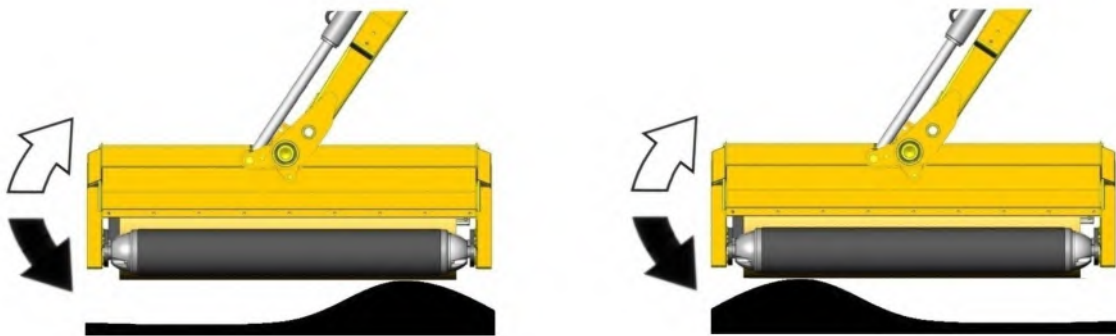

Angle Float Off – Requires operator input to adjust flail head angle

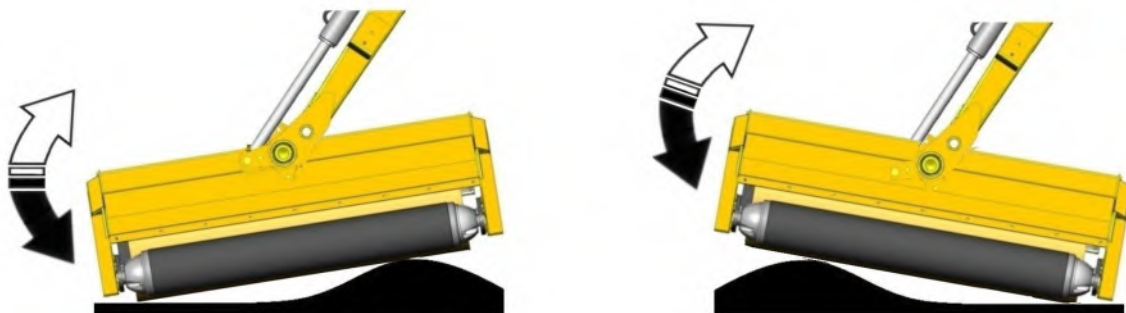

Angle Float On – Flail head automatically angles itself to match the ground contours.

LIFT FLOAT (Optional Extra for Ground Work)

Work without lift float requires far more concentration and input from the operator to quickly react and re-adjust to the ground contours often resulting in patches of higher cut material where the head is cutting too high and ‘scalping’ of the ground where it is cutting too low – *in the case of the latter this can lead to increased flail wear, damage or even loss of flails.*

The Lift float feature is an optional extra for use during mowing work. When the function is activated the pressurised accumulator(s) work in conjunction with the valve and lift ram to take a proportion of the flailheads weight off the flail roller allowing the head to automatically follow the natural contours of the ground; this produces a cleaner more uniform cut without the need for constant operator re-adjustment. On EDS models the function has 3 user settings for differing working conditions – these are soft, medium and hard. *Refer to the relevant control section for details of selecting the required setting.*

Operation of the lift float function is as follows: with lift float switched off, position the flailhead approximately 1m clear of the ground before switching the float function on to charge the accumulator(s) – *the arms may drop at this point depending on the current level of retained pressure.* Lower the flailhead into the work position, release the lift control and proceed to work. **NOTE:** *with the exception of EDS models, occasional operation of the lift function will be required when working on downhill or uphill slopes and when reaching in or out in order to replenish the oil level within the accumulator(s) to retain optimum float capability.*

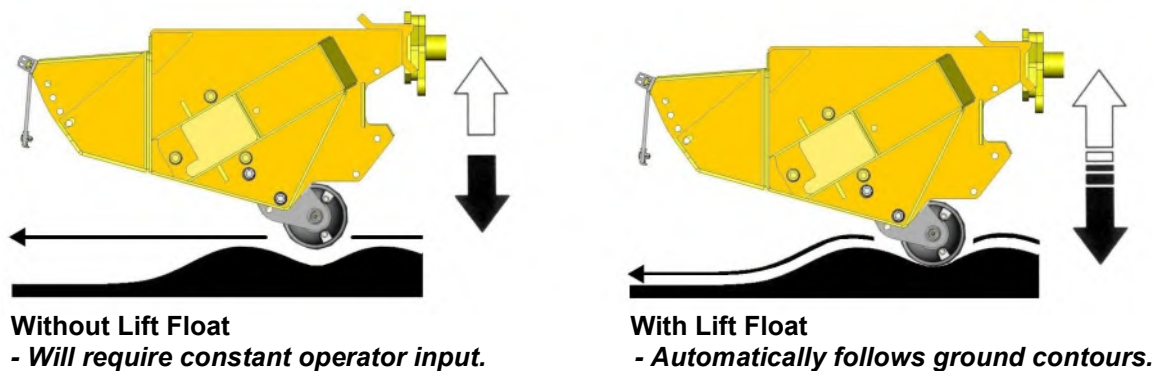

Lift float operation when supplied as a factory fitted option is controlled from the controls unit that accompanied the machine (*refer to controls section for details*), but the feature is also available for a range of models as an after market kit, in which case operation will either be via an auxiliary switch on cable controlled machines, or by utilisation of the auxiliary three-position type switch on the control unit of electric controlled machines - *this will allow for selection of ‘lift float alone’ or ‘lift and angle float in unison’ if both features are fitted.* Operation of the lift float control for these models will then be as specified in the main controls section.

Power Connections

On electric controlled machines power to the unit is via the following connections:

Machines with 14 core looms use connection 10 and common connection 11.

Machines with 19 core looms use connection 15 and common connection 16.

Non-EDS proportional machines use connections LF and C.

PRE-WORK PREPARATION & PRECAUTIONS

IMPORTANT: Always read the book first before attempting to operate the machine – practise operating the machine, without the rotor running, in a safe open space until you are fully familiar with all controls and functions of the machine. Only begin using the machine for work when you are confident that you have mastered the controls and operation sufficient for safe use of the machine.

CAUTION: Care must always be taken when working with the flailhead close in to avoid contact with the tractor.

Pre-work Machine Checks

Prior to use of the machine always check all bolts are tight and that the torque figures are correct for the specific locations indicated below:

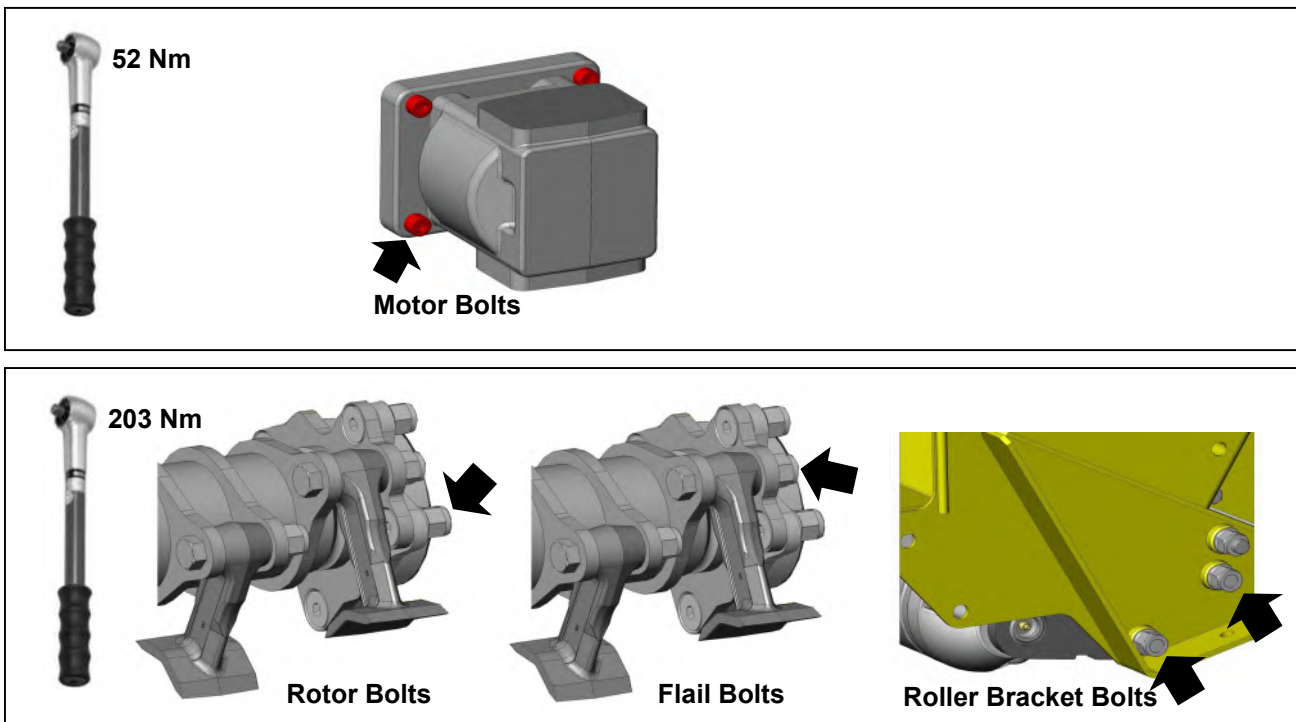

General Work Precautions

Inspect the work area prior to operation, remove any hazardous materials and note any immovable objects - *it may also be a wise precaution to mark these hazards with a visible marker than can be easily seen from the operating position in the tractor.*

If the type of work being undertaken makes this important precaution impractical, always maintain a high degree of alertness and restrict the tractor's forward motion to a speed that allows sufficient time to stop the tractor or avoid the hazard before contact is made.

General Working Practice

It is the operator's responsibility to develop safe working procedures;

Always:

- ▲ Be aware of potential hazards in the vicinity of the work area.
- ▲ Ensure all guards are fitted correctly and in good condition.
- ▲ Disengage PTO before stopping the engine.
- ▲ Wait until the flail has stopped running before leaving the tractor seat.
- ▲ Disengage the PTO, stop the engine, remove and pocket the key before making any adjustments to the machine.
- ▲ Check frequently that all nuts and bolts are tight.
- ▲ Keep bystanders at a safe distance.

OPERATING SPEED

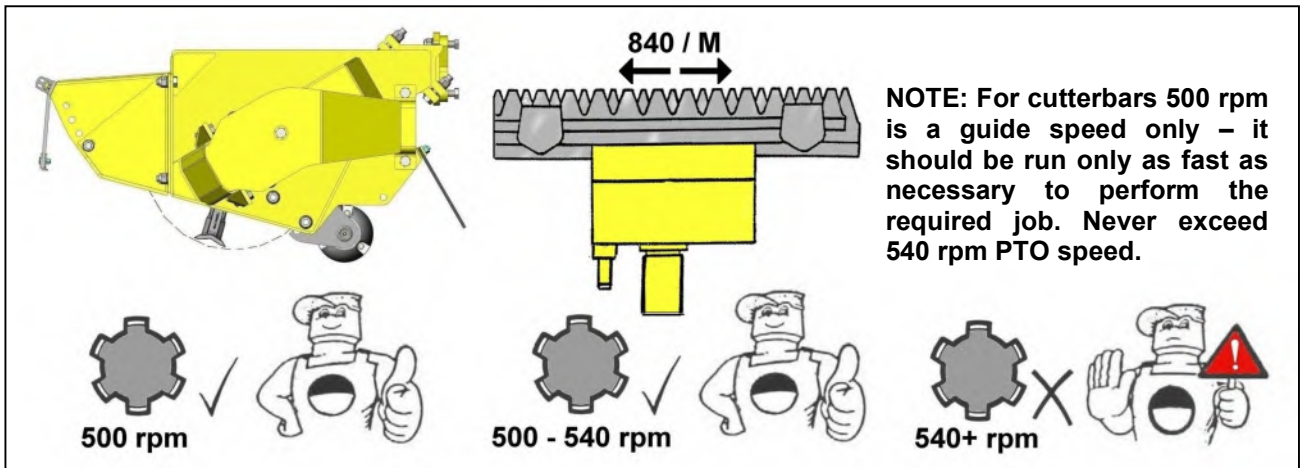

WARNING: Damage to the machine may occur if the maximum PTO speed is exceeded.

Engaging Drive

- ▲ Ensure the rotor control lever/switch is in the 'stop' position before engaging the PTO.
- ▲ Allow the oil to circulate for a minute or so before operating the armhead controls.
- ▲ Move the flail head into a safe working position just clear of the material to be cut.
- ▲ Increase engine speed to a high idle and start the rotor – after initial 'surging' the rotor will run at an even speed.
- ▲ Carefully lower the flail head into the work area and begin work.

Tractor Forward Speed (Mowing Work)

The material being cut will determine the tractor forward speed. Forward speed can be as fast as that which allows the flail head sufficient time to cut the vegetation both efficiently and neatly.

If forward speed is too fast this can be indicated by over frequent operation of the breakaway system, a fall off in tractor revs and a poor untidy finish to the work leaving ragged uncut tufts and poorly mulched cuttings.

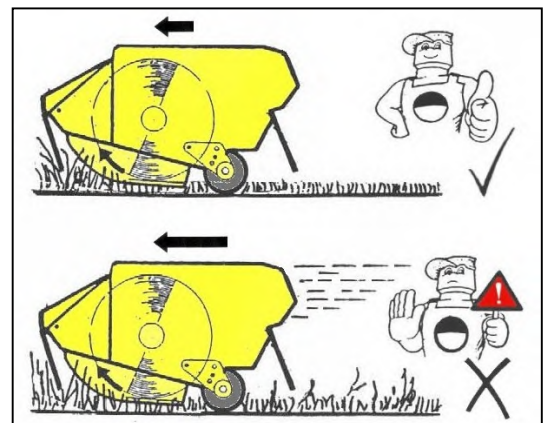

'Running In' a New Machine

For the first days work with a new machine it is recommended that tractor forward speed is restricted to 3 km/hr (2 mph) maximum. This will allow machine components 'bed in' and allow the operator to become familiar with the controls and their response under working conditions whilst operating at a relatively slow speed. If possible, select a first days work that affords mainly light to average cutting with occasional heavy duty work – *during this period check the tightness of nuts and bolts every hour, retightening as and when required.*

First day use - check tightness of nuts & bolts hourly ►

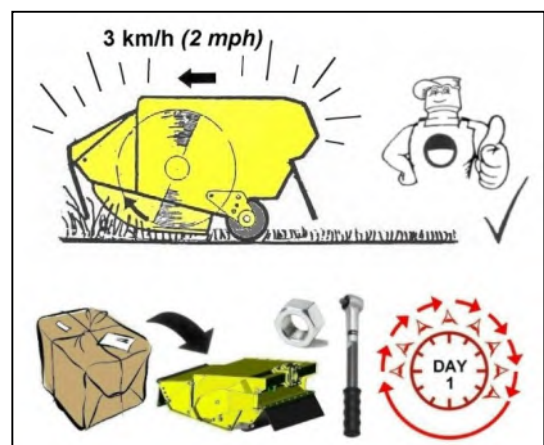

HEDGECUTTING PROCEDURE

Cut the side and bottom of the field side first. This leaves the maximum thickness of hedge on the road side to prevent the possibility of any debris being thrown through the hedge into the path of oncoming vehicles.

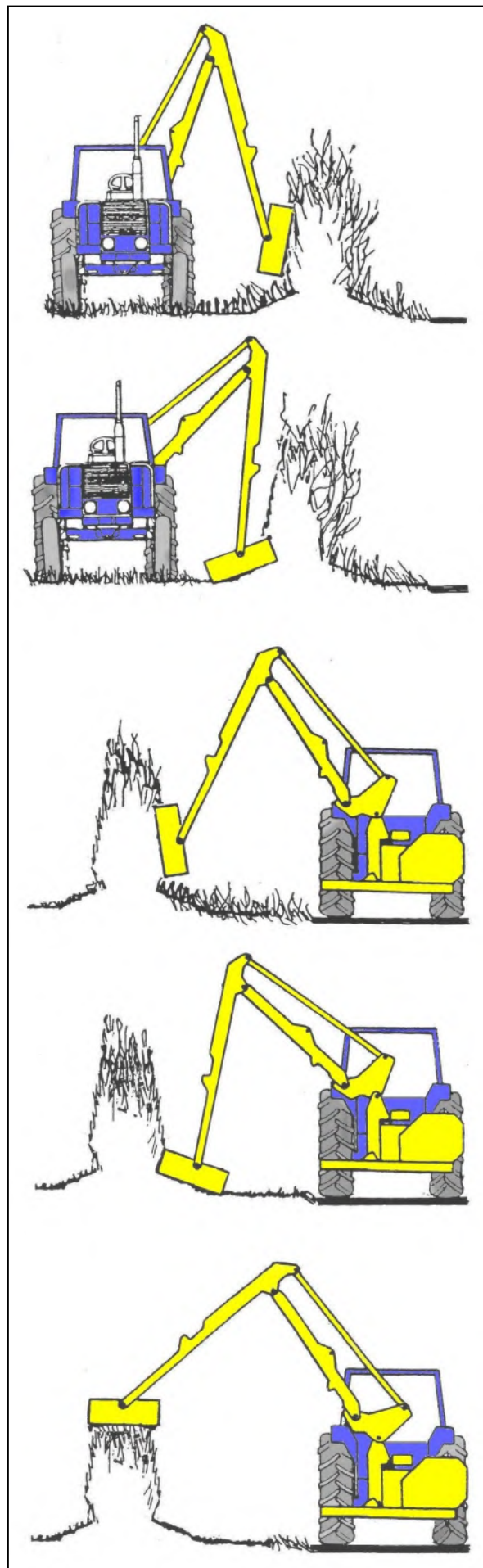

Cut the side and bottom of the road side.

Top cut the hedge to the height required.

HAZARDS & DANGERS

Adverse Slopes

When working with the flailhead high and reach fully in it is possible for the main arm balance to go over centre and take the weight off the lift ram. A restrictor in the gland circuit of the lift ram will prevent sudden unpredictable movements if this should occur - *for reasons of safety this restrictor should not be removed.*

DANGER!



NEVER REMOVE THE RESTRICTOR FROM THE LIFT RAM GLAND CIRCUIT.

Never work the machine on adverse slopes with the arms positioned such that the tractor is unbalanced ►

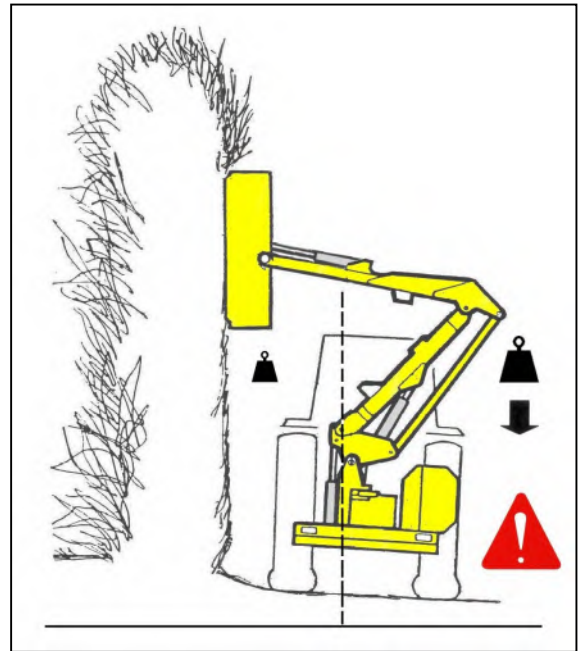

DANGER!



NEVER CUT TO THE BLIND SIDE OF A HEDGE
- it is impossible to see any potential hazards or dangers and the position of the flail head would allow debris to be propelled through the hedge towards the tractor and operator.

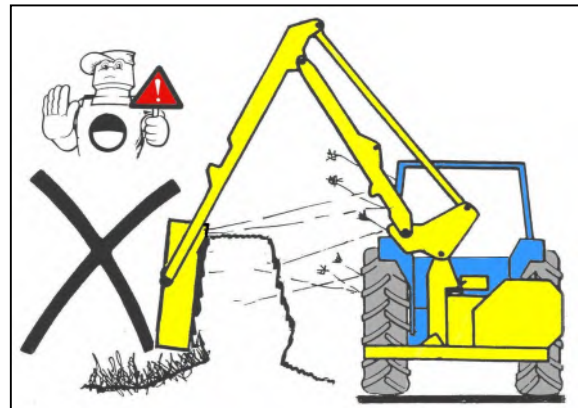

DANGER!



NEVER OPERATE THE MACHINE WITH THE FLAIL HEAD ROLLER REMOVED

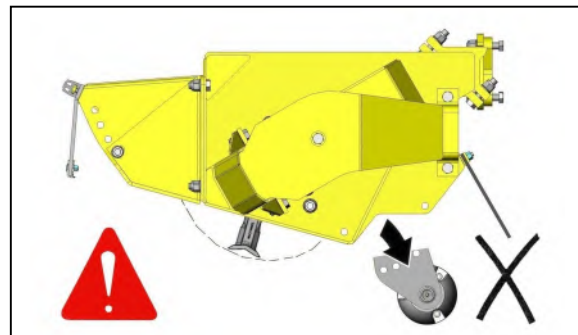

DANGER!



WHEN GRASS MOWING THE ROTOR MUST ALWAYS CUT IN THE UPHILL DIRECTION WITH FRONT HOOD FITTED AND THE ROLLER POSITIONED BELOW THE CUTTING HEIGHT OF THE FLAILS

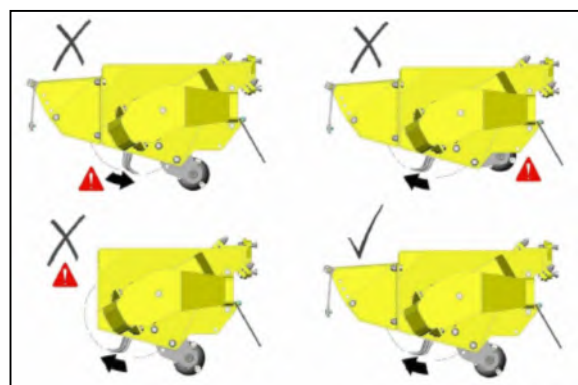

OVERHEAD POWER LINES (OHPLs)

It cannot be stressed enough the dangers involved when working in the vicinity of Overhead Power Lines (OHPLs). Some of our machines are capable of reach in excess of 8 metres (26'); they have the potential to well exceed, by possibly 3 metres (9' 9"), the lowest legal minimum height of 5.2 metres from the ground for 11,000 and 33,000 volt power lines.

Remember electrocution can occur without actually coming into contact with a power line as electricity can 'flashover' when machinery gets close to it.



WARNING: All operators must read the following information and be aware of the risks and dangers involved when working in the vicinity of Overhead Power Lines (OHPLs).

Wherever possible the safest option is always to avoid working in areas close to OHPLs. Where unavoidable, all operators must perform a risk assessment and implement a safe procedure and system of work – see *following page for details*. All operators should perform a risk assessment before operating the machine within 10m horizontal distance of any OHPLs.

Minimum Heights for Overhead Power Lines

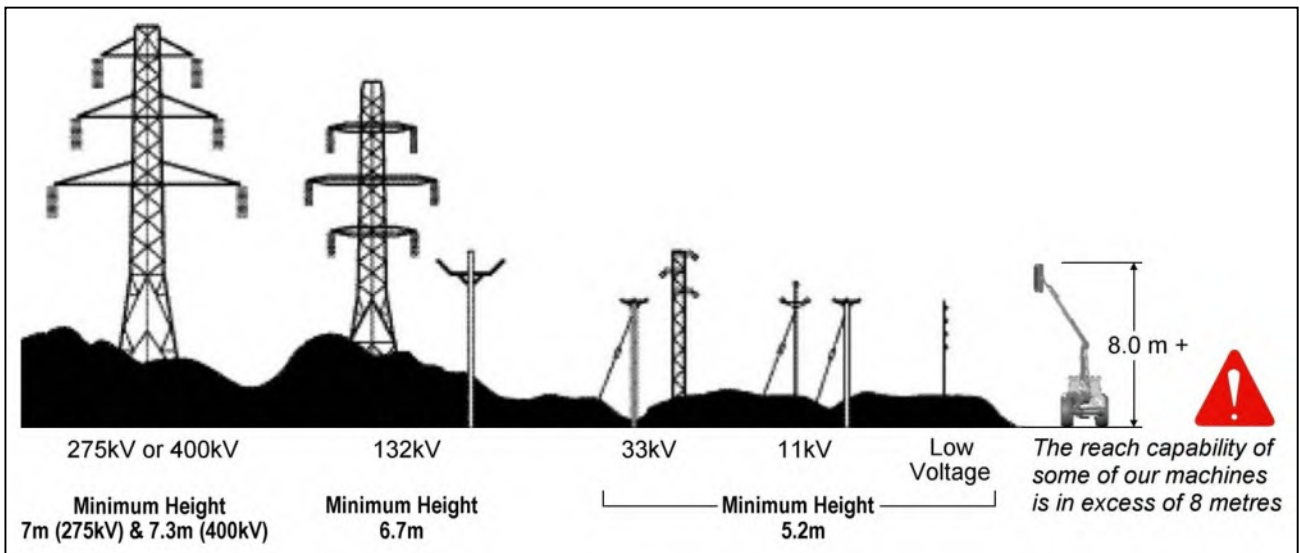

Absolute Minimum Exclusion Zones for Specific Overhead Power Lines

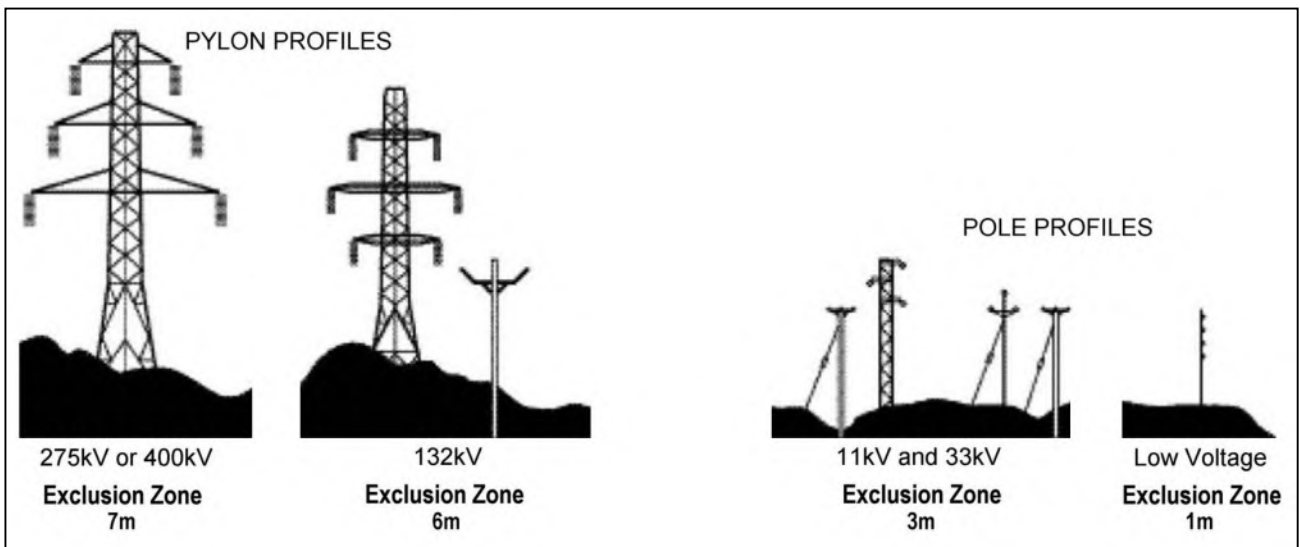

Definitions of Exclusion Zones

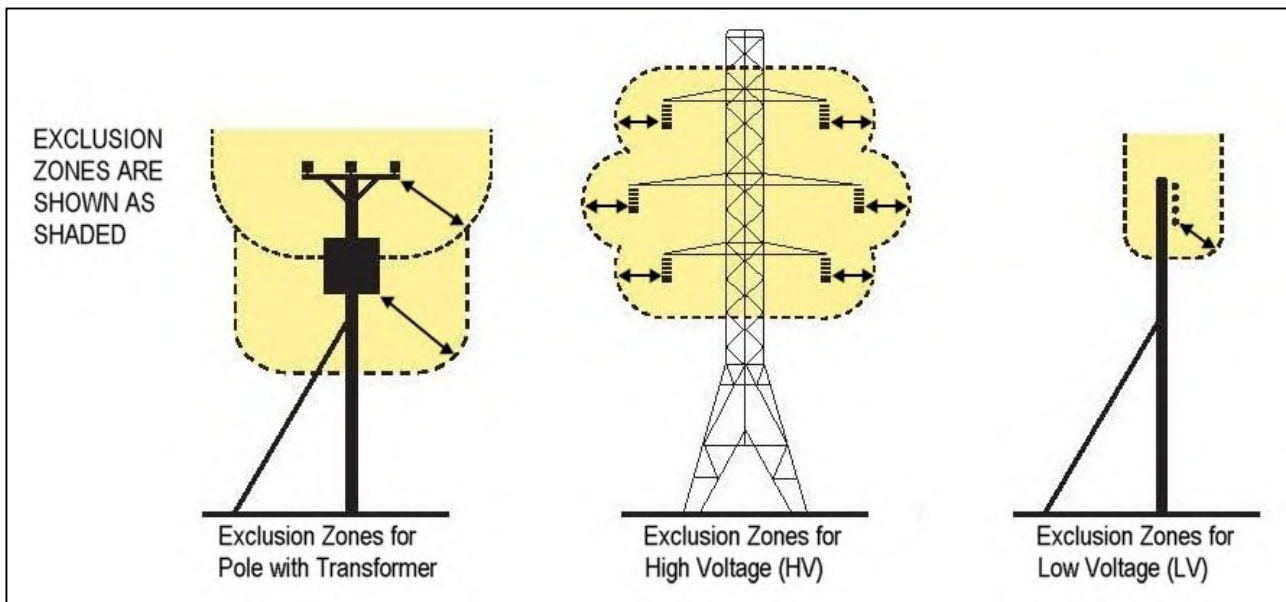

Risk Assessment

Before starting to work near OHPLs you should always assess the risks. The following points should be observed;

- ▲ **Know the risks** of contacting OHPLs and the risk of flashover.
- ▲ **Find out** the maximum height and maximum vertical reach of your machine.
- ▲ **Find out** the location and route of all Power Lines within the work area.
- ▲ **Find out** the operating voltage of all Power Lines within the work area.
- ▲ **Contact** the local Distribution Network Operator (DNO) who will be able to advise you on the operating voltage, safe minimum clearance distance for working, and additional precautions required.
- ▲ **Never** attempt to operate the machine in exclusion zones.
- ▲ **Always** work with extreme caution and plan your work ahead to avoid high risk areas.
- ▲ **If doubt exists** do not work in the area – never risk the safety of yourself or others.

Emergency Action for Accidents Involving Electricity

- Never touch an overhead line - even if it has been brought down by machinery, or has fallen. Never assume lines are dead.
- When a machine is in contact with an overhead line, electrocution is possible if anyone touches both the machine and the ground. Stay in the machine and lower any raised parts in contact or drive the machine out of the lines if you can.
- If you need to get out to summon help or because of fire, jump out as far as you can without touching any wires or the machine - keep upright and away.
- Get the electricity company to disconnect the supply. Even if the line appears dead, do not touch it - automatic switching may reconnect the power.

Further information and leaflets on this and other agricultural safety subjects are available on the 'Health & Safety Executive' website at the following address: www.hse.gov.uk/pubns/agindex.htm

FLAILS IDENTIFICATION

Grass Flails

Designed specifically for general mowing activities – low power usage, ideal for cutting materials of low density.

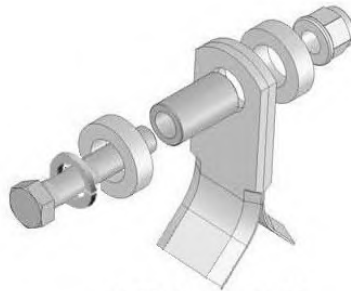

F10 Grass Flail
(Part No. 7190315)

Universal Boot Flails

Designed for general purpose work - suitable for mowing duties and the cutting of hedges with up to 2 years growth.

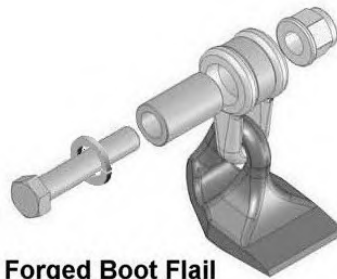

Forged Boot Flail
(Part No. 7190462)

Hedge Flails

Double edged flail designed specifically for heavy duty hedge cutting - capable of cutting materials up to 75/80mm diameter. Can be used for mowing work where they produce a good finish but will require considerably more power and reduced forward speed when used for this purpose.

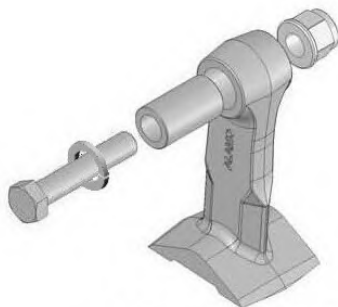

F10 D.E. Forged Flail
(Part No. 41391.02)



F10 D.E. Cast Flail
(Part No. 7314366D)

NOTE: Cast flails are more suitable where the work is predominantly hedge cutting as they maintain a sharper cutting edge – forged versions possess a higher degree of durability and are therefore more suitable where the primary function is mowing work and there is increased risk of hitting foreign objects.

Hedge Flails

Double edged flail designed specifically for heavy duty hedge cutting, capable of cutting materials up to 75/80mm diameter. Can be used for mowing work where they produce a good finish but will require considerably more power when used for this purpose. The flails are fitted with rubber stops for both shaft protection and noise reduction purposes.

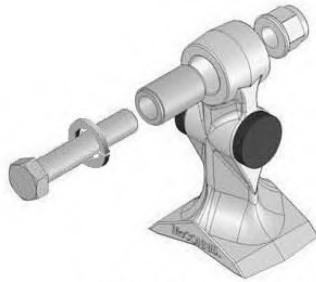

F16 D.E. Cast Flail
(Part No. 21904.02)

Competition Flails

Single edged flail designed specifically for heavy duty hedge and grass cutting, capable of dealing with materials up to 75/80mm diameter. When used for mowing work they produce a better finish and performance than double edged flails requiring less power and increased forward speed.

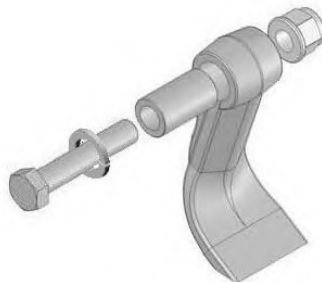

F10 S.E. Cast Flail
(Part No. 7390276)

Omega Flails

Double edged flail for use on 'Omega' rotors only - designed specifically for heavy duty hedge cutting where they are capable of cutting materials up to 75/80mm diameter. Unique rotor design allows the flail to rotate 360° on its pivot protecting the flail on impact with immovable objects. Not suitable for mowing work.

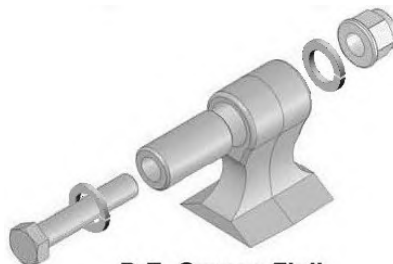

D.E. Omega Flail
(Part No. 7190464)

GENERAL MAINTENANCE

Machine Lubrication

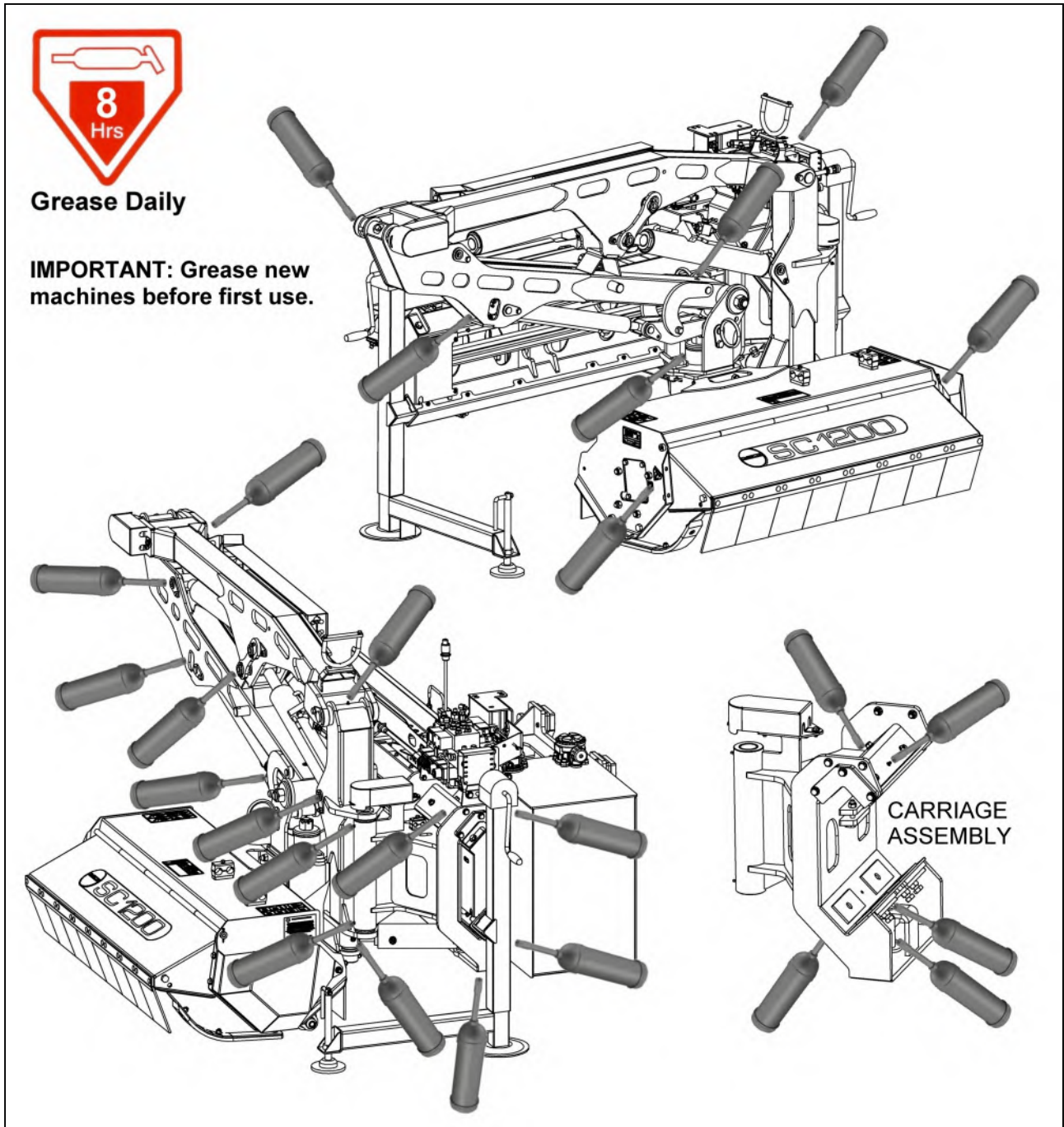

The illustrations above indicate the general locations of grease points; all grease points should be lubricated on a daily basis prior to work and prior to storage of the machine.

Gearbox Lubrication

Refill the gearbox after an initial 50 hours of use and thereafter at annual or 500 hour intervals, whichever occurs earliest.

Gearbox Oil Capacity & Type

1.0 Litre SAE75W90 Fully Synthetic which meets the following minimum requirements;

Viscosity at 40°C, cSt, 100.0 min.

Viscosity at 100°C, cSt, 17.2 min.

SERVICE SCHEDULE

| Every Day | |
|--|---|
| <ul style="list-style-type: none">• Grease machine fully prior to work (and prior to storage). NOTE: New machines must be fully greased before initial use.• Check for broken or damaged flails.• Check tightness of flail nuts and bolts.• Visually check for oil leaks and damaged hoses.• Check all guards and safety shields are correctly fitted and undamaged.• Ensure all lights are working and clean.• Check oil level.• Clean cooler matrix; in dusty conditions more frequent cleaning is required. |  |
| After initial 50-hours | |
| <ul style="list-style-type: none">• Change gearbox oil. | |
| Every 25-hours | |
| <ul style="list-style-type: none">• Grease PTO Shaft universal joints and tubes. | |
| Every Week | |
| <ul style="list-style-type: none">• Check tightness of all nuts and bolts.• Check gearbox oil level.• Check for wear on telescopic arm pads – <i>where applicable</i>. | |
| Every 100-hours | |
| <ul style="list-style-type: none">• Grease PTO shaft shield lubrication points.• Check bushes for wear; <i>wherever possible, remove end caps to allow inspection</i>. | |
| Every 500-hours | |
| <ul style="list-style-type: none">• Change return line filter element (<i>500-hours or annually, whichever occurs first</i>).• Change tank breather.• Change gearbox oil.• Check condition of hydraulic oil and change if required; <i>when changing the oil, new return line filter and suction strainer elements should be fitted and the return line filter changed again after 100 hours of work</i>. | |
| Annually | |
| <ul style="list-style-type: none">• Change tank breather. | |

Cooler Matrix

To ensure maximum cooler efficiency, the cooler matrix must be kept as clean as possible to allow free air flow through the unit; this is especially important in dry hot arduous conditions where the matrix can rapidly become blocked by dust causing overheating. Cooler units are best cleaned using a high-pressure air line that will clear blocked areas without risking damage to the matrix.

HYDRAULIC SYSTEM

Oil Supply

Check the oil level in the reservoir daily.

Oil Condition & Replacement

No fixed time period can be quoted for oil changes as operating conditions can vary widely but a visually inspection of the oil will often indicate its current overall state. Signs of a reduction in its condition will be apparent by changes in colour and appearance when compared to new oil. Oil in poor condition can be dark, smell rancid or burnt, or in some cases be yellow, unclear or milky in appearance indicating the presence of air or emulsified water. Moisture resulting from condensation can become entrapped in the oil causing emulsification that can block the return line filter, consequentially the filter system will be by-passed and the oil and any possible contaminants present will continue to circulate without filtration risking damage to hydraulic components. All are indications or conditions that will require replacement of the oil.

Hydraulic oil is a vital component of the machine; contaminated oil is the root cause of 70% of all hydraulic system failures. Contamination can be reduced by the following:

- Cleaning around the reservoir cap before removal, and keeping the tank area clean.
- Use of clean containers when replenishing the system.
- Regular servicing of the filtration system.

Filtration System

Machines are protected by both replaceable 125 micron suction strainers and low pressure 10 micron and 25 micron full flow return line filters – the diagram below is a ‘scaled up’ view illustrating the filtering capability built into the hydraulic system of the machine:

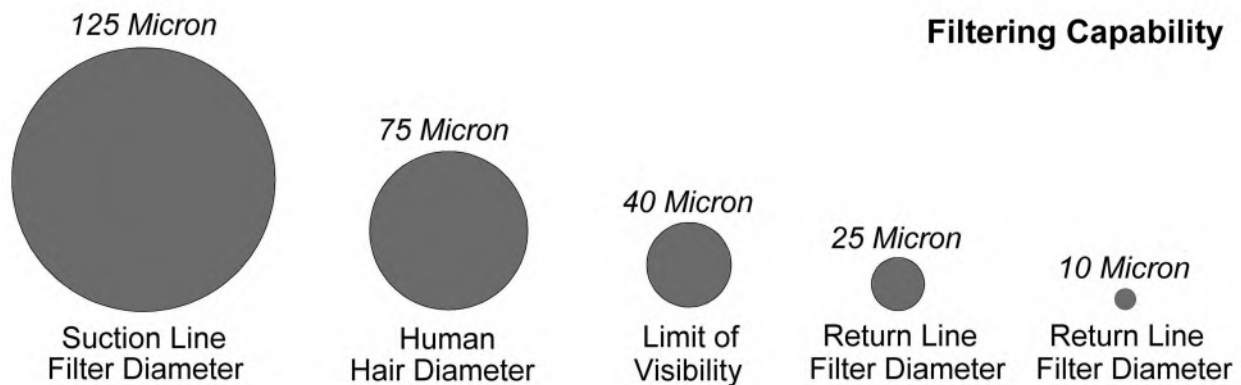

Suction strainers

The replaceable 125 micron suction strainers (*Part No. 8401097*) are fitted within the hydraulic tank and are ‘screw’ fitted with easy access for removal and replacement.

Suction Return & Return Line Filters

The machine is fitted with 2 return filters; a suction return with a 10 micron absolute filter element (*Part No. 8401129*), and a return line with a 25 micron absolute filter element (*Part No. 8401164*). These filters should be changed after the first 50 hours and thereafter at 500-hour intervals. It is important to note hours worked as if the filters becomes blocked an internal by-pass within the canisters will operate and no symptoms of filter malfunction will occur to jog your memory.

Tank Breather

To reduce the risk of pump cavitation it is advisable to replace the tank breather element (*Part No. 8401161*) on an annual basis under normal working conditions – for machines operating in dry dusty environments it is recommended that replacement be increased to 6 monthly.

HYDRAULIC HOSES

The condition of all hoses should be carefully checked during routine service of the machine. Hoses that have been chaffed or damaged on their outer casing should be securely wrapped with waterproof adhesive tape to stop the metal braid from rusting. Hoses that have suffered damage to the metal braid should be changed at the earliest opportunity.

Hose Replacement

- Replace one hose at a time to avoid the risk of wrong connections.
- When the hose is screwed to an additional fitting or union, use a second spanner on the union to avoid breaking both seals.
- Do not use jointing compound on the threads.
- Avoid twisting the hose. Adjust the hose line to ensure freedom from rubbing or trapping before tightening hose end connections.

Before changing hoses study the installation these are carefully calculated to prevent hose damage during operation. Always replace hoses in exactly the same manner. This is especially important for the flail hoses where they must be crossed, upper to lower, at the dipper and head pivots.

All BSP Hydraulic Hoses fitted to McConnel Power Arms have 'Soft Seal' connections on the flail circuit and ram circuit.

Recommended torque settings for nut security:

|  | Nut Size | Nm | Ft-lbs | O-Ring |
|---|----------|----|-----------------|-----------------|
| | 1/4" BSP | 24 | 18 | P/No. 10.000.01 |
| | 3/8" BSP | 33 | 24 | P/No. 10.000.02 |
| | 1/2" BSP | 44 | 35 | P/No. 10.000.03 |
| | 5/8" BSP | 58 | 43 | P/No. 10.000.04 |
| | 3/4" BSP | 84 | 62 | P/No. 10.000.05 |
| 1" BSP | 115 | 85 | P/No. 10.000.06 | |

Recommended torque settings for BSP hose unions fitted in conjunction with bonded seals:

|  | Union Size | Nm | Ft-lbs | Bonded Seal |
|---|------------|-----|---------------|---------------|
| | 1/4" BSP | 34 | 25 | P/No. 8650102 |
| | 3/8" BSP | 75 | 55 | P/No. 8650103 |
| | 1/2" BSP | 102 | 75 | P/No. 8650104 |
| | 5/8" BSP | 122 | 90 | P/No. 8650105 |
| | 3/4" BSP | 183 | 135 | P/No. 8650106 |
| 1" BSP | 203 | 150 | P/No. 8650108 | |

Safety Note

The soft seal hose connections are capable of holding pressure when the nut is only finger tight, it is therefore recommended when dismantling that the hose be manually flexed with the retaining nut slackened to relieve any residual pressure prior to complete disassembly.

FLAIL HEAD

Frequently inspect the rotor assembly for damaged or missing flails. Bolts and nuts securing the flails to the rotor should be regularly checked and kept tight. The correct torque setting for these locknuts is 135Nm (*100 lbf/ft.*). Use only the correct flail bolt and locking nut. Check the flail pivot bushes for possible damage or wear - they do not require oil.

Do not attempt to run the rotor with flails missing. Imbalance will cause severe vibration and can rapidly damage the rotor shaft bearings. As an emergency measure if a flail is broken off or lost, remove another on the opposite side of the rotor to retain balance. Always replace flails in opposite pairs and never match up a new flail with a re-sharpened one, which will of course be lighter.

Blunt flails absorb a lot of power and leave an untidy finish to the work. They should be sharpened on a grindstone or with a portable grinder periodically.

WARNING!

Wear protective gear when sharpening flails.

Ensure that the bearing housings and hydraulic mounting nuts and bolts are kept tight. They should be checked during servicing.

PTO SHAFT MAINTENANCE

PTO Shaft Lubrication

The PTO shaft should be lubricated on a regular basis using lithium based grease – each end of the shaft has 2 greasing points; one for lubrication of the universal joint and one for lubricating the rotating fixing ring of the shaft shield – access to the lubrication points is gained by releasing the shaft shield from its fixing ring and sliding it back along the body of the driveshaft – *the procedure and lubrication frequency is illustrated below.*



Shaft shield fixing clasps



Insert screwdrivers into the clasps



Pry clasps open to release the shield



Slide shield back to reveal universal joint

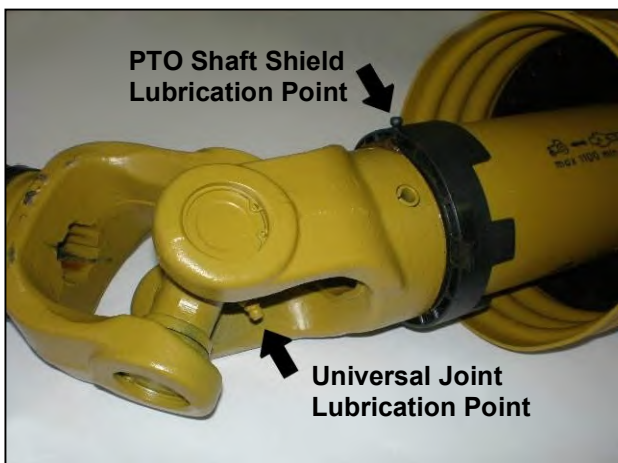

Location of lubrication points



Recommended lubricating frequency

Slide the shaft shield back into place after lubrication ensuring the clasps relocate correctly in the fixing ring – always fit torque chains to the shields to stop them from rotating with the shaft during operation.

TROUBLESHOOTING CHART

The chart below lists possible causes and solutions to problems that may be encountered.

| PROBLEM | POSSIBLE CAUSE | SOLUTION |
|-----------------------------|---------------------------------------|--|
| Gearbox overheating | Oil level incorrect | Check oil level |
| | Oil grade incorrect | Check oil grade |
| | Implement overloaded | Reduce forward speed |
| | Wrong PTO speed | Ensure tractor PTO speed matches implement |
| Excessive belt wear | Belt and pulley condition | Replace if necessary |
| | Pulley alignment | Check alignment |
| | Incorrect belt tension | Tension belts to spec |
| | Overloading of implement | Reduce forward speed or increase cut height |
| PTO wear / UJ failure | Working angle too great | Reduce mis-alignment of drive stub shafts |
| | Shaft length incorrect; bottoming out | Resize PTO shaft as recommended |
| | Lack of maintenance | Grease PTO shaft as recommended |
| Cut Quality | Flails worn or damaged | Replace worn/damaged flails |
| | Rotor speed / direction | Check rotor direction/tractor PTO speed |
| | Cutting conditions | Work in suitable cutting conditions |
| Rotor bearing failure | Rotor out of balance | Refer to rotor vibration below |
| | Wire / string in bearing | Remove wire / string |
| | Lack of maintenance | Grease bearings to schedule |
| | Moisture in bearing(s) | Grease bearing(s) to expel moisture |
| Rotor vibration | Flails broken or missing | Replace flails |
| | Bearings worn or damaged | Replace bearings |
| | Rotor unbalanced / bent | Re-balance / replace rotor |
| | Debris build up | Remove debris |
| | Incorrect speed | Check rotor RPM |
| Oil tank overheating | Oil level incorrect | Fill tank to correct level |
| | Oil grade incorrect | Drain and refill tank with correct grade oil |
| | PTO speed too fast | Match the tractor's PTO speed to machine |
| | Ambient temperature too high | Reduce work rate / install oil cooler |
| | Machine overloaded | Reduce forward speed or increase cut height |
| Frequent Break-back | Machine overloaded | Reduce forward speed or increase cut height |
| | Working on excessive incline | Disable auto-reset |
| | Machine weight sat on rear roller | Raise head or operate with head float |
| | Machine not set vertical | Adjust top link |
| | Internal valve leakage | Contact local dealer or McConnel Service |
| Hydraulics not responding | Oil level low | Fill oil to correct level |
| | Oil pump suction filter blocked | Replace filter element |
| | Oil leak in pressure line | Check machine for hydraulic leaks |
| | Drive line broken | Check pump is rotating |
| Irregular arm movement | Spool contacting with housing | Check spool moves freely |
| | Broken spring in spool valve | Check spring in spool valve |
| | Ram seal failure | Replace ram seals |
| Electric valve unresponsive | Faulty wiring | Check wiring and switches |
| | Dirt in valve | Check for ingress of dirt |
| | Sticking valve | Replace the valve |
| | Insufficient voltage | Ensure power is sourced direct from battery |



McConnel Limited, Temeside Works, Ludlow, Shropshire SY8 1JL. England.
Telephone: 01584 873131. Facsimile: 01584 876463. www.mcconnel.com