

Publication 800
January 2015
Part No. 23671.00
Revision: 08.11.17

McCONEL

PA3430 / PA4030 VERSI

FRONT MOUNT DUAL SIDED
HEDGE CUTTER / GRASS MOWER

Operator Manual

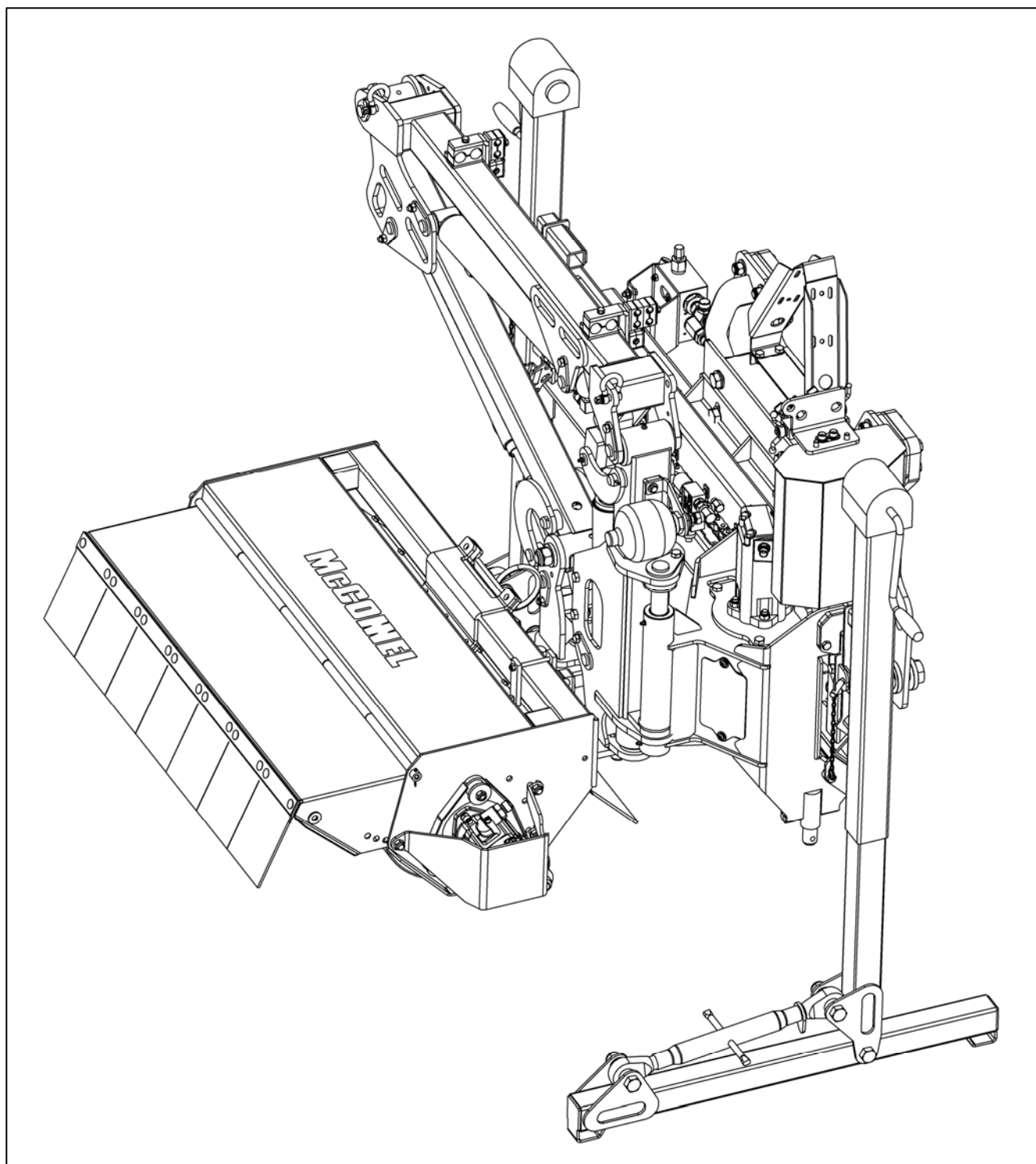

IMPORTANT

VERIFICATION OF WARRANTY REGISTRATION



Dealer Warranty Information & Registration Verification

It is imperative that the selling dealer registers this machine with McConnel Limited before delivery to the end user – failure to do so may affect the validity of the machine warranty.

To register machines; log onto <https://my.mcconnel.com> and select 'Machine Registration' which can be found in the 'Warranty' section of the site. **Confirm to the customer that the machine has been registered by completing the verification form below.**

Registration Verification	Serial No. <input type="text"/>
Dealer Name:	
Dealer Address:	
Customer Name:	
Date of Warranty Registration:/...../.....	Dealer Signature:

Note to Customer / Owner

Please ensure the section above has been completed and signed by the dealer to verify your machine has been registered with McConnel Limited.

IMPORTANT: During the initial 'bedding in' period of a new machine it is the customer's responsibility to regularly inspect all nuts, bolts and hose connections for tightness and re-tighten if required. New hydraulic connections occasionally weep small amounts of oil as the seals and joints settle in – where this occurs it can be cured by re-tightening the connection – *refer to torque settings chart below*. The tasks stated above should be performed on an hourly basis during the first day of work and at least daily thereafter as part of the machine's general maintenance procedure.

CAUTION: DO NOT OVER TORQUE HYDRAULIC FITTINGS AND HOSES

Torque Settings for Hydraulic Fittings

Hydraulic Hose Ends		
BSP	Setting	Metric
1/4"	18 Nm	19 mm
3/8"	31 Nm	22 mm
1/2"	49 Nm	27 mm
5/8"	60 Nm	30 mm
3/4"	80 Nm	32 mm
1"	125 Nm	41 mm
1.1/4"	190 Nm	50 mm
1.1/2"	250 Nm	55 mm
2"	420 Nm	70 mm

Port Adaptors with Bonded Seals		
BSP	Setting	Metric
1/4"	34 Nm	19 mm
3/8"	47 Nm	22 mm
1/2"	102 Nm	27 mm
5/8"	122 Nm	30 mm
3/4"	149 Nm	32 mm
1"	203 Nm	41 mm
1.1/4"	305 Nm	50 mm
1.1/2"	305 Nm	55 mm
2"	400 Nm	70 mm

WARRANTY POLICY

WARRANTY REGISTRATION

All machines must be registered, by the selling dealer with McConnel Ltd, before delivery to the end user. On receipt of the goods it is the buyer's responsibility to check that the Verification of Warranty Registration in the Operator's Manual has been completed by the selling dealer.

1. LIMITED WARRANTIES

- 1.01. *All mounted machines supplied by McConnel Ltd are warranted to be free from defects in material and workmanship from the date of sale to the original purchaser for a period of 12 months, unless a different period is specified.
All Self Propelled Machines supplied by McConnel Ltd are warranted to be free from defects in material and workmanship from the date of sale to the original purchaser for a period of 12 months or 1500 hours. Engine warranty will be specific to the Manufacturer of that unit.*
- 1.02. *All spare parts supplied by McConnel Ltd and purchased by the end user are warranted to be free from defects in material and workmanship from the date of sale to the original purchaser for a period of 6 months. All parts warranty claims must be supported by a copy of the failed part invoice to the end user. We cannot consider claims for which sales invoices are not available.*
- 1.03. *The warranty offered by McConnel Ltd is limited to the making good by repair or replacement for the purchaser any part or parts found, upon examination at its factory, to be defective under normal use and service due to defects in material or workmanship. Returned parts must be complete and unexamined. Pack the component(s) carefully so that any transit damage is avoided. All ports on hydraulic items should be drained of oil and securely plugged to prevent seepage and foreign body ingress. Certain other components, electrical items for example, may require particular care when packing to avoid damage in transit.*
- 1.04. *This warranty does not extend to any product from which McConnel Ltd's serial number plate has been removed or altered.*
- 1.05. *The warranty policy is valid for machines registered in line with the terms and conditions detailed and on the basis that the machines do not extend a period of 24 months or greater since their original purchase date, that is the original invoice date from McConnel Limited.
Machines that are held in stock for more than 24 months cannot be registered for warranty.*
- 1.06. *This warranty does not apply to any part of the goods, which has been subjected to improper or abnormal use, negligence, alteration, modification, fitment of non-genuine parts, accident damage, or damage resulting from contact with overhead power lines, damage caused by foreign objects (e.g. stones, iron, material other than vegetation), failure due to lack of maintenance, use of incorrect oil or lubricants, contamination of the oil, or which has served its normal life. This warranty does not apply to any expendable items such as blades, belts, clutch linings, filter elements, flails, flap kits, skids, soil engaging parts, shields, guards, wear pads, pneumatic tyres or tracks.*
- 1.07. *Temporary repairs and consequential loss - i.e. oil, downtime and associated parts are specifically excluded from the warranty.*
- 1.08. *Warranty on hoses is limited to 12 months and does not include hoses which have suffered external damage. Only complete hoses may be returned under warranty, any which have been cut or repaired will be rejected.*
- 1.09. *Machines must be repaired immediately a problem arises. Continued use of the machine after a problem has occurred can result in further component failures, for which McConnel Ltd cannot be held liable, and may have safety implications.*
- 1.10. *If in exceptional circumstances a non McConnel Ltd part is used to effect a repair, warranty reimbursement will be at no more than McConnel Ltd's standard dealer cost for the genuine part.*

- 1.11. *Except as provided herein, no employee, agent, dealer or other person is authorised to give any warranties of any nature on behalf of McConnell Ltd.*
- 1.12. *For machine warranty periods in excess of 12 months the following additional exclusions shall apply:*
 - 1.12.1. *Hoses, exposed pipes and hydraulic tank breathers.*
 - 1.12.2. *Filters.*
 - 1.12.3. *Rubber mountings.*
 - 1.12.4. *External electric wiring.*
 - 1.12.5. *Bearings and seals*
 - 1.12.6. *External Cables, Linkages*
 - 1.12.7. *Loose/Corroded Connections, Light Units, LED's*
 - 1.12.8. *Comfort items such as Operator Seat, Ventilation, Audio Equipment*
- 1.13. *All service work, particularly filter changes, must be carried out in accordance with the manufacturer's service schedule. Failure to comply will invalidate the warranty. In the event of a claim, proof of the service work being carried out may be required.*
- 1.14. *Repeat or additional repairs resulting from incorrect diagnosis or poor quality previous repair work are excluded from warranty.*

NB Warranty cover will be invalid if any non-genuine parts have been fitted or used. Use of non-genuine parts may seriously affect the machine's performance and safety. McConnell Ltd cannot be held responsible for any failures or safety implications that arise due to the use of non-genuine parts.

2. REMEDIES AND PROCEDURES

- 2.01. *The warranty is not effective unless the Selling Dealer registers the machine, via the McConnell web site and confirms the registration to the purchaser by completing the confirmation form in the operator's manual.*
- 2.02. *Any fault must be reported to an authorised McConnell Ltd dealer as soon as it occurs. Continued use of a machine, after a fault has occurred, can result in further component failure for which McConnell Ltd cannot be held liable.*
- 2.03. *Repairs should be undertaken within two days of the failure. Claims submitted for repairs undertaken more than 2 weeks after a failure has occurred, or 2 days after the parts were supplied will be rejected, unless the delay has been authorised by McConnell Ltd. Please note that failure by the customer to release the machine for repair will not be accepted as a reason for delay in repair or submitting warranty claims.*
- 2.04. *All claims must be submitted, by an authorised McConnell Ltd Service Dealer, within 30 days of the date of repair.*
- 2.05. *Following examination of the claim and parts, McConnell Ltd will pay, at their discretion, for any valid claim the invoiced cost of any parts supplied by McConnell Ltd and appropriate labour and mileage allowances if applicable.*
- 2.06. *The submission of a claim is not a guarantee of payment.*
- 2.07. *Any decision reached by McConnell Ltd. is final.*

3. LIMITATION OF LIABILITY

- 3.01. *McConnell Ltd disclaims any express (except as set forth herein) and implied warranties with respect to the goods including, but not limited to, merchantability and fitness for a particular purpose.*
- 3.02. *McConnell Ltd makes no warranty as to the design, capability, capacity or suitability for use of the goods.*
- 3.03. *Except as provided herein, McConnell Ltd shall have no liability or responsibility to the purchaser or any other person or entity with respect to any liability, loss, or damage caused or alleged to be caused directly or indirectly by the goods including, but not limited to, any indirect, special, consequential, or incidental damages resulting from the use or operation of the goods or any breach of this warranty. Notwithstanding the above limitations and warranties, the manufacturer's liability hereunder for damages incurred by the purchaser or others shall not exceed the price of the goods.*
- 3.04. *No action arising out of any claimed breach of this warranty or transactions under this warranty may be brought more than one (1) year after the cause of the action has occurred.*

4. MISCELLANEOUS

- 4.01. McConnel Ltd may waive compliance with any of the terms of this limited warranty, but no waiver of any terms shall be deemed to be a waiver of any other term.*
- 4.02. If any provision of this limited warranty shall violate any applicable law and is held to be unenforceable, then the invalidity of such provision shall not invalidate any other provisions herein.*
- 4.03. Applicable law may provide rights and benefits to the purchaser in addition to those provided herein.*

McConnel Limited

POWER ARM & TRACTOR PRE-OPERATION INSPECTION

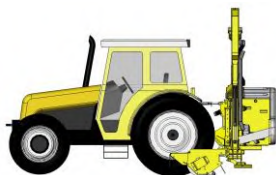

A daily equipment inspection of machine and tractor should be conducted before the equipment is used.

Use the inspection sheets on the following pages to assist with these daily inspections. Damaged or missing guards should be repaired or replaced before operating the mower. Failure to repair or replace damaged guards can result in objects being thrown from the mower and possibly hitting the operator and/or bystanders.

Inspect the Mower for Safe Operating Condition

- Make sure the driveline guards and shielding are in place and in good repair.
- Inspect the flexible thrown object shielding to assure that they are in place on the front and rear of the mower head and in good repair. Repair or replace any damaged or missing thrown object shields.
- Ensure the mower cutting height is set high enough to reduce the possibility of the mower blades contacting the ground. Actual height will be dependent on the ground conditions. Increase the height when working in rough or undulating conditions.
- Inspect for broken, chipped, bent, missing, or severely worn blades. Replace damaged blades before operating the mower. Ensure the blade retaining bolts and fasteners are secure and tight.
- Ensure all head bolts and nuts are tight.
- Lubricate the driveline universal joints and telescoping members daily.
- Grease the rotor and roller bearings and inspect their condition.
- Inspect for any oil leaks or damaged hoses.
- Inspect for worn and/or damaged decals and safety instructions. Replace unreadable, damaged or missing safety decals.
- Follow the operator's manual(s) inspection and maintenance instructions for lubricating parts, and keeping thrown object shielding, driveline guards, rotating parts shields, mower blades, and decals in good repair.

Inspect the Tractor for Safe Operating Condition

- Inspect the controls, lights, SMV's (Slow Moving Vehicle sign), seat belts, and ROPS to ensure they are in place and in good working order.
- Ensure tyres, wheels, lug bolts/nuts are in good condition.
- Make sure the tractor brakes and steering are in proper operating condition.
- Follow the operator's manual(s) inspection and maintenance procedures for keeping the tractor in good and safe condition before operating.

Copies of the inspection sheets on the following pages should be retained in this manual for reference; two sets are included to allow removal of one set for photocopying purposes. Alternatively, these inspection sheets can be download from our website via the QR code or using the link below;
<https://my.mcconnel.com/service/pre-operation-inspection-documents/>





POWER ARM PRE-OPERATION INSPECTION



Power Arm ID Date: Shift:



WARNING: Before conducting the inspection, make sure the tractor engine is off, the key removed, all rotation has stopped and the tractor is in park with the parking brake engaged. Make sure the mower head is resting on the ground or is securely blocked up and supported and all hydraulic pressure has been relieved.

Item	Condition at start of shift	Specific Comments if not O.K.
The operator's manual is in the canister on the mower.		
All warning decals are in place, clean and legible.		
All lights are clean and working.		
The mounting frame bolts are in place and tight.		
The arm pivot pins are tight and correctly secured.		
There are no cracks in the arms.		
Hydraulic cylinder pins are tight and correctly secured.		
Hydraulic cylinder hose connections are tight.		
Hydraulic pump hose connections are tight.		
Hydraulic valve hose connections are tight.		
Hydraulic valve controls function properly.		
There are no damaged hoses.		
The oil level is to the green mark on the tank sight glass.		
There is no evidence of hydraulic oil leaks.		
Flails are not missing, chipped, broken or excessively worn.		
The flail bolts are tight.		
The front and rear flaps are fitted and in good condition.		
The front hood is in place and in good condition.		
The wire trap is in good condition.		
The skid shoes are in good condition and tight.		
There are no cracks or holes in flail casing.		
Hydraulic motor mounting bolts are tight.		
All flail head nuts and bolts are tight.		
The rotor bearings are in good condition and greased.		
The roller bearings are in good condition and greased.		
The drive line shaft guard is in good condition.		
The drive line shaft guard is correctly secured.		
Controls are securely mounted in the cab.		
With engine running check arm operation.		
Have a spare pack of flails, bushes, bolts and nuts.		

Operators Signature:

DO NOT OPERATE AN UNSAFE TRACTOR OR MACHINE



TRACTOR PRE-OPERATION INSPECTION



Power Arm ID Date: Shift:



WARNING: Before conducting the inspection, make sure the tractor engine is off, the key removed, all rotation has stopped and the tractor is in park with the parking brake engaged. Ensure any implement attached to the tractor is firmly on the ground.

Item	Condition at start of shift	Specific Comments if not O.K.
The flashing lights function properly.		
All lights are clean and working correctly.		
All cab windows are clean and wipers working correctly.		
The SMV sign, where required, is clean and visible.		
The tyres are in good condition with correct pressure.		
The wheel nuts are tight.		
The tractor brakes are in good condition.		
The steering linkage is in good condition.		
There are no visible oil leaks.		
The hydraulic controls function properly.		
The ROPS or ROPS cab is in good condition.		
The seatbelt is in place and in good condition.		
The 3-point hitch is in good condition.		
The drawbar/pick up hook is secure and in good condition.		
The PTO master shield is in place.		
The engine oil level is full.		
The brake fluid level is full.		
The power steering fluid level is full.		
The fuel level is adequate.		
The engine coolant fluid level is full.		
The radiator and oil cooler are free of debris.		
The air filter is in good condition.		

Operators Signature:

DO NOT OPERATE AN UNSAFE TRACTOR OR MACHINE



POWER ARM PRE-OPERATION INSPECTION

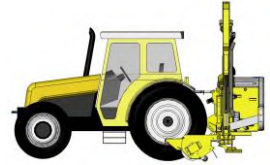

Power Arm ID Date: Shift:



WARNING: Before conducting the inspection, make sure the tractor engine is off, the key removed, all rotation has stopped and the tractor is in park with the parking brake engaged. Make sure the mower head is resting on the ground or is securely blocked up and supported and all hydraulic pressure has been relieved.

Item	Condition at start of shift	Specific Comments if not O.K.
The operator's manual is in the canister on the mower.		
All warning decals are in place, clean and legible.		
All lights are clean and working.		
The mounting frame bolts are in place and tight.		
The arm pivot pins are tight and correctly secured.		
There are no cracks in the arms.		
Hydraulic cylinder pins are tight and correctly secured.		
Hydraulic cylinder hose connections are tight.		
Hydraulic pump hose connections are tight.		
Hydraulic valve hose connections are tight.		
Hydraulic valve controls function properly.		
There are no damaged hoses.		
The oil level is to the green mark on the tank sight glass.		
There is no evidence of hydraulic oil leaks.		
Flails are not missing, chipped, broken or excessively worn.		
The flail bolts are tight.		
The front and rear flaps are fitted and in good condition.		
The front hood is in place and in good condition.		
The wire trap is in good condition.		
The skid shoes are in good condition and tight.		
There are no cracks or holes in flail casing.		
Hydraulic motor mounting bolts are tight.		
All flail head nuts and bolts are tight.		
The rotor bearings are in good condition and greased.		
The roller bearings are in good condition and greased.		
The drive line shaft guard is in good condition.		
The drive line shaft guard is correctly secured.		
Controls are securely mounted in the cab.		
With engine running check arm operation.		
Have a spare pack of flails, bushes, bolts and nuts.		

Operators Signature:

DO NOT OPERATE AN UNSAFE TRACTOR OR MACHINE



TRACTOR PRE-OPERATION INSPECTION

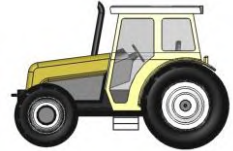

Power Arm ID Date: Shift:



WARNING: Before conducting the inspection, make sure the tractor engine is off, the key removed, all rotation has stopped and the tractor is in park with the parking brake engaged. Ensure any implement attached to the tractor is firmly on the ground.

Item	Condition at start of shift	Specific Comments if not O.K.
The flashing lights function properly.		
All lights are clean and working correctly.		
All cab windows are clean and wipers working correctly.		
The SMV sign, where required, is clean and visible.		
The tyres are in good condition with correct pressure.		
The wheel nuts are tight.		
The tractor brakes are in good condition.		
The steering linkage is in good condition.		
There are no visible oil leaks.		
The hydraulic controls function properly.		
The ROPS or ROPS cab is in good condition.		
The seatbelt is in place and in good condition.		
The 3-point hitch is in good condition.		
The drawbar/pick up hook is secure and in good condition.		
The PTO master shield is in place.		
The engine oil level is full.		
The brake fluid level is full.		
The power steering fluid level is full.		
The fuel level is adequate.		
The engine coolant fluid level is full.		
The radiator and oil cooler are free of debris.		
The air filter is in good condition.		

Operators Signature:

DO NOT OPERATE AN UNSAFE TRACTOR OR MACHINE

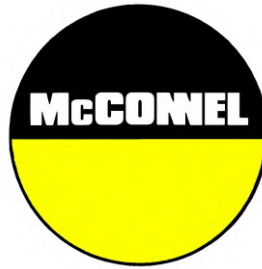

For Safety and Performance...

ALWAYS READ THE BOOK FIRST

McCONEL LIMITED

**Temeside Works
Ludlow
Shropshire
England**

**Telephone: +44 (0)1584 873131
www.mcconel.com**

- NOISE STATEMENT -

The equivalent daily personal noise exposure from this machine measured at the operators' ear is within the range 78 – 85 dB, these figures apply to a normal distribution of use where the noise fluctuates between zero and maximum. The figures assume that the machine is fitted to a tractor with a 'quiet' cab with the windows closed in a generally open environment. We recommend that the windows are kept closed. With the cab rear window open the equivalent daily personal noise exposure will increase to a figure within the range 82 – 88 dB. At an equivalent daily noise exposure level of 85 – 90 dB ear protection is recommended and must always be used if any window is left open.



Operating, servicing and maintaining this equipment can expose you to chemicals including gasoline, diesel fuel, lubricants, petroleum products, engine exhaust, carbon monoxide, and phthalates, which are known to the State of California to cause cancer and birth defects or other reproductive harm. To minimize exposure, avoid breathing exhaust, do not idle the engine except as necessary, service your vehicle in a well-ventilated area and wear gloves or wash your hands frequently when servicing your vehicle. Battery posts, terminals and related accessories contain lead and lead compounds, chemicals known to the state of California to cause cancer, birth defects or other reproductive harm. For more information go to www.P65Warnings.ca.gov. This website, operated by California's Office of Environmental Health Hazard Assessment, provides information about these chemicals and how individuals may be exposed to them.

CONTENTS

General Information	1
Specifications & Dimensions	2
Safety Information	6
Tractor / Vehicle Requirements	14
Vehicle / Tractor Preparation	15
Delivery & Pre-attachment	16
Parking Legs & Support Wheels	17
Machine Preparation & Attachment	19
Control Unit Installation	23
Flail Head Attachment	23
Operator Controls	25
Running Up Procedure	36
Emergency Stopping	36
Transportation	37
Manual Slew	38
Breakback Protection	39
Float Kits	40
Pre-work Preparation & Precautions	42
Operating Speed	43
Hedgecutting Procedure	44
Hazards & Dangers	45
Overhead Power Lines	46
Flails Identification	48
General Maintenance	50
Service Schedule	51
Side Shift Carriage	52
Flail Head	52
Hydraulic Hoses	53
Troubleshooting Chart	54

GENERAL INFORMATION

Always read this manual before fitting or operating the machine – whenever any doubt exists contact your dealer or the McConnel Service Department for advice and assistance.

Use only McConnel Genuine Service Parts on McConnel Equipment and Machines

Definitions; *The following definitions apply throughout this manual:*

WARNING

An operating procedure, technique etc., which –
can result in personal injury or loss of life if not observed carefully.

CAUTION

An operating procedure, technique etc., which –
can result in damage to either machine or equipment if not observed carefully.

NOTE

An operating procedure, technique etc., which –
is considered essential to emphasis.

LEFT AND RIGHT HAND

This term is applicable to the machine when attached to the tractor and is viewed from the rear – this also applies to tractor references.

Note: The illustrations in this manual are for instructional purposes only and may on occasion not show some components in their entirety. In some instances an illustration may appear slightly different to that of your particular model but the general procedure will be the same. E&OE.

MACHINE & DEALER INFORMATION

Record the Serial Number of your machine on this page and always quote this number when ordering parts. Whenever information concerning the machine is requested remember also to state the make and model of tractor to which the machine is fitted.

Machine Serial Number:	Installation Date:
Machine Model details:	
Dealer Name:	
Dealer Address:	
Dealer Telephone No:	
Dealer Email Address:	

Machine Identification

All machines are fitted with an identification plate; when ordering parts from your local dealer please quote machine part number and serial number as stated on this plate so that machine and model can be easily identified.



Machine Identification Plate

SPECIFICATIONS & DIMENSIONS

Technical Specifications

Machine	PA3430 VERSI	PA4030 VERSI
Description	<i>Dual Direction Front Mount</i>	<i>Dual Direction Front Mount</i>
Head Rotation	<i>Manual (Pin Locking)</i>	<i>Manual (Pin Locking)</i>
Vehicle Requirements		
Minimum Power	<i>35HP</i>	<i>35HP</i>
Minimum Vehicle Weight	<i>1750kg</i>	<i>2000kg</i>
Mounting Types	<i>3-Pt Linkage DIN Plate Specialist Frame</i>	<i>3-Pt Linkage DIN Plate Specialist Frame</i>
Machine Specifications		
Maximum Reach	<i>3.4m (11' 2")</i>	<i>4.0m (13' 1")</i>
Manual Slew	<i>180°</i>	<i>180°</i>
Breakback	<i>17.5°</i>	<i>17.5°</i>
Power	<i>30HP</i>	<i>30HP</i>
Machine Weight	<i>469kg</i>	<i>489kg</i>

Dimensions – PA3430 VERSI

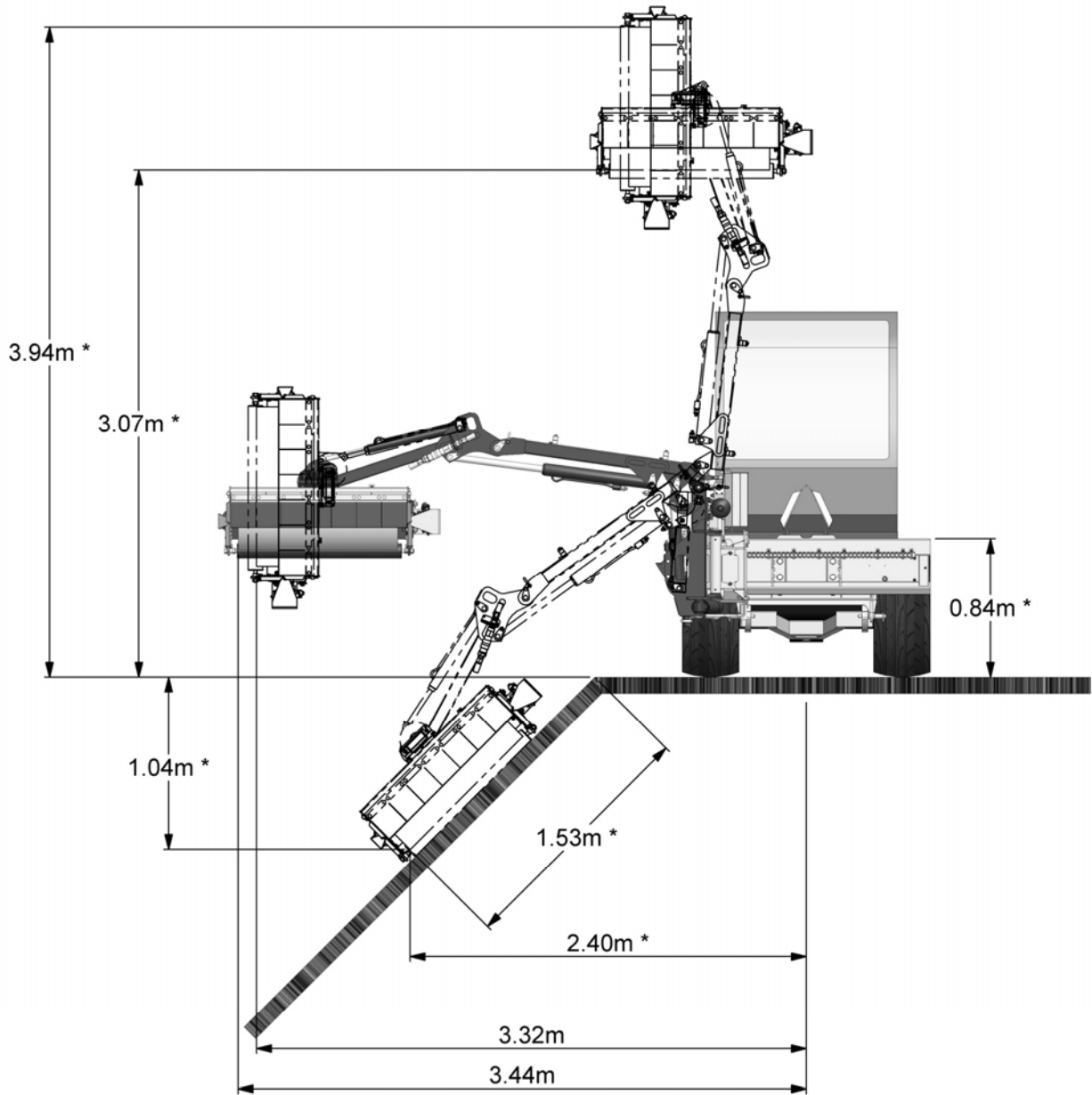

NOTE DIMENSIONS MARKED "*" WILL VARY DEPENDING ON THE HEIGHT AT WHICH THE MACHINE IS MOUNTED

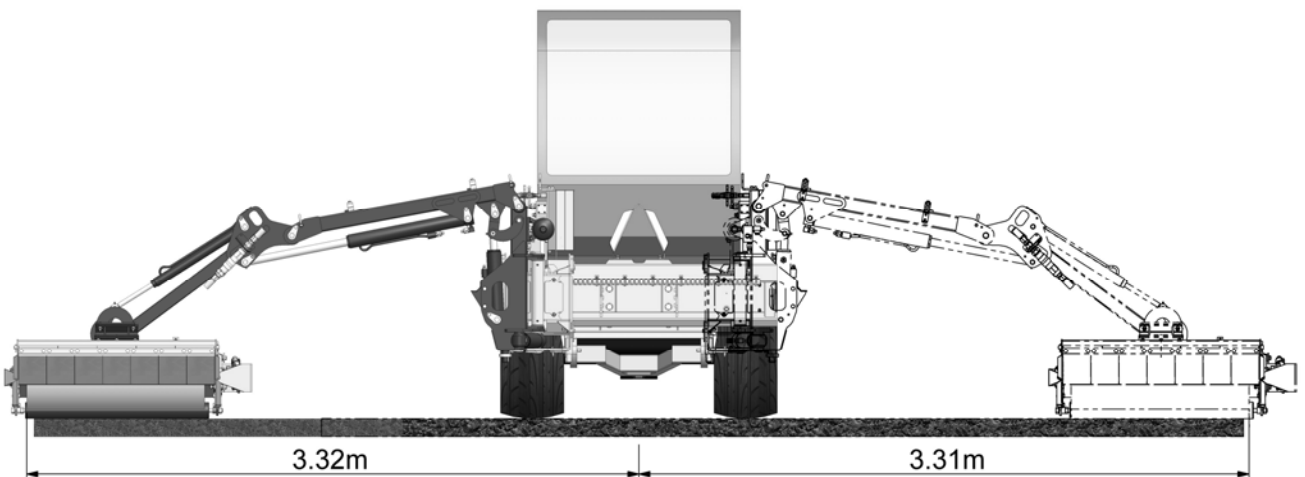

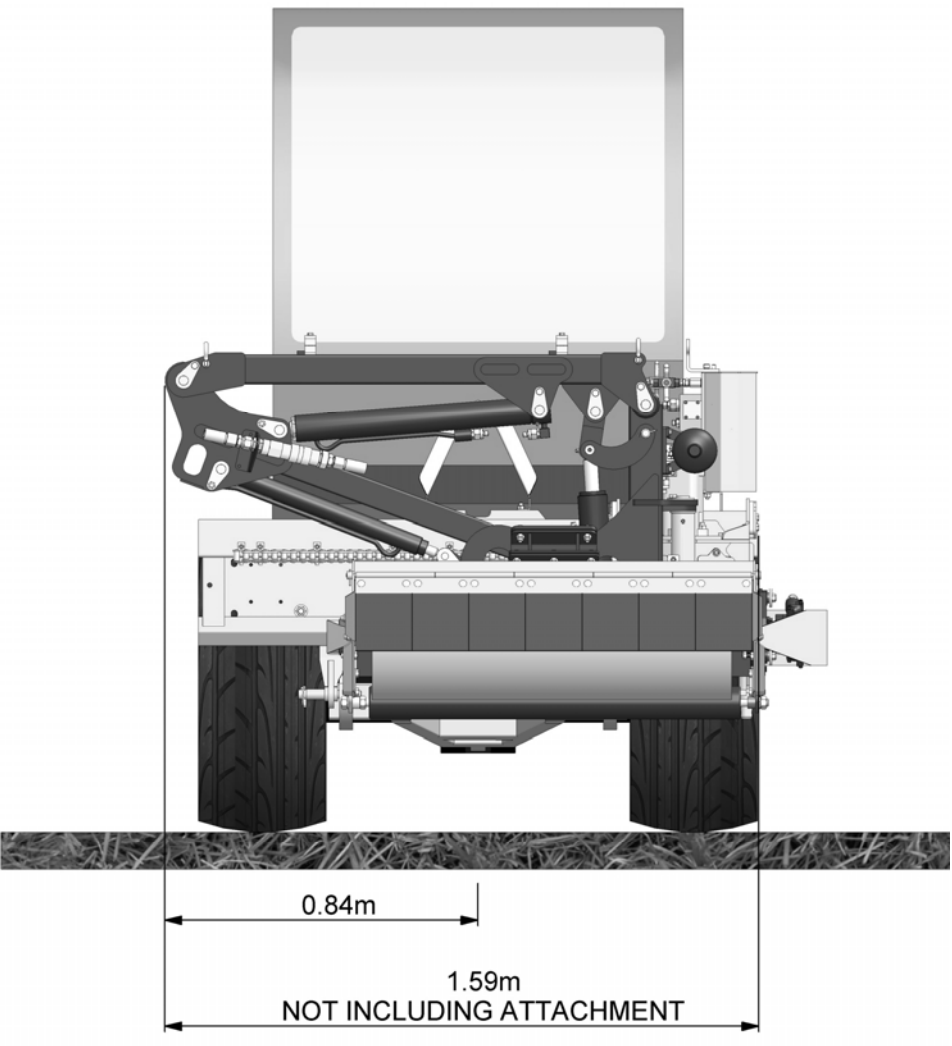
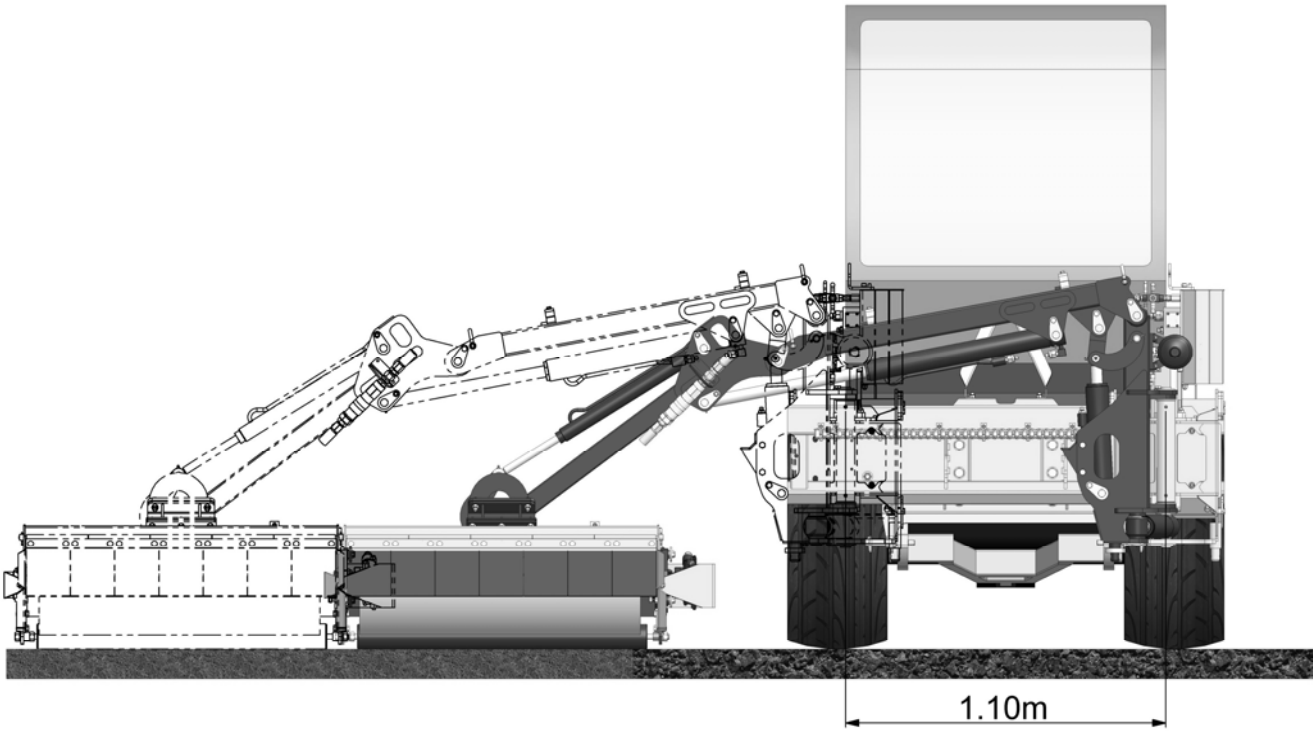

Dimensions – PA4030 VERSI

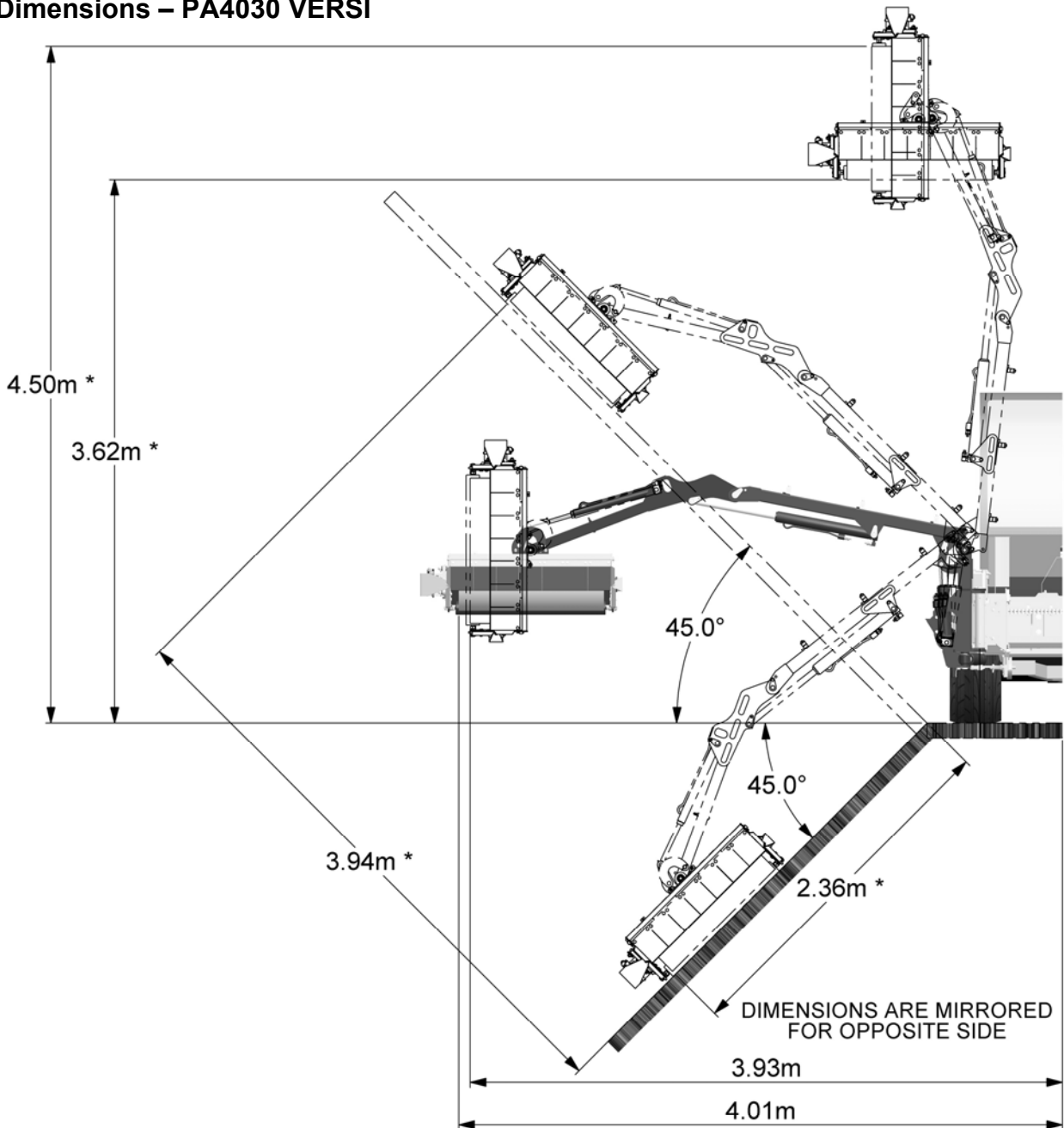

NOTE DIMENSIONS MARKED WITH A * WILL VARY DEPENDING ON THE HEIGHT AT WHICH THE MACHINE IS MOUNTED TO THE CARRIER VEHICLE

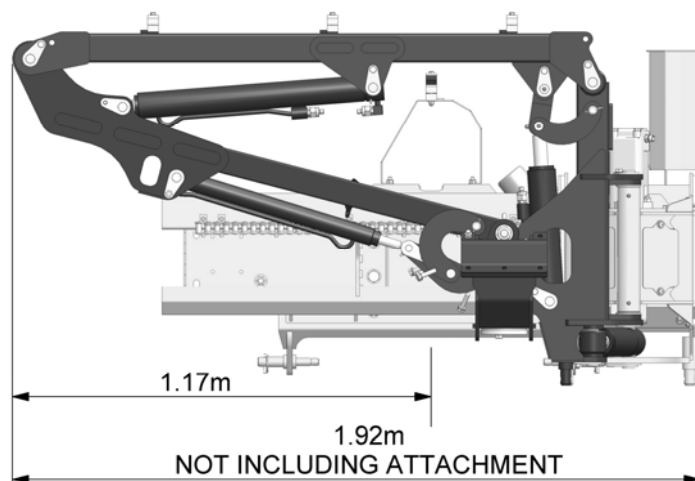



This machine has the potential to be extremely dangerous - in the wrong hands it can kill or maim; It is therefore imperative that both owner and operator of the machine reads and understands the following section to ensure they are fully aware of the dangers that do, or may exist, and their responsibilities surrounding the use and operation of the machine.

The operator of this machine is responsible not only for their own safety but equally for the safety of others who may come into the close proximity of the machine, as the owner you are responsible for both.

When the machine is not in use the cutting head should be lowered to rest on the ground. In the event of any fault being detected with the machine's operation it must be stopped immediately and not used again until the fault has been corrected by a qualified technician.

POTENTIAL SIGNIFICANT DANGERS ASSOCIATED WITH THE USE OF THIS MACHINE:

- ▲ *Being hit by debris thrown by rotating components.*
- ▲ *Being hit by machine parts ejected through damage during use.*
- ▲ *Being caught on a rotating power take-off (PTO) shaft.*
- ▲ *Being caught in other moving parts i.e.: belts, pulleys and cutting heads.*
- ▲ *Electrocution from Overhead Power Lines (by contact with or 'flashover' from).*
- ▲ *Being hit by cutting heads or machine arms as they move.*
- ▲ *Becoming trapped between tractor and machine when hitching or unhitching.*
- ▲ *Tractor overbalancing when machine arm is extended.*
- ▲ *Injection of high-pressure oil from hydraulic hoses or couplings.*
- ▲ *Machine overbalancing when freestanding (out of use).*
- ▲ *Road traffic accidents due to collision or debris on the road.*
- ▲ *Burn risk from hot components.*

BEFORE USING THIS MACHINE YOU MUST:

- ▲ *Ensure you read all sections of the operator handbook.*
- ▲ *Ensure the operator is, or has been, properly trained to use the machine.*
- ▲ *Ensure the operator has been issued with and reads the operator handbook.*
- ▲ *Ensure the operator understands and follows the instructions in operator handbook.*
- ▲ *Ensure the tractor front, rear and sides are fitted with metal mesh or polycarbonate guards of suitable size and strength to protect the operator against thrown debris or parts.*
- ▲ *Ensure tractor guards are fitted correctly, are undamaged and kept properly maintained.*
- ▲ *Ensure that all machine guards are in position, are undamaged, and are kept maintained in accordance with the manufacturer's recommendations.*
- ▲ *Ensure flails and their fixings are of a type recommended by the manufacturer, are securely attached and that none are missing or damaged.*
- ▲ *Ensure hydraulic pipes are carefully and correctly routed to avoid damage by chaffing, stretching or pinching and that they are held in place with the correct fittings.*
- ▲ *Always follow the manufacturer's instructions for attachment and removal of the machine from the tractor.*
- ▲ *Check that the machine fittings and couplings are in good condition.*
- ▲ *Ensure the tractor meets the minimum weight recommendations of the machine's manufacturer and that ballast is used as necessary.*
- ▲ *Always inspect the work area thoroughly before starting to note obstacles and remove wire, bottles, cans and other debris.*
- ▲ *Use clear suitably sized warning signs to alert others to the nature of the machine working within that area. Signs should be placed at both ends of the work site. (It is recommended that signs used are of a size and type specified by the Department of Transport and positioned in accordance with their, and the Local Highways Authority, guidelines).*
- ▲ *Ensure the operator is protected from noise. Ear defenders should be worn and tractor cab doors and windows must be kept closed. Machine controls should be routed through proprietary openings in the cab to enable all windows to be shut fully.*
- ▲ *Always work at a safe speed taking account of the conditions i.e.: terrain, highway proximity and obstacles around and above the machine. Extra special attention should be applied to Overhead Power Lines. Some of our machines are capable of reach in excess of 8 metres (26 feet) this means they have the potential to well exceed, by possibly 3 metres (9' 9"), the lowest legal minimum height of 5.2 metres from the ground for 11,000 and 33,000 volt power lines. It cannot be stressed enough the dangers that surround this capability, it is therefore vital that the operator is fully aware of the maximum height and reach of the machine, and that they are fully conversant with all aspects regarding the safe minimum distances that apply when working with machines in close proximity to Power Lines. (Further information on this subject can be obtained from the Health & Safety Executive or your Local Power Company).*

- ▲ *Always disengage the machine, kill the tractor engine, remove and pocket the key before dismounting for any reason.*
- ▲ *Always clear up all debris left at the work area, it may cause hazard to others.*
- ▲ *Always ensure when you remove your machine from the tractor that it is left in a safe and stable position using the stands and props provided and secured if necessary.*

WHEN NOT TO USE THIS MACHINE:

- ▲ *Never attempt to use this machine if you have not been trained to do so.*
- ▲ *Never use a machine until you have read and understood the operator handbook, are familiar with it, and practiced the controls.*
- ▲ *Never use a machine that is poorly maintained.*
- ▲ *Never use a machine if guards are missing or damaged.*
- ▲ *Never use a machine on which the hydraulic system shows signs of wear or damage.*
- ▲ *Never fit, or use, a machine on a tractor that does not meet the manufacturer's minimum specification level.*
- ▲ *Never use a machine fitted to a tractor that does not have suitable front, rear and side(s) cab guarding made of metal mesh or polycarbonate.*
- ▲ *Never use the machine if the tractor cab guarding is damaged, deteriorating or badly fitted.*
- ▲ *Never turn a machine cutting head to an angle that causes debris to be ejected towards the cab.*
- ▲ *Never start or continue to work a machine if people are nearby or approaching - Stop and wait until they are at a safe distance before continuing. WARNING: Some cutting heads may continue to 'freewheel' for up to 40 seconds after being stopped.*
- ▲ *Never attempt to use a machine on materials in excess of its capability.*
- ▲ *Never use a machine to perform a task it has not been designed to do.*
- ▲ *Never operate the tractor or machine controls from any position other than from the driving seat, especially whilst hitching or unhitching the machine.*
- ▲ *Never carry out maintenance of a machine or a tractor whilst the engine is running – the engine should be switched off, the key removed and pocketed.*
- ▲ *Never leave a machine unattended in a raised position – it should be lowered to the ground in a safe position on a level firm site.*
- ▲ *Never leave a tractor with the key in or the engine running.*
- ▲ *Never carry out maintenance on any part or component of a machine that is raised unless that part or component has been properly substantially braced or supported.*
- ▲ *Never attempt to detect a hydraulic leak with your hand – use a piece of cardboard.*
- ▲ *Never allow children near to, or play on, a tractor or machine under any circumstances.*

ADDITIONAL SAFETY ADVICE

Training

Operators need to be competent and fully capable of operating this machine in a safe and efficient way prior to attempting to use it in any public place. We advise therefore that the prospective operator make use of relevant training courses available such as those run by the Agricultural Training Board, Agricultural Colleges, Dealers and McConnel.

Working in Public Places

When working in public places such as roadsides, consideration should be paid to others in the vicinity. Stop the machine immediately when pedestrians, cyclists and horse riders etc. pass. Restart only when they are at a distance that causes no risk to their safety.

Warning Signs

It is advisable that any working area be covered by suitable warning signs and statutory in public places. Signs should be highly visible and well placed in order to give clear advanced warning of the hazard. Contact the Department of Transport or your Local Highways Authority to obtain detailed information on this subject. The latter should be contacted prior to working on the public highway advising them of the time and location of the intended work asking what is required by way of signs and procedure. – *'Non-authorised placement of road signs may create offences under the Highways Act'*.

Suggested Warning Signs Required

'Road works ahead' warning sign with a supplementary *'Hedge cutting'* plate. *'For 1 mile'* or appropriate shorter distance may be added to the plate.

'Road narrows' warning signs with supplementary *'Single file traffic'* plate.

White on blue *'Keep right'* (*) arrow sign on rear of machine.

** Note – this applies to UK Market machines where traffic passes to the right of a machine working in the same direction as the traffic flow. The direction, use and colour of the arrow sign will depend on the country of use and the Local Highway Authorities regulations in the locality.*

Use of Warning Signs

- ▲ *On two-way roads one set of signs is needed facing traffic in each direction.*
- ▲ *Work should be within 1 mile of the signs.*
- ▲ *Work only when visibility is good and at times of low risk e.g.: NOT during 'rush-hour'.*
- ▲ *Vehicles should have an amber-flashing beacon.*
- ▲ *Ideally, vehicles should be conspicuously coloured.*
- ▲ *Debris should be removed from the road and path as soon as practicable, and at regular intervals, wearing high visibility clothing and before removing the hazard warning signs.*
- ▲ *Collect all road signs promptly when the job is completed.*

Although the information stated here covers a wide range of safety subjects it is impossible to predict every eventuality that can occur under differing circumstances whilst operating this machine. No advice given here can replace 'good common sense' and 'total awareness' at all times, but will go a long way towards the safe use of your McConnel machine.

Safe use of rotary flail hedge cutters

HSE information sheet

Agriculture Information Sheet No 21 (Revision 1)

Introduction

This information sheet outlines typical hazards when using most types of tractor-mounted rotary flail hedge cutter. It gives guidance on reducing risks to the operator and others during work with hedge cutters and will help employers, employees and the self-employed comply with their duties under health and safety law.

All users of rotary flail hedge cutters need to be aware of the particular features of their make/model of hedge cutter when considering the hazards, risks and precautions.

Hazards

The greatest risk of injury comes from contact with the machine's moving parts and in particular:

- entanglement on inadequately guarded power take-off shafts;
- contact with the cutter head parts, drive belts or pulleys;
- being struck by the cutting head or machine arm as it moves.

Other risks associated with tractor-mounted hedge cutters can include:

- being hit by material or other debris ejected by the cutters;
- being hit by component parts ejected from the machine;
- coming into contact with overhead electricity power lines (OHPLs);
- the tractor overbalancing when the machine arm is extended;
- injection of high-pressure oil from damaged hydraulic hoses or couplings;
- being struck by the machine overbalancing when un-hitched from the tractor;
- road traffic accidents due to collisions with other vehicles either directly or from debris on the road.

Control measures

It is extremely dangerous to carry out any work on a machine while it is under power. The most important safety measure is to follow the 'safe stop' procedure before dismounting, or carrying out any maintenance or adjustments, including dealing with a blockage or other problem:

- Handbrake on.
- Controls neutral.
- Stop engine.
- Remove key.

Guards and machine safety

Check that all guards and other protective devices are in place before starting work. Don't use the machine if the guards are missing or damaged. Make sure:

- the power take-off (PTO) shaft is fully enclosed in a guard along its entire length from the tractor power take-off to the power input connection on the hedge cutter;
- the tractor rear and side(s) are fitted with protective glazing, metal mesh or polycarbonate guards of a size/strength specified by the hedge cutter manufacturer to protect the operator against thrown debris or other projectiles;
- tractor mesh/polycarbonate guards are suitable for the job, undamaged and maintained in accordance with the manufacturer's instructions;
- all hedge cutter guards and safety devices are in position, correctly fitted and maintained in accordance with the manufacturer's recommendations;
- flails and their fixing heads are the right size for the task. Flails, and their fixings, should be of the type recommended by the manufacturer, securely attached, and should not be missing or damaged;
- hydraulic pipes are carefully routed to avoid damage;
- machine fittings and couplings are in good condition.

General guidance on safe working practice

- Operators should receive adequate instructions and training to enable them to use the machine safely. Take advantage of relevant training/courses provided by manufacturers/dealers. They will help ensure your safety and that of your staff, and help you get the best performance from your hedge cutter.
- Make sure the operator reads, understands and follows the instruction manual.
- Follow the manufacturer's instructions when hitching or unhitching the machine from the tractor. Do not stand in any position where you may be at risk of being crushed, eg in the area between the back of the tractor and the cutter.
- Make sure the machine is left in a stable position when it is removed from the tractor, using any stands or props provided, and securing it further if necessary.
- Do not carry out maintenance on the hedge cutter with the cutting arm/dipper arm raised, unless the arm is properly supported.
- Check the tractor is at least the minimum weight recommended by the hedge cutter manufacturer. Use ballast as necessary.
- Inspect the hedge before starting to cut and remove wire, bottles, cans and other debris. Check for any telegraph/electricity pole stays. Damaged stays should be reported to the relevant Telecoms Company/Distribution Network Operator.
- Use appropriate warning signs to alert others to the hedge-cutting operation where necessary.
- Work at a safe speed, taking account of the conditions (eg terrain, proximity to the highway, or obstacles).
- Use safe practices when work needs to be done near OHPLs. Flailhead units on some dipper arms can reach over 5.2 metres, the minimum height of OHPLs above ground level (see Further reading).
- Clear up debris after cutting if it could be a hazard to others.

Roadside hedges

Take extra care if you are hedge/verge cutting along a road. Consider what measures you will need to control the risks to other road users (eg vehicles, cyclists, pedestrians, or horse riders). For roadside work (on the public highway) there are other legal requirements. For example, there may be obligations to:

- display specific warning signs in defined locations where work is carried out;
- fit flashing beacons to tractors/machines;
- clear debris from paths and roads;
- restrict your working hours.

Consult your local authority highways department and the Department for Transport for advice (see Further reading).

Further reading

Traffic signs manual 2009. Chapter 8. Traffic safety measures and signs for road works and temporary situations. Part 2: Operations DfT ISBN 978 0 11 553052 4 <http://assets.dft.gov.uk/publications/traffic-signs-manual/traffic-signs-manual-chapter-08-part-02.pdf>

Working safely near overhead electricity power lines AIS8(rev3) HSE Books 2012 www.hse.gov.uk/pubns/ais8.htm

Further information

For information about health and safety, or to report inconsistencies or inaccuracies in this guidance, visit www.hse.gov.uk/. You can view HSE guidance online and order priced publications from the website. HSE priced publications are also available from bookshops.

This guidance is issued by the Health and Safety Executive. Following the guidance is not compulsory, unless specifically stated, and you are free to take other action. But if you do follow the guidance you will normally be doing enough to comply with the law. Health and safety inspectors seek to secure compliance with the law and may refer to this guidance.

This document is available at www.hse.gov.uk/pubns/ais21.htm.

© *Crown copyright* If you wish to reuse this information visit www.hse.gov.uk/copyright.htm for details. First published 10/12.

SAFETY & INFORMATION DECALS (Power Arms)

Power Arm machines are equipped with safety and information decals designed to warn of dangers, operational information and machine protection. Operators must understand the decals and heed all warnings. Keep decals in a good condition and replace immediately if they are damaged or missing.



1.

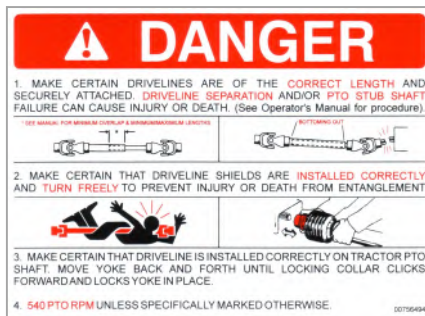

2.



3.



4.



5.



6.



7.



8.



9.



10.



11.



12.



13.



14.



15.

- General Safety Warnings.
- Driveline Hazard Warning.
- Tighten Check Chains Warning.
- 'In vehicle' Safety Rules Decal.
- Serial Number Plate.
- Read the Book First.
- Lift Point with SWL (Kg).
- Specific Pinch Point Warning.
- Maximum vehicle PTO Speed & Direction Warning.
- Oil Filter Initial and subsequent change information.
- Lift Point for shipping only; stow when machine installed on vehicle. (Models with stowable lift eyes only).
- Auto-breakaway Return Warning; in 'Auto-Reset' arm will automatically return to the work position, when possible.
- Vehicle Clearance Warning; leave 300mm+ between arm and vehicle.
- Lift Stop Clearance Warning; leave 300mm+ between arm and vehicle, leave 5mm between arm and stop.
- Lift Tap 'Lock' Warning; leave 300mm+ between arm and vehicle, lock lift taps for transport.

SAFETY & INFORMATION DECALS (Flail Heads)

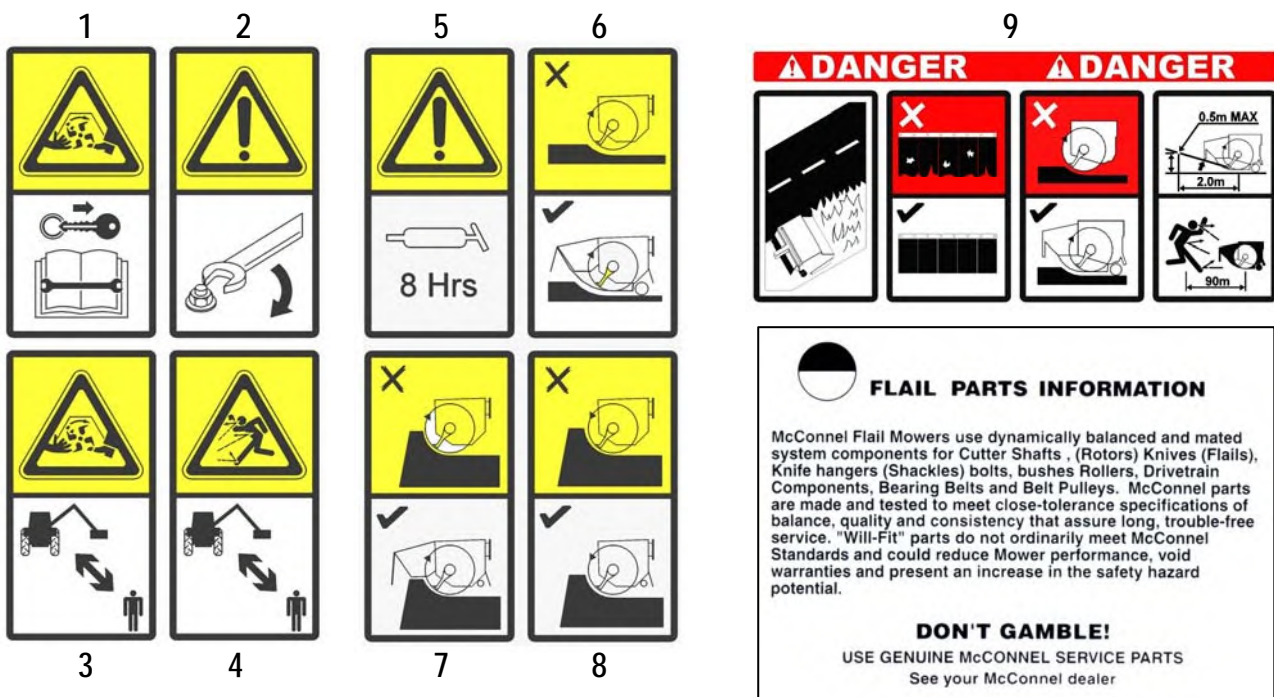

1. **Caution!** Rotating blades; keep clear of machine, stop machine (wait for rotor to stop), remove vehicle key and read the book first before performing any service or maintenance.
2. **Caution!** Keep all nuts and bolts tight.
3. **Caution!** Rotating components; keep clear of the working machine.
4. **Caution!** Thrown objects risk; keep all persons at a safe distance from the working machine.
5. **Caution!** Lubricate greasing points every 8 working hours.
6. **Caution!** Grass/Verge Mowing; front hood, front flap, rear roller and rear flap must be fitted and correctly adjusted when using the machine for grass and verge mowing. Flaps must be in good condition.
7. **Caution!** Hedging (Uphill cutting); front hood, front flap and rear flap must always be fitted and correctly adjusted. Rear roller should be placed into the raised position. Flaps must be in good condition.
8. **Caution!** Hedging (Downhill cutting); front hood may be removed; rear flap must be fitted and rear roller placed into the raised position. Flap must be in good condition.
9. **Danger!** Road side mowing. Flaps must be in good condition. Do not work if front hood, front flaps, rear roller and rear flaps not fitted. Front hood, front flaps, rear roller and rear flaps must be fitted. Adjust front hood to the correct height position for verge mowing. A extended straight line from the bottom of the rotor and bottom of the front flap should not be higher than 0.5m at a horizontal distance of 2.0m from the rotor. Keep all persons at 90m from the working machine, stop machine if persons are closer. *Refer to front hood height setting section for details.*
10. **Important!** Parts information; for safety and performance only use 'Genuine McConnel Service Parts'.

TRACTOR / VEHICLE REQUIREMENTS

Tractor / Vehicle Weight *(Including ballast weight if necessary)*

PA3430 VERSI Model - 1750kg minimum

PA4030 VERSI Model - 2000kg minimum

HP Requirement

Minimum 35HP

PTO Shaft - *where applicable*

Tractor must be equipped with a live drive PTO to enable continuous flailhead operation when forward motion of the tractor is stopped.

Check Chains / Stabilizers - *3-point linkage machines only*

Check chains or stabilizers must be fitted and tightened.

Front Mounted Machines

Before fitting a front mounted machine to your tractor seek the advice of the tractor manufacturer or your local dealer regarding suitability and relevant information relating to additional linkage, ballast or weights that may be required.

CAUTION!



Never attach a machine to a tractor that is unsuitable or poorly maintained – where doubt exists always seek the advice of the tractor manufacturer or your local dealer before attempting to fit the machine.

VEHICLE / TRACTOR PREPARATION

We recommend vehicles are fitted with cabs using 'safety glass' windows and protective guarding when used with our machines.

Fit Operator Guard (Part No. 7313324) using the hooks provided. Shape the mesh to cover all vulnerable areas. The driver must be looking through mesh and/or polycarbonate glazing when viewing the flail head in any working position - unless the vehicle/ cab

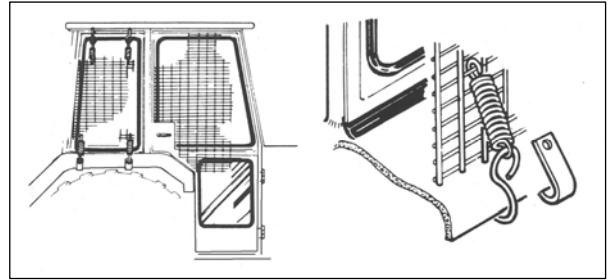

manufacturer can demonstrate that the penetration resistance is equivalent to, or higher than, that provided by mesh/polycarbonate glazing. If the tractor has a roll bar only, a frame must be made to carry both mesh and polycarbonate glazing. The operator should also use personal protective equipment to reduce the risk of serious injury such as; eye protection (mesh visor to EN1731 or safety glasses to EN166), hearing protection to EN352, safety helmet to EN297, gloves, filter mask and high visibility clothing.

Vehicle Ballast: It is imperative when attaching 'third-party' equipment to a vehicle that the maximum possible stability of the machine and vehicle combination is achieved – this can be accomplished by the utilization of 'ballast' in order to counter-balance the additional equipment added. **Front weights** may be required for rear mounted machines to place 15% of total outfit weight on the front axle for stable transport on the road and to reduce 'crabbing' due to the drag of the cutting unit when working on the ground.

Rear weights may be required to maintain a reasonable amount of rear axle load on the opposite wheel from the arms when in work; for normal off-ground work i.e. hedge cutting this should be 20% of rear axle weight or more for adequate control, and for ground work i.e. verge mowing with experienced operators, this can be reduced to 10%.

All factors must be addressed in order to match the type and nature of the equipment added to the circumstances under which it will be used – in the instance of Power Arm Hedgecutters it must be remembered that the machines centre of gravity during work will be constantly moving and will differ from that during transport mode, therefore balance becomes critical.

Factors that effect stability:

- *Centre of gravity of the tractor/machine combination.*
- *Geometric conditions, e.g. position of the cutting head and ballast.*
- *Weight, track width and wheelbase of the tractor.*
- *Acceleration, braking, turning and the relative position of the cutting head during these operations.*
- *Ground conditions, e.g. slope, grip, load capability of the soil/surface.*
- *Rigidity of implement mounting.*

Suggestions to increase stability:

- *Increasing rear wheel track; a vehicle with a wider wheel track is more stable.*
- *Ballasting the wheel; it is preferable to use external weights but liquid can be added to around 75% of the tyre volume – water with anti-freeze or the heavier Calcium Chloride alternative can be used.*
- *Addition of weights – care should be taken in selecting the location of the weights to ensure they are added to a position that offers the greatest advantage.*
- *Front axle locking (check with tractor manufacturer).*

NOTE: The advice above is offered as a guide for stability only and is not a guide to vehicle strength. It is recommended that you consult your vehicle manufacturer or local dealer to obtain specific advice on this subject, additionally advice should be sought from a tyre specialist with regard to tyre pressures and ratings suitable for the type and nature of the machine you intend to fit.

DELIVERY & PRE-ATTACHMENT (Dealer Reference)

Delivery

Where a machine is delivered in a partially dismantled condition secured with transport straps and banding a firm level site should be selected on which to place the machine before removing the straps, banding and other loose items.

Handling the Machine

Handling of the machine should always be performed using suitable overhead lifting equipment with a minimum safe lifting capacity over and above the maximum weight of the machine. Always ensure the machine is balanced during the lifting procedure and that all bystanders are kept well clear of the raised machine. Always ensure parking legs are correctly attached and secured before allowing the weight of the machine to rest on them.

Lifting Points

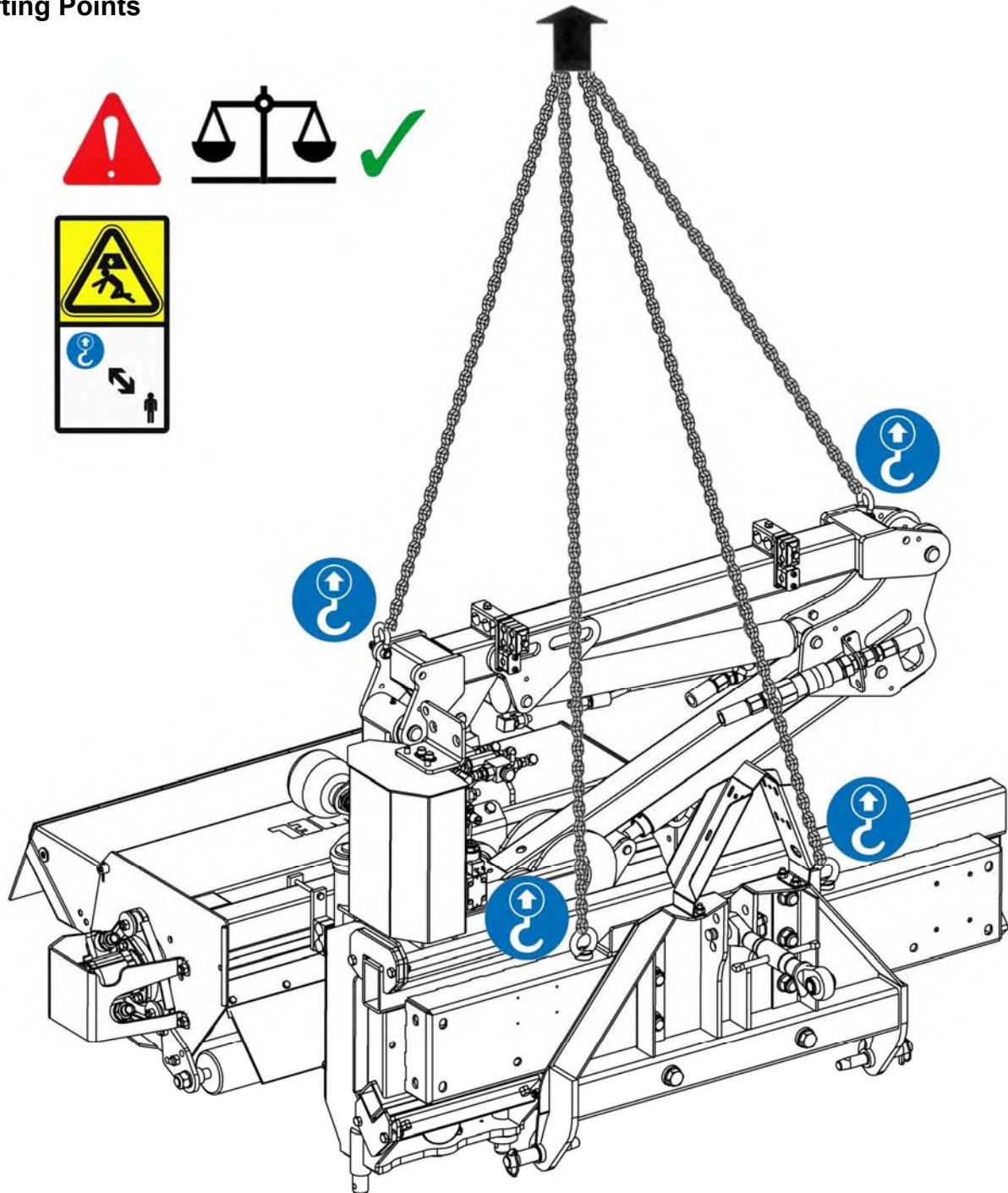

WARNING! Ensure raised machine is balanced and all persons are kept at a safe distance from the raised machine.

Parking Legs - Attachment

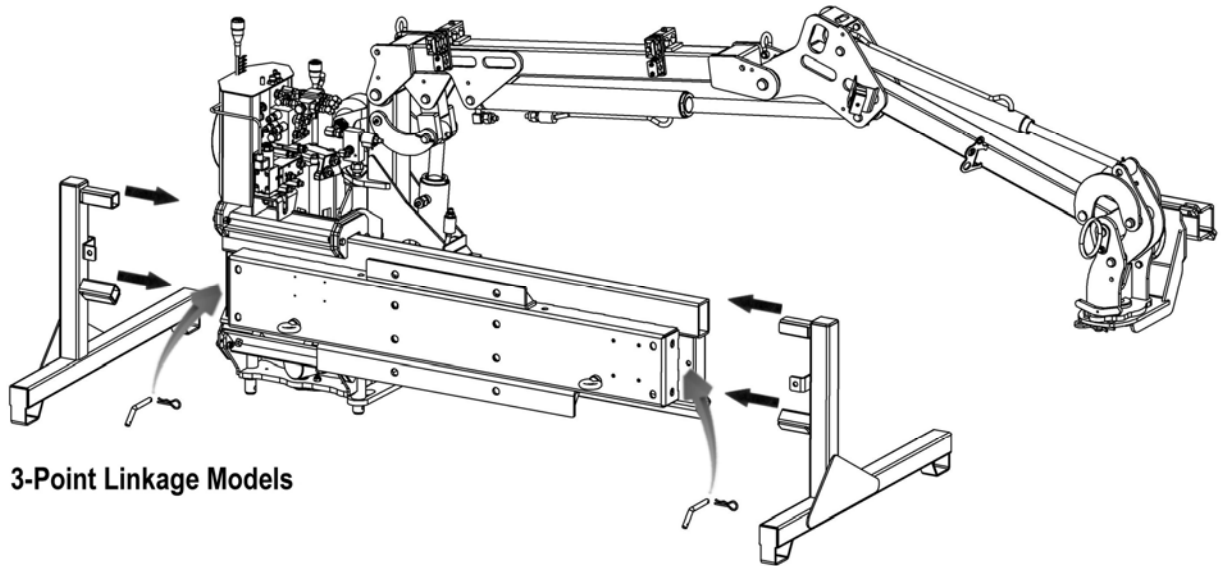

3-Point Linkage Models

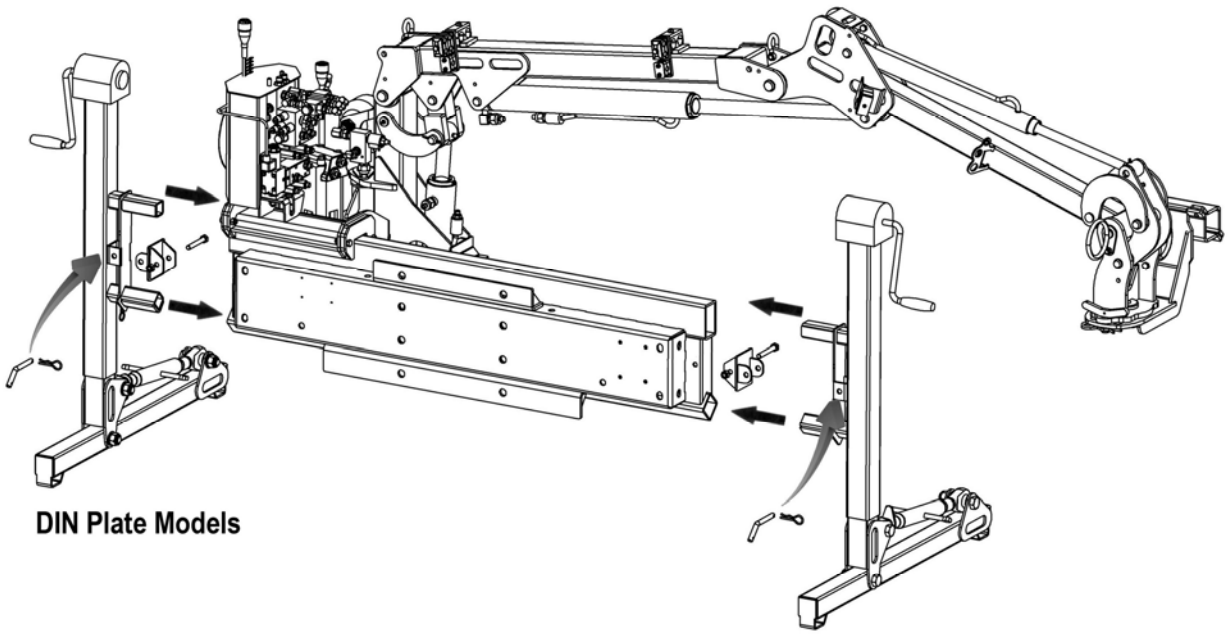

DIN Plate Models

Support Wheels Attachment – optional extra for machines used on narrow vehicles

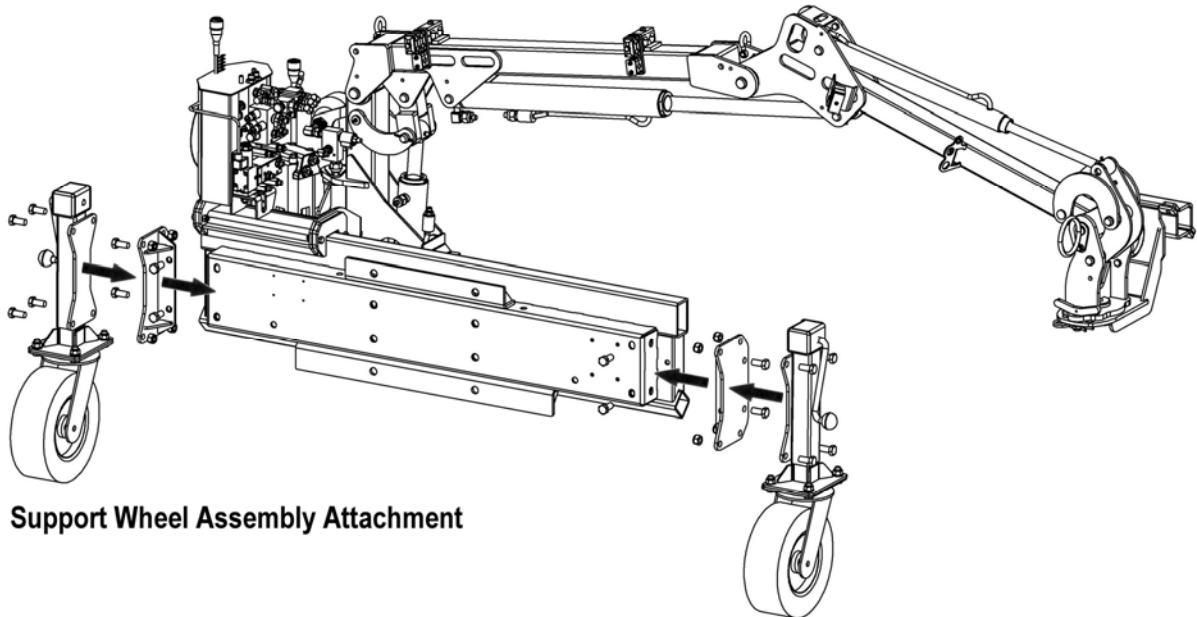

Support Wheel Assembly Attachment

Parking Legs Fitted

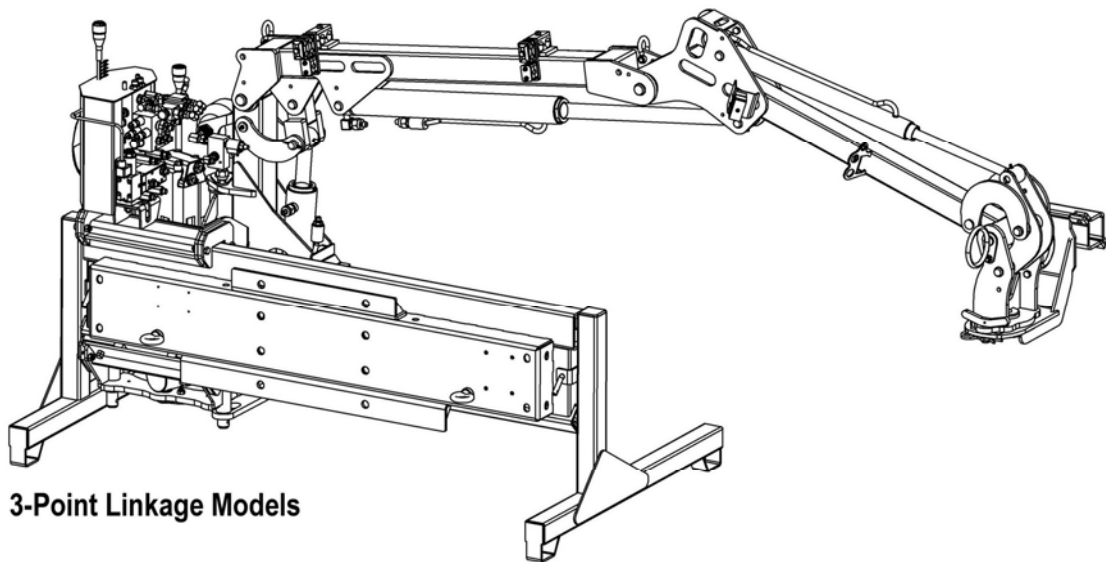

3-Point Linkage Models

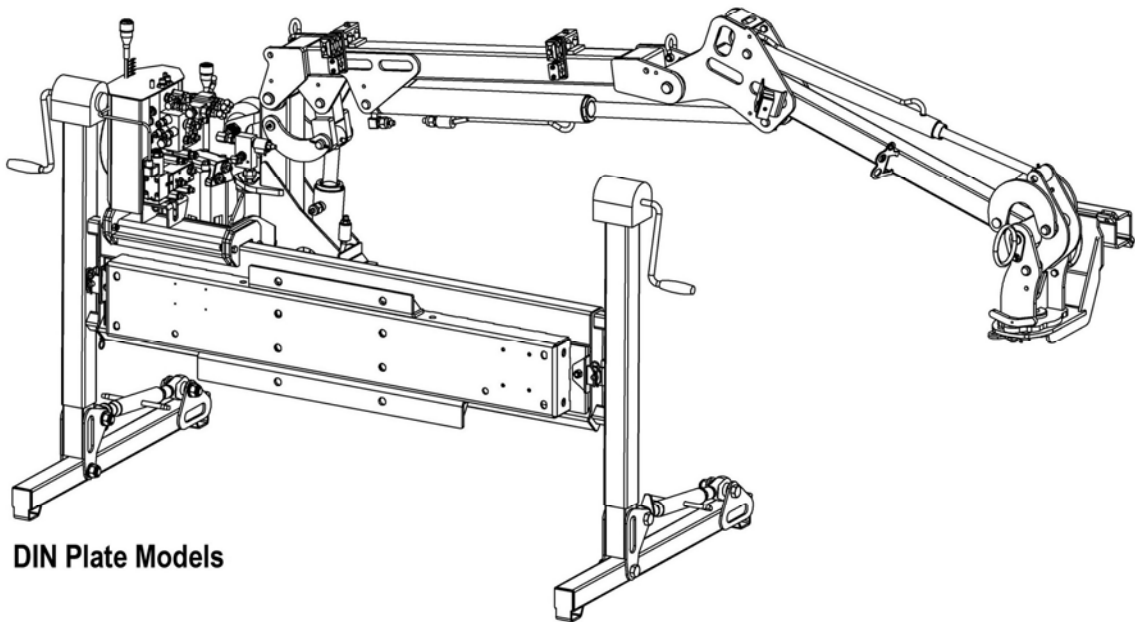

DIN Plate Models

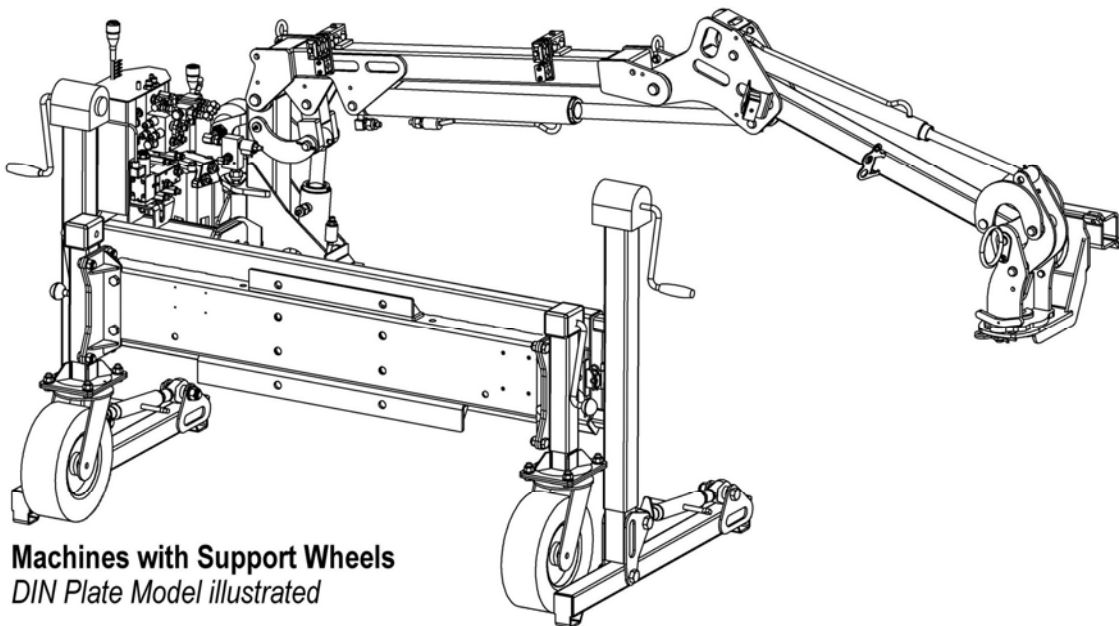

Machines with Support Wheels
DIN Plate Model illustrated

MACHINE PREPARATION & ATTACHMENT

The attachment procedure must always be performed on a firm level site, never attempt to attach the machine on sloping or soft ground. Keep all bystanders at a safe distance.

Attach Machine Parking Legs

Parking legs must be fitted to place the machine at the correct height for attachment to the carrying vehicle; 3-point linkage mounted machines have fixed height legs and DIN plate mounted machines have height adjustable legs.

Suitable overhead lifting gear will be required to raise the machine in order to fit the legs. Ensure the machine is raised using the correct lifting points as indicated below and that the machine remains balanced during the lifting procedure.

Keep all persons at a safe distance from the machine whilst it is in a raised position. With the parking legs correctly attached, lower the machine to the ground on a firm level site; ensure the chosen site provides sufficient space for subsequent vehicle attachment.

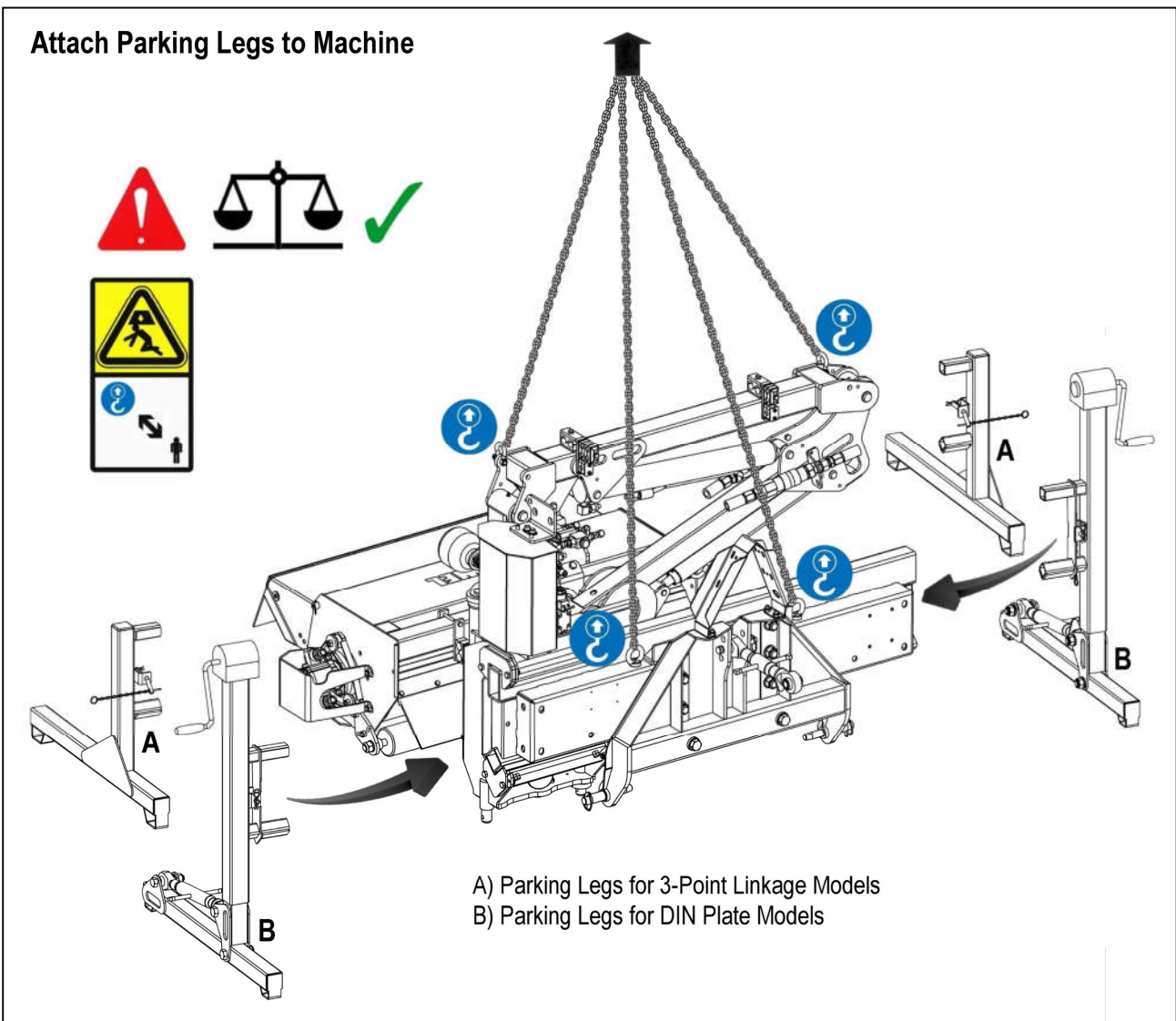

Parking Legs (DIN Plate Mount Machines)

DIN plate mounted machines are fitted with jack legs that can be adjusted to the required height for mounting the machine; each leg is also fitted with link type adjusters to provide vertical levelling of the machine.

Adjustment of the jack legs should be made incrementally on each side until the correct height is achieved.

Levelling the Machine

It is important for attachment that the machine is levelled in both the side to side and front to back directions, the procedure for this is as follows:

Vertical Adjustment

Vertical adjustments are made using the link type adjusters on the base of the each stand leg; make adjustments incrementally on each side to ensure stability is retained.

For ease of attachment to a vehicle the vertical position should be adjusted to place the DIN attachment plate of the machine parallel to the DIN plate on the vehicle.

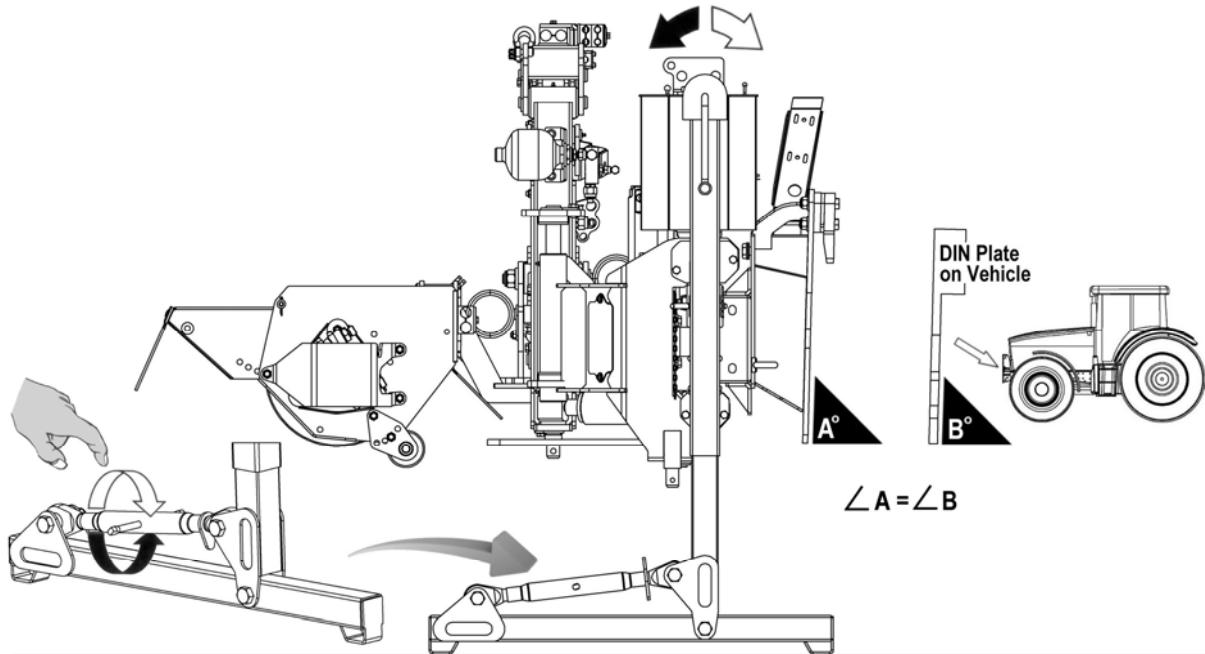

Horizontal Adjustment & Height

Raise the machine to the required attachment height by use of the stand leg ratchet jacks located on each side of the machine; for ease of operation, and reasons of stability, this should be done by alternately operating each jack to raise the machine in steps of approximately 50mm at a time until the desired height is achieved – see illustration below. Ensure the machine is level (side to side) at the end of the procedure.

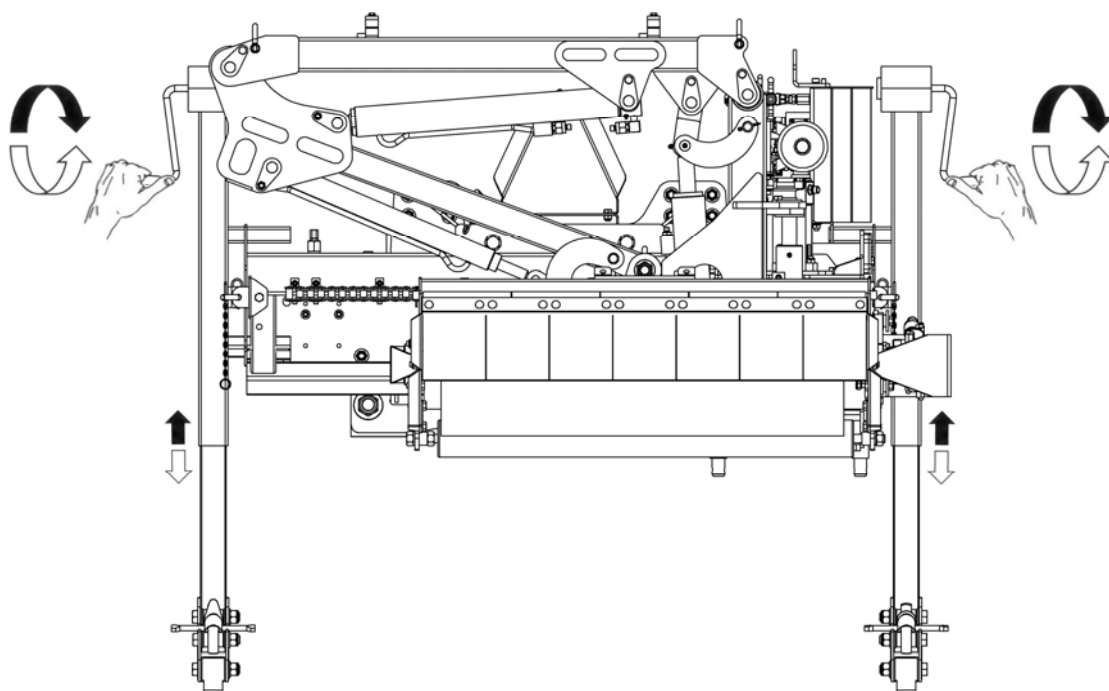

ATTACHING THE MACHINE – DIN Plate Front Mount Models

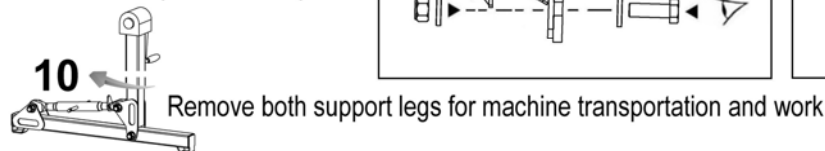
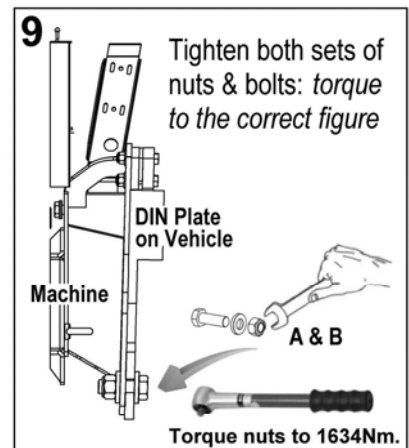
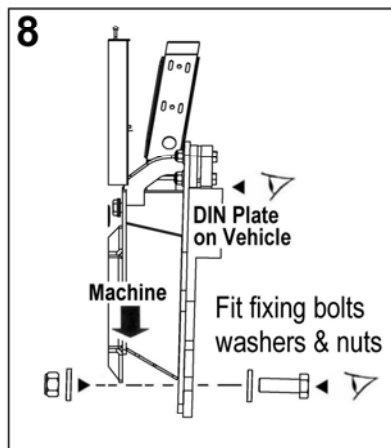
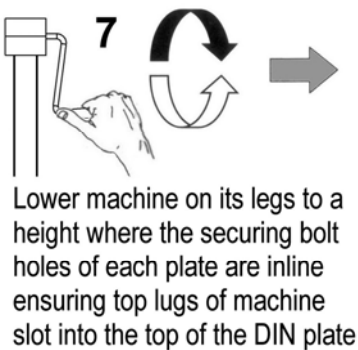
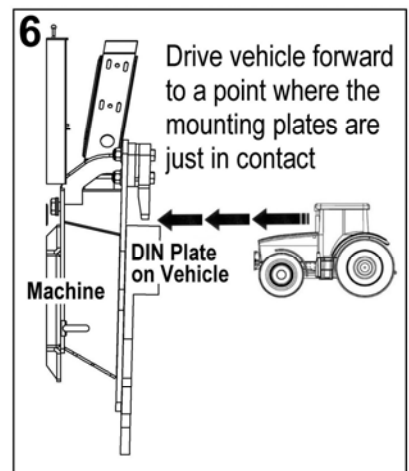
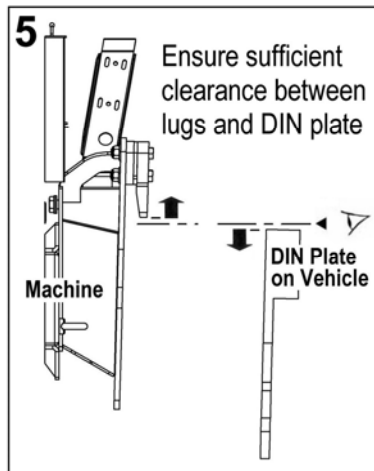
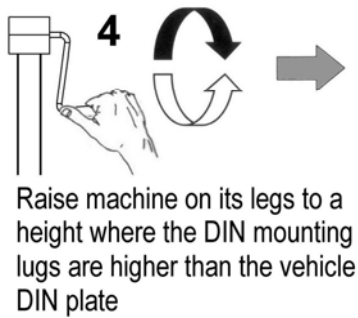
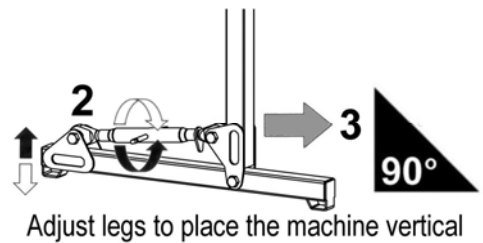
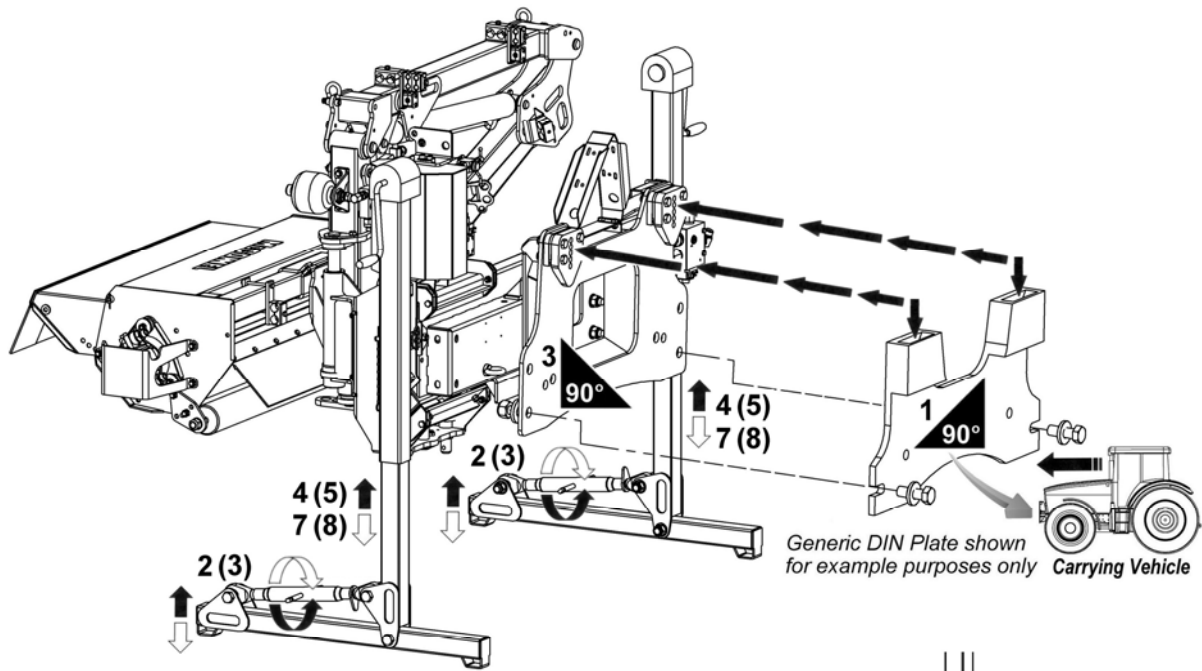

ATTACHING THE MACHINE – 3-Point Linkage Mounted Models

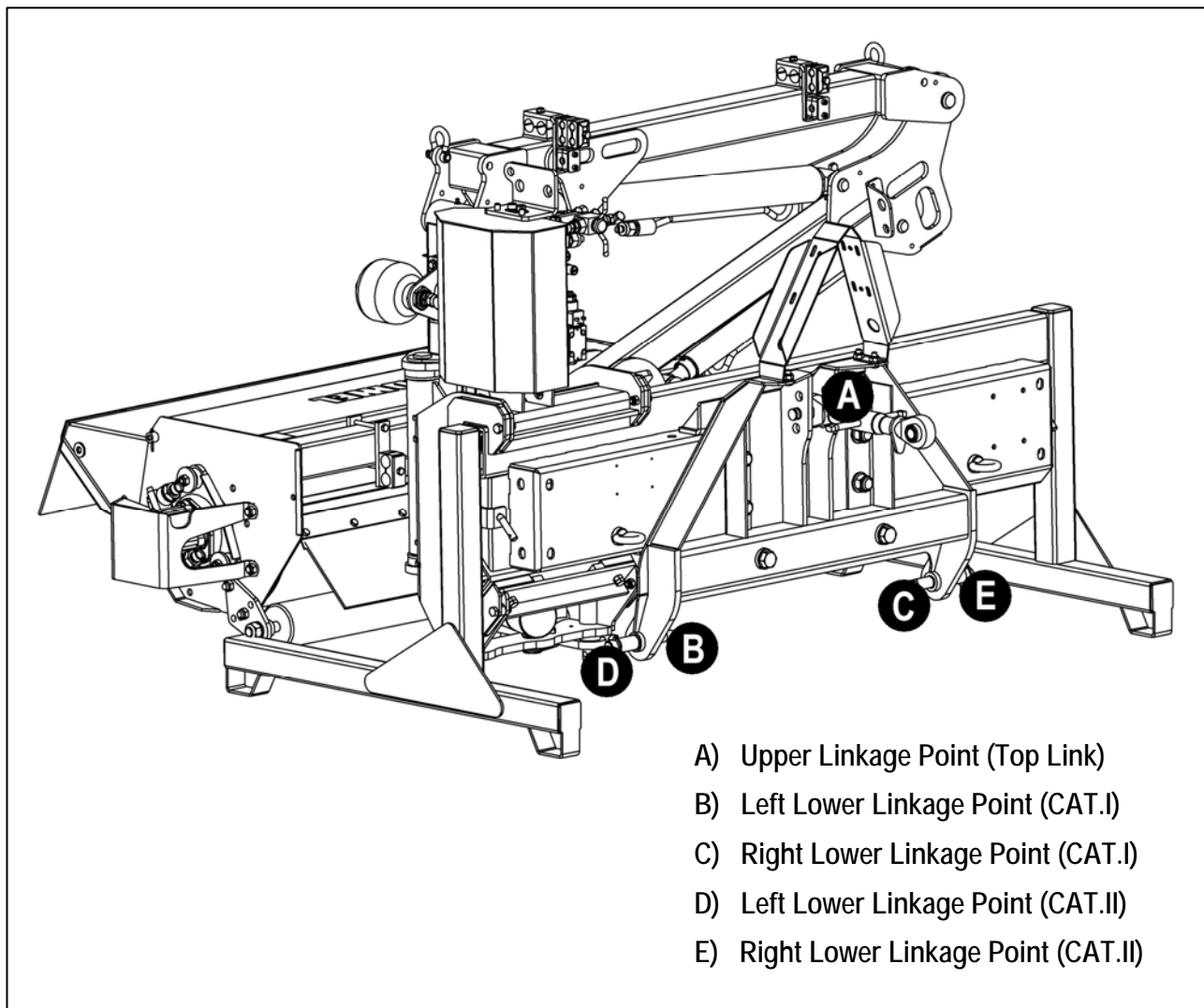

The attachment procedure must always be performed on a firm level site, never attempt to attach the machine on sloping or soft ground. Keep all bystanders at a safe distance.

Attachment Procedure

- With the machine on its stand legs, carefully drive the vehicle centrally up to the machine.
- Attach the machine lower linkage points to the vehicles lower linkage and secure with locking pins; *the machines lower linkage points allow for both CAT I & CAT II connection.*
- Fit top link between upper linkage points of the machine and vehicle; adjust to bring the machine into the vertical position.
- Fit check chains or stabilizers and tighten.
- Connect Pressure, Return & Drain Line hoses to the vehicle.
- Install operator control unit in the cab of the vehicle.
- Raise machine and remove stand legs for transportation and/or work.
- Carefully operate the machine through its complete range of movements to confirm all functions are working correctly.

Stand legs should be kept in a safe location for future re-attachment for parking or storage of the machine.

Control Unit Installation

Fit the control unit in the cab of the vehicle selecting a position that offers the user optimum ease of operation.

Main control units attach to the tractor seat armrest using the fixing straps supplied.

Feed control lines into tractor cab avoiding any sharp bends and keeping lines well clear of any moving parts on the machine or vehicle.

Flail Head Mounting

The machine is equipped with head mounting plates on both sides of the head angling mechanism; this allows the flail head to be mounted for both left and right hand operation.

For work, the flail head must always be attached to the frontal side of the arm on the operating side.

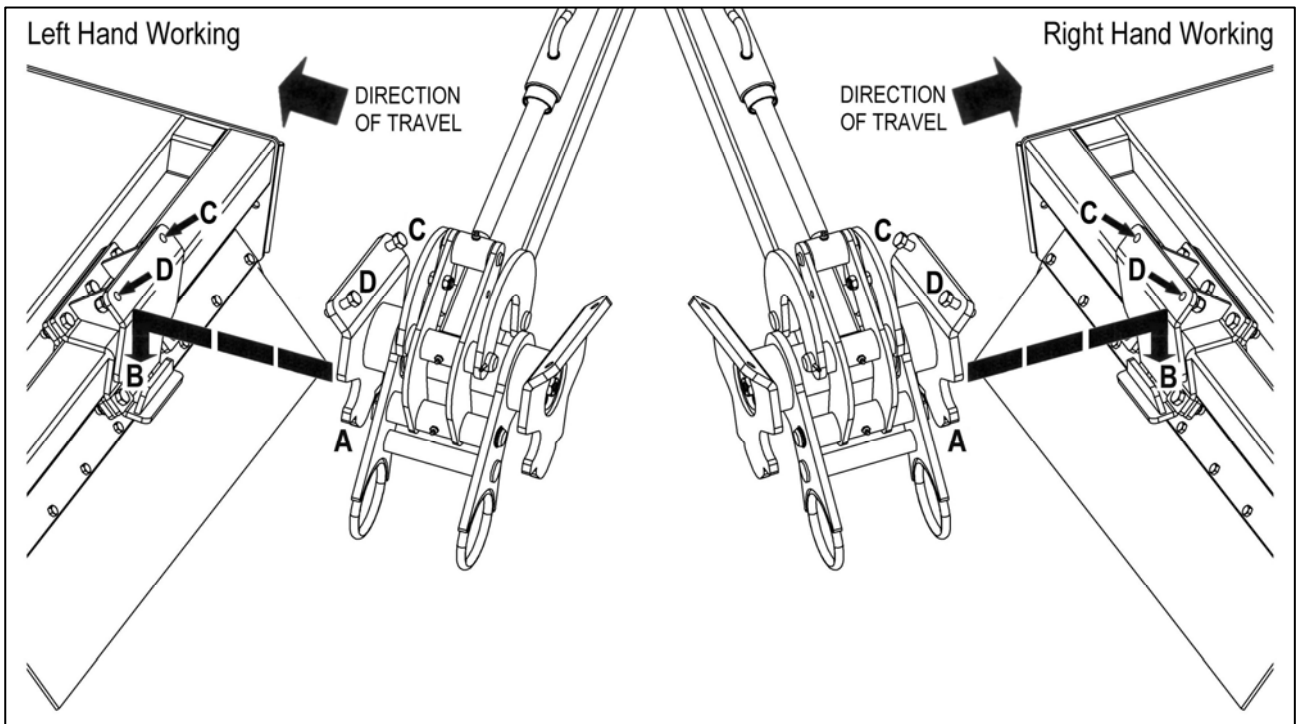

Attaching the Flail Head

Attachment of the flail head must always be performed on a firm level site; the procedure is as follows;

With the flail head facing forwards and the machine's arms placed to the required work side; position the frontal mounting plate of the head angling mechanism above and parallel to the mounting bracket on the flail head.

Move the machine's arm carefully to position the tab (A) on the base of the mounting plate into its connecting slot (B) in the base of the mounting bracket; when correctly positioned the two upper mounting holes will be aligned and the head can be secured and tightened into place with the 2 upper mounting bolts and nuts (C & D) - *ensure mounting bolts are fully tightened.*

Removal of the flail head is a reversal of the above procedure.



WARNING! Keep clear of arms and angling gear when manoeuvring the machine to attach the head; numerous pinch risk areas are associated with this part of the machine. Keep bystanders clear of the machine at all times during this procedure.

Machine Removal

Subsequent removal of the machine is basically a reversal of the attachment procedure. When parking the machine for removal or storage always select a firm level site in a safe location that will also allow for ease of future attachment. The arms should be fully folded into the machine and centrally positioned to give maximum stability and balance to the unit prior to removal. Once removed the machine should be parked on the stand legs - refer to horizontal adjustment and height section for operation of the stand leg jacks. Ensure the machine is left level and secure at all times, if necessary use suitable props or blocks for added support.

Storage

For long term storage it is recommended that the machine is sited in a clean dry environment where it is protected from the elements. Prior to storage the machine should be thoroughly cleaned and lubricated.

Ensure the machine is always stored in a safe manner and does not risk any form of danger to persons or animals.

XTC (Mk3) PROPORTIONAL SWITCHBOX CONTROLS (7 Service)

Machines with XTC Mk3 Proportional Controls (7 service) will be supplied with the control unit shown below. The units for both electric and cable controlled rotor machines are identical except that for cable versions the rotor control switches B, C & D (*shown below*) will not provide a function as rotor operation will be controlled by a separate cable lever unit (*refer to specific cable rotor control page for operation details of that unit*).

Identification & Function of Controls

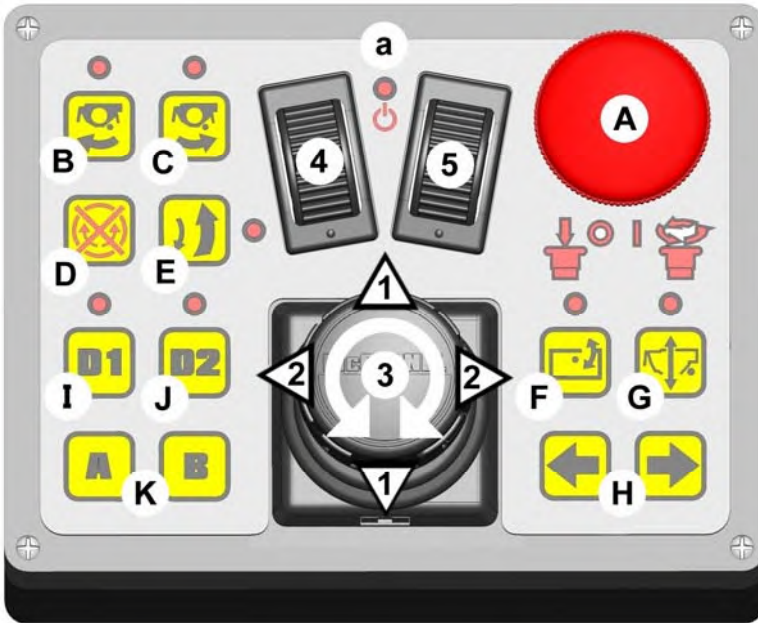

1. Arm Lift Control.
 2. Arm Reach Control.
 3. Head Angle Control.
 4. Slew Control* (Default) / 6th Service*
 5. Tele/Midcut/VFR Control.
- A. Power On/Off (LED 'a' indicates status).
 B. Rotor Start (Uphill Cutting Direction).
 C. Rotor Start (Downhill Cutting Direction).
 D. Rotor Stop.
 E. N/A
 F. Head Angle Float On/Off.
 G. Lift Float On/Off (Option).
 H. 6th Service* / Slew* (Swapped Mode).
 I. 6th Service Activation Switch
 J. 7th Service* On/Off
 K. N/A
 * If applicable

*NOTE: On machines that feature a controllable 6th service the functions are operated by default using the ◀ ▶ buttons (H), this control can be swapped to operation by the left hand thumb switch (4) by activation of the D1 control panel button; in this case Slew is then operated by use of the ◀ ▶ buttons (H). Control panel button D2 is used for any other additional services that require on/off control only i.e. Debris Blower / Diverter Valve.

LED Lights

LED lights adjacent to control button reports the status of that particular function; when the function is selected the LED light will illuminate to confirm that the function is active; the light will switch off on de-selection of the function.

Powering the Controls

Activation of power to the control unit is by operation of the red button switch as shown below:

Rotate clockwise for **Power ON**
 (LED light on confirms power on)



Press for **Power OFF / Emergency Stop**
 (LED light off confirms power off)



ARMHEAD OPERATION

Left Hand Operation

Right Hand Operation

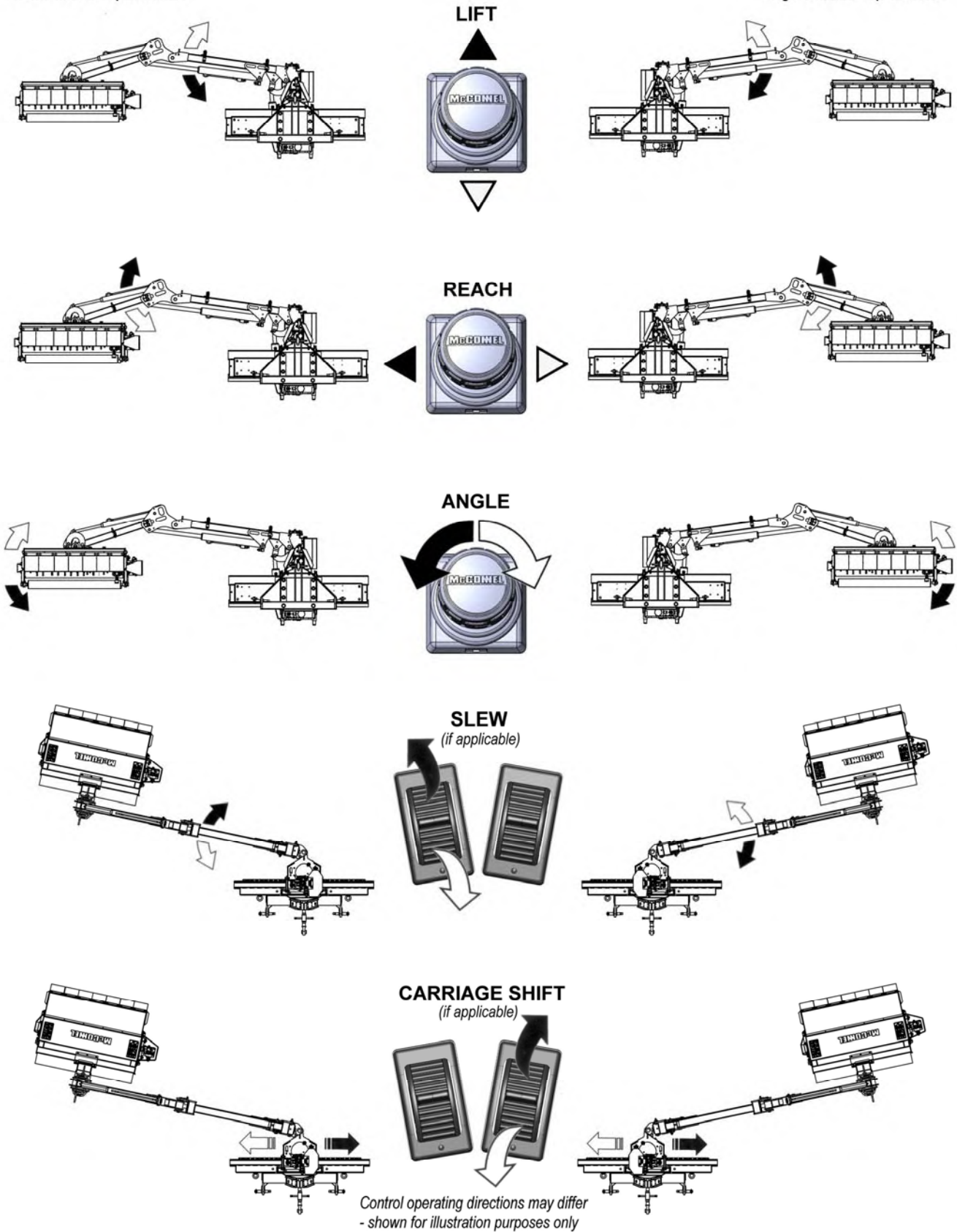

CAUTION! All operators should practice using the machine in a safe open location with the rotor switched off to familiarise themselves with the controls and functions before attempting to use it in a working environment.

6th SERVICE (Where applicable)

Default Mode

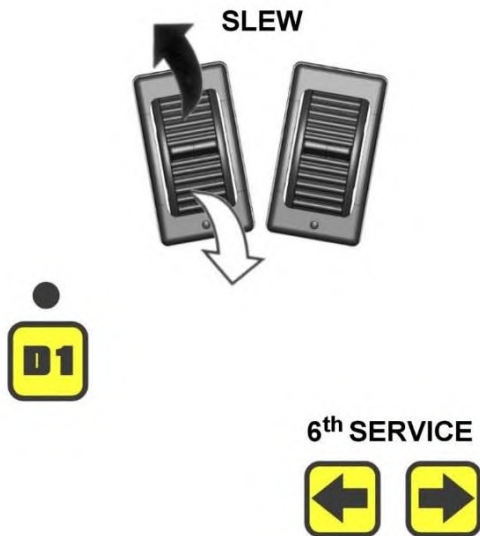

Swapped Mode (D1 Activated)

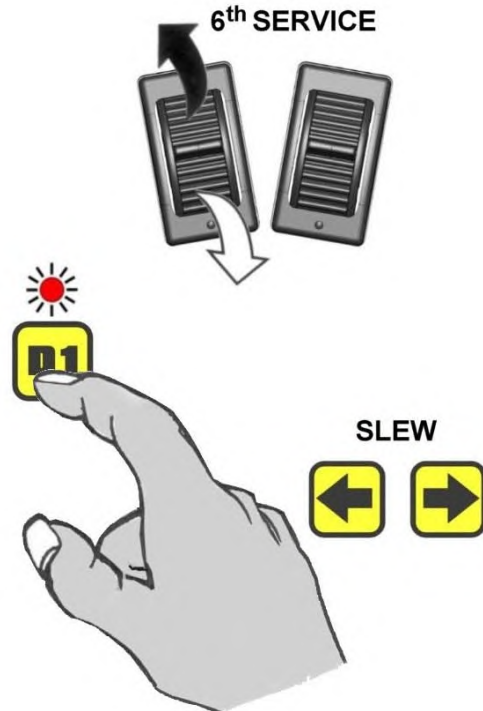

On machines fitted with a controllable 6th service default operation of that function will be via the ◀ ▶ buttons on the control unit. If required, control of the function can be swapped to the left hand toggle switch by activating the D1 button on the control panel; in this mode slew operation will then be transferred to the ◀ ▶ buttons. De-activating D1 will return the functions to their default controls. An LED light above the button confirms when the service is active.

7th SERVICE (Where applicable)

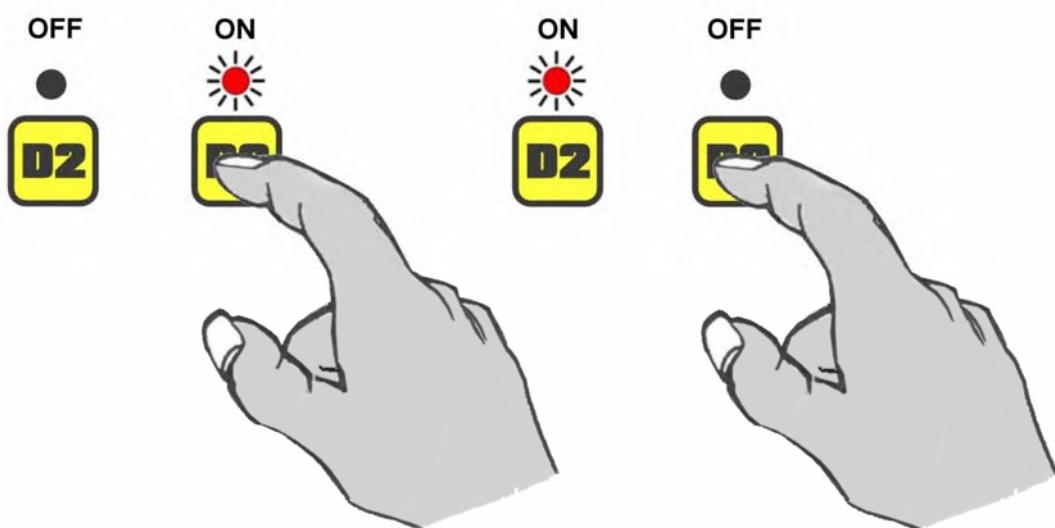

Additional services that require ON/OFF control only are operated by the D2 button on the control panel; pressing the button will switch the service on, pressing the button again will switch it off. An LED light above the button confirms when the service is active.

HEAD FLOAT OPERATION

Angle Float (Standard)

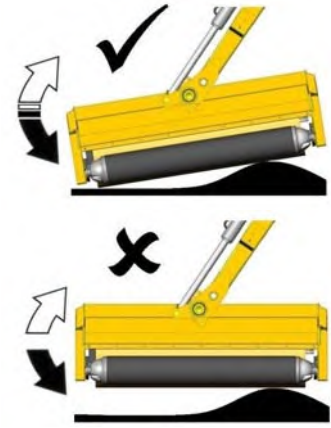
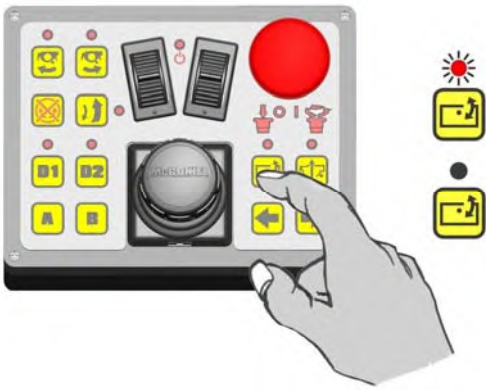

Lift Float (Optional)

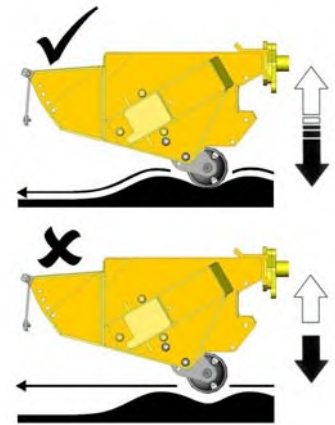
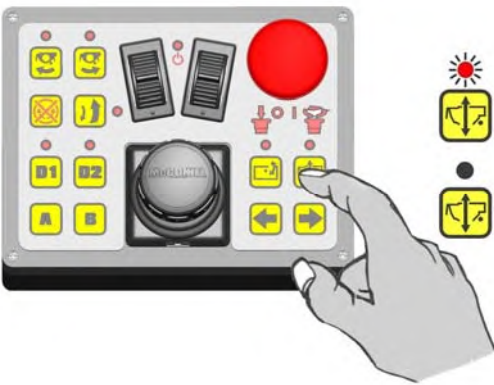

ROTOR OPERATION

Rotor Start (Selection of Rotor Cutting Direction)

Select rotor start for required direction (LED will light to indicate the active direction).

Uphill Cutting

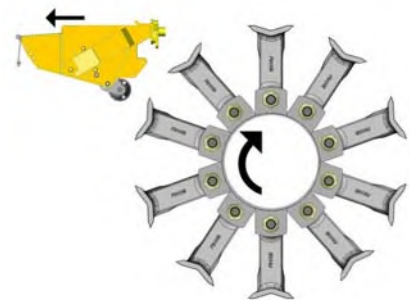
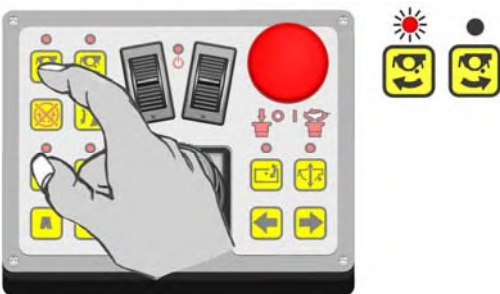

Downhill Cutting

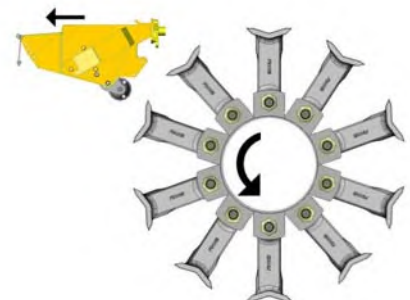
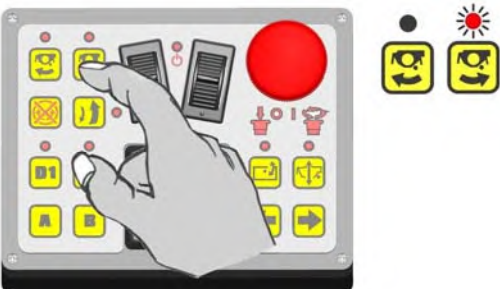

Switching Rotor Direction

With the rotor running, changing the rotor cutting direction can only be achieved after first operating 'rotor stop', when stop has been selected the specific direction button can then be operated to command the rotor to switch to the desired direction. NOTE: This function has a built in time delay of approximately 8 seconds - this is a machine protection feature that allows the rotor sufficient time to de-accelerate before restarting in the opposite direction. The LED light of the active cutting direction will flash on and off during the slowing down period, when the direction has changed the LED for the new direction will be illuminated.

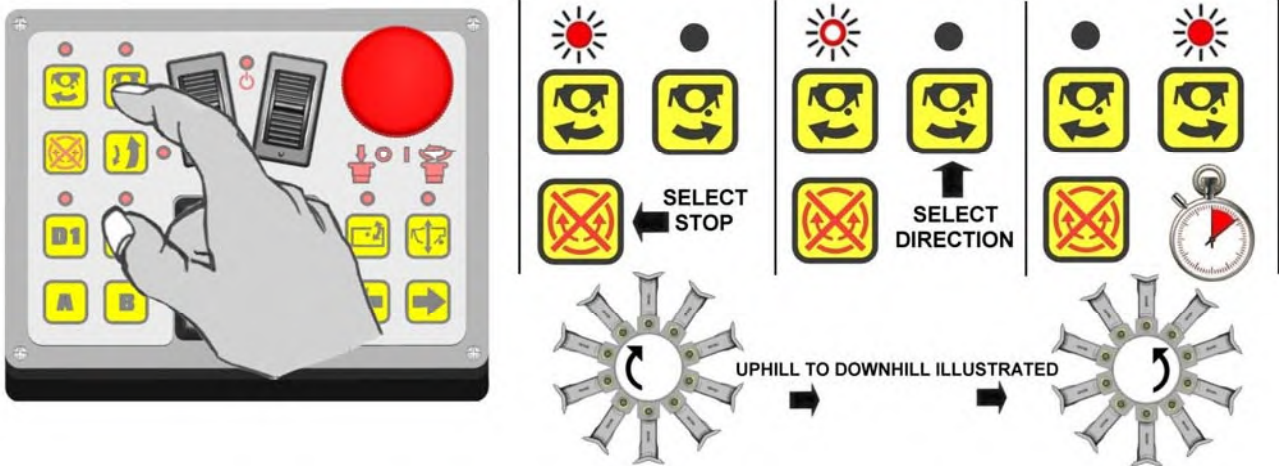

Switching the Rotor Off

Stopping the rotor is performed by operation of the rotor stop button as illustrated below. When 'rotor off' has been selected the LED light above the button of the active cutting direction will flash on and off at an increasing frequency for approximately 8 seconds to signify that the rotor has been switched off, after this 8 second period the light will go off completely. NOTE: The rotor will continue to rotate under its own power until it finally comes to a standstill.

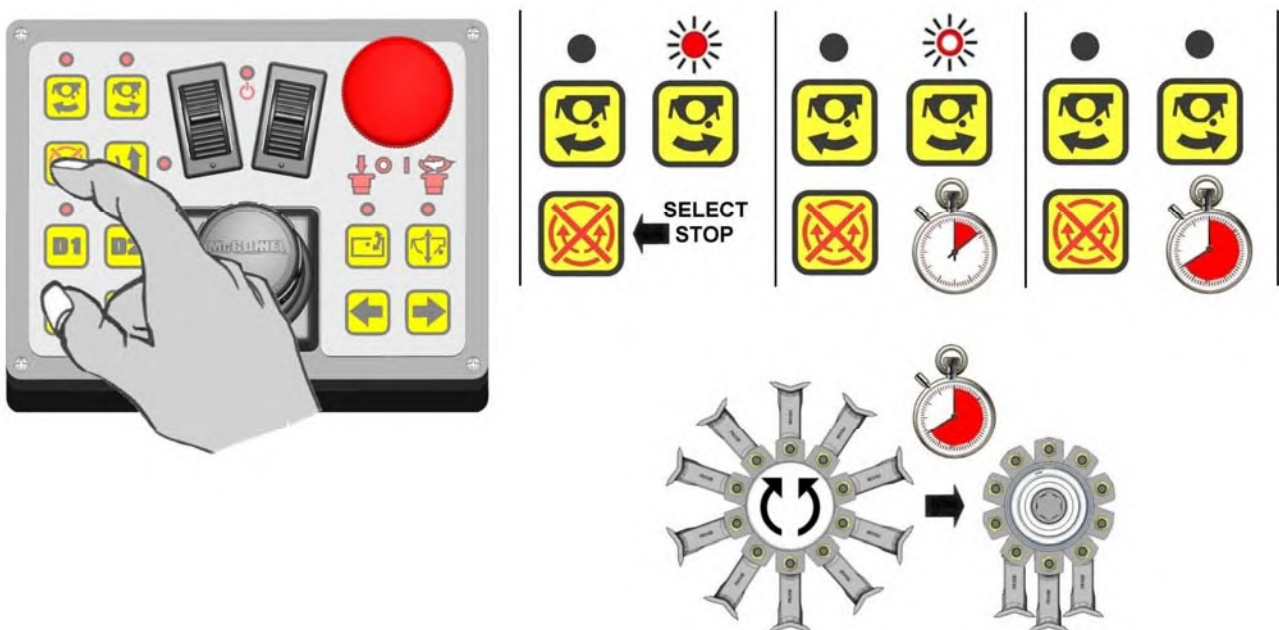

CAUTION: When the rotor is switched off it will continue to 'freewheel' under its own momentum for up to 40 seconds before finally coming to a standstill – do not leave the tractor cab or attempt to approach the flailhead until the rotor has stopped turning completely.

CONTROL UNIT CALIBRATION

If for any reason the controls should stop responding the unit will need to be calibrated; the procedure for this is shown below.



With the unit powered off; simultaneously press and hold both rotor direction buttons before then powering on the unit.



When all the led's light up; release both buttons.



Press and release the rotor stop button to enter calibration mode; all led's will simultaneously flash once to confirm.



Power led will flash on and off continuously whilst the unit is in calibration mode.

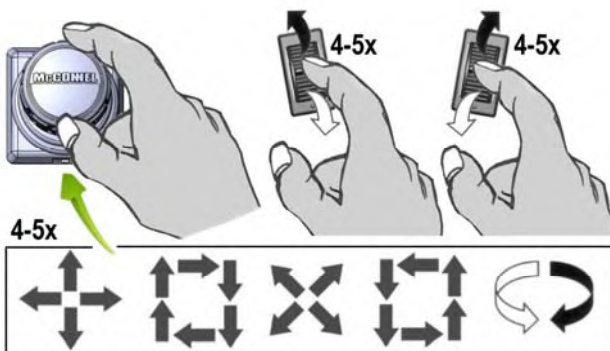

Operate the joystick through its complete range of movements 4 to 5 times then operate each toggle switch fully forwards and fully backwards 4 to 5 times.

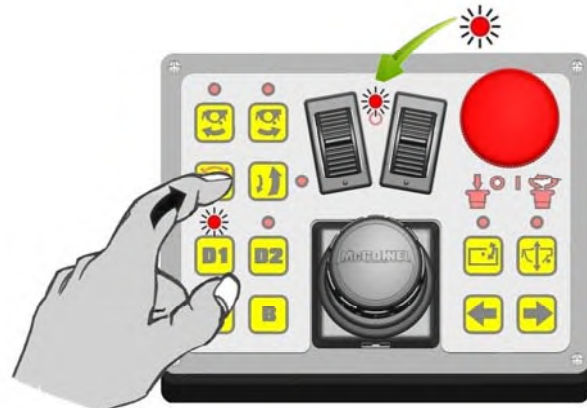

Press the rotor stop button once to exit calibration mode; the rotor stop led will flash rapidly to confirm and the power led will stop flashing and remain lit.

MINI MOTION CONTROLS

Power ON

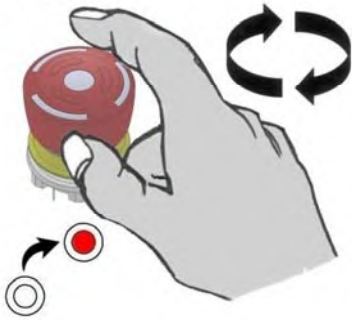

Power OFF / EMERGENCY STOP

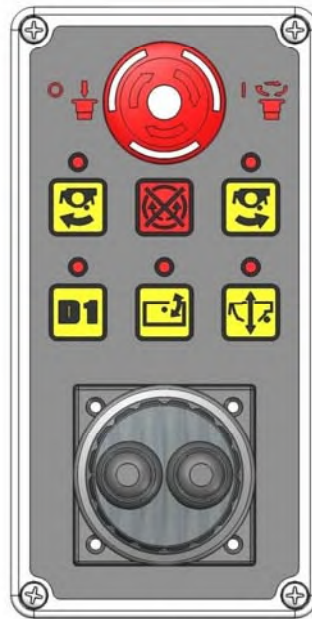
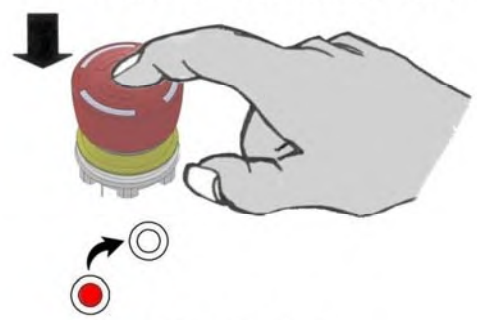

Default Control:
 X Axis: Lift Operation
 Y Axis: Reach Operation
 Z Axis: Angle Operation
 B1+Z Axis: Slew Operation
 B2+Y Axis: 5th Service

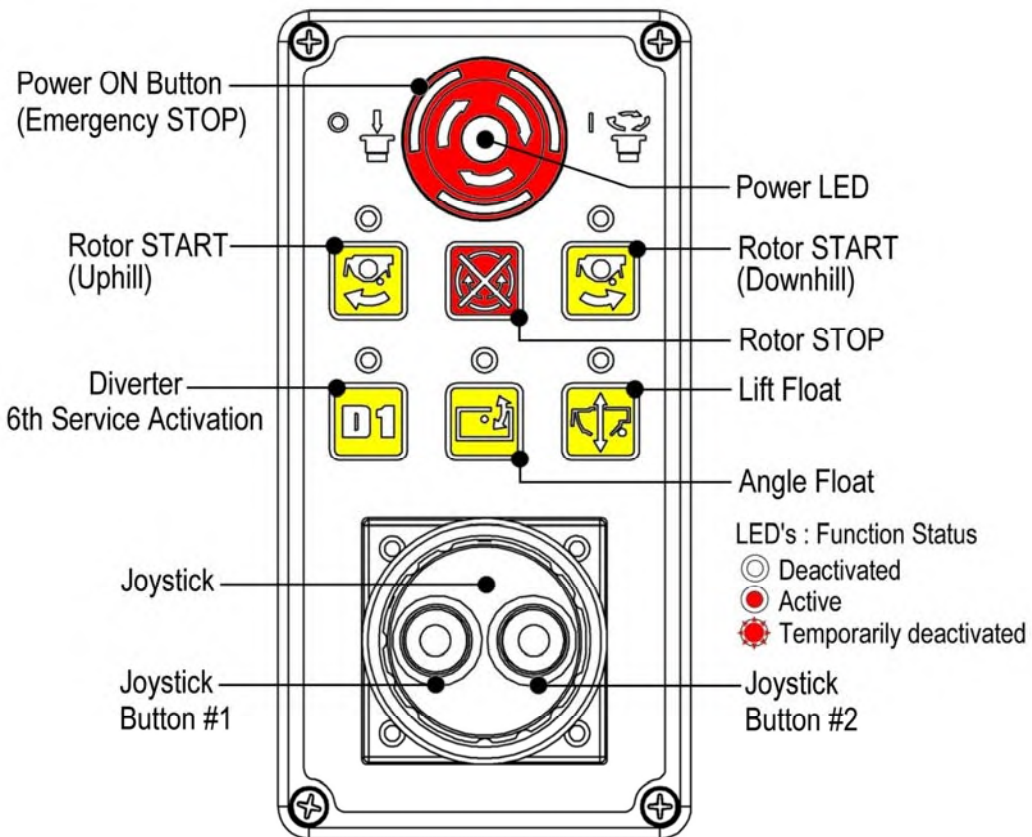
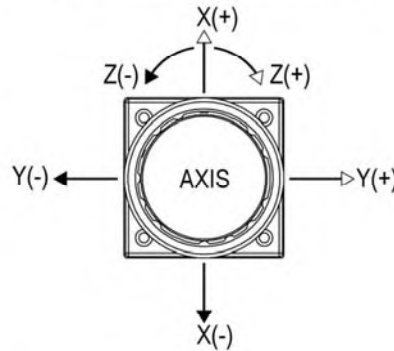

Arm Operation Controls

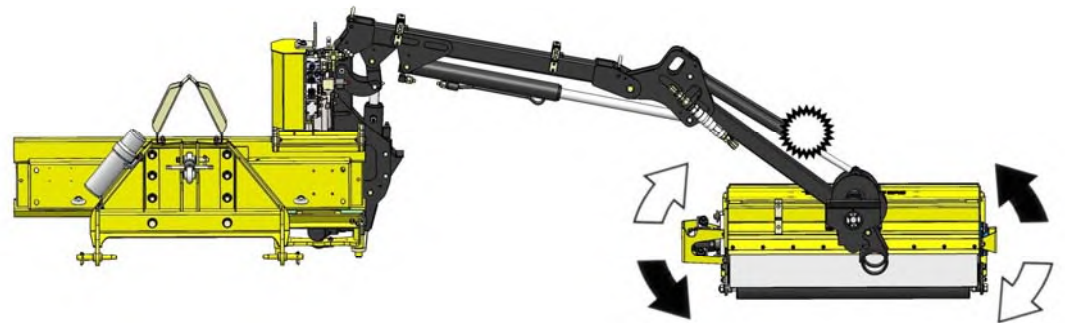
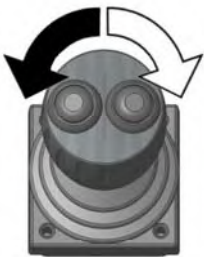
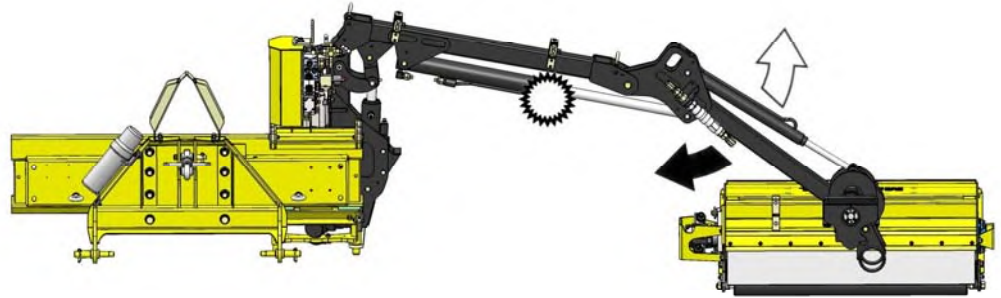
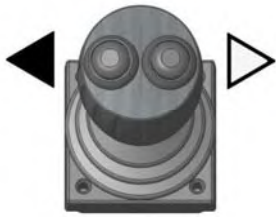
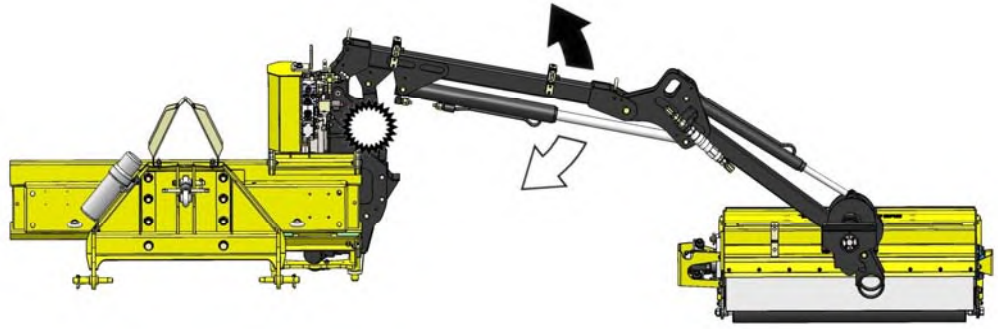

B1*
*Press & Hold



+

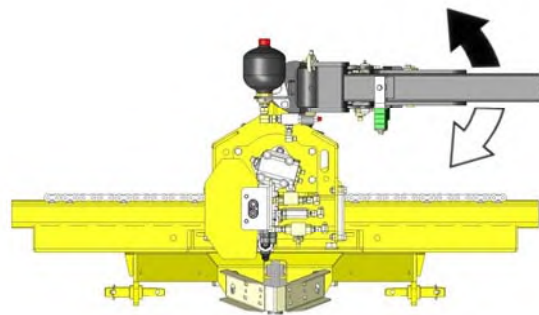







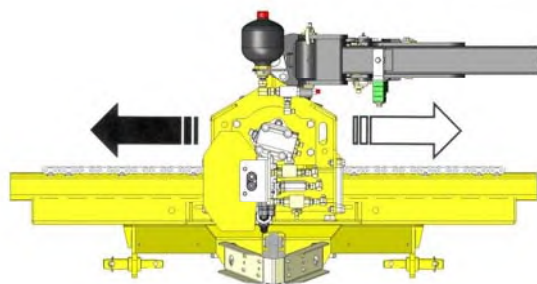
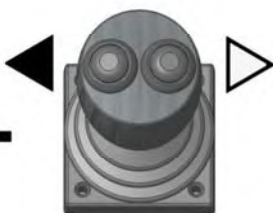

B2*
*Press & Hold



+



Keypad Control Buttons

Button	Function	Control Operation
	Angle Float ON/OFF	Pressing the button will switch Angle Float function ON/OFF.
	Lift Float ON/ OFF	Pressing the button will switch Lift Float function ON/OFF.
	Rotor START (Uphill Direction).	Press to START rotor in uphill direction. <i>8 second delay for direction change.</i>
	Rotor START (Downhill Direction).	Press to start rotor in downhill direction. <i>8 second delay for direction change.</i>
	Rotor STOP.	Press to stop rotor. <i>Press first before direction change.</i>
	Diverter: 6 th Service Activation	Press to switch 6 th Service ON/OFF.
	Function status - OFF.	LED Light for specific control OFF.
	Function status - ON.	LED Light for specific control ON.
	Function status - Temporarily deactivated.	LED Light for specific control FLASHING.

FLOAT OPERATION

Angle Float ON/OFF

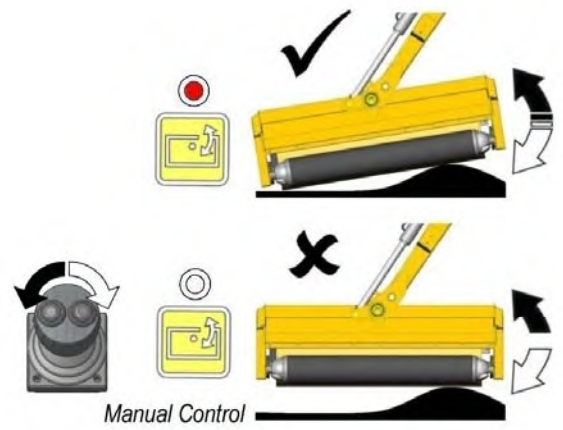
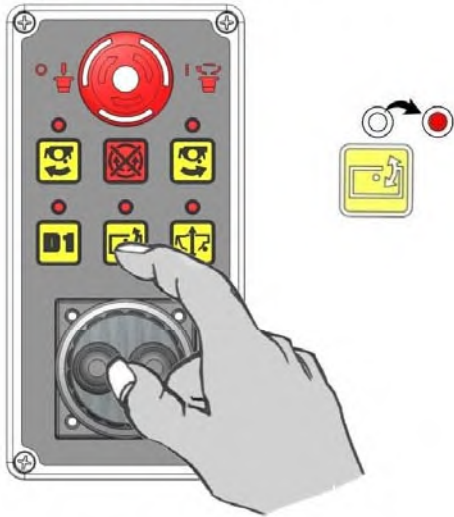

Lift Float ON/OFF

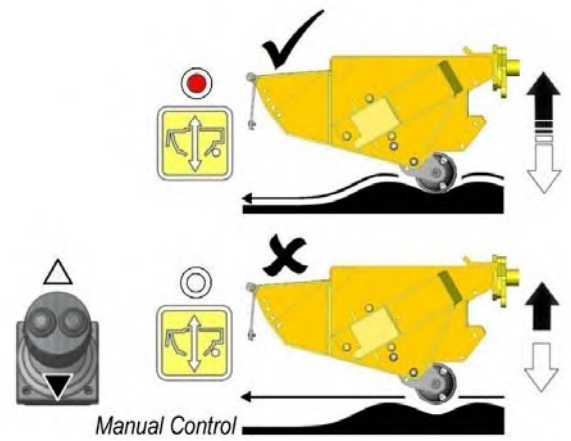
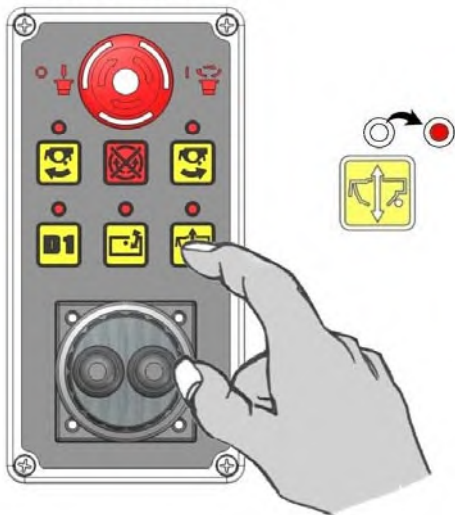

ROTOR OPERATION

Rotor Start - Uphill Cutting

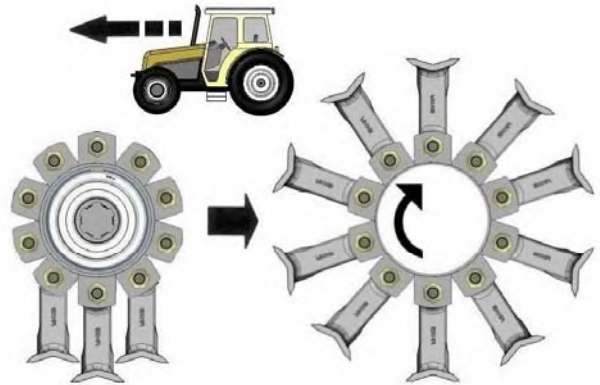
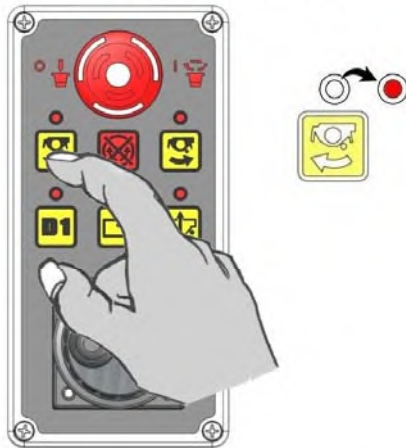

Rotor Start - Downhill Cutting

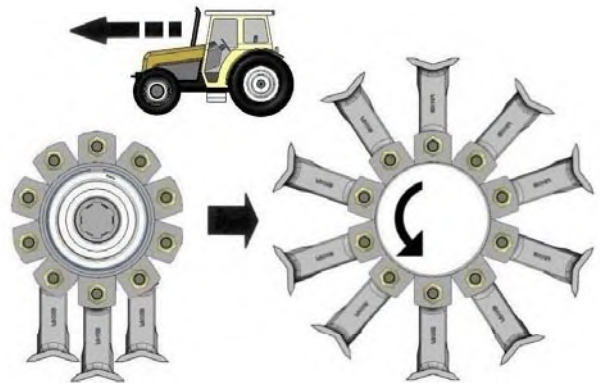
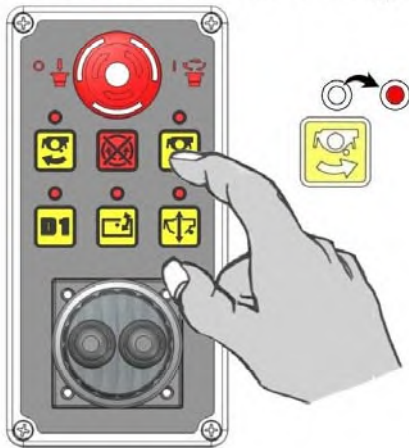

Rotor Stop (Uphill or Downhill)

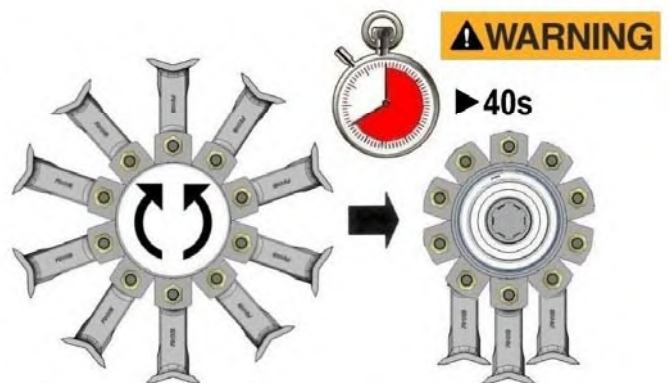
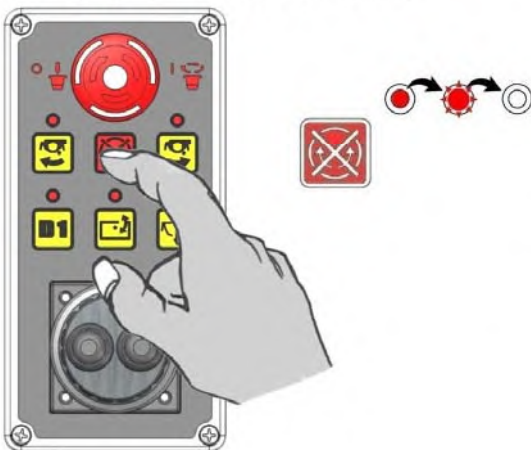

WARNING



When the rotor is switched off it will continue to 'freewheel' under its own momentum for up to 40 seconds before finally coming to a standstill – do not leave the tractor cab or attempt to approach the flailhead until the rotor has stopped turning completely.

RUNNING UP PROCEDURE

The running up procedure should be performed in a safe location clear of hazards. Keep bystanders at a safe distance at all times.

- Check machine is correctly installed on the vehicle and that all connection pins are secured with locking pins.
- Check Pressure, Return and Drain Line hoses have been correctly attached to the vehicle.
- Ensure work position strap is correctly fitted.
- Check breakback ram is primed and the 'pressure' and 'return' taps on the breakback ram circuit are both in the closed position.
- Ensure that the rotor control is in the 'stop' position.
- Start vehicle and allow oil to circulate without any operation; inspect hydraulic connections to confirm there are no signs of oil leaks.
- Operate armhead controls to move the arms through their complete range of movements ensuring that all are functioning correctly.
- Operate the machine carriage to ensure 'side to side' operation functions correctly.
- Check the hose runs and ensure they are free from any pinching, chaffing, straining or kinks.
- Place the flail head at a safe attitude and 'start' the rotor, after initial fluctuation the rotor should settle to a steady speed. Increase speed and run for a further 5 minutes before disengaging the rotor and stopping the vehicle.
- Check all hydraulic hoses and connections to confirm there are no signs of leaks.

EMERGENCY STOPPING

In all emergency situations machine operation and functions must be stopped immediately; **Stop Operation** using the tractor controls then immediately kill electrical power to the machine using the **Off (Emergency Stop)** switch on the machine's control unit.



WARNING:

Always ensure that electrical power to the machine is switched off using the **Off (Emergency Stop)** switch on the machine's control unit in emergency situations and/or when the machine is not being operated.



WARNING:

In certain conditions the arm sets on machines possess the potential to move unintentionally, even when the machine is switched off and stationary, if levers were accidentally operated. Care must be adopted to avoid any movement of the levers when the machine is not being operated. Ensure arm sets are lowered fully to the ground when machine is parked up or not in use.

TRANSPORTION

Transport Position

For machine transport the flail head should be set parallel to the arms and the carriage moved to its furthestmost position on the left hand side of the machine; the dipper arm can then be fully folded into the main arm and the latter positioned horizontally as illustrated opposite. In this position the machine is not only stable and compact but also offers maximum forward visibility to the driver for ease of transportation and manoeuvrability.

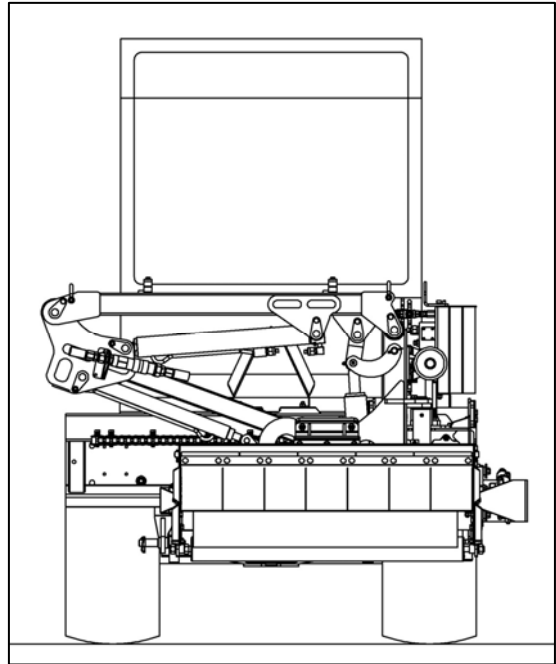

Moving into Transport Position

The procedure for moving the machine into the transport position is as follows;

- Operate 'lift up' to fully raise the main arm.
- Operate 'reach in' to fully fold the dipper arm into the main arm.
- Operate 'carriage shift' to move the carriage to the fully left side of the machine.
- Operate 'lift down' until the dipper comes into contact with the arm support bracket on the pillar and operate 'angle' to bring the flail head into the horizontal position.

Moving from Transport to Work

Moving from transport into work is basically a reversal of the above procedure. Always ensure when moving out of transport that 'lift' is the first control operated; this will also ensure the flail head remains clear of the ground during subsequent movements.

Transport Height & Width

The design of this machine is such that when correctly folded its transport height will be below the height of the carrying vehicle.

When correctly folded for transport the maximum width of the machine, *without head attachment fitted*, is approximately 1.6m for PA3430 models and 1.9m for PA4030 models.

Depending on the dimensions of the particular head attachment fitted, the transport width figure may be increased; therefore during transportation the operator should always be aware of the specific dimensions of their machine and always drive with due care and attention at all times.

Transport Speed

The acceptable speed whilst in transport will vary greatly depending on ground conditions; the maximum recommended speed is < 20mph. In all conditions avoid driving at speeds which cause exaggerated 'bouncing' as this will put unnecessary strain on both the tractor and machines components.

MANUAL SLEW & BREAKBACK PROTECTION SYSTEMS

Machines feature a manual slew system allowing the arms to be placed and then operated in a selection of fixed work positions; the choice of positions are at 0°, 30° forward and 60° forward, and apply to both left and right hand operation. *Note; 30° and 60° forward work positions can only be used if the machine is equipped with a rotating head mounting.*

Selection and setting of the required position is by use of the strap that locates on the base of the machine; this work position strap has a choice of 3 hole positions for attachment to a restraint peg located on the base of the pillar and a slot at the opposing end that locates on either the left hand or the right hand working restraint pegs on the base of the sliding carriage; the specific hole selected will determine the work position, the slot is designed to provide 17.5° of 'breakback' movement to protect the arm set should the machine come into contact with an immovable object.

The 'work position strap' must always be fitted to the machines for both work and transport; never attempt to use the machine without the strap correctly fitted.

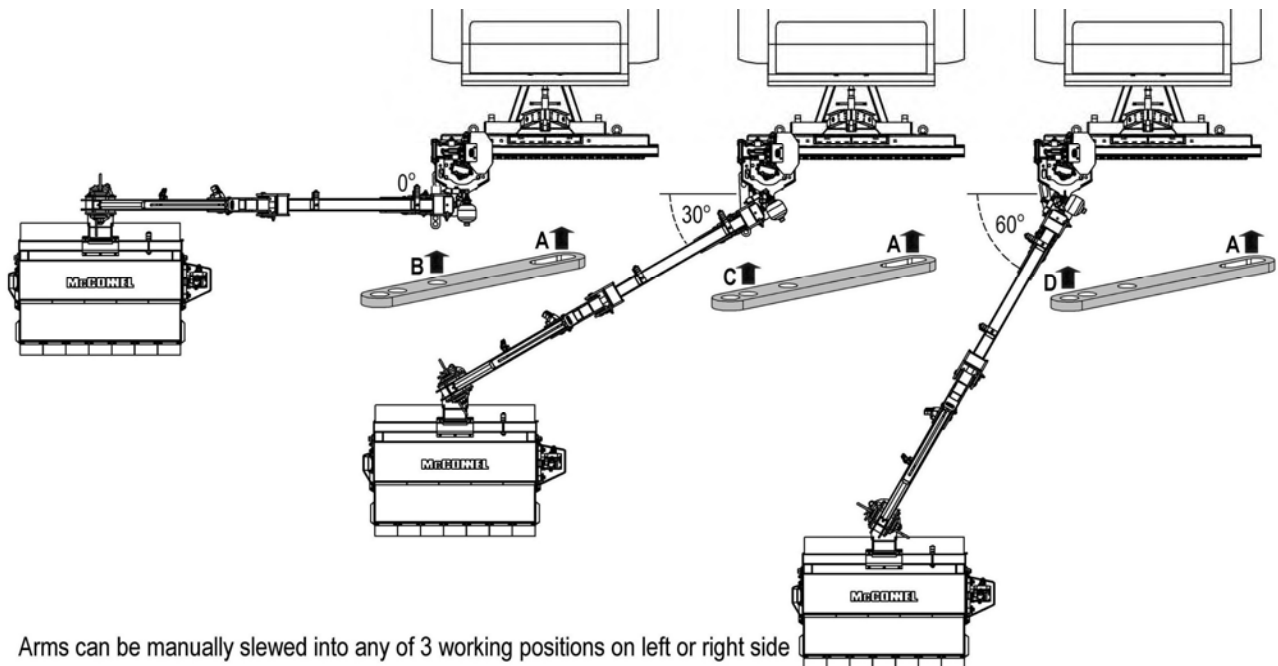
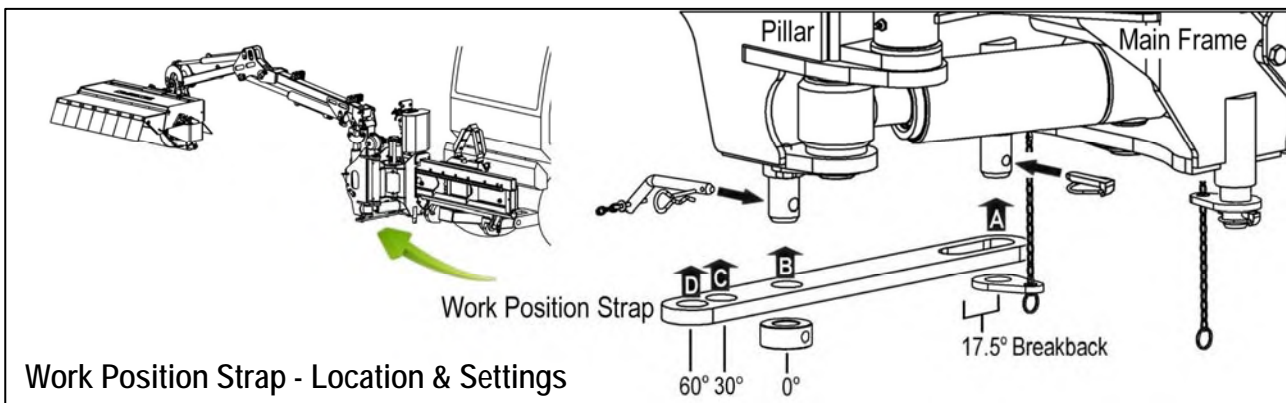

Breakback System

The breakback system is designed to offer protection to the structure of the machine if it comes into contact with an immovable object during forward movement; in the event of 'breakback' occurring the arm set is allowed to move backwards by up to 17.5° giving the operator an opportunity to halt forward movement. When breakback occurs the arm must be manually returned to the work position; refer to 'Priming Breakback' page for details.

NOTICE

The breakaway function does not relieve the operator of their responsibility to drive carefully; always be alert and avoid obvious hazards before contact occurs.

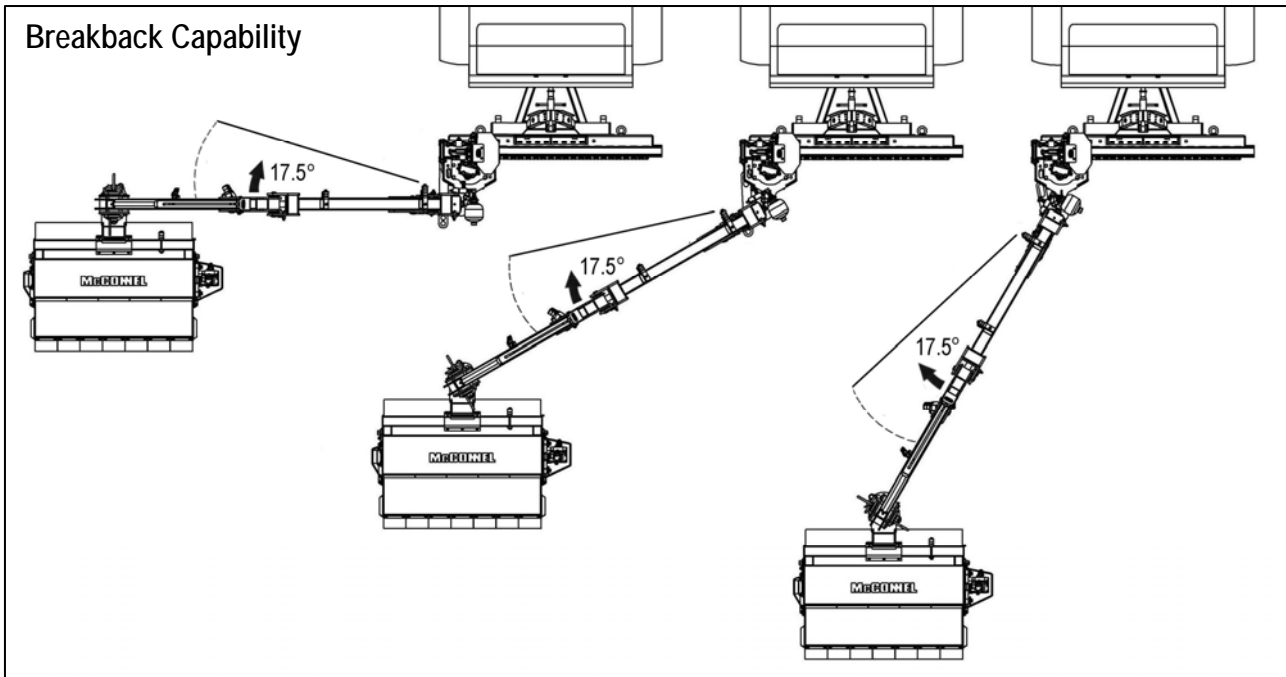

Priming Breakback

During normal operation the arms of the machine are held in the work position by hydraulic pressure stored in the breakaway ram; the system features a relief valve that is designed to release the pressure when the machine encounters a measured force allowing the arm set freedom to breakback.

After breakback has occurred the system must be manually reset.

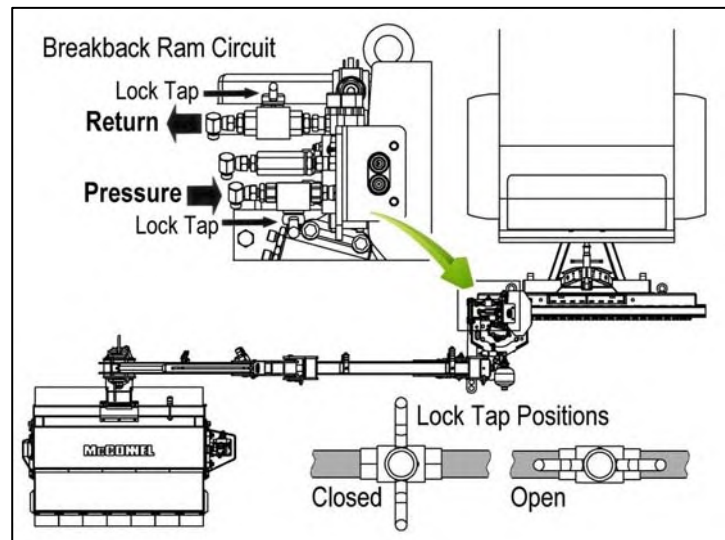

The procedure for 'priming' the breakback system for work is as follows:

- Work position strap must be correctly fitted for the required working position.
- Open 'pressure' tap on breakback circuit; *pressurise ram until arm is held fully forward.*
- Close 'pressure' tap.

Swapping Operating Side

The procedure for moving the arms to work on the opposing side is as follows:

- Park machine on a firm level site.
- Open 'return' tap on the breakback circuit (keep 'pressure' tap closed).
- Remove work position strap from base of machine.
- Manually swing the arm to the required position.
- Replace work position strap at the required position.
- Close 'return' tap.
- Prime the breakback system – *refer to priming section.*
- Remove flail head and re-fit to the frontal mounting plate on the arm.

ANGLE FLOAT KIT (Standard Feature)

Machines are fitted with Angle Float as standard – when activated the feature connects the base and gland circuits of the angle ram to allow free movement of oil in both directions thus allowing the head to automatically angle itself to match the contours of the ground.

Refer to specific controls section for details of operation.

NOTE: On machines with 'Revolution' proportional controls any operation of the angle float thumbwheel will override and de-activate the automatic angle float function, on release of the thumbwheel it will revert back to automatic angle float.

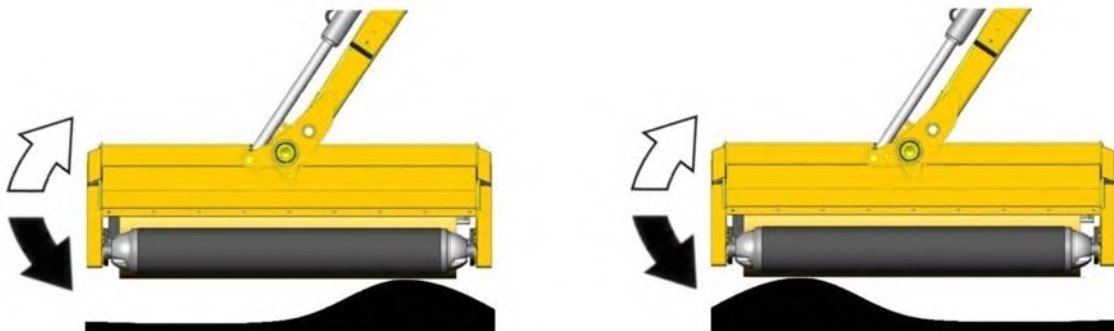

Angle Float Off – Requires operator input to adjust flail head angle

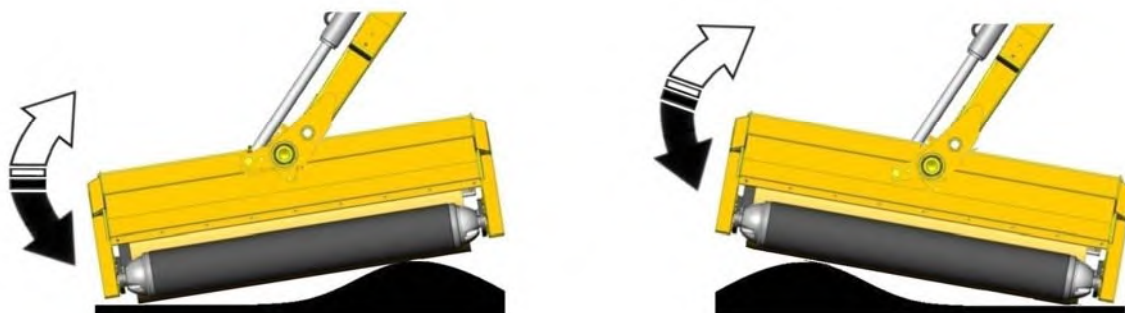

Angle Float On – Flail head automatically angles itself to match the ground contours.

LIFT FLOAT (Optional Extra for Ground Work)

Work without lift float requires far more concentration and input from the operator to quickly react and re-adjust to the ground contours often resulting in patches of higher cut material where the head is cutting too high and ‘scalping’ of the ground where it is cutting too low – *in the case of the latter this can lead to increased flail wear, damage or even loss of flails.*

The Lift float feature is an optional extra for use during mowing work. When the function is activated the pressurised accumulator(s) work in conjunction with the valve and lift ram to take a proportion of the flailheads weight off the flail roller allowing the head to automatically follow the natural contours of the ground; this produces a cleaner more uniform cut without the need for constant operator re-adjustment.

Operation of the lift float function is as follows: with lift float switched off, position the flailhead approximately 1m clear of the ground before switching the float function on to charge the accumulator(s) – *the arms may drop at this point depending on the current level of retained pressure.* Lower the flailhead into the work position, release the lift control and proceed to work. **NOTE: occasional operation of the lift function will be required when working on downhill or uphill slopes and when reaching in or out in order to replenish the oil level within the accumulator(s) to retain optimum float capability.**

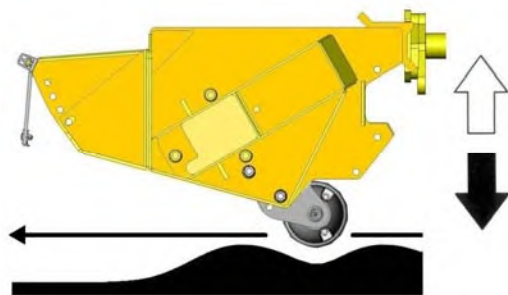

Without Lift Float
- Will require constant operator input.

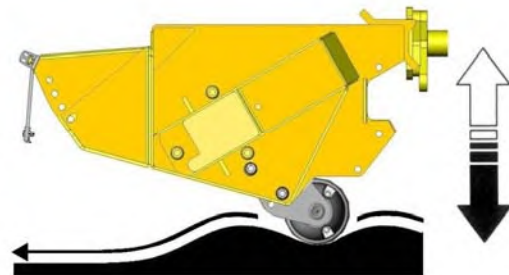

With Lift Float
- Automatically follows ground contours.

Lift float operation when supplied as a factory fitted option is controlled from the controls unit that accompanied the machine (*refer to controls section for details*), but the feature is also available for a range of models as an aftermarket kit,

Power Connections

On electric controlled machines power to the unit is via the following connections:

Machines with 14 core looms use connection 10 and common connection 11.

Machines with 19 core looms use connection 15 and common connection 16.

PRE-WORK PREPARATION & PRECAUTIONS

IMPORTANT: Always read the book first before attempting to operate the machine – practise operating the machine, without the rotor running, in a safe open space until you are fully familiar with all controls and functions of the machine. Only begin using the machine for work when you are confident that you have mastered the controls and operation sufficient for safe use of the machine.

Pre-work Machine Checks

Prior to use of the machine always check all bolts are tight and that the torque figures are correct for the specific locations indicated below:

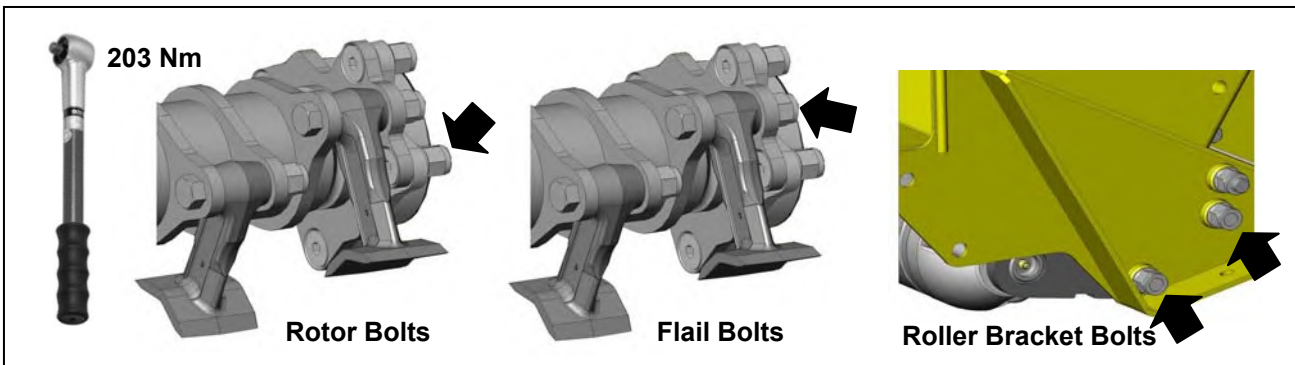
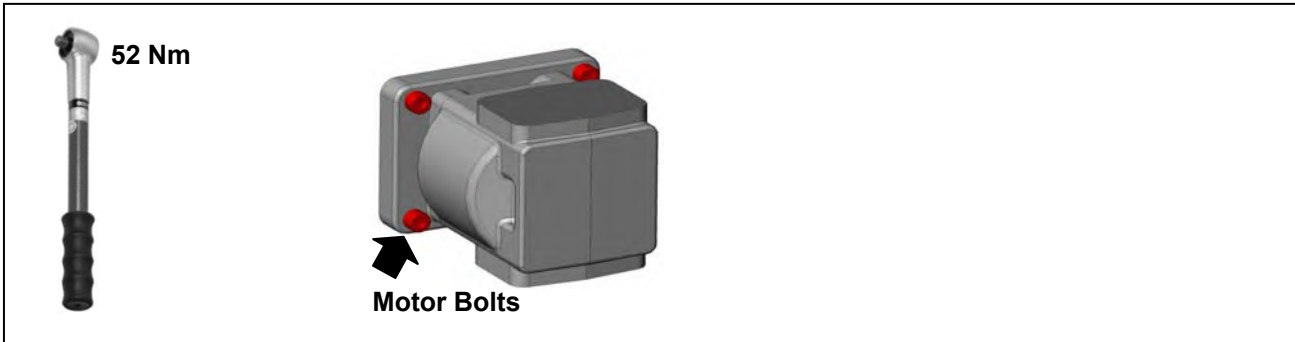

General Work Precautions

Inspect the work area prior to operation, remove any hazardous materials and note any immovable objects - *it may also be a wise precaution to mark these hazards with a visible marker than can be easily seen from the operating position in the tractor.*

If the type of work being undertaken makes this important precaution impractical, always maintain a high degree of alertness and restrict the tractors forward motion to a speed that allows sufficient time to stop the tractor or avoid the hazard before contact is made.

General Working Practice

It is the operator's responsibility to develop safe working procedures;

Always:

- ▲ Be aware of potential hazards in the vicinity of the work area.
- ▲ Ensure all guards are fitted correctly and in good condition.
- ▲ Switch off the machine before stopping the vehicles engine.
- ▲ Wait until the flail has stopped running before leaving the tractor seat.
- ▲ Switch off the machine, stop the engine, remove and pocket the key before making any adjustments to the machine.
- ▲ Check frequently that all nuts and bolts are tight.
- ▲ Keep bystanders at a safe distance.

OPERATING PROCEDURE

Starting Work

- ▲ Allow the oil to circulate for a minute or so before operating the armhead controls.
- ▲ Move the flail head into a safe working position just clear of the material to be cut.
- ▲ Increase engine speed to a high idle and start the rotor – after initial ‘surging’ the rotor will run at an even speed.
- ▲ Carefully lower the flail head into the work area and begin work.

Tractor Forward Speed (Mowing Work)

The material being cut will determine the tractor forward speed. Forward speed can be as fast as that which allows the flail head sufficient time to cut the vegetation both efficiently and neatly.

If forward speed is too fast this be indicated by over frequent operation of the breakaway system, a fall off in tractor revs and a poor untidy finish to the work leaving ragged uncut tufts and poorly mulched cuttings.

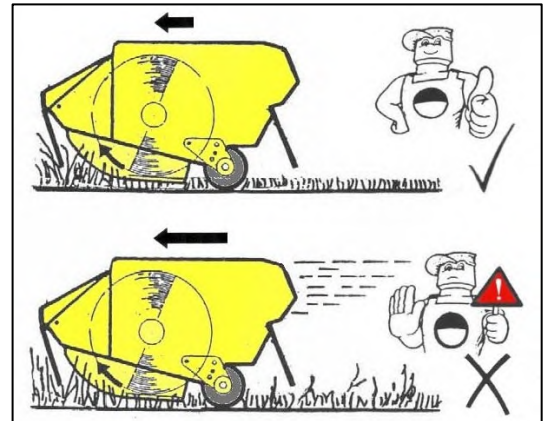

‘Running In’ a New Machine

For the first days work with a new machine it is recommended that tractor forward speed is restricted to 3 km/hr (2 mph) maximum. This will allow machine components ‘bed in’ and allow the operator to become familiar with the controls and their response under working conditions whilst operating at a relatively slow speed. If possible, select a first days work that affords mainly light to average cutting with occasional heavy duty work – *during this period check the tightness of nuts and bolts every hour, retightening as and when required.*

First day use - check tightness of nuts & bolts hourly ►

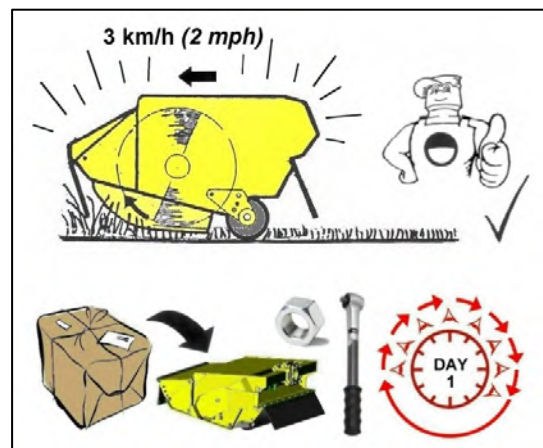

HEDGECUTTING PROCEDURE

Cut the side and bottom of the field side first. This leaves the maximum thickness of hedge on the road side to prevent the possibility of any debris being thrown through the hedge into the path of oncoming vehicles.

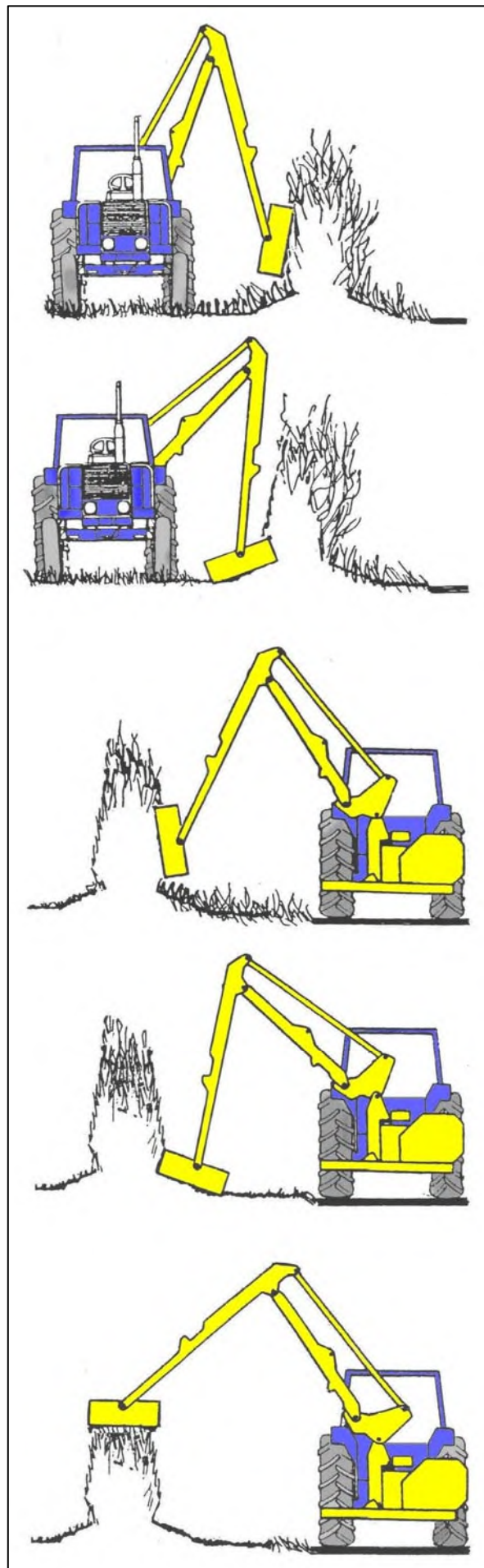

Cut the side and bottom of the road side.

Top cut the hedge to the height required.

HAZARDS & DANGERS

Adverse Slopes

When working with the flailhead high and reach fully in it is possible for the main arm balance to go over centre and take the weight off the lift ram. A restrictor in the gland circuit of the lift ram will prevent sudden unpredictable movements if this should occur - *for reasons of safety this restrictor should not be removed.*

DANGER!



NEVER REMOVE THE RESTRICTOR FROM THE LIFT RAM GLAND CIRCUIT.

Never work the machine on adverse slopes with the arms positioned such that the tractor is unbalanced ►

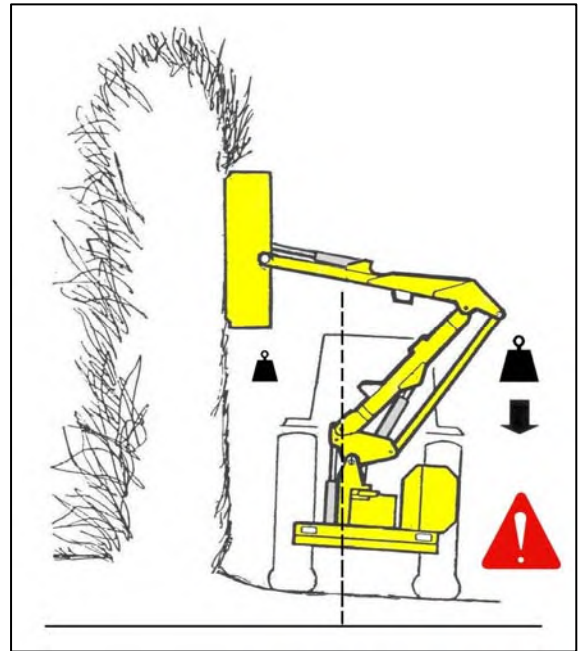

DANGER!



NEVER CUT TO THE BLIND SIDE OF A HEDGE
- it is impossible to see any potential hazards or dangers and the position of the flail head would allow debris to be propelled through the hedge towards the tractor and operator.

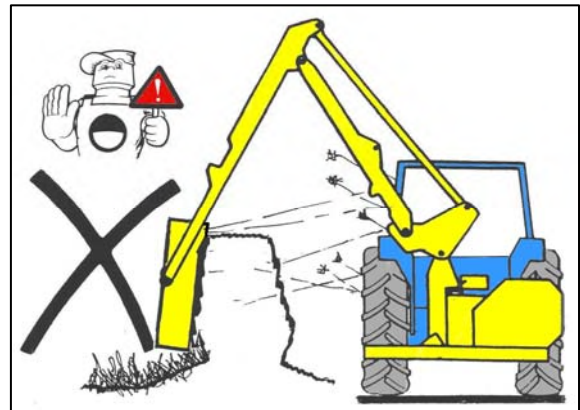

DANGER!



NEVER OPERATE THE MACHINE WITH THE FLAIL HEAD ROLLER REMOVED

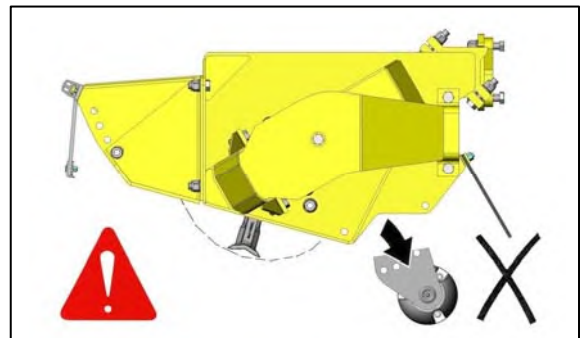

DANGER!



WHEN GRASS MOWING THE ROTOR MUST ALWAYS CUT IN THE UPHILL DIRECTION WITH FRONT HOOD FITTED AND THE ROLLER POSITIONED BELOW THE CUTTING HEIGHT OF THE FLAILS

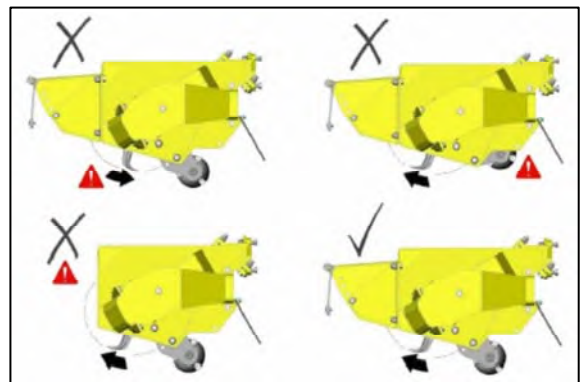

OVERHEAD POWER LINES (OHPLs)

It cannot be stressed enough the dangers involved when working in the vicinity of Overhead Power Lines (OHPLs). Some of our machines are capable of reach in excess of 8 metres (26'); they have the potential to well exceed, by possibly 3 metres (9' 9"), the lowest legal minimum height of 5.2 metres from the ground for 11,000 and 33,000 volt power lines.

Remember electrocution can occur without actually coming into contact with a power line as electricity can 'flashover' when machinery gets close to it.



WARNING: All operators must read the following information and be aware of the risks and dangers involved when working in the vicinity of Overhead Power Lines (OHPLs).

Wherever possible the safest option is always to avoid working in areas close to OHPLs. Where unavoidable, all operators must perform a risk assessment and implement a safe procedure and system of work – see *following page for details*. All operators should perform a risk assessment before operating the machine within 10m horizontal distance of any OHPLs.

Minimum Heights for Overhead Power Lines

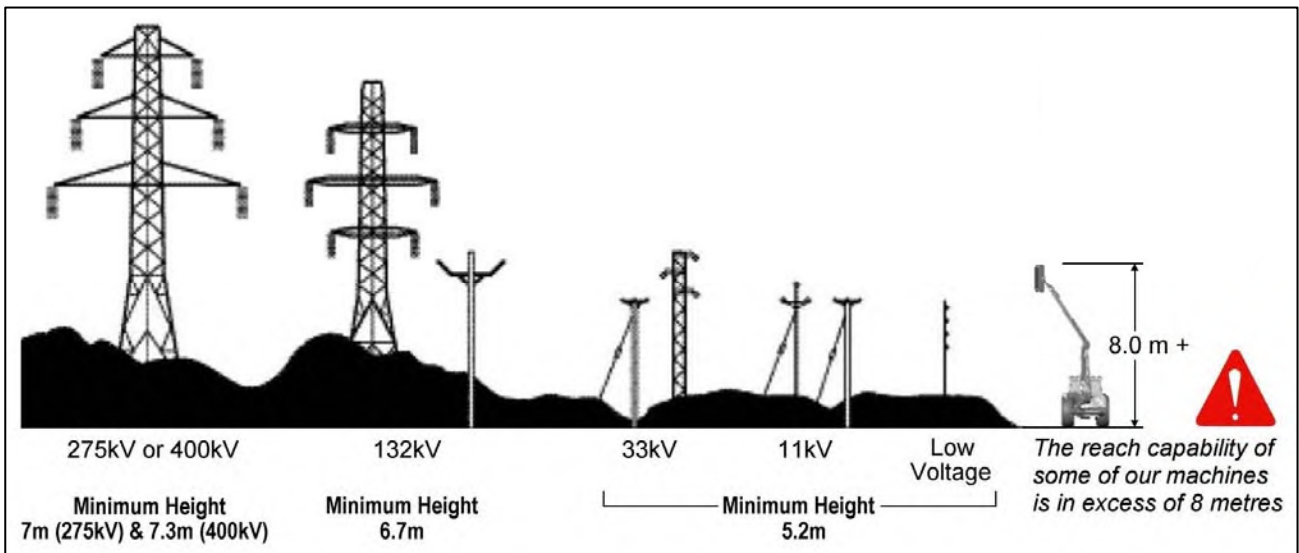

Absolute Minimum Exclusion Zones for Specific Overhead Power Lines

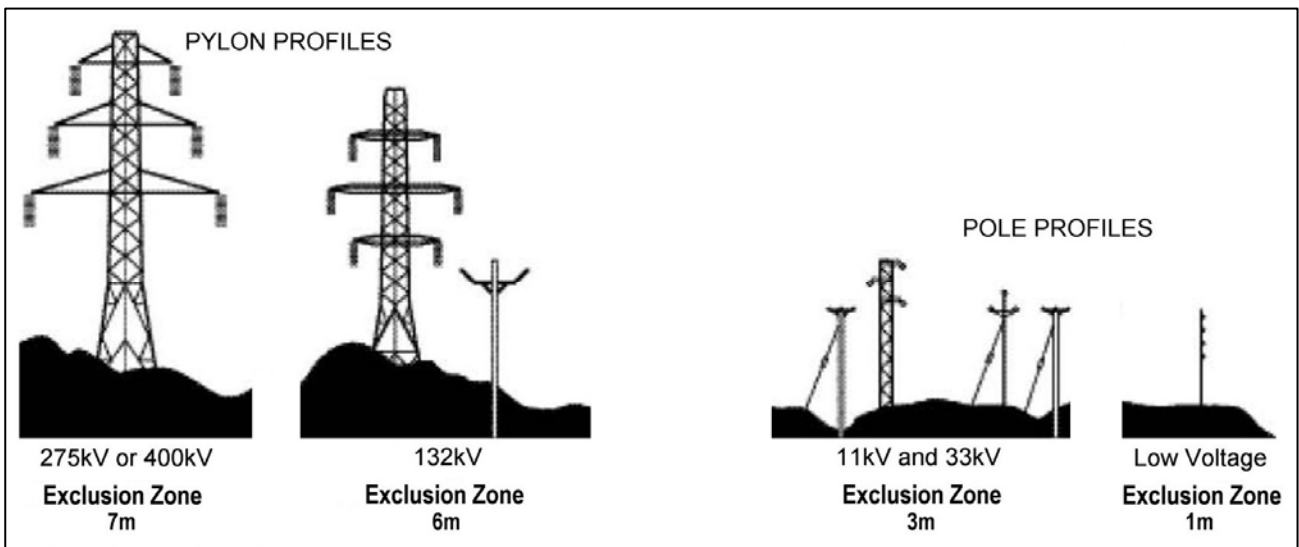

Definitions of Exclusion Zones

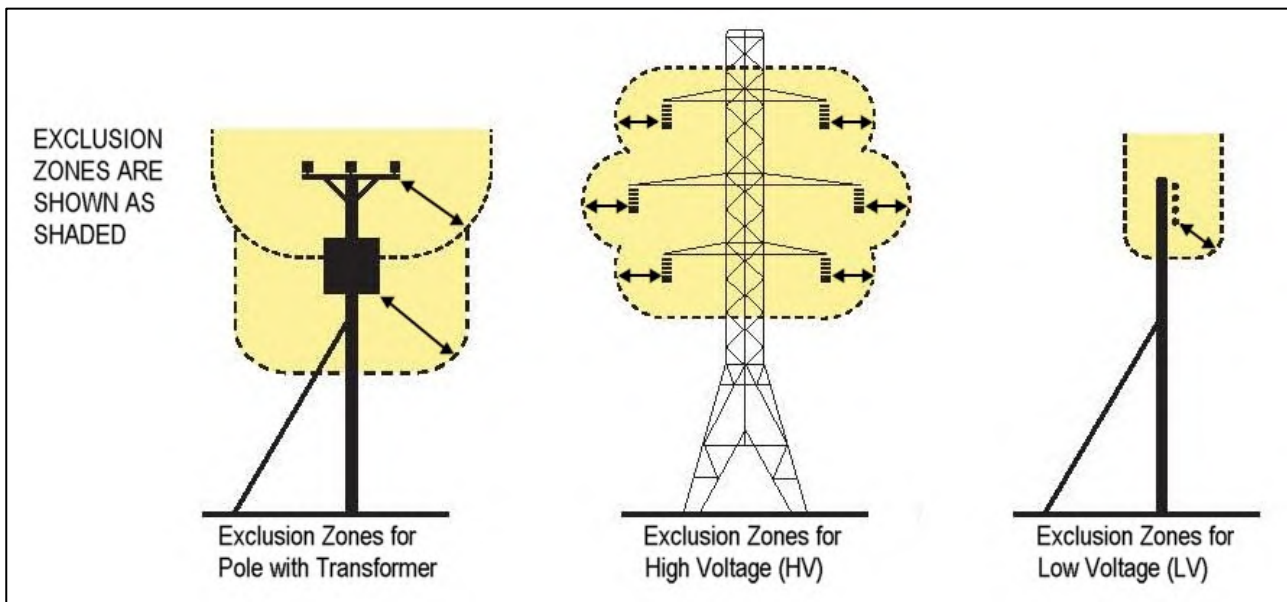

Risk Assessment

Before starting to work near OHPLs you should always assess the risks. The following points should be observed;

- ▲ **Know the risks** of contacting OHPLs and the risk of flashover.
- ▲ **Find out** the maximum height and maximum vertical reach of your machine.
- ▲ **Find out** the location and route of all Power Lines within the work area.
- ▲ **Find out** the operating voltage of all Power Lines within the work area.
- ▲ **Contact** the local Distribution Network Operator (DNO) who will be able to advise you on the operating voltage, safe minimum clearance distance for working, and additional precautions required.
- ▲ **Never** attempt to operate the machine in exclusion zones.
- ▲ **Always** work with extreme caution and plan your work ahead to avoid high risk areas.
- ▲ **If doubt exists** do not work in the area – never risk the safety of yourself or others.

Emergency Action for Accidents Involving Electricity

- Never touch an overhead line - even if it has been brought down by machinery, or has fallen. Never assume lines are dead.
- When a machine is in contact with an overhead line, electrocution is possible if anyone touches both the machine and the ground. Stay in the machine and lower any raised parts in contact or drive the machine out of the lines if you can.
- If you need to get out to summon help or because of fire, jump out as far as you can without touching any wires or the machine - keep upright and away.
- Get the electricity company to disconnect the supply. Even if the line appears dead, do not touch it - automatic switching may reconnect the power.

Further information and leaflets on this and other agricultural safety subjects are available on the 'Health & Safety Executive' website at the following address: www.hse.gov.uk/pubns/agindex.htm

FLAILS IDENTIFICATION

Grass Flails

Designed specifically for general mowing activities – low power usage, ideal for cutting materials of low density.

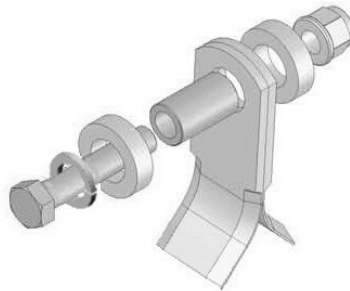

F10 Grass Flail
(Part No. 7190315)

Universal Boot Flails

Designed for general purpose work - suitable for mowing duties and the cutting of hedges with up to 2 years growth.

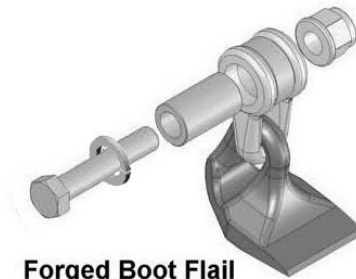

Forged Boot Flail
(Part No. 7190462)

Hedge Flails

Double edged flail designed specifically for heavy duty hedge cutting - capable of cutting materials up to 75/80mm diameter. Can be used for mowing work where they produce a good finish but will require considerably more power and reduced forward speed when used for this purpose.

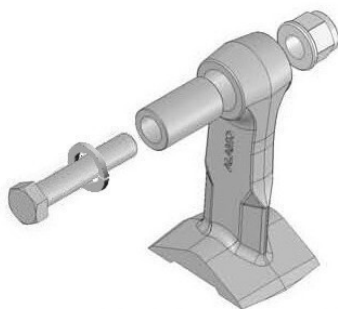

F10 D.E. Forged Flail
(Part No. 41391.02)

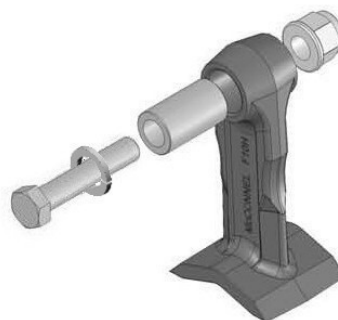

F10 D.E. Cast Flail
(Part No. 7314366D)

NOTE: Cast flails are more suitable where the work is predominantly hedge cutting as they maintain a sharper cutting edge – forged versions possess a higher degree of durability and are therefore more suitable where the primary function is mowing work and there is increased risk of hitting foreign objects.

Hedge Flails

Double edged flail designed specifically for heavy duty hedge cutting, capable of cutting materials up to 75/80mm diameter. Can be used for mowing work where they produce a good finish but will require considerably more power when used for this purpose. The flails are fitted with rubber stops for both shaft protection and noise reduction purposes.

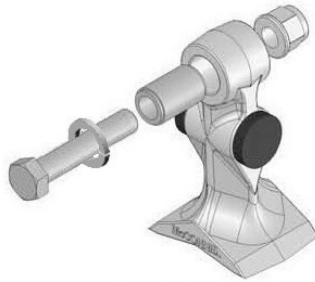

F16 D.E. Cast Flail
(Part No. 21904.02)

Competition Flails

Single edged flail designed specifically for heavy duty hedge and grass cutting, capable of dealing with materials up to 75/80mm diameter. When used for mowing work they produce a better finish and performance than double edged flails requiring less power and increased forward speed.

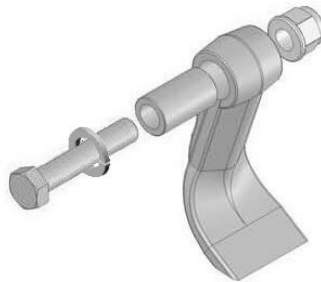

F10 S.E. Cast Flail
(Part No. 7390276)

Omega Flails

Double edged flail for use on 'Omega' rotors only - designed specifically for heavy duty hedge cutting where they are capable of cutting materials up to 75/80mm diameter. Unique rotor design allows the flail to rotate 360° on its pivot protecting the flail on impact with immovable objects. Not suitable for mowing work.

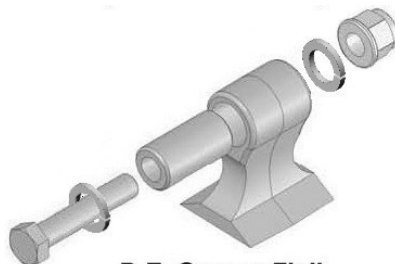

D.E. Omega Flail
(Part No. 7190464)

GENERAL MAINTENANCE

Machine Lubrication

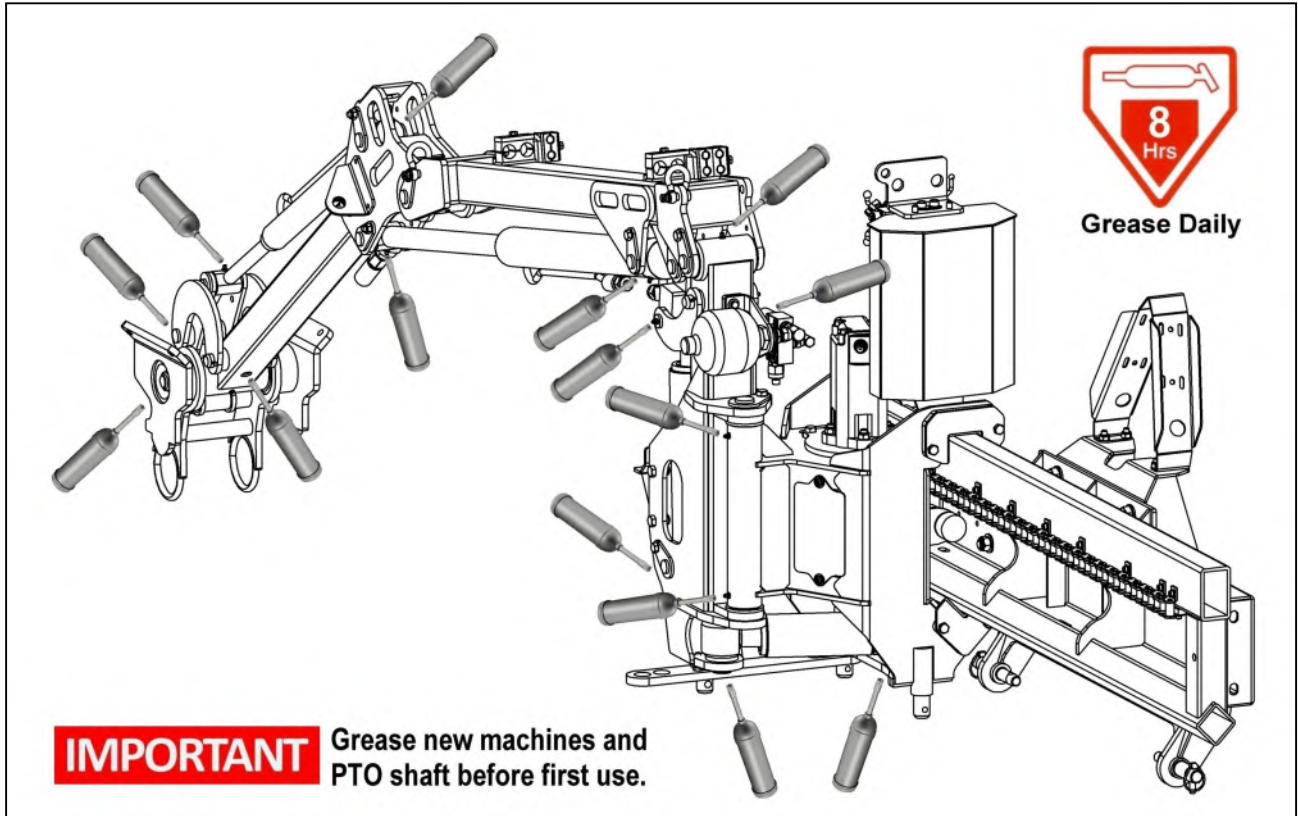

The illustration above indicates the general locations of grease points; all grease points should be lubricated on a daily basis before work and prior to storage of the machine.

SERVICE SCHEDULE

Every Day	
<ul style="list-style-type: none">• Grease machine fully prior to work (and prior to storage). NOTE: New machines must be fully greased before initial use.• Check for broken or damaged flails.• Check tightness of flail nuts and bolts.• Visually check for oil leaks and damaged hoses.• Check all guards and safety shields are correctly fitted and undamaged.• Ensure all lights are working and clean.• Check oil level.• Clean cooler matrix; in dusty conditions more frequent cleaning is required.	
After initial 50-hours	
<ul style="list-style-type: none">• Change gearbox oil.	
Every 25-hours	
<ul style="list-style-type: none">• Grease PTO Shaft universal joints and tubes.	
Every Week	
<ul style="list-style-type: none">• Check tightness of all nuts and bolts.• Check gearbox oil level.• Check for wear on telescopic arm pads – <i>where applicable</i>.	
Every 100-hours	
<ul style="list-style-type: none">• Grease PTO shaft shield lubrication points.• Check bushes for wear; <i>wherever possible, remove end caps to allow inspection</i>.	
Every 500-hours	
<ul style="list-style-type: none">• Change return line filter element (<i>500-hours or annually, whichever occurs first</i>).• Change tank breather.• Change gearbox oil.• Check condition of hydraulic oil and change if required; <i>when changing the oil, new return line filter and suction strainer elements should be fitted and the return line filter changed again after 100 hours of work</i>.	
Annually	
<ul style="list-style-type: none">• Change tank breather.	

Cooler Matrix

To ensure maximum cooler efficiency, the cooler matrix must be kept as clean as possible to allow free air flow through the unit; this is especially important in dry hot arduous conditions where the matrix can rapidly become blocked by dust causing overheating. Cooler units are best cleaned using a high-pressure air line that will clear blocked areas without risking damage to the matrix.

SIDE SHIFT CARRIAGE

The motorised side shift carriage is equipped with replaceable wear pads; these should be inspected on a regular basis and the gap between the lower carriage rail and the lower wear pads checked with a feeler gauge. The correct gap between the carriage rail and the wear pads is 2mm. Fit shims (*Part No. 7136059*) behind the wear pad if required to ensure the gap remains correct.

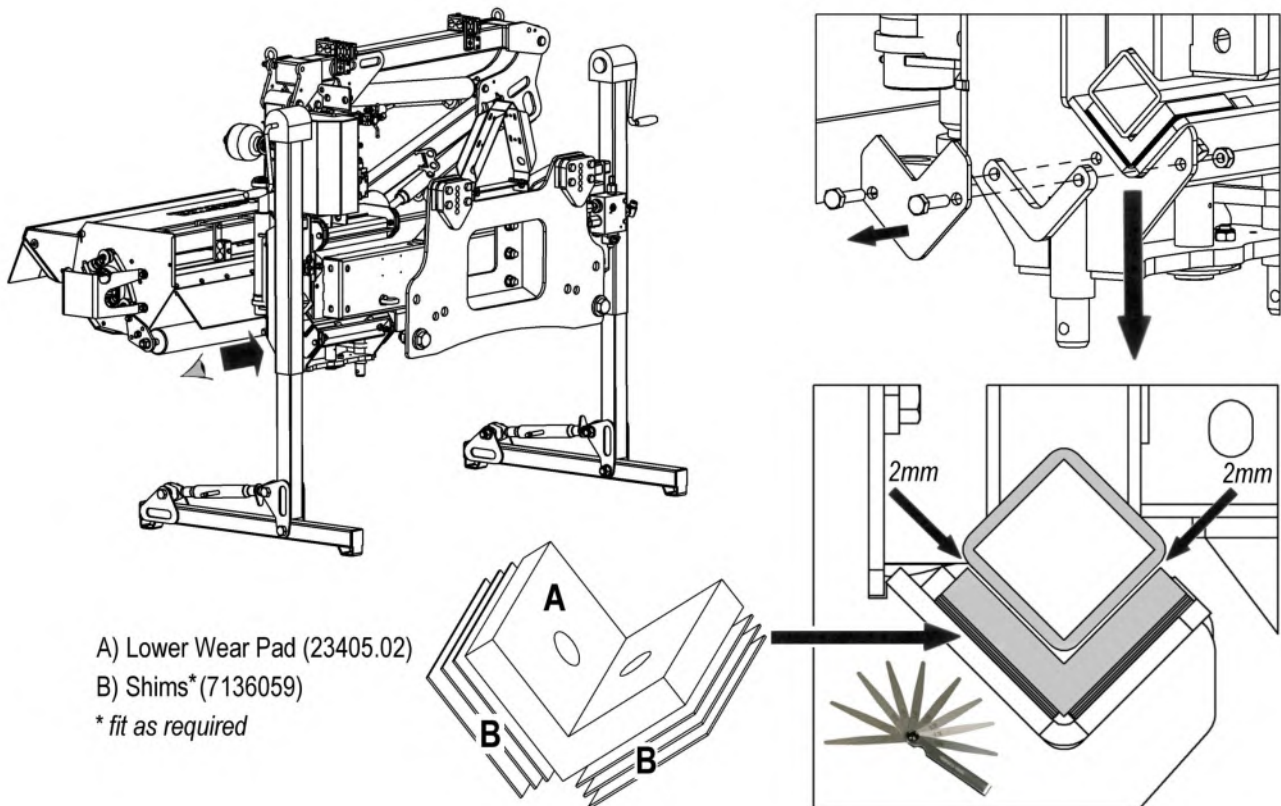

FLAIL HEAD

Frequently inspect the rotor assembly for damaged or missing flails. Bolts and nuts securing the flails to the rotor should be regularly checked and kept tight. The correct torque setting for these locknuts is 135Nm (100 lbf/ft.). Use only the correct flail bolt and locking nut. Check the flail pivot bushes for possible damage or wear - they do not require oil.

Do not attempt to run the rotor with flails missing. Imbalance will cause severe vibration and can rapidly damage the rotor shaft bearings. As an emergency measure if a flail is broken off or lost, remove another on the opposite side of the rotor to retain balance. Always replace flails in opposite pairs and never match up a new flail with a re-sharpened one, which will of course be lighter.

Blunt flails absorb a lot of power and leave an untidy finish to the work. They should be sharpened on a grindstone or with a portable grinder periodically.

WARNING!
Wear protective gear when sharpening flails.

Ensure that the bearing housings and hydraulic mounting nuts and bolts are kept tight. They should be checked during servicing.

For further information relating to flail head maintenance please refer to the operation and parts manual that accompanied the specific flail head.

HYDRAULIC HOSES

The condition of all hoses should be carefully checked during routine service of the machine. Hoses that have been chaffed or damaged on their outer casing should be securely wrapped with waterproof adhesive tape to stop the metal braid from rusting. Hoses that have suffered damage to the metal braid should be changed at the earliest opportunity.

Hose Replacement

- Replace one hose at a time to avoid the risk of wrong connections.
- When the hose is screwed to an additional fitting or union, use a second spanner on the union to avoid breaking both seals.
- Do not use jointing compound on the threads.
- Avoid twisting the hose. Adjust the hose line to ensure freedom from rubbing or trapping before tightening hose end connections.

Before changing hoses study the installation these are carefully calculated to prevent hose damage during operation. Always replace hoses in exactly the same manner. This is especially important for the flail hoses where they must be crossed, upper to lower, at the dipper and head pivots.

All BSP Hydraulic Hoses fitted to McConnel Power Arms have 'Soft Seal' connections on the flail circuit and ram circuit.

Recommended torque settings for nut security:

	Nut Size	Nm	Ft-lbs	O-Ring
	1/4" BSP	24	18	P/No. 10.000.01
	3/8" BSP	33	24	P/No. 10.000.02
	1/2" BSP	44	35	P/No. 10.000.03
	5/8" BSP	58	43	P/No. 10.000.04
	3/4" BSP	84	62	P/No. 10.000.05
1" BSP	115	85	P/No. 10.000.06	

Recommended torque settings for BSP hose unions fitted in conjunction with bonded seals:

	Union Size	Nm	Ft-lbs	Bonded Seal
	1/4" BSP	34	25	P/No. 8650102
	3/8" BSP	75	55	P/No. 8650103
	1/2" BSP	102	75	P/No. 8650104
	5/8" BSP	122	90	P/No. 8650105
	3/4" BSP	183	135	P/No. 8650106
1" BSP	203	150	P/No. 8650108	

Safety Note

The soft seal hose connections are capable of holding pressure when the nut is only finger tight, it is therefore recommended when dismantling that the hose be manually flexed with the retaining nut slackened to relieve any residual pressure prior to complete disassembly.

TROUBLESHOOTING CHART

The chart below lists possible causes and solutions to problems that may be encountered.

PROBLEM	POSSIBLE CAUSE	SOLUTION
Gearbox overheating	Oil level incorrect	Check oil level
	Oil grade incorrect	Check oil grade
	Implement overloaded	Reduce forward speed
	Wrong PTO speed	Ensure tractor PTO speed matches implement
Excessive belt wear	Belt and pulley condition	Replace if necessary
	Pulley alignment	Check alignment
	Incorrect belt tension	Tension belts to spec
	Overloading of implement	Reduce forward speed or increase cut height
PTO wear / UJ failure	Working angle too great	Reduce mis-alignment of drive stub shafts
	Shaft length incorrect; bottoming out	Resize PTO shaft as recommended
	Lack of maintenance	Grease PTO shaft as recommended
Cut Quality	Flails worn or damaged	Replace worn/damaged flails
	Rotor speed / direction	Check rotor direction/tractor PTO speed
	Cutting conditions	Work in suitable cutting conditions
Rotor bearing failure	Rotor out of balance	Refer to rotor vibration below
	Wire / string in bearing	Remove wire / string
	Lack of maintenance	Grease bearings to schedule
	Moisture in bearing(s)	Grease bearing(s) to expel moisture
Rotor vibration	Flails broken or missing	Replace flails
	Bearings worn or damaged	Replace bearings
	Rotor unbalanced / bent	Re-balance / replace rotor
	Debris build up	Remove debris
	Incorrect speed	Check rotor RPM
Oil tank overheating	Oil level incorrect	Fill tank to correct level
	Oil grade incorrect	Drain and refill tank with correct grade oil
	PTO speed too fast	Match the tractor's PTO speed to machine
	Ambient temperature too high	Reduce work rate / install oil cooler
	Machine overloaded	Reduce forward speed or increase cut height
Frequent Break-back	Machine overloaded	Reduce forward speed or increase cut height
	Working on excessive incline	Disable auto-reset
	Machine weight sat on rear roller	Raise head or operate with head float
	Machine not set vertical	Adjust top link
	Internal valve leakage	Contact local dealer or McConnel Service
Hydraulics not responding	Oil level low	Fill oil to correct level
	Oil pump suction filter blocked	Replace filter element
	Oil leak in pressure line	Check machine for hydraulic leaks
	Drive line broken	Check pump is rotating
Irregular arm movement	Spool contacting with housing	Check spool moves freely
	Broken spring in spool valve	Check spring in spool valve
	Ram seal failure	Replace ram seals
Electric valve unresponsive	Faulty wiring	Check wiring and switches
	Dirt in valve	Check for ingress of dirt
	Sticking valve	Replace the valve
	Insufficient voltage	Ensure power is sourced direct from battery



McConnel Limited, Temeside Works, Ludlow, Shropshire SY8 1JL. England.
Telephone: 01584 873131. Facsimile: 01584 876463. www.mcconnel.com