

Publikation 688
Oktober 2011
Art. No. 22674.88
Überarbeitet: 15.07.15

REVOLUTION

PROPORTIONALE STEUERUNGEN



Bedienungsanleitung

Für Gebrauch in Kombination mit Maschinen ausgestattet mit diese Steuerung



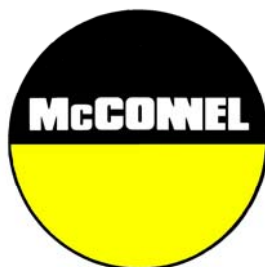

Für Sicherheit und Leistung...

LESEN SIE IMMER ZUERST DIESES BUCH

McCONEL LIMITED

Temeside Works

Ludlow

Shropshire

England

Telephone: 01584 873131

www.mcconnel.com

INDEX

Kennzeichnung der Steuerung	1
Software Version und Menüs	2
Leistung Ein/Aus	3
Joystick Betrieb und Rückstellungs-Schalter-Funktionen	4
Rotor Ein/Aus	5
Auftragstunden Zurückstellen	6
Arm Schwenken Betrieb & Schwenk/Tele Wechsel Funktion	7
Anfahrautomatik	8
Schwimmstellung Mährotor	8
Schwimmstellung/EDS	9
Funktionwechsel D1 / D2 / D3	10
Bildschirm Navigation - Menu Fenster und Arbeitsfenster	11
Bildschirm Navigation - Joystick Status Fenster	12
Spracheinstellung	13
Menü-Zugang und Einstellungen	14
Auslage Wechsel	15
Einstellung Auslagebegrenzung	16
Entfernen Auslagebegrenzung	17
Joystick Einstellungen	18
Joystick Probe/Kalibrierung	19
Ventil-Einstellungen und Ventil 2-Einstellungen	23
Ventil Bank Featureauswahl	26
Warntöne Ein/Aus	27
Filter Gebrauchzeiten Warnung (Anfangsfilter)	28
Filter Gebrauchzeiten Warnung (Wiedereinbau-Filter)	29
Bestandteile Angeschlossen Warnung	30
Über Drehzahl Warnung Fenster	30
Überbelastung Warnung Fenster	31
Sprachübersetzungen	32

KENNZEICHNUNG DER STEUERUNG

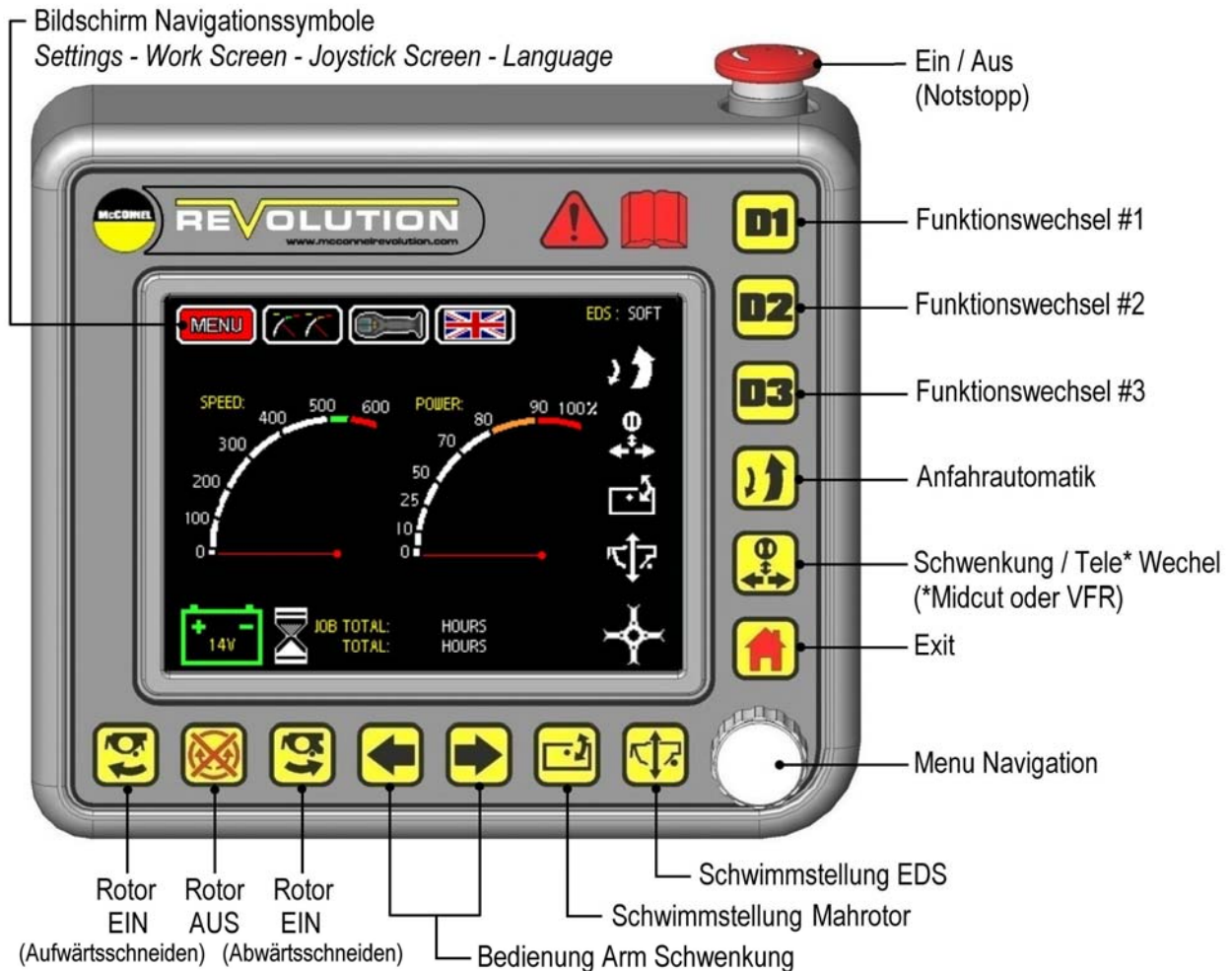
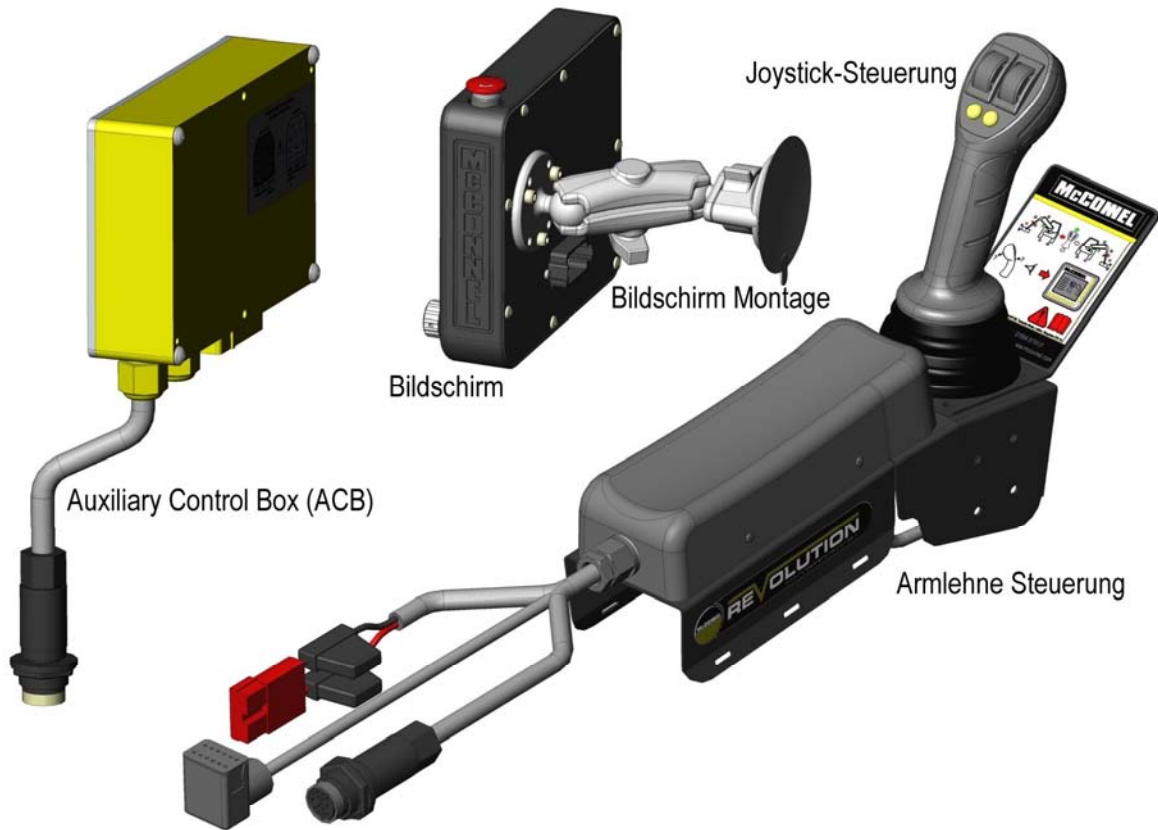

i Tele/VFR Maschinen ist standardmäßig Slew Swap mit der VFR-Funktion;
i Tele-Funktion, um D1 Umsteller Steuerung konfiguriert ist.

SOFTWARE VERSION UND MENÜ

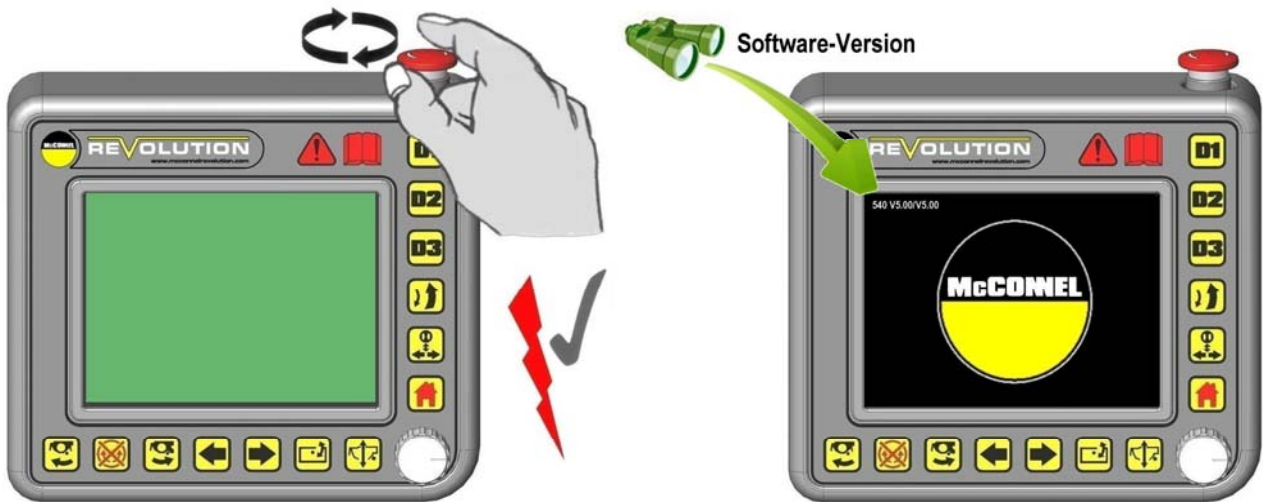

Software-Version v5.07



Betreiber



- △ MENU : EXIT
- ▼ ● EDS PID
- ▼ ● ZAPFWELLE
- ▼ ▶ TEST/KALIBRIERUNG
- ▼ ▶ JOYSTICKEINSTELLUNGEN
- ▼ ▶ VENTILE
- ▼ ● EINSTELLUNGEN
- ▼ ▶ AUSLAGE
- ▼ ▶ AUSLAGESTOPP
- ▼ ▶ SCHWENKBEGRENZUNG
- ▼ ● D1 AUSWAHL
- ▼ um
- ▼ ● D5 AUSWAHL
- ▼ ▶ WARNTON
- ▼ ▶ FILTERLAUFZEIT
- ▼ ● FILTERREPORT
- ▼ ▶ INFO
- ▼ ● PASSWORT

Händler / Fabrik



- △ MENU : EXIT
- ▼ ▶ EDS PID
- ▼ ▶ ZAPFWELLE
- ▼ ▶ TEST/KALIBRIERUNG
- ▼ ▶ JOYSTICKEINSTELLUNGEN
- ▼ ▶ VENTILE
- ▼ ▶ EINSTELLUNGEN
- ▼ ▶ AUSLAGE
- ▼ ▶ AUSLAGESTOPP
- ▼ ▶ SCHWENKBEGRENZUNG
- ▼ ▶ D1 AUSWAHL
- ▼ um
- ▼ ▶ D5 AUSWAHL
- ▼ ▶ WARNTON
- ▼ ▶ FILTERLAUFZEIT
- ▼ ▶ FILTERREPORT
- ▼ ▶ INFO
- ▼ ▶ PASSWORT

Software-Version v5.08



Betreiber



- △ MENU : EXIT
- ▼ ● EDS PID
- ▼ ● ZAPFWELLE
- ▼ ▶ TEST/KALIBRIERUNG
- ▼ ▶ JOYSTICKEINSTELLUNGEN
- ▼ ▶ VENTILE
- ▼ ▶ VENTILE 2
- ▼ ● EINSTELLUNGEN
- ▼ ▶ AUSLAGE
- ▼ ▶ AUSLAGESTOPP
- ▼ ▶ SCHWENKBEGRENZUNG
- ▼ ● D1 AUSWAHL
- ▼ um
- ▼ ● D5 AUSWAHL
- ▼ ▶ WARNTON
- ▼ ▶ FILTERLAUFZEIT
- ▼ ● FILTERREPORT
- ▼ ▶ INFO
- ▼ ● PASSWORT
- ▼ ● PASSWORT

Händler / Fabrik



- △ MENU : EXIT
- ▼ ▶ EDS PID
- ▼ ▶ ZAPFWELLE
- ▼ ▶ TEST/KALIBRIERUNG
- ▼ ▶ JOYSTICKEINSTELLUNGEN
- ▼ ▶ VENTILE
- ▼ ▶ VENTILE 2
- ▼ ▶ EINSTELLUNGEN
- ▼ ▶ AUSLAGE
- ▼ ▶ AUSLAGESTOPP
- ▼ ▶ SCHWENKBEGRENZUNG
- ▼ ▶ D1 AUSWAHL
- ▼ um
- ▼ ▶ D5 AUSWAHL
- ▼ ▶ WARNTON
- ▼ ▶ FILTERLAUFZEIT
- ▼ ▶ FILTERREPORT
- ▼ ▶ INFO
- ▼ ▶ PASSWORT
- ▼ ▶ PASSWORT

LEISTUNG EIN / AUS

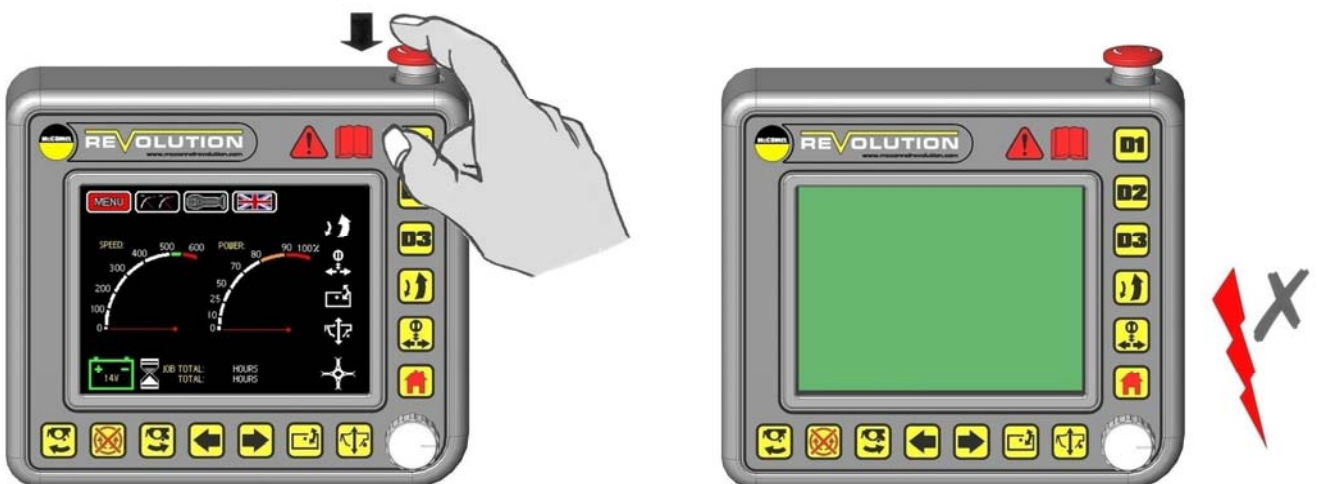

JOYSTICK BETRIEB UND RÜCKSTELLUNGS-SCHALTER-FUNKTIONEN

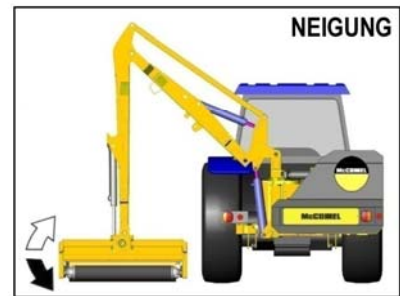
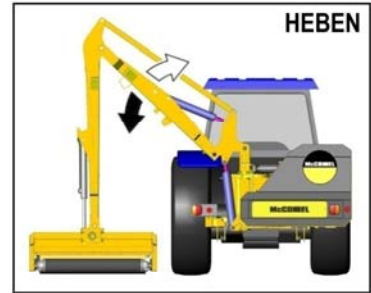
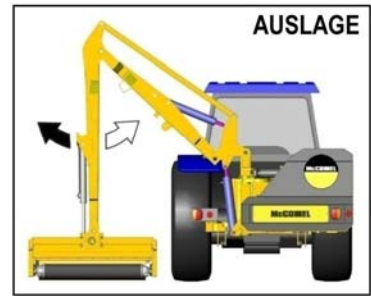

Standard

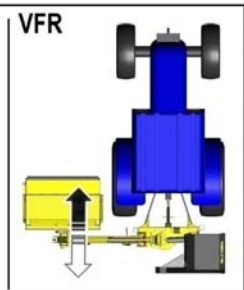
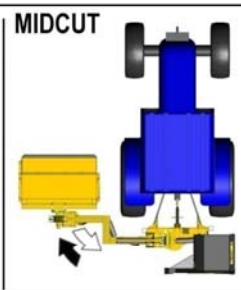
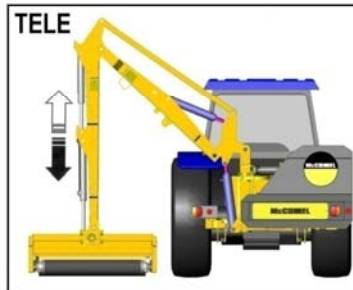

Inversions Bedienung

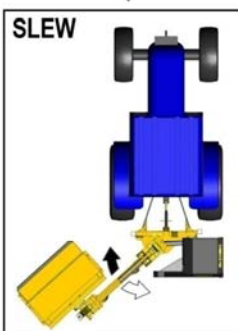

Inversions Bedienung

Standard

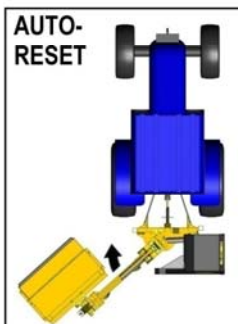
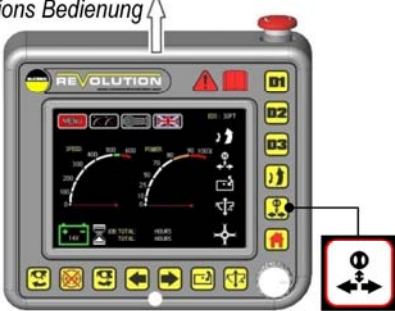

ROTOR EIN / AUS

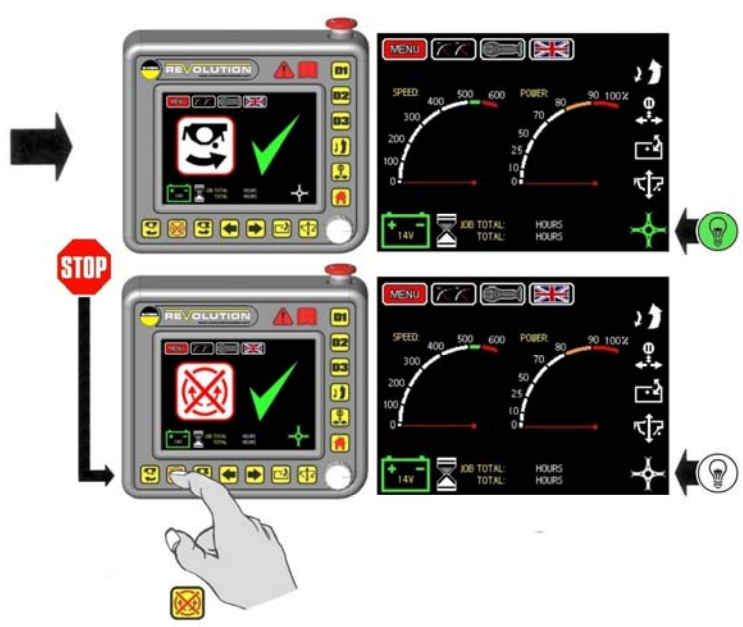
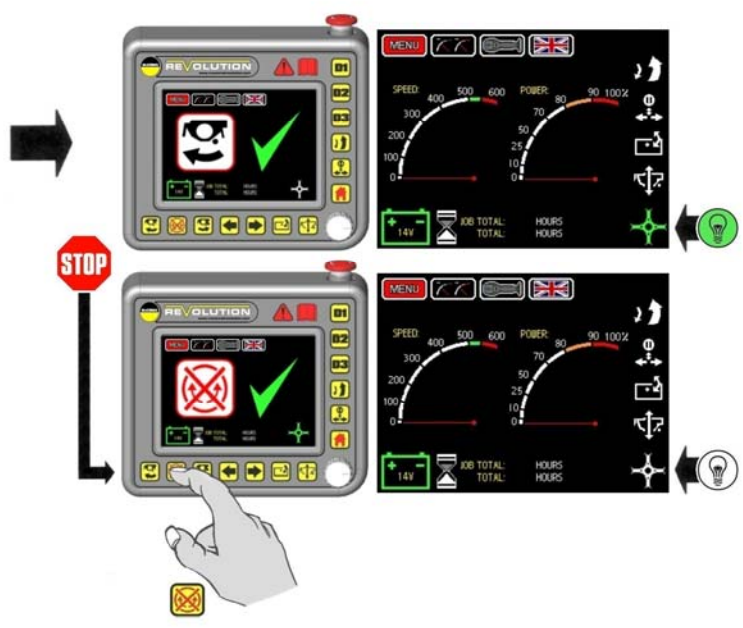

AUFTRAGSTUNDEN ZURÜCKSTELLEN

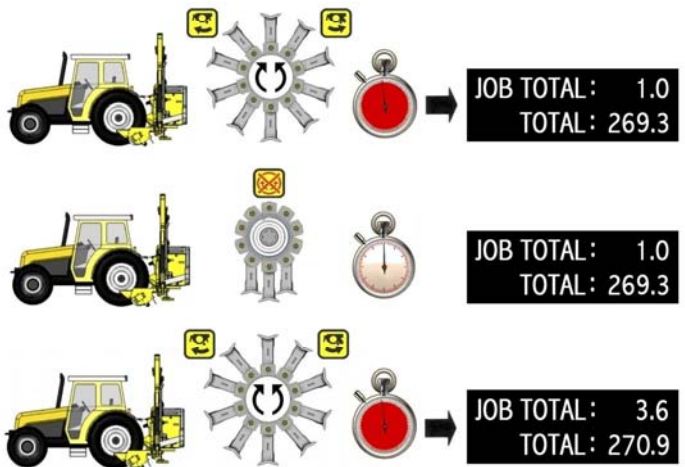
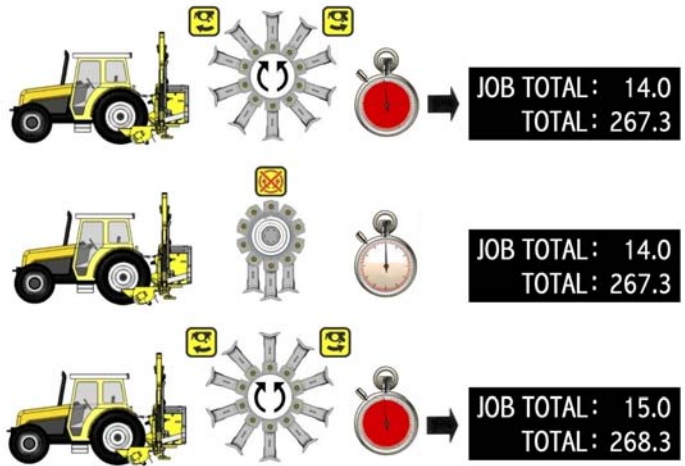

ARM SCHWENKEN BETRIEB & SCHWENK/TELE WECHSEL FUNKTION

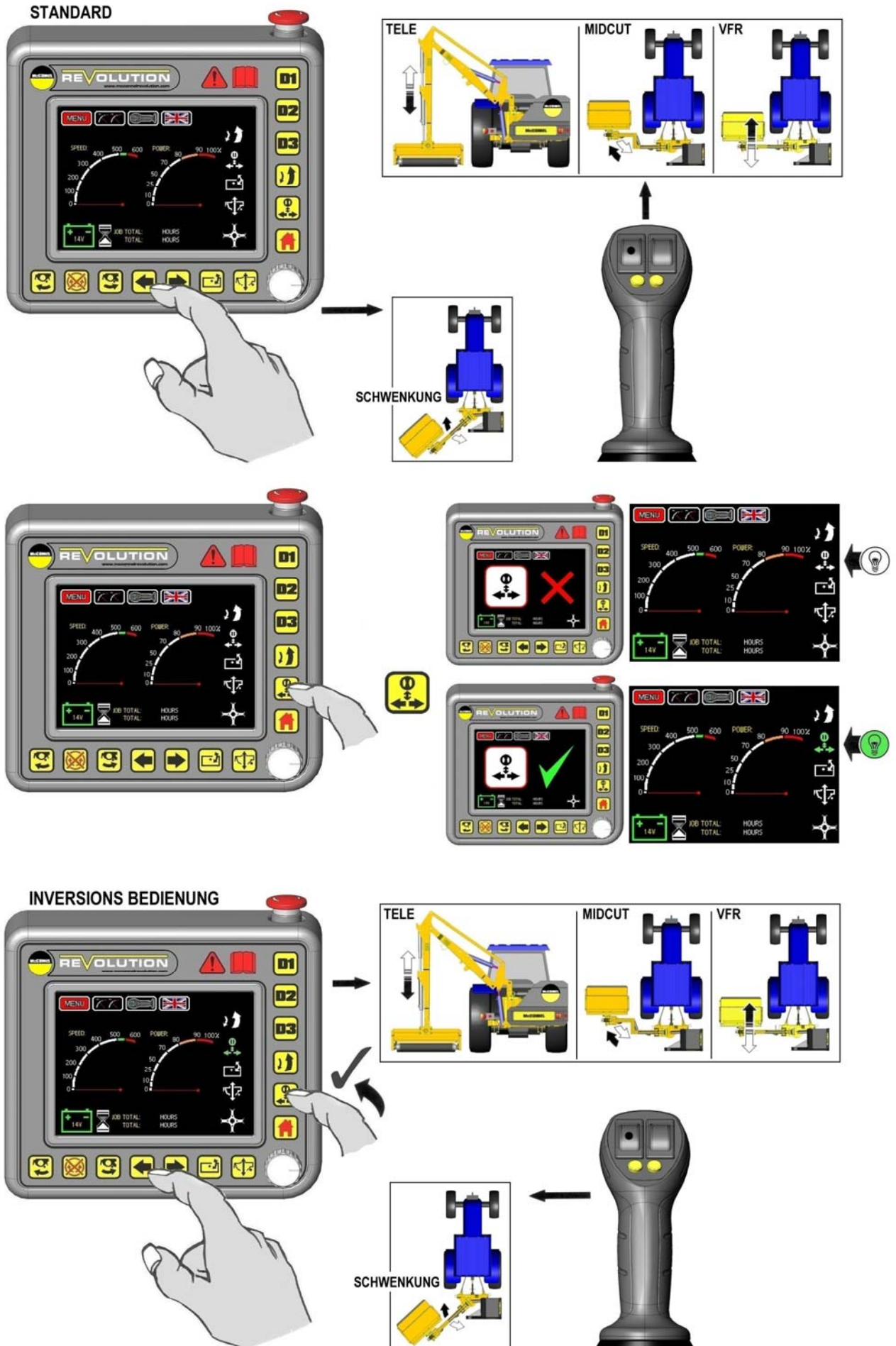

ANFAHRAUTOMATIK

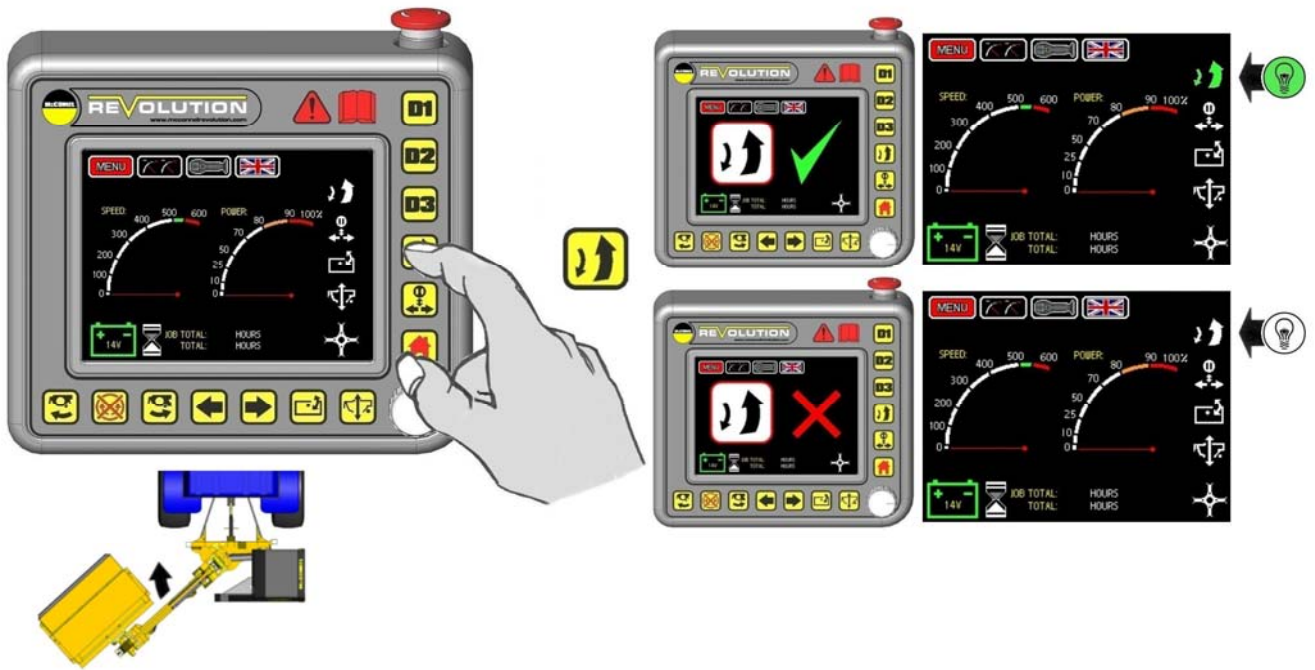

SCHWIMMSTELLUNG MÄHROTOR

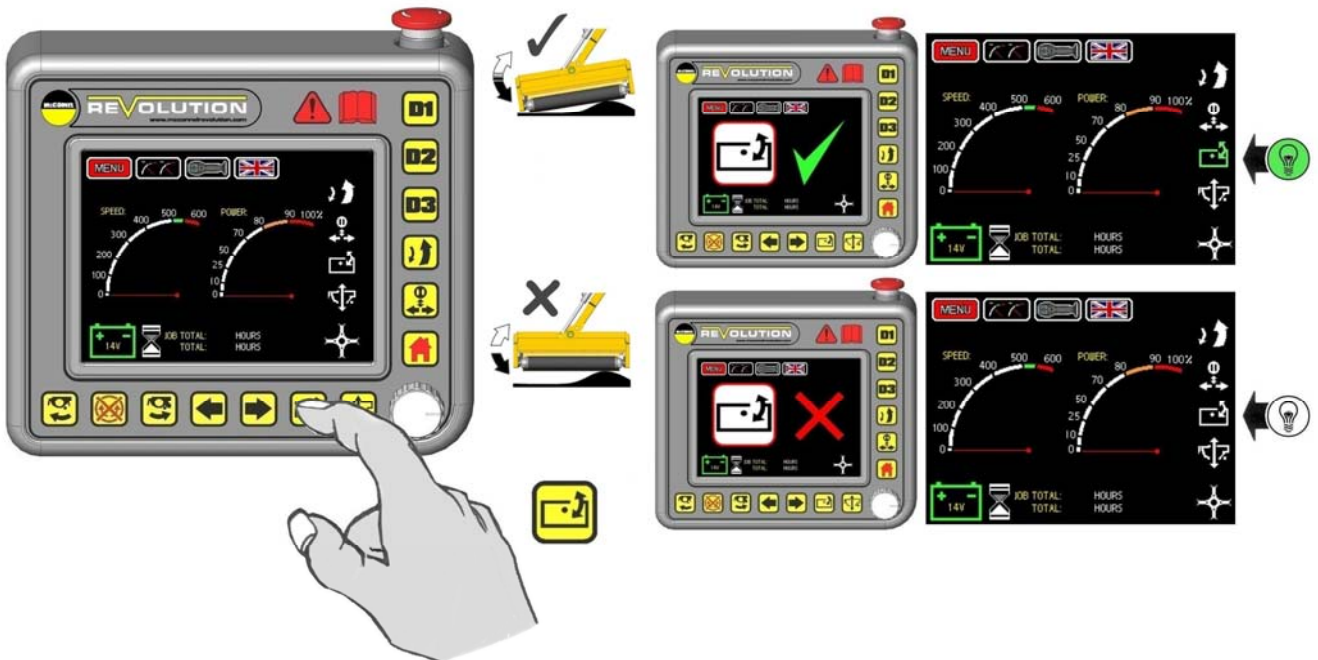

SCHWIMMSTELLUNG / EDS

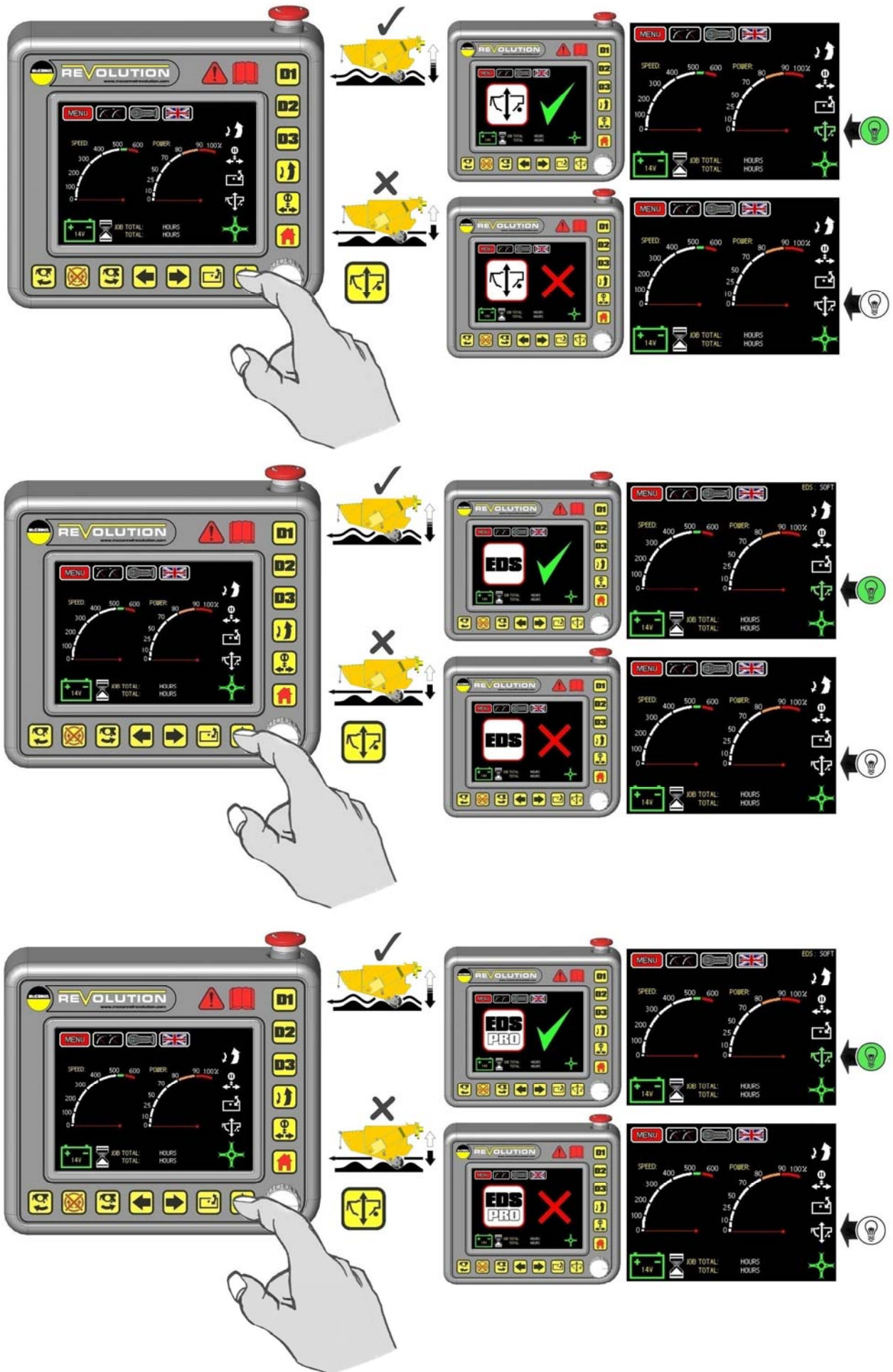

FUNKTIONSWECHSEL D1 / D2 / D3

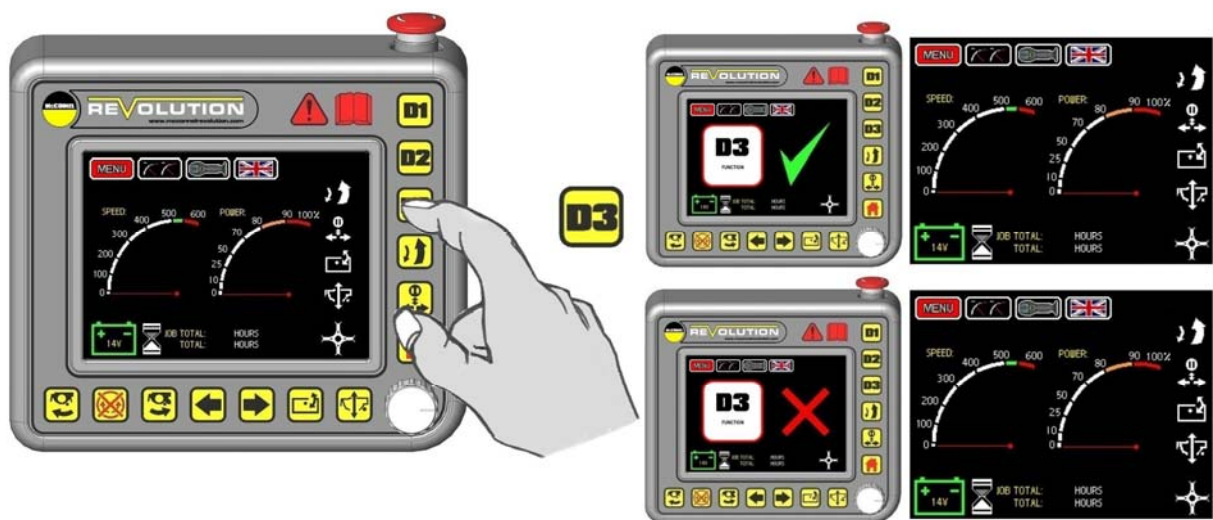
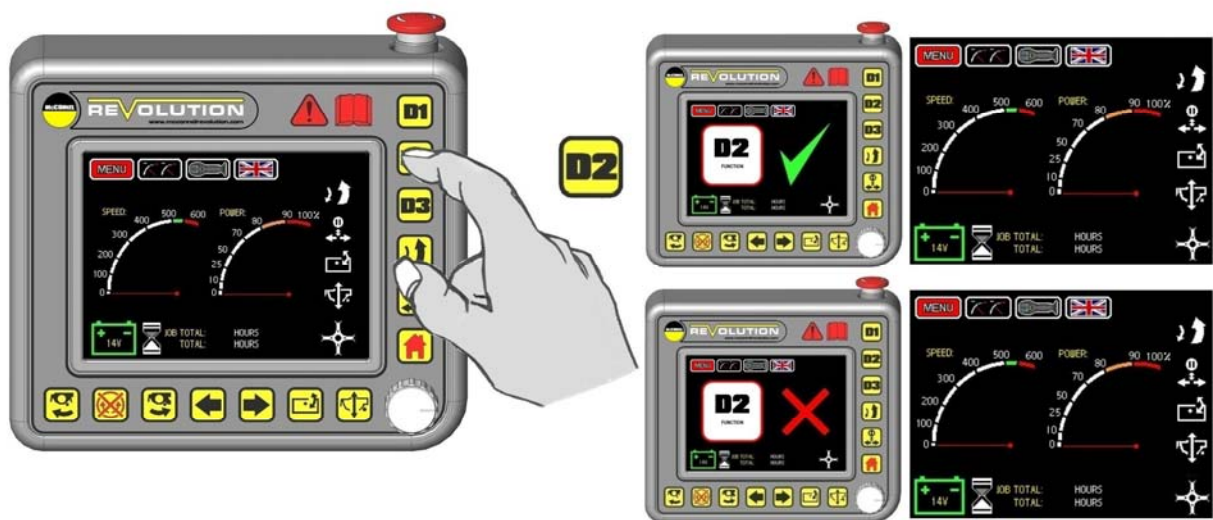
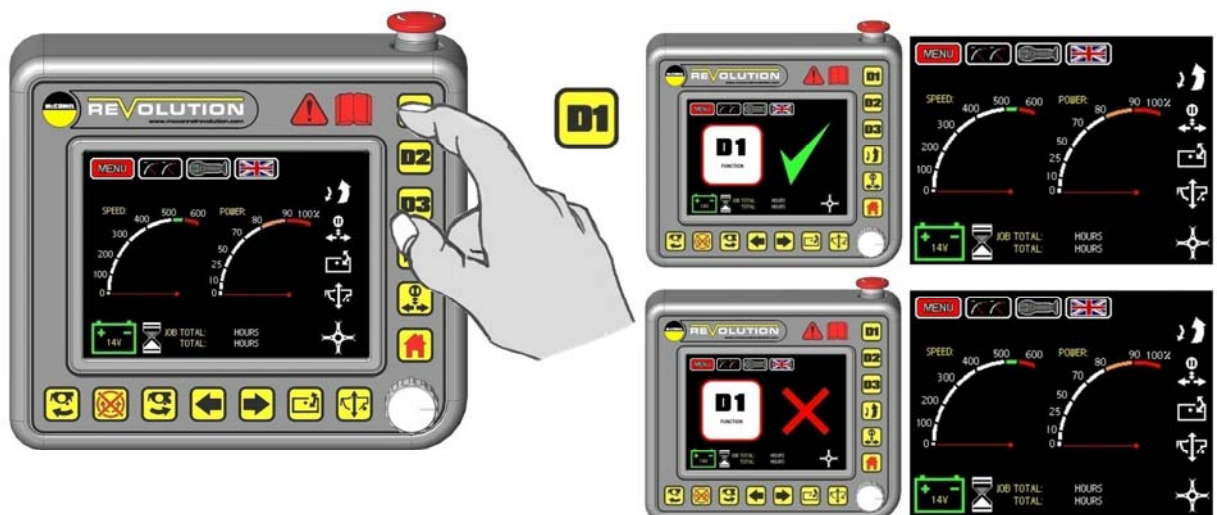

BILDSCHIRM NAVIGATION – Menu Fenster und Arbeitsfenster

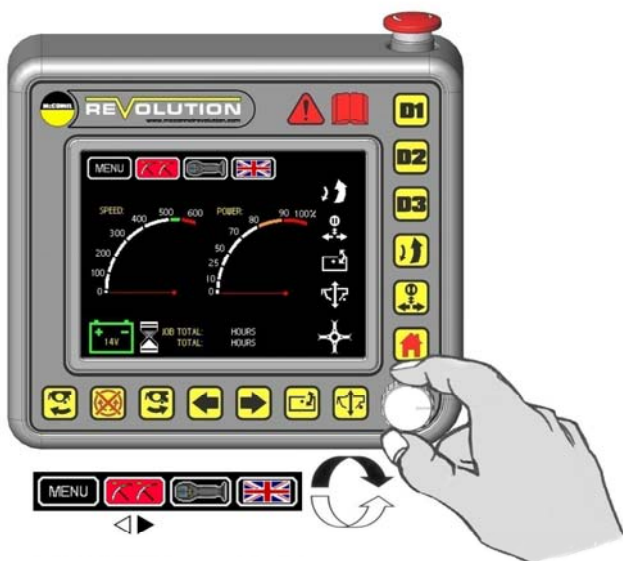
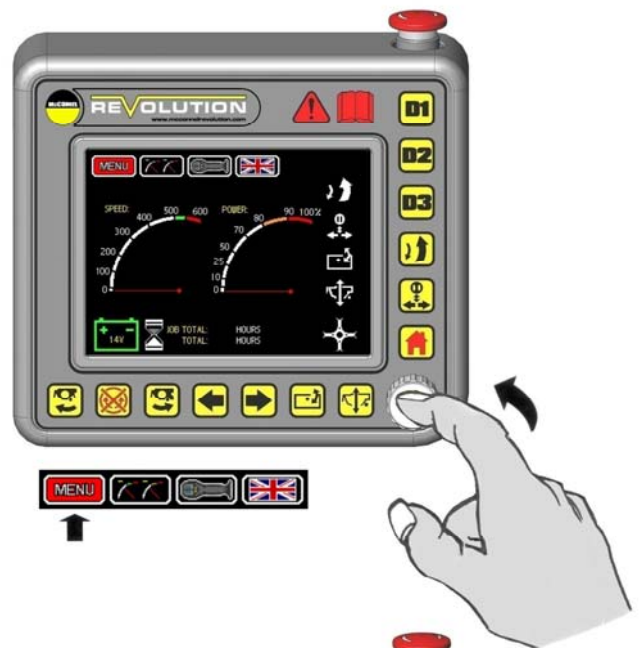

BILDSCHIRM NAVIGATION – Joystick Status Fenster



SPRACHEINSTELLUNG



- | | |
|---|---|
|  ENGLISH |  DUTCH |
|  GERMAN |  POLISH |
|  FRENCH |  SPANISH |
|  DANISH | |

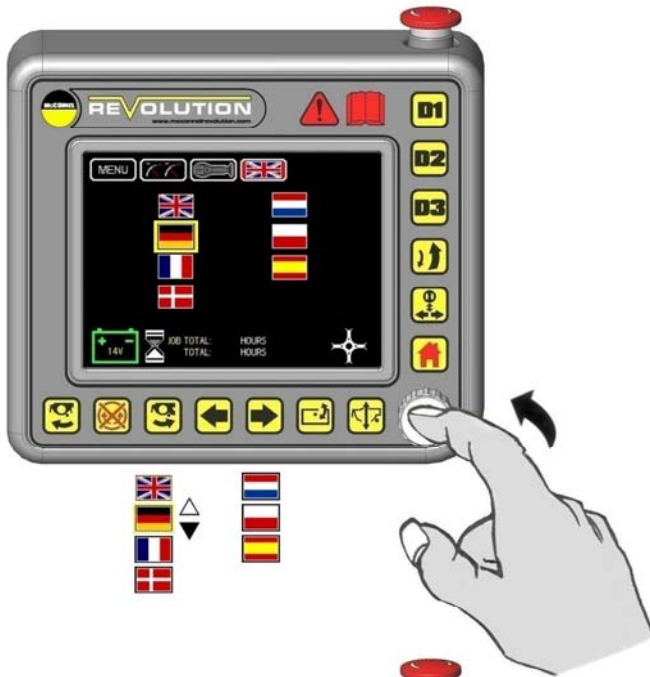

MENU-ZUGANG UND EINSTELLUNGEN

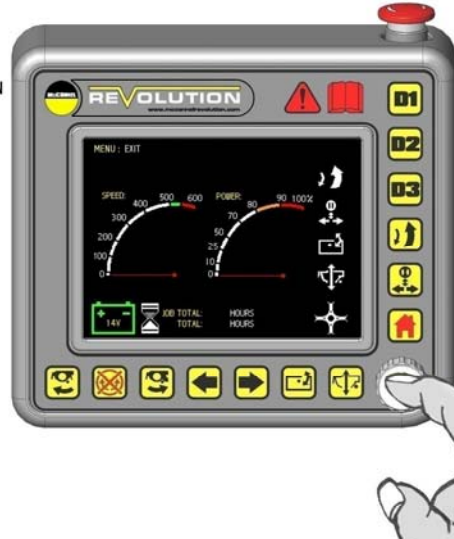

- MENU : EXIT
- EDS PID
 - ZAPFWELLE
 - ▶ TEST/KALIBRIERUNG
 - ▶ JOYSTICKEINSTELLUNGEN
 - ▶ VENTILE
 - ▶ VENTILE 2
 - ▶ EINSTELLUNGEN
 - ▶ AUSLAGE
 - ▶ AUSLAGESTOPP
 - ▶ SCHWENKBEGRENZUNG
 - D1 AUSWAHL
 - um
 - D5 AUSWAHL
 - ▶ WARNTON
 - FILTERLAUFZEIT
 - FILTERREPORT
 - ▶ INFO
 - ▶ PASSWORT

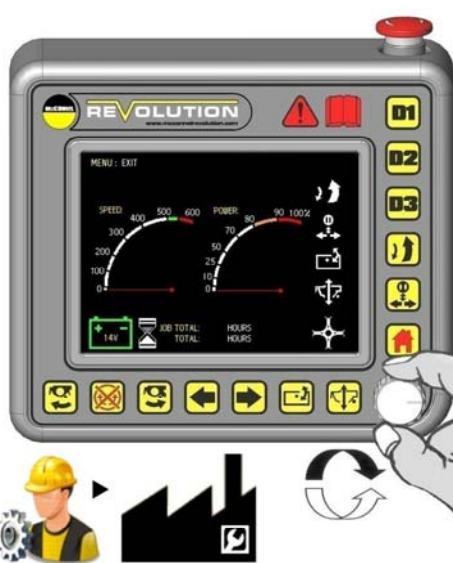

- MENU : EXIT
- EDS PID
 - ZAPFWELLE
 - ▶ TEST/KALIBRIERUNG
 - ▶ JOYSTICKEINSTELLUNGEN
 - ▶ VENTILE
 - ▶ VENTILE 2
 - ▶ EINSTELLUNGEN
 - ▶ AUSLAGE
 - ▶ AUSLAGESTOPP
 - ▶ SCHWENKBEGRENZUNG
 - D1 AUSWAHL
 - um
 - D5 AUSWAHL
 - ▶ WARNTON
 - FILTERLAUFZEIT
 - FILTERREPORT
 - ▶ INFO
 - ▶ PASSWORT

AUSLAGE WECHSEL

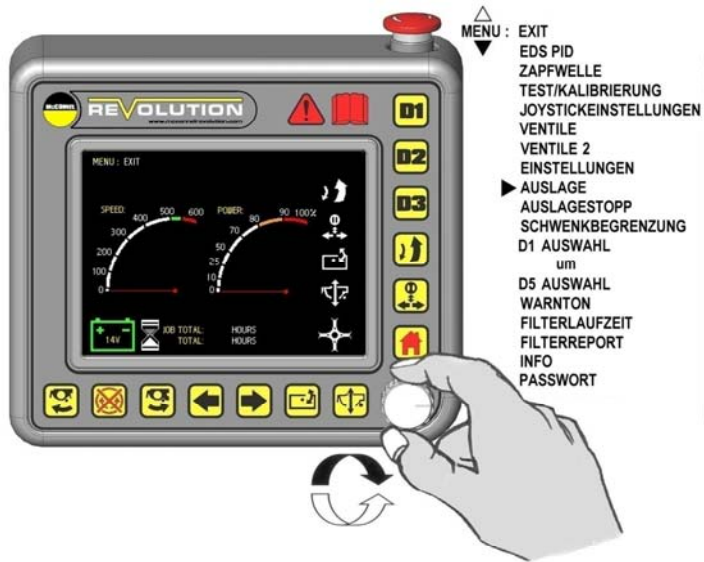

AUSLAGEBEGRENZUNG – Einstellung Auslagebegrenzung



AUSLAGEBEGRENZUNG – Entfernen Auslagebegrenzung



JOYSTICK EINSTELLUNGEN – Joystick Funktionen Wählen und Einstellen



DAUMEN : NORMALE
 B1 : SCHWENK/TELE. WECHSEL
 B2 : D1 AUSWAHL
 B3 : SCHWIMMSTELLUNG SCHALTER
 B4 : EDS SCHWIMMSTELLUNG
 FABRIKSEINSTELLUNG



DAUMEN : NORMALE
 B1 : SCHWENK/TELE. WECHSEL
 B2 : D1 AUSWAHL
 B3 : SCHWIMMSTELLUNG SCHALTER
 B4 : EDS SCHWIMMSTELLUNG
 FABRIKSEINSTELLUNG

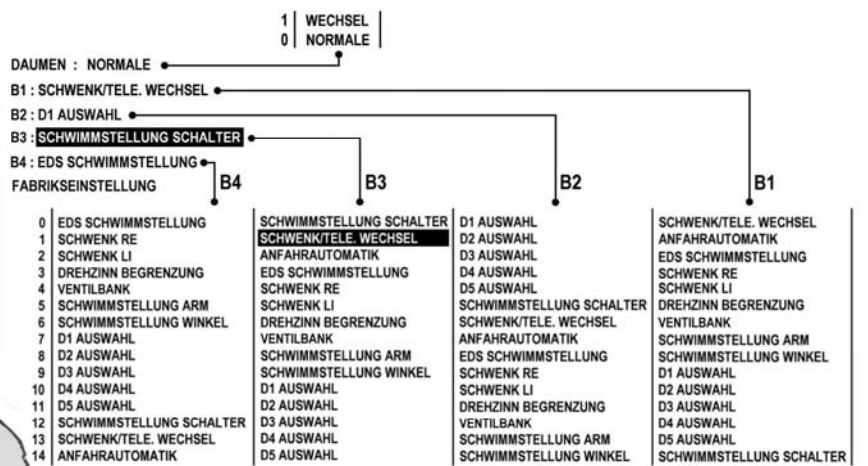

DAUMEN : NORMALE
 B1 : SCHWENK/TELE. WECHSEL
 B2 : D1 AUSWAHL
 B3 : SCHWIMMSTELLUNG SCHALTER
 B4 : EDS SCHWIMMSTELLUNG
 FABRIKSEINSTELLUNG

JOYSTICK PROBE / KALIBRIERUNG

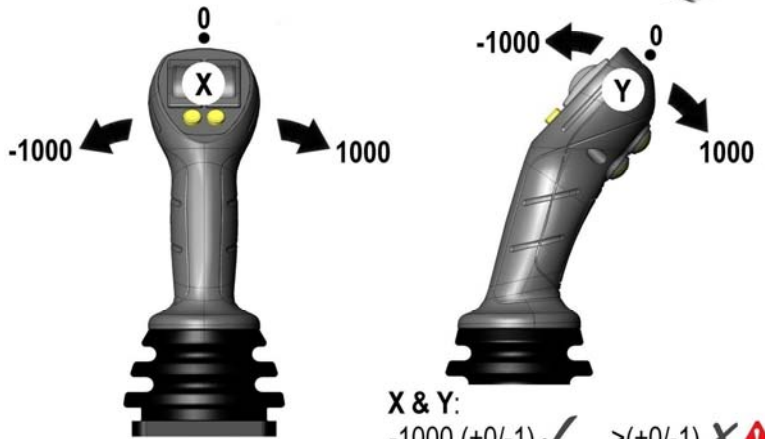
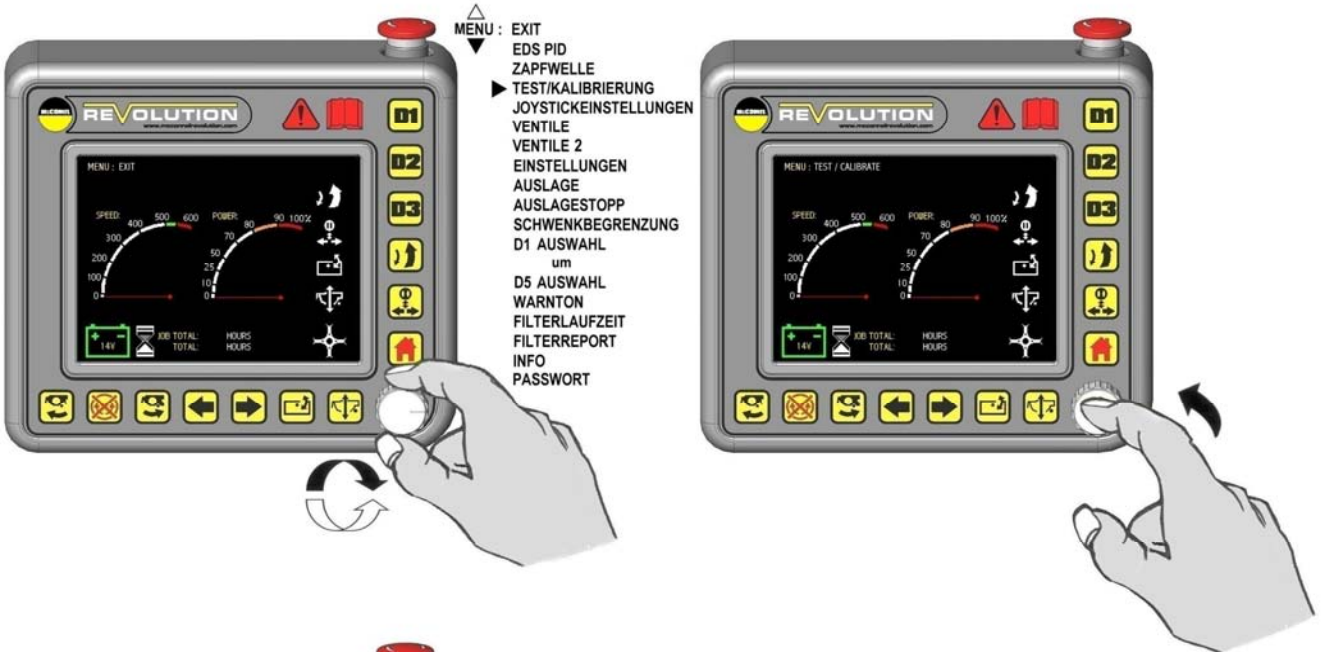

X & Y:

-1000 (+0/-1) ✓	>(+0/-1) X ⚠
0 (+0/0) ✓	>(+0/0) X ⚠
1000 (+0/-1) ✓	>(+0/-1) X ⚠

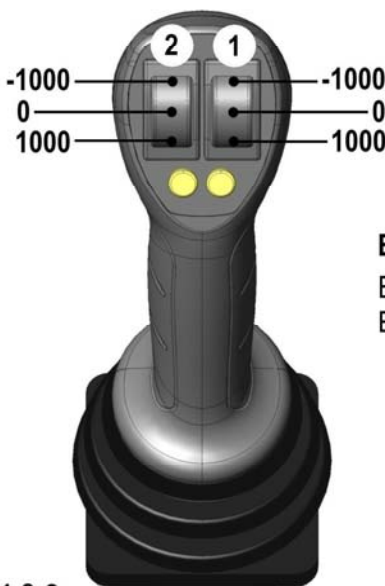

B1 / B2 / B3 / B4
 EIN / AUS ✓
 EIN / AUS X ⚠



JOYSTICK X:	0
JOYSTICK Y:	0
THUMBWHEEL 1:	0
THUMBWHEEL 2:	0
BUTTON 1:	222 OFF
BUTTON 2:	225 OFF
BUTTON 3:	250 OFF
BUTTON 4:	254 OFF
PTO SPEED:	540
RVC PRESSURE:	200
LIFT PRESSURE:	40
REACH POSITION:	55
CUTTER TOTAL:	25.4
OVER SPEED:	0.0
OVER POWER:	20.0
ARMREST POWER:	245.5
ACB POWER:	245.5
FILTER TIME:	245.5
FILTER OVER:	0.0



1 & 2:

-1000 (+0/-1) ✓	>(+0/-1) X ⚠
0 (+0/0) ✓	>(+0/0) X ⚠
1000 (+0/-1) ✓	>(+0/-1) X ⚠



VENTIL ANTWORTEINSTELLUNGEN

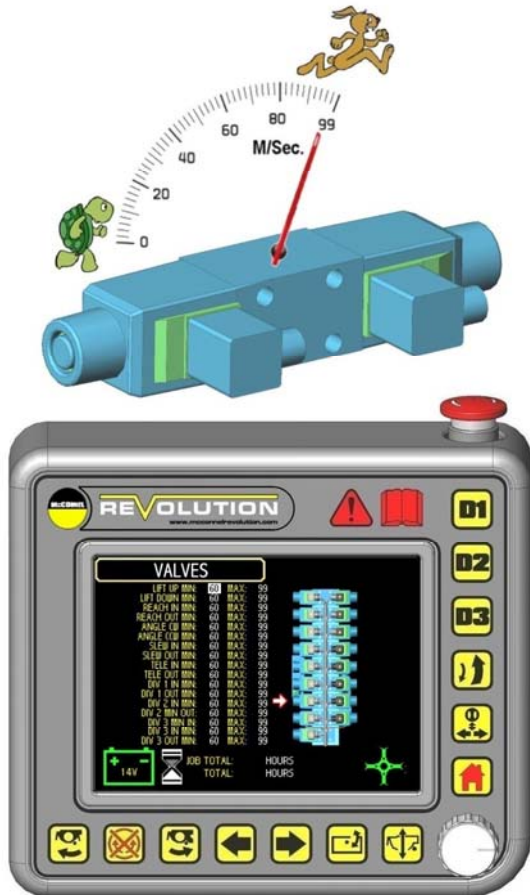

< DEFAULT SETTINGS >

LIFT UP MIN:	50	MAX:	99
LIFT DOWN MIN:	50	MAX:	99
REACH IN MIN:	60	MAX:	99
REACH OUT MIN:	60	MAX:	99
ANGLE CW MIN:	60	MAX:	99
ANGLE CCW MIN:	60	MAX:	99
SLEW IN MIN:	60	MAX:	99
SLEW OUT MIN:	60	MAX:	99
TELE IN MIN:	60	MAX:	99
TELE OUT MIN:	60	MAX:	99
DIV 1 IN MIN:	60	MAX:	99
DIV 1 OUT MIN:	60	MAX:	99
DIV 2 IN MIN:	60	MAX:	99
DIV 2 OUT MIN:	60	MAX:	99
DIV 3 IN MIN:	60	MAX:	99
DIV 3 OUT MIN:	60	MAX:	99
SLEW 2 IN MIN:	60	MAX:	99
SLEW 2 OUT MIN:	60	MAX:	99

VENTIL 2 ANTWORTEINSTELLUNGEN (Anwendbar auf Software v5.08 ab)

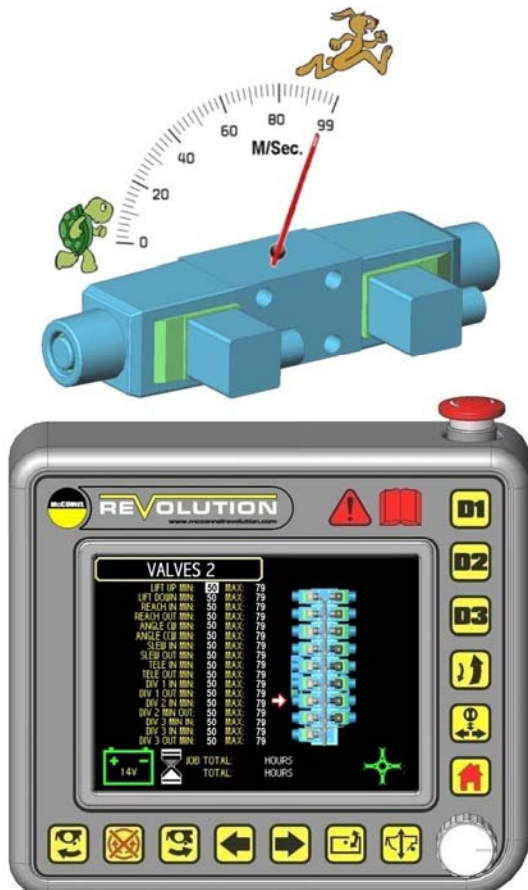

< DEFAULT SETTINGS >

LIFT UP MIN:	50	MAX:	79
LIFT DOWN MIN:	50	MAX:	79
REACH IN MIN:	50	MAX:	79
REACH OUT MIN:	50	MAX:	79
ANGLE CW MIN:	50	MAX:	79
ANGLE CCW MIN:	50	MAX:	79
SLEW IN MIN:	50	MAX:	79
SLEW OUT MIN:	50	MAX:	79
TELE IN MIN:	50	MAX:	79
TELE OUT MIN:	50	MAX:	79
DIV 1 IN MIN:	50	MAX:	79
DIV 1 OUT MIN:	50	MAX:	79
DIV 2 IN MIN:	50	MAX:	79
DIV 2 OUT MIN:	50	MAX:	79
DIV 3 IN MIN:	50	MAX:	79
DIV 3 OUT MIN:	50	MAX:	79
SLEW 2 IN MIN:	50	MAX:	79
SLEW 2 OUT MIN:	50	MAX:	79

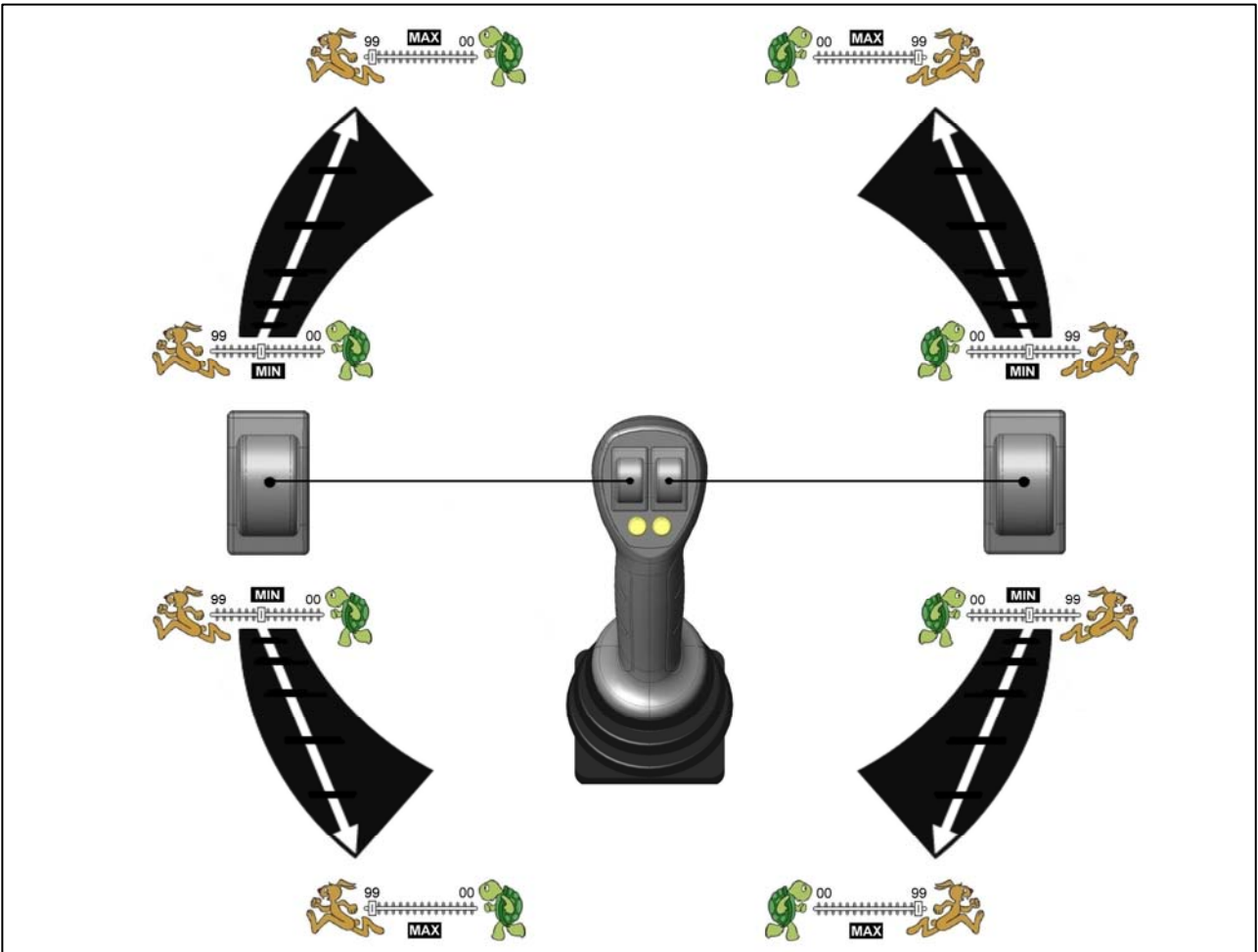
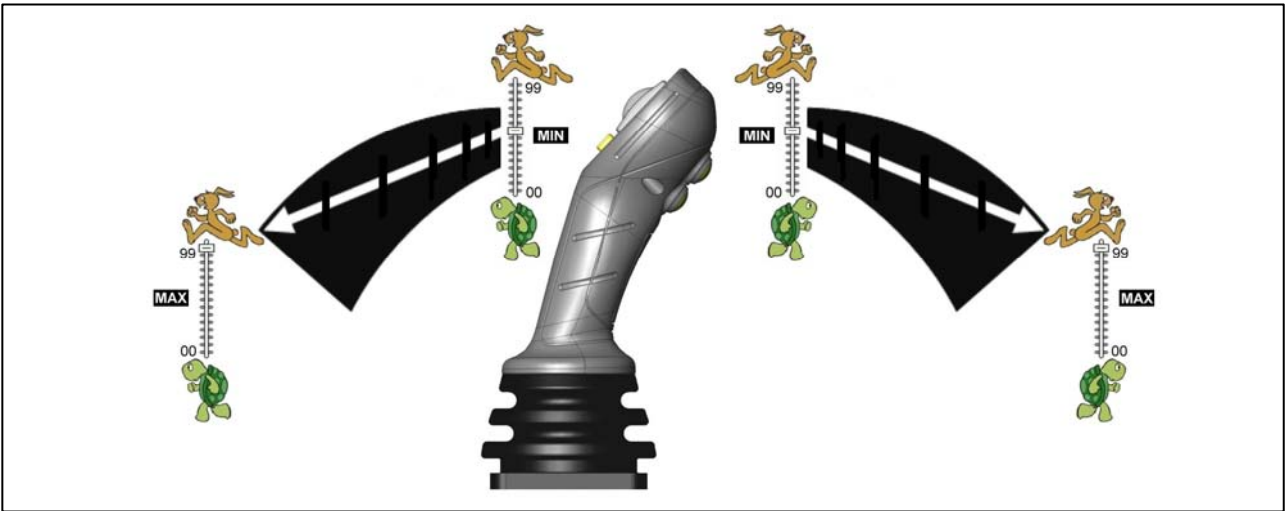
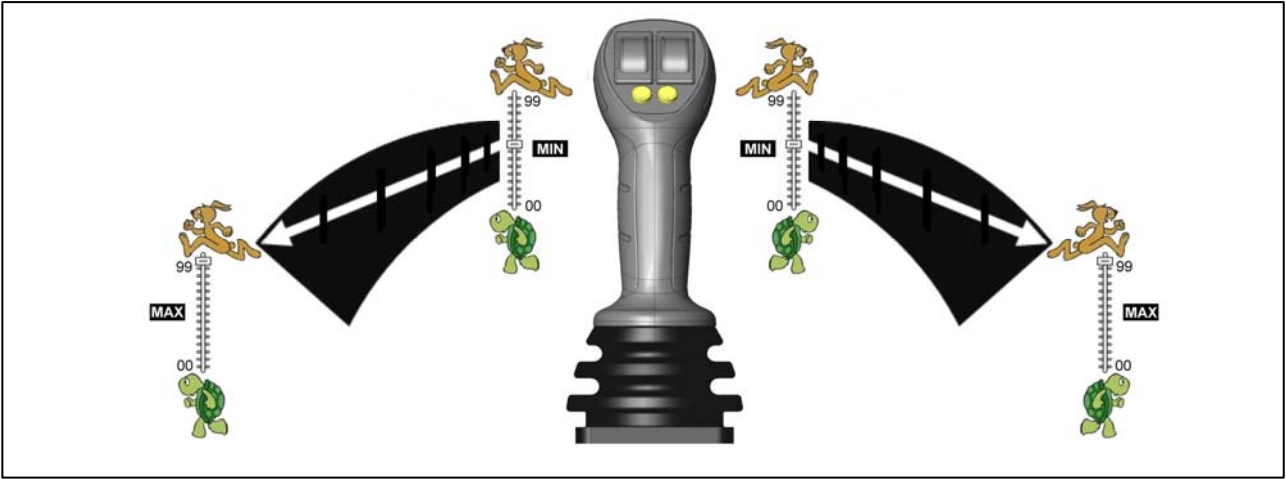

VENTIL ANTWORT ANPASSUNG



- ▲ MENU: EXIT
- ▼ EDS PID
- ▶ ZAPFWELLE
- ▶ TEST/KALIBRIERUNG
- ▶ JOYSTICKEINSTELLUNGEN
- ▶ VENTILE
- ▶ VENTILE 2
- ▶ EINSTELLUNGEN
- ▶ AUSLAGE
- ▶ AUSLAGESTOPP
- ▶ SCHWENKBEGRENZUNG
- D1 AUSWAHL
- um
- D5 AUSWAHL
- WARNTON
- FILTERLAUFZEIT
- FILTERREPORT
- INFO
- PASSWORT

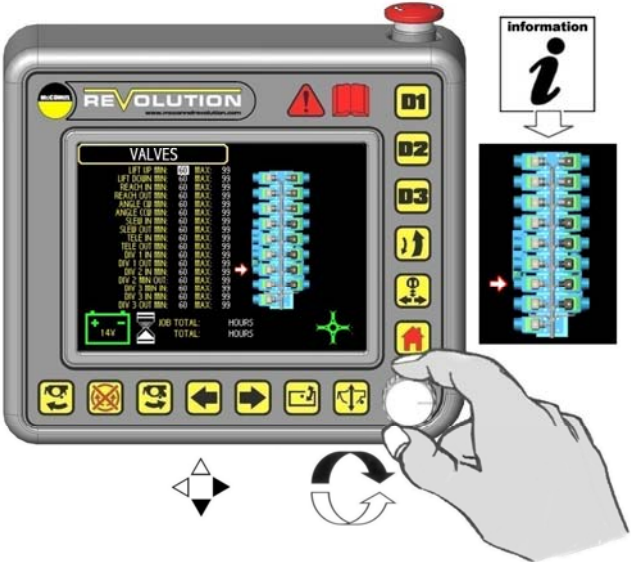

< DEFAULT SETTINGS >

LIFT UP MIN:	50	MAX:	99
LIFT DOWN MIN:	50	MAX:	99
REACH IN MIN:	60	MAX:	99
REACH OUT MIN:	60	MAX:	99
ANGLE CW MIN:	60	MAX:	99
ANGLE CCW MIN:	60	MAX:	99
SLEW IN MIN:	60	MAX:	99
SLEW OUT MIN:	60	MAX:	99
TELE IN MIN:	60	MAX:	99
TELE OUT MIN:	60	MAX:	99
DIV 1 IN MIN:	60	MAX:	99
DIV 1 OUT MIN:	60	MAX:	99
DIV 2 IN MIN:	60	MAX:	99
DIV 2 OUT MIN:	60	MAX:	99
DIV 3 IN MIN:	60	MAX:	99
DIV 3 OUT MIN:	60	MAX:	99
SLEW 2 IN MIN:	60	MAX:	99
SLEW 2 OUT MIN:	60	MAX:	99

information

MIN: 60 MAX: 99

▲ 00-99 ▼ 00-99

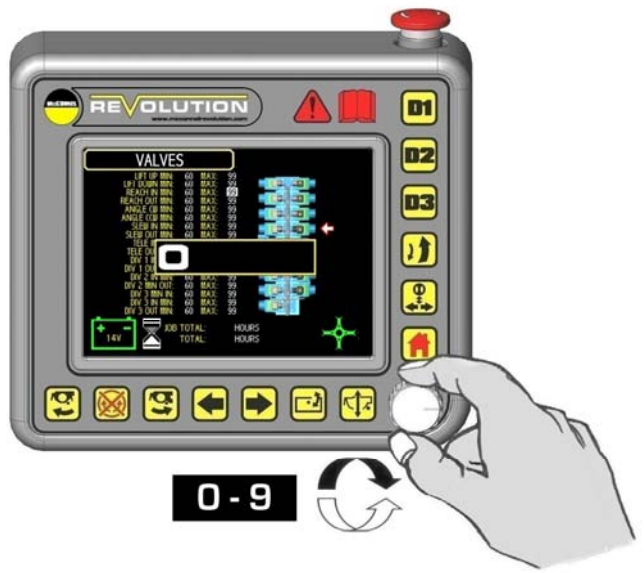

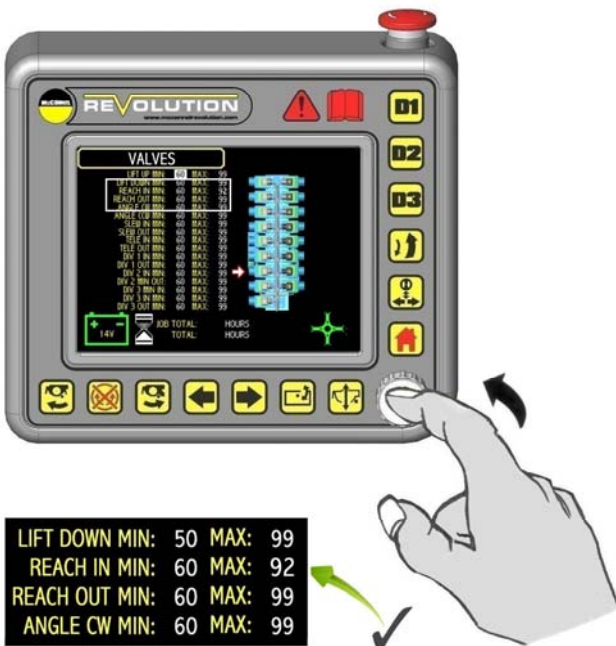
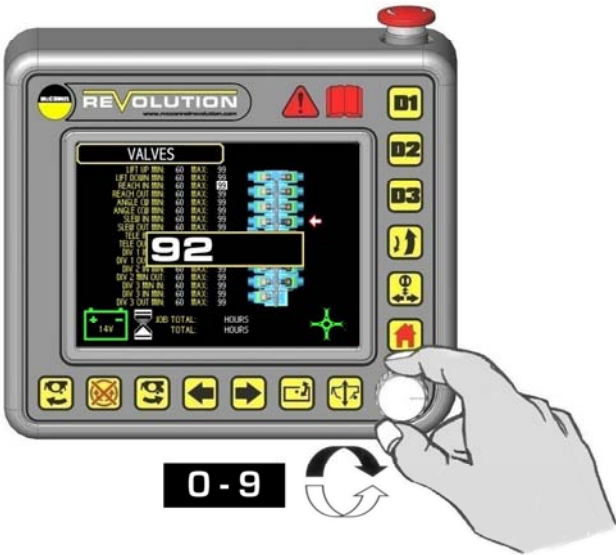
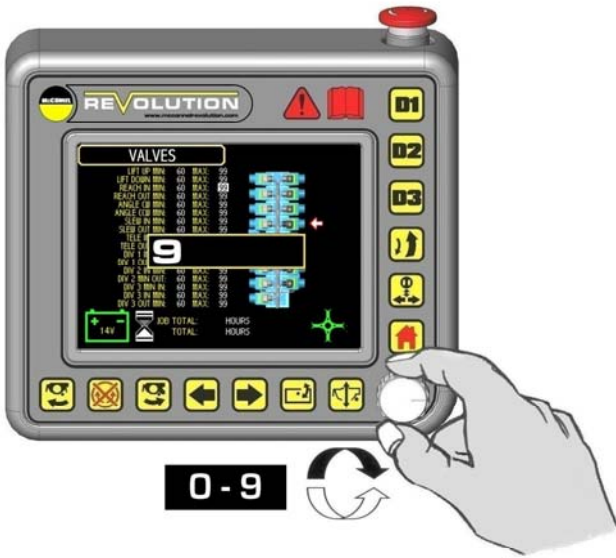



VENTIL 2 ANTWORT ANPASSUNG (Anwendbar auf Software v5.08 ab)



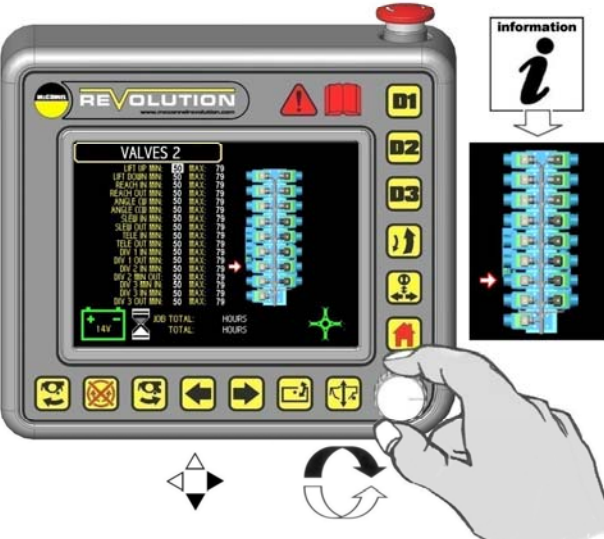

MENU: EXIT
EDS PID
ZAPFWELLE
TEST/KALIBRIERUNG
JOYSTICKEINSTELLUNGEN
VENTILE
VENTILE 2
EINSTELLUNGEN
AUSLAGE
AUSLAGESTOPP
SCHWENKBEGRENZUNG
D1 AUSWAHL
um
D5 AUSWAHL
WARNTON
FILTERLAUFZEIT
FILTERREPORT
INFO
PASSWORT



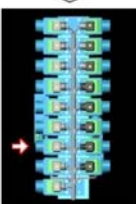

information 





< DEFAULT SETTINGS >

LIFT UP MIN:	50	MAX:	79
LIFT DOWN MIN:	50	MAX:	79
REACH IN MIN:	50	MAX:	79
REACH OUT MIN:	50	MAX:	79
ANGLE CW MIN:	50	MAX:	79
ANGLE CCW MIN:	50	MAX:	79
SLEW IN MIN:	50	MAX:	79
SLEW OUT MIN:	50	MAX:	79
TELE IN MIN:	50	MAX:	79
TELE OUT MIN:	50	MAX:	79
DIV 1 IN MIN:	50	MAX:	79
DIV 1 OUT MIN:	50	MAX:	79
DIV 2 IN MIN:	50	MAX:	79
DIV 2 OUT MIN:	50	MAX:	79
DIV 3 IN MIN:	50	MAX:	79
DIV 3 OUT MIN:	50	MAX:	79
SLEW 2 IN MIN:	50	MAX:	79
SLEW 2 OUT MIN:	50	MAX:	79

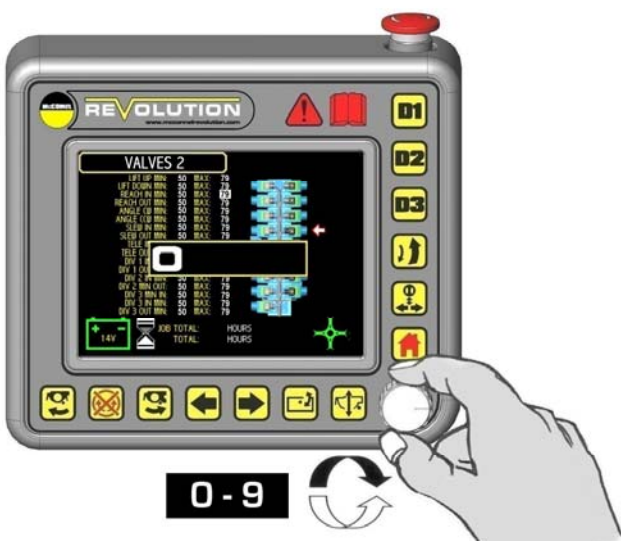

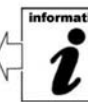
information 

MIN: 50 MAX: 79

00-99 00-99

0-9

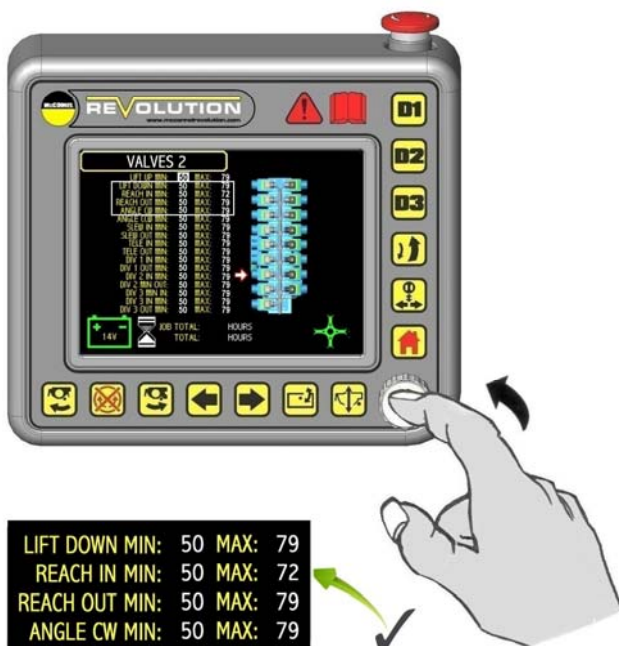
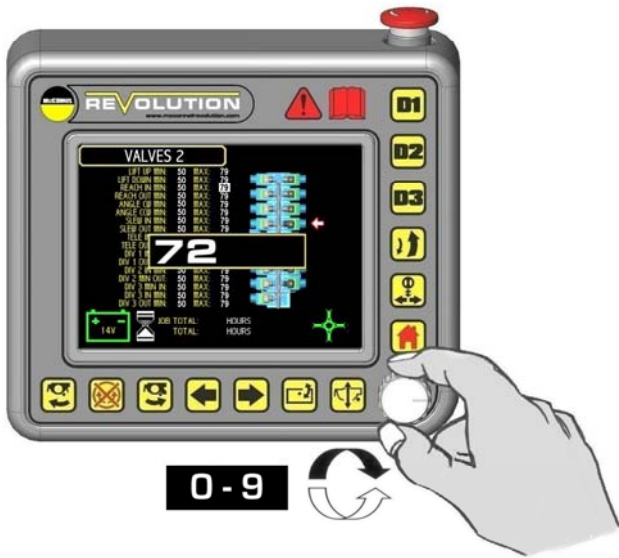
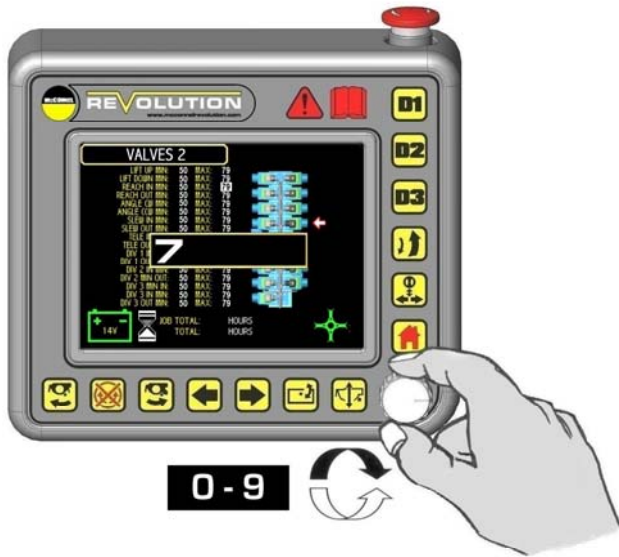

VENTILBANK FEATUREAUSWAHL

JOYSTICK SETUP

THUMB : NORMALE
 B1 : SLEW / TELE SWAP
 B2 : DIVERTER 1
 B3 : ROLLER FLOOR
 B4 : EDS FLOTT
 RESET DEFAULT

1 - 14x

0	EDS SCHWIMMSTELLUNG	SCHWIMMSTELLUNG SCHALTER	D1 AUSWAHL	SCHWENK/TELE. WECHSEL
1	SCHWENK RE	SCHWENK/TELE. WECHSEL	D2 AUSWAHL	ANFAHRAUTOMATIK
2	SCHWENK LI	ANFAHRAUTOMATIK	D3 AUSWAHL	EDS SCHWIMMSTELLUNG
3	DREHZINN BEGRENZUNG	EDS SCHWIMMSTELLUNG	D4 AUSWAHL	SCHWENK RE
4	VENTILBANK	SCHWENK RE	D5 AUSWAHL	SCHWIMMSTELLUNG SCHALTER
5	SCHWIMMSTELLUNG ARM	SCHWENK LI	SCHWIMMSTELLUNG SCHALTER	SCHWENK/TELE. WECHSEL
6	SCHWIMMSTELLUNG WINKEL	DREHZINN BEGRENZUNG	ANFAHRAUTOMATIK	EDS SCHWIMMSTELLUNG
7	D1 AUSWAHL	VENTILBANK	SCHWENK/TELE. WECHSEL	SCHWENK RE
8	D2 AUSWAHL	SCHWIMMSTELLUNG ARM	EDS SCHWIMMSTELLUNG	SCHWENK LI
9	D3 AUSWAHL	SCHWIMMSTELLUNG WINKEL	SCHWENK RE	DREHZINN BEGRENZUNG
10	D4 AUSWAHL	D1 AUSWAHL	SCHWENK LI	VENTILBANK
11	D5 AUSWAHL	D2 AUSWAHL	DREHZINN BEGRENZUNG	SCHWIMMSTELLUNG ARM
12	SCHWIMMSTELLUNG SCHALTER	D3 AUSWAHL	VENTILBANK	SCHWIMMSTELLUNG WINKEL
13	SCHWENK/TELE. WECHSEL	D4 AUSWAHL	SCHWIMMSTELLUNG ARM	SCHWIMMSTELLUNG SCHALTER
14	ANFAHRAUTOMATIK	D5 AUSWAHL	SCHWIMMSTELLUNG WINKEL	

1 | WECHSEL
0 | NORMALE

DAUMEN : NORMALE

B1 : SCHWENK/TELE. WECHSEL

B2 : D1 AUSWAHL

B3 : SCHWIMMSTELLUNG SCHALTER

B4 : EDS SCHWIMMSTELLUNG
FABRIKSEINSTELLUNG

Wahl

Wahl

Wahl

Wahl

Ausgewählt

VENTIL 2 AKTIVIERUNG / DEAKTIVIERUNG

B1

B2

B4

B3

EIN / AUS
AUS / EIN

REVOLUTION

REVOLUTION

SPEED: 0 100 200 300 400 500 600

POWER: 0 25 50 75 80 90 100%

14V

JOB TOTAL: TOTAL

HOURS: HOURS

WARNTÖNE EIN / AUS

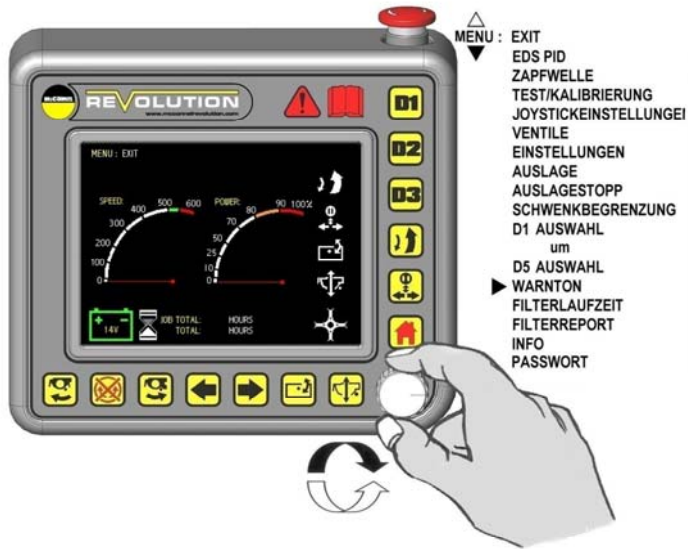

FILTER GEBRAUCHZEITEN WARNUNG – Anfangsfilter (12 Stunden)

MENU : FILTER GEBRAUCHZEITEN

@ 8 Stunden
 GEBRAUCHZEIT : 8.0
 ÜBERSCHREITUNG : 0.0

@ 10 Stunden
 GEBRAUCHZEIT : 10.0
 ÜBERSCHREITUNG : 0.0

@ 12 Stunden
 GEBRAUCHZEIT : 12.0
 ÜBERSCHREITUNG : 0.0

12+ Stunden
 GEBRAUCHZEIT : 12.1
 ÜBERSCHREITUNG : 0.1

RESET GEBRAUCHZEIT

McConnell Part No. 8401089
 Date: 20/07/2012
 XXXX
 XXXX
 MFG No.

500hrs
 8401089
 ISO46
 ISO68

GEBRAUCHZEIT : 0.0

FILTER GEBRAUCHZEITEN WARNUNG – Wiedereinbau-Filter (500 Stunden)

MENU : FILTER GEBRAUCHZEITEN

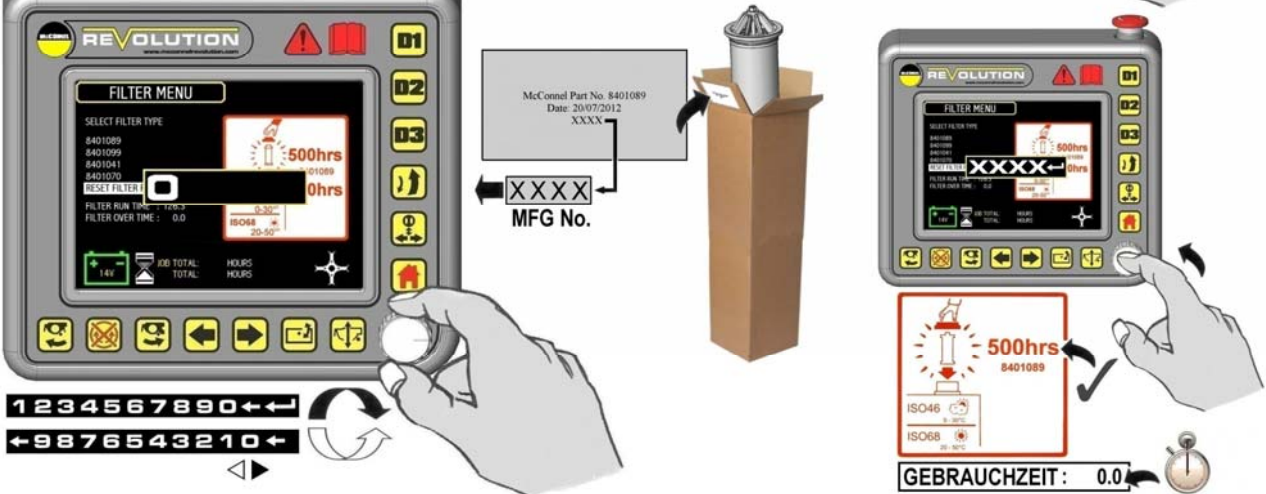
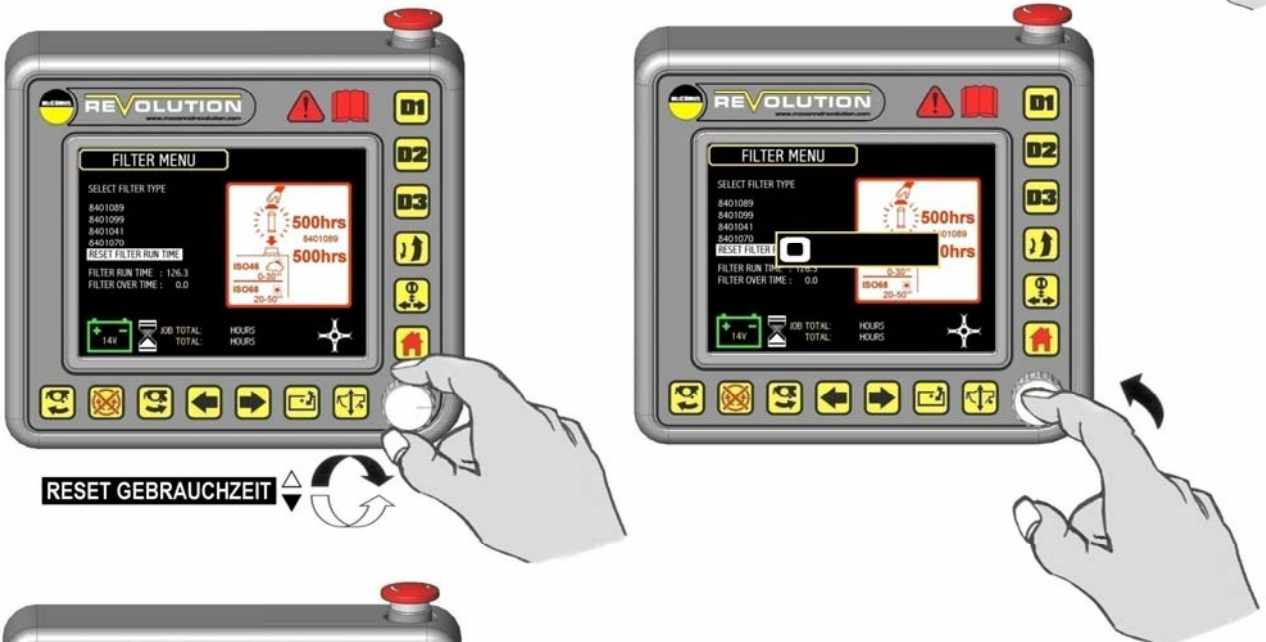
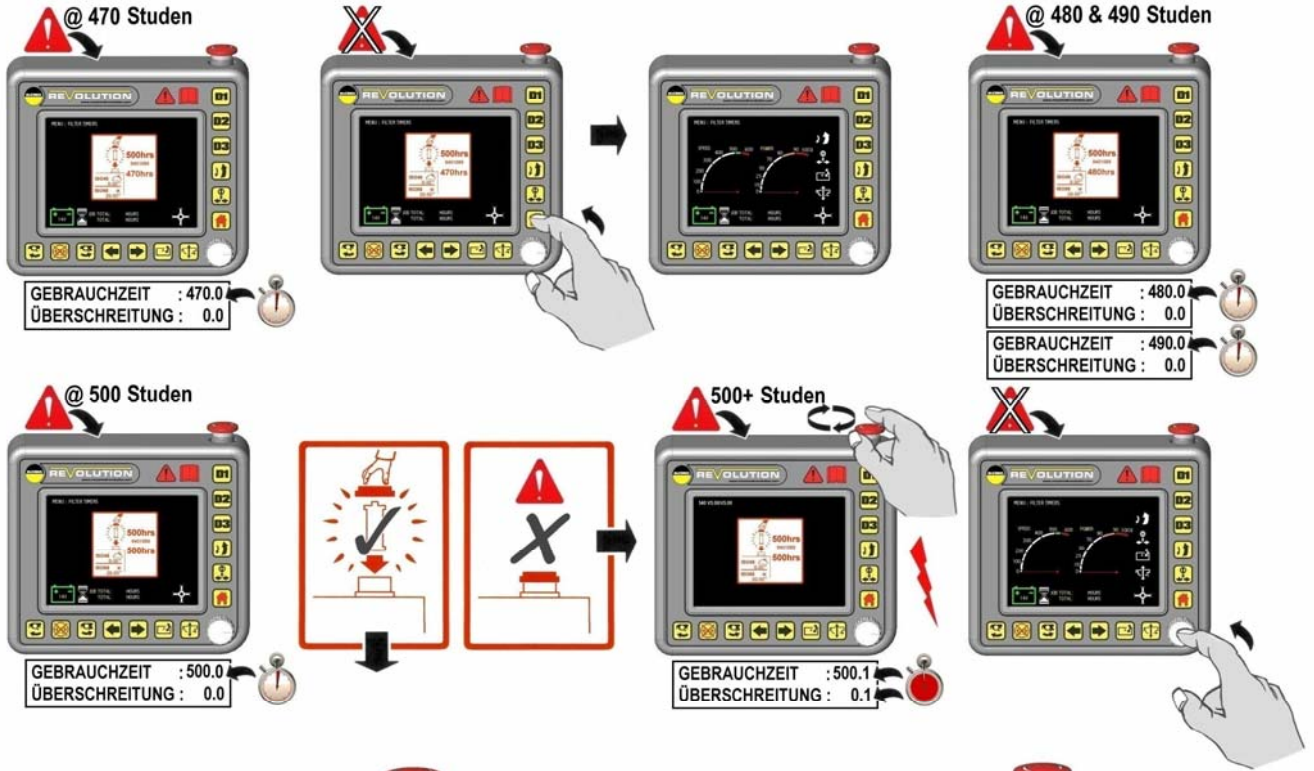

1234567890←
 ←9876543210

BESTANDTEILE ANGESCHLOSSEN WARNUNG

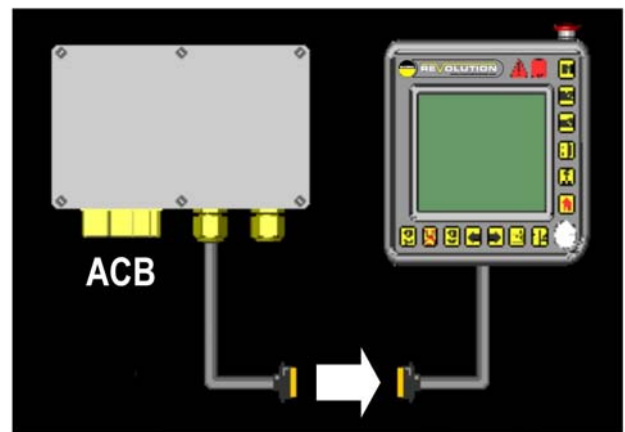
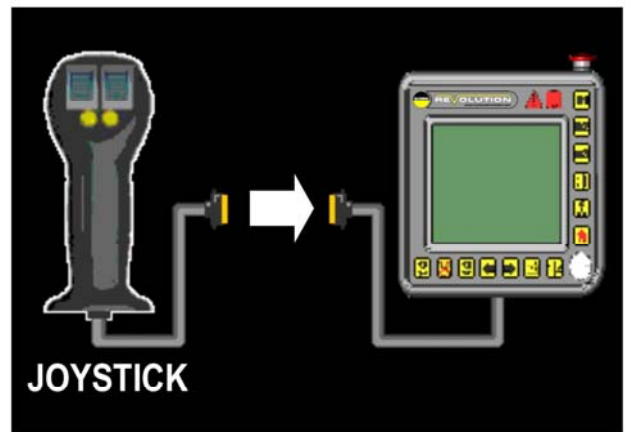

ARBEITSBILDSCHIRM – Überbelastung Drehzahl & Überbelastung Leistung Warnung Fenster



ENGLISH ◀▶ GERMAN

<p>ENGLISH</p> <p>WORK SCREEN</p> <p>1 SPEED 2 POWER 3 JOB TOTAL 4 TOTAL 5 OVER SPEED 6 OVER POWER</p> <p>JOYSTICK SCREEN</p> <p>1 SLEW 2 ANGLE 3 TELE 4 ACTIVE FLOAT 5 EDS FLOAT 6 SLEW/TELE SWAP 7 ACTIVE FLOAT 8 DIVERTER 1 9 DIVERTER 2 10 DIVERTER 3 11 AUTO RESET 12 LIFT FLOAT 13 HEAD FLOAT</p> <p>MENU TXT</p> <p>1 EXIT 2 PASSWORD 3 FILTER TIMERS 4 WARNING SOUNDS 5 D3 ASSIGN 6 D2 ASSIGN 7 D1 ASSIGN 8 SLEW STOP 9 REACH STOP 10 REACH 11 SETTINGS 12 VALVES 13 JOYSTICK SETUP 14 TEST / CALIBRATE 15 PTO 16 EDS (SETTINGS) PID</p> <p>FILTER MENU</p> <p>1 SELECT FILTER TYPE 2 RESET FILTER RUN TIME 3 FILTER RUN TIME 4 FILTER OVER TIME</p> <p>WARNING BUZZER</p> <p>1 WARNING BUZZER DISABLED 2 WARNING BUZZER ENABLED</p> <p>D3 ASSIGN</p> <p>1 HEAD ORBITOR 2 MIDCUT 3 VFR 4 HEAD ROTATOR 5 HYDRAULIC HOOD 6 HYDRAULIC ROLLER 7 TELE 8 HEAD ROTATOR 9 HYDRAULIC CHUTE 10 DEBRIS BLOWER 11 POWER BOOST</p> <p>SLEW STOP</p> <p>1 SET SLEW STOP 1 2 SET SLEW STOP 2 3 REMOVE STOPS</p> <p>REACH STOPS</p> <p>1 SET REACH STOP 1 2 SET REACH STOP 2 3 REMOVE STOPS</p> <p>SETTINGS</p> <p>1 POWER METER 2 PTO FITTED 3 XDUCER TYPE 4 MAX POWER 5 ROTOR REVERSE</p>	<p>DEUTSCH</p> <p>ARBEITSFENSTER</p> <p>1 DREHZAHL 2 LEISTUNG 3 AUFTRAGSTUNDEN 4 BETRIEBSSTUNDEN TOT 5 ÜBER DREHZAHL 6 ÜBERBELASTUNG</p> <p>JOYSTICK FENSTER</p> <p>1 ARM SCHWENKEN 2 KOPF DREHEN 3 TELESKOPIEREN 4 SCHWIMMSTELLUNG SCHALTER 5 EDS SCHWIMMSTELLUNG 6 SCHWENK/TELE. WECHSEL 7 SCHWIMMSTELLUNG SCHALTER 8 FUNKTIONWECHSEL 1 9 FUNKTIONWECHSEL 2 10 FUNKTIONWECHSEL 3 11 ANFAHRAUTOMATIK 12 SCHWIMMSTELLUNG ARM 13 SCHWIMMSTELLUNG KOPF</p> <p>MENU TEXT</p> <p>1 BEENDEN 2 KENNWORT 3 FILTER GEBRAUCHZEITEN 4 WARNTÖNE 5 D3 FUNKTION WAHL 6 D2 FUNKTION WAHL 7 D1 FUNKTION WAHL 8 ZWENKBEGRENZUNG 9 AUSLAGEBEGRENZUNG 10 AUSLAGE 11 EINSTELLUNGEN 12 VENTILE 13 JOYSTICK EINSTELLUNGEN 14 PROBE/KALIBRIERUNG 15 ZAPFWELLE 16 EDS EINSTELLUNGEN</p> <p>FILTER MENU</p> <p>1 TYP WAHLEN 2 RESET GEBRAUCHZEIT 3 GEBRAUCHZEIT 4 ÜBERSCHREITUNG</p> <p>WARNTON</p> <p>1 AUSSCHALTEN 2 EINSCHALTEN</p> <p>D3 AUSWAHL</p> <p>1 KOPF NEIGUNG 2 VORN VERSETZTEN ARM 3 EINSTELBARE VORN VERSETZTEN ARM 4 KOPF DREHTISCH 5 FRONTHAUBE VERSTELLUNG 6 STÜTZWALZE VERSTELLUNG 7 TELESKOPIEREN 8 KOPF DREHTISCH 9 AUSWURF VERSTELLUNG 10 GEBLÄSE 11 STEUER GESCHWINDIGKEIT</p> <p>SCHWENKBEGRENZUNG</p> <p>1 EINST.BEGRENZUNG 1 2 EINST.BEGRENZUNG 2 3 BEGRENZUNGS FREIGABE</p> <p>AUSLAGEBEGRENZUNG</p> <p>1 EINST.BEGRENZUNG 1 2 EINST.BEGRENZUNG 2 3 BEGRENZUNGS FREIGABE</p> <p>EINSTELLUNGEN</p> <p>1 LEISTUNGS ANZEIGE 2 DREHZAHL ANGABE 3 SENSOR TYP 4 MAX.LEISTUNG 5 DREHZINN UMKEHREN</p>	<p>ENGLISH</p> <p>SETTINGS</p> <p>6 EDS PRO 7 REACH CALIB 8 SET REACH IN 9 SET REACH OUT 10 D1 / PROP 11 D2 / PROP 12 D3 / PROP 13 SLEW 2 14 RESET TO DEFAULT</p> <p>VALVES</p> <p>1 LIFT UP 2 LIFT DOWN 3 REACH IN 4 REACH OUT 5 ANLGE CW 6 ANGLE CCW 7 TELE IN 8 TELE OUT 9 SLEW IN 10 SLEW OUT 11 DIV 1 IN 12 DIV 1 OUT 13 DIV 2 IN 14 DIV 2 OUT 15 SLEW 2 IN 16 SLEW 2 OUT</p> <p>JOYSTICK SETUP</p> <p>1 NORMAL 2 SWAP 3 THUMBWHEELS 4 ACTIVE FLOAT 5 SLEW / TELE SWAP 6 AUTO RESET 7 EDS FLOAT 8 LIFT FLOAT 9 HEAD FLOAT 10 DIVERTER 1 11 DIVERTER 2 12 DIVERTER 3</p> <p>TEST / CALIBRATE</p> <p>1 JOYSTICK 2 THUMBWHEEL 3 BUTTON 4 PTO SPEED 5 RCV PRESSURE 6 LIFT PRESSURE 7 REACH POSITION 8 CUTTER TOTAL 9 OVER SPEED 10 OVER POWER 11 ARM REST POWER 12 ACB POWER 13 FILTER TIME 14 FILTER OVER</p> <p>EDS (SETTINGS) PID</p> <p>1 ENABLE 2 DISABLE 3 FLOAT PRESSURE 4 SOFT 5 MED 6 HARD 7 REACH POSITION 8 OIL PRESSURE</p> <p>MISC</p> <p>1 ACB DISCONNECT 2 JS DISCONNECT 3 JS FAULT 4 ON 5 OFF 6 UPDATING ARM REST 7 UPDATING ACB 8 FAULT 9 PASSWORD 10 THUMB</p>	<p>DEUTSCH</p> <p>EINSTELLUNGEN</p> <p>6 ARM SCHWIMMSTELLUNG PRO 7 AUSLAGE KALIBRIEREN 8 EINST.AUSLAGE NAHE 9 EINST.AUSLAGE FERN 10 D1 / PROP 11 D2 / PROP 12 D3 / PROP 13 ZWENKUNG 2 14 FABRIKSEINSTELLUNG</p> <p>VENTILE</p> <p>1 HEBEN 2 ZENKEN 3 AUSLAGE EIN 4 AUSLAGE AUS 5 WINKEL RE 6 WINKEL LI 7 TELE EIN 8 TELE AUS 9 SCHWENK RE 10 SCHWENK LI 11 DIV 1 EIN 12 DIV 1 AUS 13 DIV 2 EIN 14 DIV 2 AUS 15 SCHWENK 2 RE 16 SCHWENK 2 LI</p> <p>JOYSTICK EINSTELLUNGEN</p> <p>1 NORMALE BEDIENUNG 2 INVERSIONS BEDIENUNG 3 DAUMENRAD 4 SCHWIMMSTELLUNG SCHALTER 5 SCHWENK/TELE WECHSEL 6 ANFAHRAUTOMATIK 7 EDS SCHWIMMSTELLUNG 8 SCHWIMMSTELLUNG ARM 9 SCHWIMMSTELLUNG KOPF 10 FUNKTIONWECHSEL 1 11 FUNKTIONWECHSEL 2 12 FUNKTIONWECHSEL 3</p> <p>TEST/KALIBRIERUNG</p> <p>1 JOYSTICK 2 DAUMENRAD 3 DRÜCKTASTE 4 ZAPFWELLE DREHZAHL 5 LEISTUNGS SENSOR 6 HEBEN SENSOR 7 AUSLAGE SENSOR 8 BETRIEBSSTUNDEN TOT. 9 ÜBER DREHZAHL. 10 ÜBERBELASTUNG 11 ARMLEHNE SPEISUNG 12 ACB SPEISUNG 13 FILTER STUNDEN 14 FILTER MEHR GEBRAUCH</p> <p>EDS EINSTELLUNG</p> <p>1 EINSCHALTEN 2 AUSSCHALTEN 3 SCHWIMMSTELLUNG DRÜCK 4 LEICHT 5 MITTEL 6 SCHWER 7 AUSLAGE POSITION 8 ÖL DRÜCK</p> <p>SONSTIGE</p> <p>1 ACB NICHT ANGESCHLOSSEN 2 JS NICHT ANGESCHLOSSEN 3 JS FEHLER 4 EIN 5 AUS 6 AKTUALISIEREN ARMLEHNE 7 AKTUALISIEREN ACB 8 STORUNG 9 KENNWORT 10 DAUMEN</p>
---	---	--	---



McConnel Limited, Temeside Works, Ludlow, Shropshire SY8 1JL. England.
Telephone: 01584 873131. Facsimile: 01584 876463. www.mcconnel.com