

V4 PROPORTIONAL CONTROLS

POWER ON / OFF (Emergency Stop)

Rotate Clockwise to Power On – control unit will emit a single beep and screen will display the selected PTO speed, software version and the McConnel name. Press to Power Off.

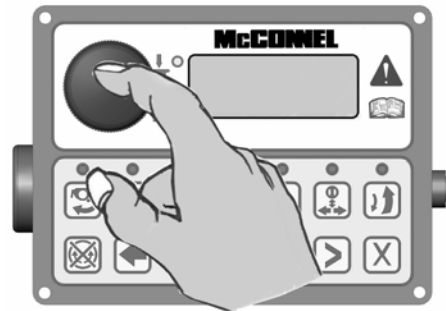
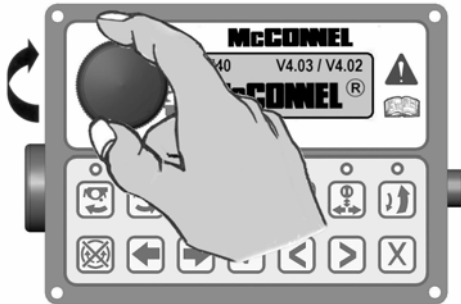

ROTOR START – Uphill Cutting

This button starts the rotor for ‘uphill’ cutting – when the button is pressed the control unit will emit a single beep, the LED light will illuminate and the screen will momentarily display ‘FLAIL START ✓’.

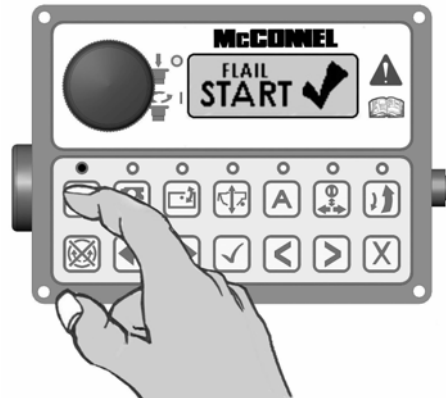

ROTOR START – Downhill Cutting

This button starts the rotor for ‘downhill’ cutting – when the button is pressed the control unit will emit a single beep, the LED light will illuminate and the screen will momentarily display ‘FLAIL START ✓’.

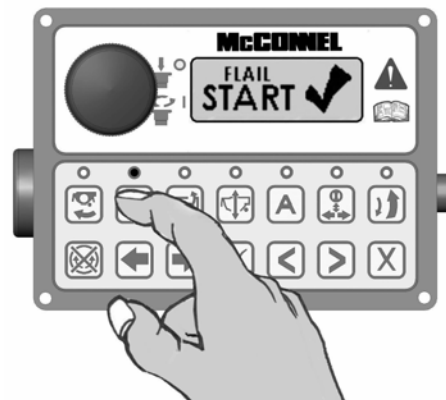

ROTOR STOP

This button stops the rotor – when the button is pressed the control unit will emit a single beep and the screen will momentarily display ‘FLAIL STOP ✓’ – the LED lights above both rotor start buttons will be illuminated for approximately 10 seconds, during this period the rotor start buttons will be disabled to allow sufficient time for the rotor to power down. When the LED lights go out the rotor direction can be changed or the rotor allowed to stop.

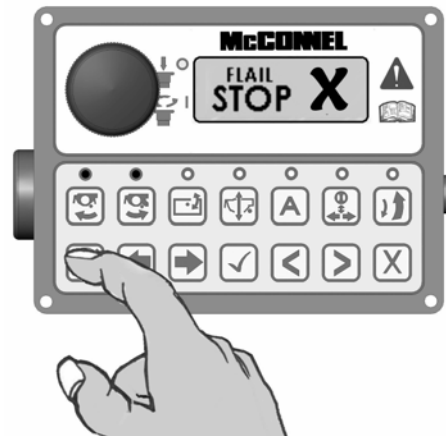

WARNING: The LED lights going out do not indicate that the rotor has stopped rotating, it signifies only that the oil flow to the rotor has ceased sufficient for the direction of rotation to be changed - therefore when stopping a rotor it must be noted that it will continue to freewheel for a considerable length of time after the stop button has been activated, in some case this can be up to 40 seconds.

HEAD ANGLE FLOAT

There are 2 methods available for selection and de-selection of this function; activation via the control unit - refer to #1 below, or activation via the joystick controls - refer to #2 below.

1. Pressing the Head Angle Float button – when activated the control unit will emit a single beep, the LED light will illuminate and the screen will momentarily display 'ANGLE FLOAT ✓' pressing the button again will deselect the function – the control unit will emit a single beep, the LED light will go out and the screen will momentarily display 'ANGLE FLOAT X'.

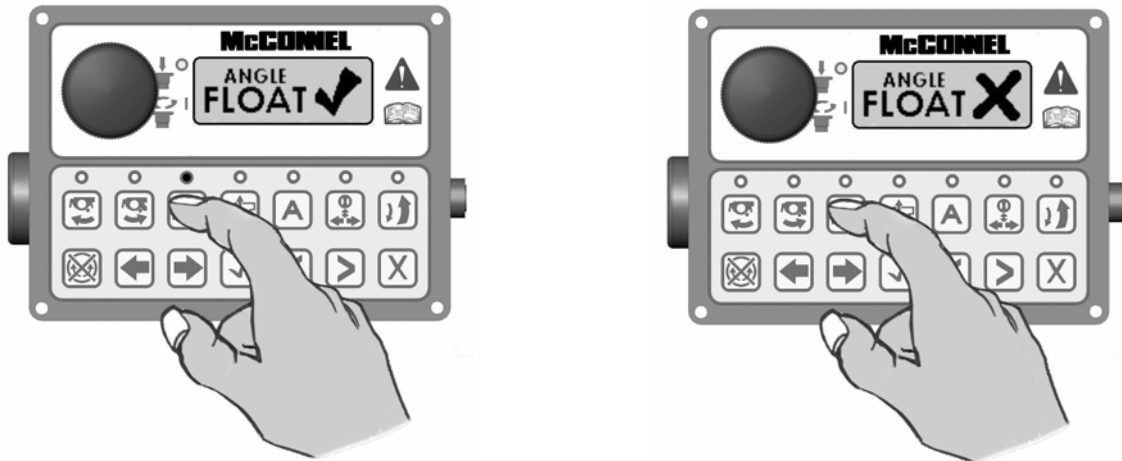

2. Press and hold in the lower frontal button (B1) on the joystick control and roll the left hand thumbwheel (T1) forwards – the control unit will emit a single beep, the LED light will illuminate and the screen will momentarily display 'ANGLE FLOAT ✓'.

To deselect press and hold in the lower frontal button (B1) on the joystick control and roll the left hand thumbwheel (T1) backwards – the control unit will emit a single beep, the LED light will go out and the screen will momentarily display 'ANGLE FLOAT X'.

NOTE: When selecting or deselecting the function, the thumbwheel (T1) should be allowed to return to its centre position before releasing the lower frontal button (B1).

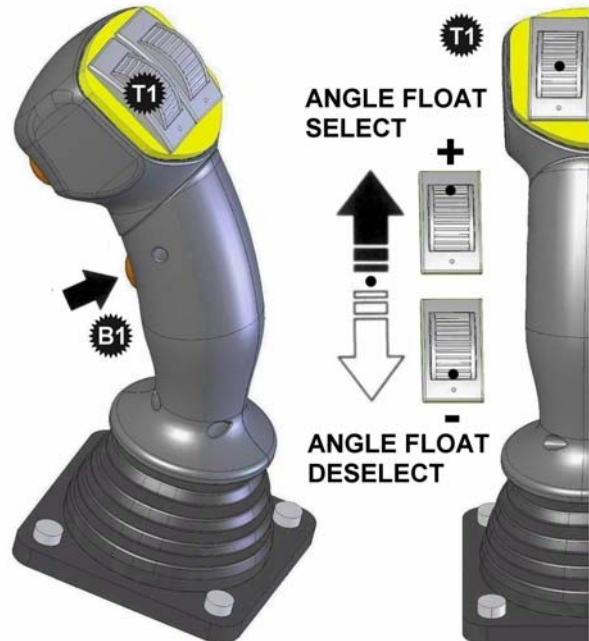

NOTE: By default operation of thumbwheels T1 and T2 in conjunction with button B1 activates Head Angle Float and EDS/Lift Float respectively. These controls can, if required, be swapped over so that the thumbwheels operate the opposing functions – this procedure is performed by accessing the settings menu on the control unit via the screen and menu buttons.

EDS FUNCTION (EDS Models) / LIFT FLOAT (Non EDS Models)

There are 2 methods available for selection and de-selection of this function; activation via the control unit - refer to #1 below, or activation via the joystick controls - refer to #2 below.

1. Pressing the EDS / Lift Float button will activate the relevant function – when activated the control unit will emit a single beep, the LED light will illuminate and the screen will momentarily display 'LIFT FLOAT ✓'. Pressing the button again will deselect the function – the control unit will emit a single beep, the LED light will go out and the screen will momentarily display 'LIFT FLOAT X'.

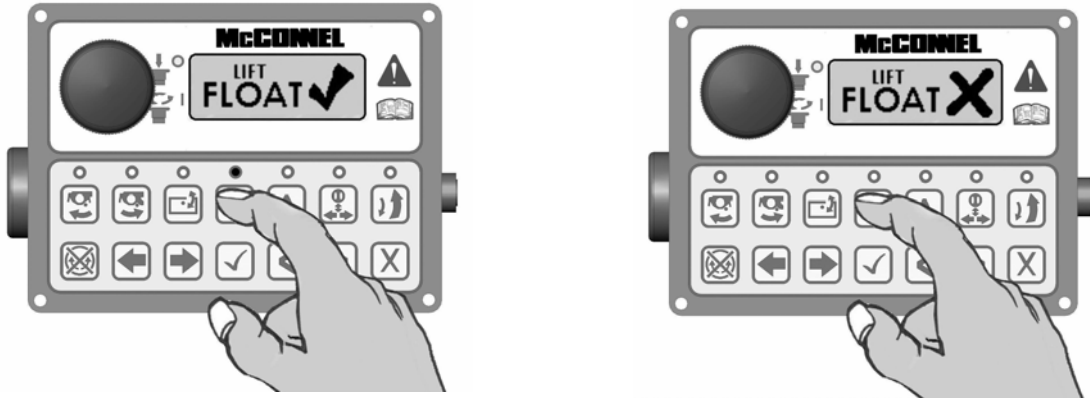

Press and hold in the lower frontal button (B1) on the joystick control and roll the right hand thumbwheel (T2) forwards – the control unit will emit a single beep, the LED light will illuminate and the screen will momentarily display 'LIFT FLOAT ✓'. To deselect press and hold in the lower frontal button (B1) on the joystick control and roll the right hand thumbwheel (T2) backwards – the control unit will emit a single beep, the LED light will go out and the screen will momentarily display 'LIFT FLOAT X'.

NOTE: When selecting or deselecting the function, the thumbwheel (T2) should be allowed to return to its centre position before releasing the lower frontal button (B1).



All models with v4.08 software onwards: With the function engaged subsequent operation of button B1 on the joystick or the [✓] button on the control unit will alternately disable and enable all active floats.

EDS models with pre v4.08 software: With the function engaged and the rotor running EDS settings (SOFT – MED – HARD) will automatically be displayed on the control unit screen and can be scrolled through using button B1 on the joystick or the tick [✓] button on the control unit, if the rotor is not running the EDS settings can manually be viewed on the screen by pressing either [◀] [▶] buttons on the control unit and scrolling to the EDS work screen.

NOTE: On machines fitted with EDS and Lift Float only one function can be used at any one time (EDS needs to be Activated/De-Activated via the on-screen menu)

AUXILIARY FUNCTION CONTROL

There are 3 possible types of auxiliary service control as described in A, B & C below – the particular type used will be dependant on the build specification of the machine. Control operation of the function for all types remains the same (*see below*).

A) Diverter Valve System Utilising an Existing Service (*Physical Diverter Valve*)

The control selects either of the two diverter valves for the operation of additional equipment that may be fitted to the machine such as: Directional Ram, Orbiter Head Kit, Hydraulic Roller etc.

B) 6/7 Service Manifold Systems (*Electronic Diverter Valve*)

Only available on stackable manifold systems either as a factory fitted option or as an aftermarket kit, in the case of the latter 'D1 and/or D2 PROP' will need to be changed from 'N' to 'Y' within 'options' of the setup menu on initial installation of the kit.

C) Integrated Debris Blower

Operated by D1 on machines with standard arm or D2 on machines with Tele, Midcut or VFR arms.

There are 2 methods of control available for selection and de-selection of the functions; activation via the control unit - *refer to #1 below*, or activation via the joystick controls - *refer to #2 below*.

1. Pressing the button momentarily will select Diverter Valve #1 – when activated the control unit will emit a single beep, the LED light will illuminate and the screen will momentarily display 'DIVERTER VALVE 1 ✓'. Pressing the button again momentarily will deactivate diverter #1, the screen will display 'DIVERTER VALVE 1 X'
Holding the button in for 2 seconds will select Diverter Valve #2 – when selected it remains active until it is subsequently deselected by holding the button in again for 2 seconds.

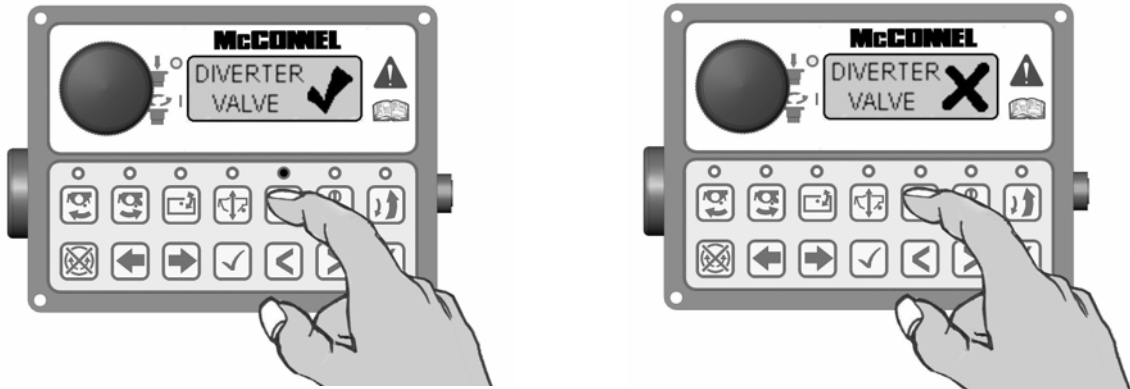

2. Pressing the upper frontal button (B2) on the joystick momentarily will select Diverter Valve #1 – when activated the control unit will emit a single beep, the LED light will illuminate and the screen will momentarily display 'DIVERTER VALVE 1 ✓'. Pressing the button again momentarily will deactivate diverter #1, the screen will display 'DIVERTER VALVE 1 X'
Holding button (B2) in for 2 seconds will select Diverter Valve #2 – when selected it remains active until it is subsequently deselected by holding the button in again for 2 seconds.



BREAKAWAY – 3RD RAM SWAP

This function swaps over the controls used to operate Breakaway and 3RD Ram. By default, Breakaway operation is performed with the right hand thumbwheel (T2) and 3RD Ram operation with the [◀] [▶] buttons on the control unit - in the swapped mode these will be the opposite way around and the LED on the control unit will be lit to indicate that the swapped mode is selected.

Swapping these controls is performed via the control unit - *refer to #1 below*. On machines installed with pre v4.08 software the same function could also be performed via the joystick controls – *for these models only refer also to #2 below*.

NOTE: 'BREAKAWAY/3RD RAM SWAP' mode is displayed on the control box screen as 'SLEW/TELE SWAP'.

1. Press the swap button once to select swap mode – when activated the control unit will emit a single beep, the LED light will illuminate and the screen will momentarily display 'SLEW/TELE SWAP ✓'. Pressing the button again will deselect the function – the control unit will emit a single beep, the LED light will go out and the screen will momentarily display 'SLEW/TELE SWAP X'.

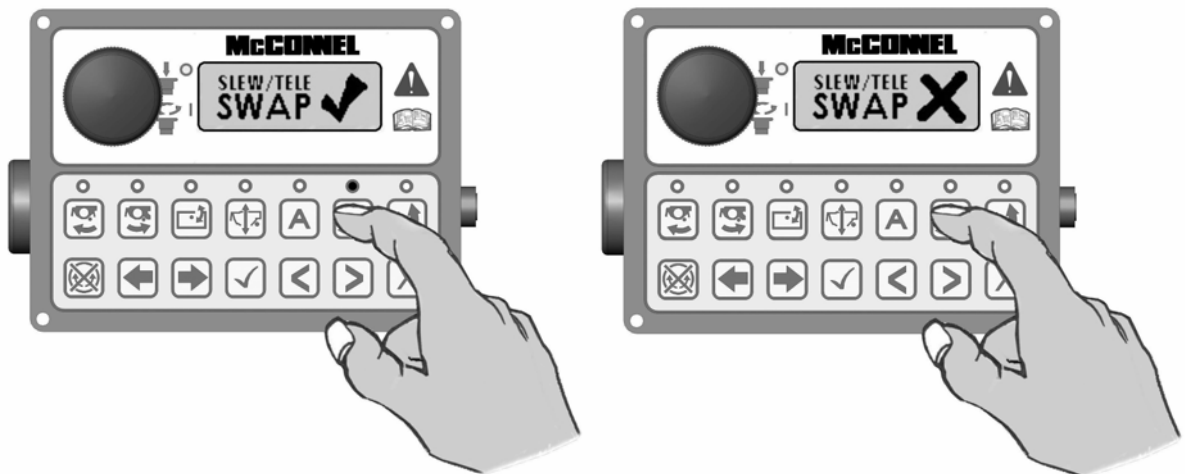

Models with pre v4.08 software only

2. Press the joystick's lower frontal button (B1) once to select swap mode – when activated the control unit will emit a single beep, the LED light will illuminate and the screen will momentarily display 'SLEW/TELE SWAP ✓'. De-selection is with subsequent use of the same button - the control unit will emit a single beep, the LED light will go out and the screen will momentarily display 'SLEW/TELE SWAP X'.



AUTO RESET

This button is for the selection and de-selection of the Auto Reset function – pressing the button once will activate Auto Reset, the control unit will emit a single beep, the LED light will illuminate and the screen will momentarily display 'AUTO RESET ✓'. Pressing the button again will deselect the function – the control unit will emit a single beep, the LED light will go out and the screen will momentarily display 'AUTO RESET X'.

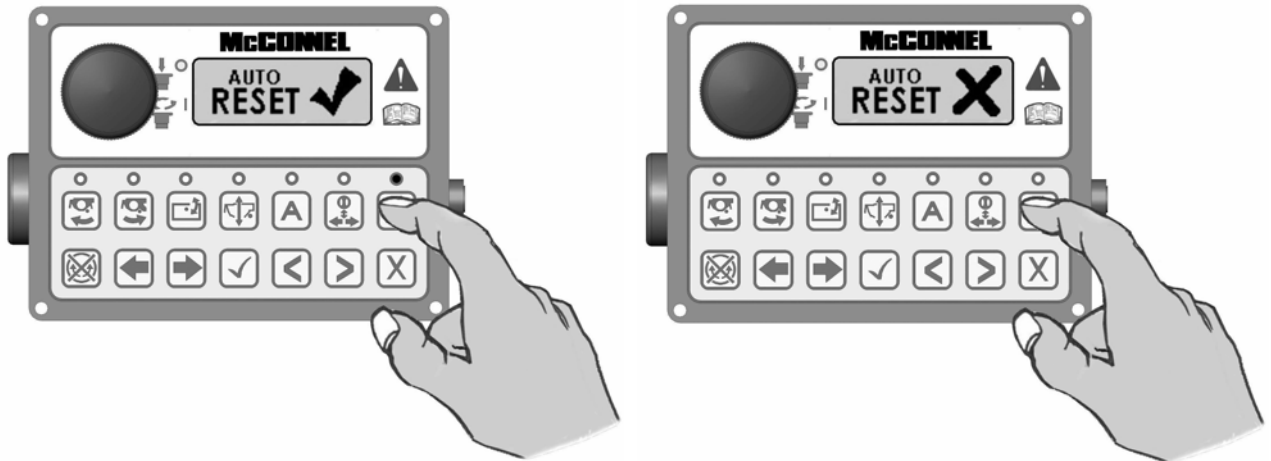

V4 JOYSTICK CONTROLS - Buttons & Thumbwheels Operation



NOTE: By default operation of thumbwheels T1 and T2 in conjunction with button B1 activates Head Angle Float and EDS/Lift Float respectively. These controls can, if required, be swapped over so that the thumbwheels operate the opposing functions – this procedure is performed by accessing the settings menu on the control unit via the screen and menu buttons.

LH/RH Swap Shortcut; Press and hold ✓ & X on Control Unit for 3 seconds (unit will 'bleep' to confirm).

FLOAT SELECTION & DE-SELECTION

Operate thumbwheels to their furthest points (+ or -) to select or deselect float functions.

FLOAT ACTIVATION

Hold button B1 in conjunction with Thumbwheel T1 or T2 operation to activate required float mode - thumbwheels must be rotated to their furthest point to select or de-select the feature

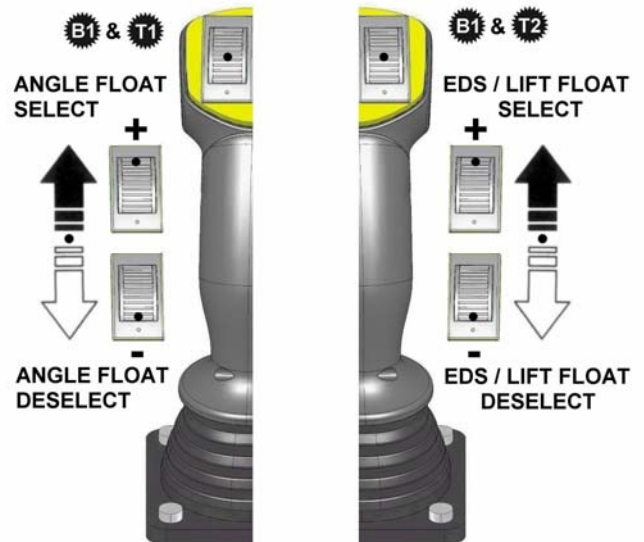

ANGLE & BREAKAWAY OPERATION

Rotate thumbwheels in required direction.

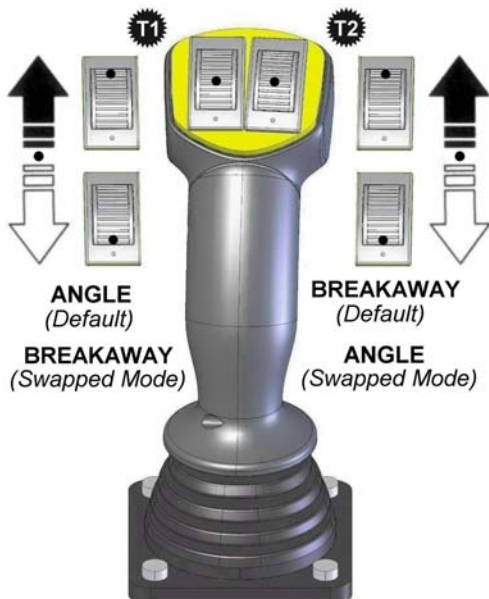

DIVERTER VALVE SELECTION

Diverter selection is via button B2

DIVERTER VALVES

Press once to activate DV #1
 Press & hold to activate DV #2
 (de-activated on release of button)



ARMHEAD OPERATION – JOYSTICK CONTROLS

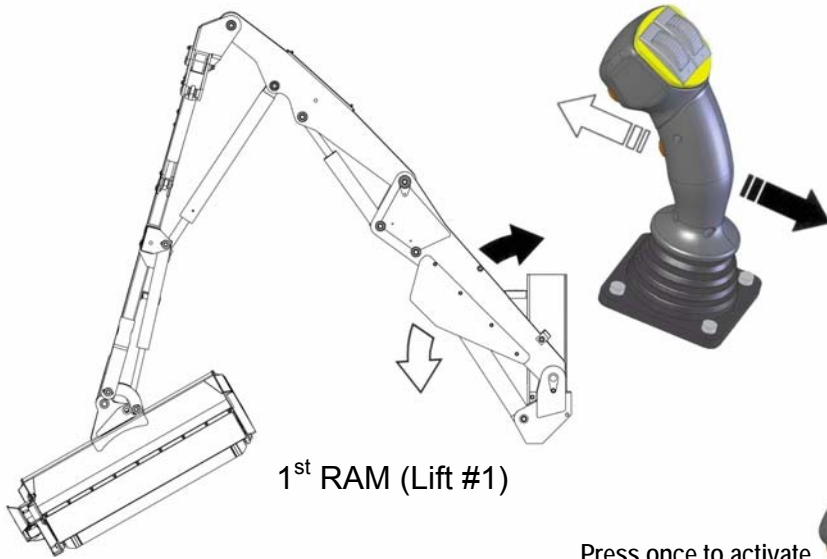

1st RAM (Lift #1)

Press once to activate
Re-press to de-activate

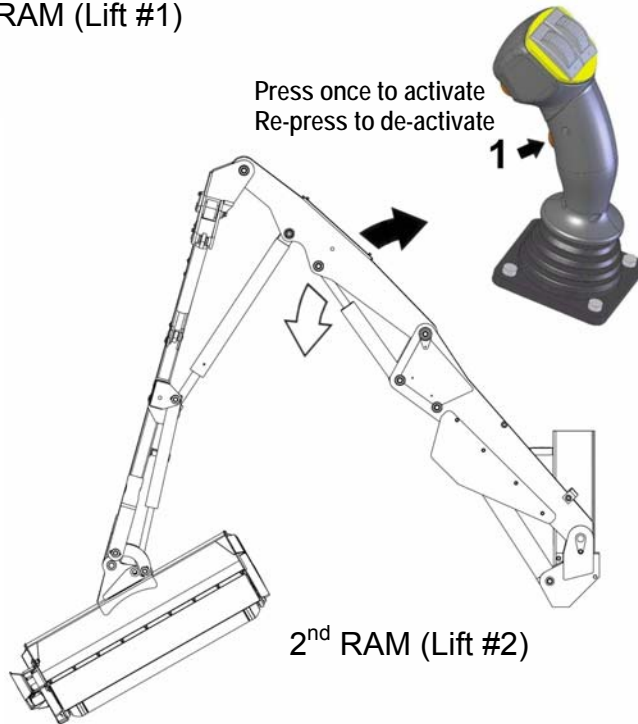

2nd RAM (Lift #2)

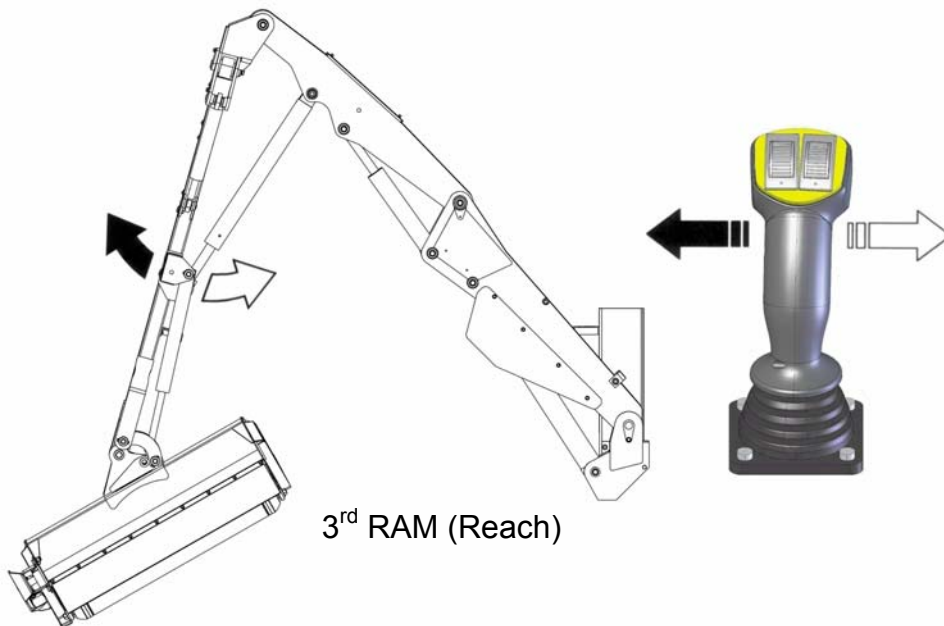

3rd RAM (Reach)

ARMHEAD OPERATION – JOYSTICK CONTROLS

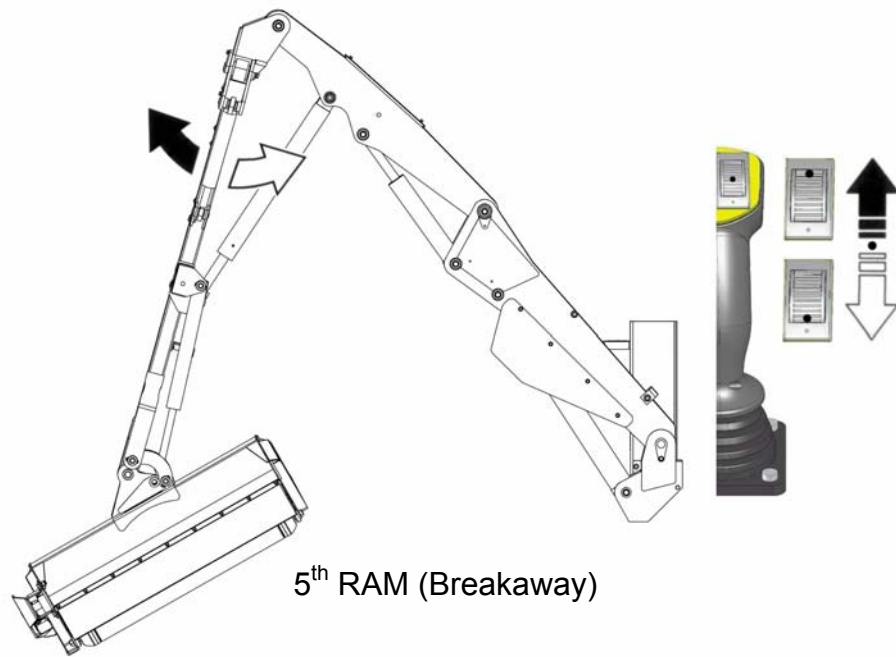
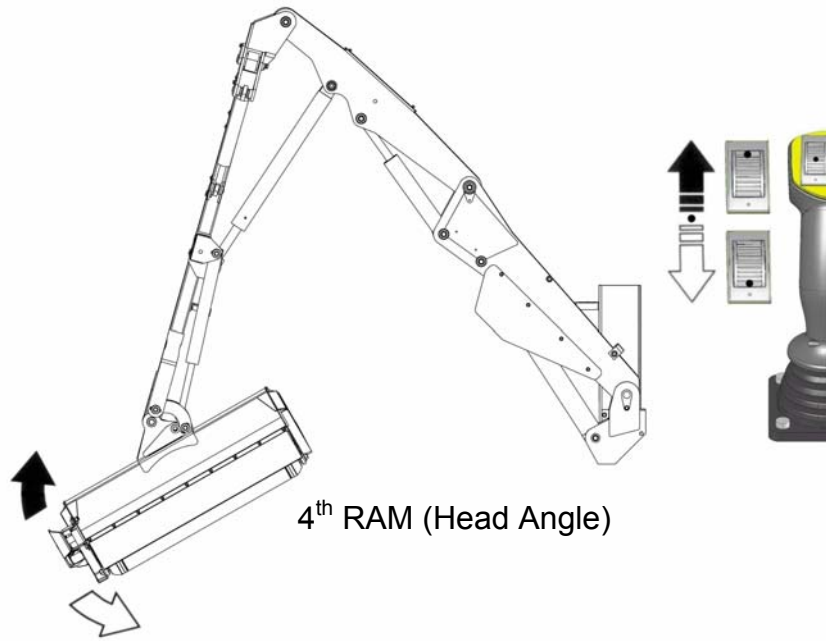

V4 CONTROL UNIT – Screen Access & Menu Buttons

Power on/off switch (E/Stop)

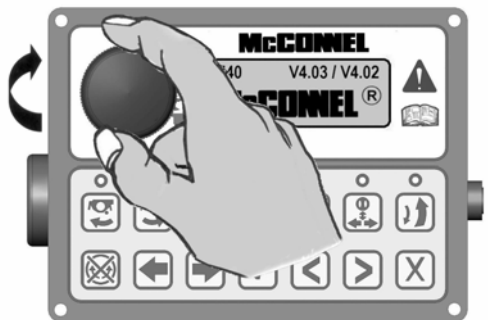

Speaker (audible confirmation)

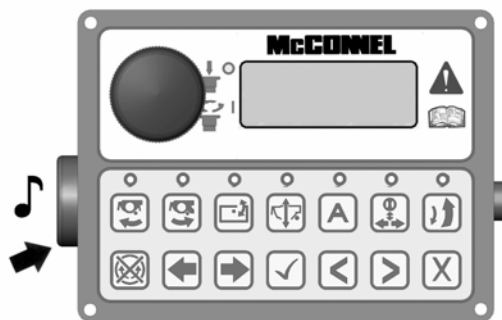

Control unit emits an audible confirmation 'beep' when the buttons are pressed.

Command Button [✓]

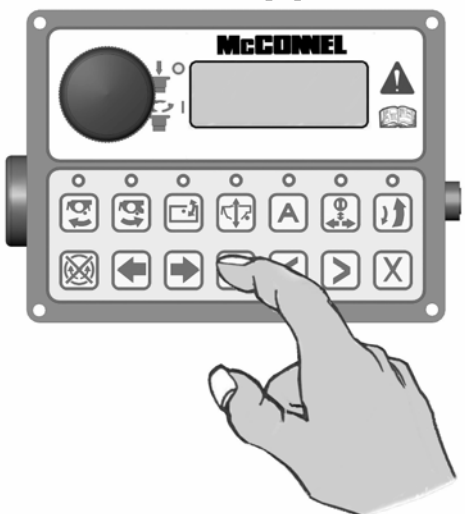

Command Button [X]

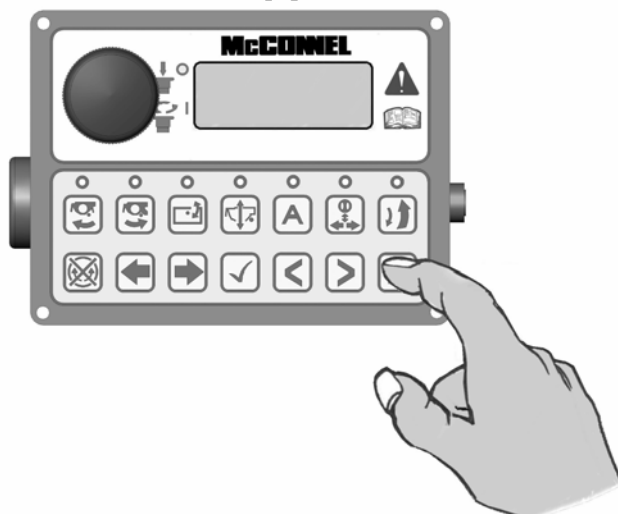

Navigate Forward Button [>]

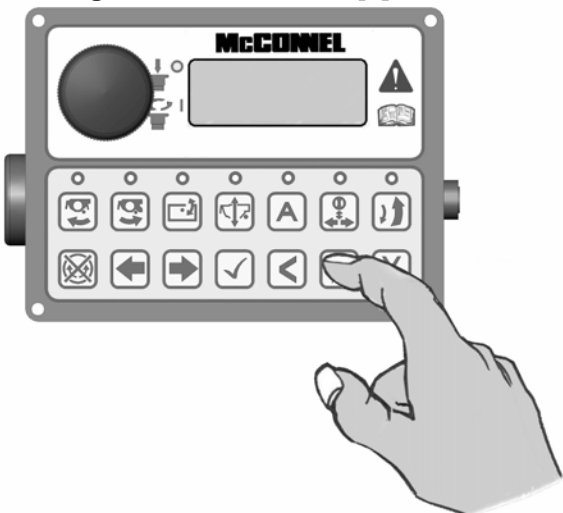

Navigate Back Button [<]

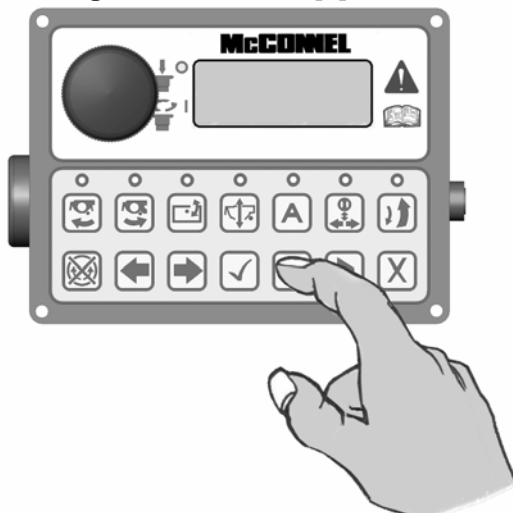

V4 CONTROL UNIT – LED Screen Display & Functions

IMPORTANT: Under no circumstances should a V4 Control Unit be connected to a V3 ACB (Auxiliary Control Box). Dedicated V3.5 & V4 Upgrade Kits are available from McConnell Limited – contact your local dealer or McConnell direct for available options and specific advice on this subject.

Rotate the ON/OFF switch on the control unit clockwise to power up controls - unit will emit a single beep and the LED screen will light up. *Note: 12 Volts at the battery is required for the unit to function correctly.*

1. Screen will initially display the 'McConnel' name along with the selected PTO speed and the software versions installed on the Armrest and the Control Box respectively.

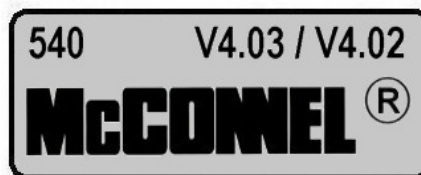

2. Pressing the scroll forward [▶] button once will display the rotor running times screen. 'TOT' displays the overall total running time of the rotor which is a cumulative total and cannot be reset. 'JOB' is a 'trip' total for the current rotor running time and can be reset to zero by pressing and holding the [X] button for 3 seconds.



3. Pressing either of the 'Rotor On' buttons will activate the 'egg timer' icon and display the rotor on image.



4. Pressing the EDS Lift float button will turn on the EDS (EDS Lift Float machines only). Then SOFT, MED or HARD will be added to the running screen.



5. Pressing the tick [✓] button when EDS is turned on will scroll through the EDS work settings of SOFT, MED or HARD. This may also be operated via button B1 on the joystick.

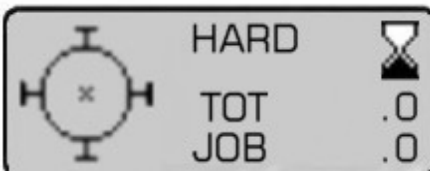

6. Pressing scroll forward [▶] button will now display the actual Tractor PTO running speed.



7. Scrolling forward [▶] again displays the Power Monitor screen.



Scrolling backwards [◀] will display the screens in the opposite order.

POWER MONITOR

When displayed the power screen will indicate to the operator the level of power being demanded by the cutting head – an ascending graphic indicates the power demand status from minimum on the left of the screen to maximum on the right.



Power Status – Low Demand



Power Status – High Demand

When the power demand approaches the maximum limit an audible warning will alert the operator to indicate that the rotor is under excess load and at risk of ‘stalling’ – when this audible warning sounds the operator should reduce the forward tractor speed to protect the machine and regain efficient cutting power – the audible warning will cease when the power demand returns to an acceptable level.

In certain cases, cutting materials of extreme density may cause an increase in the power usage to the ‘warning level’ – in these types of conditions raising the cutting head into a less dense area of the material will regain an acceptable power demand. It is advisable that work in problematic high density materials be performed in several passes, lowering the cutting head slightly on each pass until the required cut height is achieved.

ADDITIONAL CONTROL & SCREEN SETTINGS

Additional settings available to the operator can be found within the settings menu of the control unit and accessible via the screen and menu buttons on the control panel.

Access is gained by simultaneously pressing the scroll [◀] [▶] buttons on the control panel until the unit emits a ‘beep’ and the setup screen appears on the LCD - the features can then be ‘scrolled’ to (forwards or backwards) by subsequent operation of either of the scroll [◀] [▶] buttons. When the required screen is reached the tick [✓] button should be pressed to enter the settings menu for that feature.

THUMB (Thumbwheel Switching) – this allows the operator to ‘swap over’ the left and right thumbwheel functions so that they control the opposing features. In most cases this setting will be dictated by the operators’ personal preference and once chosen the operator will keep it in the selected mode.

Options are ‘Normal’ or ‘Swap’ – selection is by ‘highlighting’ the required option using either of the scroll [◀] [▶] buttons – the feature is then activated using the tick [✓] button. Pressing the [X] button exits the screen settings and returns to the normal work screen.

LED (Screen Contrast) - this setting allows the operator to adjust the contrast level of the LED display – the feature affords the option to increase or decrease the contrast level to suit differing lighting conditions; this is particularly useful on dull or sunny days where reduced or increased natural light can affect screen clarity.

Options are ‘Increase Contrast’ or ‘Decrease Contrast’ – selection is by ‘highlighting’ the required option using either of the scroll [◀] [▶] buttons – once selected that particular option can then be adjusted in incremental steps by pressing the tick [✓] button the required number of times to achieve the desired contrast. Pressing the [X] button exits the screen settings and returns to the normal work screen.

CAUTION: Avoid adjusting the contrast level to a state where the screen cannot be viewed as exiting the settings menu in this condition may render the LCD unusable as the ‘on screen’ prompts may no longer be visible to the user.

NOTE: Some screen menus are inaccessible to the operator – these are for factory or dealer use only and are password protected to avoid inadvertent changes to specific control settings.

TEST & FAULT FINDING SCREENS

The following screens are available for testing and fault finding purposes, these are:

JOYSTICK TEST SCREEN

This screen reports the status of the CAN (*Controller Area Network*) signal from the joystick during its various functions.

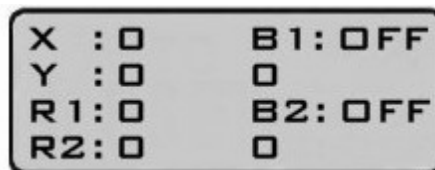

X and Y Display

These report the joystick signal as it travels through its range of movements in its 2 axis – the ‘X’ axis being the ‘Lift’ up and down function and the ‘Y’ axis the ‘Reach’ in and out function.

With the joystick in the central (*neutral*) position both ‘X’ and ‘Y’ on the screen should read 0 (*zero*). When the joystick is moved through a specific axis the relevant readout will increase or decrease depending on the direction and distance of movement up to a maximum of +1000 in the fully forward or fully right position and -1000 in the fully back or fully left position. If the display reports a reading above the + or – 1000 figure at any point of full travel the joystick has developed a fault and should be repaired or replaced.

R1 and R2 Display

These report the signals from the 2 thumbwheels on the top of the joystick and are calibrated to read +1000 in the fully back position and -1000 in the fully forward position. If either of the ‘R’ readings are above the + or – 1000 figure at the point of full travel the thumbwheel has developed a fault and should be repaired or replaced.

B1 and B2 Display

These report the status of the 2 joystick buttons and will display ‘ON’ when the button is activated or ‘OFF’ when deactivated. The readings below B1 and B2 on the screen record usage of the buttons.

EDS STATUS SCREEN

Although this screen is present on all v4 controls, with the exception of the voltage reading, the information it reports is only actually relevant to machines fitted with EDS.

In addition to the aforementioned voltage reading the screen will report Lift Ram Pressure and Reach Position status – in each case these will display ‘OK’ when the system is working correctly. If ‘FAULT’ is displayed next to one or other feature it means a problem has been detected with that component and it should be investigated further to locate and correct the problem.

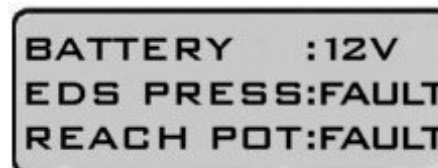
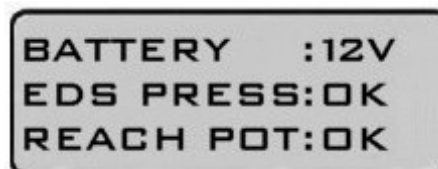

NOTE: As the pressure and position features are not present on Non EDS machines by default the screen will display ‘FAULT’ next to the features on these models – this is normal and should be ignored. The voltage reading will be relevant on all models.

REACH FUNCTION SCREEN

This screen displays the status of the joystick reach function and indicates to the operator if the controls are set for correct operation of the machine to the left hand side of the tractor or to the right hand side of the tractor. The hand symbol with a ✓ displayed on it indicates the operating side that is currently active.



L/H Machine Operation



R/H Machine Operation