

XTC PROPORTIONAL SWITCHBOX CONTROLS

Machines with XTC Proportional Controls will be supplied with the control unit shown below. The units for both electric and cable rotor machines are identical except that on cable versions the rotor control switches (D & E shown below) will not provide a function as rotor operation will be controlled by a separate cable lever unit (refer to specific cable rotor control page for operation information).



LOCATION & FUNCTION OF CONTROLS

- | | |
|--|--|
| 1. Arm Lift Control | A. Power On/Off |
| 2. Arm Reach Control | B. Auto Reset |
| 3. Flailhead Angle Control | C. Head Float - Angle/Lift (Option) |
| 4. Arm Slew Control | D. Rotor On/Off (Electric RCV models) |
| 5. Tele/Midcut Control (<i>Tele or Midcut models only</i>) | E. Rotor Direction (Electric RCV models) |

Powering the Controls

Activation of power to the control unit is by operation of switch 'A' as shown below:

Press the switch down for Power ON (LED light on)

Press the switch up for Power OFF (LED light off)



ARM OPERATION

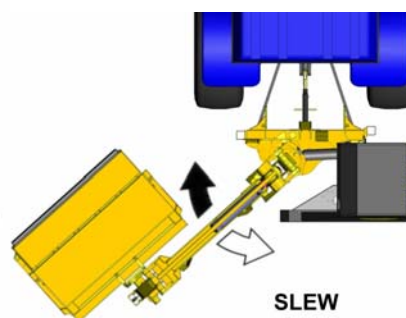
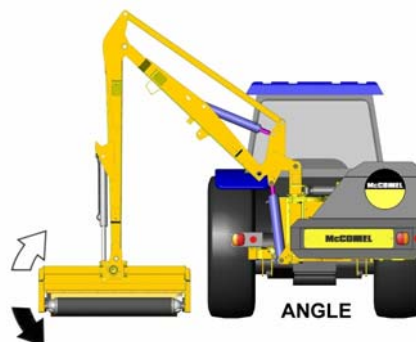
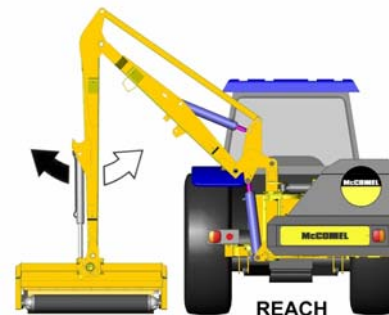
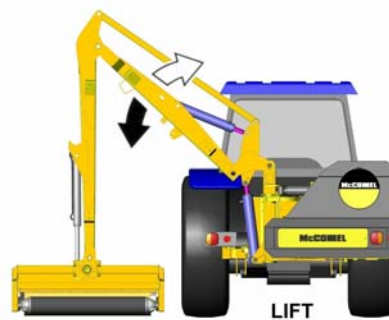

Tele or Midcut Models only

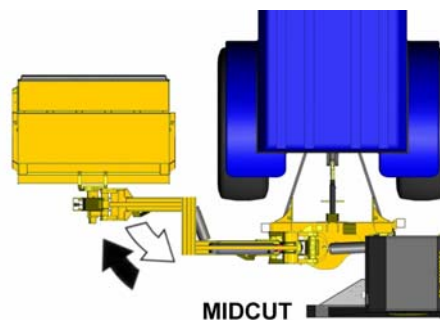
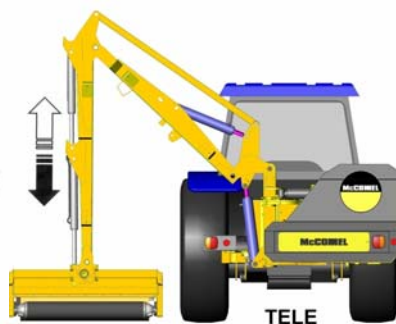

HEAD FLOAT OPERATION (Angle Float standard / Lift Float optional)

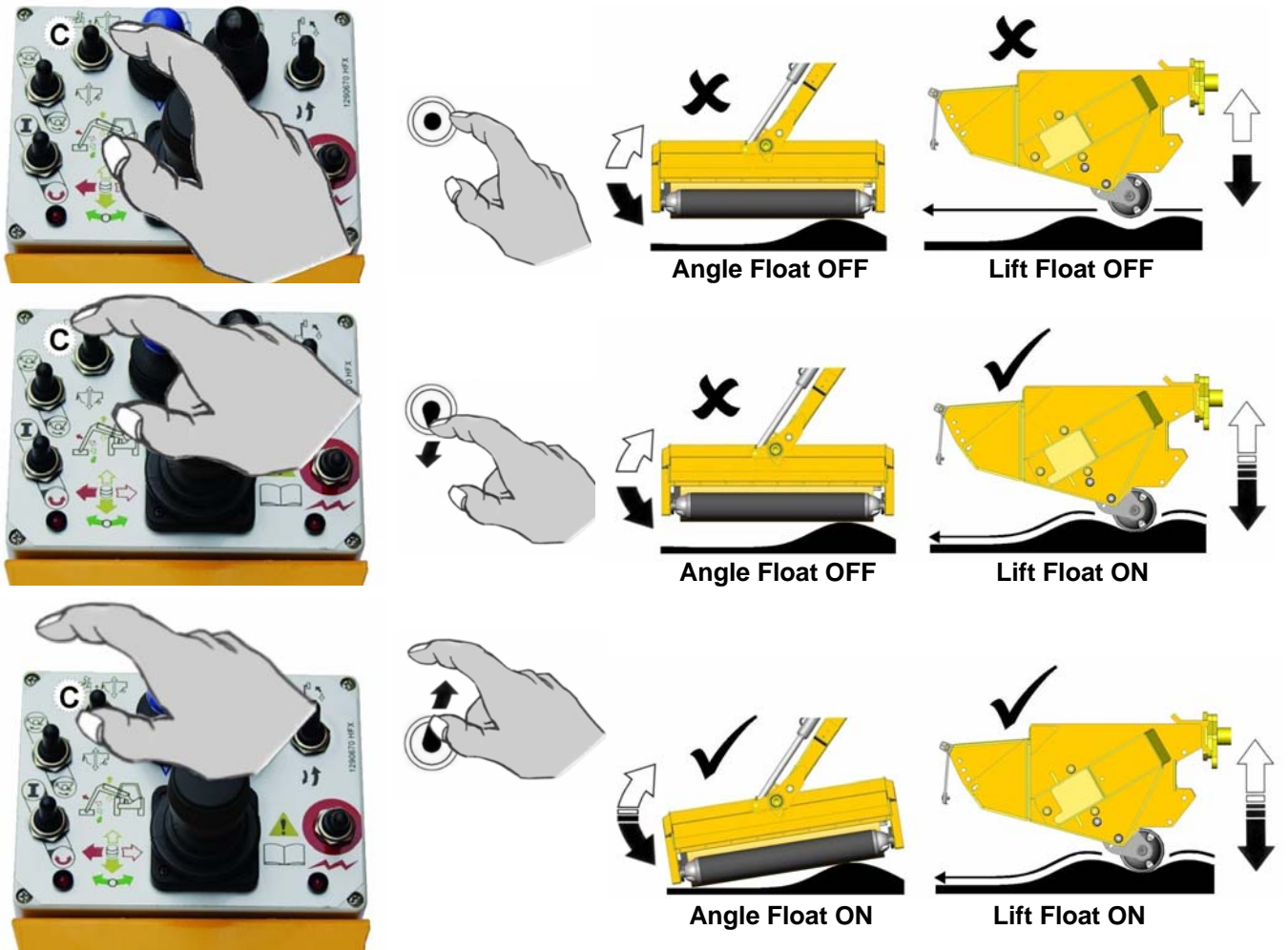

ROTOR OPERATION – Electric Rotor Control Models only

NOTE: The following section relates to machines with Electric Rotor Control only – for Cable Rotor Control models refer to the cable rotor control section.

Selection of Rotor Cutting Direction

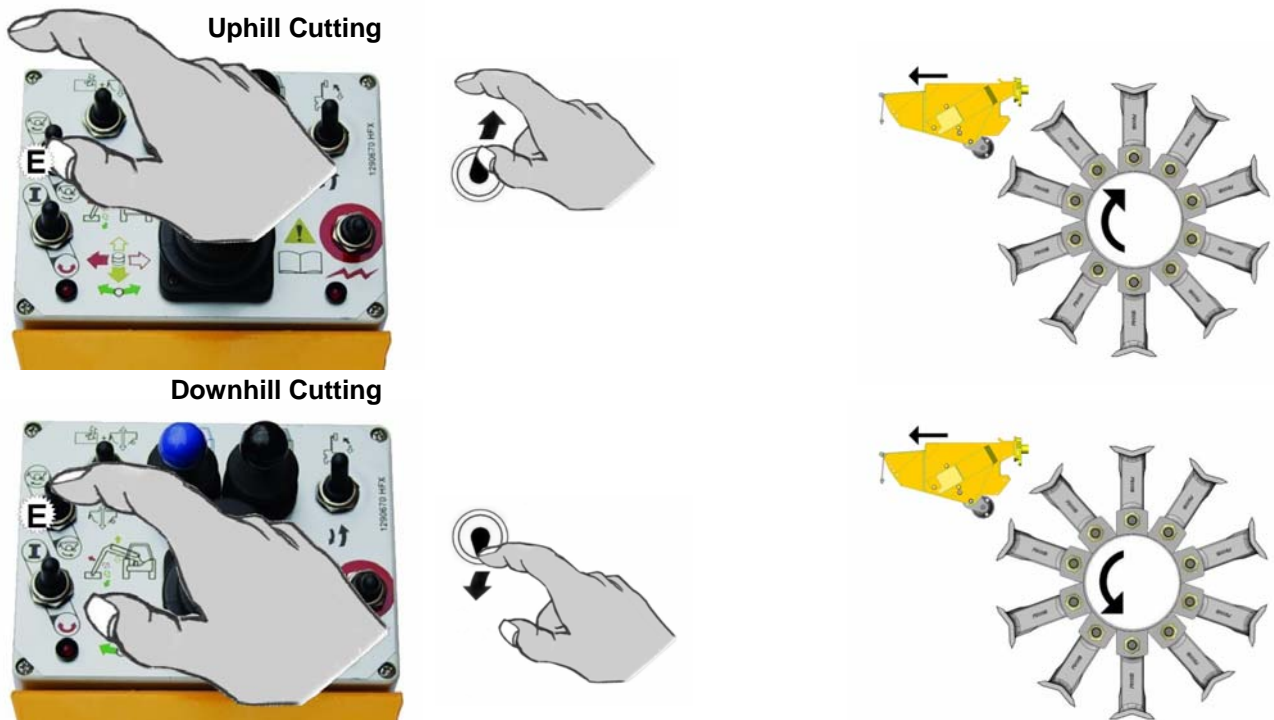

Switching the Rotor On

For safety reasons, to prevent accidental starting of the rotor, the 'Rotor On' switch cannot be activated in a single operation or without first selecting the direction of cut – the procedure for starting the rotor is as follows:

Select the required cutting direction - the Rotor On/Off Switch (D) must then be switched upwards and held in position for a minimum of 8 seconds before switching it into the fully down 'on' position where it will remain until it is switched off. When the switch is moved to the down position the red LED light below the switch will be lit to signify the rotor is on – if the LED does not light the switch was not held in its up position for long enough and the rotor will not have started, repeat the process again holding the switch upwards for a longer period.

Rotor Start

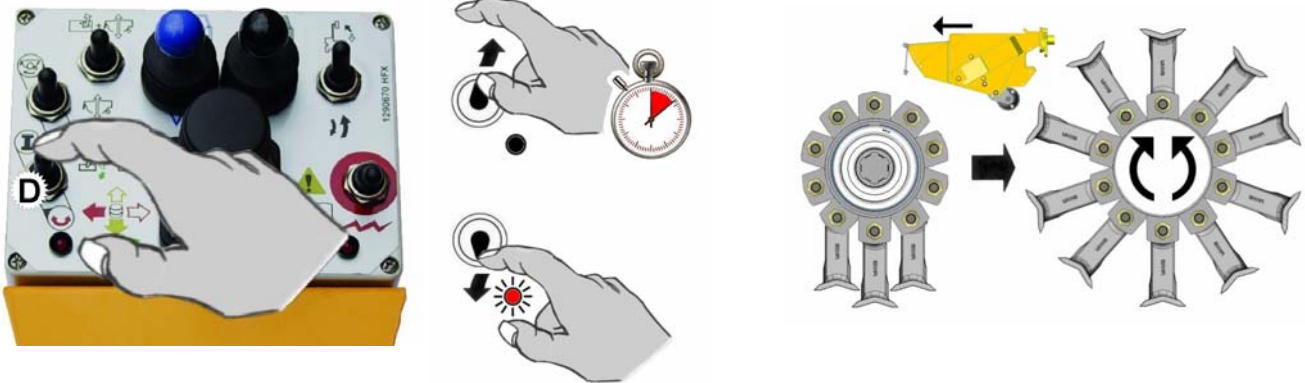

Switching the Rotor Off

Stopping the rotor is performed by switching either the Rotor Power Switch (D) or the Rotor Direction Switch (E) to the central (off) position – the red LED light will go out to signify the rotor has been switched off.



CAUTION: When the rotor is switched off it will continue to 'freewheel' under its own momentum for up to 40 seconds before finally coming to a standstill – do not leave the tractor cab or attempt to approach the flailhead until the rotor has stopped turning completely.

Rotor Stop

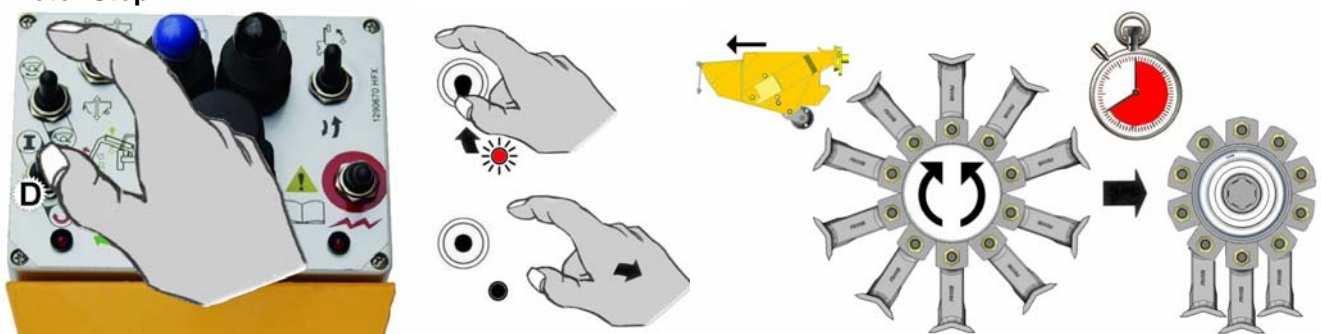

Alternative Rotor Stop

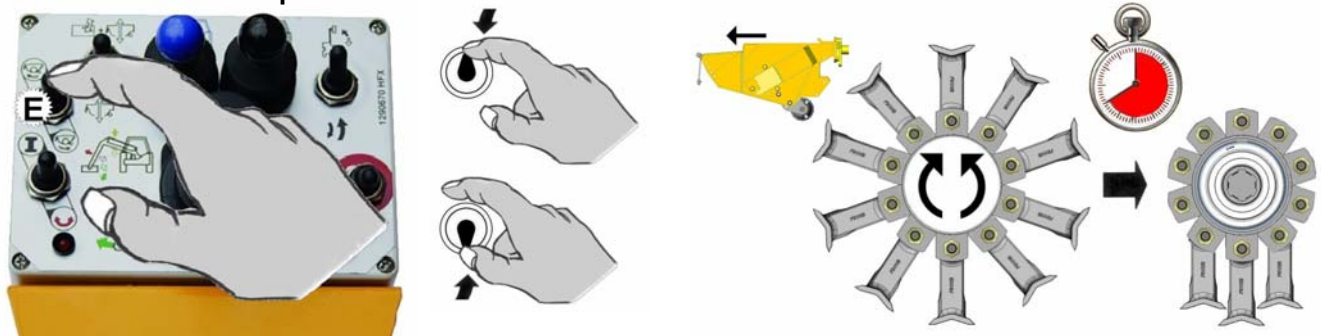

CABLE ROTOR CONTROL

On cable rotor control machines the rotor is operated by the lever shown below – from the upright 'off' position pushing the lever forward switches the rotor on for downhill cutting and pulling the lever backwards switches the rotor on for uphill cutting. The small pivot locking lever mounted on the side of the control assembly rotates through 180° to lock the rotor in a specific cutting direction – this is a safety feature to avoid changes of rotor direction without first stopping the rotor. To change the direction of cut the rotor lever must be placed in the upright 'off' position; when the rotor has stopped rotating completely the pivot locking lever can be turned to the opposing position allowing the control lever to be operated for opposite cutting direction.

On some cable operated machines the rotor control lever will be assembled as part of the main bank of controls, whereas on others and all electric models it will be supplied as a 'standalone' unit with its own mounting bracket.

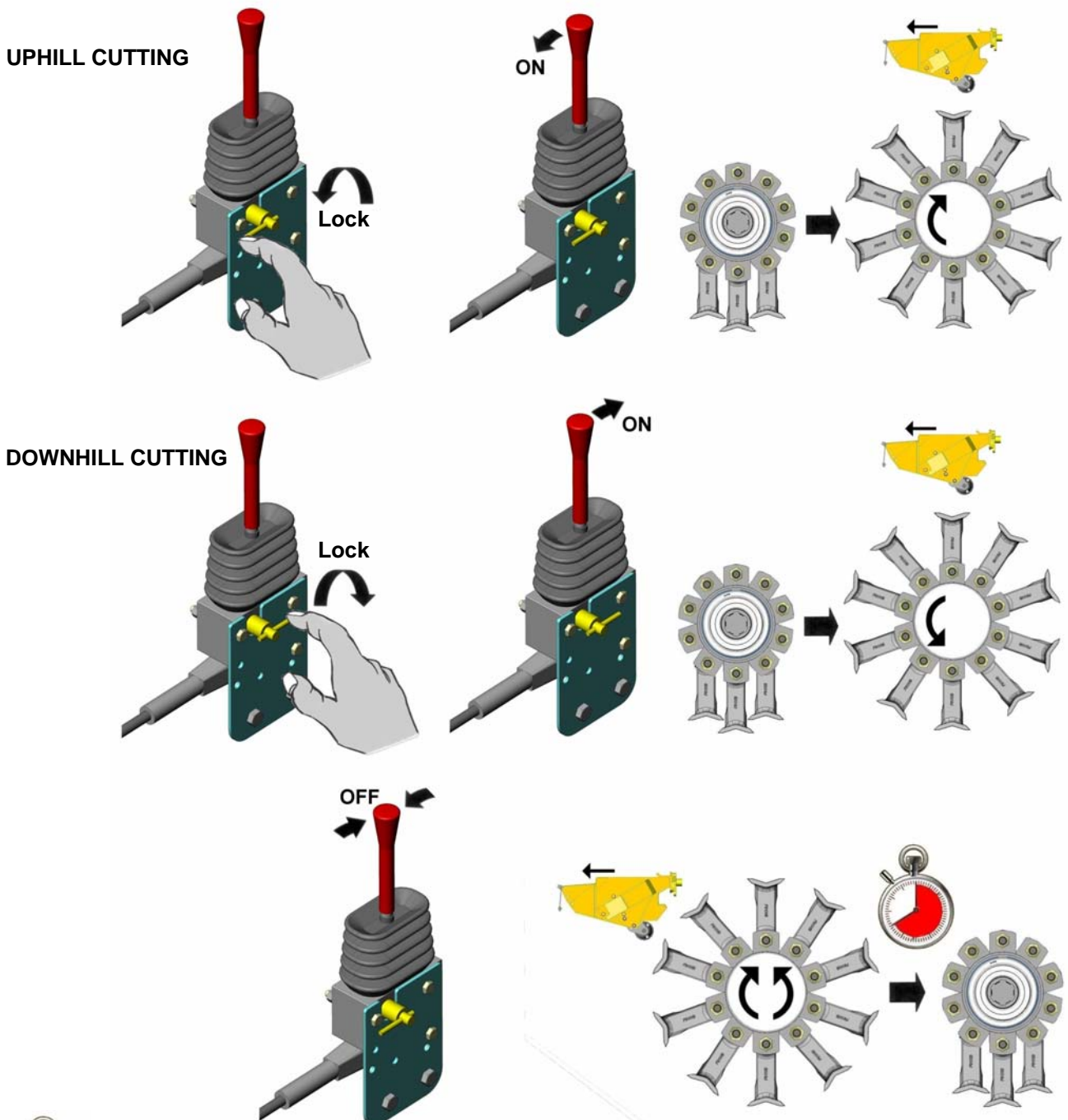

CAUTION: Ensure the rotor has stopped turning completely before attempting to change direction - When switched off a rotor can continue to 'freewheel' under its own momentum for up to 40 seconds before stopping.