

## XTC (Mk2) PROPORTIONAL SWITCHBOX CONTROLS (5 Service Models)

Machines with XTC Mk2 Proportional Controls (5 service models) will be supplied with the control unit shown below. The units for both electric and cable controlled rotor machines are identical except that for cable versions the rotor control switches B, C & D (shown below) will not provide a function as rotor operation will be controlled by a separate cable lever unit (refer to specific cable rotor control page for operation details of that unit).

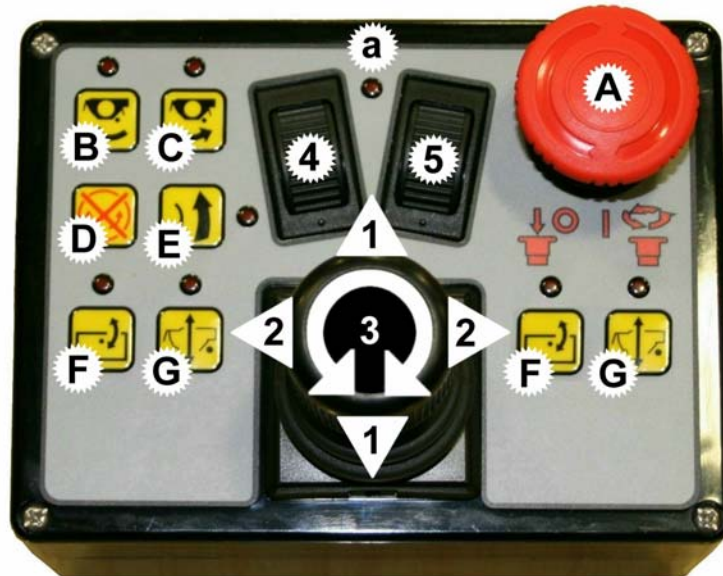

### LOCATION & FUNCTION OF CONTROLS

- |  |   |
|--|---|
| 1. Arm Lift Control                          | A. Power On/Off (LED 'a' indicates status)  |
| 2. Arm Reach Control                         | B. Rotor Start (Uphill Cutting Direction)   |
| 3. Head Angle Control                        | C. Rotor Start (Downhill Cutting Direction) |
| 4. Arm Slew Control (Default Mode)           | D. Rotor Stop                               |
| 5. Tele*/Midcut*/VFR* Control (Default Mode) | E. Auto Reset                               |
|  | F. Head Angle Float On/Off                  |
|  | G. Lift Float On/Off (Option)               |

\* Applies to the specific model only

Note: 2 sets of control buttons are installed on each side of the unit for operation of Angle Float & Lift Float; both sets of buttons and their LED's are linked and therefore perform exactly the same function; they are installed to allow for operator preference.

### LED Lights

An LED light adjacent to each control button reports the status of that particular function – when the function is selected the LED light will illuminate to confirm the function is active; the light will switch off on de-selection of that function.

### Powering the Controls

Activation of power to the control unit is by operation of the red button switch 'A' as shown below:

**Rotate** clockwise for **Power ON** (LED light on)

**Press** for **Power OFF / Emergency Stop** (LED light off)

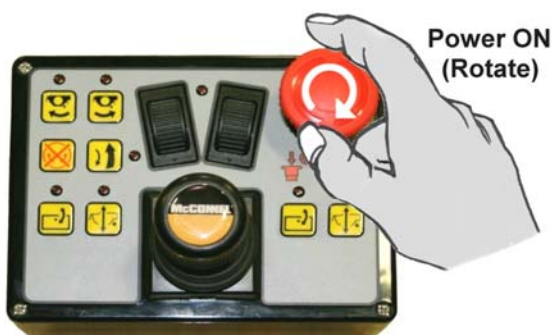

# ARM OPERATION

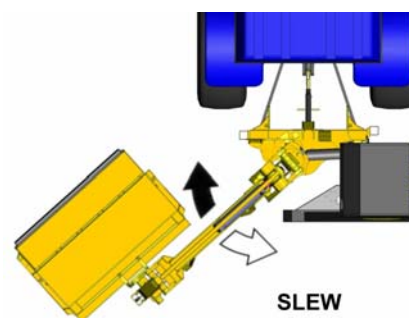
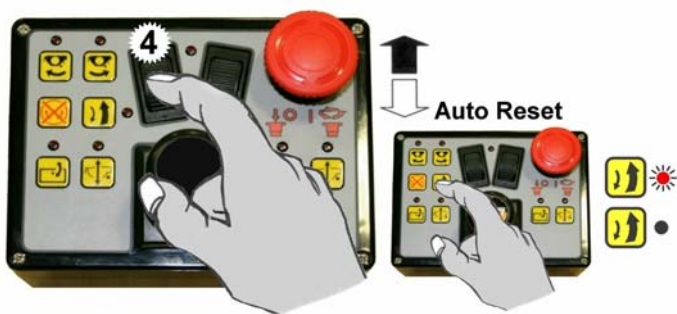
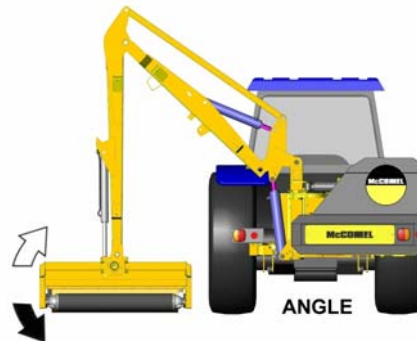
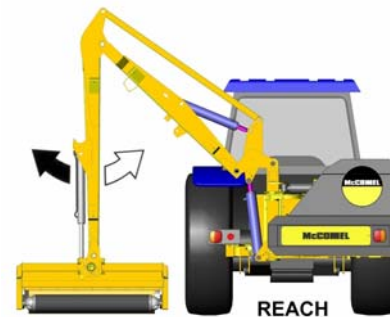
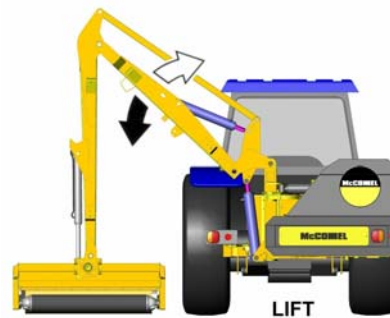

Tele or Midcut/VFR Models only

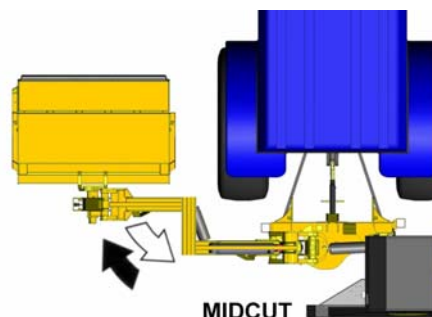
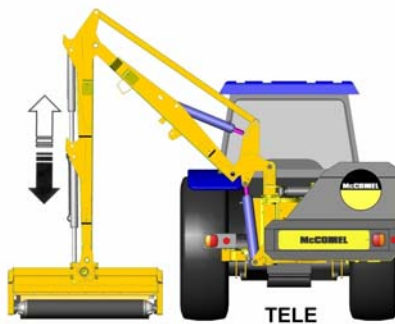

# HEAD FLOAT OPERATION

## Angle Float (Standard Feature)

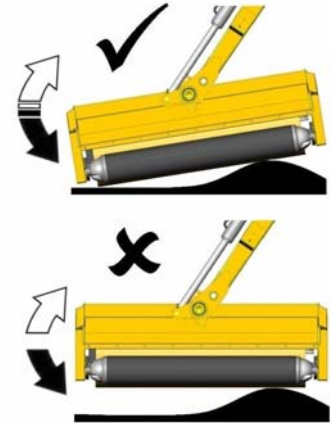

## Lift Float (Optional Feature)

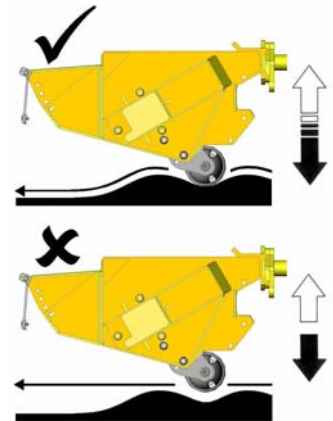

# ROTOR OPERATION – Electric Rotor Control Models only

**NOTE:** The following section relates to machines with electric rotor control only – for cable rotor control models refer to the specific cable rotor control section.

## Rotor Start (Selection of Rotor Cutting Direction)

Select rotor start for required direction (LED will light to indicate the active direction).

### Uphill Cutting

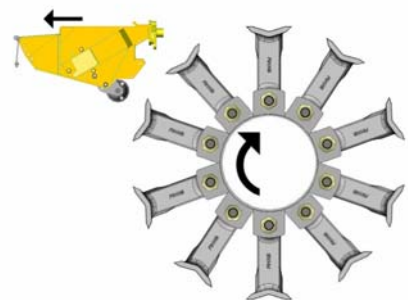

### Downhill Cutting

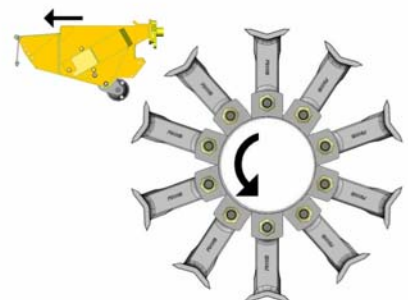

## Switching Rotor Direction

With the rotor running, changing the rotor cutting direction can only be achieved after first operating 'rotor stop', when stop has been selected the specific direction button can then be operated to command the rotor to switch to the desired direction. NOTE: This function has a built in time delay of approximately 8 seconds - this is a machine protection feature that allows the rotor sufficient time to de-accelerate before restarting in the opposite direction. The LED light of the active cutting direction will flash on and off during the slowing down period, when the direction has changed the LED for the new direction will be illuminated.

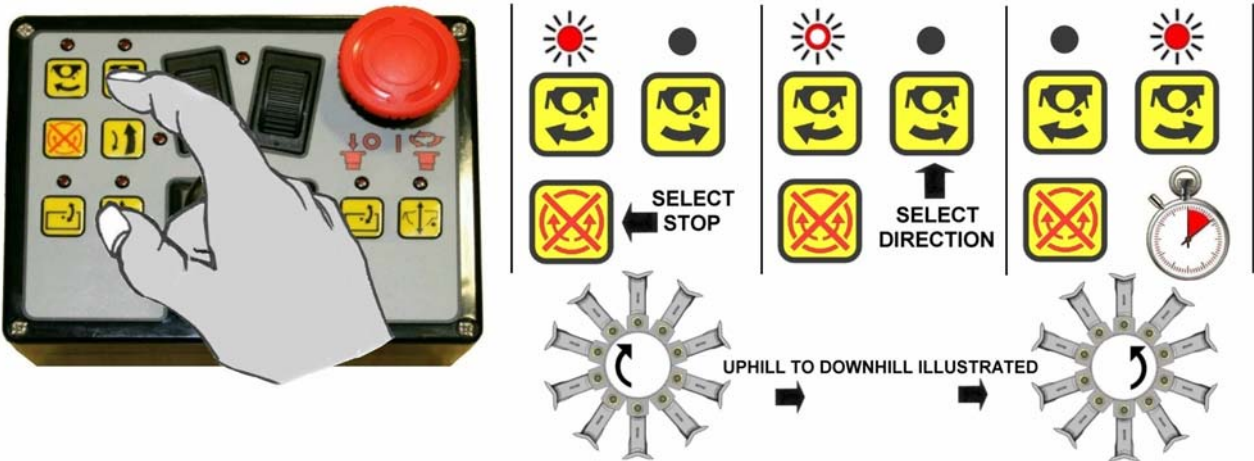

## Switching the Rotor Off

Stopping the rotor is performed by operation of the rotor stop button as illustrated below. When rotor off has been selected the LED light above the button of the active cutting direction will flash on and off for approximately 8 seconds to signify that the rotor has been switched off, after this 8 second period the light will go off completely. NOTE: The rotor will continue to rotate under its own power until it finally comes to a standstill.

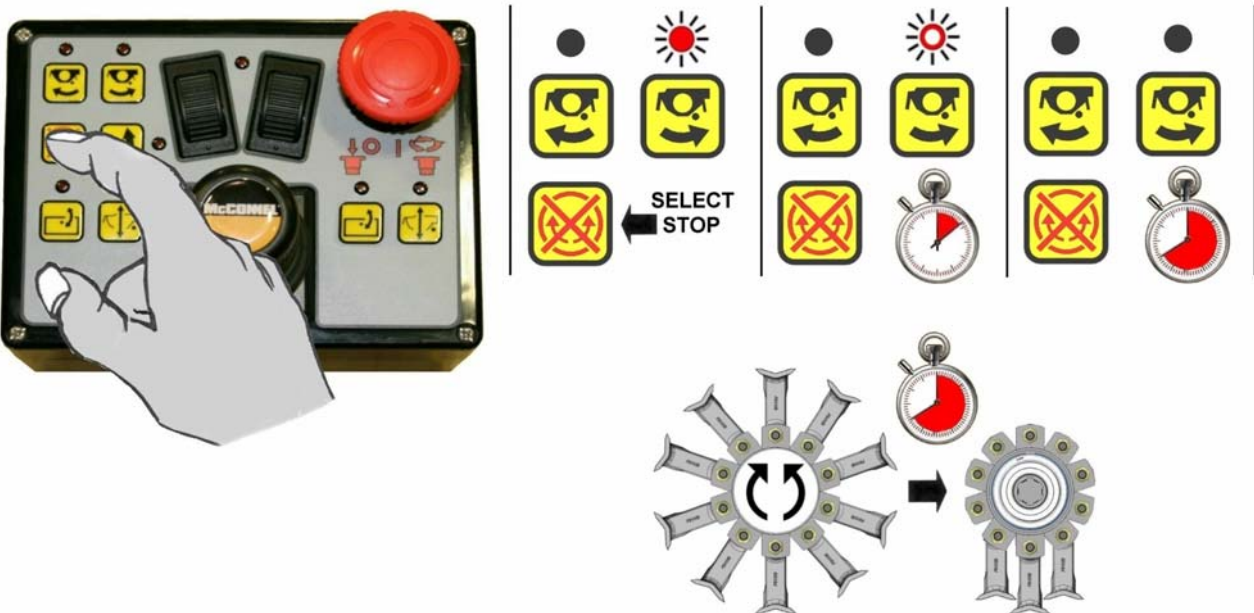

**CAUTION:** When the rotor is switched off it will continue to 'freewheel' under its own momentum for up to 40 seconds before finally coming to a standstill – do not leave the tractor cab or attempt to approach the flailhead until the rotor has stopped turning completely.