

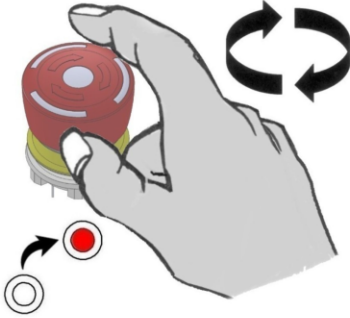

MINI MOTION CONTROL  
Gebruikershandboek  
VERSI machines

# MINI MOTION CONTROLS – VERSI Machines

Voeding AAN



Voeding UIT / NOODSTOP

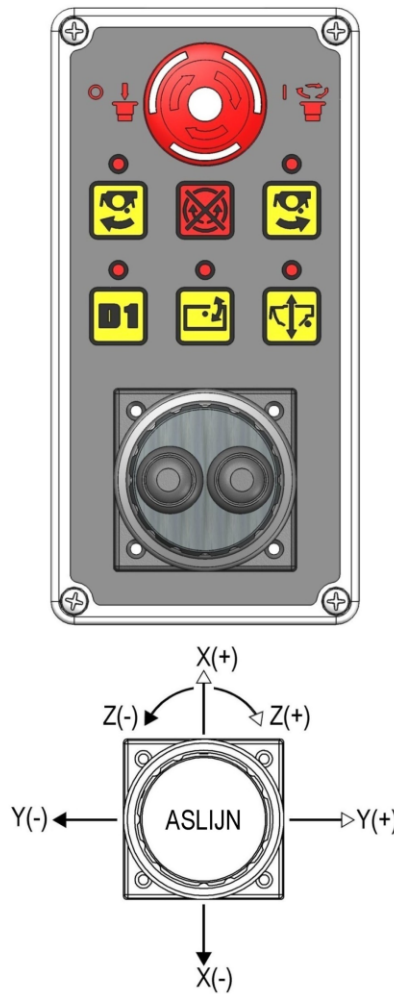
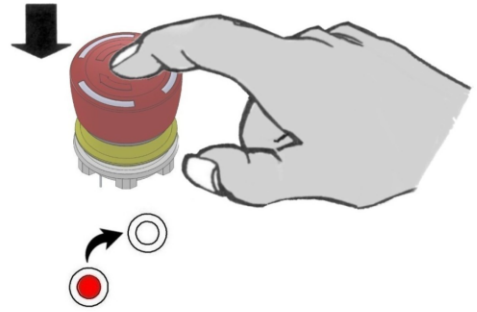

Default Besturingen  
 X Aslijn: Heffen operatie  
 Y Aslijn: Reikwijdte operatie  
 Z Aslijn: Hoek operatie  
 B1+Z Aslijn: Zwenk operatie  
 B1+Y Aslijn: 5<sup>e</sup>-functie

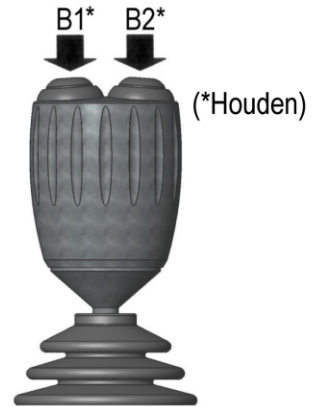

Voeding ANN Toetsen (NOODSTOP)

Rotor START (hellingopwaarts)

Wisselklep 6<sup>e</sup> Service-activering

Joystick

Joystick Toetsen #1

Power LED

Rotor START (hellingneerwaarts)

Rotor STOP

Zweefstand arm

Zweefstand maairotor

LED's : Functiestatus

○ Gedeactiveerd

● Actief

⊗ Tijdelijk gedeactiveerd



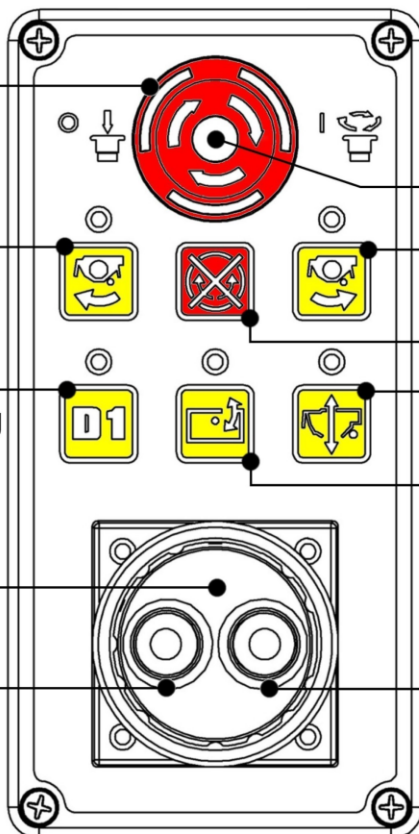



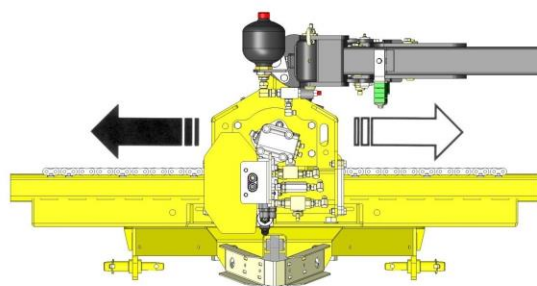
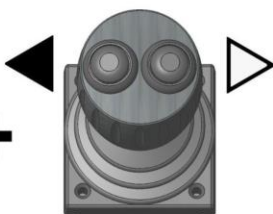
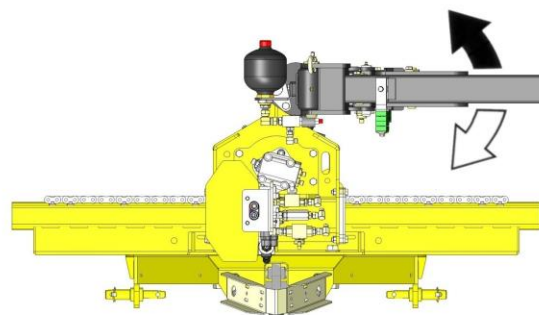
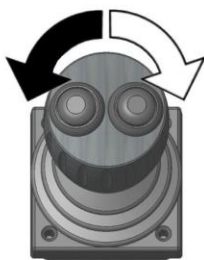
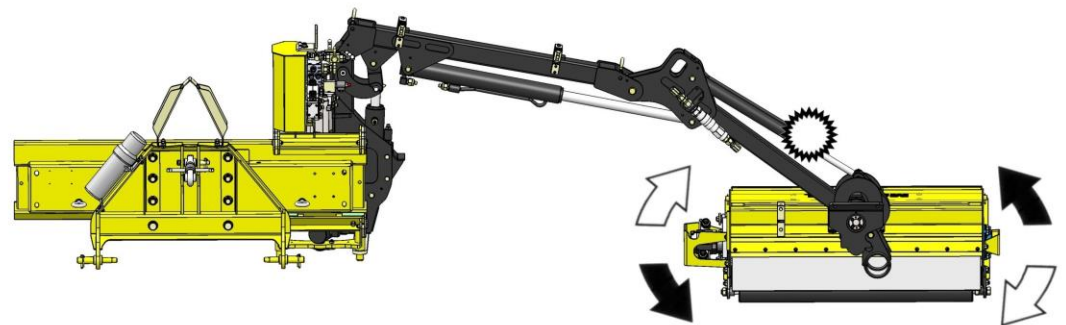
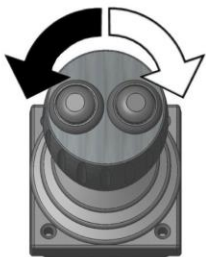
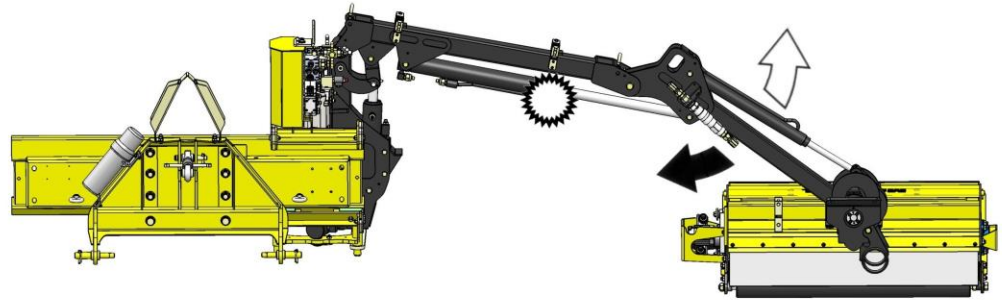
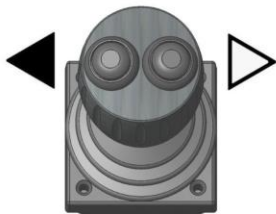
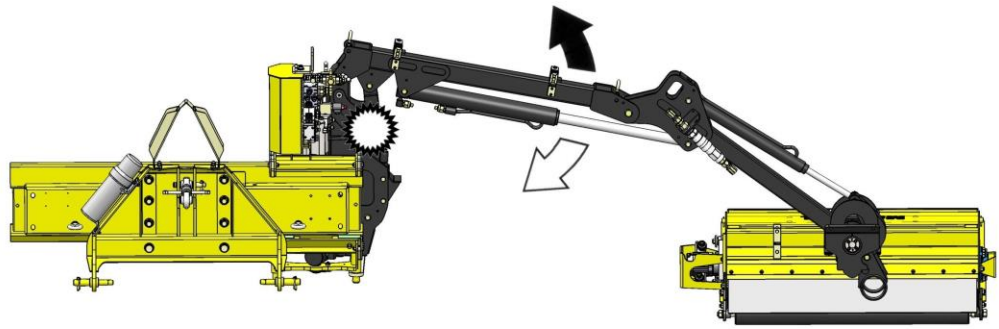

Joystick Toetsen #2



# Arm Working Controls



## Toetsenbord-besturingstoetsen

Button	Function	Control Operation
	Zweefstand maairotor AAN/UIT	Indrukken van toets zal de functie Zweefstand maairotor AAN/UIT zetten.
	Zweefstand arm AAN/UIT	Indrukken van toets zal de functie Zweefstand arm AAN/UIT zetten.
	Rotor START (maairichting hellingopwaarts)	Druk om de rotor te starten. <i>8 seconden vertraging voor richtingverandering.</i>
	Rotor START (maairichting hellingneerwaarts)	Druk om de rotor te starten. <i>8 seconden vertraging voor richtingverandering.</i>
	Rotor STOP	Druk om de rotor te stoppen. <i>Druk eerst voordat de richting wordt veranderd.</i>
	Wisselklep: 6 <sup>e</sup> Service-activering	Druk om de 6e Service AAN of UIT te schakelen.
	Funciestatus - UIT.	LED-lampje voor specifieke besturing UIT.
	Funciestatus - AAN.	LED-lampje voor specifieke besturing AAN.
	Funciestatus - Tijdelijk gedeactiveerd.	LED-lampje voor specifieke besturing KNIPPEREND.

# FLOAT WERKING

## Zweefstand maairotor AAN/UIT

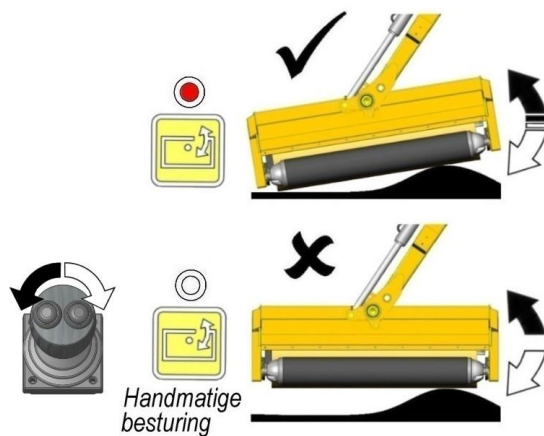
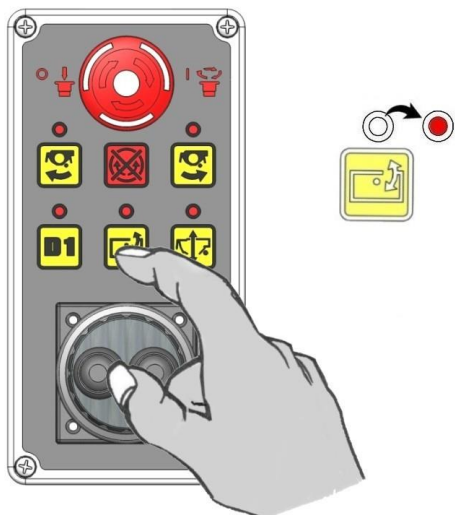

## Zweefstand arm AAN/UIT

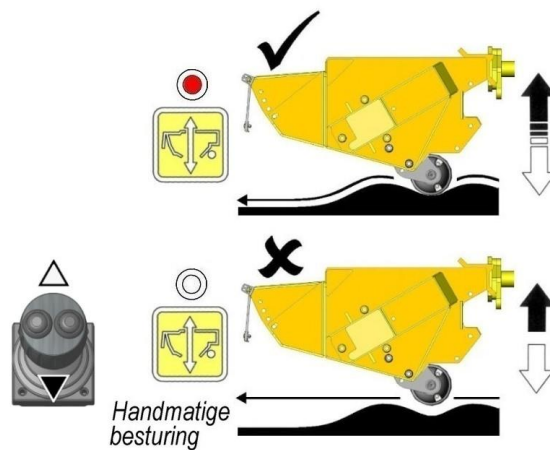
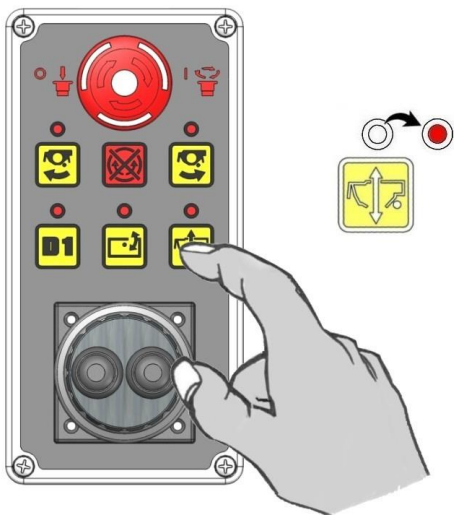



# ROTORBEDIENING

## Rotor Start - maairichting hellingopwaarts

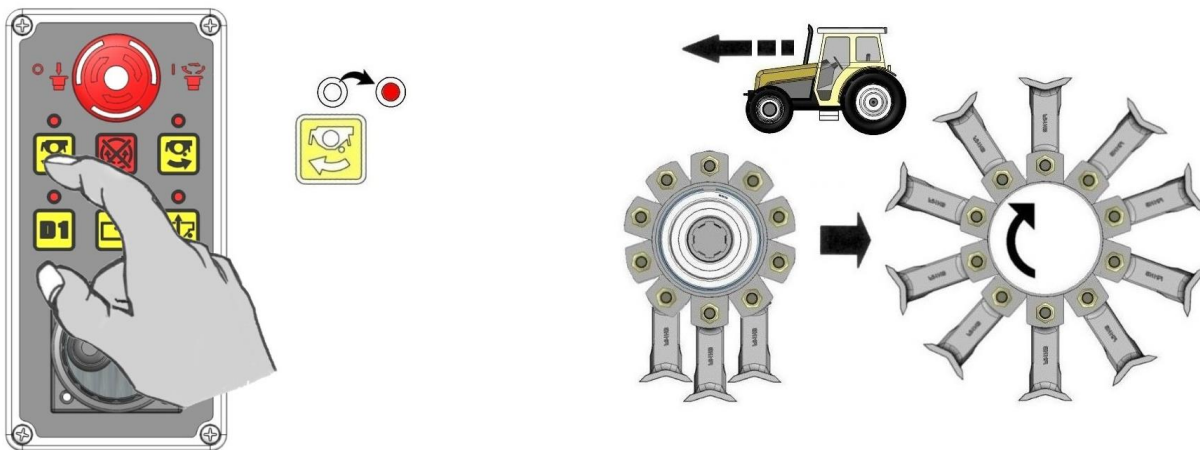

## Rotor Start - maairichting hellingneerwaarts

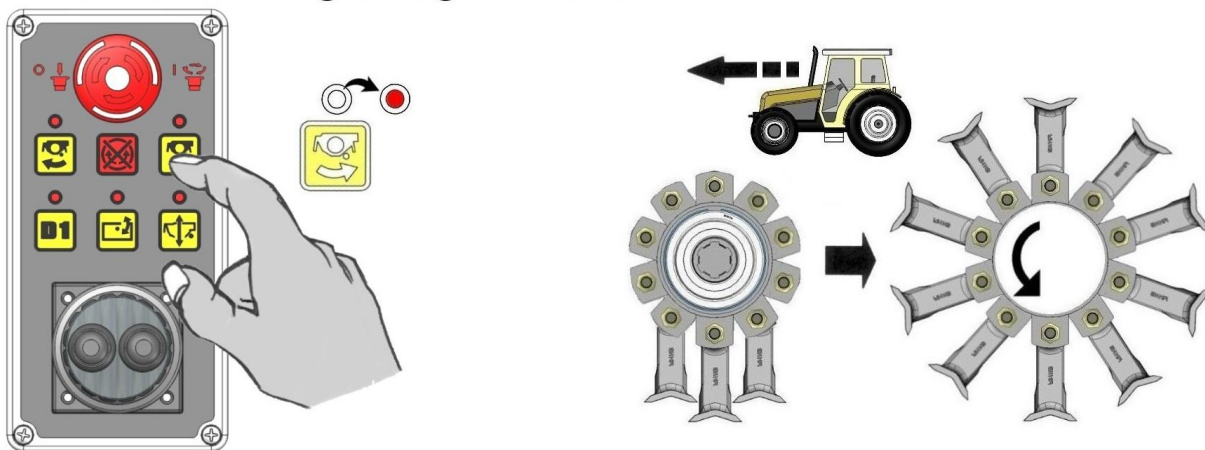

## Rotor Stop (hellingopwaarts of hellingneerwaarts)

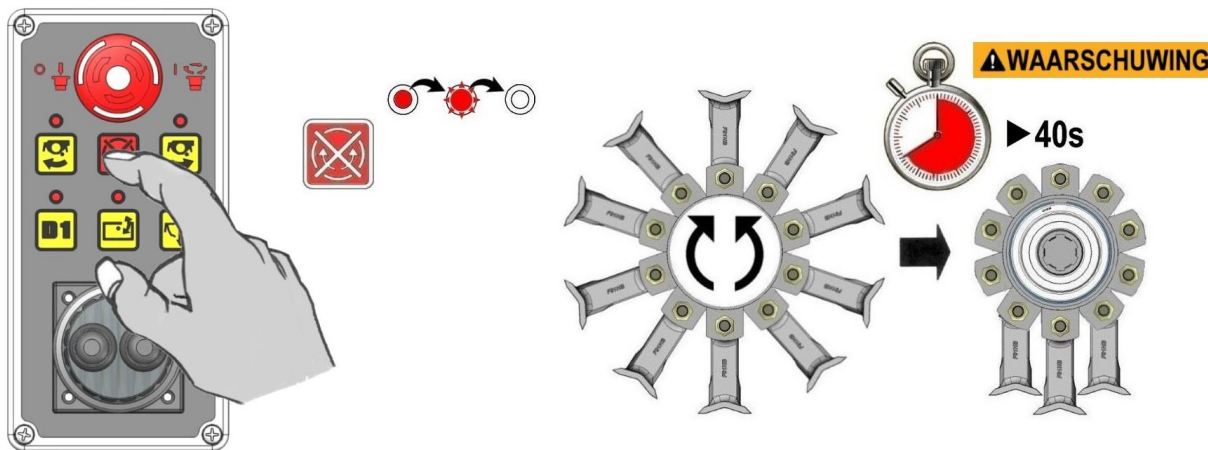

## **WAARSCHUWING**



Wanneer de rotor wordt uitgeschakeld zal hij onder zijn eigen momentum gedurende maximaal 40 seconden blijven 'freewheelen' voordat hij eindelijk tot stilstand komt - verlaat de cabine niet en probeer niet om de klepelkop te naderen tot de rotor helemaal stil staat.





McConnel Limited, Temeside Works, Ludlow, Shropshire SY8 1JL. England.  
Telephone: 01584 873131. Facsimile: 01584 876463. [www.mcconnel.com](http://www.mcconnel.com)