



EVOLUTION CONTROLS

Operation Manual



EVOLUTION CONTROLS



Thumb Wheels & Frontal Buttons

Rear Buttons

Default Control: TW1: Slew Operation B1: Slew ↻ Tele* Swap
 TW2: Angle Operation B2: Angle Float ON/OFF
 (Tele* / Midcut* / VFR* as applicable)

B3: Lift Float ON/OFF
 B4: Rotor STOP

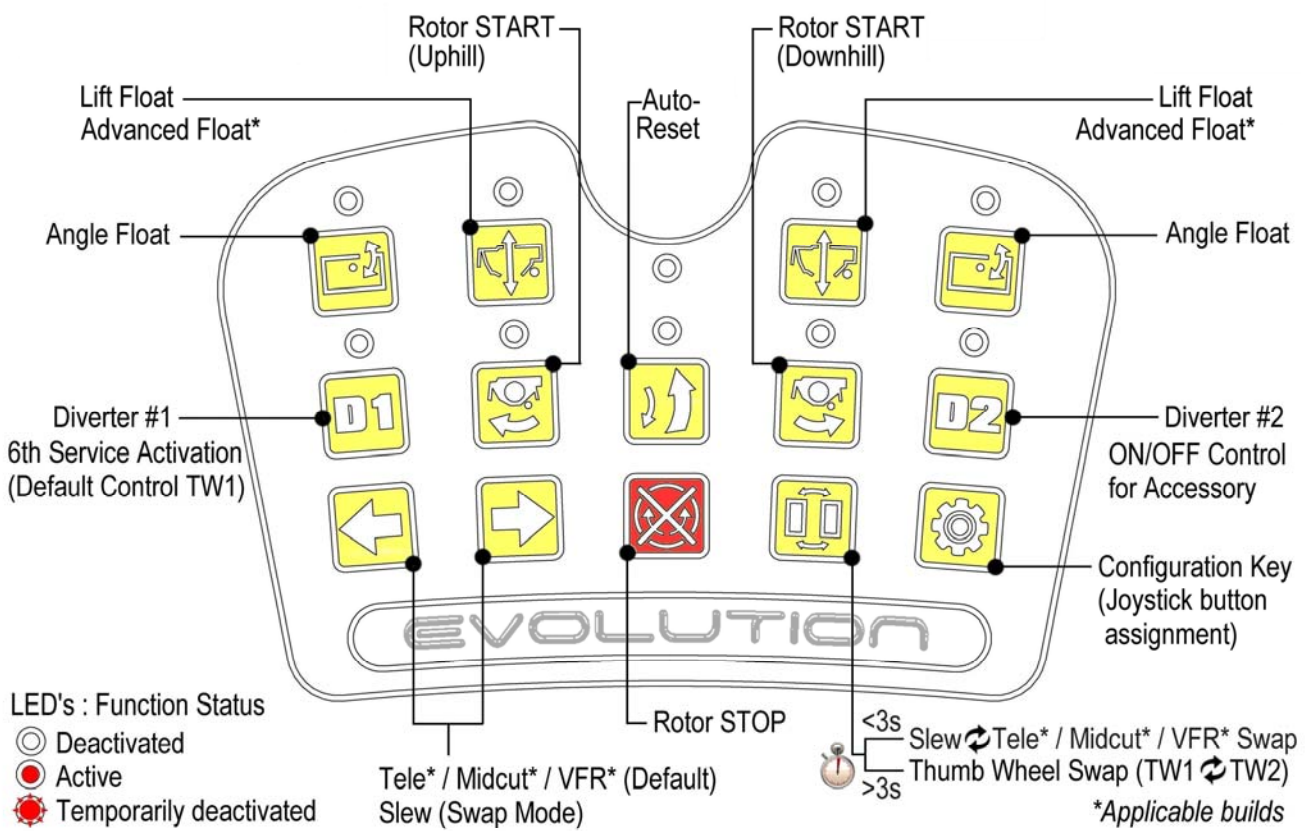





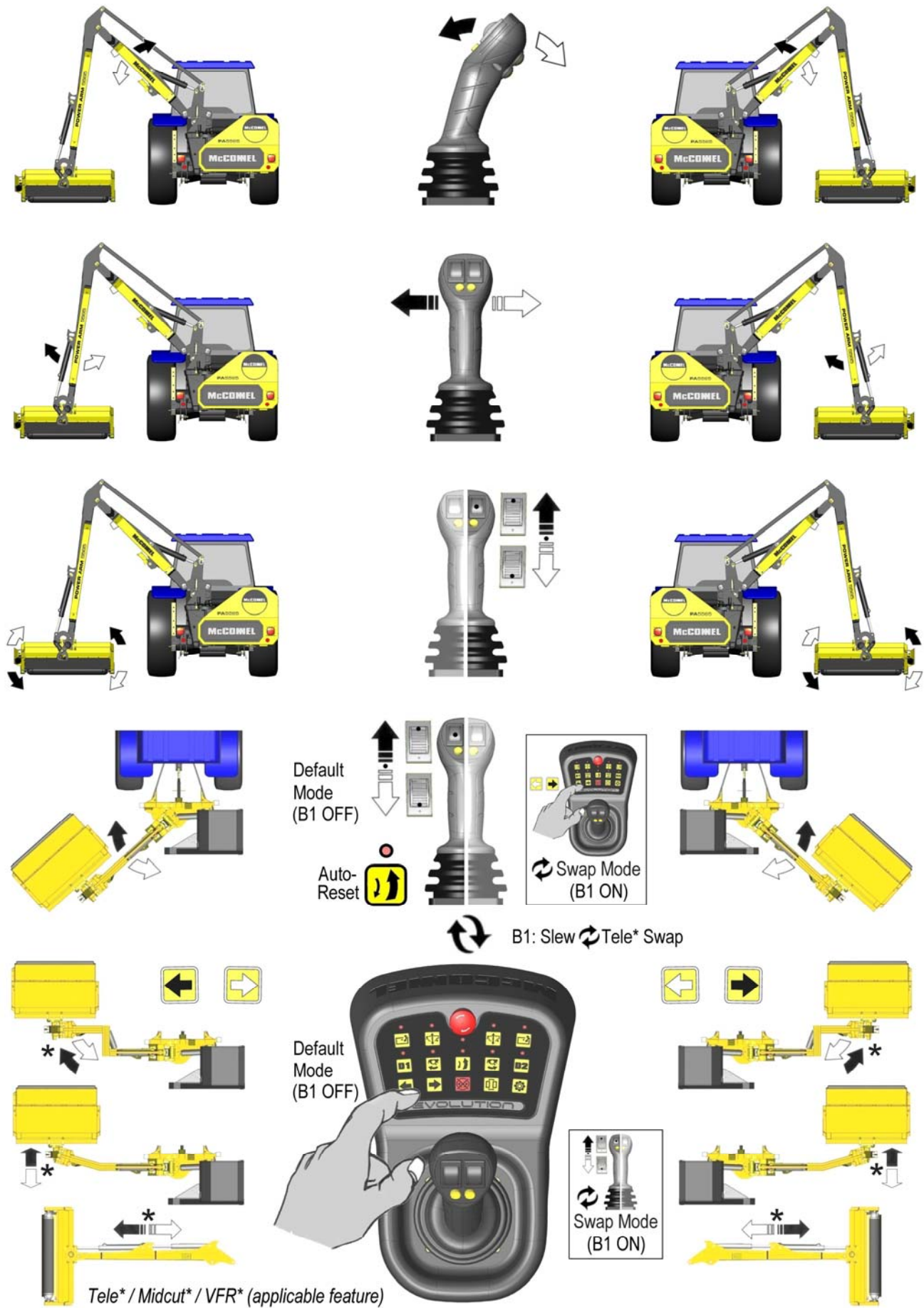







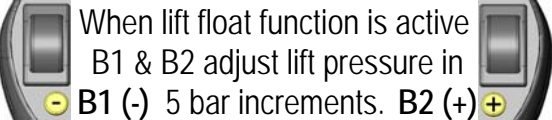







i On Tele/VFR machines, VFR is the default 'Slew Swap' function; the Tele function is configured to the D1 diverter control.

Arm Operation Controls



Keypad Control Buttons

Button	Function	Control Operation
	Angle Float ON/OFF	Pressing either the LH or the RH button will switch Angle Float function ON/OFF.
	Lift Float ON/OFF – <i>where applicable incl. Advanced Lift Float if feature is activated – latest status/setting is retained in memory.</i>	Pressing either the LH or the RH button will switch Lift Float function ON/OFF.
	Advanced Lift Float* Activate/Deactivate (* <i>where applicable</i>)	Press/hold buttons B1 & B2 for 5 seconds to activate Advanced Lift Float - repeat to deactivate the Advanced Lift Float feature.
	Advanced Lift Float; Lift Float pressure balance adjustment (± 5 bar increments).	 When lift float function is active B1 & B2 adjust lift pressure in B1 (-) 5 bar increments. B2 (+)
	Rotor START (Uphill Direction).	Press to start rotor. 8 second delay for direction change.
	Rotor START (Downhill Direction).	Press to start rotor. 8 second delay for direction change.
	Rotor STOP.	Press to stop rotor. Press first before direction change.
	Auto-Reset (Slew).	Press to activate auto-reset function. <i>Deactivates if slew is manually operated.</i>
 	Tele* / Midcut* / VFR* operation; <i>Default controls for the machines specific* function.</i>	Pressing the arrow buttons will operate the specific arm* function in the applicable direction. <i>Operates slew in swap mode.</i>
	A) Slew  Tele* Swap (* <i>specific function</i>) B) Thumb Wheel Swap (TW1  TW2)	A) Press button for less than 3 seconds B) Press button for more than 3 seconds
	Diverter #1 : 6 th Service Activation	Press button to activate 6 th Service. Operation is with Thumb Wheel 1 (TW1)
	Diverter #2 : Accessory Control ON/OFF	Press to switch the accessory ON or OFF. <i>Only applicable if an accessory is fitted.</i>
	Configuration Setting for Joystick buttons. <i>Options; Auto-reset, Angle Float, Lift Float, Rotor Stop, Slew-Tele Swap, D1, D2.</i>	Press and hold until continual beep, press the required joystick button then select the desired function on control unit keypad.
 Function OFF status (LED OFF).	 Function temporarily deactivated (LED Flashes).	
 Function ON status (LED ON).	 Calibration mode active (All LED's Flashing).	

Angle Float ON/OFF



Lift Float ON/OFF

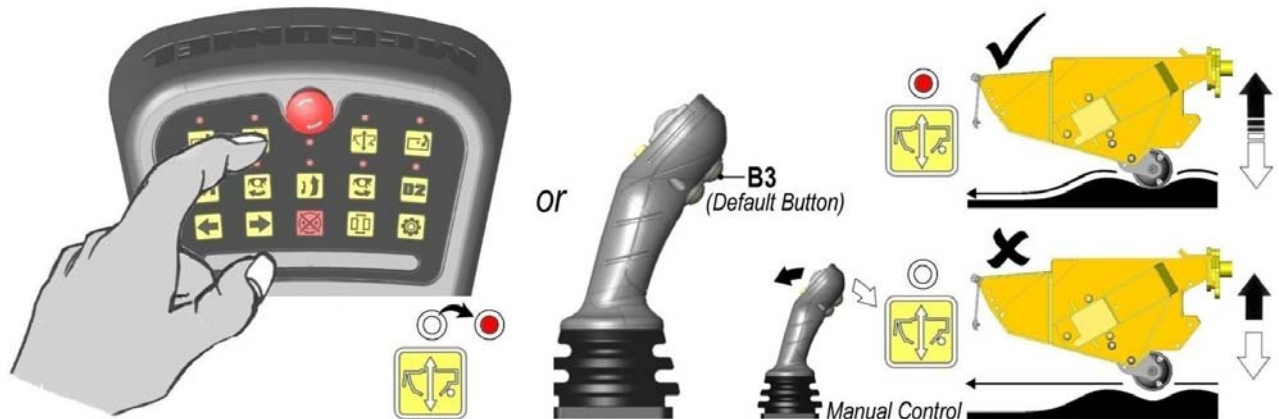

Advanced Lift Float *(Applicable builds only)*

On machines that feature 'advanced float' the feature is activated and deactivated by simultaneously pressing and holding buttons B1 & B2 for 5 seconds; the unit will then 'beep' to confirm the selection.

Lift Float Button LED Status;
 LED OFF: Lift Float OFF
 LED ON: Lift Float ON
 LED Flashing: Advanced Lift Float 'Active' (ON)

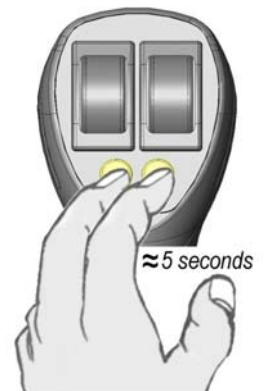

Advanced Lift Float;
ON / OFF Selection

Advanced Lift Float – Pressure Adjustment



Advanced Lift Float;
Pressure Adjustment

When advanced lift float is active, operation of joystick buttons B1 and B2 adjust the lift float pressure; B1 reduces the pressure and B2 increases the pressure; *each ± adjustment equates to a 5 bar pressure increment.*

NOTE: If the lift float setting is adjusted too low the unit will emit a series of 'beeps' and the arm will slowly rise and stop for 2 seconds before then returning to the ground; at this point lift float pressure will be reset to its default setting - *this is a built in safety feature for protection of machine and tractor components.*

Switching the advanced lift float function off and back on will recalibrate the system to its default pressure setting; this should be performed with the flail head raised clear of the ground (approx. 30cm).

ROTOR OPERATION

Rotor Start - Uphill Cutting

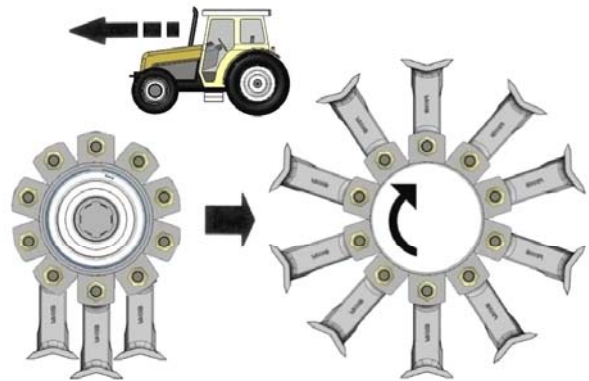

Rotor Start - Downhill Cutting

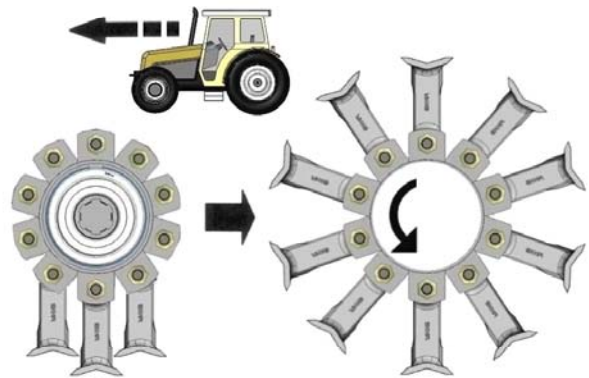

Rotor Stop (Uphill or Downhill)

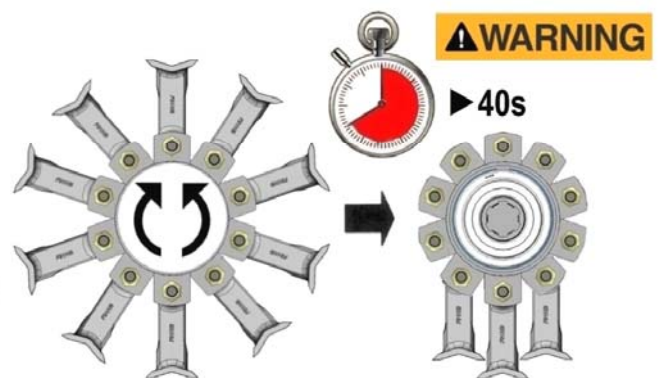

⚠ WARNING



When the rotor is switched off it will continue to 'freewheel' under its own momentum for up to 40 seconds before finally coming to a standstill – do not leave the tractor cab or attempt to approach the flailhead until the rotor has stopped turning completely.

TEMPERATURE COMPENSATION – SELECTION & CALIBRATION

The control unit features a built in temperature compensation system which automatically adjusts the performance of the system in response to increased solenoid temperatures ensuring maximum operating performance is retained in all work conditions.

On initial machine setup the temperature compensation system must be calibrated and activated; when this has been performed the temperature compensation system will not require any further attention or adjustment and will operate automatically.

*The procedures for calibration and activation of the temperature compensation system are as stated below. **Ensure PTO is OFF for the calibration procedure.***

Temperature Compensation - Calibration

With the control unit powered OFF;

1. Press and hold 'D1' & 'D2' keys.
2. Turn 'Power ON'; unit will emit a 'beep', **Power, D1 & D2 LED's will illuminate.**
3. Press 'Rotor Stop' key.
4. **D1 & D2 LED's will flash** (cutoff outputs will turn on for approx 2 seconds).
Unit will emit a 'beep' to confirm calibration and the unit will be restarted.

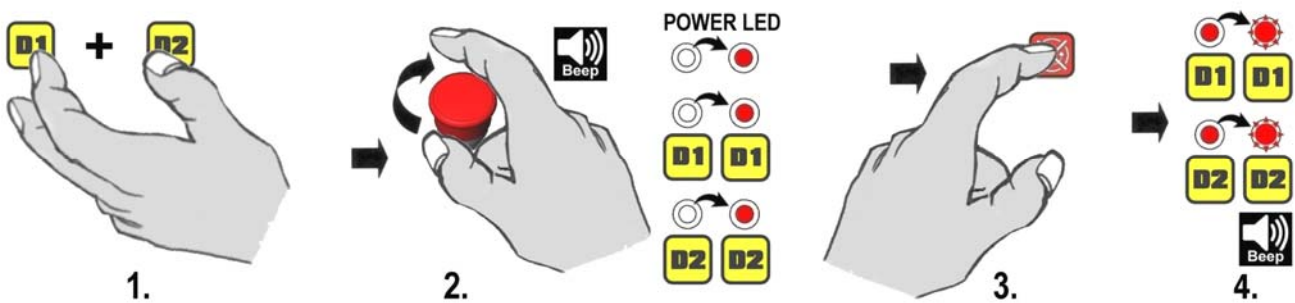

Temperature Compensation - Enable / Disable

With the control unit powered OFF;

1. Press and hold 'Auto-Reset' & 'Rotor Stop' keys.
2. Turn 'Power ON'; unit will emit a 'beep' and **Power LED will flash.**
3. Press 'Auto-Reset' key to enable (or disable) temperature compensation.
Power LED ON = Temperature Compensation ON (Enabled)
Power LED OFF = Temperature Compensation OFF (Disabled)
4. Press 'Rotor Stop' key to complete selection.
All LED's will flash and the unit will be restarted.

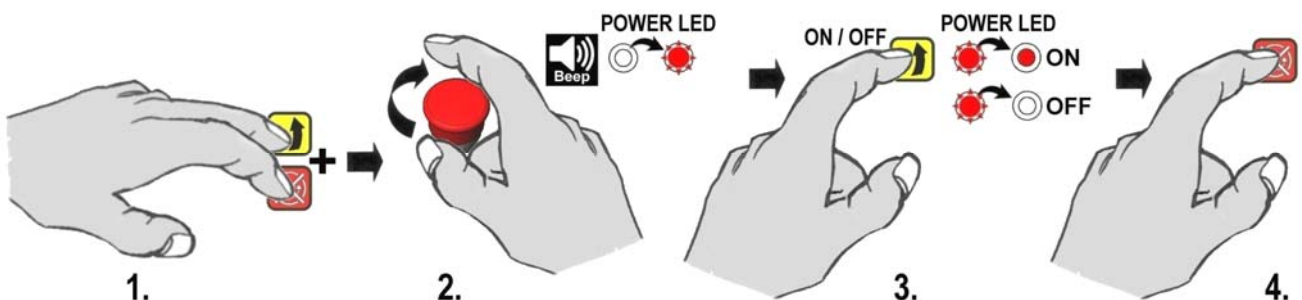

BANG-BANG / PWM MODE SELECTION – SLEW & TELE OUTPUTS

These control units are capable of operating 'Bang-Bang' or Proportional control valves and will be pre-set at the factory to match the specific machine it is being supplied with. Where a control unit is supplied as a replacement or is being used on a different machine it must be re-configured to match the particular valve set of the machine; *the procedure for this is stated below.*

Bang-Bang / Proportional (PWM Mode) Selection

With the control unit powered OFF;

1. Press and hold 'Lift Float' & 'Angle Float' keys.
2. Turn 'Power ON'; unit will emit a 'beep' and **Power, Lift Float & Angle Float LED's will flash.**
3. Press 'Rotor Stop'.
4. Press the dedicated key for the type of control valve fitted to the machine;
Select '**Angle Float**' key for machines equipped with **Proportional** valves.
Select '**Lift Float**' key for machines equipped with '**Bang-Bang**' valves.
Unit will emit a 'beep' to confirm selection and LED of selected key will remain lit.
5. Press '**Rotor Stop**' key to complete selection.
All LED's will flash and the unit will be restarted.

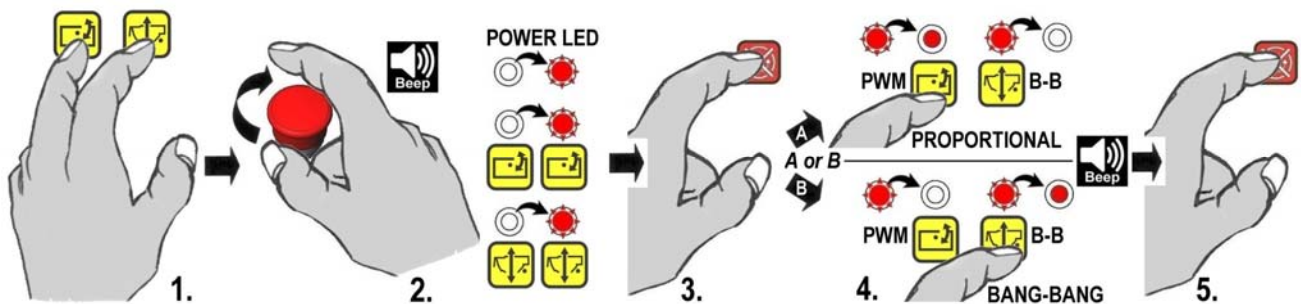

CONTROL UNIT CALIBRATION

If for any reason the controls should stop responding the unit will need to be calibrated; the procedure for this is shown below.

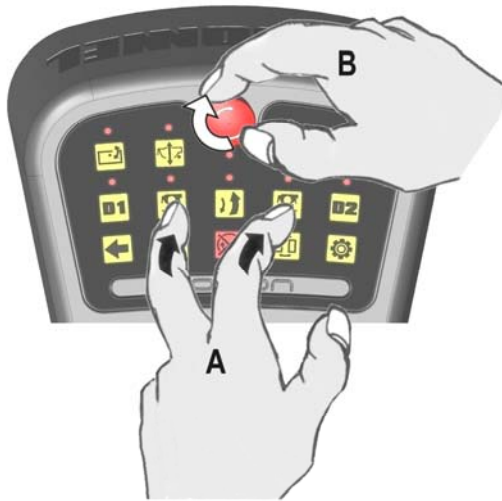

With the unit powered off; simultaneously press and hold both rotor direction buttons before then powering on the unit.

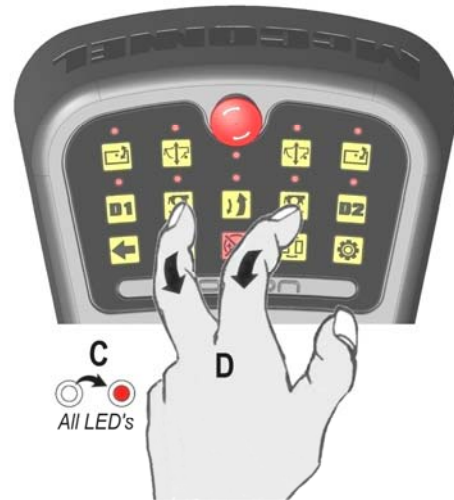

When all LED's light up; release both buttons.



Press and release the rotor stop button to enter calibration mode; all LED's will simultaneously flash to confirm.

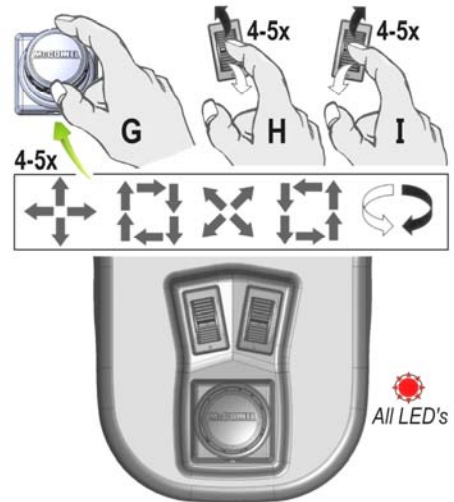

Operate the joystick through its complete range of movements 4 to 5 times then operate each toggle switch fully forwards and fully backwards 4 to 5 times. All LED's will flash continuously.



Press the rotor stop button once to exit calibration mode; all LED's will flash rapidly and the unit will emit a confirmation 'beep'.



Unit will automatically power off and back on.

ERROR / FAULT REPORTING

Error detection / reporting is indicated by specific flashing of the LED(s) on the control unit; depending on the nature of the fault these will be indicated by the just the Power LED flashing for a specific fault or by all the LED's flashing at the same time for a critical hardware fault. Refer to the chart below of details of errors/faults.

Note; on error detection flashes of the LED(s) will be continually repeated with a short delay between each specific sequence of flashes.

Specific Fault Detection / Report	
Power LED	Error / Fault
2 x Flash	<i>Analogue input fault</i>
3 x Flash	<i>System overcurrent</i>
4 x Flash	<i>Channel overcurrent</i>
5 x Flash	<i>System over temperature</i>
6 x Flash	<i>System under voltage</i>
7 x Flash	<i>System overvoltage</i>
8 x Flash	<i>Calibration fault</i>
9 x Flash	<i>Td channel cut-off overcurrent</i>
10 x Flash	<i>Td EEprom load error</i>

Critical Hardware Fault Detection / Report	
All LED's	Error / Fault
1 x Flash	<i>No error</i>
2 x Flash	<i>Out of time</i>
3 x Flash	<i>Watchdog fault</i>
4 x Flash	<i>Missing clock fault</i>
5 x Flash	<i>Over temperature</i>
6 x Flash	<i>Calibration error</i>
7 x Flash	<i>Code error</i>
8 x Flash	<i>CAN connection error</i>
10 x Flash	<i>Unspecified error</i>

INSTALLATION OF EVOLUTION MOUNTING KIT 22073.23

Mounting Kit (22073.23) is for installations where the tractor's armrest cannot be used as a mounting point for a control unit and/or as an alternative mounting method. Installation of the mounting kit requires partial disassembly of the control unit; the procedure is stated below.

Mounting Kit Components

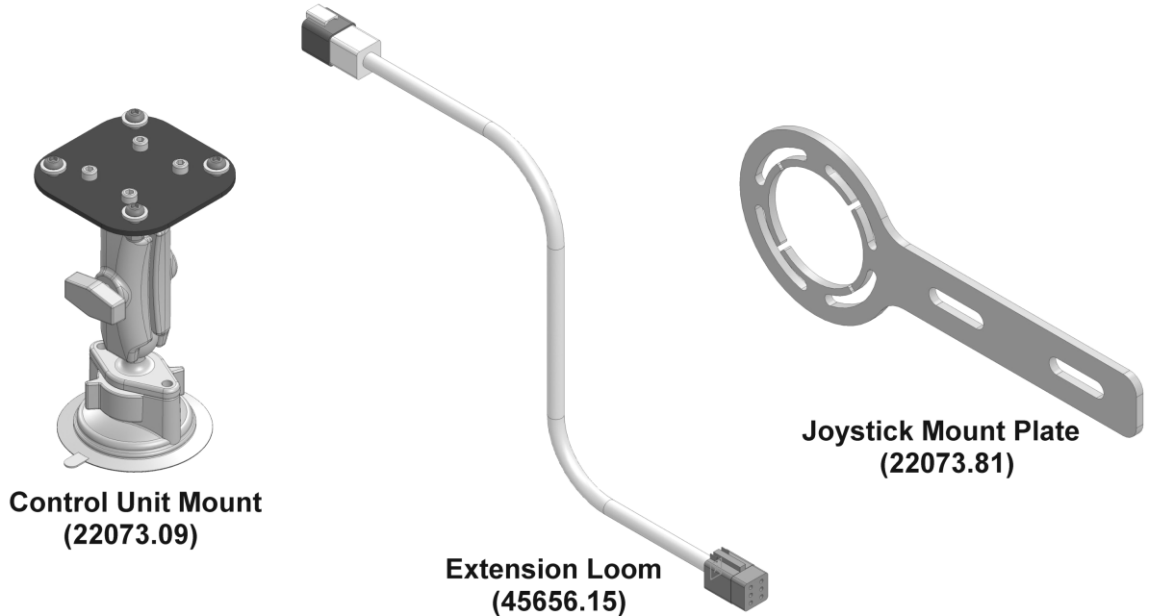

Disassembly of Evolution Control Unit

- A)** Unplug the electrical connection from base of joystick.
- B)** Remove the four screws from the top of the joystick and withdraw joystick downwards.
- C)** Remove the eight screws from armrest base plate and remove armrest.

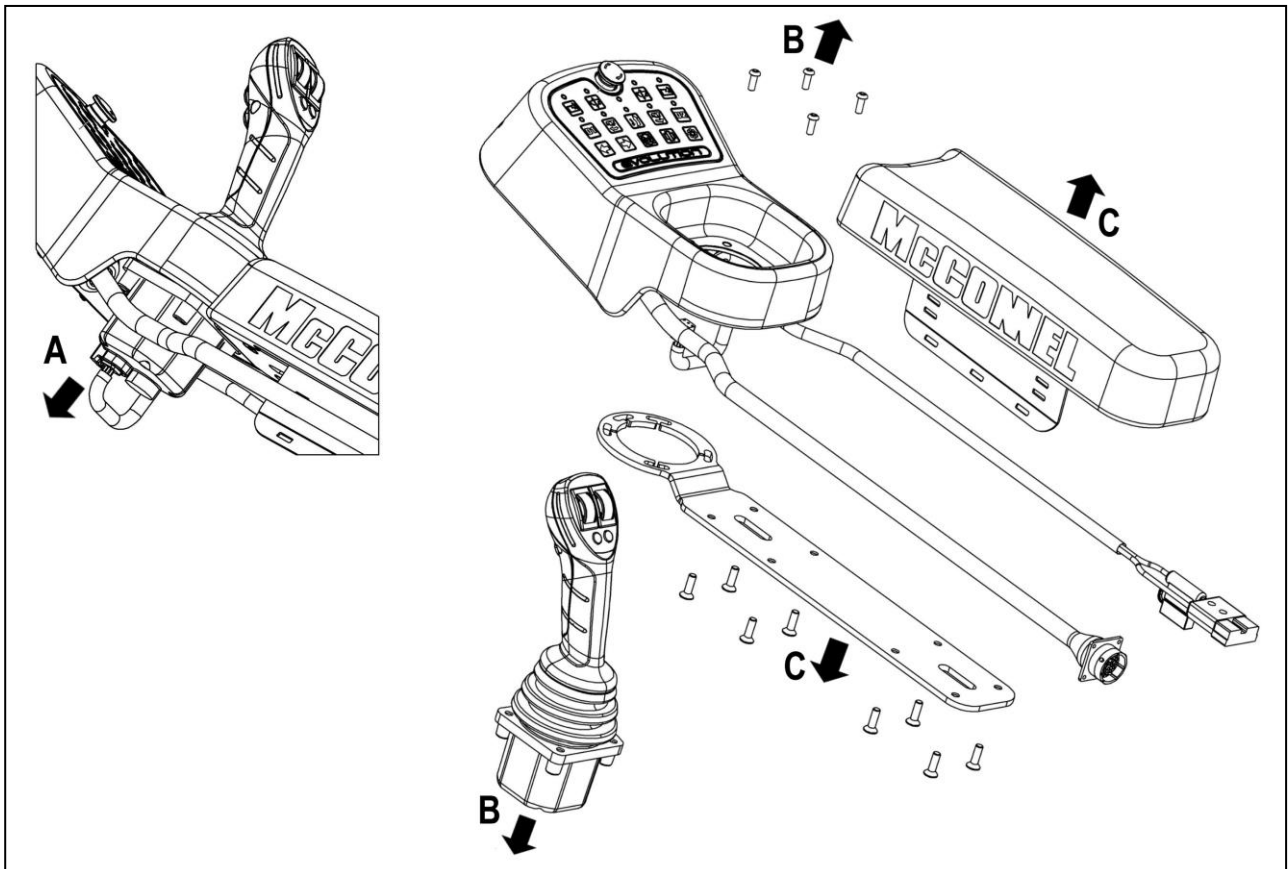

Mounting Kit Installation

- A) Fit joystick mount plate (22073.81) over joystick and secure with cap screws and washers.
- B) Connect extension loom (45656.15) between control unit loom and base of joystick.
- C) Attach mount (22073.09) to base of control pod and secure with cap screws and washers.

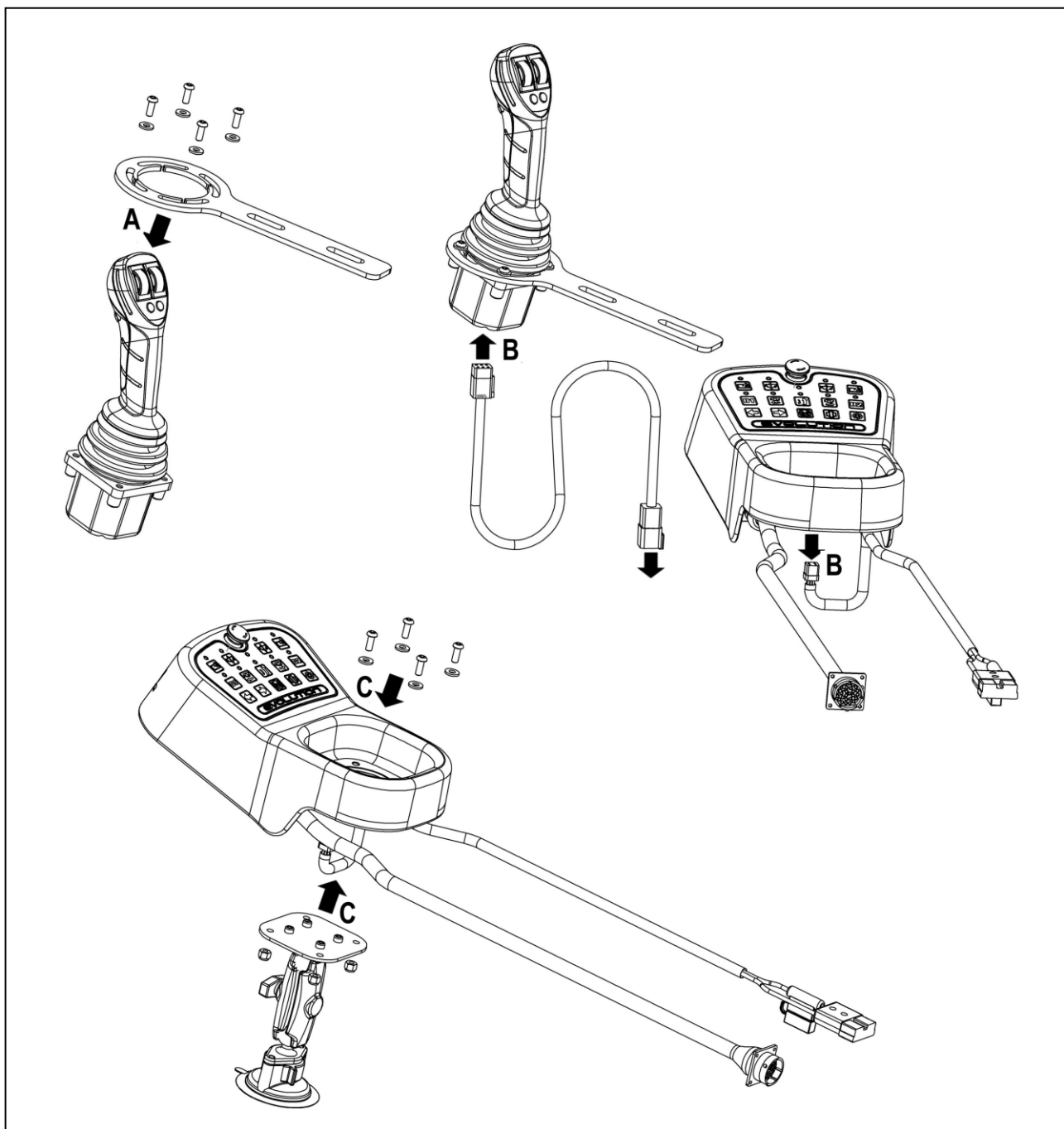



McConnel Limited, Temeside Works, Ludlow, Shropshire SY8 1JL. England.
Telephone: 01584 873131. Facsimile: 01584 876463. www.mcconnel.com