

Publication 631
January 2010
Part No. 22674.31
Revision: 01.11.18

1.6M FLAILHEAD

65HP, 77HP & 85HP BELT DRIVE Quad Drive Rotor



Operation & Parts Manual

Builds 7290953, 7291932, 7291934 and variants

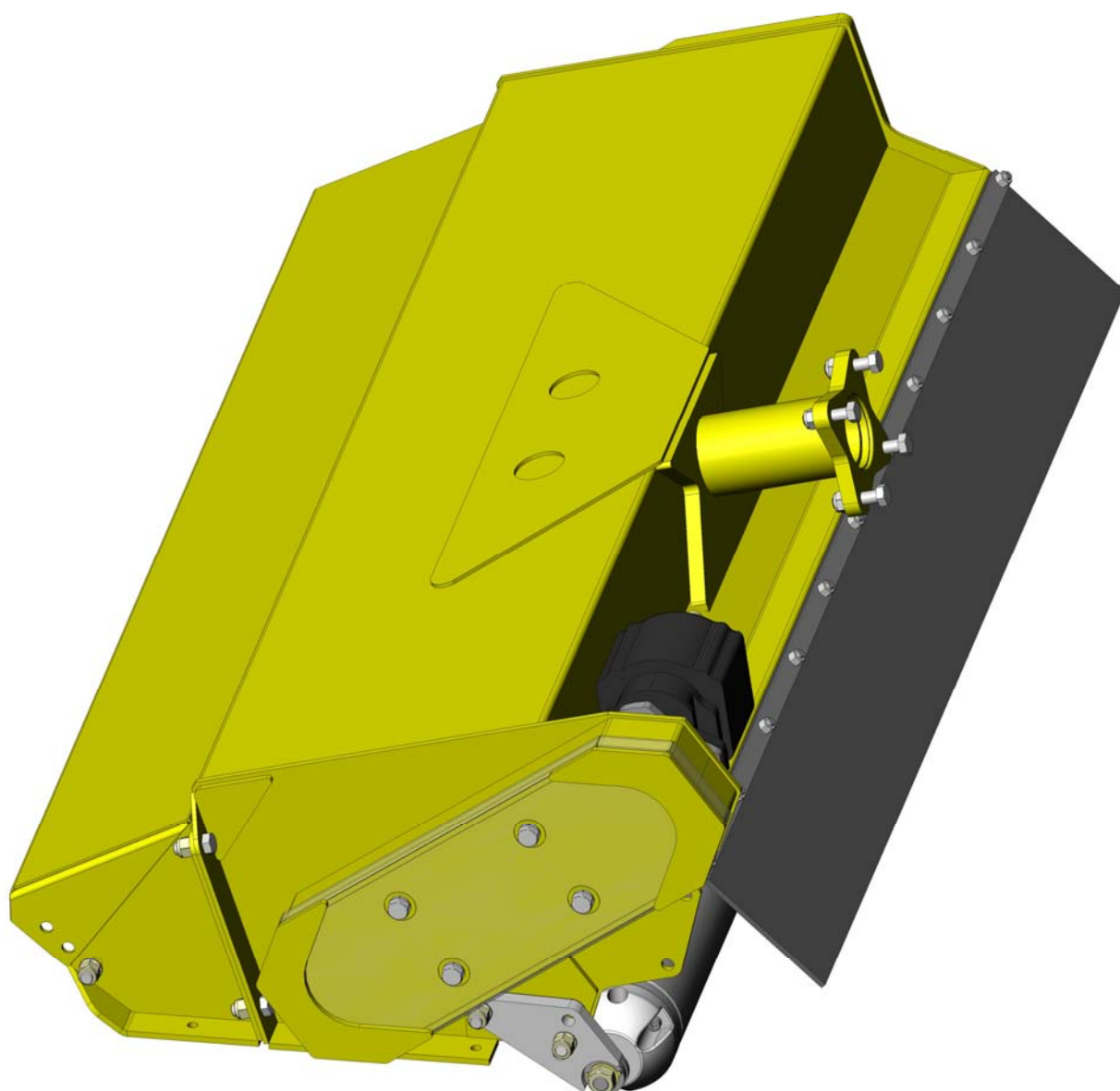

IMPORTANT

VERIFICATION OF WARRANTY REGISTRATION

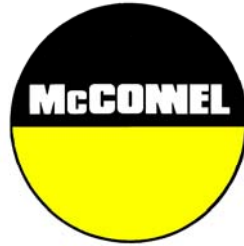

DEALER WARRANTY INFORMATION & REGISTRATION VERIFICATION

It is imperative that the selling dealer registers this machine with McConnel Limited before delivery to the end user – failure to do so may affect the validity of the machine warranty.

To register machines go to the McConnel Limited web site at www.mcconnel.com, log onto 'Dealer Inside' and select the 'Machine Registration button' which can be found in the Service Section of the site. Confirm to the customer that the machine has been registered in the section below.

Should you experience any problems registering a machine in this manner please contact the McConnel Service Department on 01584 875848.

Registration Verification

Dealer Name:
Dealer Address:
Customer Name:
Date of Warranty Registration:/...../..... Dealer Signature:

NOTE TO CUSTOMER / OWNER

Please ensure that the above section above has been completed and signed by the selling dealer to verify that your machine has been registered with McConnel Limited.

IMPORTANT: During the initial 'bedding in' period of a new machine it is the customer's responsibility to regularly inspect all nuts, bolts and hose connections for tightness and re-tighten if required. New hydraulic connections occasionally weep small amounts of oil as the seals and joints settle in – where this occurs it can be cured by re-tightening the connection – *refer to torque settings chart below*. The tasks stated above should be performed on an hourly basis during the first day of work and at least daily thereafter as part of the machines general maintenance procedure.

TORQUE SETTINGS FOR HYDRAULIC FITTINGS

HYDRAULIC HOSE ENDS		
BSP	Setting	Metric
1/4"	18 Nm	19 mm
3/8"	31 Nm	22 mm
1/2"	49 Nm	27 mm
5/8"	60 Nm	30 mm
3/4"	80 Nm	32 mm
1"	125 Nm	41 mm
1.1/4"	190 Nm	50 mm
1.1/2"	250 Nm	55 mm
2"	420 Nm	70 mm

PORT ADAPTORS WITH BONDED SEALS		
BSP	Setting	Metric
1/4"	34 Nm	19 mm
3/8"	47 Nm	22 mm
1/2"	102 Nm	27 mm
5/8"	122 Nm	30 mm
3/4"	149 Nm	32 mm
1"	203 Nm	41 mm
1.1/4"	305 Nm	50 mm
1.1/2"	305 Nm	55 mm
2"	400 Nm	70 mm

WARRANTY POLICY

WARRANTY REGISTRATION

All machines must be registered, by the selling dealer with McConnel Ltd, before delivery to the end user. On receipt of the goods it is the buyer's responsibility to check that the Verification of Warranty Registration in the Operator's Manual has been completed by the selling dealer.

1. LIMITED WARRANTIES

- 1.01. *All mounted machines supplied by McConnel Ltd are warranted to be free from defects in material and workmanship from the date of sale to the original purchaser for a period of 12 months, unless a different period is specified.*
All Self Propelled Machines supplied by McConnel Ltd are warranted to be free from defects in material and workmanship from the date of sale to the original purchaser for a period of 12 months or 1500 hours. Engine warranty will be specific to the Manufacturer of that unit.
- 1.02. *All spare parts supplied by McConnel Ltd and purchased by the end user are warranted to be free from defects in material and workmanship from the date of sale to the original purchaser for a period of 6 months. All parts warranty claims must be supported by a copy of the failed part invoice to the end user. We cannot consider claims for which sales invoices are not available.*
- 1.03. *The warranty offered by McConnel Ltd is limited to the making good by repair or replacement for the purchaser any part or parts found, upon examination at its factory, to be defective under normal use and service due to defects in material or workmanship. Returned parts must be complete and unexamined. Pack the component(s) carefully so that any transit damage is avoided. All ports on hydraulic items should be drained of oil and securely plugged to prevent seepage and foreign body ingress. Certain other components, electrical items for example, may require particular care when packing to avoid damage in transit.*
- 1.04. *This warranty does not extend to any product from which McConnel Ltd's serial number plate has been removed or altered.*
- 1.05. *The warranty policy is valid for machines registered in line with the terms and conditions detailed and on the basis that the machines do not extend a period of 24 months or greater since their original purchase date, that is the original invoice date from McConnel Limited.*
Machines that are held in stock for more than 24 months cannot be registered for warranty.
- 1.06. *This warranty does not apply to any part of the goods, which has been subjected to improper or abnormal use, negligence, alteration, modification, fitment of non-genuine parts, accident damage, or damage resulting from contact with overhead power lines, damage caused by foreign objects (e.g. stones, iron, material other than vegetation), failure due to lack of maintenance, use of incorrect oil or lubricants, contamination of the oil, or which has served its normal life. This warranty does not apply to any expendable items such as blades, belts, clutch linings, filter elements, flails, flap kits, skids, soil engaging parts, shields, guards, wear pads, pneumatic tyres or tracks.*
- 1.07. *Temporary repairs and consequential loss - i.e. oil, downtime and associated parts are specifically excluded from the warranty.*
- 1.08. *Warranty on hoses is limited to 12 months and does not include hoses which have suffered external damage. Only complete hoses may be returned under warranty, any which have been cut or repaired will be rejected.*
- 1.09. *Machines must be repaired immediately a problem arises. Continued use of the machine after a problem has occurred can result in further component failures, for which McConnel Ltd cannot be held liable, and may have safety implications.*
- 1.10. *If in exceptional circumstances a non McConnel Ltd part is used to effect a repair, warranty reimbursement will be at no more than McConnel Ltd's standard dealer cost for the genuine part.*

- 1.11. *Except as provided herein, no employee, agent, dealer or other person is authorised to give any warranties of any nature on behalf of McConnell Ltd.*
- 1.12. *For machine warranty periods in excess of 12 months the following additional exclusions shall apply:*
 - 1.12.1. *Hoses, exposed pipes and hydraulic tank breathers.*
 - 1.12.2. *Filters.*
 - 1.12.3. *Rubber mountings.*
 - 1.12.4. *External electric wiring.*
 - 1.12.5. *Bearings and seals*
 - 1.12.6. *External Cables, Linkages*
 - 1.12.7. *Loose/Corroded Connections, Light Units, LED's*
 - 1.12.8. *Comfort items such as Operator Seat, Ventilation, Audio Equipment*
- 1.13. *All service work, particularly filter changes, must be carried out in accordance with the manufacturer's service schedule. Failure to comply will invalidate the warranty. In the event of a claim, proof of the service work being carried out may be required.*
- 1.14. *Repeat or additional repairs resulting from incorrect diagnosis or poor quality previous repair work are excluded from warranty.*

NB Warranty cover will be invalid if any non-genuine parts have been fitted or used. Use of non-genuine parts may seriously affect the machine's performance and safety. McConnell Ltd cannot be held responsible for any failures or safety implications that arise due to the use of non-genuine parts.

2. REMEDIES AND PROCEDURES

- 2.01. *The warranty is not effective unless the Selling Dealer registers the machine, via the McConnell web site and confirms the registration to the purchaser by completing the confirmation form in the operator's manual.*
- 2.02. *Any fault must be reported to an authorised McConnell Ltd dealer as soon as it occurs. Continued use of a machine, after a fault has occurred, can result in further component failure for which McConnell Ltd cannot be held liable.*
- 2.03. *Repairs should be undertaken within two days of the failure. Claims submitted for repairs undertaken more than 2 weeks after a failure has occurred, or 2 days after the parts were supplied will be rejected, unless the delay has been authorised by McConnell Ltd. Please note that failure by the customer to release the machine for repair will not be accepted as a reason for delay in repair or submitting warranty claims.*
- 2.04. *All claims must be submitted, by an authorised McConnell Ltd Service Dealer, within 30 days of the date of repair.*
- 2.05. *Following examination of the claim and parts, McConnell Ltd will pay, at their discretion, for any valid claim the invoiced cost of any parts supplied by McConnell Ltd and appropriate labour and mileage allowances if applicable.*
- 2.06. *The submission of a claim is not a guarantee of payment.*
- 2.07. *Any decision reached by McConnell Ltd. is final.*

3. LIMITATION OF LIABILITY

- 3.01. *McConnell Ltd disclaims any express (except as set forth herein) and implied warranties with respect to the goods including, but not limited to, merchantability and fitness for a particular purpose.*
- 3.02. *McConnell Ltd makes no warranty as to the design, capability, capacity or suitability for use of the goods.*
- 3.03. *Except as provided herein, McConnell Ltd shall have no liability or responsibility to the purchaser or any other person or entity with respect to any liability, loss, or damage caused or alleged to be caused directly or indirectly by the goods including, but not limited to, any indirect, special, consequential, or incidental damages resulting from the use or operation of the goods or any breach of this warranty. Notwithstanding the above limitations and warranties, the manufacturer's liability hereunder for damages incurred by the purchaser or others shall not exceed the price of the goods.*
- 3.04. *No action arising out of any claimed breach of this warranty or transactions under this warranty may be brought more than one (1) year after the cause of the action has occurred.*

4. MISCELLANEOUS

- 4.01. McConnel Ltd may waive compliance with any of the terms of this limited warranty, but no waiver of any terms shall be deemed to be a waiver of any other term.*
- 4.02. If any provision of this limited warranty shall violate any applicable law and is held to be unenforceable, then the invalidity of such provision shall not invalidate any other provisions herein.*
- 4.03. Applicable law may provide rights and benefits to the purchaser in addition to those provided herein.*

McConnel Limited



DECLARATION OF CONFORMITY

Conforming to EU Machinery Directive 2006/42/EC

We,

McCONNEL LIMITED, Temeside Works, Ludlow, Shropshire SY8 1JL, UK

Hereby declare that:

The Product; *Hydraulic Arm Mounted Flailhead*

Product Code; *BD12, BD16, F110, F112, F115, F012, F016*

Serial No. & Date Type

Manufactured in; *United Kingdom*

Complies with the required provisions of the Machinery Directive 2006/42/EC
The machinery directive is supported by the following harmonized standards;

- BS EN ISO 12100 (2010) Safety of machinery – General principles for design – Risk assessment and risk reduction.
- BS EN 349 (1993) + A1 (2008) Safety of machinery - Minimum distances to avoid the entrapment with human body parts.
- BS EN ISO 14120 (2015) Safety of machinery - Guards general requirements for the design and construction of fixed and movable guards.
- BS EN 4413 (2010) Hydraulic fluid power. Safety requirements for systems and their components.

McCONNEL LIMITED operates an ISO 9001:2008 quality management system, certificate number: FM25970.

This system is continually assessed by the;

British Standards Institution (BSI), Beech House, Milton Keynes, MK14 6ES, UK
BSI is accredited by UK Accreditation Service, accreditation number: UKAS 003.
The EC declaration only applies if the machine stated above is used in accordance with the operating instructions.

Signed *Responsible Person*
CHRISTIAN DAVIES on behalf of McCONNEL LIMITED

Status: *General Manager*

Date: *January 2018*

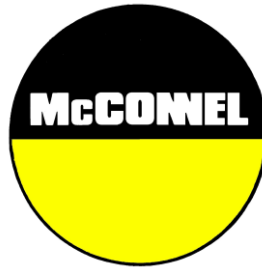

For Safety and Performance...

ALWAYS READ THE BOOK FIRST

McCONEL LIMITED

**Temeside Works
Ludlow
Shropshire
England**

**Telephone: +44 (0)1584 873131
www.mcconel.com**

- NOISE STATEMENT -

The equivalent daily personal noise exposure from this machine measured at the operators' ear is within the range 78 – 85 dB, these figures apply to a normal distribution of use where the noise fluctuates between zero and maximum. The figures assume that the machine is fitted to a tractor with a 'quiet' cab with the windows closed in a generally open environment. We recommend that the windows are kept closed. With the cab rear window open the equivalent daily personal noise exposure will increase to a figure within the range 82 – 88 dB. At an equivalent daily noise exposure level of 85 – 90 dB ear protection is recommended and must always be used if any window is left open.



Operating, servicing and maintaining this equipment can expose you to chemicals including gasoline, diesel fuel, lubricants, petroleum products, engine exhaust, carbon monoxide, and phthalates, which are known to the State of California to cause cancer and birth defects or other reproductive harm. To minimize exposure, avoid breathing exhaust, do not idle the engine except as necessary, service your vehicle in a well-ventilated area and wear gloves or wash your hands frequently when servicing your vehicle. Battery posts, terminals and related accessories contain lead and lead compounds, chemicals known to the state of California to cause cancer, birth defects or other reproductive harm. For more information go to www.P65Warnings.ca.gov. This website, operated by California's Office of Environmental Health Hazard Assessment, provides information about these chemicals and how individuals may be exposed to them.

CONTENTS

Operator Section

General Information	1
Safety Information	3
Safety & Information Decals	7
Flailhead Checks	8
Cutting Limitations	11
Roller Positions	11
Flailhead Arrangement – Grass & Verge Mowing	12
Flailhead Arrangement – Hedge Cutting	16
Flail Identification	20
Maintenance	21
Rotor Shaft Alignment	23
Belt Pulley Alignment	25

Parts Section

Flailhead Assembly	29
Flailhead Casing Assembly	30
Rotor Assemblies	31
Motor Modules	35
Bearing Support	39
Motor Plates	40
Drive Module	42
Roller Assemblies	44
Front Flap Kits	50
Skid Kit (Option)	52
Decal Kits	51

GENERAL INFORMATION

Read this manual before fitting or operating the machine or accessory. Whenever any doubt exists contact your local dealer or the McConnell Service Department for assistance.

Only use 'Genuine McConnell Parts' on McConnell machinery and equipment.

DEFINITIONS: *The following definitions apply throughout this manual;*

⚠ DANGER

DANGER: Alerts to a hazardous situation which will result in death or serious injury if not observed carefully.

⚠ WARNING

WARNING: Alerts to a hazardous situation which could result in death or serious injury if not observed carefully.

⚠ CAUTION

CAUTION: Alerts to a hazardous situation which could result in damage to the machine and/or equipment if not observed carefully.

NOTICE

NOTICE: Specific or general information considered important or useful to emphasise.

LEFT HAND (LH) & RIGHT HAND (RH): *These terms are applicable to the machine when fitted to the tractor and viewed from the rear; these terms also apply to tractor references.*

SERIAL PLATE

All machines are equipped with a serial number plate containing important information relating to the machine including a unique serial number used for identification purposes.

Note: Images in this manual are provided for instruction and informational purposes only and may not show components in their entirety. In certain instances images may appear different to the actual machine; where this occurs the general procedure will be basically the same. E&OE.

MACHINE & DEALER INFORMATION

Record the serial number of your machine on this page and always quote it when ordering parts. Whenever information concerning the machine is requested remember to also state the make and model of tractor to which the machine is fitted.

Machine Serial Number:	Installation Date:
Machine Model Details:	
Dealer Name & Branch:	
Dealer Address:	
Dealer Telephone No:	
Dealer Email Address:	



This machine has the potential to be extremely dangerous - in the wrong hands it can kill or maim; It is therefore imperative that both owner and operator of the machine reads and understands the following section to ensure they are fully aware of the dangers that do, or may exist, and their responsibilities surrounding the use and operation of the machine.

The operator of this machine is responsible not only for their own safety but equally for the safety of others who may come into the close proximity of the machine, as the owner you are responsible for both.

When the machine is not in use the cutting head should be lowered to rest on the ground. In the event of any fault being detected with the machine's operation it must be stopped immediately and not used again until the fault has been corrected by a qualified technician.

POTENTIAL SIGNIFICANT DANGERS ASSOCIATED WITH THE USE OF THIS MACHINE:

- ▲ *Being hit by debris thrown by rotating components.*
- ▲ *Being hit by machine parts ejected through damage during use.*
- ▲ *Being caught on a rotating power take-off (PTO) shaft.*
- ▲ *Being caught in other moving parts i.e.: belts, pulleys and cutting heads.*
- ▲ *Electrocution from Overhead Power Lines (by contact with or 'flashover' from).*
- ▲ *Being hit by cutting heads or machine arms as they move.*
- ▲ *Becoming trapped between tractor and machine when hitching or unhitching.*
- ▲ *Tractor overbalancing when machine arm is extended.*
- ▲ *Injection of high-pressure oil from hydraulic hoses or couplings.*
- ▲ *Machine overbalancing when freestanding (out of use).*
- ▲ *Road traffic accidents due to collision or debris on the road.*
- ▲ *Burn risk from hot components.*

BEFORE USING THIS MACHINE YOU MUST:

- ▲ *Ensure you read all sections of the operator handbook.*
- ▲ *Ensure the operator is, or has been, properly trained to use the machine.*
- ▲ *Ensure the operator has been issued with and reads the operator handbook.*
- ▲ *Ensure the operator understands and follows the instructions in operator handbook.*
- ▲ *Ensure the tractor front, rear and sides are fitted with metal mesh or polycarbonate guards of suitable size and strength to protect the operator against thrown debris or parts.*
- ▲ *Ensure tractor guards are fitted correctly, are undamaged and kept properly maintained.*
- ▲ *Ensure that all machine guards are in position, are undamaged, and are kept maintained in accordance with the manufacturer's recommendations.*
- ▲ *Ensure flails and their fixings are of a type recommended by the manufacturer, are securely attached and that none are missing or damaged.*
- ▲ *Ensure hydraulic pipes are carefully and correctly routed to avoid damage by chaffing, stretching or pinching and that they are held in place with the correct fittings.*
- ▲ *Always follow the manufacturer's instructions for attachment and removal of the machine from the tractor.*
- ▲ *Check that the machine fittings and couplings are in good condition.*
- ▲ *Ensure the tractor meets the minimum weight recommendations of the machine's manufacturer and that ballast is used as necessary.*
- ▲ *Always inspect the work area thoroughly before starting to note obstacles and remove wire, bottles, cans and other debris.*
- ▲ *Use clear suitably sized warning signs to alert others to the nature of the machine working within that area. Signs should be placed at both ends of the work site. (It is recommended that signs used are of a size and type specified by the Department of Transport and positioned in accordance with their, and the Local Highways Authority, guidelines).*
- ▲ *Ensure the operator is protected from noise. Ear defenders should be worn and tractor cab doors and windows must be kept closed. Machine controls should be routed through proprietary openings in the cab to enable all windows to be shut fully.*
- ▲ *Always work at a safe speed taking account of the conditions i.e.: terrain, highway proximity and obstacles around and above the machine. Extra special attention should be applied to Overhead Power Lines. Some of our machines are capable of reach in excess of 8 metres (26 feet) this means they have the potential to well exceed, by possibly 3 metres (9' 9"), the lowest legal minimum height of 5.2 metres from the ground for 11,000 and 33,000 volt power lines. It cannot be stressed enough the dangers that surround this capability, it is therefore vital that the operator is fully aware of the maximum height and reach of the machine, and that they are fully conversant with all aspects regarding the safe minimum distances that apply when working with machines in close proximity to Power Lines. (Further information on this subject can be obtained from the Health & Safety Executive or your Local Power Company).*

- ▲ *Always disengage the machine, kill the tractor engine, remove and pocket the key before dismounting for any reason.*
- ▲ *Always clear up all debris left at the work area, it may cause hazard to others.*
- ▲ *Always ensure when you remove your machine from the tractor that it is left in a safe and stable position using the stands and props provided and secured if necessary.*

WHEN NOT TO USE THIS MACHINE:

- ▲ *Never attempt to use this machine if you have not been trained to do so.*
- ▲ *Never use a machine until you have read and understood the operator handbook, are familiar with it, and practiced the controls.*
- ▲ *Never use a machine that is poorly maintained.*
- ▲ *Never use a machine if guards are missing or damaged.*
- ▲ *Never use a machine on which the hydraulic system shows signs of wear or damage.*
- ▲ *Never fit, or use, a machine on a tractor that does not meet the manufacturer's minimum specification level.*
- ▲ *Never use a machine fitted to a tractor that does not have suitable front, rear and side(s) cab guarding made of metal mesh or polycarbonate.*
- ▲ *Never use the machine if the tractor cab guarding is damaged, deteriorating or badly fitted.*
- ▲ *Never turn a machine cutting head to an angle that causes debris to be ejected towards the cab.*
- ▲ *Never start or continue to work a machine if people are nearby or approaching - Stop and wait until they are at a safe distance before continuing. WARNING: Some cutting heads may continue to 'freewheel' for up to 40 seconds after being stopped.*
- ▲ *Never attempt to use a machine on materials in excess of its capability.*
- ▲ *Never use a machine to perform a task it has not been designed to do.*
- ▲ *Never operate the tractor or machine controls from any position other than from the driving seat, especially whilst hitching or unhitching the machine.*
- ▲ *Never carry out maintenance of a machine or a tractor whilst the engine is running – the engine should be switched off, the key removed and pocketed.*
- ▲ *Never leave a machine unattended in a raised position – it should be lowered to the ground in a safe position on a level firm site.*
- ▲ *Never leave a tractor with the key in or the engine running.*
- ▲ *Never carry out maintenance on any part or component of a machine that is raised unless that part or component has been properly substantially braced or supported.*
- ▲ *Never attempt to detect a hydraulic leak with your hand – use a piece of cardboard.*
- ▲ *Never allow children near to, or play on, a tractor or machine under any circumstances.*

ADDITIONAL SAFETY ADVICE

Training

Operators need to be competent and fully capable of operating this machine in a safe and efficient way prior to attempting to use it in any public place. We advise therefore that the prospective operator make use of relevant training courses available such as those run by the Agricultural Training Board, Agricultural Colleges, Dealers and McConnel.

Working in Public Places

When working in public places such as roadsides, consideration should be paid to others in the vicinity. Stop the machine immediately when pedestrians, cyclists and horse riders etc. pass. Restart only when they are at a distance that causes no risk to their safety.

Warning Signs

It is advisable that any working area be covered by suitable warning signs and statutory in public places. Signs should be highly visible and well placed in order to give clear advanced warning of the hazard. Contact the Department of Transport or your Local Highways Authority to obtain detailed information on this subject. The latter should be contacted prior to working on the public highway advising them of the time and location of the intended work asking what is required by way of signs and procedure. – *‘Non- authorised placement of road signs may create offences under the Highways Act’.*

Suggested Warning Signs Required

‘Road works ahead’ warning sign with a supplementary ‘Hedge cutting’ plate. ‘For 1 mile’ or appropriate shorter distance may be added to the plate.

‘Road narrows’ warning signs with supplementary ‘Single file traffic’ plate.

White on blue ‘Keep right’ () arrow sign on rear of machine.*

** Note – this applies to UK Market machines where traffic passes to the right of a machine working in the same direction as the traffic flow. The direction, use and colour of the arrow sign will depend on the country of use and the Local Highway Authorities regulations in the locality.*

Use of Warning Signs

- ▲ *On two-way roads one set of signs is needed facing traffic in each direction.*
- ▲ *Work should be within 1 mile of the signs.*
- ▲ *Work only when visibility is good and at times of low risk e.g.: NOT during ‘rush-hour’.*
- ▲ *Vehicles should have an amber-flashing beacon.*
- ▲ *Ideally, vehicles should be conspicuously coloured.*
- ▲ *Debris should be removed from the road and path as soon as practicable, and at regular intervals, wearing high visibility clothing and before removing the hazard warning signs.*
- ▲ *Collect all road signs promptly when the job is completed.*

Although the information stated here covers a wide range of safety subjects it is impossible to predict every eventuality that can occur under differing circumstances whilst operating this machine. No advice given here can replace ‘good common sense’ and ‘total awareness’ at all times, but will go a long way towards the safe use of your McConnel machine.

SAFETY & INFORMATION DECALS

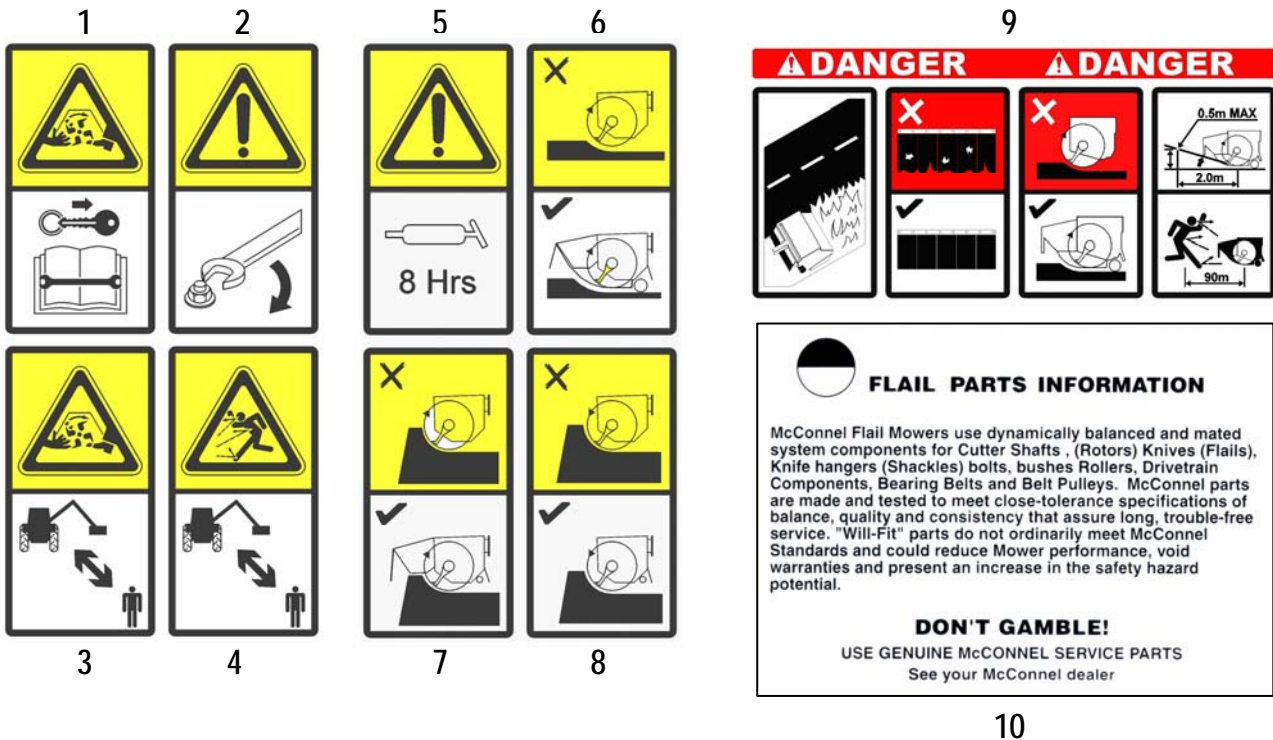

1. **Caution!** Rotating blades; keep clear of machine, stop machine (wait for rotor to stop), remove vehicle key and read the book first before performing any service or maintenance.
2. **Caution!** Keep all nuts and bolts tight.
3. **Caution!** Rotating components; keep clear of the working machine.
4. **Caution!** Thrown objects risk; keep all persons at a safe distance from the working machine.
5. **Caution!** Lubricate greasing points every 8 working hours.
6. **Caution!** Grass/Verge Mowing; front hood, front flap, rear roller and rear flap must be fitted and correctly adjusted when using the machine for grass and verge mowing. Flaps must be in good condition.
7. **Caution!** Hedging (Uphill cutting); front hood, front flap and rear flap must always be fitted and correctly adjusted. Rear roller should be placed into the raised position. Flaps must be in good condition.
8. **Caution!** Hedging (Downhill cutting); front hood may be removed; rear flap must be fitted and rear roller placed into the raised position. Flap must be in good condition.
9. **Danger!** Road side mowing. Flaps must be in good condition. Do not work if front hood, front flaps, rear roller and rear flaps not fitted. Front hood, front flaps, rear roller and rear flaps must be fitted. Adjust front hood to the correct height position for verge mowing. A extended straight line from the bottom of the rotor and bottom of the front flap should not be higher than 0.5m at a horizontal distance of 2.0m from the rotor. Keep all persons at 90m from the working machine, stop machine if persons are closer. *Refer to front hood height setting section for details.*
10. **Important!** Parts information; for safety and performance only use 'Genuine McConnel Service Parts'.

FLAILHEAD CHECKS

Ensure that all bolts in the locations indicated below are tightened to the torque figures stated.

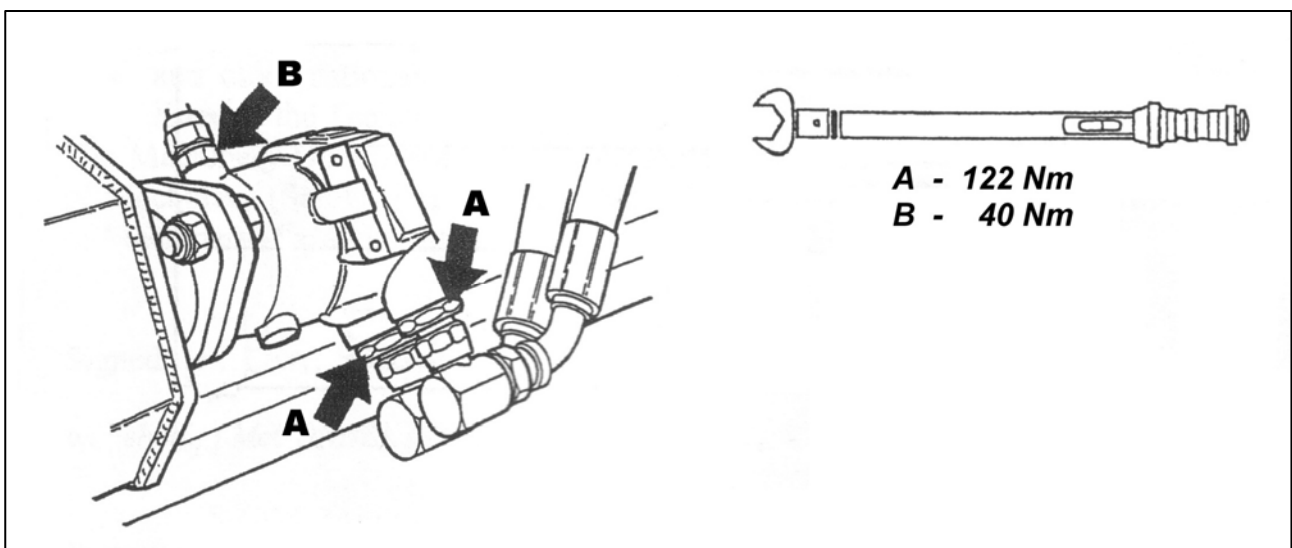
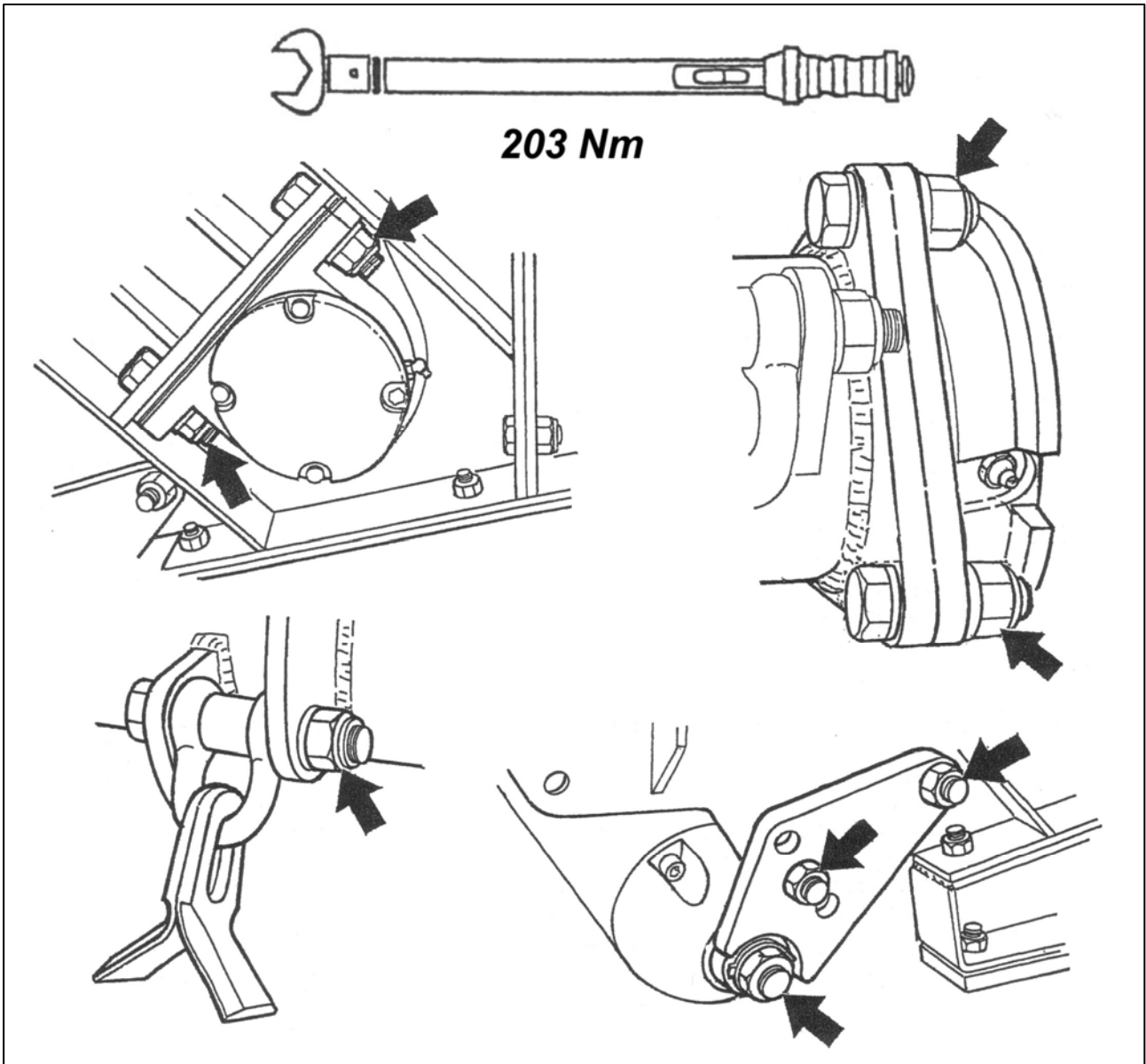

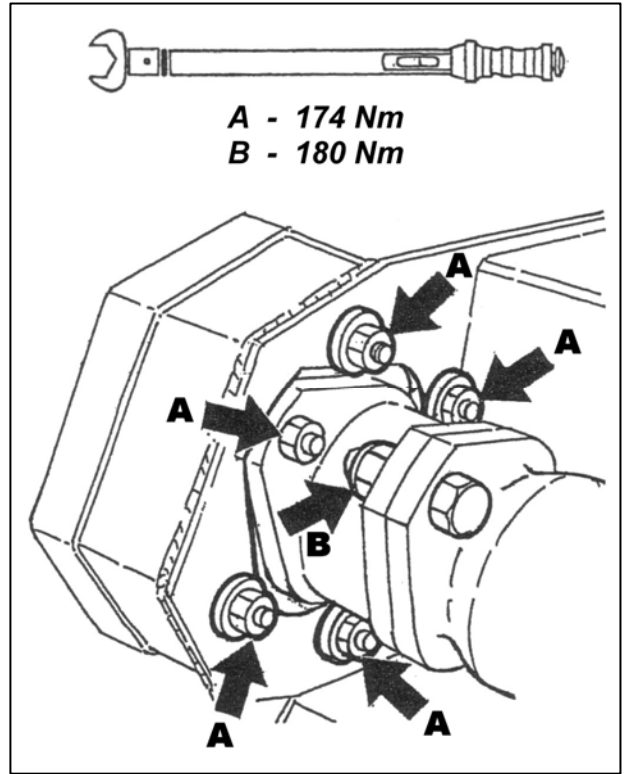
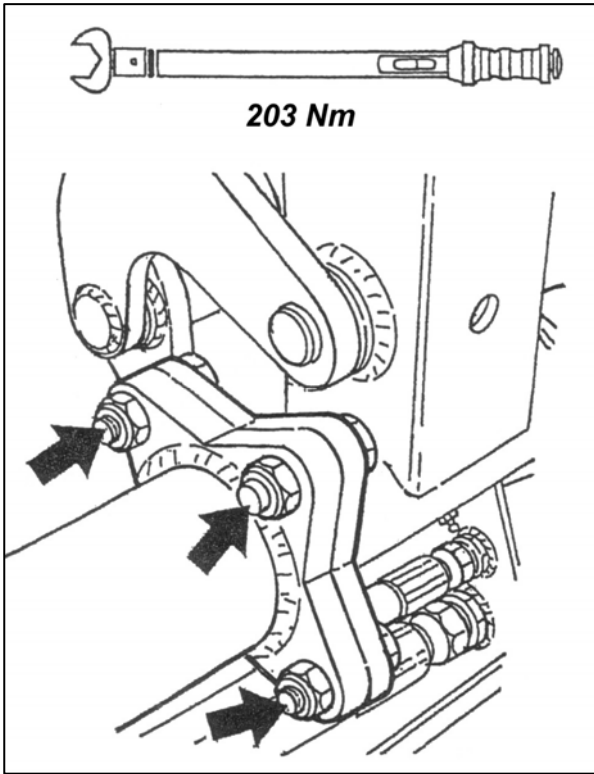

BELT TENSION

Checking Belt Tension

Belt tension is correct when: 'comfortable' finger pressure exerted on the belt at the mid-way point between the pulleys causes the tooth tips of the belt to be deflected downwards to the level of the thick red line on the belt tension decal – see *diagram opposite*.

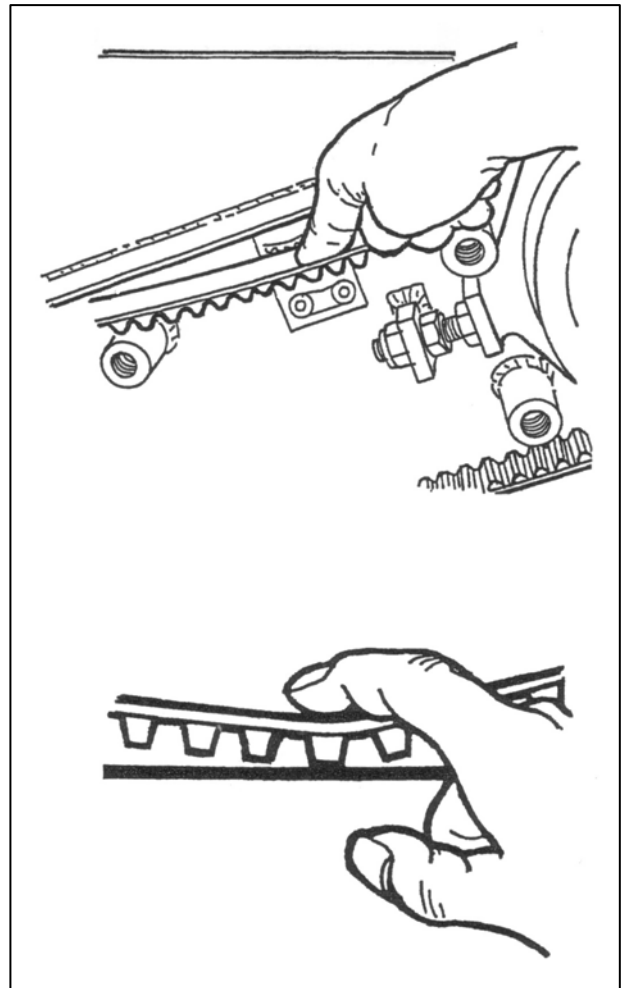

PULLEYS

Pulley Alignment

The diagrams opposite illustrate correct and incorrect alignment of the flailhead belt.

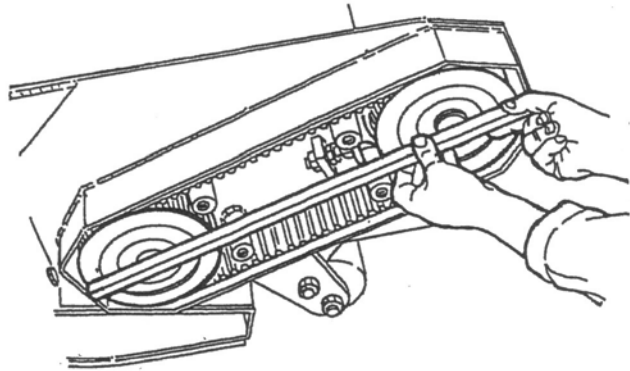

A – Correct:
Belt aligned.

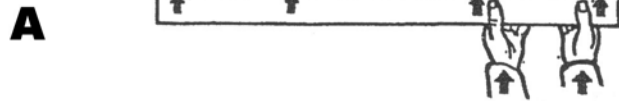

B – Incorrect:
Angular misalignment of the belt.

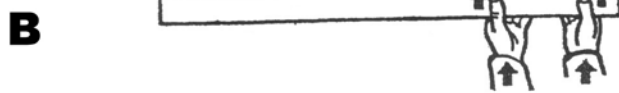

C – Incorrect:
Parallel misalignment of the belt.

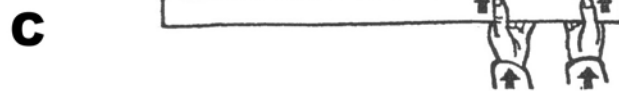

OPERATION

Material Thickness Cutting Limitations



Roller Positions

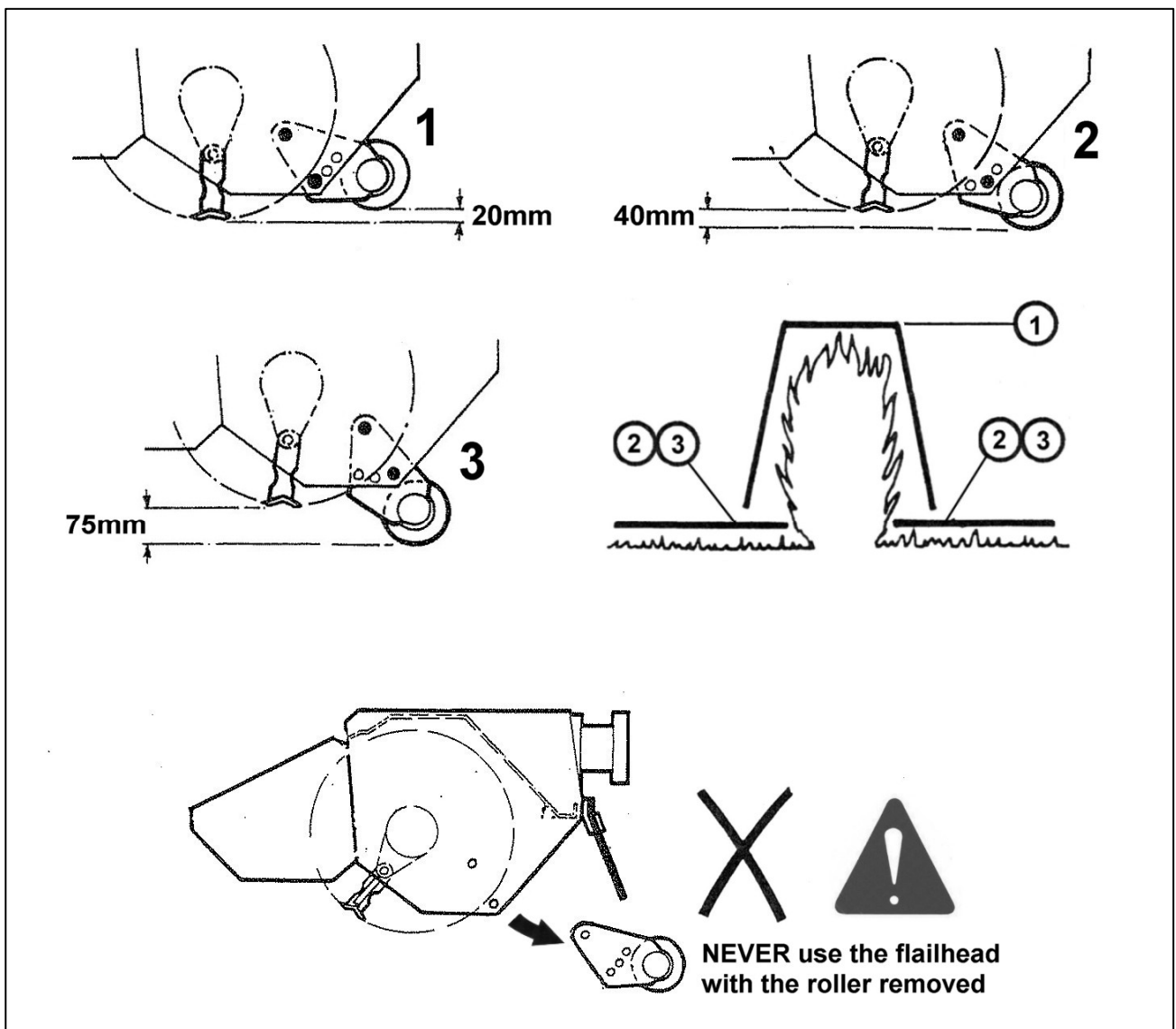

Preliminary Precautions

Inspect the work area prior to operation, remove all hazardous materials and note the locations of immovable obstructions.

FLAILHEAD ARRANGEMENT – GRASS & VERGE MOWING

Roller Height

The roller position must always be set below the level of the skids, or rotor if skids are not fitted - *refer to roller positions on previous page.*

Rotor Direction

When mowing the rotor must always cut with an upwards rotation.

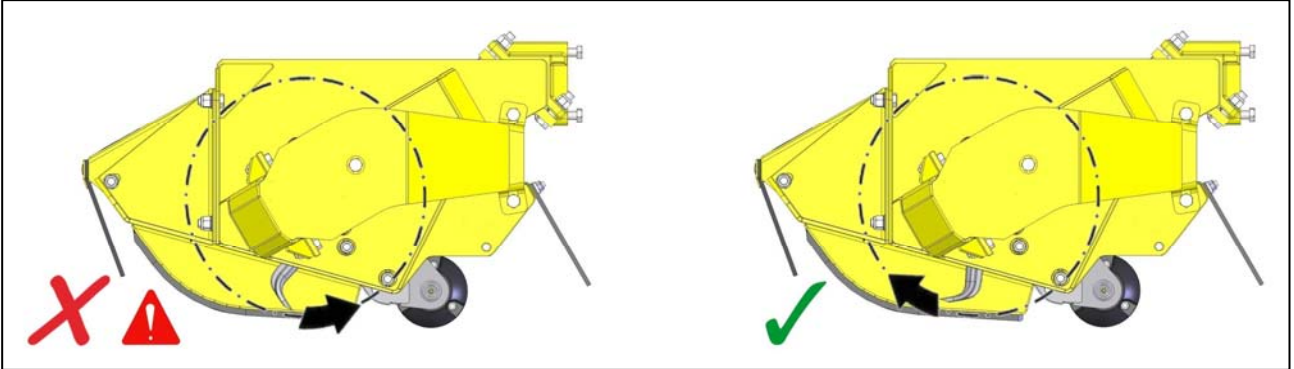

Front Hood

The front hood has 4 adjustment positions for height – the lowest possible position which allows the material to be cut to enter the head should always be used.

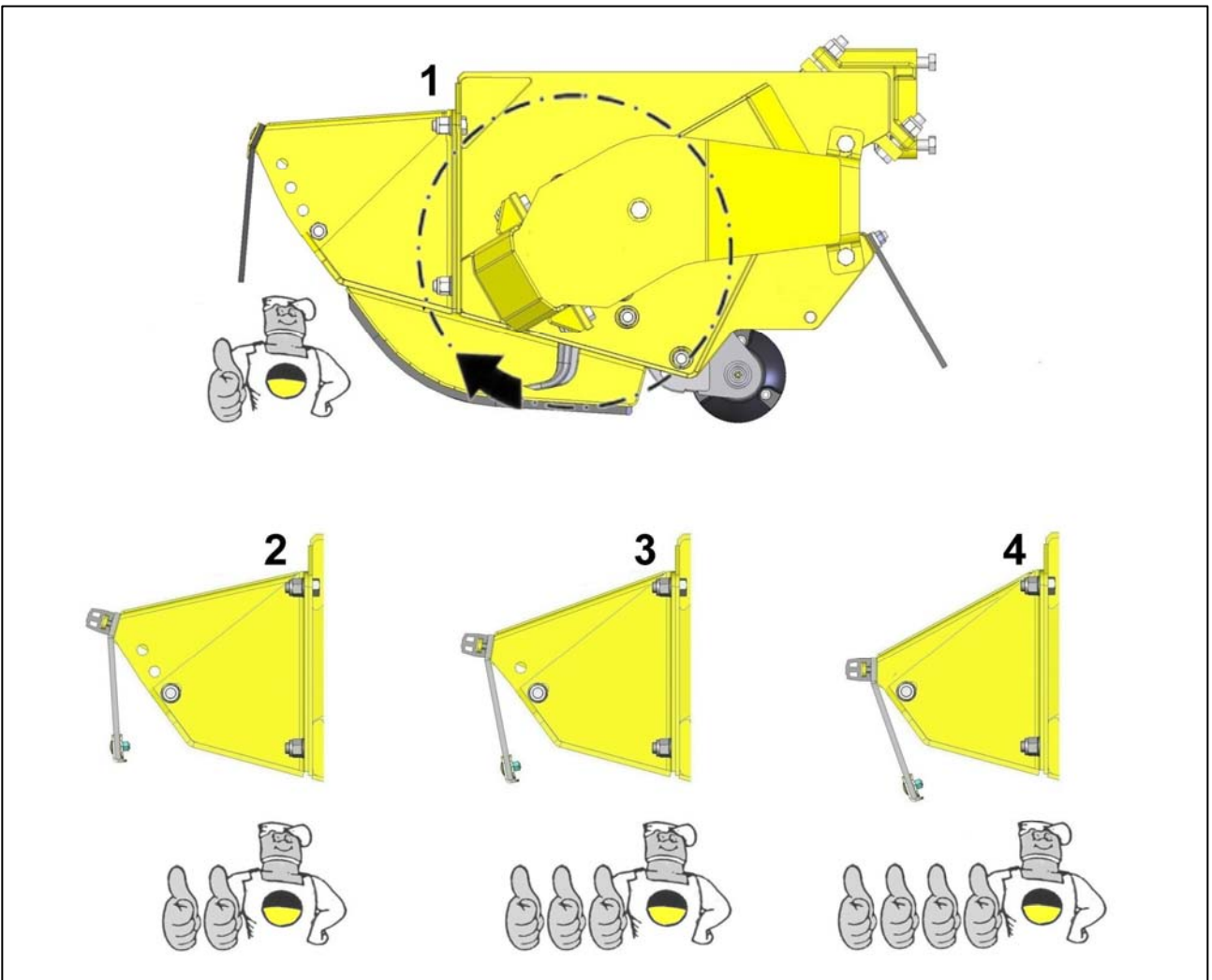

CAUTION

Before attempting grass mowing ensure the flail head is set up correctly.

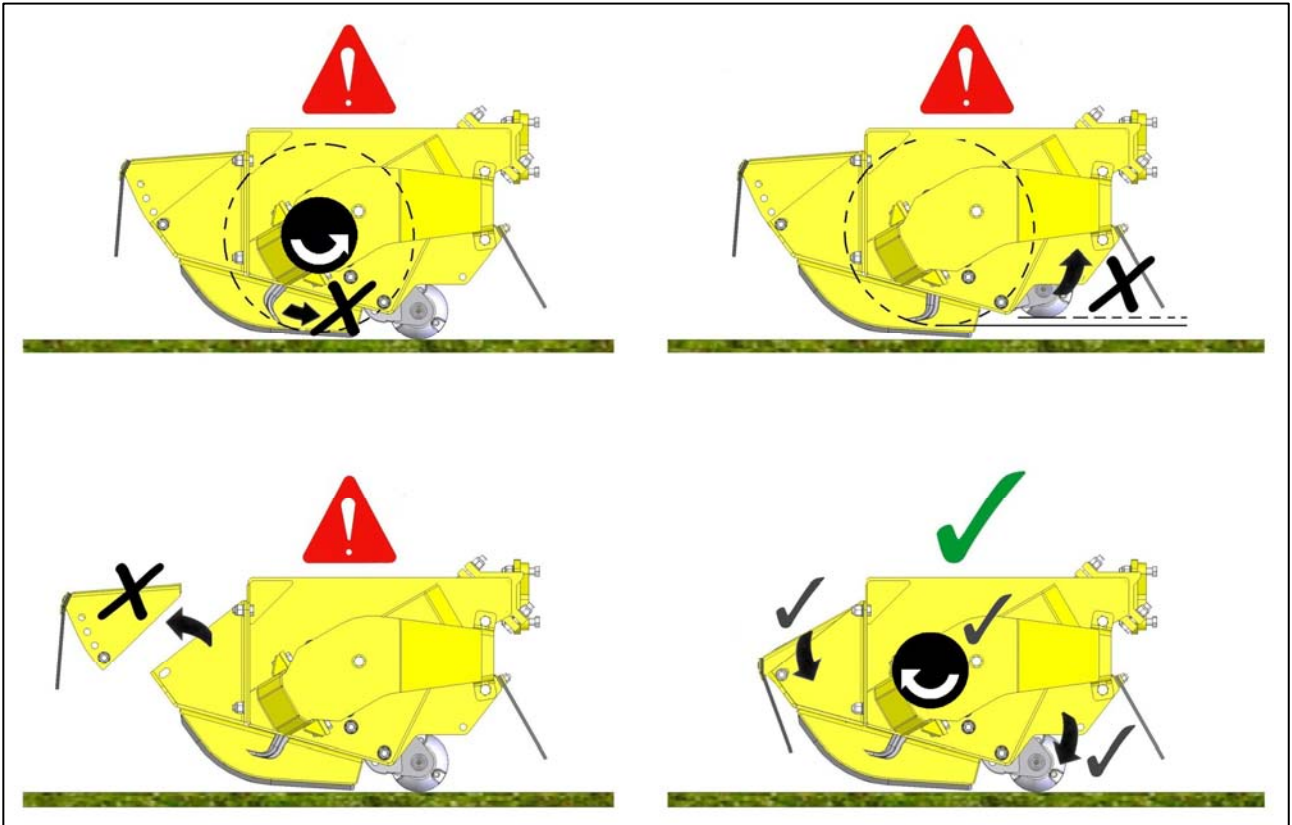

TRACTOR FORWARD SPEED

The material being cut determines tractor forward speed. Forward speed can be as fast as that which allows the flail head sufficient time to cut the vegetation properly. Too fast a speed will be indicated by over frequent operation of the breakaway system, a fall off in tractor engine revs and a poor finish to the work leaving ragged uncut tufts and poorly mulched cuttings.

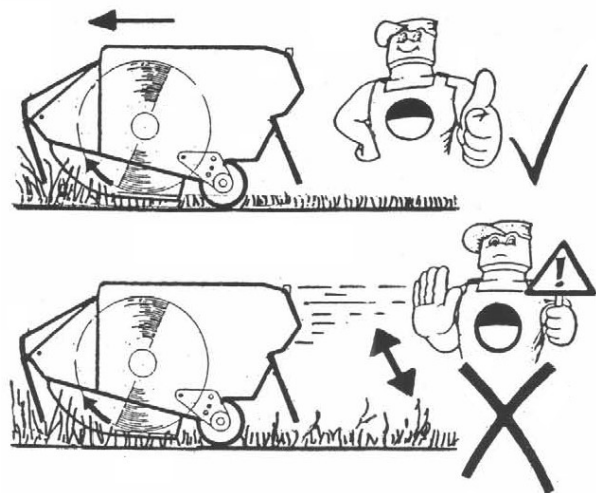

Front Hood - Verge Mowing

For verge mowing a front hood and front flap kit must be fitted and adjusted to a height that will minimise the distance materials and/or unspecified objects can be accidentally ejected. Skid kit, rear roller and rear flap must also be fitted for all mowing duties.

Hood/Flap Height Setting

To reduce the distance that objects can be ejected from the machine during work, the front hood and flaps should be set at the lowest possible setting that will still allow the work materials to efficiently enter the head but should not be above the recommended maximum height.

The recommended maximum height is calculated as follows; at a forward distance of 2 metres from the flail/material contact point, the line of sight of the flail tips, *beneath the front flaps*, should not be visible above a height of 0.5m. Refer to illustrations below.

Maximum Hood/Flap Height for Verge Mowing

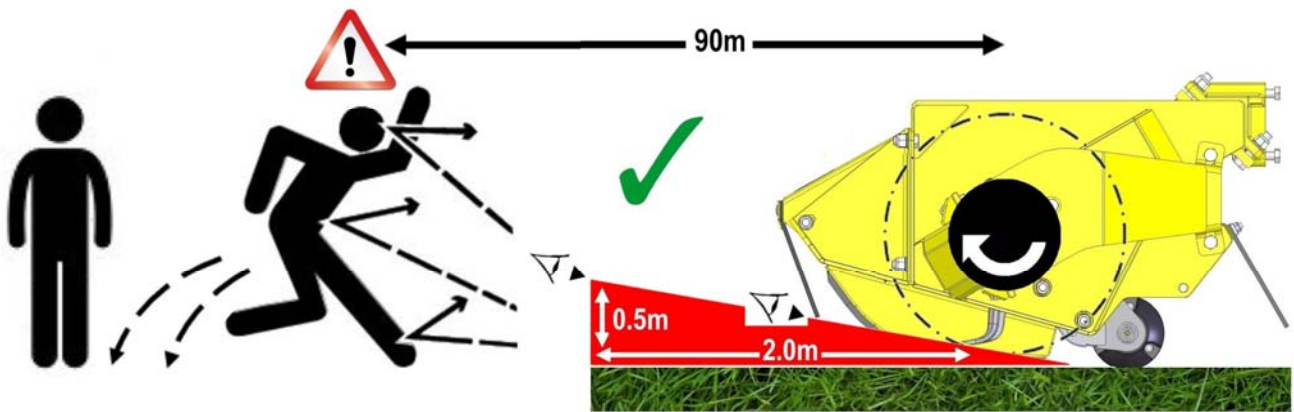

Unsuitable Hood/Flap Height for Verge Mowing

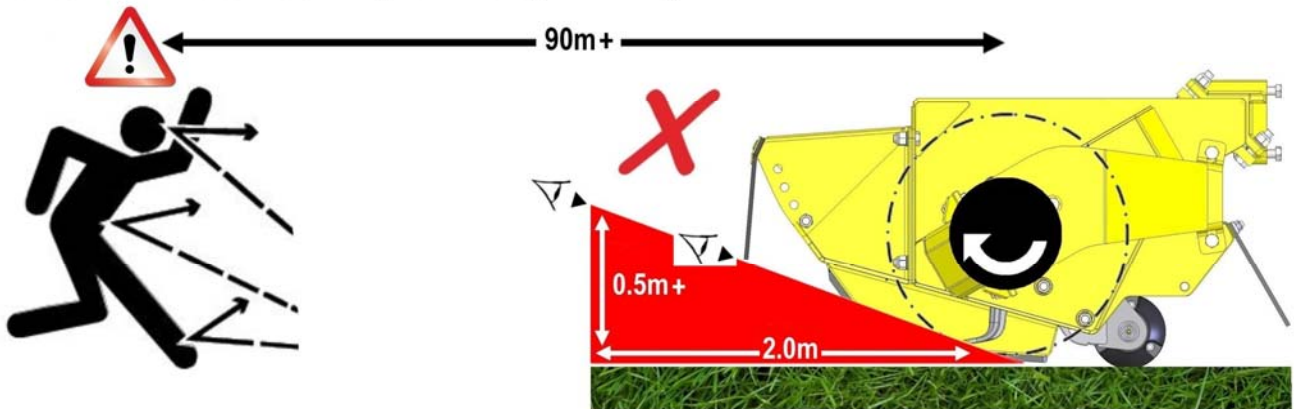

Ensure all flaps are in good condition; excessively worn, damaged or missing flaps must be replaced immediately before use.

Danger Zone – Verge Mowing / Mowing in Public Areas

For verge mowing and mowing duties in public places the front hood and flap must be positioned at the specified recommended height for verge mowing. If persons or animals come within 100m of the working machine, forward travel must be halted immediately and the rotor switched off; operations must not be resumed until they are clear of the danger zone. Caution must be adopted at all times when working in these types of areas as the operator's vision of the danger zone can be interrupted by corners and obstacles.

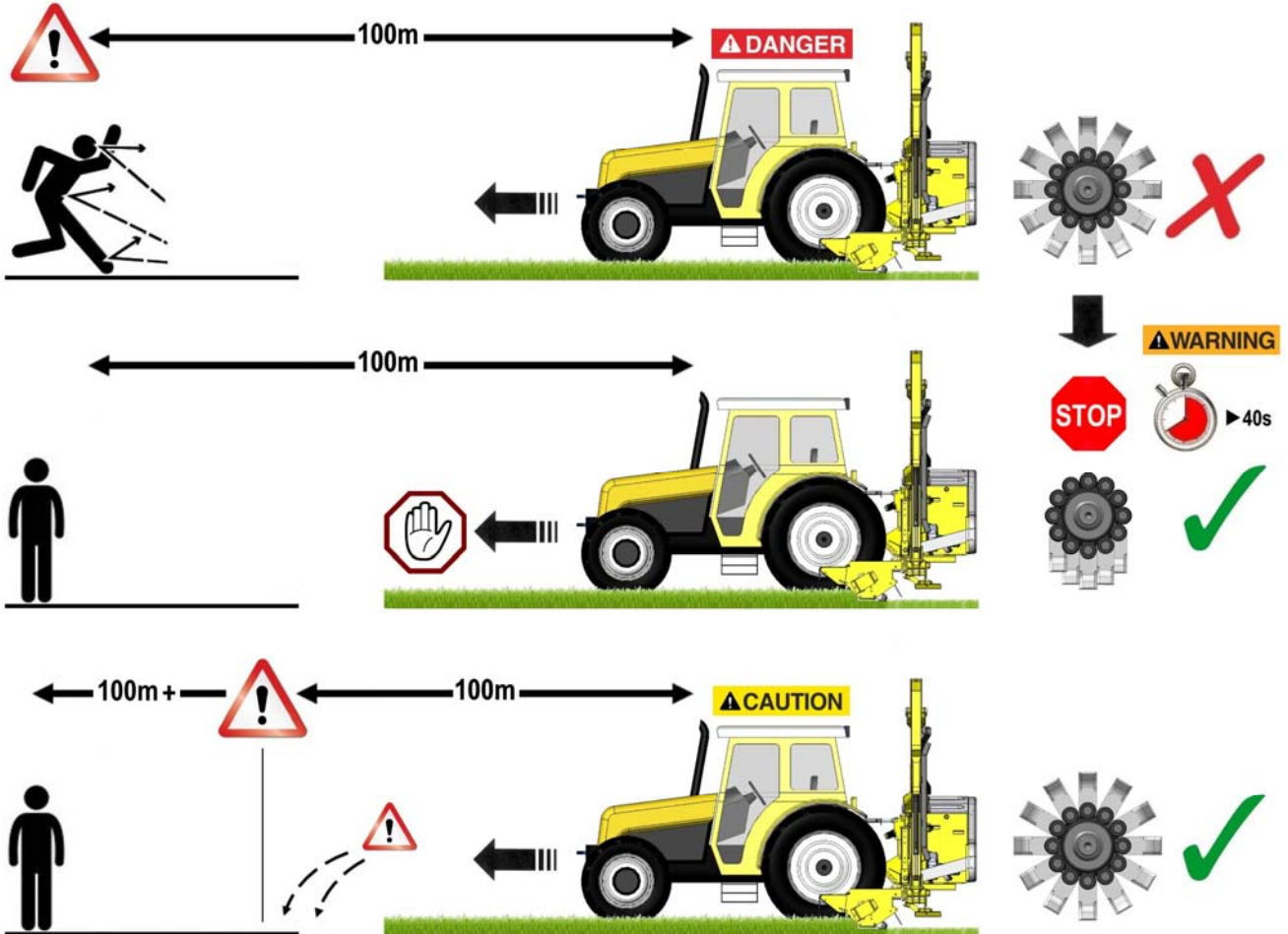

⚠ DANGER

Forward travel and rotor operation must be halted immediately when persons and/or animals are within 100m of the working machine.

FLAILHEAD ARRANGEMENT - HEDGE CUTTING (Standard Duty)

Roller Height

The roller position must always be set above the level of the rotor in positions 1 - *refer to roller positions page.*

Rotor Direction

For the best finish the rotor should cut with an upwards rotation.

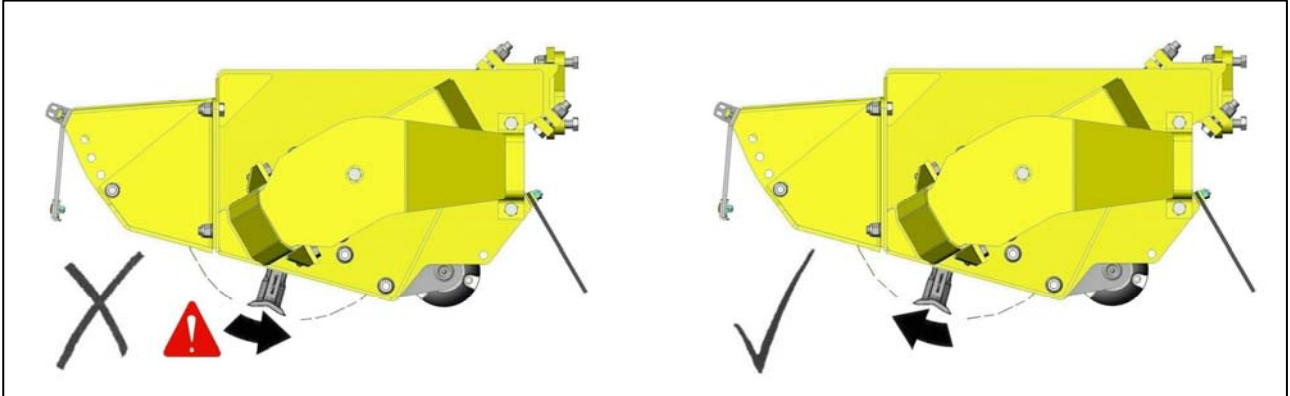

Front Hood

On universal heads the front rubber flaps, and skids if fitted, may be removed to aid the entry of the material to be cut into the flail head.

The front hood has 4 adjustment positions for height – the lowest possible position which allows the material to be cut to enter the head should always be used.

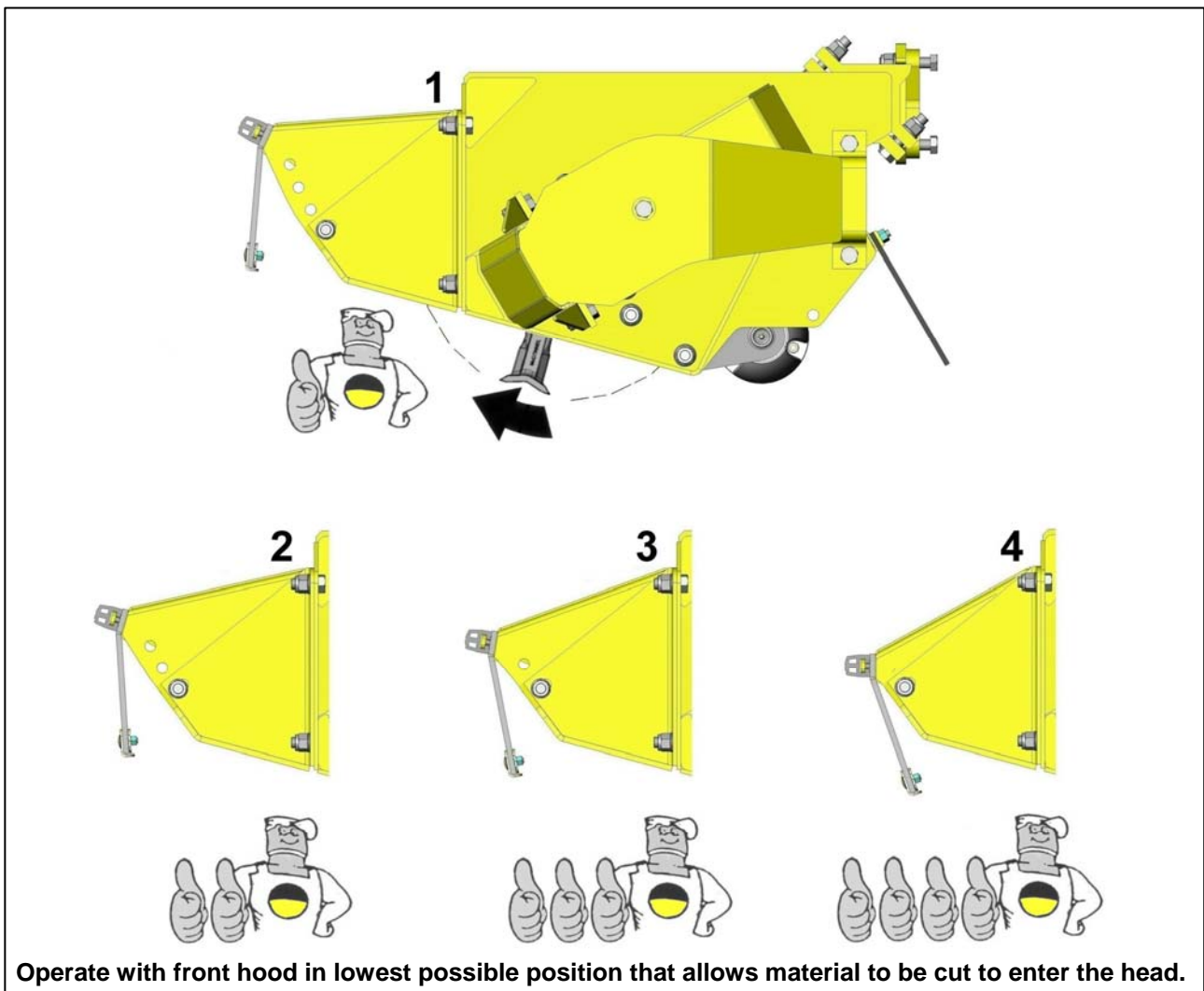

CAUTION

Before attempting hedge cutting ensure the flail head is set up correctly.

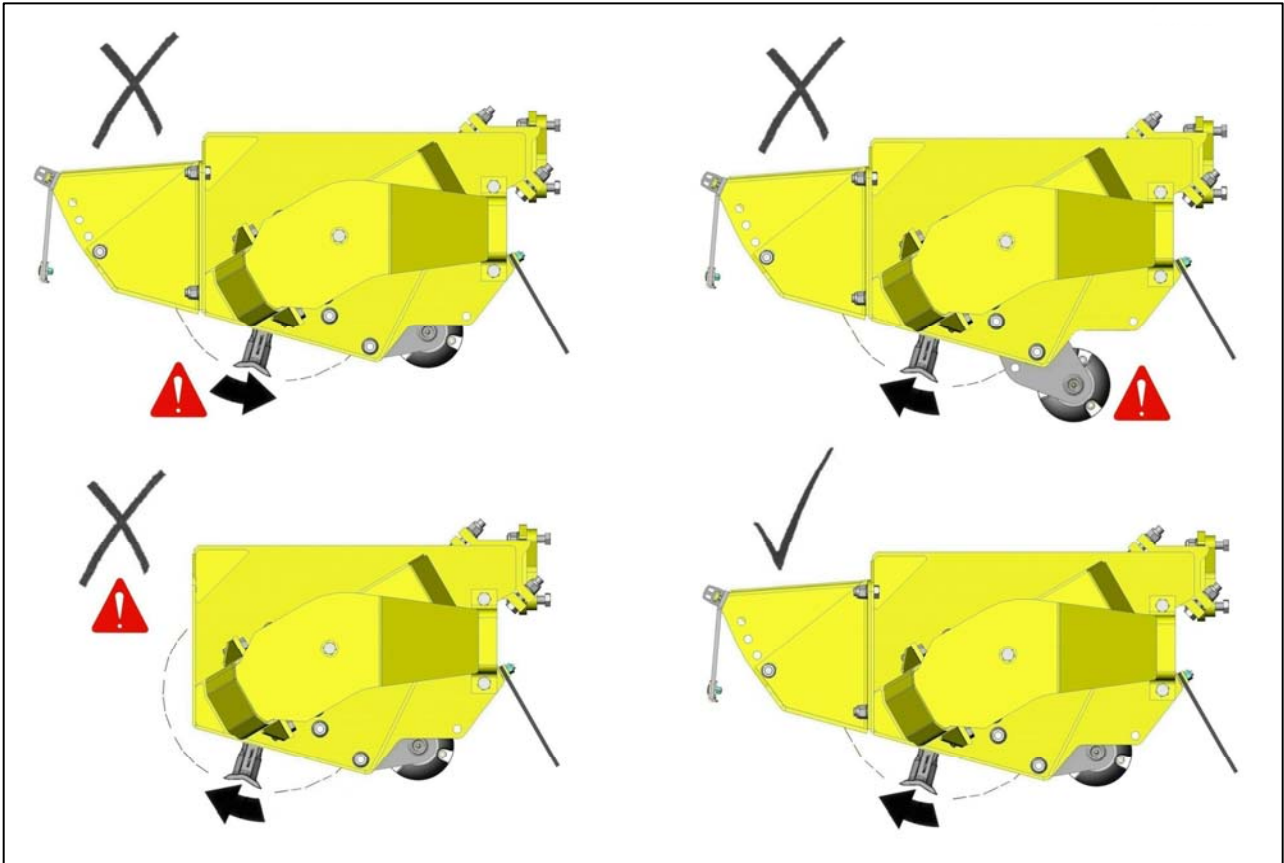

FLAILHEAD ARRANGEMENT - HEDGE CUTTING (Heavy Duty)

Roller Height

The roller position must always be set above the level of the rotor in positions 1 - refer to roller position page.

Rotor Direction

Where the size and density of material to be cut makes it necessary for the front hood and carrier plates to be removed to allow the rotor to cut, the rotor must always cut in a downwards rotation. It must be noted that this will result in a poorer finish to the work and will require more power than upward cutting.

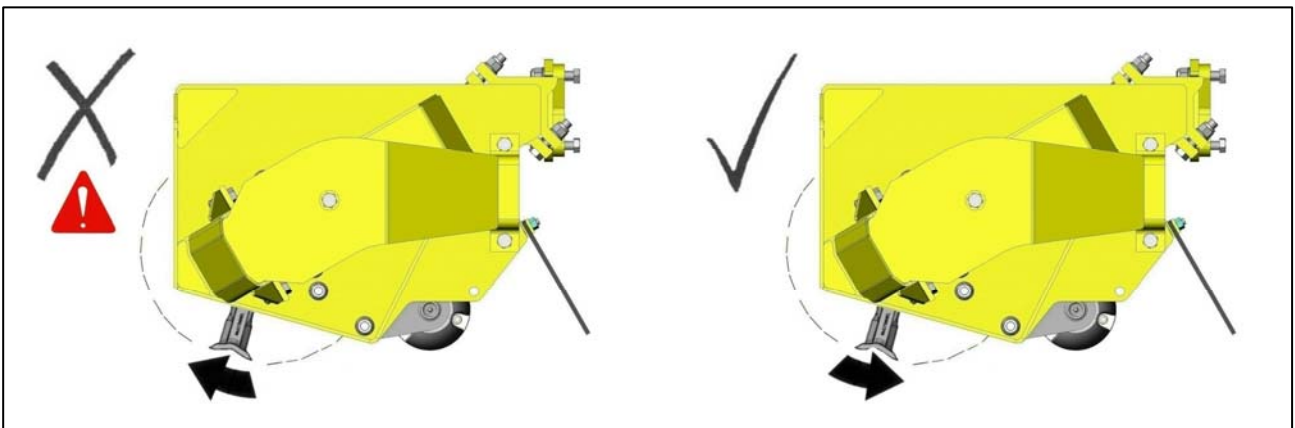

HEDGE CUTTING PROCEDURE



⚠ WARNING

Never cut on the blind side of the hedge

It is impossible to see potential hazards or dangers and the position of the flail head may allow debris to be propelled through the hedge towards the tractor and the operator.



Cut the side and bottom of the field side first. This leaves the maximum thickness of hedge on the road side to prevent the possibility of debris being thrown through the hedge into the path of oncoming vehicles.

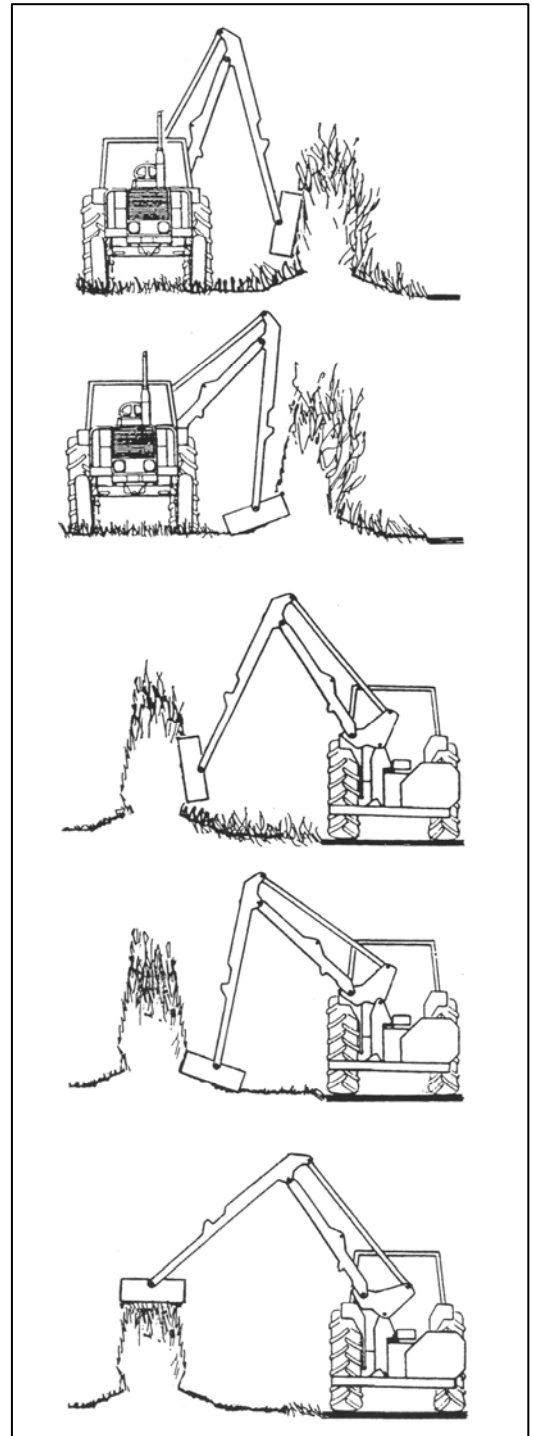

Cut the side and bottom of the road side.

Top cut the hedge to the height required.

⚠ DANGER

Never approach or attempt to inspect a flailhead whilst it is running – switch off the machine and tractor and remove the key – wait for the rotor to come to a standstill before approaching.

Frequently inspect the rotor assembly for damaged or missing flails. Bolts and nuts that secure the flails to the rotor should be regularly checked and kept tight. The correct torque setting for these locknuts is 203 Nm (150 lbf/ft.). Use only the correct flail bolt and locking nut. Check the flail pivot bushes for possible damage or wear – *they do not require oiling.*

Never attempt to run the rotor with flails missing – imbalance will cause severe vibration and can rapidly damage the rotor shaft bearings. As an emergency measure only, where a flail is broken off or missing the removal of another from the opposite side of the rotor will help to retain the balance of the rotor until the flails can be replaced – *this should be at the earliest possible opportunity.* Always replace flails in opposite pairs and never match up a new flail with a re-sharpened one – *the latter would be lighter.*





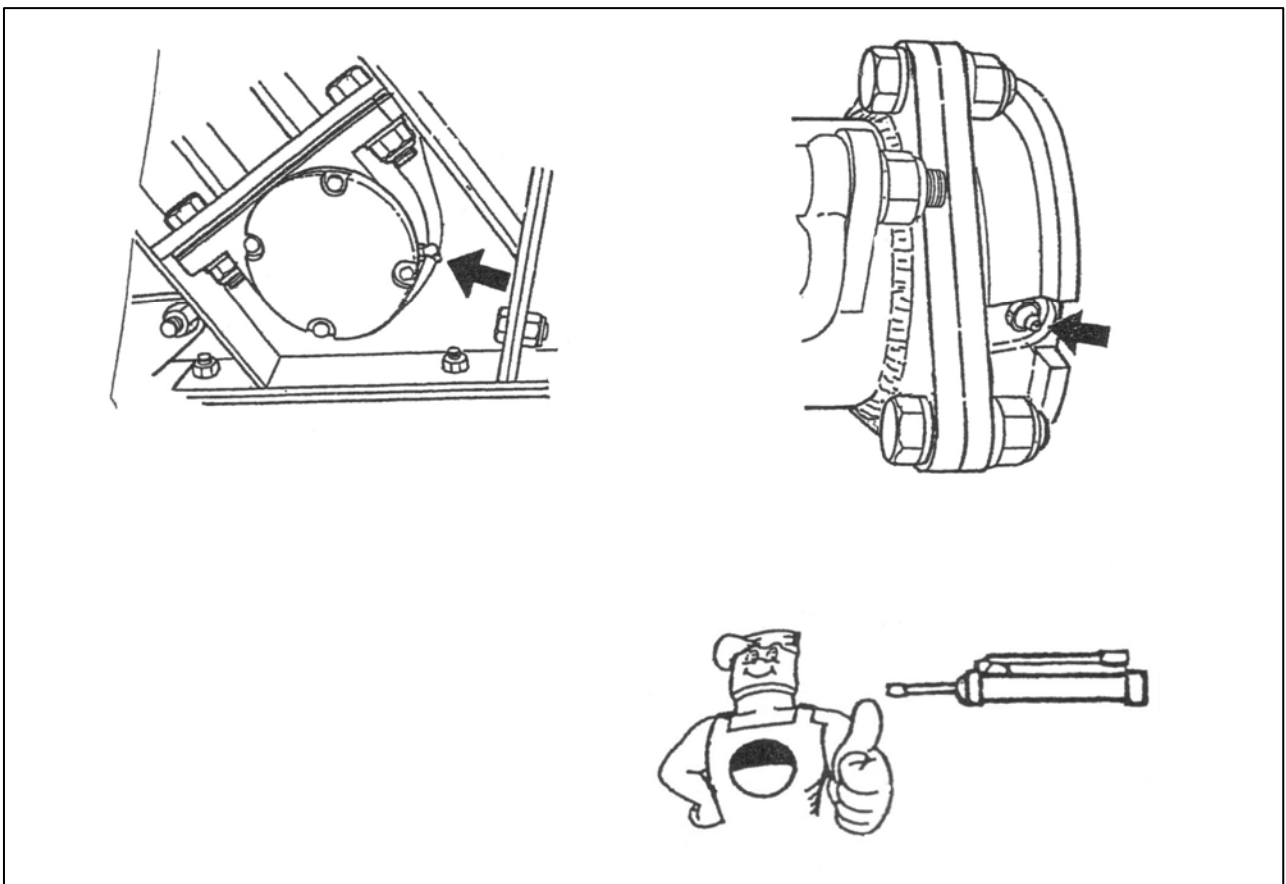

Blunt flails absorb a lot of power and leave an untidy finish to the work – *they should be sharpened periodically on a grindstone or with a portable grinder, always wear protective gear when sharpening flails.*

Ensure that the bearing housings and hydraulic mounting nuts and bolts are kept tight at all times – *they should be checked during servicing and when performing maintenance.*

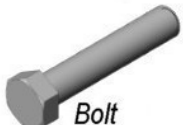

FLAIL IDENTIFICATION

The Illustrations below show the various flails and fixings and their specific part numbers.

<p>F10 D.E. Cast Flail (Part No. 7314366D)</p>	<p>F10 D.E. Forged Flail (Part No. 41391.02)</p>
<p>HEDGE</p>	<p>HEDGE</p>
<p>FIXINGS</p> <p>← Bolt: 7314201 →</p> <p>← Bush: 7314223 →</p> <p>← Washer: 0100206 →</p> <p>← Locknut: 0141006 →</p>	
<p>F10 S.E. Cast Flail (Part No. 7390276)</p>	<p>F16 D.E. Cast Flail (Part No. 21904.02)</p>
<p>HEDGE</p>	<p>HEDGE</p>
<p>FIXINGS</p> <p>← Bolt: 7314201 →</p> <p>← Bush: 7314223 →</p> <p>← Washer: 0100206 →</p> <p>← Locknut: 0141006 →</p>	
<p>D.E. Omega Flail (Part No. T1840572)</p>	<p>F14 D.E. Cast Flail (Part No. 21904.05)</p>
<p>HEDGE</p>	<p>HEDGE</p>
<p><i>Omega Rotor use only</i></p>	<p>FIXINGS</p> <p>← Bolt: 7390006 →</p> <p>← Bolt: 7314201 →</p> <p>← Bush: 21215.02 →</p> <p>← Bush: 7314223 →</p> <p>← Washer: 0100206 →</p> <p>← Locknut: 0141006 →</p>
<p>F10 Grass Flail (Part No. 7190315)</p>	<p>Forged Boot Flail (Part No. 7190462)</p>
<p>GRASS</p>	<p>UNIVERSAL</p>
<p>FIXINGS</p> <p>← Bolt: 7314201 →</p> <p>← Bush: 21215.02 →</p> <p>← Bush: 7314223 →</p> <p>← Spacer: 7190010 →</p> <p>← Spacer: 7190172 →</p> <p>← Shackle: 7190175 →</p> <p>← Washer: 0100206 →</p> <p>← Locknut: 0141006 →</p>	
 <p>Bolt</p>	 <p>Washer</p>
 <p>Bush</p>	 <p>Spacer</p>
 <p>Shackle</p>	 <p>Locknut</p>

MAINTENANCE

Frequently inspect the rotor assembly for damaged or missing flails – Never operate or attempt to run the rotor with flails missing, imbalance will cause severe vibration and can rapidly damage the rotor shaft bearings. As an emergency measure, if a flail is broken off or missing, removal of an opposing flail on the opposite side of the rotor will retain the balance. Replace the flails at the earliest possible opportunity and always replace in opposite pairs. Never match up a new flail with a sharpened or damaged flail as the latter will be lighter thus causing imbalance of the rotor.

Blunt flails absorb more power and leave an untidy finish to the work. They should be sharpened on a grindstone or with a portable grinder periodically. Always wear protective gear when sharpening flails.

Check on a regular basis, prior to operation that all bolts are tight and that torque figures are correct – refer to pre-operational check page details.

Lubrication

Grease daily the points indicated in the illustration below.

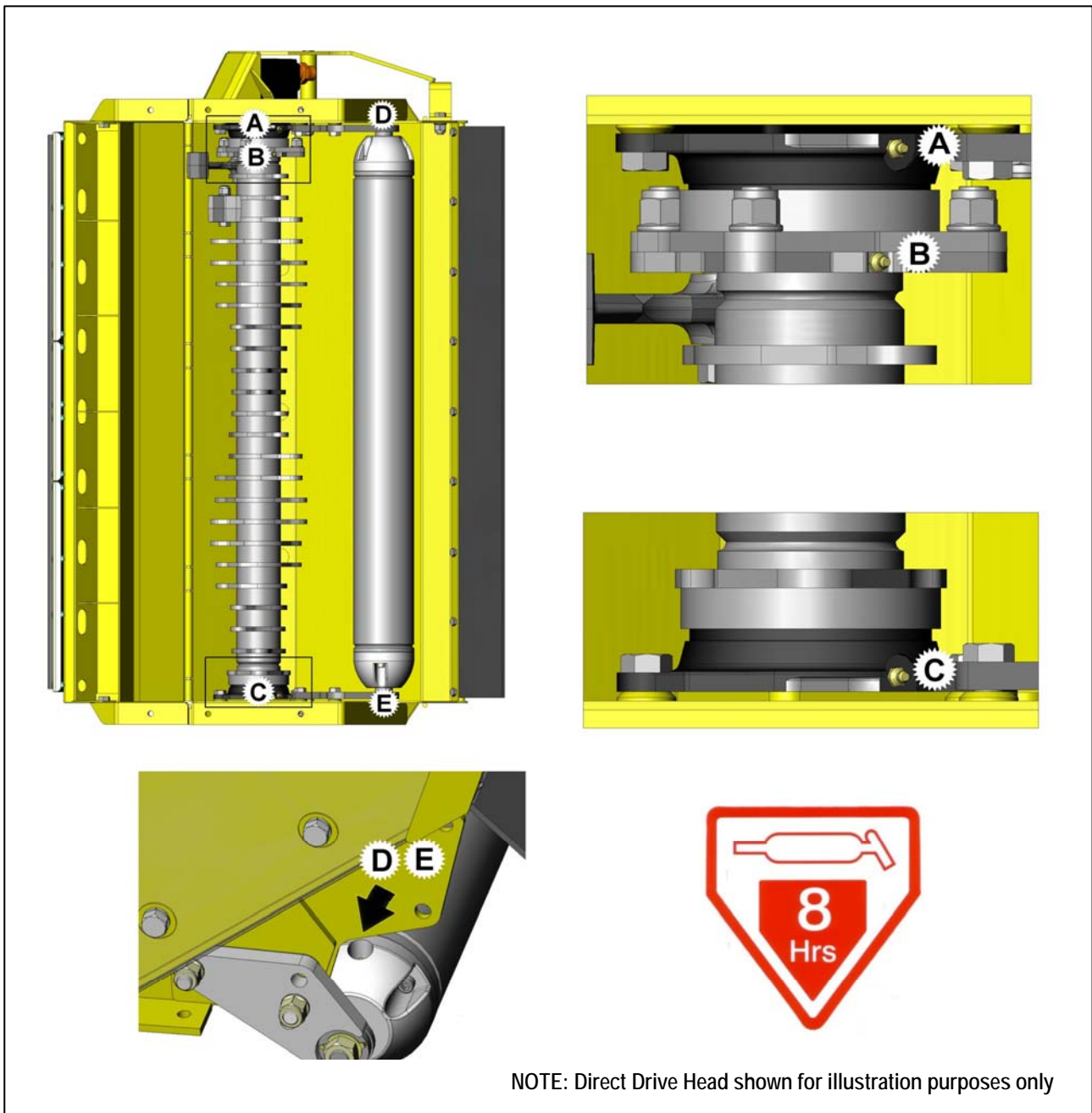

Bearing Support Lubrication

The bearing support unit has 2 lubrication points; these are located on the bearing housing and on the end of the drive spline. The bearing housing must be greased every 40 hours and the spline end every 100 hours. On early builds, access to the spline end lubrication point required removal of the belt cover; later builds are fitted with a removable plug located in the belt cover that allows quick and easy access to the lubrication point.

Remove belt cover for access to spline end lubrication point

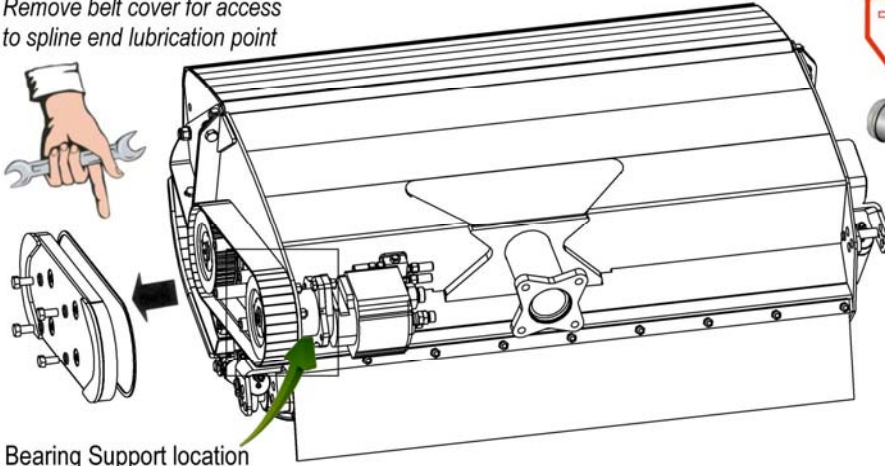

Lubrication Points & Frequency

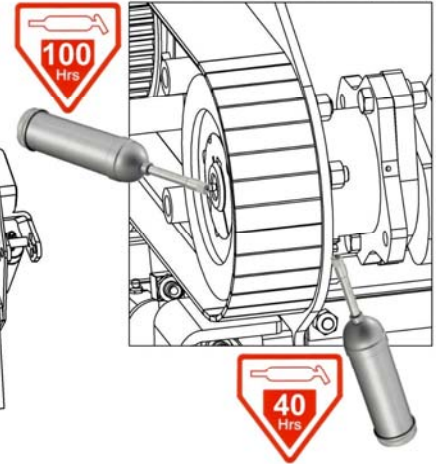

Spline End Lubrication Point Access on Later Builds

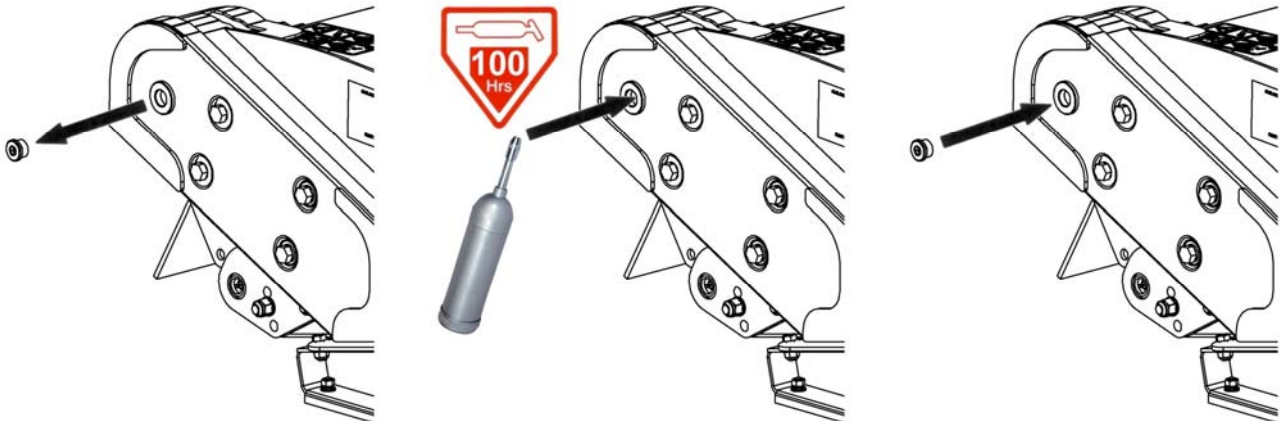

CAUTION

Ensure the access plug is replaced and tightened after lubrication of the spline end to prevent dust, grit and debris from entering the drive assembly.

ROTOR SHAFT ALIGNMENT

Rotor shaft hub failure can usually be attributed to rotor misalignment caused by distortion of the flailhead due to the hood or casing receiving a violent blow against an obstruction during work or by dropping the flail head heavily to the ground. These actions should, wherever possible, be avoided.

Where rotor alignment is incorrect or when refitting or replacing rotor components it is imperative that the following procedure for re-assembly is adhered to:

Procedure for re-assembly is as follows:-

1. Press the new bearing fully into the housing and then press the complete assembly onto the rotor shaft until the bearing inner race is firmly against the rotor shoulder.
2. Support the head off the ground in a vertical position. Offer up the complete rotor shaft into the casing, and locate the lower mounting bolts. Tighten the nuts sufficiently to take out all movement and then check the hole alignment at the top end of the casing. If the mounting bolts will not readily fit into place, release the lower bolts and shim between the casing boss and bearing housing until the top holes are aligned.
3. Locate the three top mounting bolts and then tighten the three lower bolts and nuts completely – *torque to a setting of approximately 162Nm (120 ft-lb.)*.
4. Check for clearance between the top bearing housing and casing, and completely shim all gaps before tightening the three mounting bolts to the same torque as above. If there is not clearance between the housing and casing, the bosses will need to be 'ground off' in order to provide clearance for the adding of shims. *Failure to shim all gaps will tend to draw the bearing from the shaft when the bolts are tightened.*

Note

Two sizes of shim are available from McConnel; these are:

Part No. 8121043 for 0.4mm (.015")

Part No. 8121044 for 0.6mm (.025")

Alternatively thin spacing washers .2 may be used. The welded bosses in the casing may be of varying depths - this is a jiggling requirement during manufacture of the head and should not be regarded as a fault.

5. Finally, with the flail head horizontal, turn the rotor over by hand. There should be no binding or tight spots. Replace motor but do not bolt in place, when the rotor is rotated by hand the motor should not move. Movement up and down or side to side indicates a problem.

Warning: Failure to correctly align the rotor shaft may result in the motor shaft breaking.

6. The Coupling should be fitted on to the Motor and the nut tightened to a maximum torque setting of 80Nm (60 ft-lb.) - Do not exceed this value. Prior to the fitting of the motor, the hub and coupling splines should be liberally coated with Morris's K65MS high temperature grease, or equivalent. Experience has indicated that in addition to the pre-pack with Morris's K64MS grease supplied, greasing the rotor bearings, particularly the drive side, twice daily can considerably improve the longevity of the drive hub and coupling.

Rotor Shaft Shim Fitment

Rotor mis-aligned

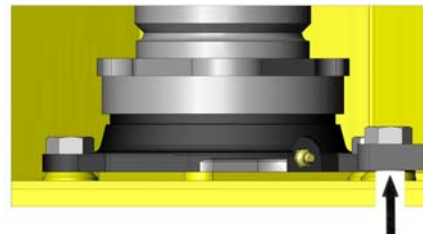
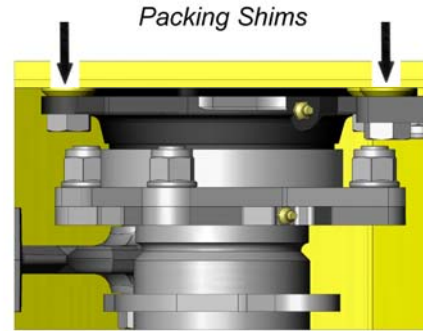
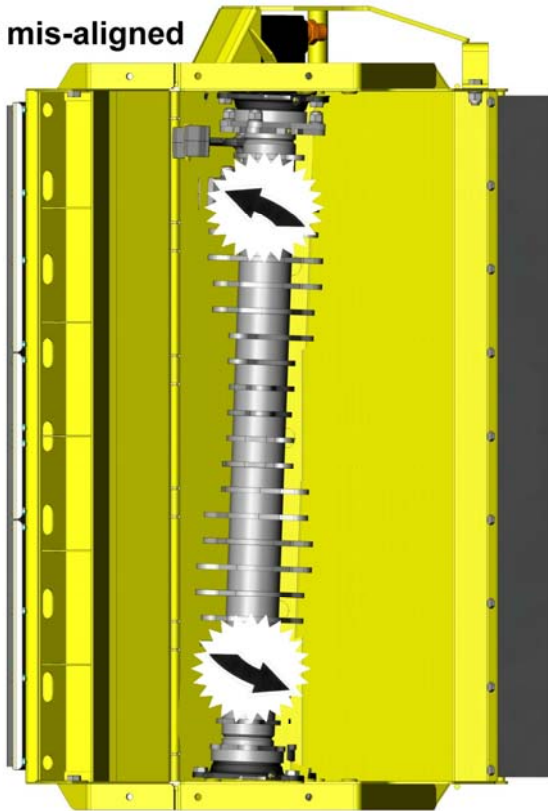

Shim where required to adjust alignment

Rotor aligned

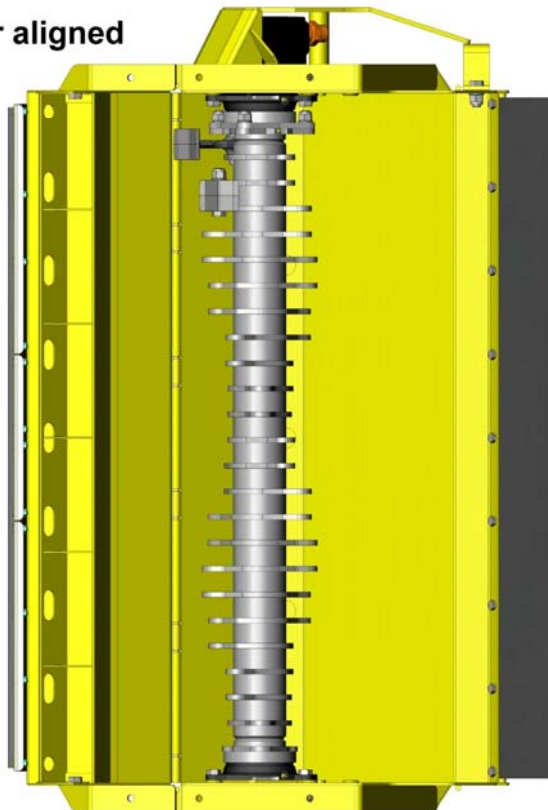

NOTE: Direct Drive Head shown for illustration purposes only

BELT DRIVE FLAILHEAD – ALIGNMENT PROCEDURE

Belt pulleys must be correctly aligned at all times to avoid excessive belt wear or damage. Alignment of the pulleys is achieved by the use of shims placed between the rotor's free end bearing housing and its mounting position on the casing assembly; adding or removing shims allows angular adjustment of the rotor shaft and pulley so it can be correctly aligned with the motor drive pulley. Shims are available in 2mm and 3mm thicknesses, the quantity used will be the number required only to achieve accurate alignment.

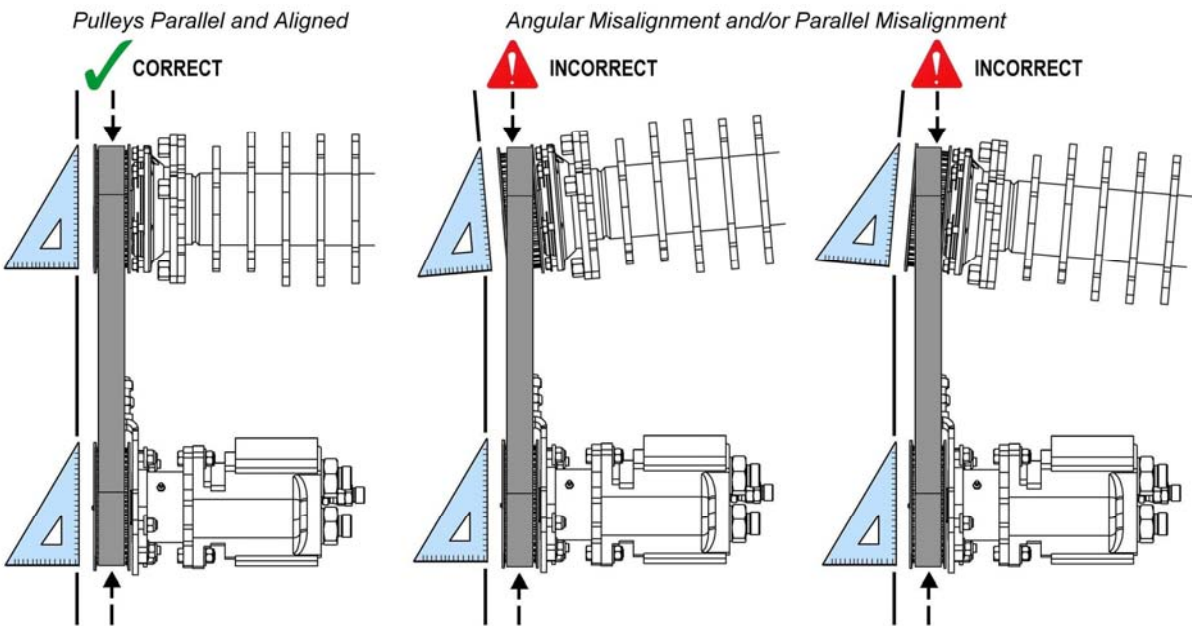
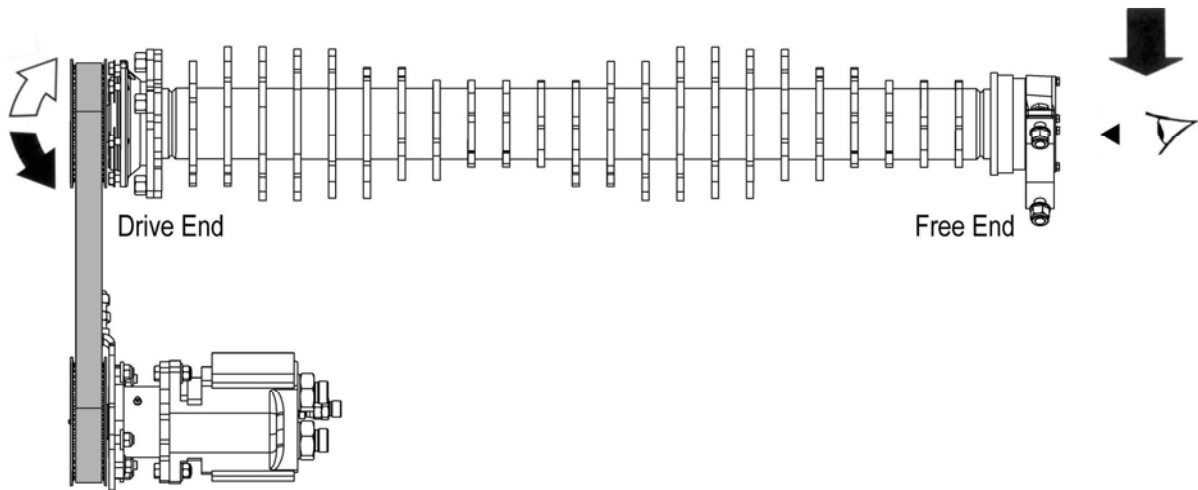
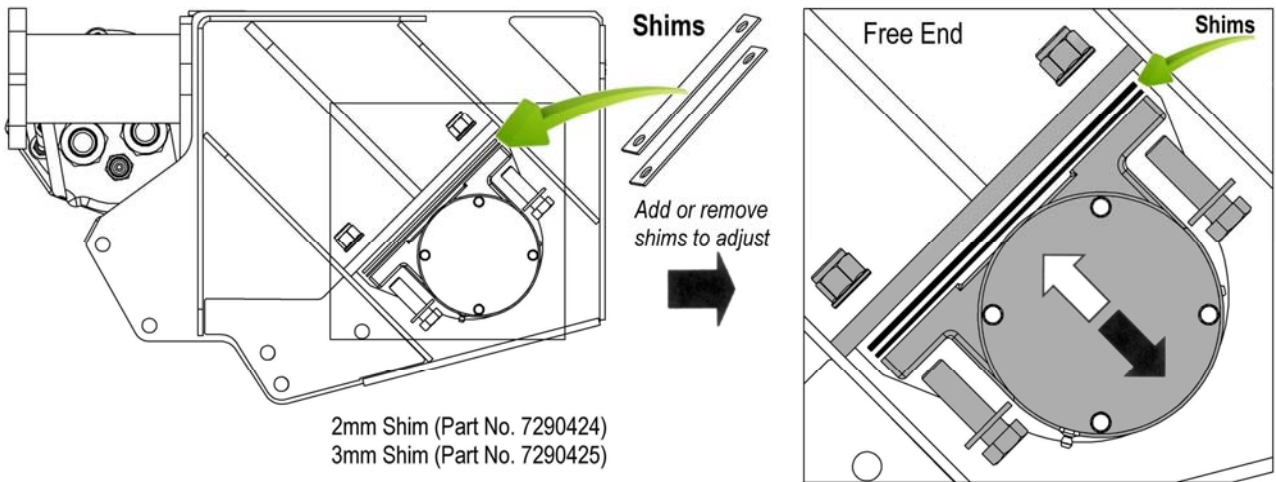

Drive Pulley

In extreme cases of pulley mis-alignment where adjustment of the rotor pulley alone does not align the pulleys correctly, additional adjustment can be made by placing shimming washers between the motor plate and the flail head casing as illustrated below.

The placement of the washers will depend on which direction adjustment is needed but will either be on the outermost pair of bolts or the innermost; in either case an equal number of washers should be used.

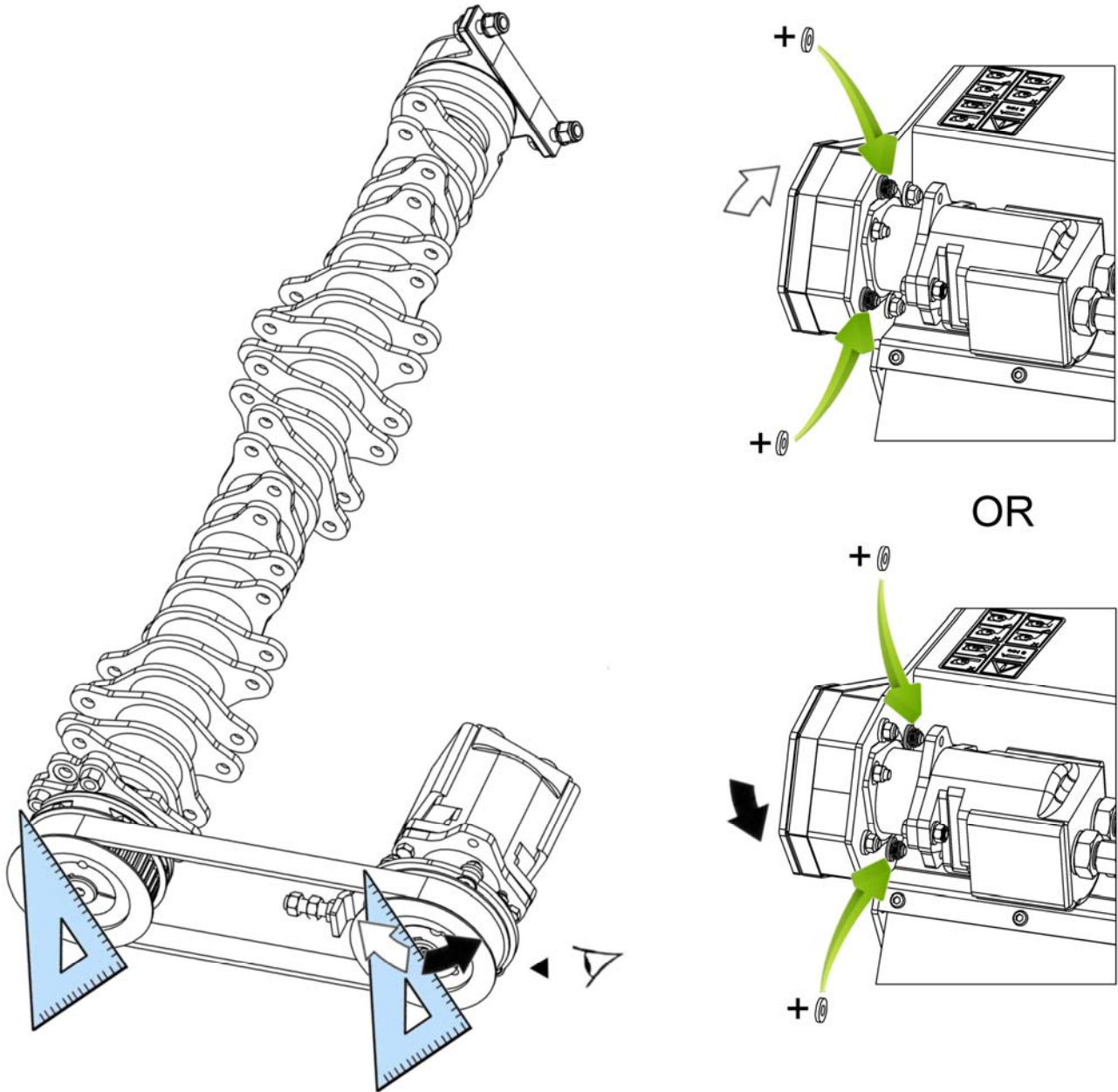

When pulleys have been correctly aligned the belt tension should be checked and if required adjusted to the correct tension; refer to belt adjustment section for details of belt tensioning procedure.



McConnel Generic Parts Manual

Generic parts manuals should be used as a general guide to the components used on the machine; to ensure accurate parts information for a specific machine please refer to the 'Interactive Parts Database' on our website which identifies the exact components used on the machine when it was manufactured based on the machine's unique serial number.

Direct access can be gained using the web address or QR code below.
<http://www.mcconnel.com/support/product-support/interactive-parts-database/>



Design improvements may have altered some of the parts listed in this manual; latest parts will always be supplied if they are interchangeable with earlier ones.

1.6M BELT DRIVE FLAILHEAD ASSEMBLY

McCONEL

Module(s): 7290953

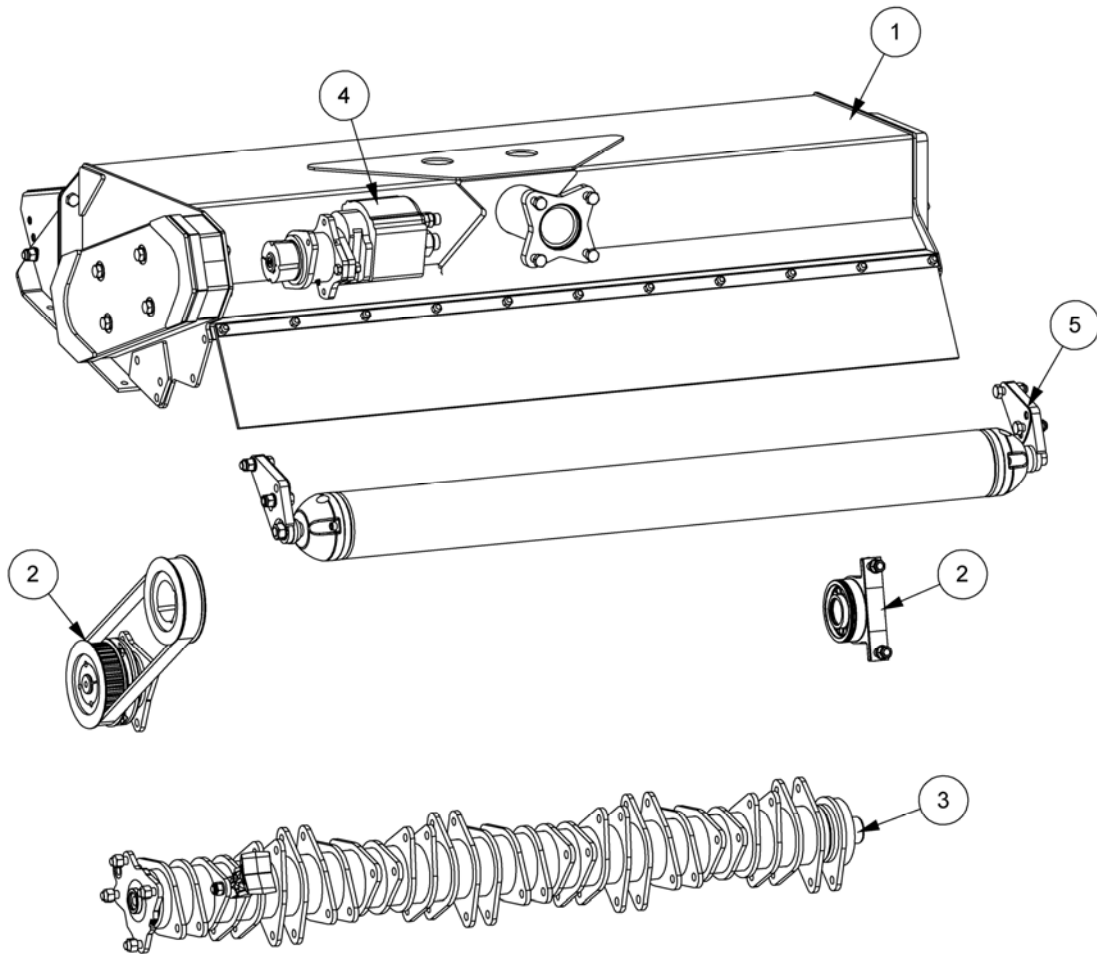

REF.	QTY.	PART No.	DESCRIPTION
		7290953	1.6M BD FLAILHEAD ASSEMBLY
1	1	7290952	CASING MODULE - 1.6m BD HEAD
2	1	22498.05	QUAD DRIVE MODULE (BELT DRIVE)
3	1	22497.24	1.6M ROTOR MODULE (F16DE FLAILS)
4	1	22495.12	HIGH POWER MOTOR MODULE (85HP)
5	1	42241.27	1.6M ROLLER ASSEMBLY

1.6M FLAILHEAD CASING ASSEMBLY (Belt Drive)

Module(s): 7290952

McCONEL

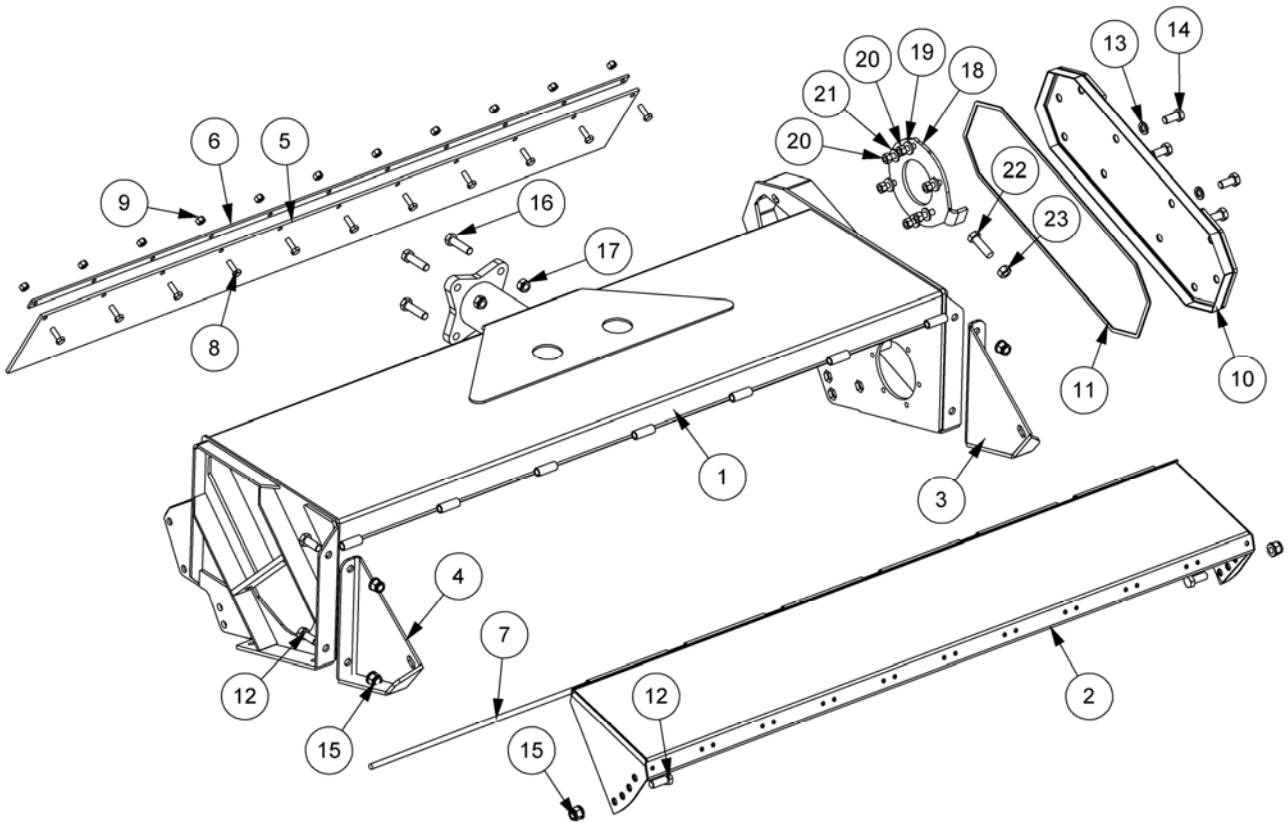

REF.	QTY.	PART No.	DESCRIPTION
		7290952	1.6M CASING ASSEMBLY (BD HEAD)
1	1	7290401	1.6M FLAIL HEAD CASING - R/H
2	1	7290403	FRONT HOOD
3	1	7290388	L/H HOOD BRACKET
4	1	7290387	R/H HOOD BRACKET
5	1	7290405	REAR FLAP
6	1	7290406	CLAMP STRIP
7	1	7290065	HOOD PIVOT BAR
8	11	9313065	SETSCREW
9	11	9143005	SELF-LOCKING NUT
10	1	7290343	DRIVE COVER
11	1	7290052	SEALING STRIP
12	6	30.073.25	BOLT
13	4	9100207	SPRING WASHER
14	4	12.714.35	BOLT
15	6	9100024	SELF-LOCKING FLANGE NUT
16	4	9200031	BOLT
17	4	9100028	SELF-LOCKING NUT
18	1	43458.08	MOTOR PLATE - R/H
19	4	7290051	CLAMP WASHER
20	6	9143006	SELF-LOCKING NUT
21	2	9100106	FLAT WASHER
22	1	9313117	SETSCREW
23	1	9113007	NUT

1.6M QUAD ROTOR ASSEMBLY

McCONEL

Module(s): 22497.22

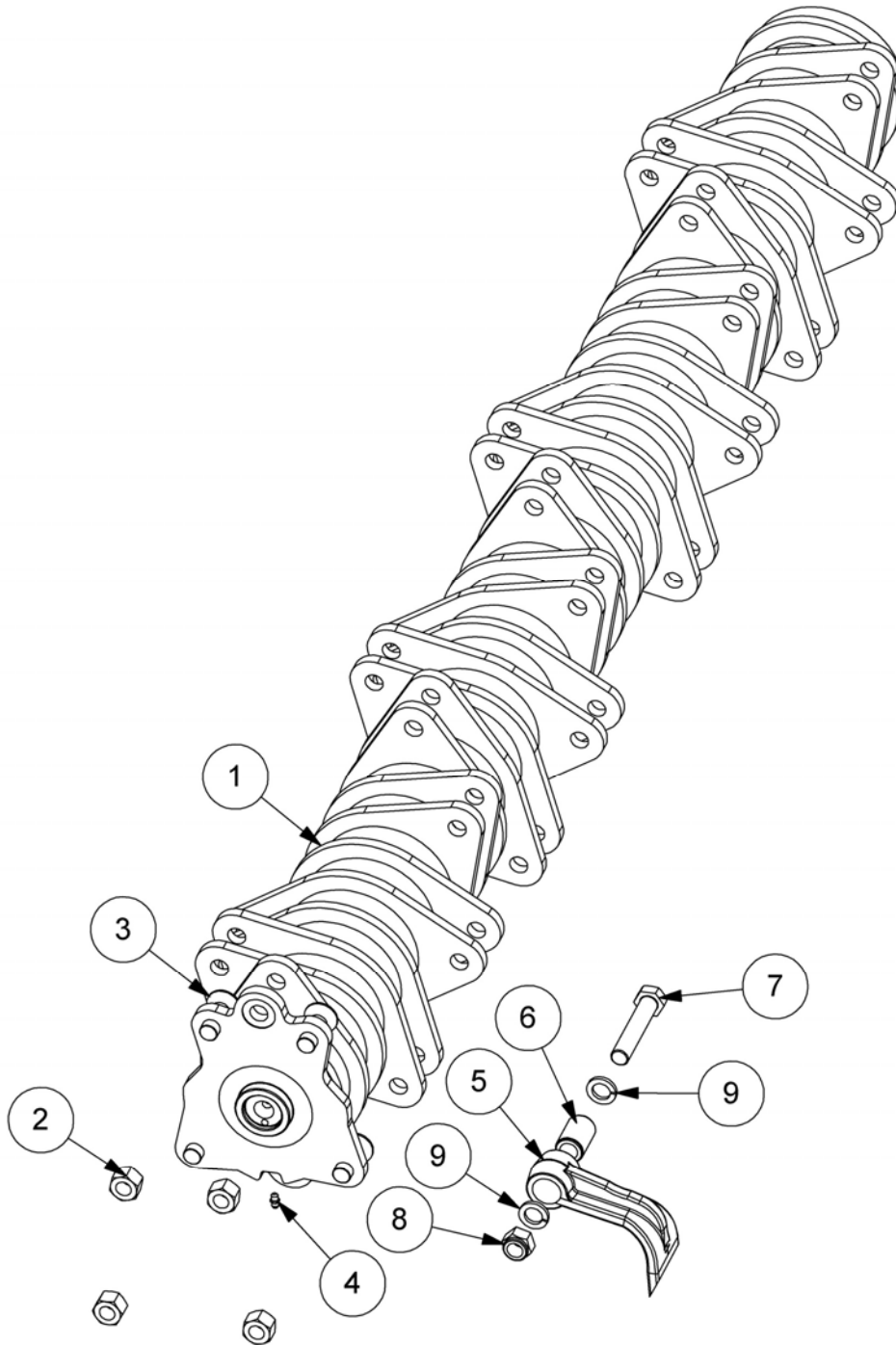

REF.	QTY.	PART No.	DESCRIPTION
		22497.22	1.6M QUAD DRIVE ROTOR MODULE
1	1	22269.06	1.6M QUAD ROTOR (WRAP ROUND)
2	4	9163007	NYLOC NUT
3	4	9353097	CAPSCREW
4	1	0901161	GREASE NIPPLE
5	32	7390276	FLAIL - SINGLE EDGED
6	32	7314223	FLAIL PIVOT BUSH (NARROW)
7	32	7314201	UNF SPECIAL BOLT
8	32	0141006	UNF CLEVELOC NUT
9	64	0100206	SPRING WASHER

1.6M ROTOR ASSEMBLY

McCONEL

Module(s): 22497.24

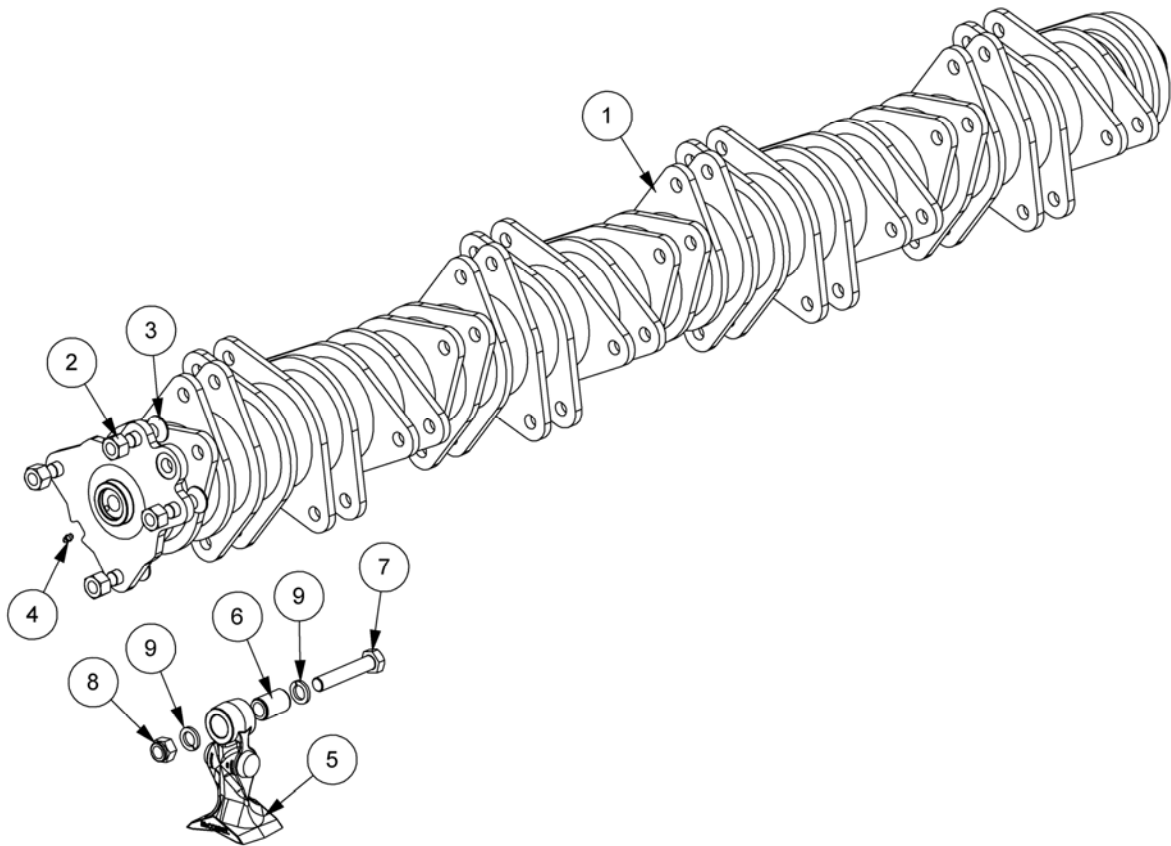

REF.	QTY.	PART No.	DESCRIPTION
		22497.24	1.6M ROTOR ASSEMBLY
1	1	22269.06	1.6M QUAD ROTOR
2	4	9143007	SELF-LOCKING NUT
3	4	9353097	CAPSCREW
4	1	0901161	GREASE NIPPLE
5	32	21904.02	CAST FLAIL (F16)
6	32	7314223	FLAIL PIVOT BUSH (NARROW)
7	32	7314201	SPECIAL BOLT
8	32	0141006	CLEVELOC NUT
9	64	0100206	SPRING WASHER

1.6M ROTOR ASSEMBLY

McCONEL

Module(s): 22497.26

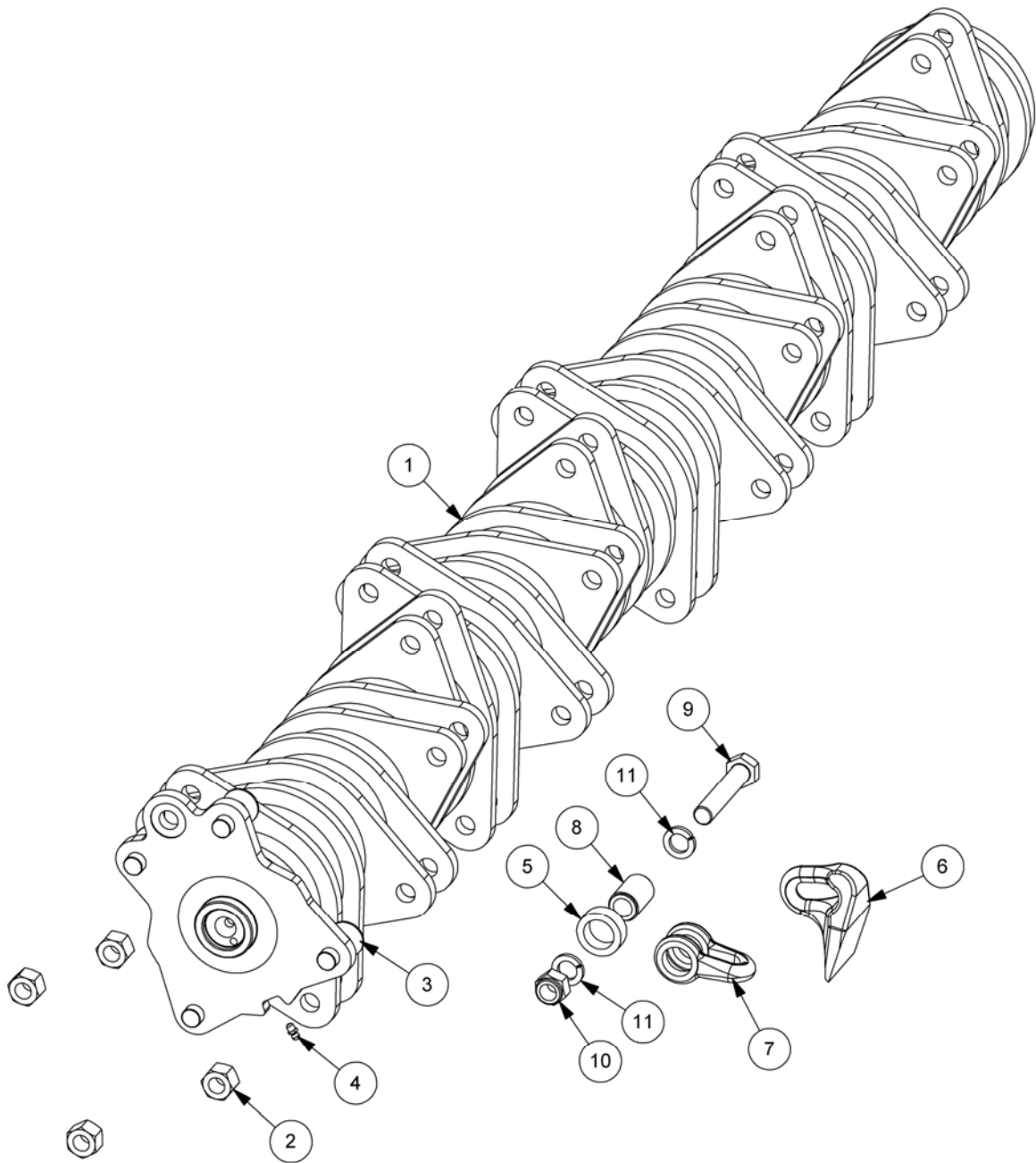

REF.	QTY.	PART No.	DESCRIPTION
		22497.26	1.6M ROTOR ASSEMBLY
1	1	22269.06	1.6M QUAD DRIVE ROTOR
2	4	9163007	NYLOC NUT
3	4	9353097	CAPSCREW
4	1	0901161	GREASE NIPPLE
5	32	7190172	SPACER
6	32	7190462	BOOT FLAIL
7	32	7190175	SHACKLE
8	32	7314223	FLAIL PIVOT BUSH (NARROW)
9	32	7314201	UNF SPECIAL BOLT
10	32	0141006	UNF CLEVELOC NUT
11	64	0100206	SPRING WASHER

1.6M ROTOR ASSEMBLY

McCONEL

Module(s): 22497.59

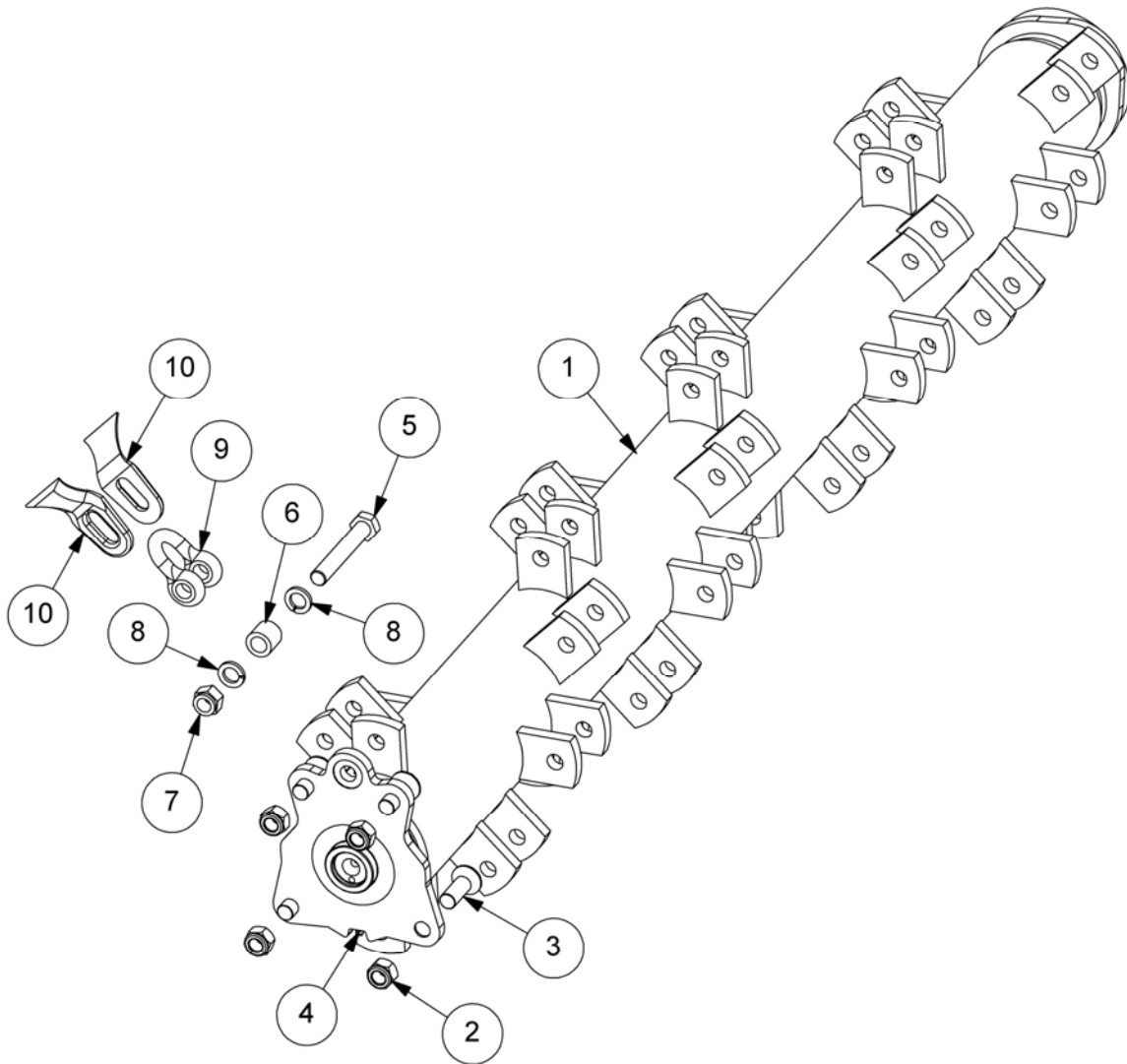

REF.	QTY.	PART No.	DESCRIPTION
		22497.59	1.6M ROTOR ASSEMBLY
1	1	22269.23	1.6M ROTOR
2	4	9163007	NYLOC NUT
3	4	9353097	SKT CSK CAPSCREW
4	1	0901161	GREASE NIPPLE
5	32	7390006	SPECIAL GRADE BOLT (UNF)
6	32	7390018	SLEEVE
7	32	0141006	CLEVELOC NUT (UNF)
8	64	0100206	SPRING WASHER
9	32	7390013	SHACKLE
10	64	41654.01	FLAIL (FLARED)

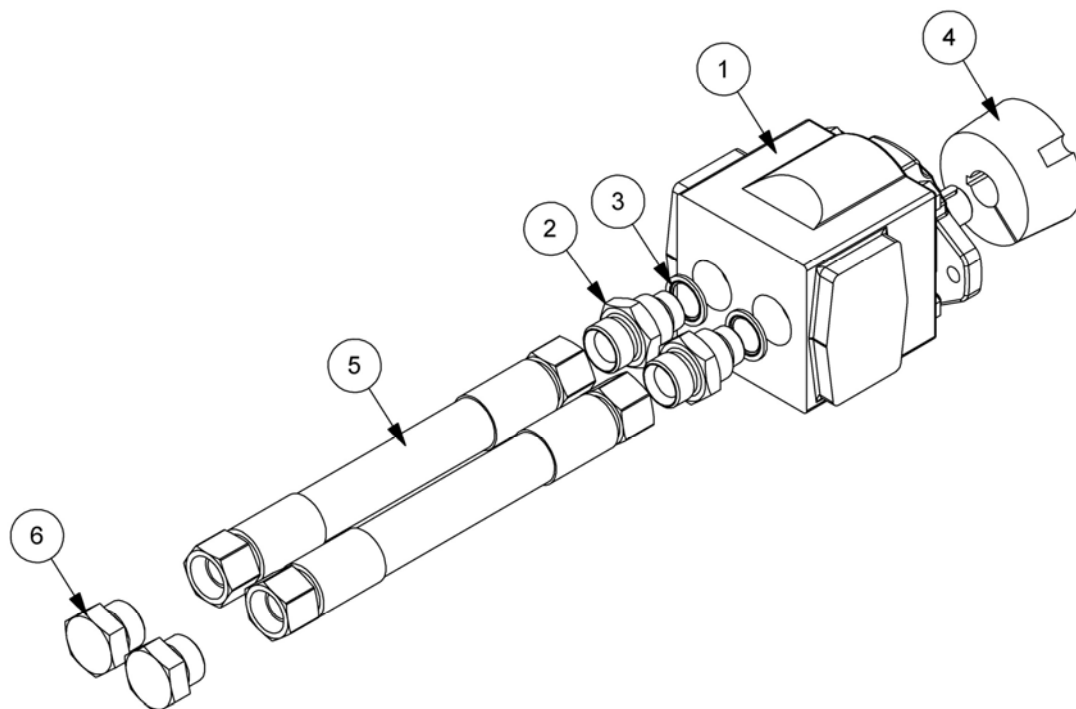

REF.	QTY.	PART No.	DESCRIPTION
		22495.34	MOTOR MODULE 65HP
1	1	09.773.04	MOTOR (65HP)
2	2	8581295	ADAPTOR
3	2	8650106	BONDED SEAL
4	1	05.424.07	TAPERLOCK
5	2	10.011.19	HOSE - 1" BSP FS/FS x 950mm
6	2	05.433.03	PLUG
7	1	7550065	HOSE SLEEVING - 508mm

PISTON MOTOR MODULE (77HP)

McCONEL

Module(s): 22495.68

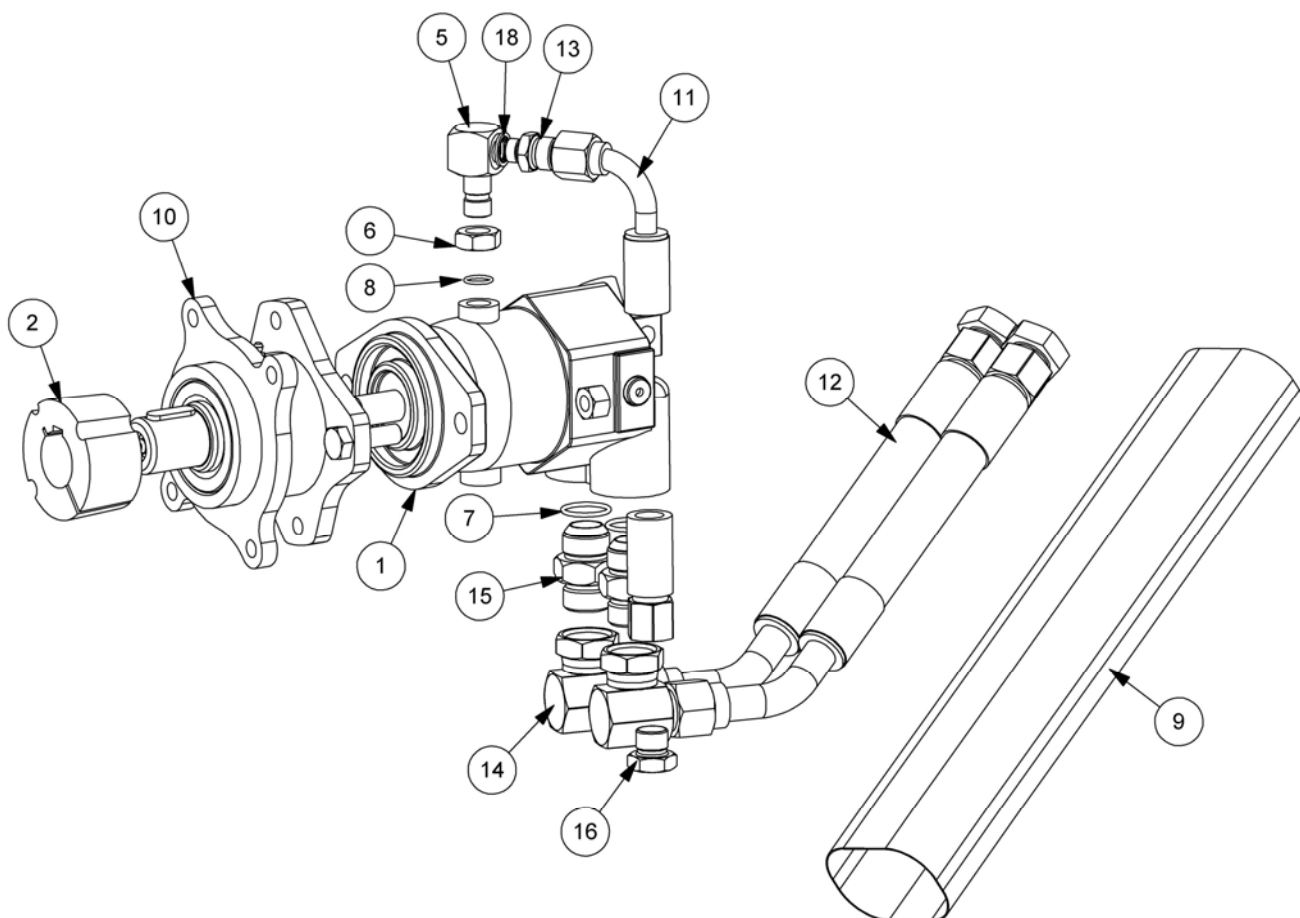

REF.	QTY.	PART No.	DESCRIPTION
		22495.68	PISTON MOTOR MODULE (BD)
1	1	8301290	PISTON MOTOR (40cc)
2	1	7290016	TAPER LOCK BUSH
3	2	05.968.06	NYLOC NUT
4	2	9200017	BOLT
5	1	42739.01	ADAPTOR ELBOW
6	1	0131007	LOCKNUT
7	2	8600916	O RING
8	1	8600908	O RING
9	1	00999588	HOSE SLEEVING
10	1	23323.04	BEARING SUPPORT
11	1	10.008.22	HOSE 5/8" BSP FS/F90 x 1200mm
12	2	8501238	HOSE 1"BSP FS/F135 x 36"
13	1	8581175	ADAPTOR
14	2	8581212	BLOCK ELBOW 90°
15	2	8581256	ADAPTOR (JIC)
16	1	8581351	BLANKING PLUG
17	2	05.433.03	PLUG
18	1	8650103	BONDED SEAL

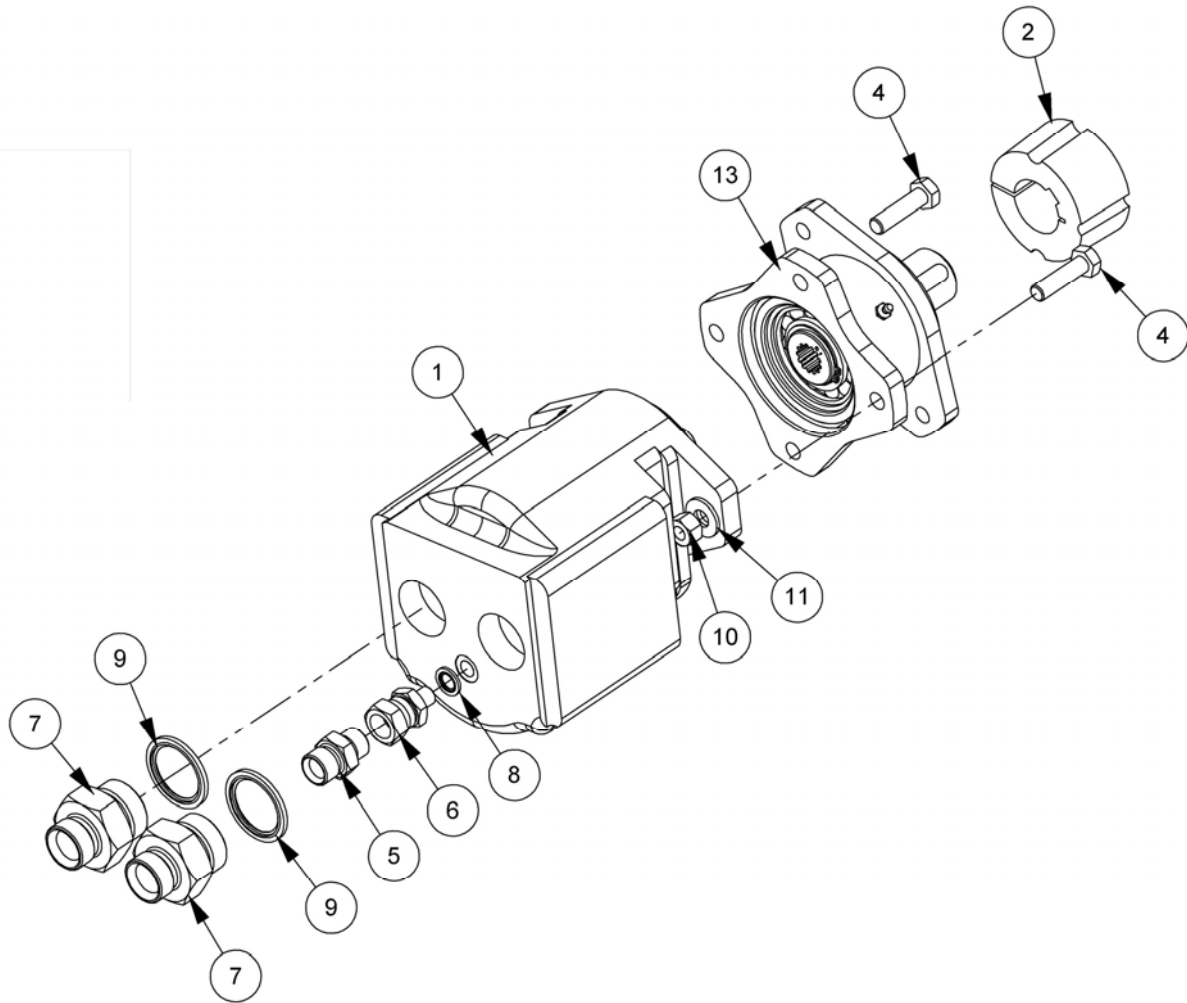

REF.	QTY.	PART No.	DESCRIPTION
		22495.12	MOTOR MODULE
1	1	8301307	HYDRAULIC MOTOR
2	1	7290016	BUSH
3	2	21270.24	* HOSE
4	2	9213096	BOLT
5	1	G3812120	ADAPTOR
6	1	EYS0035	ADAPTOR
7	2	05.131.01	ADAPTOR
8	1	8650102	SEAL
9	2	8650109	SEAL
10	2	9143006	NUT
11	1	9100106	WASHER
12	1	00999588	* HOSE SLEEVE (1400mm)
13	1	7290491	SUPPORT
14	1	10.007.24	* HOSE - 5/8" BSP FS/FS x 1400mm

* components not illustrated

8699263 MOTOR SEAL KIT

WHEN FITTING MODULE TO CASING
GREASE NIPPLE IN 23323.05 TO FACE
TO REAR OF FLAILHEAD FOR ACCESSABILITY

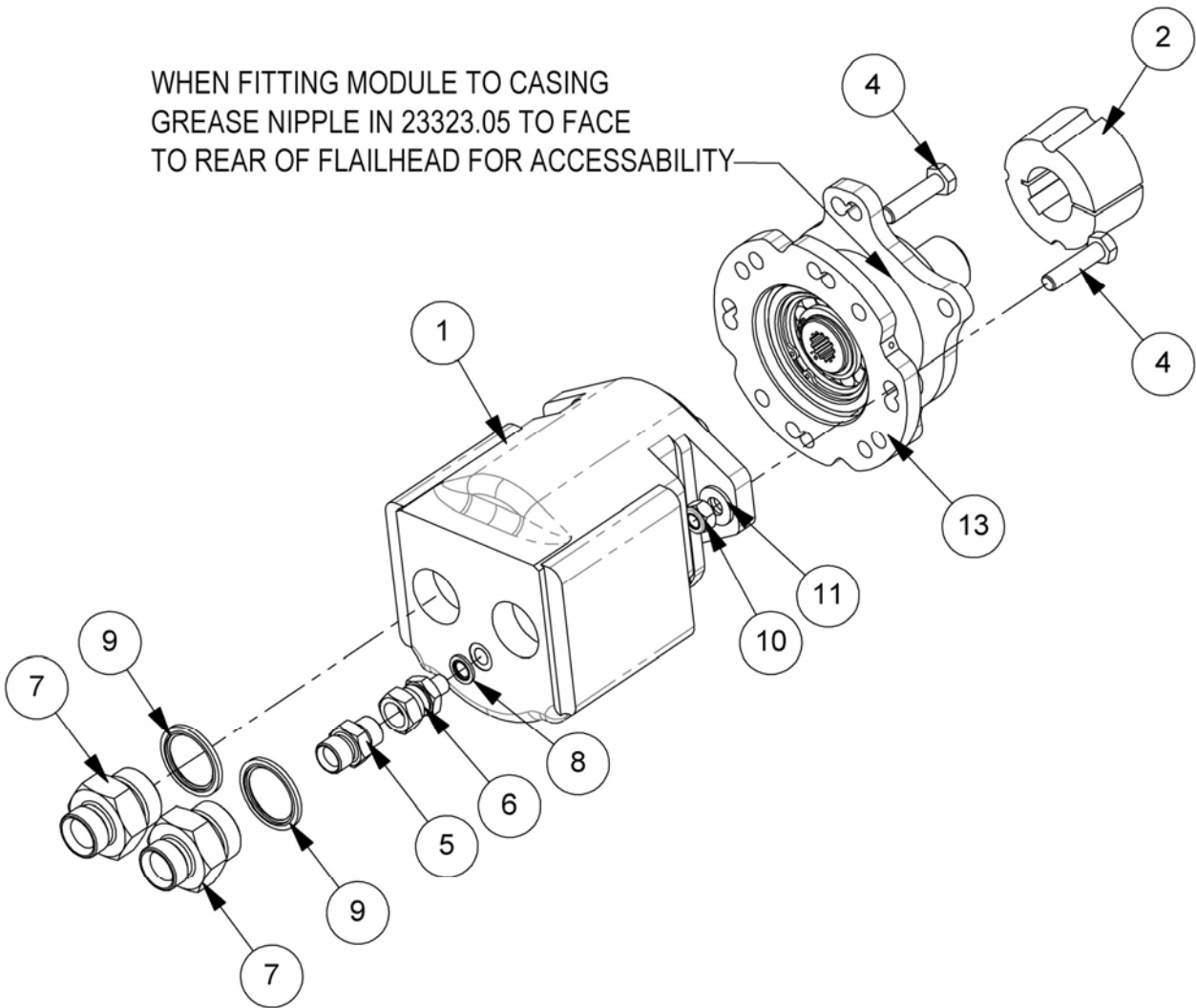

REF.	QTY.	PART No.	DESCRIPTION
		22495.67	MOTOR MODULE
1	1	8301307	HIGH PRESSURE MOTOR
2	1	7290016	TAPER LOCK BUSH
3	2	21270.24	HOSE 1"BSP FS/F135 x 1400mm
4	2	9213106	BOLT
5	1	G3812120	ADAPTOR
6	1	EYS0035	ADAPTOR
7	2	05.131.01	ADAPTOR
8	1	8650102	BONDED SEAL
9	2	8650109	BONDED SEAL
10	2	9163006	NYLOC NUT
11	4	9100106	FLAT WASHER
12	1	10.007.24	HOSE - 5/8"BSP FS/FS x 1400mm
13	1	23323.05	BEARING SUPPORT ASSEMBLY
14	1	22590.24	HOSE SLEEVING

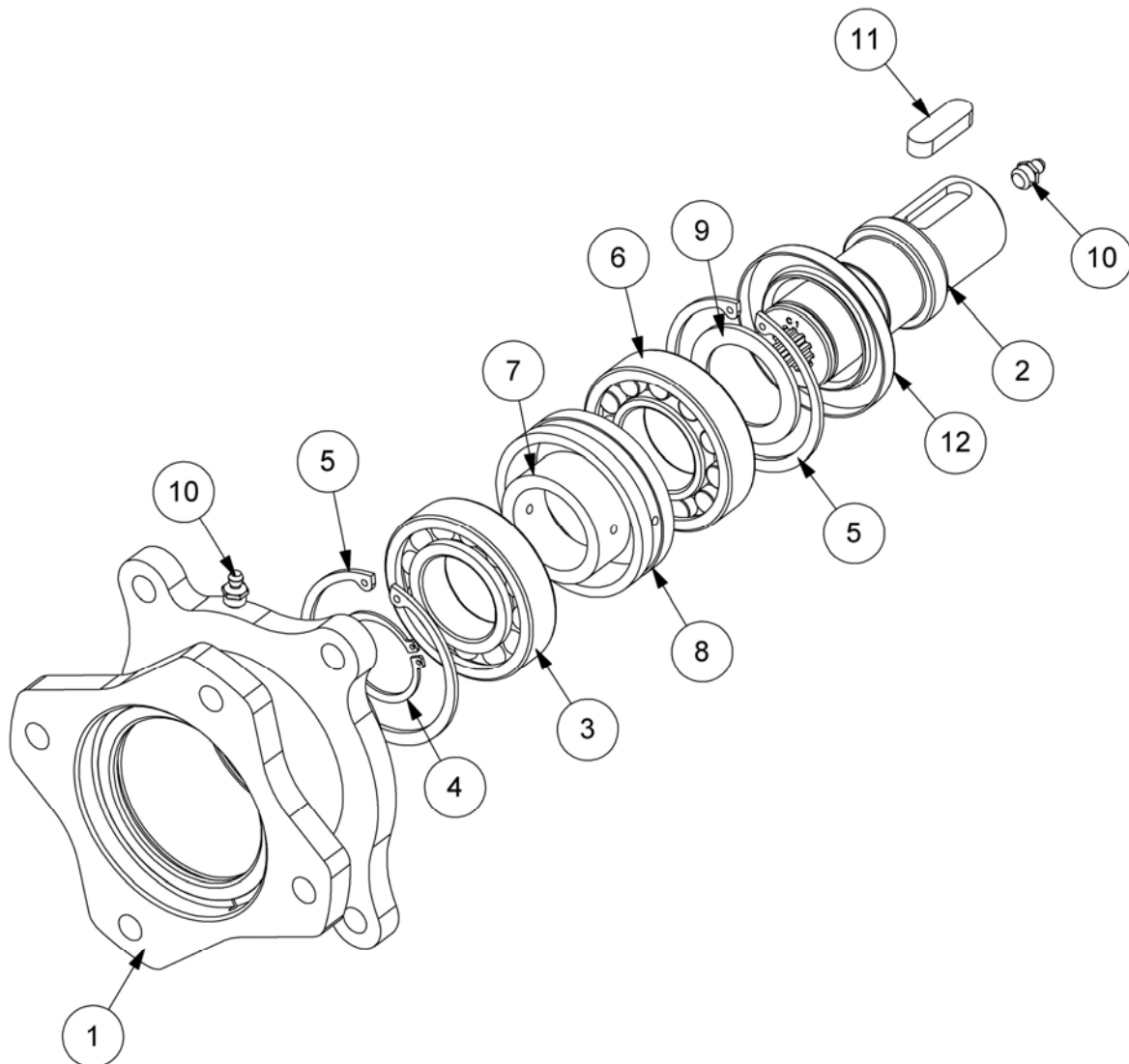

REF.	QTY.	PART No.	DESCRIPTION
		23323.04	BEARING SUPPORT ASSEMBLY
1	1	23324.04	BEARING SUPPORT
2	1	7290378	SPLINED SHAFT
3	1	0603640	BALL BEARING
4	1	0401240	EXTERNAL CIRCLIP
5	2	0416280	INTERNAL CIRCLIP
6	1	0600098	ROLLER BEARING
7	1	7290058	BEARING SPACER - INNER
8	1	7290057	BEARING SPACER - OUTER
9	1	7290059	COLLAR BEARING SUPPORT
10	2	0901121	GREASE NIPPLE
11	1	7290017	KEY
12	1	8629199	ROTARY SEAL

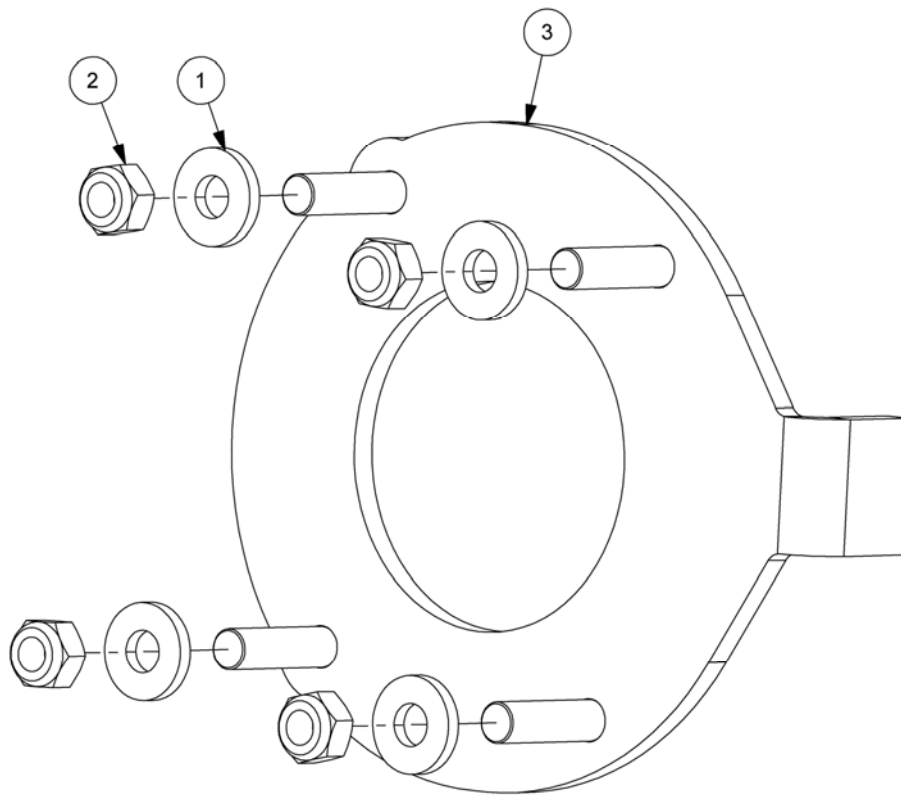

REF.	QTY.	PART No.	DESCRIPTION
		23013.10	MOTOR MOUNTING PLATE
1	4	7290051	CLAMP WASHER
2	4	9163006	NYLOC NUT
3	1	43458.08	MOTOR PLATE - RH

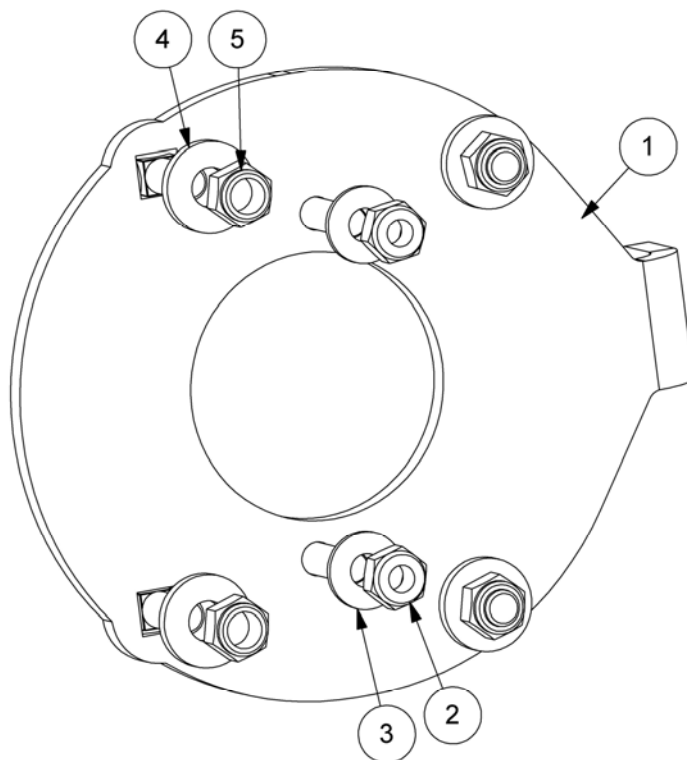

REF.	QTY.	PART No.	DESCRIPTION
		23013.11	MOTOR MOUNTING PLATE
1	1	7290476	MOTOR PLATE
2	2	9163005	NYLOC NUT
3	2	9100105	FLAT WASHER
4	4	7290051	CLAMP WASHER
5	4	0141004	UNF CLEVELOC NUT

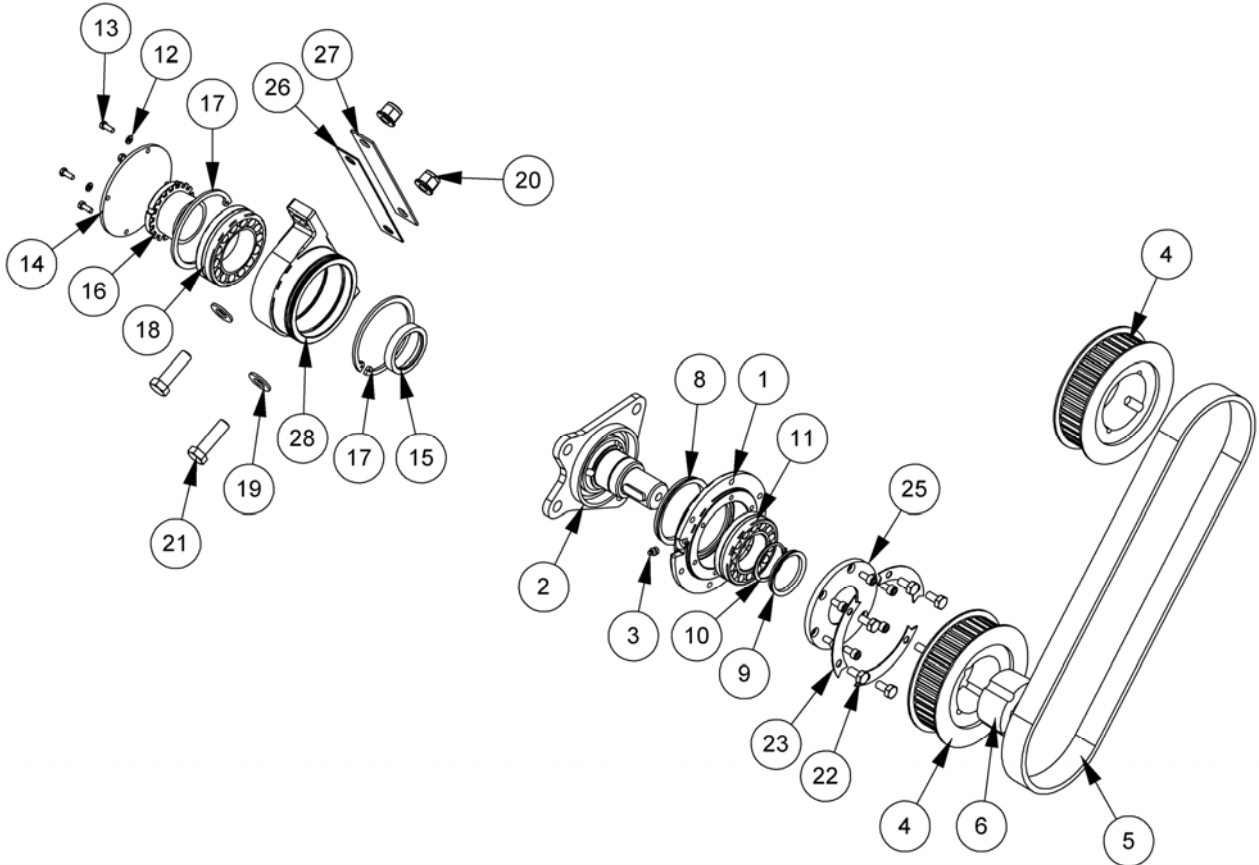

DRIVE MODULE

McCONNEL

Module(s): 22498.05

REF.	QTY.	PART No.	DESCRIPTION
		22498.05	DRIVE MODULE (BELT DRIVE)
1	1	7290321	BEARING HOUSING (DRIVE END)
2	1	22269.07	DRIVE HUB
3	2	0901121	GREASE NIPPLE
4	2	7290047	SPROCKET
5	1	7290046	BELT
6	1	7290016	TAPER LOCK BUSH
7	1	7290017	KEY
8	1	7290048	V SEAL
9	1	7290049	V SEAL
10	1	0401255	EXTERNAL CIRCLIP
11	1	0600095	SPHERICAL ROLLER BEARING
12	4	9100203	SPRING WASHER
13	4	9313033	SETSCREW
14	1	7290042	BEARING COVER
15	1	7290013	BEARING SPACER
16	1	0600097	ADAPTOR SLEEVE
17	2	7290056	INTERNAL CIRCLIP
18	1	0600096	SPHERICAL ROLLER BEARING
19	2	0100106	FLAT WASHER
20	2	9100024	SELF-LOCKING FLANGE NUT
21	2	9200023	BOLT
22	6	9313045	SETSCREW
23	3	7290073	SPECIAL TAB WASHER
24	6	9343034	CAPSCREW
25	1	7290023	BEARING RETAINER
26	1	7290424	SHIM - 2mm
27	1	7290425	SHIM - 3mm
28	1	7290322	BEARING HOUSING

1.6M ROLLER ASSEMBLY

McCONEL

Module(s): 21523.04

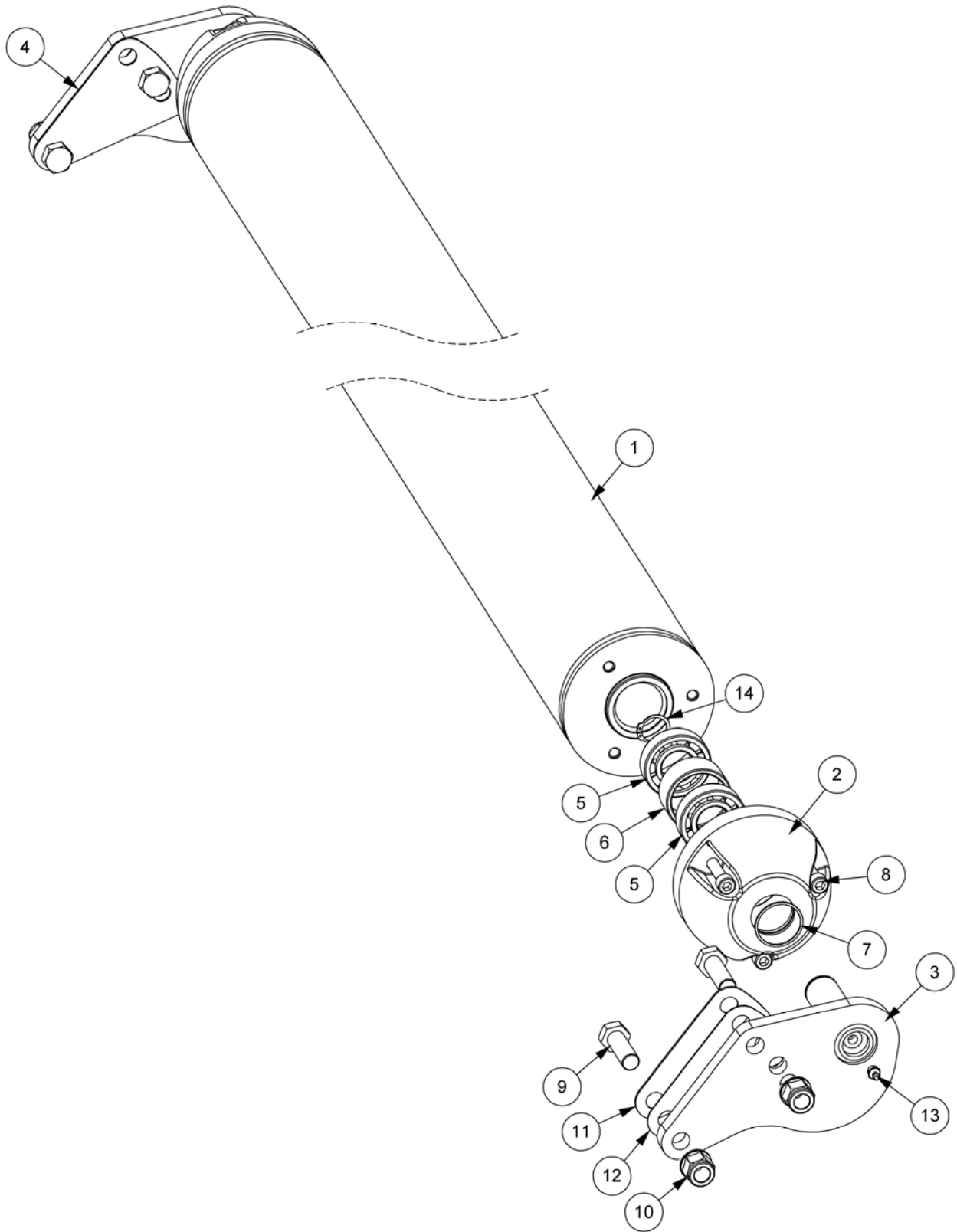

1.6M ROLLER ASSEMBLY**McCONNEL**

Module(s): 21523.04

REF.	QTY.	PART No.	DESCRIPTION
		21523.04	1.6M ROLLER ASSEMBLY
1	1	21394.26	1.6M ROLLER
2	2	21394.32	ROLLER END CAP
3	1	21524.09	ROLLER BRACKET - L/H
4	1	21524.10	ROLLER BRACKET - R/H
5	4	0600111	BALL BEARING
6	2	21523.31	BEARING SPACER
7	2	0402240	INTERNAL SPIROLOX RING
8	6	9343105	CAPSCREW
9	4	9200025	BOLT
10	4	9100024	SELF-LOCKING FLANGE NUT
11	<i>as req'd</i>	42257.02	ROLLER SHIM - 2.0mm
12	<i>as req'd</i>	42257.01	ROLLER SHIM - 1.2mm
13	2	0901121	GREASE NIPPLE
14	2	0401225	EXTERNAL CIRCLIP

1.6M ROLLER ASSEMBLY (Heavy Duty)

McCONEL

Module(s): 42241.27

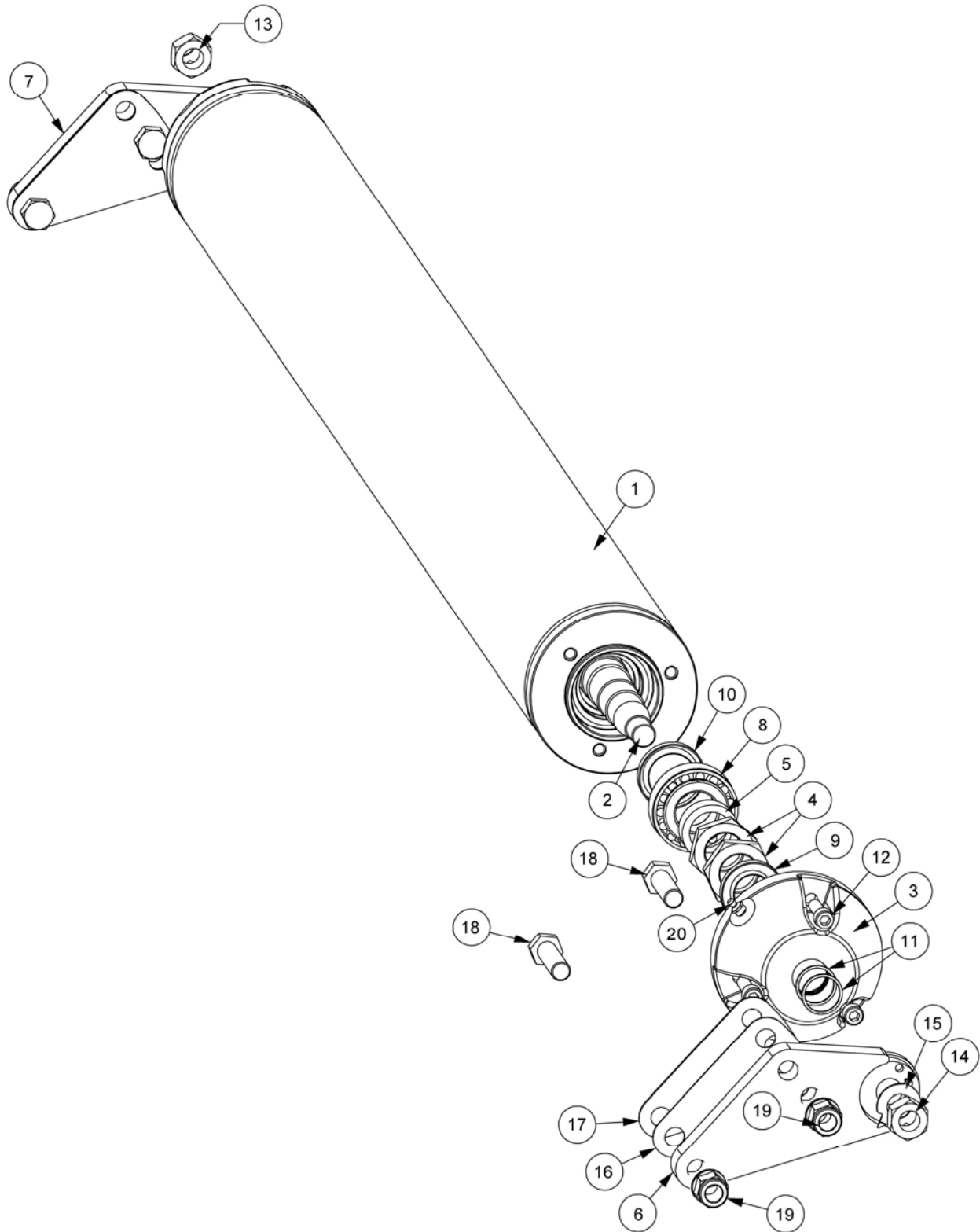

1.6M ROLLER ASSEMBLY (Heavy Duty)**McCONNEL**

Module(s): 42241.27

REF.	QTY.	PART No.	DESCRIPTION
		42241.27	1.6M ROLLER ASSEMBLY
1	1	42241.02	ROLLER
2	1	42242.02	ROLLER AXLE
3	2	42243.01	ROLLER END CAP
4	4	42244.01	SPECIAL LOCKNUT
5	2	42245.01	SPACER
6	1	42246.01	ROLLER BRACKET - L/H
7	1	42246.02	ROLLER BRACKET - R/H
8	2	0600105	TAPER BEARING
9	2	8629125	ROTARY SHAFT LIP SEAL
10	2	8629213	ROTARY SHAFT LIP SEAL
11	4	0412120	SPIROLOX RING
12	6	9343075	CAPSCREW
13	1	9113008	NUT
14	1	9100026	NUT (L/H)
15	2	7190023	TAB WASHER
16	2	42257.01	SHIM - 1.2MM
17	2	42257.02	SHIM - 2.0MM
18	4	9313097	BOLT
19	4	9143007	NUT
20	2	0901121	GREASE NIPPLE

1.6M RUBBER ROLLER ASSEMBLY

McCONEL

Module(s): 21523.44

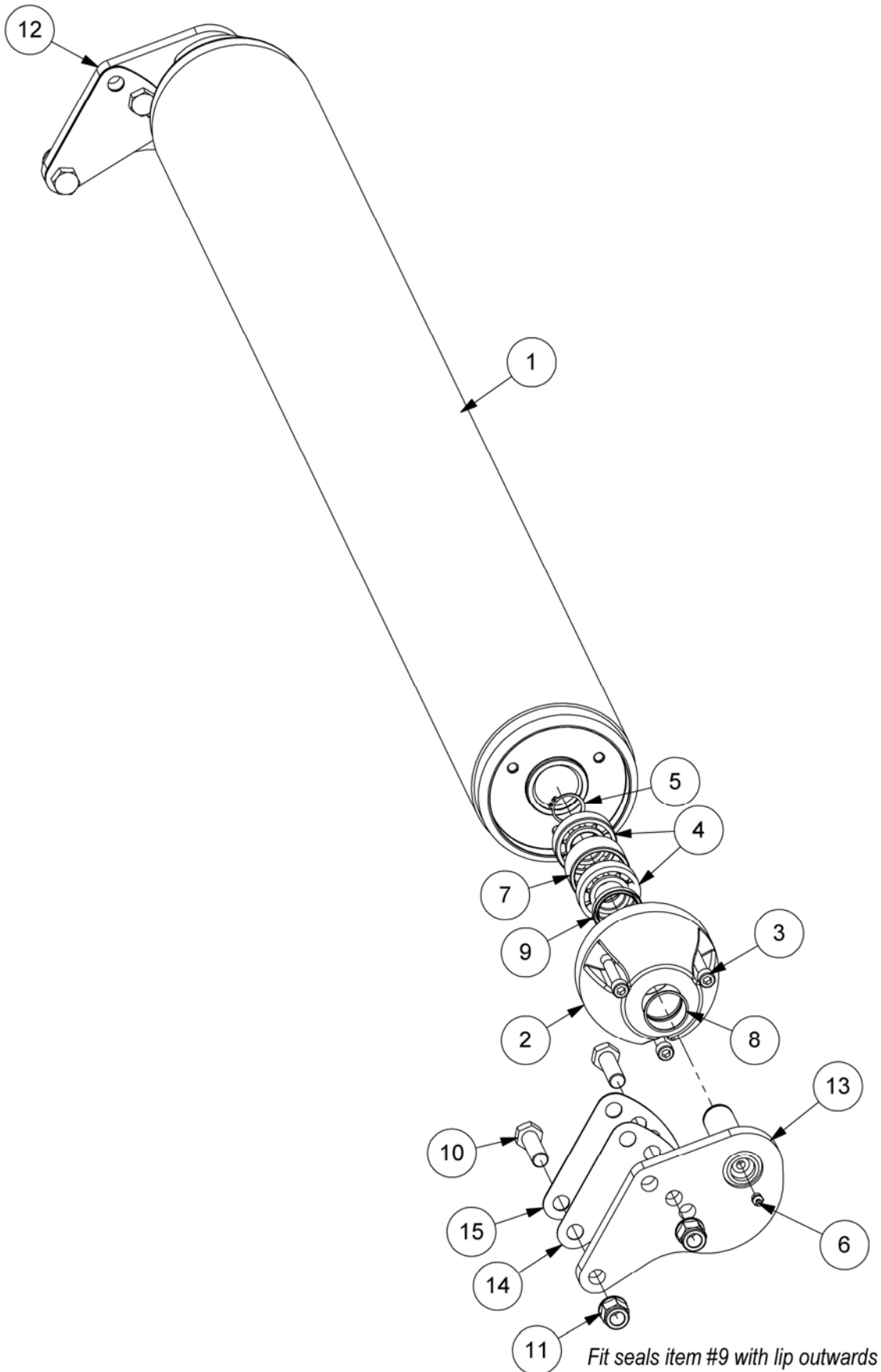

1.6M RUBBER ROLLER ASSEMBLY**McCONNEL**

Module(s): 21523.44

REF.	QTY.	PART No.	DESCRIPTION
		21523.44	1.2M R/ROLLER ASSEMBLY
1	1	21526.13	1.6M ROLLER WITH R/COVER
2	2	21394.32	ROLLER END CAP
3	6	9343105	CAPSCREW
4	4	0600111	BALL BEARING
5	2	0401230	EXTERNAL CIRCLIP
6	2	0901121	GREASE NIPPLE
7	2	21523.31	BEARING SPACER
8	2	0402240	INT. SPIROLOX RING
9	2	8629239	ROTARY SHAFT SEAL
10	4	9200025	BOLT
11	4	9100024	S/LOCKING FLANGE NUT
12	1	21524.10	ROLLER BRACKET RH
13	1	21524.09	ROLLER BRACKET LH
14	2	42257.01	ROLLER SHIM - 1.2mm
15	2	42257.02	ROLLER SHIM - 2.0mm

FRONT FLAP KIT – Optional Extra

McCONEL

Module(s): 7290411

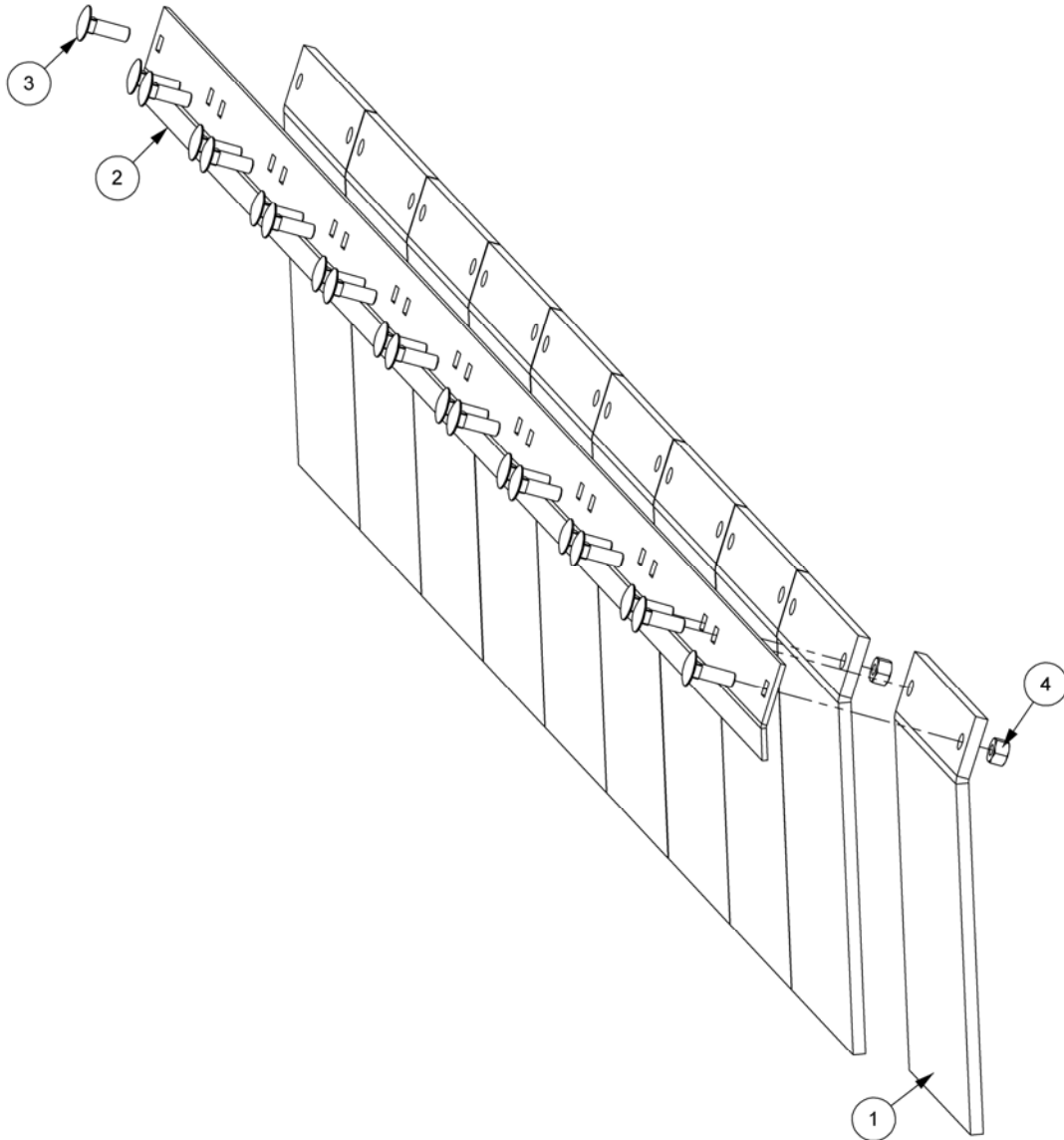

REF.	QTY.	PART No.	DESCRIPTION
		7290411	1.6M FRONT FLAP KIT
1	10	7290066	FRONT FLAP
2	1	7290404	CLAMP STRIP
3	20	9293054	CUP HEAD SQUARE SCREW
4	20	9143004	SELF-LOCKING NUT

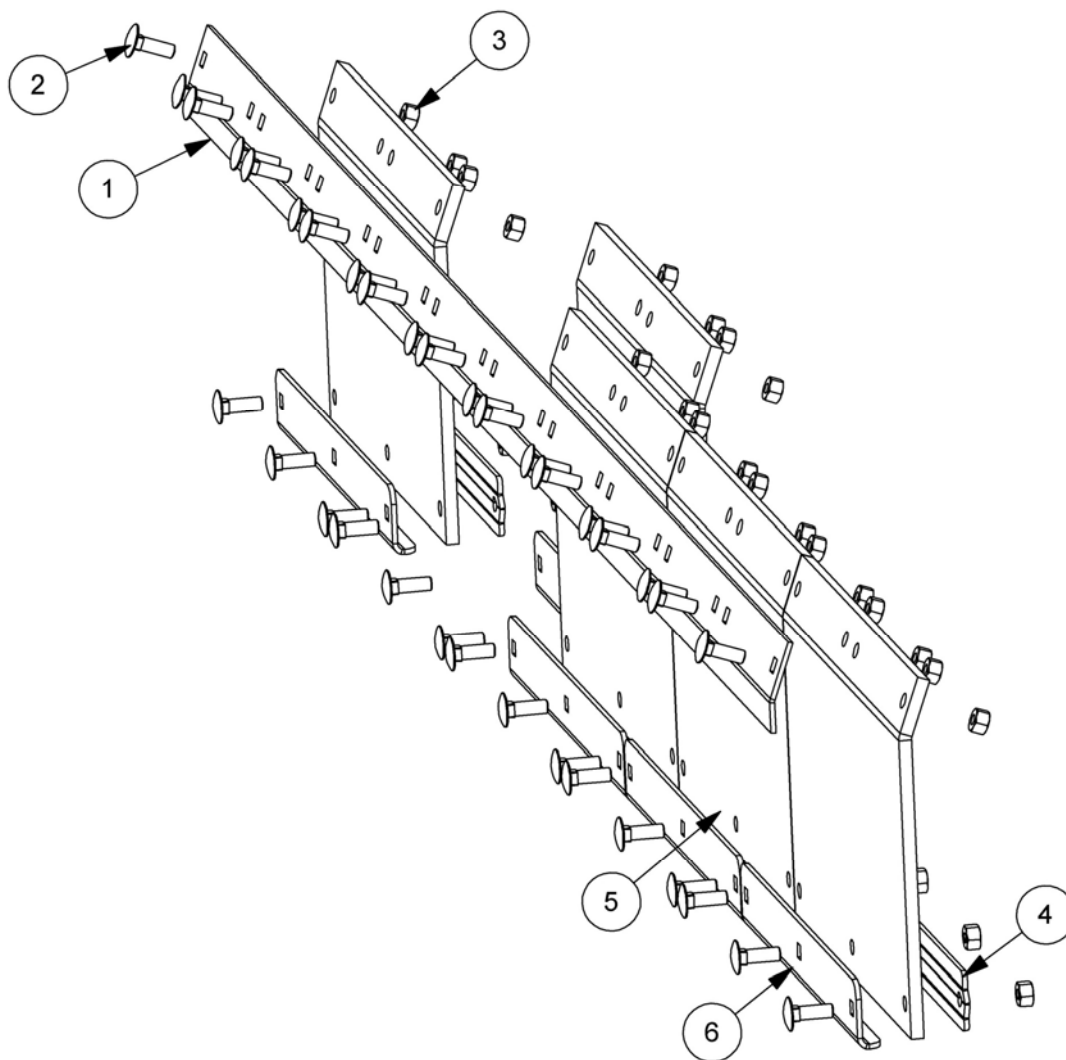

REF.	QTY.	PART No.	DESCRIPTION
		21541.04	1.6M FRONT FLAP KIT
1	1	7290404	CLAMP STRIP
2	35	9293054	CUP HEAD SCREW
3	35	9143004	NYLOC NUT
4	5	21541.16	EDGE PRESSING
5	5	21544.03	FRONT FLAP
6	5	21541.15	FLAP PRESSING

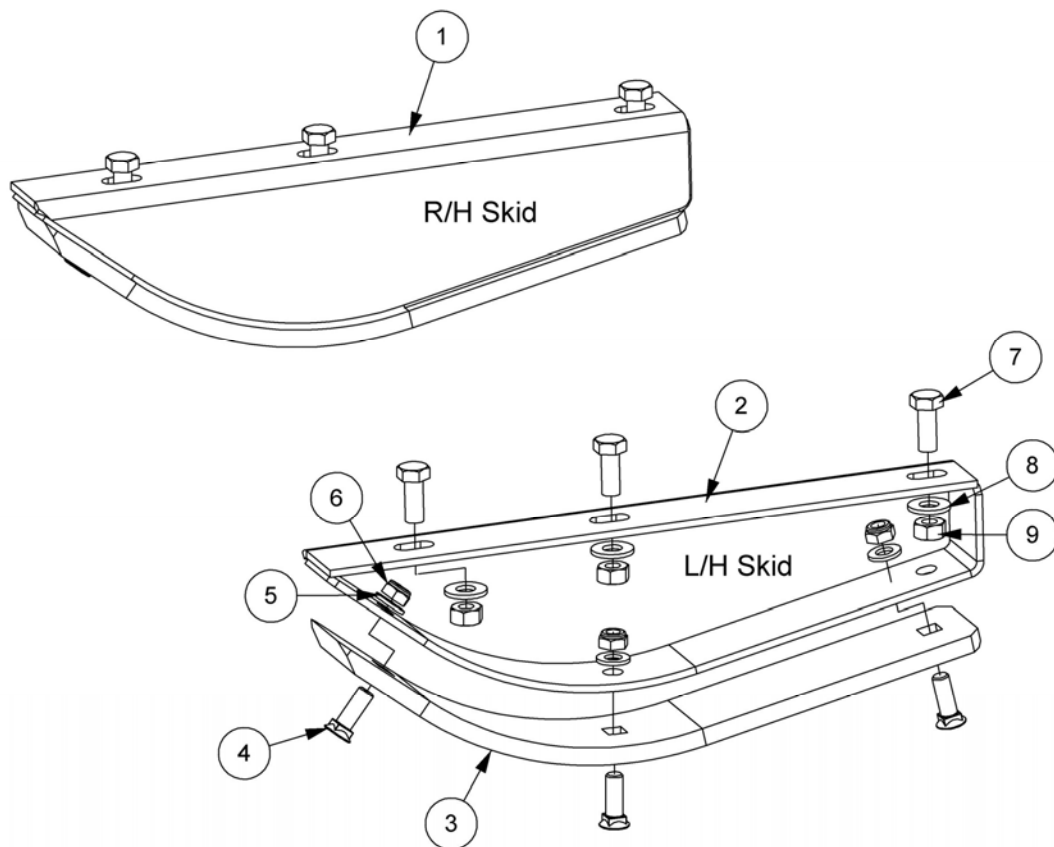

REF.	QTY.	PART No.	DESCRIPTION
		7290384	SKID KIT ASSEMBLY
1	1	7290389	SKID - R/H
2	1	7290390	SKID - L/H
3	2	7290391	REPLACEABLE SKID SHOE
4	6	6012034	PLOUGH BOLT
5	6	0100104	FLAT WASHER
6	6	0141004	SELF-LOCKING NUT
7	6	9313066	SETSCREW
8	6	9100106	FLAT WASHER
9	6	9143006	SELF-LOCKING NUT

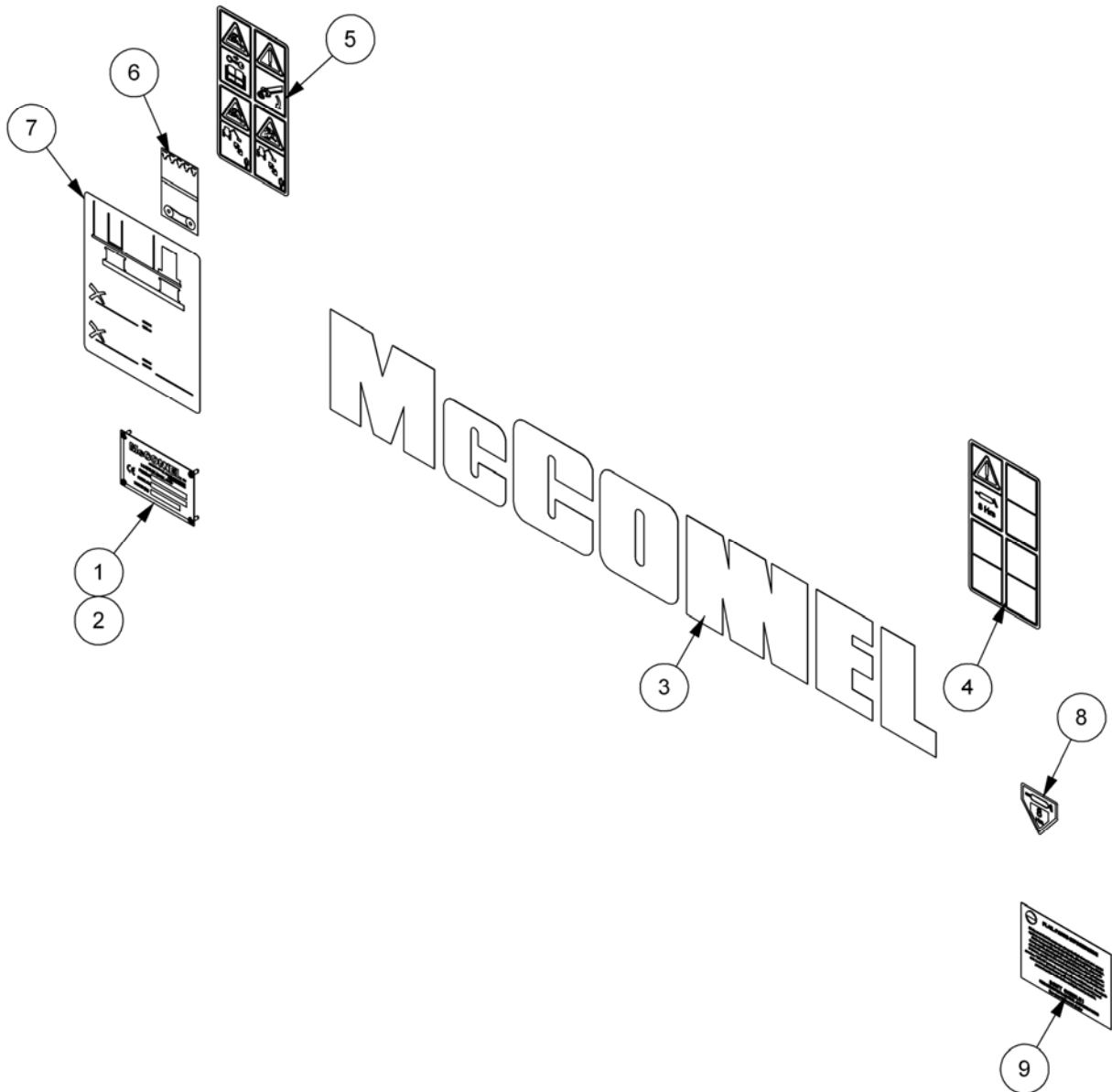

REF.	QTY.	PART No.	DESCRIPTION
		7390336	DECAL KIT (BELT DRIVE HEAD)
1	1	1335246	SERIAL No. PLATE
2	4	7103230	POP RIVET
3	1	1290527	DECAL - McCONNEL (BLACK)
4	1	1290738	DECAL - FLAILHEAD
5	1	09.821.35	DECAL - COMBINED EURO
6	1	1290065	DECAL - BELT TENSION
7	1	1290478	DECAL - BELT ALIGNMENT
8	1	09.810.01	DECAL - GREASE (8 HRS)
9	1	1290392	DECAL - PARTS INFORMATION

21978.22

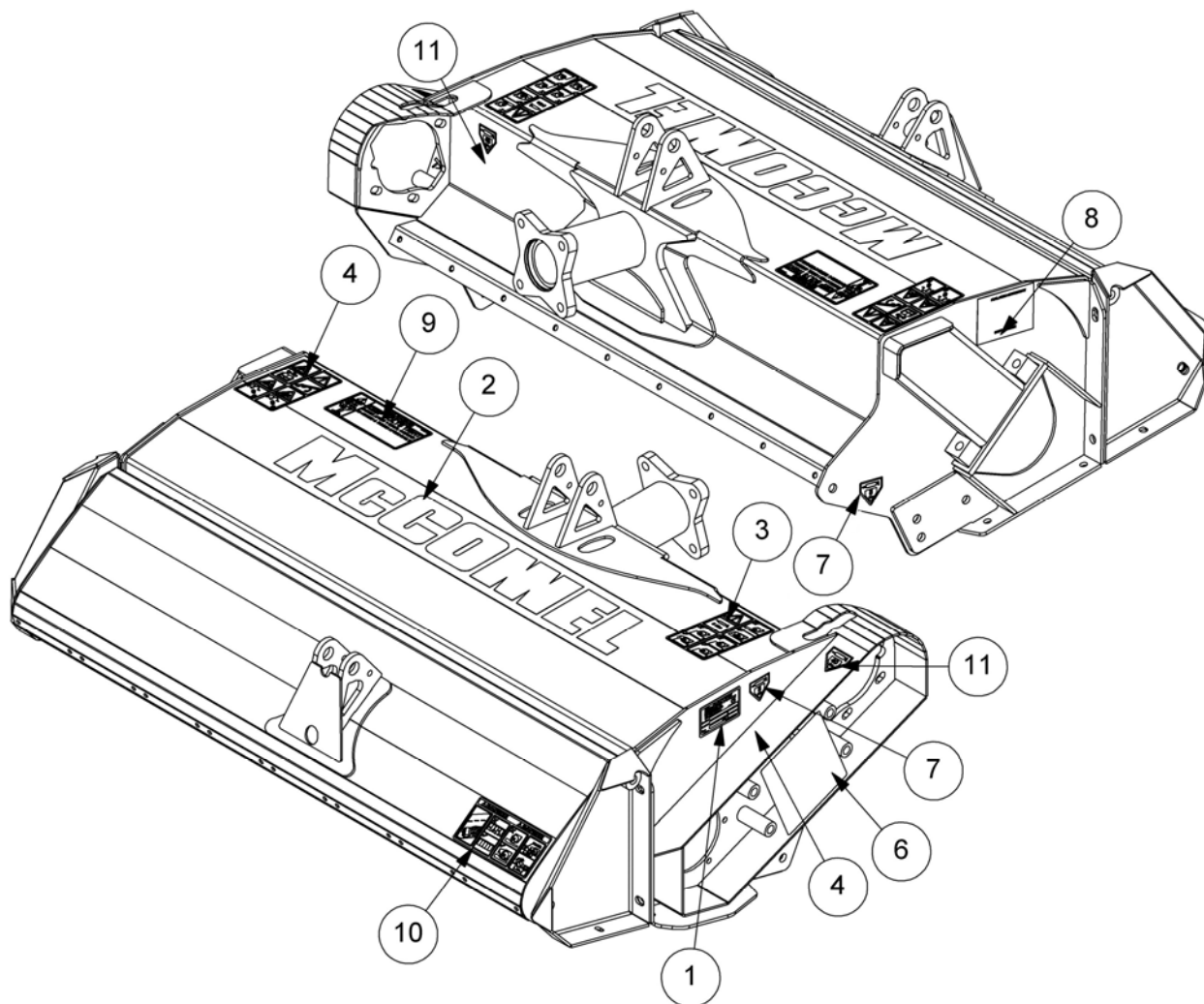

REF.	QTY.	PART No.	DESCRIPTION
		21978.22	DECAL KIT
1	1	41.094.18	SERIAL No. PLATE- McCONNEL
2	1	1290527	DECAL - McCONNEL
3	1	1290738	DECAL - FLAILHEAD
4	1	09.821.35	COMBINED EURO DECAL
5	1	1290065	DECAL - BELT TENSION
6	1	1290478	DECAL - BELT ALIGNMENT
7	2	09.810.01	DECAL - GREASE 8 HRS
8	1	1290392	STICKER - PARTS
9	1	1291045	DECAL KEEP BOLTS TIGHT
10	1	1291231	DECAL - GRASS MOWING
11	2	09.810.02	DECAL - GREASE 40 HRS



McConnel Limited, Temeside Works, Ludlow, Shropshire SY8 1JL. England.
Telephone: 01584 873131. Facsimile: 01584 876463. www.mcconnel.com