

Publication 484  
July 2005  
Part No. 41570.84  
Revision: 30.10.14

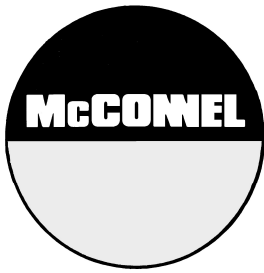

# 1.2M SUPERCUT FLAILHEAD

DIRECT DRIVE / CENTRE MOUNT

Operator & Parts Manual

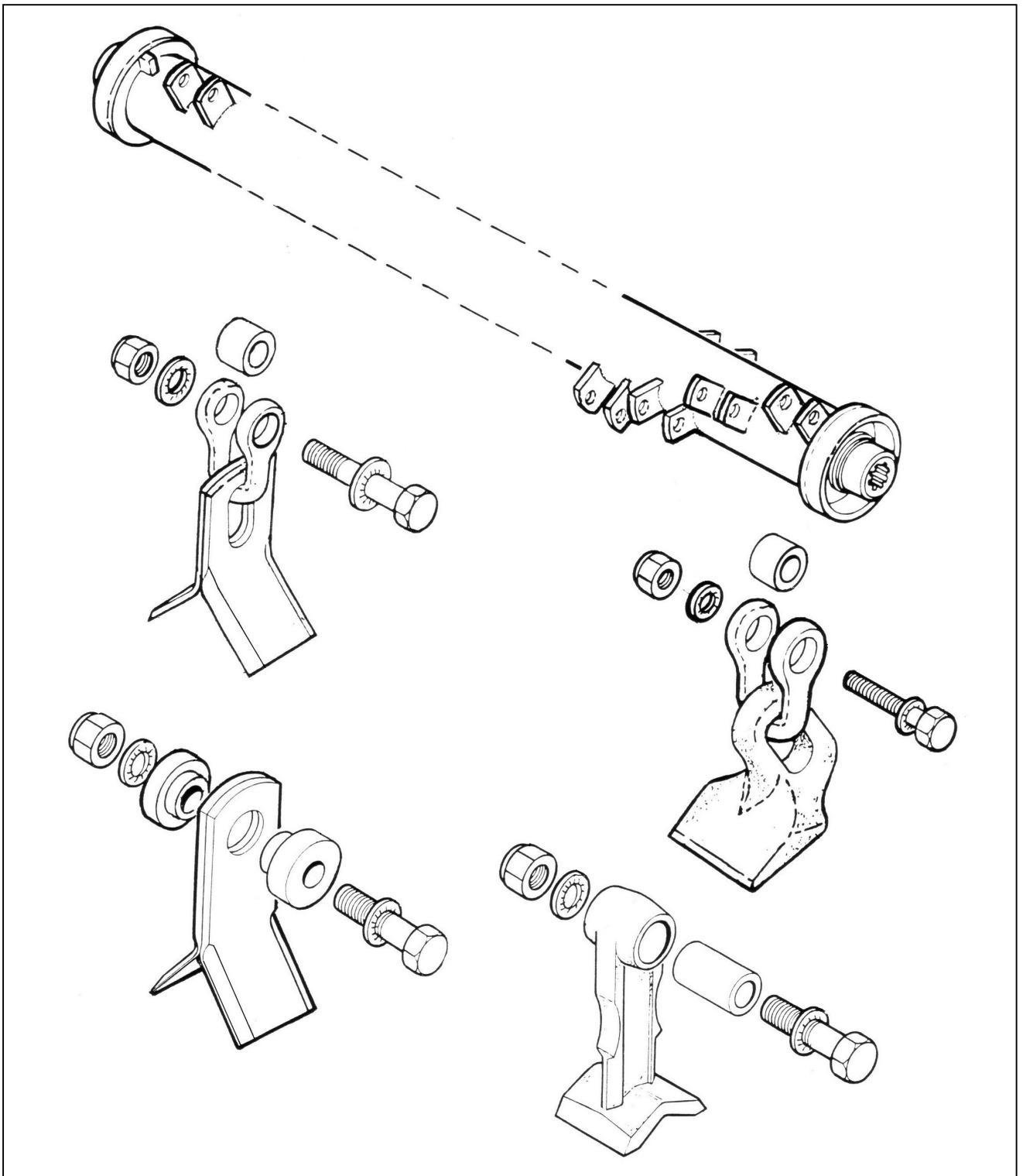

# IMPORTANT

## VERIFICATION OF WARRANTY REGISTRATION



### Dealer Warranty Information & Registration Verification

It is imperative that the selling dealer registers this machine with McConnel Limited before delivery to the end user – failure to do so may affect the validity of the machine warranty.

To register machines; log onto <https://my.mcconnel.com> and select 'Machine Registration' which can be found in the 'Warranty' section of the site. **Confirm to the customer that the machine has been registered by completing the verification form below.**

<b>Registration Verification</b>	Serial No. <input type="text"/>
Dealer Name: .....	
Dealer Address: .....	
Customer Name: .....	
Date of Warranty Registration: ...../...../.....	Dealer Signature: .....

### Note to Customer / Owner

Please ensure the section above has been completed and signed by the dealer to verify your machine has been registered with McConnel Limited.

**IMPORTANT:** During the initial 'bedding in' period of a new machine it is the customer's responsibility to regularly inspect all nuts, bolts and hose connections for tightness and re-tighten if required. New hydraulic connections occasionally weep small amounts of oil as the seals and joints settle in – where this occurs it can be cured by re-tightening the connection – *refer to torque settings chart below*. The tasks stated above should be performed on an hourly basis during the first day of work and at least daily thereafter as part of the machine's general maintenance procedure.

CAUTION: DO NOT OVER TORQUE HYDRAULIC FITTINGS AND HOSES

### Torque Settings for Hydraulic Fittings

Hydraulic Hose Ends		
BSP	Setting	Metric
1/4"	18 Nm	19 mm
3/8"	31 Nm	22 mm
1/2"	49 Nm	27 mm
5/8"	60 Nm	30 mm
3/4"	80 Nm	32 mm
1"	125 Nm	41 mm
1.1/4"	190 Nm	50 mm
1.1/2"	250 Nm	55 mm
2"	420 Nm	70 mm

Port Adaptors with Bonded Seals		
BSP	Setting	Metric
1/4"	34 Nm	19 mm
3/8"	47 Nm	22 mm
1/2"	102 Nm	27 mm
5/8"	122 Nm	30 mm
3/4"	149 Nm	32 mm
1"	203 Nm	41 mm
1.1/4"	305 Nm	50 mm
1.1/2"	305 Nm	55 mm
2"	400 Nm	70 mm



# WARRANTY POLICY

## WARRANTY REGISTRATION

All machines must be registered, by the selling dealer with McConnel Ltd, before delivery to the end user. On receipt of the goods it is the buyer's responsibility to check that the Verification of Warranty Registration in the Operator's Manual has been completed by the selling dealer.

### 1. LIMITED WARRANTIES

- 1.01. *All mounted machines supplied by McConnel Ltd are warranted to be free from defects in material and workmanship from the date of sale to the original purchaser for a period of 12 months, unless a different period is specified.  
All Self Propelled Machines supplied by McConnel Ltd are warranted to be free from defects in material and workmanship from the date of sale to the original purchaser for a period of 12 months or 1500 hours. Engine warranty will be specific to the Manufacturer of that unit.*
- 1.02. *All spare parts supplied by McConnel Ltd and purchased by the end user are warranted to be free from defects in material and workmanship from the date of sale to the original purchaser for a period of 6 months. All parts warranty claims must be supported by a copy of the failed part invoice to the end user. We cannot consider claims for which sales invoices are not available.*
- 1.03. *The warranty offered by McConnel Ltd is limited to the making good by repair or replacement for the purchaser any part or parts found, upon examination at its factory, to be defective under normal use and service due to defects in material or workmanship. Returned parts must be complete and unexamined. Pack the component(s) carefully so that any transit damage is avoided. All ports on hydraulic items should be drained of oil and securely plugged to prevent seepage and foreign body ingress. Certain other components, electrical items for example, may require particular care when packing to avoid damage in transit.*
- 1.04. *This warranty does not extend to any product from which McConnel Ltd's serial number plate has been removed or altered.*
- 1.05. *The warranty policy is valid for machines registered in line with the terms and conditions detailed and on the basis that the machines do not extend a period of 24 months or greater since their original purchase date, that is the original invoice date from McConnel Limited.  
Machines that are held in stock for more than 24 months cannot be registered for warranty.*
- 1.06. *This warranty does not apply to any part of the goods, which has been subjected to improper or abnormal use, negligence, alteration, modification, fitment of non-genuine parts, accident damage, or damage resulting from contact with overhead power lines, damage caused by foreign objects (e.g. stones, iron, material other than vegetation), failure due to lack of maintenance, use of incorrect oil or lubricants, contamination of the oil, or which has served its normal life. This warranty does not apply to any expendable items such as blades, belts, clutch linings, filter elements, flails, flap kits, skids, soil engaging parts, shields, guards, wear pads, pneumatic tyres or tracks.*
- 1.07. *Temporary repairs and consequential loss - i.e. oil, downtime and associated parts are specifically excluded from the warranty.*
- 1.08. *Warranty on hoses is limited to 12 months and does not include hoses which have suffered external damage. Only complete hoses may be returned under warranty, any which have been cut or repaired will be rejected.*
- 1.09. *Machines must be repaired immediately a problem arises. Continued use of the machine after a problem has occurred can result in further component failures, for which McConnel Ltd cannot be held liable, and may have safety implications.*
- 1.10. *If in exceptional circumstances a non McConnel Ltd part is used to effect a repair, warranty reimbursement will be at no more than McConnel Ltd's standard dealer cost for the genuine part.*

- 1.11. *Except as provided herein, no employee, agent, dealer or other person is authorised to give any warranties of any nature on behalf of McConnell Ltd.*
- 1.12. *For machine warranty periods in excess of 12 months the following additional exclusions shall apply:*
  - 1.12.1. *Hoses, exposed pipes and hydraulic tank breathers.*
  - 1.12.2. *Filters.*
  - 1.12.3. *Rubber mountings.*
  - 1.12.4. *External electric wiring.*
  - 1.12.5. *Bearings and seals*
  - 1.12.6. *External Cables, Linkages*
  - 1.12.7. *Loose/Corroded Connections, Light Units, LED's*
  - 1.12.8. *Comfort items such as Operator Seat, Ventilation, Audio Equipment*
- 1.13. *All service work, particularly filter changes, must be carried out in accordance with the manufacturer's service schedule. Failure to comply will invalidate the warranty. In the event of a claim, proof of the service work being carried out may be required.*
- 1.14. *Repeat or additional repairs resulting from incorrect diagnosis or poor quality previous repair work are excluded from warranty.*

***NB Warranty cover will be invalid if any non-genuine parts have been fitted or used. Use of non-genuine parts may seriously affect the machine's performance and safety. McConnell Ltd cannot be held responsible for any failures or safety implications that arise due to the use of non-genuine parts.***

## **2. REMEDIES AND PROCEDURES**

- 2.01. *The warranty is not effective unless the Selling Dealer registers the machine, via the McConnell web site and confirms the registration to the purchaser by completing the confirmation form in the operator's manual.*
- 2.02. *Any fault must be reported to an authorised McConnell Ltd dealer as soon as it occurs. Continued use of a machine, after a fault has occurred, can result in further component failure for which McConnell Ltd cannot be held liable.*
- 2.03. *Repairs should be undertaken within two days of the failure. Claims submitted for repairs undertaken more than 2 weeks after a failure has occurred, or 2 days after the parts were supplied will be rejected, unless the delay has been authorised by McConnell Ltd. Please note that failure by the customer to release the machine for repair will not be accepted as a reason for delay in repair or submitting warranty claims.*
- 2.04. *All claims must be submitted, by an authorised McConnell Ltd Service Dealer, within 30 days of the date of repair.*
- 2.05. *Following examination of the claim and parts, McConnell Ltd will pay, at their discretion, for any valid claim the invoiced cost of any parts supplied by McConnell Ltd and appropriate labour and mileage allowances if applicable.*
- 2.06. *The submission of a claim is not a guarantee of payment.*
- 2.07. *Any decision reached by McConnell Ltd. is final.*

## **3. LIMITATION OF LIABILITY**

- 3.01. *McConnell Ltd disclaims any express (except as set forth herein) and implied warranties with respect to the goods including, but not limited to, merchantability and fitness for a particular purpose.*
- 3.02. *McConnell Ltd makes no warranty as to the design, capability, capacity or suitability for use of the goods.*
- 3.03. *Except as provided herein, McConnell Ltd shall have no liability or responsibility to the purchaser or any other person or entity with respect to any liability, loss, or damage caused or alleged to be caused directly or indirectly by the goods including, but not limited to, any indirect, special, consequential, or incidental damages resulting from the use or operation of the goods or any breach of this warranty. Notwithstanding the above limitations and warranties, the manufacturer's liability hereunder for damages incurred by the purchaser or others shall not exceed the price of the goods.*
- 3.04. *No action arising out of any claimed breach of this warranty or transactions under this warranty may be brought more than one (1) year after the cause of the action has occurred.*

#### **4. MISCELLANEOUS**

- 4.01. McConnel Ltd may waive compliance with any of the terms of this limited warranty, but no waiver of any terms shall be deemed to be a waiver of any other term.*
- 4.02. If any provision of this limited warranty shall violate any applicable law and is held to be unenforceable, then the invalidity of such provision shall not invalidate any other provisions herein.*
- 4.03. Applicable law may provide rights and benefits to the purchaser in addition to those provided herein.*

---

*McConnel Limited*



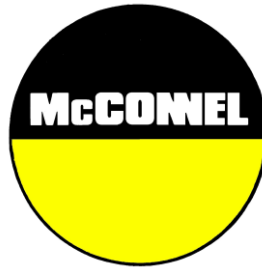

*For Safety and Performance...*

**ALWAYS READ THE BOOK FIRST**

**McCONEL LIMITED**

**Temeside Works  
Ludlow  
Shropshire  
England**

**Telephone: +44 (0)1584 873131  
www.mcconel.com**

---

**- NOISE STATEMENT -**

The equivalent daily personal noise exposure from this machine measured at the operators' ear is within the range 78 – 85 dB, these figures apply to a normal distribution of use where the noise fluctuates between zero and maximum. The figures assume that the machine is fitted to a tractor with a 'quiet' cab with the windows closed in a generally open environment. We recommend that the windows are kept closed. With the cab rear window open the equivalent daily personal noise exposure will increase to a figure within the range 82 – 88 dB. At an equivalent daily noise exposure level of 85 – 90 dB ear protection is recommended and must always be used if any window is left open.



Operating, servicing and maintaining this equipment can expose you to chemicals including gasoline, diesel fuel, lubricants, petroleum products, engine exhaust, carbon monoxide, and phthalates, which are known to the State of California to cause cancer and birth defects or other reproductive harm. To minimize exposure, avoid breathing exhaust, do not idle the engine except as necessary, service your vehicle in a well-ventilated area and wear gloves or wash your hands frequently when servicing your vehicle. Battery posts, terminals and related accessories contain lead and lead compounds, chemicals known to the state of California to cause cancer, birth defects or other reproductive harm. For more information go to [www.P65Warnings.ca.gov](http://www.P65Warnings.ca.gov). This website, operated by California's Office of Environmental Health Hazard Assessment, provides information about these chemicals and how individuals may be exposed to them.





# CONTENTS

---

**Page No.**

**Operator Section**

General Information	3
Safety Information	5
Cutting Limitations	9
Roller Positions	9
Flailhead Arrangement for Mowing	10
Flailhead Arrangement for Hedge Cutting	11
Tractor Forward Speed	12
Hedgecutting Procedure	13
Wire Trap	14
Maintenance	15

**Parts Section**

Flailhead Assembly	20
Rotor & Flail Options	24
Roller Assembly	26
Front Flap Kit ( <i>Optional Extra</i> )	27
Skid Kit ( <i>Optional Extra</i> )	28
Decal Kit	29



## GENERAL INFORMATION

---

Always read this manual before fitting or operating the machine – whenever any doubt exists contact your dealer or the McConnel Service Department for advice and assistance.

Use only McConnel Genuine Service Parts on McConnel Equipment and Machines

DEFINITIONS – *The following definitions apply throughout this manual:*

### WARNING

*An operating procedure, technique etc., which –  
can result in personal injury or loss of life if not observed carefully.*

### CAUTION

*An operating procedure, technique etc., which –  
can result in damage to either machine or equipment if not observed carefully.*

### NOTE

*An operating procedure, technique etc., which –  
is considered essential to emphasis.*

### LEFT AND RIGHT HAND

*This term is applicable to the machine when attached to the tractor and is viewed  
from the rear – this also applies to tractor references.*

## MACHINE & DEALER INFORMATION

*Record the Serial Number of your machine on this page and always quote this number when ordering parts. Whenever information concerning the machine is requested remember also to state the make and model of tractor to which the machine is fitted.*

**Machine Serial Number:**

**Installation Date:**

**Machine Model details:**

**Dealer Name:**

**Dealer Address:**

**Dealer Telephone No:**

**Dealer Email Address:**





This machine has the potential to be extremely dangerous, in the wrong hands it can kill or maim. It is therefore imperative that both owner, and operator of this machine, read and understand the following section to ensure that they are fully aware of the dangers that do, or may exist, and their responsibilities surrounding the use and operation of the machine. The operator of this machine is responsible not only for their own safety but equally for the safety of others who may come into the close proximity of the machine, as the owner you are responsible for both.

When the machine is not in use the cutting head should be lowered to rest on the ground. In the event of a fault being detected with the machine's operation it should be stopped immediately and not used again until the fault has been corrected by a qualified technician.

#### POTENTIAL SIGNIFICANT DANGERS ASSOCIATED WITH THE USE OF THIS MACHINE:

- ▲ *Being hit by debris thrown by rotating components.*
- ▲ *Being hit by machine parts ejected through damage during use.*
- ▲ *Being caught on a rotating power take-off (PTO) shaft.*
- ▲ *Being caught in other moving parts i.e.: belts, pulleys and cutting heads.*
- ▲ *Electrocution from Overhead Power Lines (by contact with or 'flashover' from).*
- ▲ *Being hit by cutting heads or machine arms as they move.*
- ▲ *Becoming trapped between tractor and machine when hitching or unhitching.*
- ▲ *Tractor overbalancing when machine arm is extended.*
- ▲ *Injection of high-pressure oil from hydraulic hoses or couplings.*
- ▲ *Machine overbalancing when freestanding (out of use).*
- ▲ *Road traffic accidents due to collision or debris on the road.*

## BEFORE USING THIS MACHINE YOU MUST:

- ▲ *Ensure you read all sections of the operator handbook.*
- ▲ *Ensure the operator is, or has been, properly trained to use the machine.*
- ▲ *Ensure the operator has been issued with and reads the operator handbook.*
- ▲ *Ensure the operator understands and follows the instructions in operator handbook.*
- ▲ *Ensure the tractor front, rear and side(s) are fitted with metal mesh or polycarbonate guards of suitable size and strength to protect the operator against thrown debris or parts.*
- ▲ *Ensure tractor guards are fitted correctly, are undamaged and kept properly maintained.*
- ▲ *Ensure that all machine guards are in position, are undamaged, and are kept maintained in accordance with the manufacturer's recommendations.*
- ▲ *Ensure flails and their fixings are of a type recommended by the manufacturer, are securely attached and that none are missing or damaged.*
- ▲ *Ensure hydraulic pipes are carefully and correctly routed to avoid damage by chaffing, stretching or pinching and that they are held in place with the correct fittings.*
- ▲ *Always follow the manufacturer's instructions for attachment and removal of the machine from the tractor.*
- ▲ *Check that the machine fittings and couplings are in good condition.*
- ▲ *Ensure the tractor meets the minimum weight recommendations of the machine's manufacturer and that ballast is used as necessary.*
- ▲ *Always inspect the work area thoroughly before starting to note obstacles and remove wire, bottles, cans and other debris.*
- ▲ *Use clear suitably sized warning signs to alert others to the nature of the machine working within that area. Signs should be placed at both ends of the work site. (It is recommended that signs used are of a size and type specified by the Department of Transport and positioned in accordance with their, and the Local Highways Authority, guidelines).*
- ▲ *Ensure the operator is protected from noise. Ear defenders should be worn and tractor cab doors and windows must be kept closed. Machine controls should be routed through proprietary openings in the cab to enable all windows to be shut fully.*
- ▲ *Always work at a safe speed taking account of the conditions i.e.: terrain, highway proximity and obstacles around and above the machine. Extra special attention should be applied to Overhead Power Lines. Some of our machines are capable of reach in excess of 8 metres (26 feet) this means they have the potential to well exceed, by possibly 3 metres (9' 9"), the lowest legal minimum height of 5.2 metres from the ground for 11,000 and 33,000 volt power lines. It cannot be stressed enough the dangers that surround this capability, it is therefore vital that the operator is fully aware of the maximum height and reach of the machine, and that they are fully conversant with all aspects regarding the safe minimum distances that apply when working with machines in close proximity to Power Lines. (Further information on this subject can be obtained from the Health & Safety Executive or your Local Power Company).*

- ▲ *Always disengage the machine, kill the tractor engine, remove and pocket the key before dismounting for any reason.*
- ▲ *Always clear up all debris left at the work area, it may cause hazard to others.*
- ▲ *Always ensure when you remove your machine from the tractor that it is left in a safe and stable position using the stands and props provided and secured if necessary.*

#### WHEN NOT TO USE THIS MACHINE:

- ▲ *Never attempt to use this machine if you have not been trained to do so.*
- ▲ *Never use a machine until you have read and understood the operator handbook, are familiar with it, and practiced the controls.*
- ▲ *Never use a machine that is poorly maintained.*
- ▲ *Never use a machine if guards are missing or damaged.*
- ▲ *Never use a machine on which the hydraulic system shows signs of wear or damage.*
- ▲ *Never fit, or use, a machine on a tractor that does not meet the manufacturer's minimum specification level.*
- ▲ *Never use a machine fitted to a tractor that does not have suitable front, rear and side(s) cab guarding made of metal mesh or polycarbonate.*
- ▲ *Never use the machine if the tractor cab guarding is damaged, deteriorating or badly fitted.*
- ▲ *Never turn a machine cutting head to an angle that causes debris to be ejected towards the cab.*
- ▲ *Never start or continue to work a machine if people are nearby or approaching - Stop and wait until they are at a safe distance before continuing. WARNING: Some Cutting Heads may continue to 'freewheel' for up to 40 seconds after being stopped.*
- ▲ *Never attempt to use a machine on materials in excess of its capability.*
- ▲ *Never use a machine to perform a task it has not been designed to do.*
- ▲ *Never operate the tractor or machine controls from any position other than from the driving seat, especially whilst hitching or unhitching the machine.*
- ▲ *Never carry out maintenance of a machine or a tractor whilst the engine is running – the engine should be switched off, the key removed and pocketed.*
- ▲ *Never leave a machine unattended in a raised position – it should be lowered to the ground in a safe position on a level firm site.*
- ▲ *Never leave a tractor with the key in or the engine running.*
- ▲ *Never carry out maintenance on any part or component of a machine that is raised unless that part or component has been properly substantially braced or supported.*
- ▲ *Never attempt to detect a hydraulic leak with your hand – use a piece of cardboard.*
- ▲ *Never allow children near to, or play on, a tractor or machine under any circumstances.*



## ADDITIONAL SAFETY ADVICE

### Training

Operators need to be competent and fully capable of operating this machine in a safe and efficient way prior to attempting to use it in any public place. We advise therefore that the prospective operator make use of relevant training courses available such as those run by the Agricultural Training Board, Agricultural Colleges, Dealers and McConnel.

### Working in Public Places

When working in public places such as roadsides, consideration should be paid to others in the vicinity. Stop the machine immediately when pedestrians, cyclists and horse riders etc. pass. Restart only when they are at a distance that causes no risk to their safety.

### Warning Signs

It is advisable that any working area be covered by suitable warning signs and statutory in public places. Signs should be highly visible and well placed in order to give clear advanced warning of the hazard. Contact the Department of Transport or your Local Highways Authority to obtain detailed information on this subject. The latter should be contacted prior to working on the public highway advising them of the time and location of the intended work asking what is required by way of signs and procedure. – ‘*Non-authorized placement of road signs may create offences under the Highways Act*’.

### Suggested Warning Signs Required

**“Road works ahead”** warning sign with a supplementary **“Hedge cutting”** plate. **“For 1 mile”** or appropriate shorter distance may be added to the plate.

**“Road narrows”** warning sign with supplementary **“Single file traffic”** plate.

White on blue **“Keep right”** (\*) arrow sign on rear of machine.

\* Note – this applies to UK Market machines where traffic passes to the right of a machine working in the same direction as the traffic flow. The direction, use and colour of the arrow sign will depend on the country of use and the Local Highway Authorities regulations in the locality.

### Use of Warning Signs

- ▲ On two-way roads one set of signs is needed facing traffic in each direction.
- ▲ Work should be within 1 mile of the signs.
- ▲ Work only when visibility is good and at times of low risk e.g.: NOT during ‘rush-hour’.
- ▲ Vehicles should have an amber-flashing beacon.
- ▲ Ideally, vehicles should be conspicuously coloured.
- ▲ Debris should be removed from the road and path as soon as practicable, and at regular intervals, wearing high visibility clothing and before removing the hazard warning signs.
- ▲ Collect all road signs promptly when the job is completed.

---

Although the information given here covers a wide range of safety subjects, it is impossible to predict every eventuality that can occur under differing circumstances whilst operating this machine. No advice given here can replace ‘good common sense’ and ‘total awareness’ at all times, but will go a long way towards the safe use of your McConnel machine.

---

# OPERATION

## Material Thickness Cutting Limitations



## Roller Positions

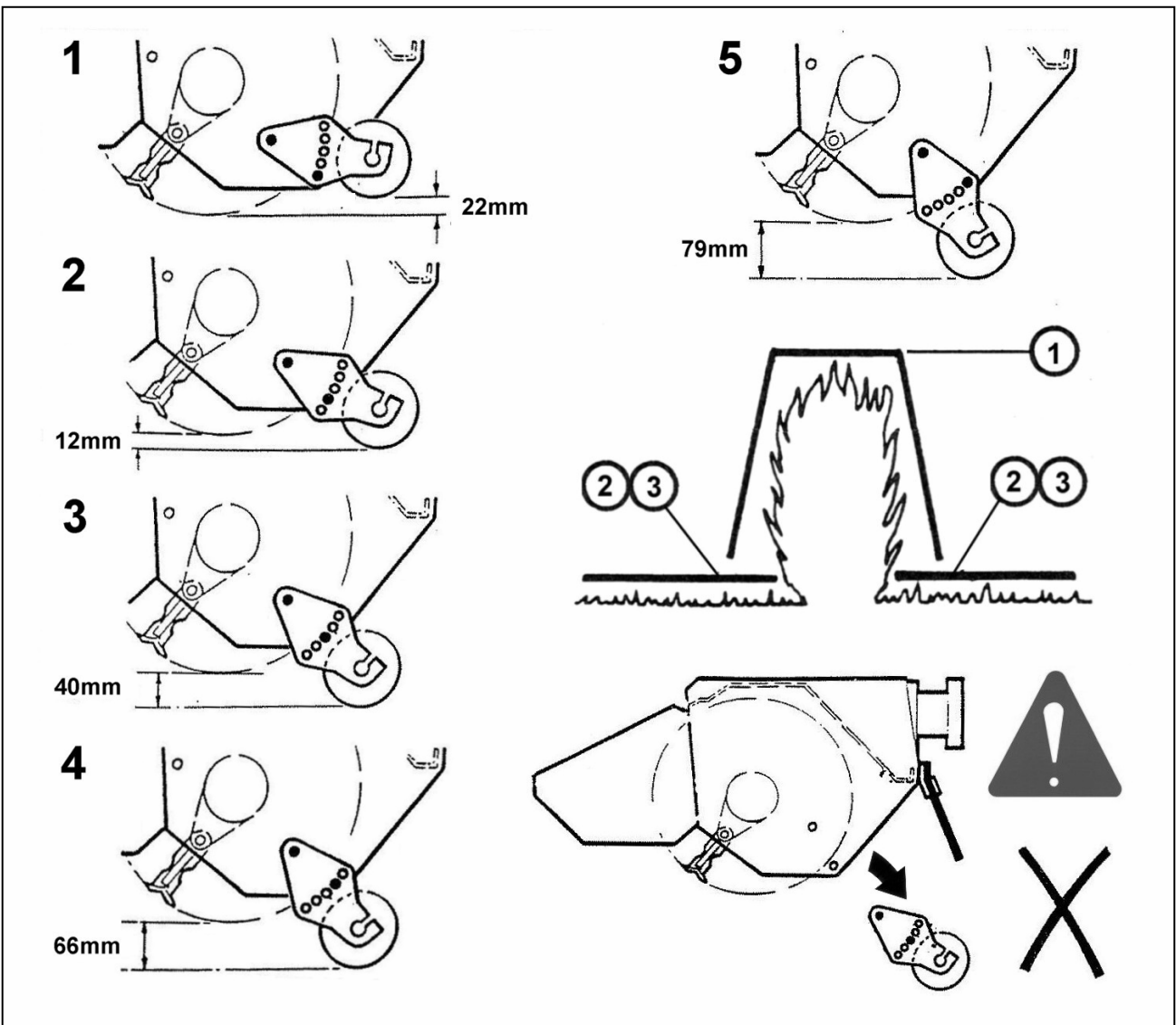

## Preliminary Precautions

Inspect the work area prior to operation, remove all hazardous materials and note the locations of immovable obstructions.

# FLAILHEAD ARRANGEMENT

## MOWING

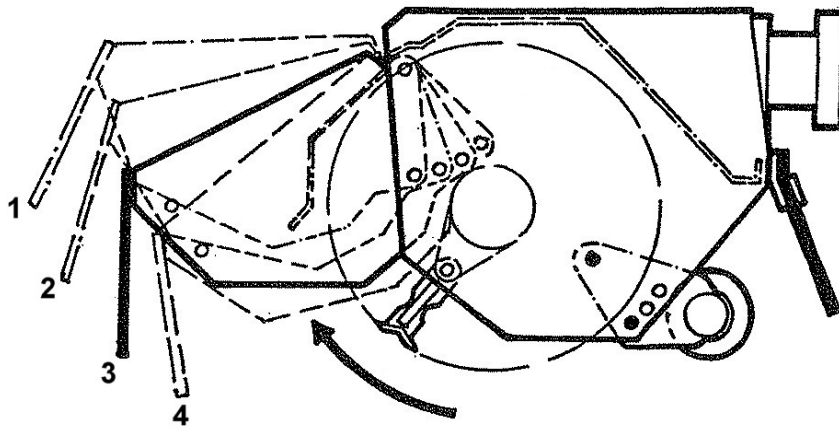

For mowing work the rotor must always cut with an upwards rotation and the roller set to a working height that is below the level of the skids (or rotor if skids are not fitted) – i.e. in position 2, 3, 4 or 5 as shown on the previous page.

The front hood has four height adjustment positions – the lowest possible position which allows the material to be cut to enter the head should always be used.

**WARNING:** Raising the front hood increases the possibility of debris escaping – never operate the machine with the front hood set any higher than is absolutely necessary.

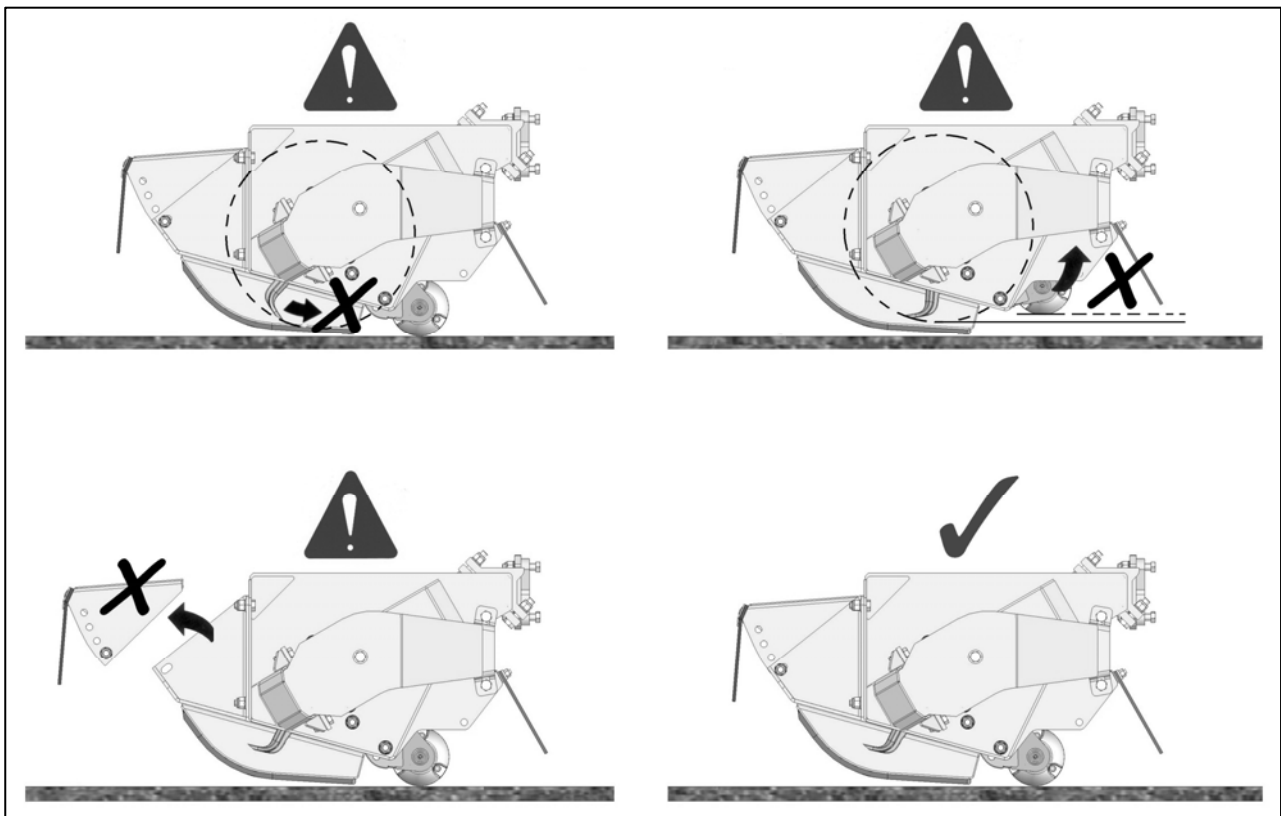

## HEDGE CUTTING – Upward Cutting

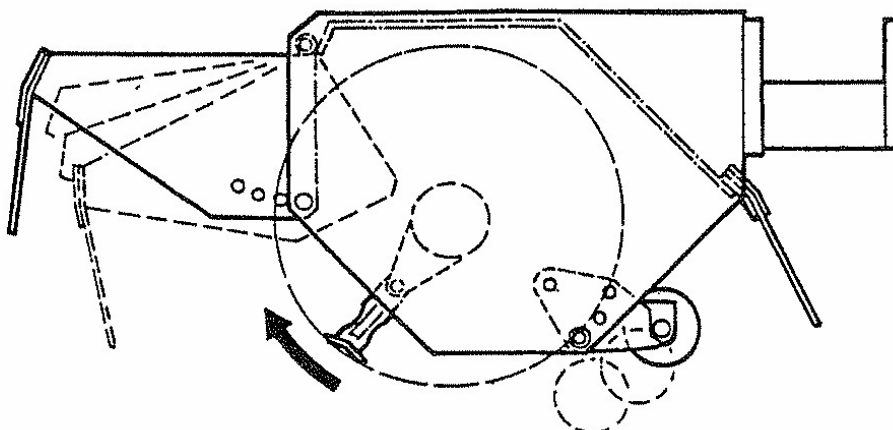

For normal trimming work on hedges the rotor should be set to cut with an upwards rotation – this produces a better finish to the work and demands lower power requirement. Front hood and rear flap must always be in position.

The roller should be set slightly higher than the rotor – i.e. in position 1 as shown on the previous roller position page.

The front hood has four height adjustment positions – the lowest possible position which allows the material to be cut to enter the head should always be used. Front flaps if fitted may be removed to aid entry of the material to be cut into the flail head.

**WARNING: Raising the front hood increases the possibility of debris escaping – never operate the machine with the front hood set any higher than is absolutely necessary.**

## HEDGE CUTTING – Downward Cutting

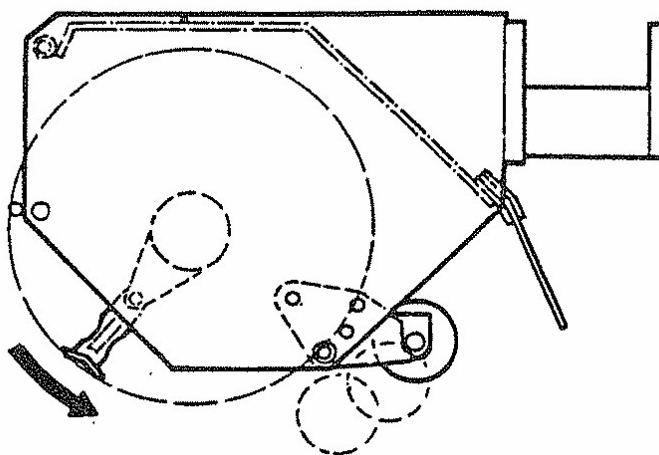

Where the size of the material to be cut makes it necessary for the front hood and carrier plates to be removed to allow the rotor to cut, the rotor must always be set to cut with downwards rotation – this results in a poorer finish to the work and demands higher power requirement.

The roller should be set slightly higher than the rotor – i.e. in position 1 as shown on the previous roller position page.

The rear flap must always remain in position to deflect the cut material downwards into the hedge. Because of the tendency to eject material out of the rear of the hood when downward cutting it is important that the rear flap is kept in good condition and replaced if excessive worn or damaged.

**WARNING: Do not remove guarding under any circumstances during operation.**

## TRACTOR FORWARD SPEED

---

The material being cut determines tractor forward speed. Forward speed can be as fast as that which allows the flail head sufficient time to cut the vegetation properly. Too fast a speed will be indicated by over frequent operation of the breakaway system, a fall off in tractor engine revs and a poor finish to the work leaving ragged uncut tufts and poorly mulched cuttings.

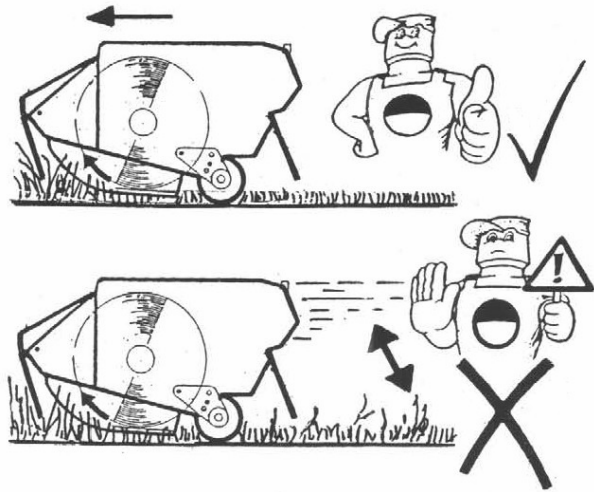

# HEDGE CUTTING PROCEDURE



## WARNING!

**Never cut on the blind side of the hedge**

It is impossible to see potential hazards or dangers and the position of the flail head may allow debris to be propelled through the hedge towards the tractor and the operator.

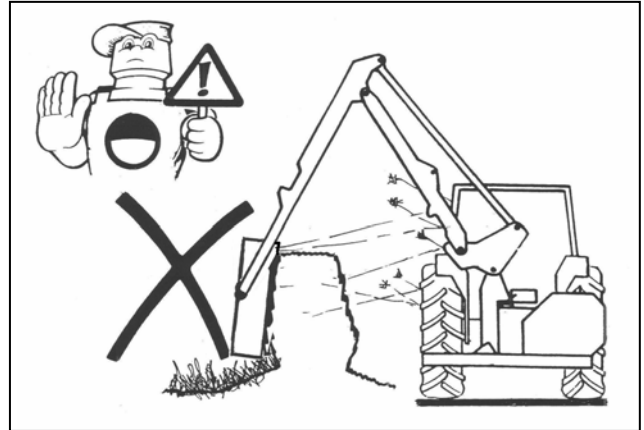

Cut the side and bottom of the field side first. This leaves the maximum thickness of hedge on the road side to prevent the possibility of debris being thrown through the hedge into the path of oncoming vehicles.

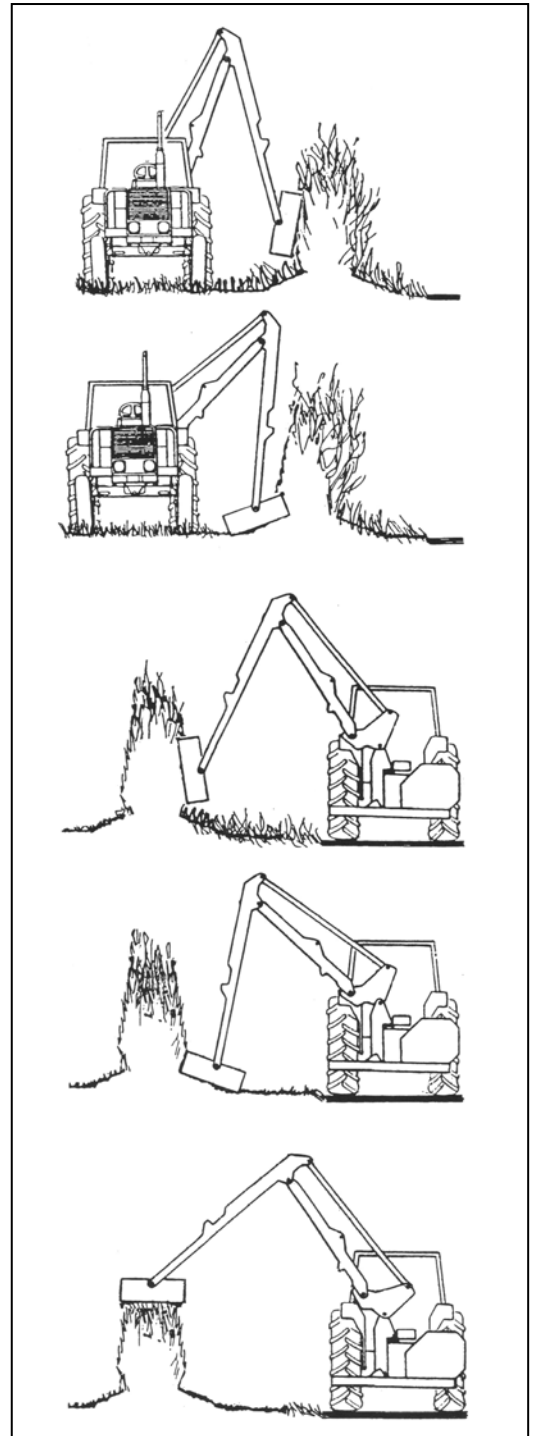

Cut the side and bottom of the road side.

Top cut the hedge to the height required.

## WIRE TRAP

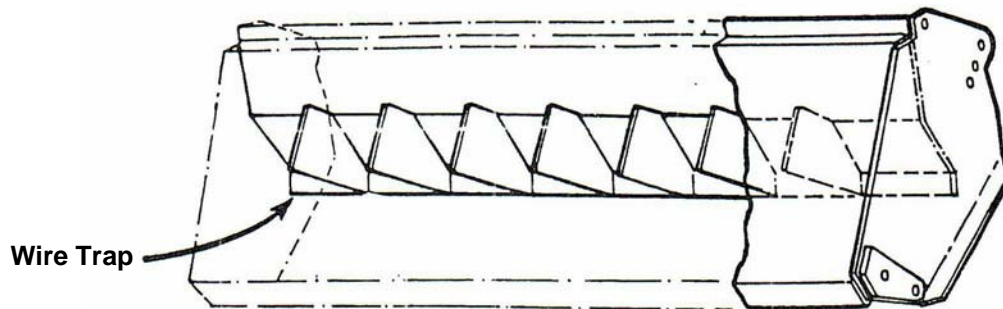

The flailhead is equipped with a 'wire cutting' edge welded into the underside – this plate should not be interfered with in any way. If wire becomes caught in the rotor the machine must be switched off immediately and the wire removed.

### Removing Wire

Select 'Rotor Off' and wait until the rotor has stopped turning completely.

Switch off the tractor and remove the starting key before attempting to remove the wire.

**WARNING:** Do not reverse the rotor in an attempt to unwind the wire.

## MAINTENANCE

Frequently inspect the rotor assembly for damaged or missing flails – Never operate or attempt to run the rotor with flails missing, imbalance will cause severe vibration and can rapidly damage the rotor shaft bearings. As an emergency measure, if a flail is broken off or missing, removal of an opposing flail on the opposite side of the rotor will retain the balance. Replace the flails at the earliest possible opportunity and always replace in opposite pairs. Never match up a new flail with a sharpened or damaged flail as the latter will be lighter thus causing imbalance of the rotor.

Blunt flails absorb more power and leave an untidy finish to the work. They should be sharpened on a grindstone or with a portable grinder periodically. Always wear protective gear when sharpening flails.

### IMPORTANT

On the first day of use with a new flailhead, nuts should be checked for tightness every hour and retightened if required. Thereafter they should be checked on a daily basis prior to use of the machine.

### Lubrication

Grease daily the points indicated in the illustration below.

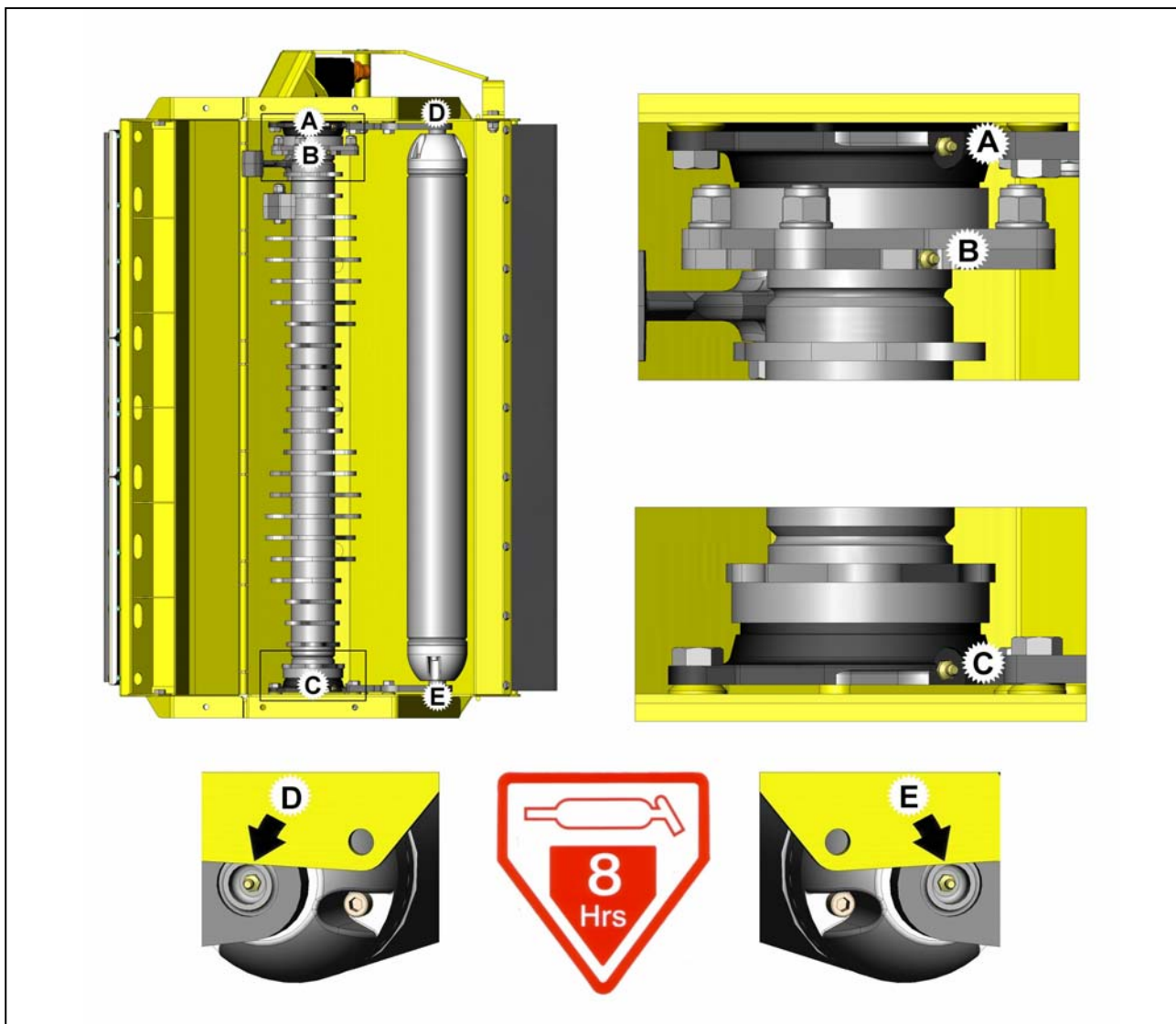
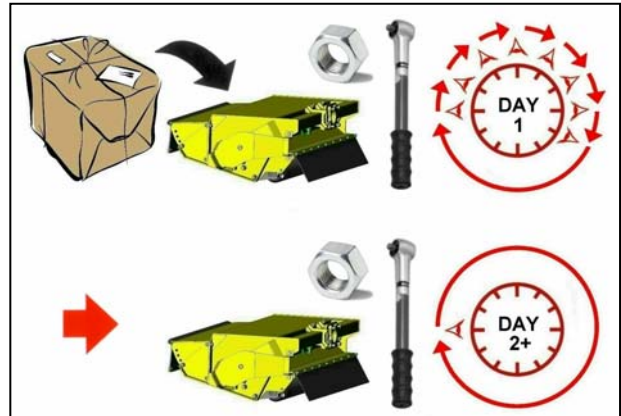



## ROTOR SHAFT ALIGNMENT

---

Rotor shaft hub failure can usually be attributed to rotor misalignment caused by distortion of the flailhead due to the hood or casing receiving a violent blow against an obstruction during work or by dropping the flail head heavily to the ground. These actions should, wherever possible, be avoided.

**Where rotor alignment is incorrect or when refitting or replacing rotor components it is imperative that the following procedure for re-assembly is adhered to:**

Procedure for re-assembly is as follows:-

1. Press the new bearing fully into the housing and then press the complete assembly onto the rotor shaft until the bearing inner race is firmly against the rotor shoulder.
2. Support the head off the ground in a vertical position. Offer up the complete rotor shaft into the casing, and locate the lower mounting bolts. Tighten the nuts sufficiently to take out all movement and then check the hole alignment at the top end of the casing. If the mounting bolts will not readily fit into place, release the lower bolts and shim between the casing boss and bearing housing until the top holes are aligned.
3. Locate the three top mounting bolts and then tighten the three lower bolts and nuts completely – *torque to a setting of approximately 162Nm (120 ft-lb.)*.
4. Check for clearance between the top bearing housing and casing, and completely shim all gaps before tightening the three mounting bolts to the same torque as above. If there is not clearance between the housing and casing, the bosses will need to be 'ground off' in order to provide clearance for the adding of shims. *Failure to shim all gaps will tend to draw the bearing from the shaft when the bolts are tightened.*

### **Note**

Two sizes of shim are available from McConnel; these are:

Part No. 8121043 for 0.4mm (.015")

Part No. 8121044 for 0.6mm (.025")

Alternatively thin spacing washers .2 may be used. The welded bosses in the casing may be of varying depths - this is a jiggling requirement during manufacture of the head and should not be regarded as a fault.

5. Finally, with the flail head horizontal, turn the rotor over by hand. There should be no binding or tight spots. Replace motor but do not bolt in place, when the rotor is rotated by hand the motor should not move. Movement up and down or side to side indicates a problem.

**Warning: Failure to correctly align the rotor shaft may result in the motor shaft breaking.**

6. The Coupling should be fitted on to the Motor and the nut tightened to a maximum torque setting of 80Nm (60 ft-lb.) - Do not exceed this value. Prior to the fitting of the motor, the hub and coupling splines should be liberally coated with Morris's K65MS high temperature grease, or equivalent. Experience has indicated that in addition to the pre-pack with Morris's K64MS grease supplied, greasing the rotor bearings, particularly the drive side, twice daily can considerably improve the longevity of the drive hub and coupling.

# Rotor Shaft Shim Fitment

**Rotor mis-aligned**

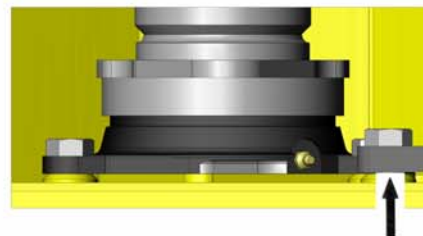
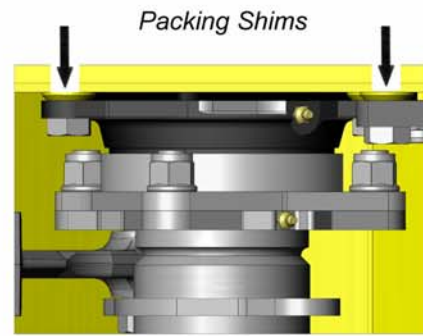
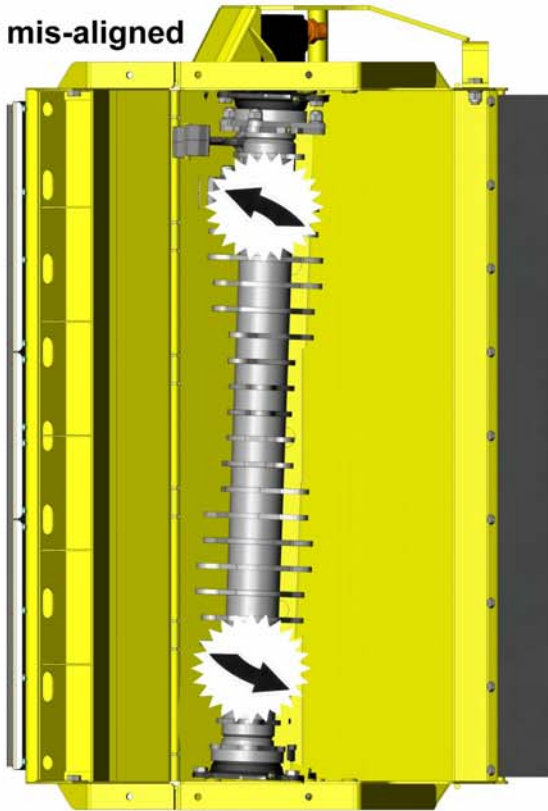

*Shim where required to adjust alignment*

**Rotor aligned**

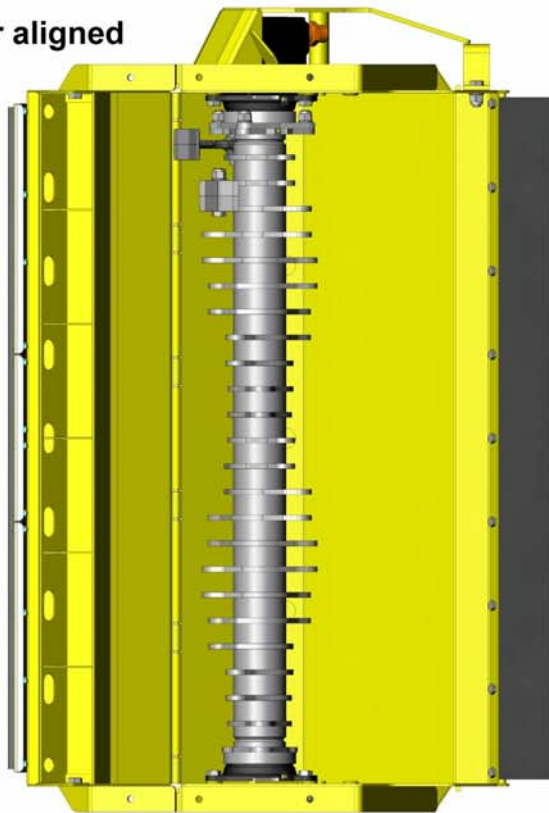





## McConnel Generic Parts Manual

*Generic parts manuals should be used as a general guide to the components used on the machine; to ensure accurate parts information for a specific machine please refer to the 'Interactive Parts Database' on our website which identifies the exact components used on the machine when it was manufactured based on the machine's unique serial number.*

*Direct access can be gained using the web address or QR code below.*  
<http://www.mcconnel.com/support/product-support/interactive-parts-database/>

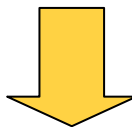

*Design improvements may have altered some of the parts listed in this manual; latest parts will always be supplied if they are interchangeable with earlier ones.*

# 1.2M SUPERCUT FLAILHEAD (CENTRE MOUNT)

Module(s): 7345800 (BSP), 7345801 (BSP), 7198817 (JIC)

# McCONEL

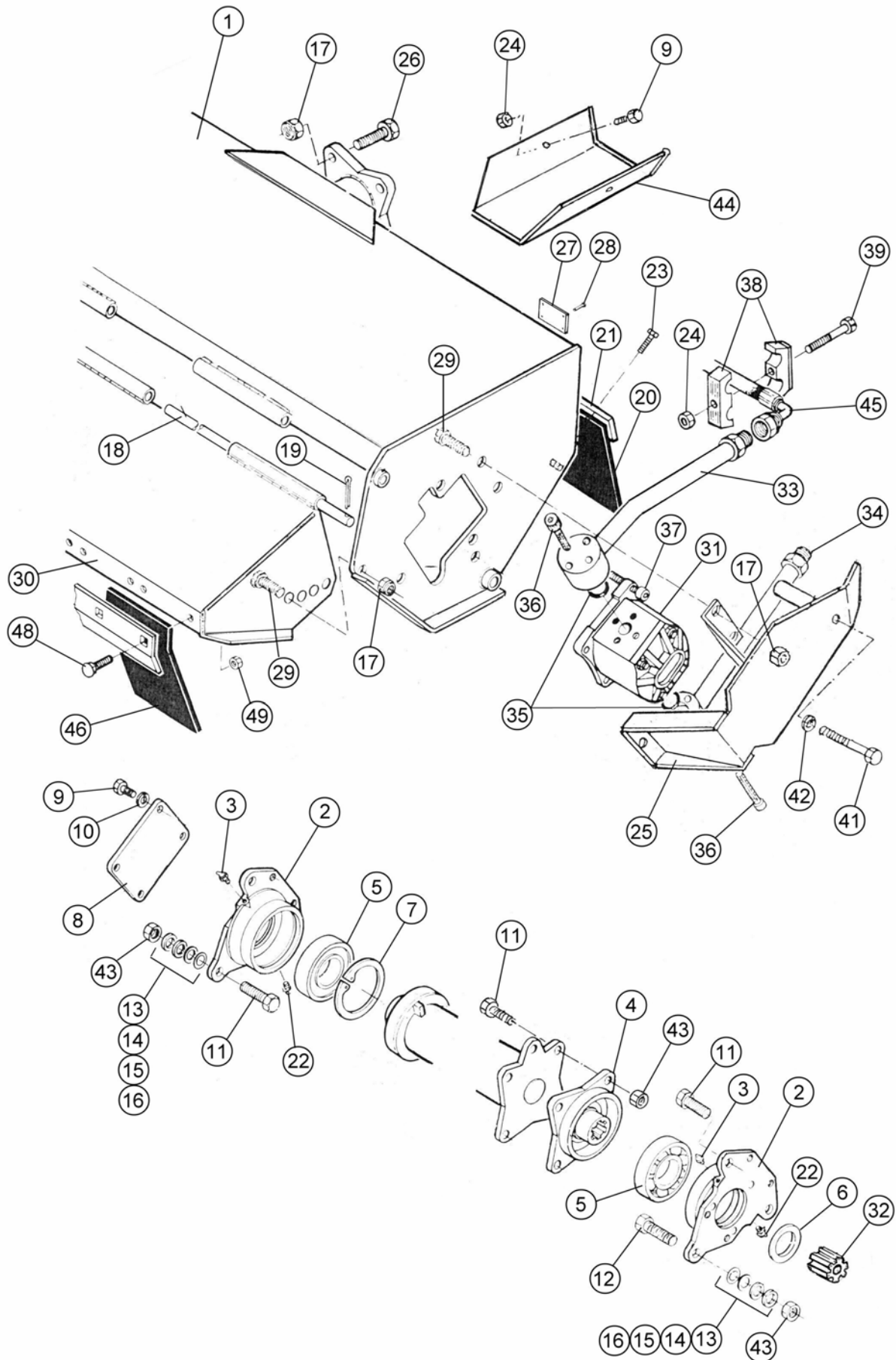

# 1.2M SUPERCUT FLAILHEAD (CENTRE MOUNT)

# McCONNEL

Module(s): 7345800 (BSP), 7345801 (BSP), 7198817 (JIC)

REF.	QTY.	PART No.	DESCRIPTION
		<b>7345800</b>	<b>1.2M CENTRE MOUNT S/CUT HEAD (BSP)</b>
		<b>7345801</b>	<b>1.2M CENTRE MOUNT S/CUT HEAD (BSP)</b>
		<b>7198817</b>	<b>1.2M CENTRE MOUNT S/CUT HEAD (JIC)</b>
1	1	7192388	FLAIL CASING
2	2	7190261	BEARING HOUSING
3	2	0901124	GREASER - ANGLED
4	1	7190571*	DRIVE HUB (* for replacement use 7190578)
5	2	0600018	BEARING
6	1	7190015	MOTOR LOCATING WASHER
7	2	7190022	INTERNAL CIRCLIP
8	1	7190444	COVER PLATE
9	4	9313045	SETSCREW
10	4	9100205	SPRING WASHER
11	3	0211166	BOLT - SPECIAL
12	5	0211146	BOLT - SPECIAL
13	as req.	8121044	SHIM - 0.24"
14	as req.	8121043	SHIM - 0.016"
15	as req.	7191099	SHIM - 2.5mm
16	as req.	7191098	SHIM - 1.5mm
17	18	0141006	SELF-LOCKING NUT
18	1	7191116	HOOD PIVOT PIN
19	1	9501406	SPLIT PIN
20	1	7191361	REAR FLAP
21	1	7191362	CLAMP STRIP
22	2	0901121	GREASER - STRAIGHT
23	12	9313055	SETSCREW
24	13	9143005	SELF-LOCKING NUT
25	1	42282.02	MOTOR COVER - <i>BSP Build</i>
	1	7191283	MOTOR COVER - <i>JIC Build</i>
26	4	0211186	BOLT - SPECIAL
27	1	1335246	SERIAL No. PLATE
28	4	7103230	POP RIVET
29	4	0311126	SETSCREW
30	1	7191352	FRONT HOOD
31	1	8301281	HYDRAULIC MOTOR
32	1	7190573	SPLINED DRIVE COUPLING
33	1	7190376	RIGID PIPE - UPPER
34	1	7190377	RIGID PIPE - LOWER
35	2	8600121	O RING
36	6	9300014	CAPSCREW
37	4	9300144	CAPSCREW
38	1	7190148	HOSE CLAMP (PAIR)
39	1	9213165	BOLT

# 1.2M SUPERCUT FLAILHEAD (CENTRE MOUNT)

Module(s): 7345800 (BSP), 7345801 (BSP), 7198817 (JIC)

# McCONEL

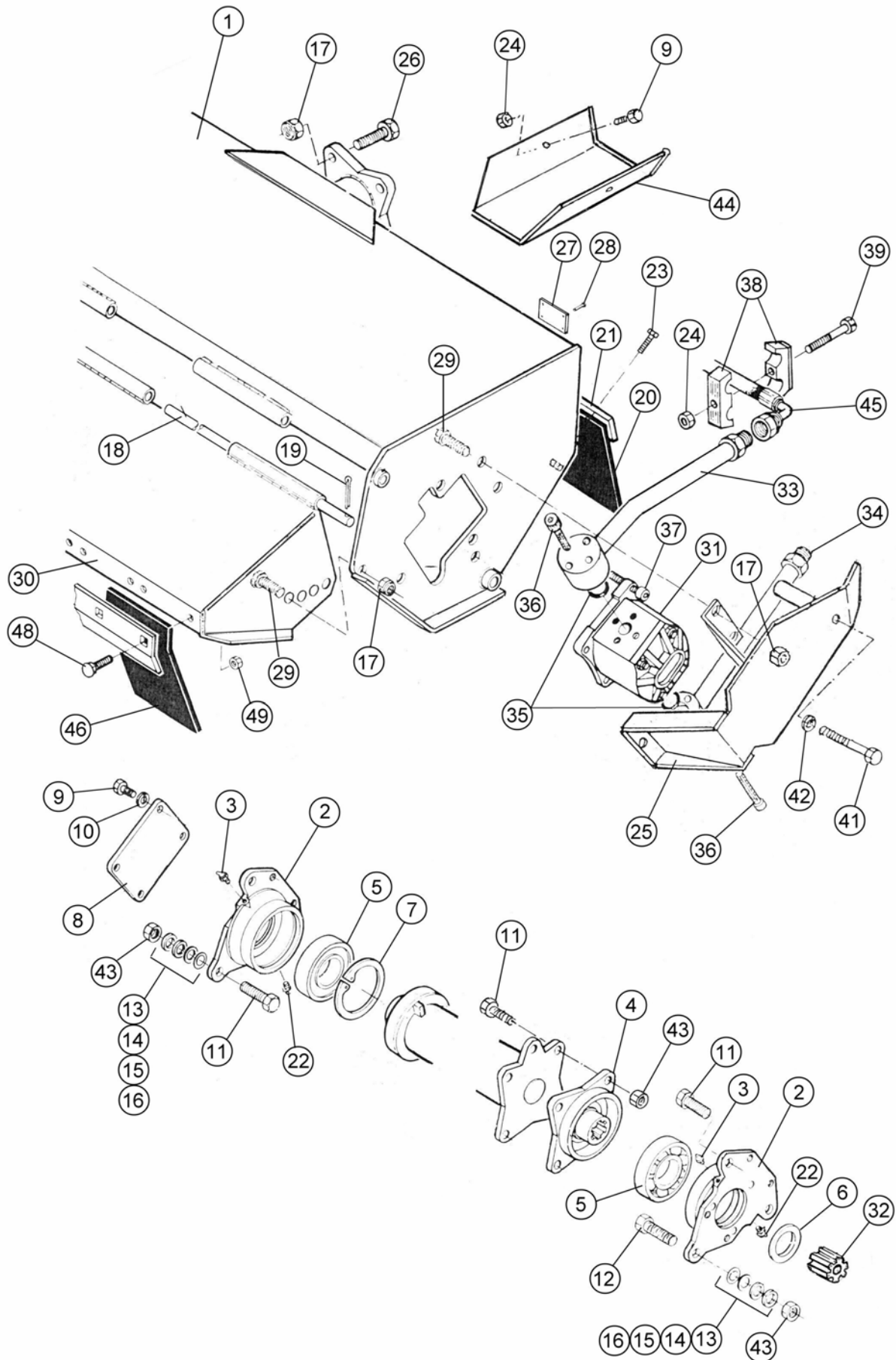

**1.2M SUPERCUT FLAILHEAD (CENTRE MOUNT)****McCONNEL**

Module(s): 7345800 (BSP), 7345801 (BSP), 7198817 (JIC)

<b>REF.</b>	<b>QTY.</b>	<b>PART No.</b>	<b>DESCRIPTION</b>
40	1	10.010.18	HOSE - 3/4" BSP FS/F90 x 900mm
	1	08.959.09	HOSE - 1.1/16" JIC FS/F90 x 900mm
41	1	0211446	BOLT
42	1	0100206	SPRING WASHER
43	4	0311126	SELF-LOCKING NUT
44	1	7198333	HOSE TRAY
45	1	8538015	HOSE - 3/4" BSP SF/F90 x 33"
	1	08.959.09	HOSE - 1.1/16" JIC FS/F90 x 900mm
		<b>7290375</b>	<b>FRONT FLAP KIT</b>
46	8	7290053	FRONT FLAP
47	1	7190304	CLAMP
48	16	9293054	BOLT
49	16	9143004	SELF-LOCKING NUT
		<b>8699236</b>	<b>MOTOR SEAL KIT</b>



# 1.2M ROTOR & FLAIL OPTIONS

**McCONEL**

Module(s): Rotor 7191382

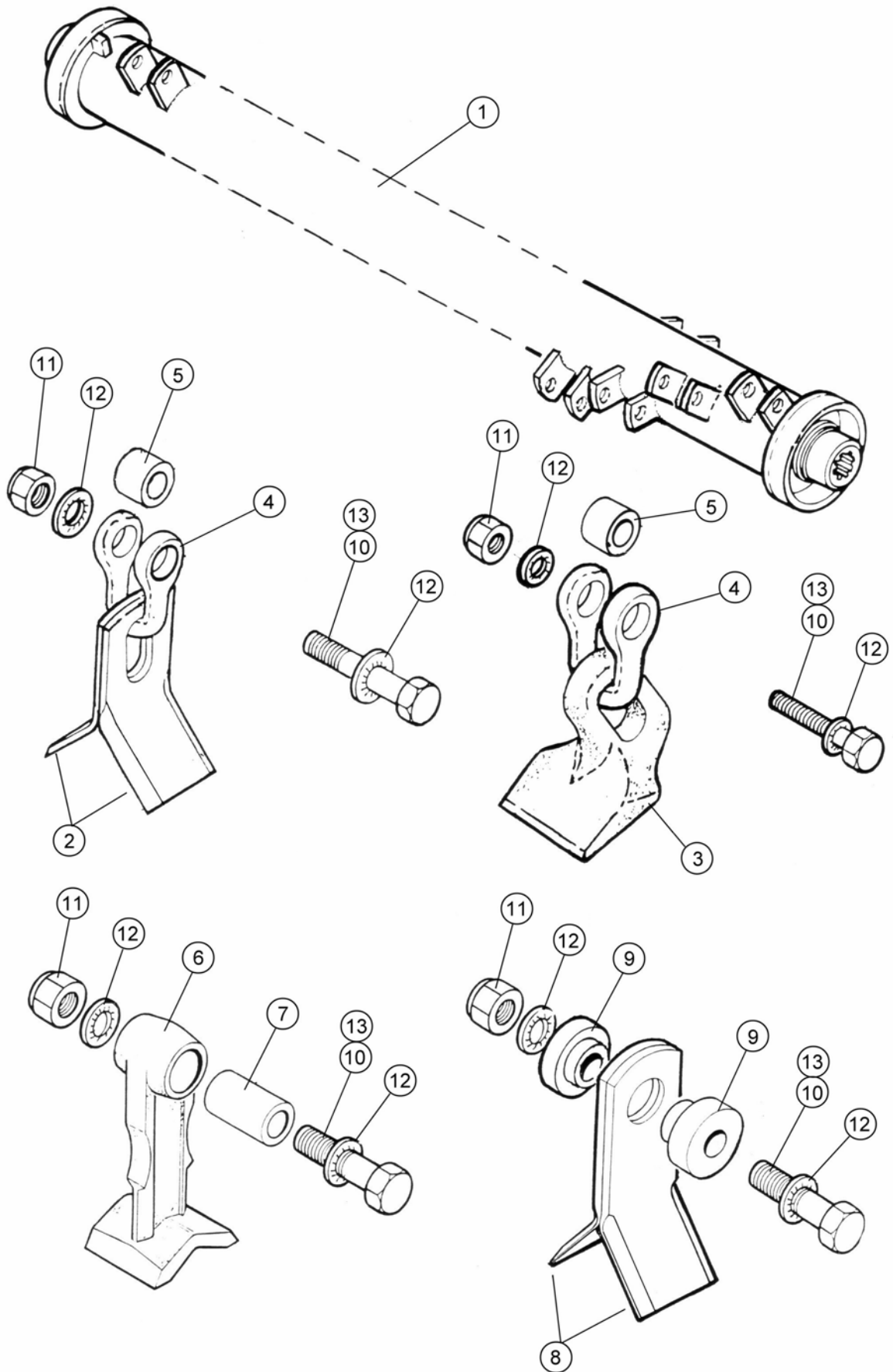

**1.2M ROTOR & FLAIL OPTIONS****McCONNEL**

Module(s): Rotor 7191382

<b>REF.</b>	<b>QTY.</b>	<b>PART No.</b>	<b>DESCRIPTION</b>
			<b>1.2M ROTOR &amp; FLAIL OPTIONS</b>
1	1	7191382	ROTOR - 1.2M
2	48	7190166	FLAIL
3	24	7190462	FLAIL
4	24	7191138	SHACKLE
5	24	7191139	SPACER
6	24	7191320	FLAIL
7	24	7191054	SPACER
8	48	7190315	FLAIL
9	48	7191095	BUSH
10	22	7191109	SPECIAL BOLT
11	24	0141005	SELF-LOCKING NUT
12	48	0100305	SHAKEPROOF WASHER
13*	2	7114082	SPECIAL BOLT

\* *Note: Items #13 used on end lugs only.*

# 1.2M ROLLER ASSEMBLY

**McCONNEL**

Module(s): 7198392

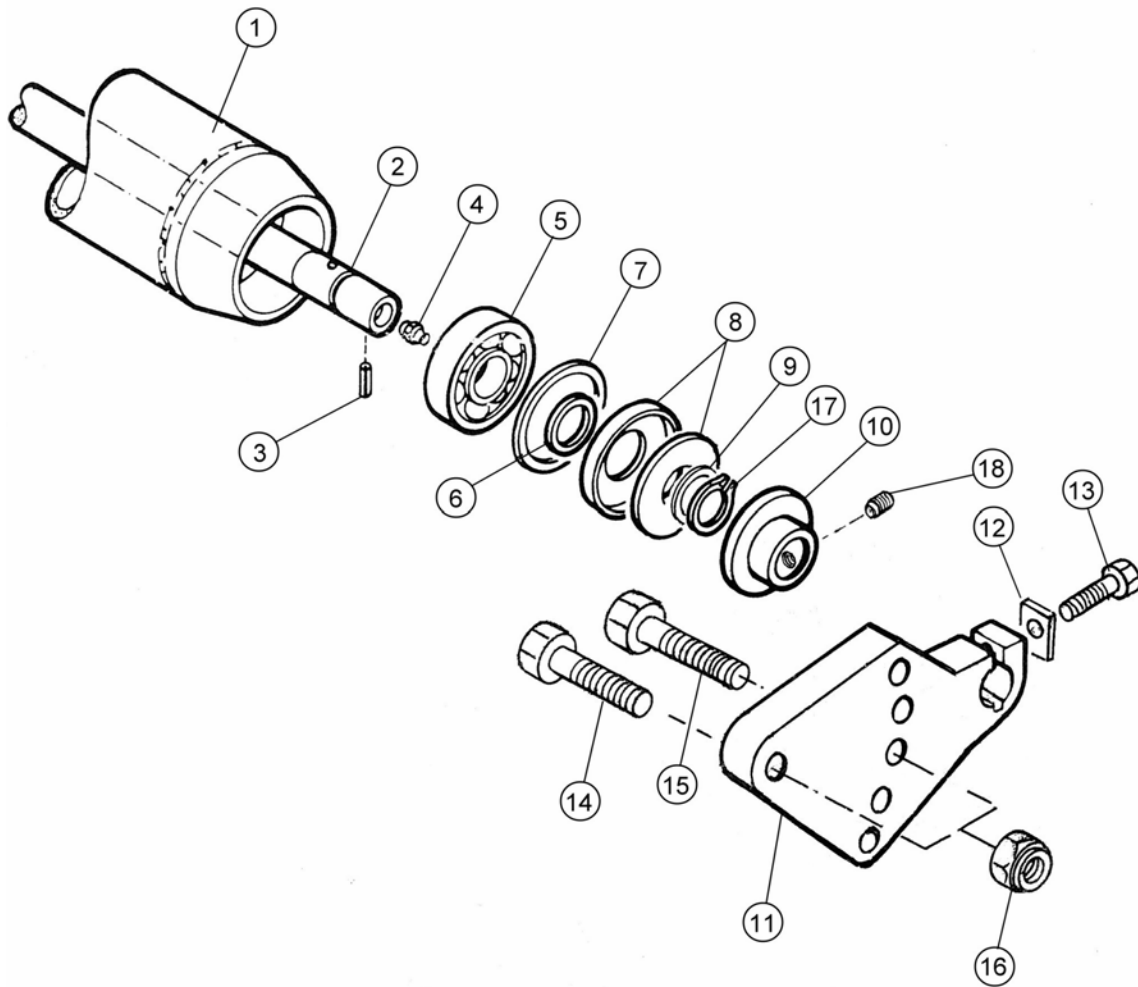

REF.	QTY.	PART No.	DESCRIPTION
		<b>7198392</b>	<b>ROLLER ASSEMBLY</b>
1	1	7191359	1.2M ROLLER
2	1	7191360	AXLE
3	1	0425408	SPRING DOWEL
4	2	0901121	GREASER - STRAIGHT
5	2	0600088	BEARING
6	2	7191092	SPACER WASHER - SMALL
7	2	7191093	SPACER WASHER - LARGE
8	2	7191091	SEALING WASHER SET
9	<i>as req'd</i>	7191107	ROLLER SHIM
10	2	7191285	ROLLER SPACER
11	2	7191378	ROLLER BRACKET
12	2	41777.01	TAB WASHER
13	2	0211165	BOLT
14	2	0211166	SETSCREW
15	2	0211186	SETSCREW
16	4	0141006	SELF-LOCKING NUT
17	2	0401225	EXTERNAL CIRCLIP
18	1	9300146	GRUBSCREW

# FRONT FLAP KIT (Option)

**McCONNEL**

Module(s): 7290375

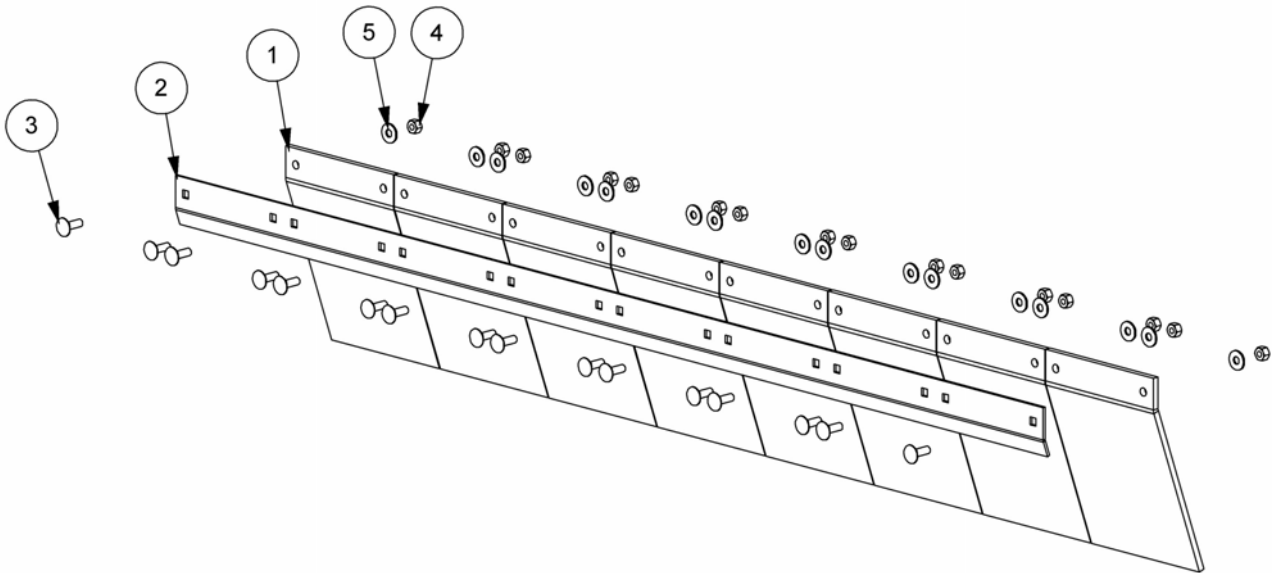

REF.	QTY.	PART No.	DESCRIPTION
		<b>7290375</b>	<b>FRONT FLAP KIT</b>
1	8	7290053	FRONT FLAP
2	1	7190304	CLAMP STRIP
3	16	9293054	CUP HEAD SCREW
4	16	9143004	SELF-LOCKING NUT
5	16	9100104	FLAT WASHER

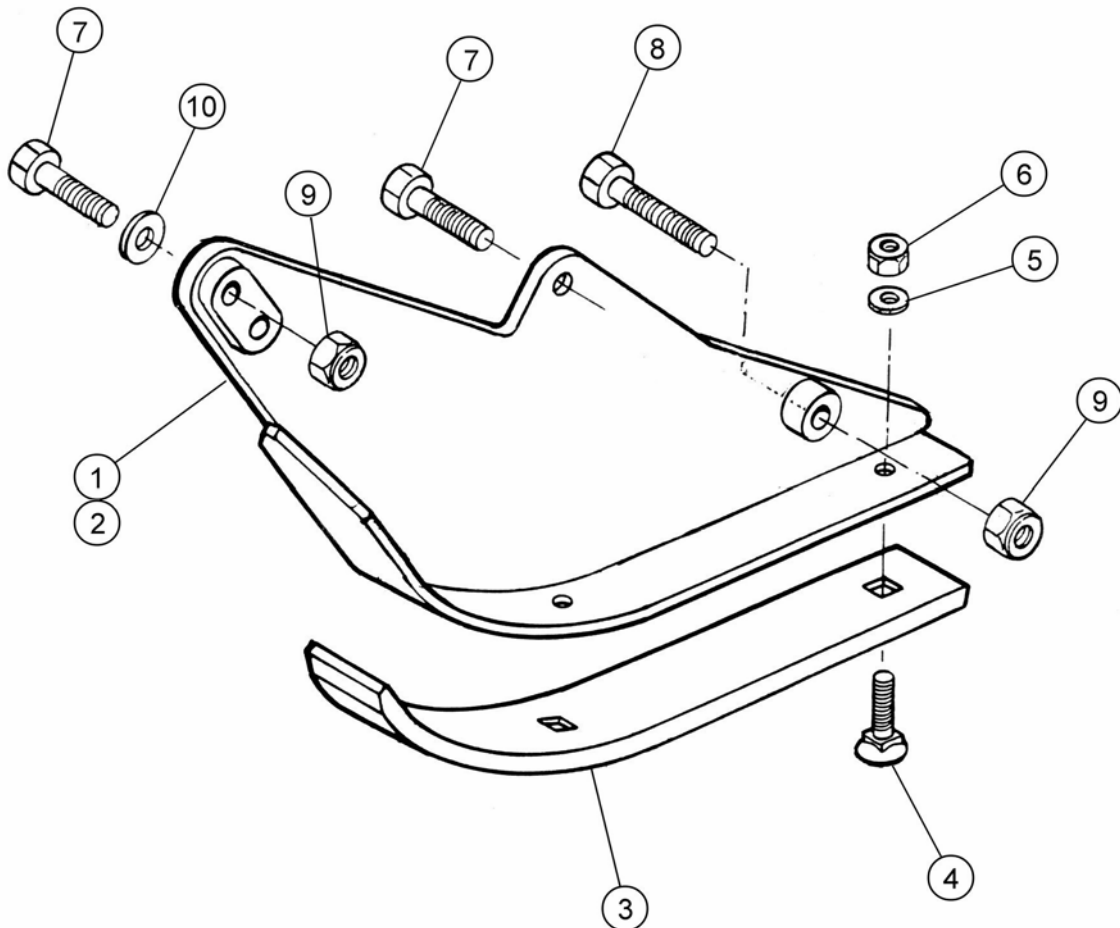

REF.	QTY.	PART No.	DESCRIPTION
		<b>7198374</b>	<b>SKID KIT</b>
1	1	7198368	SKID - L/H
2	1	7198369	SKID - R/H ( <i>not illustrated</i> )
3	2	7290391	WEAR SKID
4	6	6012034	TINE BOLT
5	6	0100104	PLAIN WASHER
6	6	0142004	SELF-LOCKING NUT
7	4	0311106	SETSCREW
8	2	0311126	SETSCREW
9	4	0141006	SELF-LOCKING NUT
10	6	0100106	PLAIN WASHER

DECAL KIT

Module(s): 7191368

**McCONNEL**

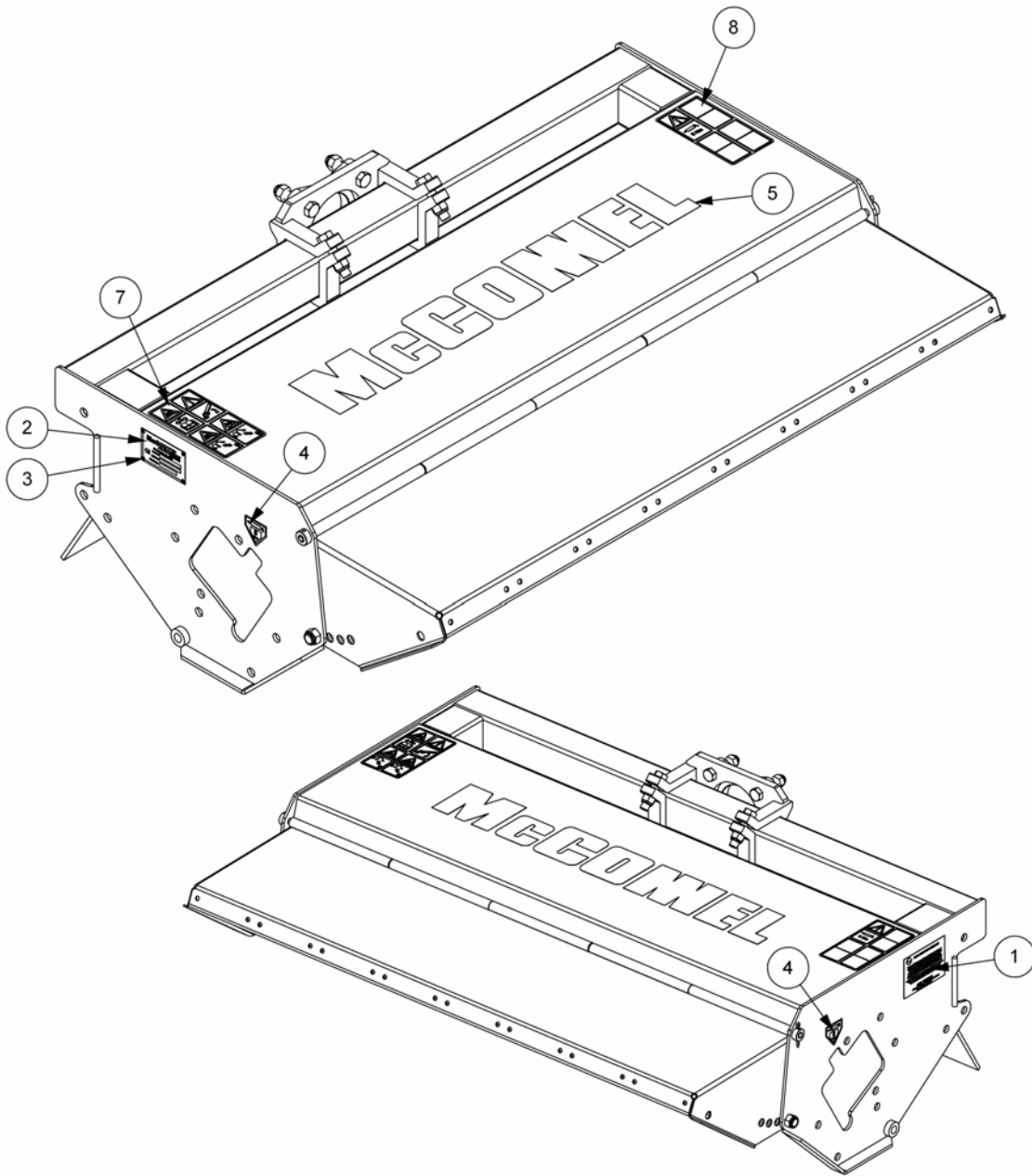

REF.	QTY.	PART No.	DESCRIPTION
		<b>7191368</b>	<b>FLAILHEAD DECAL KIT</b>
1	1	1290392	DECAL - PARTS INFORMATION
2	1	1335246	SERIAL No. PLATE
3	4	7103230	POP RIVET
4	2	09.810.01	DECAL - GREASE (8 HRS)
5	1	1290527	DECAL - MCCONNEL
6	1	1290462	DECAL - FLAILHEAD HAZARD
7	1	09.821.35	DECAL - COMBINED EURO DECAL
8	1	1290738	DECAL - FLAILHEAD





McConnel Limited, Temeside Works, Ludlow, Shropshire SY8 1JL. England.  
Telephone: 01584 873131. Facsimile: 01584 876463. [www.mcconnel.com](http://www.mcconnel.com)