

Publication 587  
March 2009  
Part No. 41571.87  
Revised: 20.11.17

# ROTARY HEAD 1.2M & 1.5M HEAVY DUTY



Operator & Parts Manual



# IMPORTANT

## VERIFICATION OF WARRANTY REGISTRATION



### Dealer Warranty Information & Registration Verification

It is imperative that the selling dealer registers this machine with McConnel Limited before delivery to the end user – failure to do so may affect the validity of the machine warranty.

To register machines; log onto <https://my.mcconnel.com> and select 'Machine Registration' which can be found in the 'Warranty' section of the site. **Confirm to the customer that the machine has been registered by completing the verification form below.**

<b>Registration Verification</b>	Serial No. <input type="text"/>
Dealer Name: .....	
Dealer Address: .....	
Customer Name: .....	
Date of Warranty Registration: ...../...../..... Dealer Signature: .....	

### Note to Customer / Owner

Please ensure the section above has been completed and signed by the dealer to verify your machine has been registered with McConnel Limited.

**IMPORTANT:** During the initial 'bedding in' period of a new machine it is the customer's responsibility to regularly inspect all nuts, bolts and hose connections for tightness and re-tighten if required. New hydraulic connections occasionally weep small amounts of oil as the seals and joints settle in – where this occurs it can be cured by re-tightening the connection – *refer to torque settings chart below*. The tasks stated above should be performed on an hourly basis during the first day of work and at least daily thereafter as part of the machine's general maintenance procedure.

CAUTION: DO NOT OVER TORQUE HYDRAULIC FITTINGS AND HOSES

### Torque Settings for Hydraulic Fittings

Hydraulic Hose Ends		
BSP	Setting	Metric
1/4"	18 Nm	19 mm
3/8"	31 Nm	22 mm
1/2"	49 Nm	27 mm
5/8"	60 Nm	30 mm
3/4"	80 Nm	32 mm
1"	125 Nm	41 mm
1.1/4"	190 Nm	50 mm
1.1/2"	250 Nm	55 mm
2"	420 Nm	70 mm

Port Adaptors with Bonded Seals		
BSP	Setting	Metric
1/4"	34 Nm	19 mm
3/8"	47 Nm	22 mm
1/2"	102 Nm	27 mm
5/8"	122 Nm	30 mm
3/4"	149 Nm	32 mm
1"	203 Nm	41 mm
1.1/4"	305 Nm	50 mm
1.1/2"	305 Nm	55 mm
2"	400 Nm	70 mm



# WARRANTY POLICY

## WARRANTY REGISTRATION

All machines must be registered, by the selling dealer with McConnel Ltd, before delivery to the end user. On receipt of the goods it is the buyer's responsibility to check that the Verification of Warranty Registration in the Operator's Manual has been completed by the selling dealer.

### 1. LIMITED WARRANTIES

- 1.01. *All mounted machines supplied by McConnel Ltd are warranted to be free from defects in material and workmanship from the date of sale to the original purchaser for a period of 12 months, unless a different period is specified.  
All Self Propelled Machines supplied by McConnel Ltd are warranted to be free from defects in material and workmanship from the date of sale to the original purchaser for a period of 12 months or 1500 hours. Engine warranty will be specific to the Manufacturer of that unit.*
- 1.02. *All spare parts supplied by McConnel Ltd and purchased by the end user are warranted to be free from defects in material and workmanship from the date of sale to the original purchaser for a period of 6 months. All parts warranty claims must be supported by a copy of the failed part invoice to the end user. We cannot consider claims for which sales invoices are not available.*
- 1.03. *The warranty offered by McConnel Ltd is limited to the making good by repair or replacement for the purchaser any part or parts found, upon examination at its factory, to be defective under normal use and service due to defects in material or workmanship. Returned parts must be complete and unexamined. Pack the component(s) carefully so that any transit damage is avoided. All ports on hydraulic items should be drained of oil and securely plugged to prevent seepage and foreign body ingress. Certain other components, electrical items for example, may require particular care when packing to avoid damage in transit.*
- 1.04. *This warranty does not extend to any product from which McConnel Ltd's serial number plate has been removed or altered.*
- 1.05. *The warranty policy is valid for machines registered in line with the terms and conditions detailed and on the basis that the machines do not extend a period of 24 months or greater since their original purchase date, that is the original invoice date from McConnel Limited.  
Machines that are held in stock for more than 24 months cannot be registered for warranty.*
- 1.06. *This warranty does not apply to any part of the goods, which has been subjected to improper or abnormal use, negligence, alteration, modification, fitment of non-genuine parts, accident damage, or damage resulting from contact with overhead power lines, damage caused by foreign objects (e.g. stones, iron, material other than vegetation), failure due to lack of maintenance, use of incorrect oil or lubricants, contamination of the oil, or which has served its normal life. This warranty does not apply to any expendable items such as blades, belts, clutch linings, filter elements, flails, flap kits, skids, soil engaging parts, shields, guards, wear pads, pneumatic tyres or tracks.*
- 1.07. *Temporary repairs and consequential loss - i.e. oil, downtime and associated parts are specifically excluded from the warranty.*
- 1.08. *Warranty on hoses is limited to 12 months and does not include hoses which have suffered external damage. Only complete hoses may be returned under warranty, any which have been cut or repaired will be rejected.*
- 1.09. *Machines must be repaired immediately a problem arises. Continued use of the machine after a problem has occurred can result in further component failures, for which McConnel Ltd cannot be held liable, and may have safety implications.*
- 1.10. *If in exceptional circumstances a non McConnel Ltd part is used to effect a repair, warranty reimbursement will be at no more than McConnel Ltd's standard dealer cost for the genuine part.*

- 1.11. *Except as provided herein, no employee, agent, dealer or other person is authorised to give any warranties of any nature on behalf of McConnell Ltd.*
- 1.12. *For machine warranty periods in excess of 12 months the following additional exclusions shall apply:*
  - 1.12.1. *Hoses, exposed pipes and hydraulic tank breathers.*
  - 1.12.2. *Filters.*
  - 1.12.3. *Rubber mountings.*
  - 1.12.4. *External electric wiring.*
  - 1.12.5. *Bearings and seals*
  - 1.12.6. *External Cables, Linkages*
  - 1.12.7. *Loose/Corroded Connections, Light Units, LED's*
  - 1.12.8. *Comfort items such as Operator Seat, Ventilation, Audio Equipment*
- 1.13. *All service work, particularly filter changes, must be carried out in accordance with the manufacturer's service schedule. Failure to comply will invalidate the warranty. In the event of a claim, proof of the service work being carried out may be required.*
- 1.14. *Repeat or additional repairs resulting from incorrect diagnosis or poor quality previous repair work are excluded from warranty.*

***NB Warranty cover will be invalid if any non-genuine parts have been fitted or used. Use of non-genuine parts may seriously affect the machine's performance and safety. McConnell Ltd cannot be held responsible for any failures or safety implications that arise due to the use of non-genuine parts.***

## **2. REMEDIES AND PROCEDURES**

- 2.01. *The warranty is not effective unless the Selling Dealer registers the machine, via the McConnell web site and confirms the registration to the purchaser by completing the confirmation form in the operator's manual.*
- 2.02. *Any fault must be reported to an authorised McConnell Ltd dealer as soon as it occurs. Continued use of a machine, after a fault has occurred, can result in further component failure for which McConnell Ltd cannot be held liable.*
- 2.03. *Repairs should be undertaken within two days of the failure. Claims submitted for repairs undertaken more than 2 weeks after a failure has occurred, or 2 days after the parts were supplied will be rejected, unless the delay has been authorised by McConnell Ltd. Please note that failure by the customer to release the machine for repair will not be accepted as a reason for delay in repair or submitting warranty claims.*
- 2.04. *All claims must be submitted, by an authorised McConnell Ltd Service Dealer, within 30 days of the date of repair.*
- 2.05. *Following examination of the claim and parts, McConnell Ltd will pay, at their discretion, for any valid claim the invoiced cost of any parts supplied by McConnell Ltd and appropriate labour and mileage allowances if applicable.*
- 2.06. *The submission of a claim is not a guarantee of payment.*
- 2.07. *Any decision reached by McConnell Ltd. is final.*

## **3. LIMITATION OF LIABILITY**

- 3.01. *McConnell Ltd disclaims any express (except as set forth herein) and implied warranties with respect to the goods including, but not limited to, merchantability and fitness for a particular purpose.*
- 3.02. *McConnell Ltd makes no warranty as to the design, capability, capacity or suitability for use of the goods.*
- 3.03. *Except as provided herein, McConnell Ltd shall have no liability or responsibility to the purchaser or any other person or entity with respect to any liability, loss, or damage caused or alleged to be caused directly or indirectly by the goods including, but not limited to, any indirect, special, consequential, or incidental damages resulting from the use or operation of the goods or any breach of this warranty. Notwithstanding the above limitations and warranties, the manufacturer's liability hereunder for damages incurred by the purchaser or others shall not exceed the price of the goods.*
- 3.04. *No action arising out of any claimed breach of this warranty or transactions under this warranty may be brought more than one (1) year after the cause of the action has occurred.*

#### **4. MISCELLANEOUS**

- 4.01. McConnel Ltd may waive compliance with any of the terms of this limited warranty, but no waiver of any terms shall be deemed to be a waiver of any other term.*
- 4.02. If any provision of this limited warranty shall violate any applicable law and is held to be unenforceable, then the invalidity of such provision shall not invalidate any other provisions herein.*
- 4.03. Applicable law may provide rights and benefits to the purchaser in addition to those provided herein.*

---

*McConnel Limited*



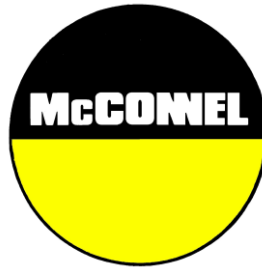

*For Safety and Performance...*

**ALWAYS READ THE BOOK FIRST**

**McCONEL LIMITED**

**Temeside Works  
Ludlow  
Shropshire  
England**

**Telephone: +44 (0)1584 873131  
www.mcconel.com**

---

**- NOISE STATEMENT -**

The equivalent daily personal noise exposure from this machine measured at the operators' ear is within the range 78 – 85 dB, these figures apply to a normal distribution of use where the noise fluctuates between zero and maximum. The figures assume that the machine is fitted to a tractor with a 'quiet' cab with the windows closed in a generally open environment. We recommend that the windows are kept closed. With the cab rear window open the equivalent daily personal noise exposure will increase to a figure within the range 82 – 88 dB. At an equivalent daily noise exposure level of 85 – 90 dB ear protection is recommended and must always be used if any window is left open.



Operating, servicing and maintaining this equipment can expose you to chemicals including gasoline, diesel fuel, lubricants, petroleum products, engine exhaust, carbon monoxide, and phthalates, which are known to the State of California to cause cancer and birth defects or other reproductive harm. To minimize exposure, avoid breathing exhaust, do not idle the engine except as necessary, service your vehicle in a well-ventilated area and wear gloves or wash your hands frequently when servicing your vehicle. Battery posts, terminals and related accessories contain lead and lead compounds, chemicals known to the state of California to cause cancer, birth defects or other reproductive harm. For more information go to [www.P65Warnings.ca.gov](http://www.P65Warnings.ca.gov). This website, operated by California's Office of Environmental Health Hazard Assessment, provides information about these chemicals and how individuals may be exposed to them.





# CONTENTS

---

Page No.

## **Operator Section**

General Information	2
Specifications	3
Component Location & Identification	3
Safety Information	4
Vehicle Preparation	8
Operation	9
Transportation	13
Maintenance	13

## **Parts Section**

Head Casing Assembly – <i>1.2m Models</i>	16
Head Casing Assembly – <i>1.5m Models</i>	18
Chain Guard Assembly – <i>1.2m Models</i>	20
Chain Guard Assembly – <i>1.5m Models</i>	21
Pivoting Mounting Bracket	22
Bearing Unit	23
Piston Motor – <i>1.2m Models</i>	24
Gear Motor – <i>1.2m Models</i>	25
Gear Motor – <i>1.5m Models</i>	26
Cutting Chain Assembly (Heavy Duty) – <i>1.2m Models</i>	27
Cutting Chain Assembly (Standard Duty) – <i>1.5m Models</i>	28
Cutting Chain Assembly (Heavy Duty) – <i>1.5m Models</i>	29
Blade Bar Assembly – <i>1.2m Models</i>	30
Blade Bar Assembly – <i>1.5m Models</i>	31
Hydraulic Installation – <i>1.2m Gear Models</i>	32
Hydraulic Installation – <i>1.2m Piston Models</i>	34
Hydraulic Installation – <i>1.5m Piston Models</i>	36
Hydraulic Ram Assembly	38
Stop Module	39
Decal Kit – <i>1.2m Models</i>	40
Decal Kit – <i>1.5m Models</i>	41

## GENERAL INFORMATION

---

Read this manual before fitting or operating this equipment. Whenever any doubt exists contact your dealer or the McConnel Service Department for assistance.

Always use 'Genuine McConnel Parts' on McConnel machinery and accessories.

### DEFINITIONS:

The following definitions apply throughout this manual:

### WARNING:

An operating procedure, technique etc., which can result in personal injury or loss of life if not observed carefully.

### CAUTION:

An operating procedure, technique etc., which can result in the damage of either machine or equipment if not observed carefully.

### NOTE:

An operating procedure, technique etc. which is considered essential to emphasise.

### LEFT & RIGHT HAND:

This term is applicable to the machine when it is fitted to the tractor and viewed from the rear. This also applies to tractor references.

Record the serial number of your machine on this page and always quote this number when ordering spares. Whenever information concerning the machine is requested remember to also state the type of tractor to which it is fitted.

MACHINE SERIAL NUMBER:

INSTALLATION DATE:

MODEL DETAILS:

DEALER NAME & ADDRESS:

DEALER TELEPHONE NUMBER:

### NOISE STATEMENT

*The equivalent daily personal noise exposure from this machine, measured at the operators' ear, is within the range 78 – 85 DB. These figures apply to a normal distribution of use where the noise fluctuates between zero and maximum. The figures assume that the machine is fitted to a tractor with a quiet cab with the windows closed in a generally open environment. We recommend that the windows are kept closed. With the cab rear window open the equivalent daily personal noise exposure will increase to a figure within the range 82 – 88 DB. At equivalent daily noise exposure levels of between 85 and 90 DB, ear protection is recommended, it should be used if any window is left open.*

## SPECIFICATIONS

Specifications	RH1200	RH1500
Working Width	1.2m (48")	1.5m (60")
Choice of Cutting Units	3 x Ø13mm Chains or D/Edge Blade Bar	3 x Ø10mm Chains or D/Edge Blade Bar
Length	1.7m (58")	2.0m (78")
Width	1.6m (63")	1.9m (75")
Height	0.62m – 0.67m (24.5" – 26")	0.62m – 0.67m (24.5" – 26")
Deck Material	Domex 700MC	Domex 700MC
Side Wall Thickness	6mm (0.23")	6mm (0.23")
Safety Guarding	Heavy Duty Overlapping Chain Guards	Heavy Duty Overlapping Chain Guards
Height Adjustment	Adjustable Skids	Adjustable Skids
Cutting Height	100mm, 125mm or 150mm (4", 5" or 6")	100mm, 125mm or 150mm (4", 5" or 6")
Front Hood	Hydraulically Adjusted (110° action)	Hydraulically Adjusted (110° action)
Mounting Attachment	80x80x270 RHS	80x80x270 RHS
Pivot	Fully Floating +7°	Fully Floating ±7°
Hydraulic Flow	125 l/min	125 l/min
Hydraulic Pressure (Max)	210Bar	210Bar
Motor Type	Gear or Piston	Gear
<b>Options</b>		
Cutting Unit	-	Heavy Duty Ø13mm Chain Cutting Unit
Rubber Flaps	-	Light Duty Front & Rear Rubber Flaps

## COMPONENT LOCATION & IDENTIFICATION

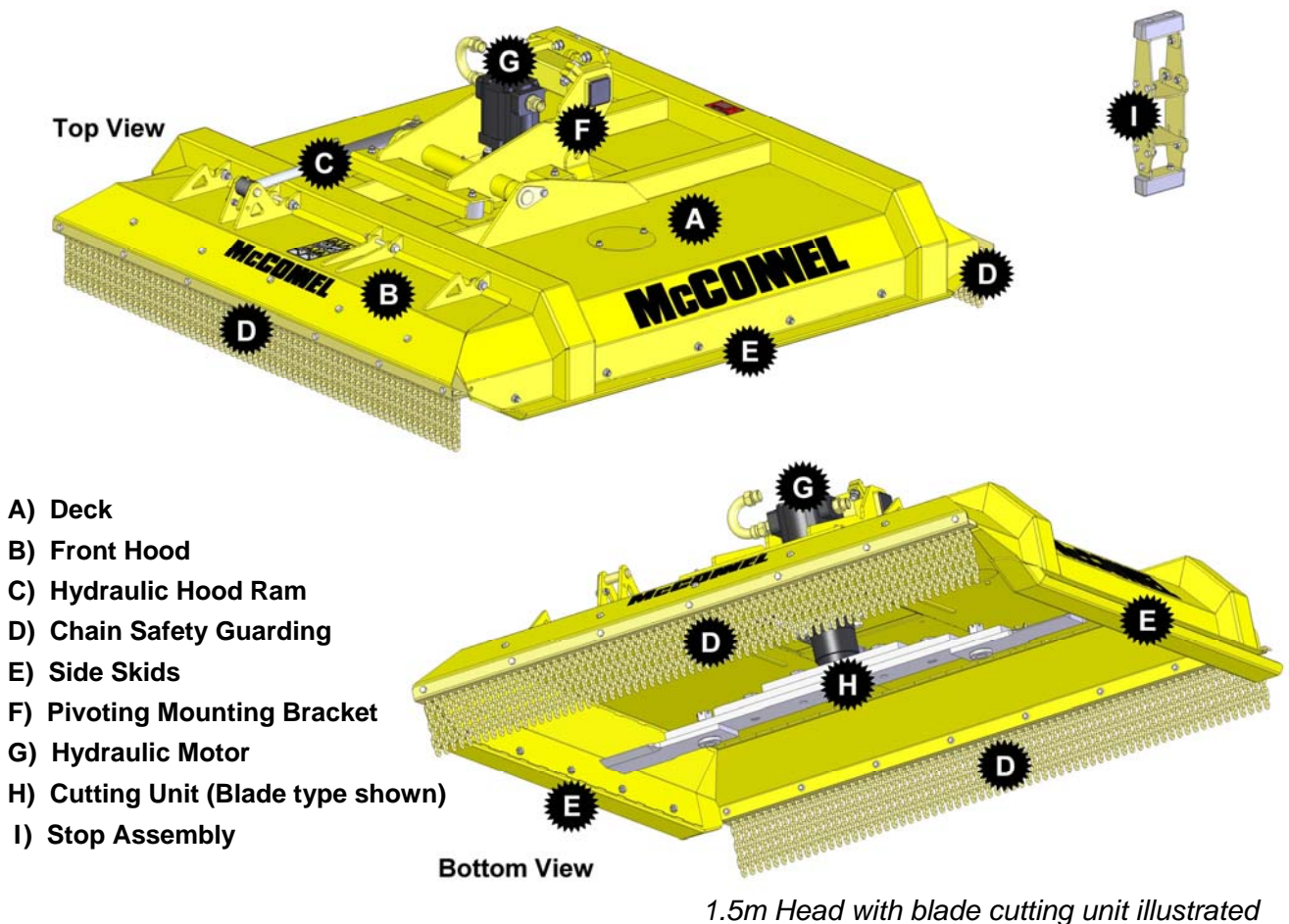



### SAFETY INFORMATION



This component / accessory is primarily designed for fitment to McConnel Power Arm Hedge and Grass Cutters, therefore all safety aspects for this component relate to the safe use of those machines and will be stated in the safety section of its operation manual. A copy of the same safety information is provided below in order to reiterate and refresh your memory.

This machine has the potential to be extremely dangerous, in the wrong hands it can kill or maim. It is therefore imperative that the owner, and the operator of this machine, read the following section to ensure that they are both fully aware of the dangers that do, or may exist, and their responsibilities surrounding its use.

The operator of this machine is responsible not only for their own safety but equally for the safety of others who may come into the close proximity of the machine, as the owner you are responsible for both.

#### **POTENTIAL SIGNIFICANT DANGERS ASSOCIATED WITH THE USE OF A MACHINE:**

- ▲ *Being hit by debris thrown by rotating components.*
- ▲ *Being hit by machine parts ejected through damage during use.*
- ▲ *Being caught on a rotating power take-off (PTO) shaft.*
- ▲ *Being caught in other moving parts i.e.: belts, pulleys and cutting heads.*
- ▲ *Electrocution from Overhead Power Lines (by contact with or 'flashover' from).*
- ▲ *Being hit by cutting heads or machine arms as they move.*
- ▲ *Becoming trapped between tractor and machine when hitching or unhitching.*
- ▲ *Tractor overbalancing when machine arm is extended.*
- ▲ *Injection of high-pressure oil from hydraulic hoses or couplings.*
- ▲ *Machine overbalancing when freestanding (out of use).*
- ▲ *Road traffic accidents due to collision or debris on the road.*

## **BEFORE USING A MACHINE YOU MUST:**

- ▲ *Ensure you read all sections of the operator handbook.*
- ▲ *Ensure the operator is, or has been, properly trained to use the machine.*
- ▲ *Ensure the operator has been issued with and reads the operator handbook.*
- ▲ *Ensure the operator understands and follows the instructions in operator handbook.*
- ▲ *Ensure the tractor front, rear and sides are fitted with metal mesh or polycarbonate guards of suitable size and strength to protect the operator against thrown debris or parts.*
- ▲ *Ensure tractor guards are fitted correctly, are undamaged and kept properly maintained.*
- ▲ *Ensure that all machine guards are in position, are undamaged, and are kept maintained in accordance with the manufacturer's recommendations.*
- ▲ *Ensure that chains/blades and all fixings are genuine components supplied by the manufacturer specifically for the machine and are securely attached with no parts missing or damaged.*
- ▲ *Ensure chain wear does not exceed the following limits;*
  - For 10mm chains all links must have a minimum thickness of 8mm.*
  - For 13mm chains all links must have a minimum thickness of 10mm.*
- ▲ *Ensure all chains are the same length to maintain balance of the cutting unit.*
- ▲ *Ensure hydraulic pipes are carefully and correctly routed to avoid damage by chaffing, stretching or pinching and that they are held in place with the correct fittings.*
- ▲ *Always follow the manufacturer's instructions for attachment and removal of the machine from the tractor.*
- ▲ *Check that the machine fittings and couplings are in good condition.*
- ▲ *Ensure the tractor meets the minimum weight recommendations of the machine's manufacturer and that ballast is used as necessary.*
- ▲ *Always inspect the work area thoroughly before starting to note obstacles and remove wire, bottles, cans and other debris.*
- ▲ *Use clear suitably sized warning signs to alert others to the nature of the machine working within that area. Signs should be placed at both ends of the work site. (It is recommended that signs used are of a size and type specified by the Department of Transport and positioned in accordance with their, and the Local Highways Authority, guidelines).*
- ▲ *Ensure the operator is protected from noise. Ear defenders should be worn and tractor cab doors and windows must be kept closed. Machine controls should be routed through proprietary openings in the cab to enable all windows to be shut fully.*
- ▲ *Always work at a safe speed taking account of the conditions i.e.: terrain, highway proximity and obstacles around and above the machine. Extra special attention should be applied to Overhead Power Lines. Some of our machines are capable of reach in excess of 8 metres (26 feet) this means they have the potential to well exceed, by possibly 3 metres (9' 9"), the lowest legal minimum height of 5.2 metres from the ground for 11,000 and 33,000 volt power lines. It cannot be stressed enough the dangers that surround this capability, it is therefore vital that the operator is fully aware of the maximum height and reach of the machine, and that they are fully conversant with all aspects regarding the safe minimum distances that apply when working with machines in close proximity to Power Lines. (Further information on this subject can be obtained from the Health & Safety Executive or your Local Power Company).*

- ▲ *Always disengage the machine, kill the tractor engine, remove and pocket the key before dismounting for any reason.*
- ▲ *Always clear up all debris left at the work area, it may cause hazard to others.*
- ▲ *Always ensure when you remove your machine from the tractor that it is left in a safe and stable position using the stands and props provided and secured if necessary.*

#### **WHEN NOT TO USE THIS MACHINE:**

- ▲ *Never attempt to use this machine if you have not been trained to do so.*
- ▲ *Never use a machine until you have read and understood the operator handbook, are familiar with it, and practiced the controls.*
- ▲ *Never use a machine that is poorly maintained.*
- ▲ *Never use a machine if guards are missing or damaged.*
- ▲ *Never use a machine on which the hydraulic system shows signs of wear or damage.*
- ▲ *Never fit, or use, a machine on a tractor that does not meet the manufacturer's minimum specification level.*
- ▲ *Never use a machine fitted to a tractor that does not have suitable front, rear and side(s) cab guarding made of metal mesh or polycarbonate.*
- ▲ *Never use the machine if the tractor cab guarding is damaged, deteriorating or badly fitted.*
- ▲ *Never turn a machine cutting head to an angle that causes debris to be ejected towards the cab.*
- ▲ *Never start or continue to work a machine if people are nearby or approaching - Stop and wait until they are at a safe distance before continuing. WARNING: Some Cutting Heads may continue to 'freewheel' for up to 40 seconds after being stopped.*
- ▲ *Never attempt to use a machine on materials in excess of its capability.*
- ▲ *Never use a machine to perform a task it has not been designed to do.*
- ▲ *Never operate the tractor or machine controls from any position other than from the driving seat, especially whilst hitching or unhitching the machine.*
- ▲ *Never carry out maintenance of a machine or a tractor whilst the engine is running – the engine should be switched off, the key removed and pocketed.*
- ▲ *Never leave a machine unattended in a raised position – it should be lowered to the ground in a safe position on a level firm site.*
- ▲ *Never leave a tractor with the key in or the engine running.*
- ▲ *Never carry out maintenance on any part or component of a machine that is raised unless that part or component has been properly substantially braced or supported.*
- ▲ *Never attempt to detect a hydraulic leak with your hand – use a piece of cardboard.*
- ▲ *Never allow children near to, or play on, a tractor or machine under any circumstances.*

## ADDITIONAL SAFETY ADVICE

### Training

Operators need to be competent and fully capable of operating this machine in a safe and efficient way prior to attempting to use it in any public place. We advise therefore that the prospective operator make use of relevant training courses available such as those run by the Agricultural Training Board, Agricultural Colleges, Dealers and McConnel.

### Working in Public Places

When working in public places such as roadsides, consideration should be paid to others in the vicinity. Stop the machine immediately when pedestrians, cyclists and horse riders etc. pass. Restart only when they are at a distance that causes no risk to their safety.

### Warning Signs

It is advisable that any working area be covered by suitable warning signs and statutory in public places. Signs should be highly visible and well placed in order to give clear advanced warning of the hazard. Contact the Department of Transport or your Local Highways Authority to obtain detailed information on this subject. The latter should be contacted prior to working on the public highway advising them of the time and location of the intended work asking what is required by way of signs and procedure. – ‘*Non-authorised placement of road signs may create offences under the Highways Act*’.

### Suggested Warning Signs Required

**“Road works ahead”** warning sign with a supplementary **“Hedge cutting”** plate. **“For 1 mile”** or appropriate shorter distance may be added to the plate.

**“Road narrows”** warning sign with supplementary **“Single file traffic”** plate.

White on blue **“Keep right”** (\*) arrow sign on rear of machine.

\* Note – this applies to UK Market machines where traffic passes to the right of a machine working in the same direction as the traffic flow. The direction, use and colour of the arrow sign will depend on the country of use and the Local Highway Authorities regulations in the locality.

### Use of Warning Signs

- ▲ On two-way roads one set of signs is needed facing traffic in each direction.
- ▲ Work should be within 1 mile of the signs.
- ▲ Work only when visibility is good and at times of low risk e.g.: NOT during ‘rush-hour’.
- ▲ Vehicles should have an amber-flashing beacon.
- ▲ Ideally, vehicles should be conspicuously coloured.
- ▲ Debris should be removed from the road and path as soon as practicable, and at regular intervals, wearing high visibility clothing and before removing the hazard warning signs.
- ▲ Collect all road signs promptly when the job is completed.

---

Although the information given here covers a wide range of safety subjects, it is impossible to predict every eventuality that can occur under differing circumstances whilst operating this machine. No advice given here can replace ‘good common sense’ and ‘total awareness’ at all times, but will go a long way towards the safe use of your McConnel machine.

---



## VEHICLE / TRACTOR PREPARATION

We recommend vehicles are fitted with cabs using 'safety glass' windows and protective guarding when used with our machines.

**Fit Operator Guard (Part No. 7313324)** using the hooks provided. Shape the mesh to cover all vulnerable areas. The driver must be looking through mesh and/or polycarbonate glazing when viewing the flail head in any working position - unless the

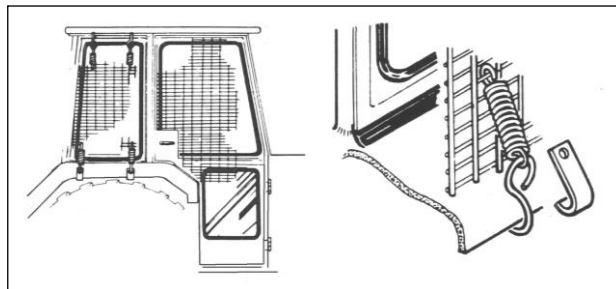

vehicle/ cab manufacturer can demonstrate that the penetration resistance is equivalent to, or higher than, that provided by mesh/polycarbonate glazing. If the tractor has a roll bar only, a frame must be made to carry both mesh and polycarbonate glazing. The operator should also use personal protective equipment to reduce the risk of serious injury such as; eye protection (*mesh visor to EN1731 or safety glasses to EN166*), hearing protection to EN352, safety helmet to EN297, gloves, filter mask and high visibility clothing.

**Vehicle Ballast:** It is imperative when attaching 'third-party' equipment to a vehicle that the maximum possible stability of the machine and vehicle combination is achieved – this can be accomplished by the utilisation of 'ballast' in order to counter-balance the additional equipment added.

**Front weights** may be required for rear mounted machines to place 15% of total outfit weight on the front axle for stable transport on the road and to reduce 'crabbing' due to the drag of the cutting unit when working on the ground.

**Rear weights** may be required to maintain a reasonable amount of rear axle load on the opposite wheel from the arms when in work; for normal off-ground work i.e. hedge cutting this should be 20% of rear axle weight or more for adequate control, and for ground work i.e. verge mowing with experienced operators, this can be reduced to 10%.

All factors must be addressed in order to match the type and nature of the equipment added to the circumstances under which it will be used – in the instance of Power Arm Hedgecutters it must be remembered that the machines centre of gravity during work will be constantly moving and will differ from that during transport mode, therefore balance becomes critical.

### Factors that effect stability:

- Centre of gravity of the tractor/machine combination.
- Geometric conditions, e.g. position of the cutting head and ballast.
- Weight, track width and wheelbase of the tractor.
- Acceleration, braking, turning and the relative position of the cutting head during these operations.
- Ground conditions, e.g. slope, grip, load capability of the soil/surface.
- Rigidity of implement mounting.

### Suggestions to increase stability:

- Increasing rear wheel track; a vehicle with a wider wheel track is more stable.
- Ballasting the wheel; it is preferable to use external weights but liquid can be added to around 75% of the tyre volume – water with anti-freeze or the heavier Calcium Chloride alternative can be used.
- Addition of weights – care should be taken in selecting the location of the weights to ensure they are added to a position that offers the greatest advantage.
- Front axle locking (check with tractor manufacturer).

**NOTE:** The advice above is offered as a guide for stability only and is not a guide to vehicle strength. It is recommended that you consult your vehicle manufacturer or local dealer to obtain specific advice on this subject, additionally advice should be sought from a tyre specialist with regard to tyre pressures and ratings suitable for the type and nature of the machine you intend to fit.

## OPERATION

---

The Rotary Head was designed for cutting scrub, brush and foliage of up to 100mm (4") in diameter or multiple branches that have a total cross section of equivalent size. The machines feature a hydraulically operated front hood (adjustable to 110°) which can be opened to accept larger material into the cutting unit.

Machines are available in a choice of either 1.2m or 1.5m working widths; 1.2m machines are fitted with a Ø13mm chain unit whilst 1.5m machines are fitted as standard with a Ø10mm chain unit with the option of either the heavier duty Ø13mm chain unit or double edged blade bar.

Ø10mm chain unit - recommended for Grass Work

Ø13mm chain unit - recommended for Scrub Work

### Cutting Direction

It is recommended that the direction of cutting should always be such that the blades or chains are cutting away from the operator at the point where the material first enters the machine; i.e. anti-clockwise for left hand mounted machines and clockwise for right hand mounted machines (when viewed from above).

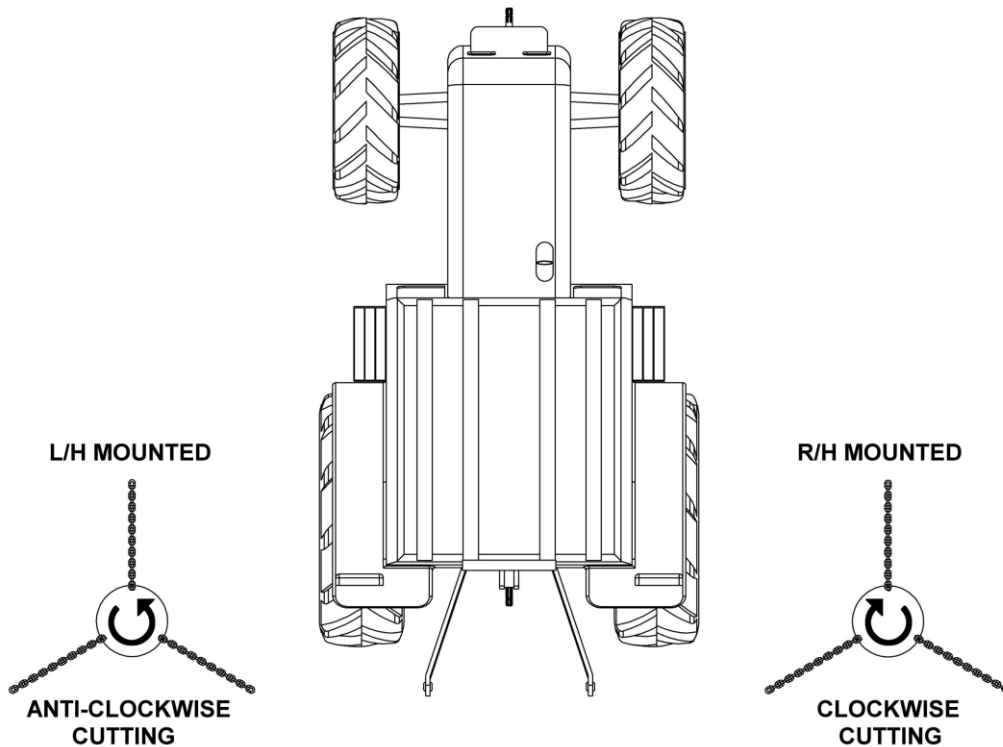

**WARNING!** When rotating parts are in motion, serious injury may occur if caution is not adopted or danger is not recognized. Never allow bystanders within 300 feet of the machine when in operation. Extreme care should be taken when operating near loose objects such as gravel, rocks and debris - these conditions should always be avoided.

The rotating parts in this machine have been designed and tested for rugged use. However, they could fail upon impact with heavy solid objects - such as steel guard rails, concrete abutments, etc., causing them to be thrown at a very high velocity. Never allow the cutter head to contact such objects; inspecting the cutting area for such objects and removing them prior to mowing will help eliminate these potential hazards.

Once on location, lower the mower deck slightly above the material to be cut, so the mower does not have to start under a load. With the tractor at an idle, engage mower. Bring tractor RPM up to the correct working speed (\*) and slowly lower deck to ground level. Maintaining even speed will ensure a clean cut.

(\*) NOTE: *Working speed will be dependant on the particular machine and model that this accessory is being operated on; refer to the operation manual for that machine for details.*

When mowing on the ground, the unit should always be 'carried' rather than 'dragged' on the skid skids. Dragging the unit will increase the side loads on the boom, decrease the horsepower available to the cutter head, and reduce the ability of the accumulator to carry part of the weight of the boom during mowing operations. It is recommended that it is carried in such a way that a proportion of its weight is supported by the boom of the operating machine, and a proportion carried by the side skids. When worked in this manner the skids, in association with the pivoted mounting, will allow it the freedom to follow the natural contours of the ground.

During mowing operation the correct operating speed should be maintained to prevent radical changes in mower spindle speeds, reducing risk of cutter assembly damage.

For cutting brush it is usually best to stop the tractor and swivel the boom and mower into foliage. The horizontal positioning action of the boom is designed to position the cutting head and provide a limited pressure relief when excessive pressure is applied to the boom. Never force the cutting head into heavy branches or stumps - damage to the unit may result.



**CAUTION!** When using the rotary cutting head for trimming trees and shrubs, let the mower 'saw' into them. Do not lower the mower head down directly onto a tree or stump. The mower blades are designed to cut with the end, any misuse can cause damage to the blade and risks placing the operator in a hazardous situation.



**CAUTION!** Powering the boom down, forcing mower deck onto ground may damage mower deck and it's attachment to the boom, creating a potentially hazardous situation.



**CAUTION! DO NOT** use excessive force when positioning cutting head into heavy branches or stumps. Damage to the unit may result. It is best to let the cutter head 'eat away' slowly at heavy cutting jobs.



**CAUTION!** If foliage falls on top of mower deck causing tractor to become unstable, move the boom 'Forward' and 'Out' to relieve tipping of the tractor. Lower mower deck to ground and shut down unit. After all motion stops, remove foliage from mower deck.

### **Machines fitted with Blade Units**

The mower will operate more efficiently in tougher conditions and with less power if the knives are kept sharp. If the mower begins to vibrate, stop the tractor, check for wire wrapped in the spindle or damaged knives. When replacing knives, replace all knives with new knives to ensure proper balance so the mower will not vibrate. Severe vibration will result, if knives with unequal wear are used.

Begin a pass at the top side of the trees and work down with each consecutive pass. When cutting trees and shrubs, use a lower speed to allow the knives time to cut as well as mulch the foliage.



**WARNING!** If bystanders approach within 300 feet while mower is in operation turn mower switch 'OFF' immediately. After shutdown, never leave the tractor or allow bystanders to approach within 300 FEET of the unit until all motion stops completely.

If cutter shaft jams and stops, turn mower switch to 'OFF', and swivel boom 'AFT'. Normally this action will clear the cutter head. If not, roll mower deck until adjacent to the secondary boom, and then lower boom to rest mower deck on ground. Shut off the tractor, set parking break, allow all motion to cease. At that point it is safe to leave the tractor and clear the cutter heads manually.

If wires, rope or chains should become entangled in the rotor stop immediately to prevent damage or dangerous situations; stop the rotor and tractor and remove the starting key. Put working gloves on and clear the rotor with the aid of pliers or shears. Do not attempt to disentangle by inverting the rotational direction of the rotor.

Begin each pass at the top side of the trees and work down with each consecutive pass. Use a low speed to allow the cutting blades time to mulch as well as cut the foliage. When the initial pass has been made, disengage the mower, and return boom to a safe travel position. Return to starting point and make next pass, etc..

### Hydraulic Front Hood

The machine is fitted as standard with a hydraulically operated front hood; the hood can be opened (up to 110°) to allow access to denser materials. For safety reasons the machine should be operated with the hood set at the lowest position that still allows the material to be cut to freely enter the head.

### Pivoted Mounting

The mounting bracket is pivoted to permit the unit deviation from the horizontal by  $\pm 7^\circ$  on 1.5m machines and  $+7^\circ$  on 1.2m machines; this is to allow the machine to follow the contours of the terrain on ground cutting work, thus providing a cleaner finish.

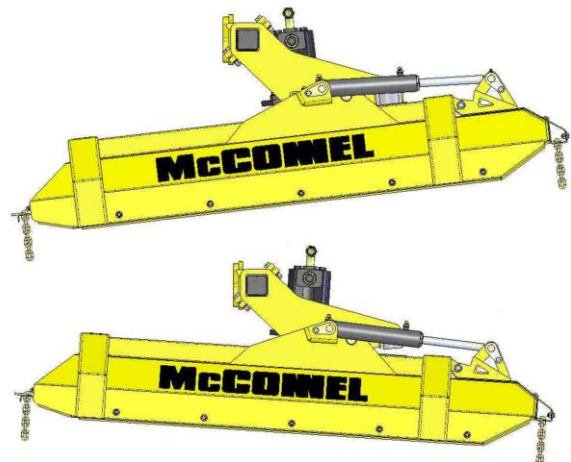

*1.5m model illustrated*

### Blade Nut Access Point

A removable cover is located on the deck of the machine to allow access to the blade bolt nut. If removed for service or maintenance work always ensure it is correctly replaced before using the machine.

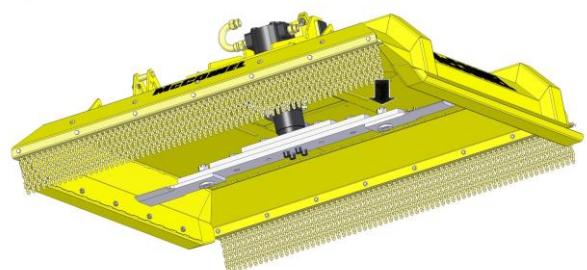
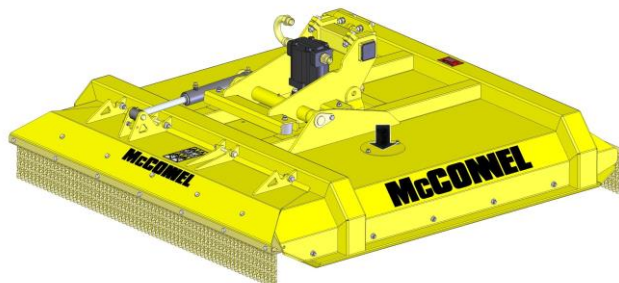

## Deck Stop

A Stop assembly is provided for placement on the connecting boom of the operating machine; it is multi-adjustable for use on 100mm square section or 100/110mm tapered section booms.

Its function is primarily to stop the deck coming into contact with the machines arm components when the head is fully angled, but also acts as a support for the unit during transportation.

The stop should be assembled to the required configuration to fit the specific boom and positioned on the boom at a height where the rubber buffers contact an outer point on the top of the deck when the unit is fully angled in either direction.

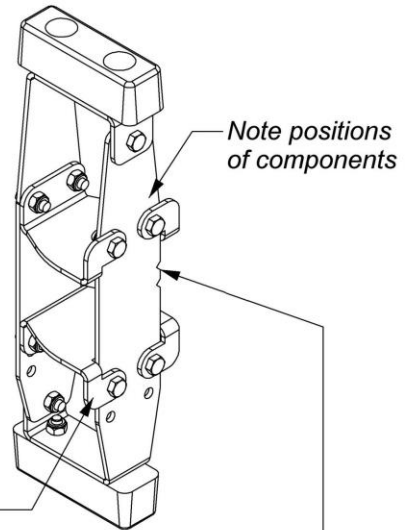
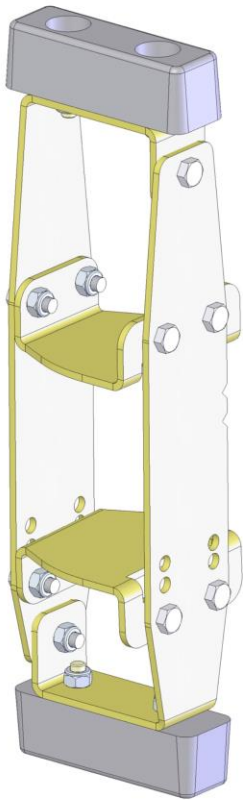

*Note positions of components*

ASSEMBLED FOR:  
100MM SQUARE ARM SECTION

### ASSEMBLY NOTE:

*The notches should be nearest to the top of the dipper arm and facing towards the head pivot tube.*

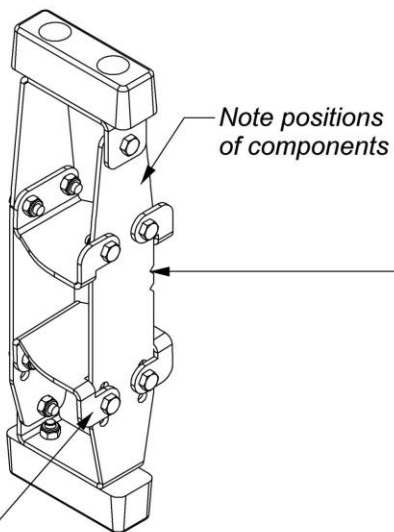

*Note positions of components*

ASSEMBLED FOR:  
100MM WIDE TAPERED ARM SECTION

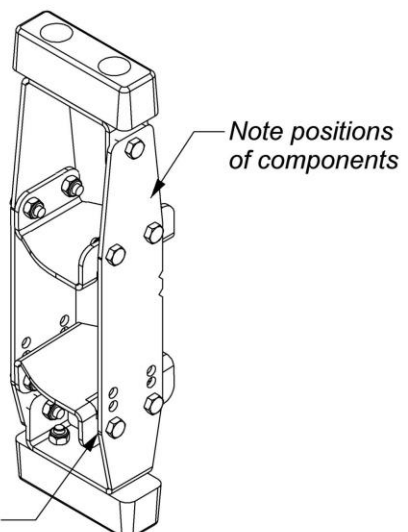

*Note positions of components*

*Note positions of components*

ASSEMBLED FOR:  
110MM WIDE TAPERED ARM SECTION

## TRANSPORTATION

---

### Transport Position

When transporting between job sites, or between cutting passes, the following procedure should be followed; shut off the power to the cutting head and allow all motion to come to a complete stop. Raise the boom to its highest position taking care to avoid all overhead obstructions such as power cables, trees etc. Rotate the deck to a position where it contacts the stop buffer before then folding the arms of the machine into a position where it is as compact as possible. Fit and secure any transport locks and close the lift ram tap if applicable.

Check before transporting that the unit has ample clearance from the tractor tyres and other tractor or machine components. The unit is now in position for transportation.

### Transport Speed

Transport speeds should be kept to a minimum on uneven terrain, and in all conditions avoid driving at a speed which causes exaggerated bouncing as this will put unnecessary strain on the tractors top hitch position

## MAINTENANCE

---

Maintenance duties on the machine have been kept to a minimum, the grease points indicated below should be lubricated on a daily basis prior to work and the level of oil in the bearing housing checked. Top up to plug level (if required) using EP90 gearbox oil.

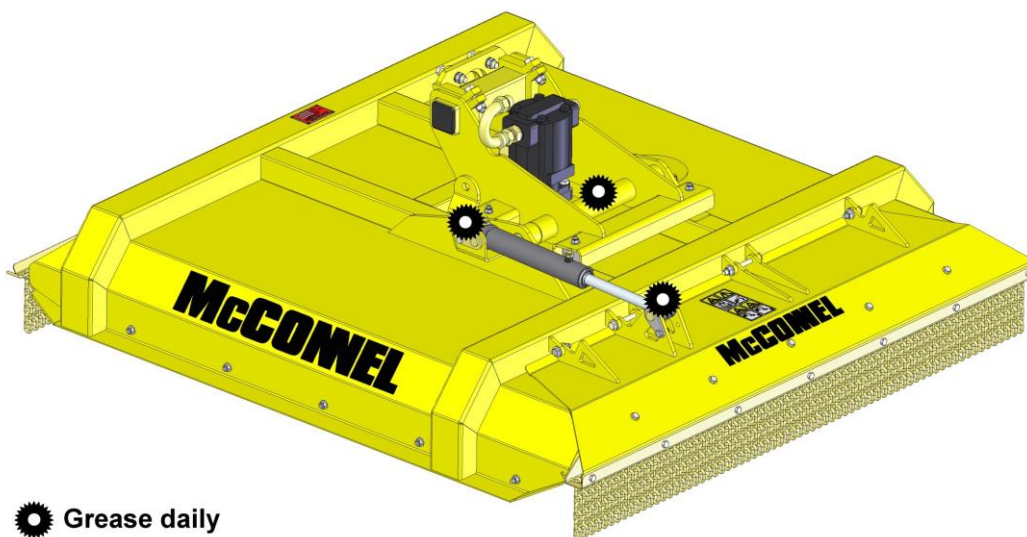

After work and always prior to storage the machine should be cleaned to remove dirt and debris. Grease points indicated above prior to storage.





## McConnel Generic Parts Manual

*Generic parts manuals should be used as a general guide to the components used on the machine; to ensure accurate parts information for a specific machine please refer to the 'Interactive Parts Database' on our website which identifies the exact components used on the machine when it was manufactured based on the machine's unique serial number.*

*Direct access can be gained using the web address or QR code below.*  
<http://www.mcconnel.com/support/product-support/interactive-parts-database/>



*Design improvements may have altered some of the parts listed in this manual; latest parts will always be supplied if they are interchangeable with earlier ones.*



# 1.2M ROTARY HEAD CASING ASSEMBLY

**McCONEL**

Module(s): 1039733

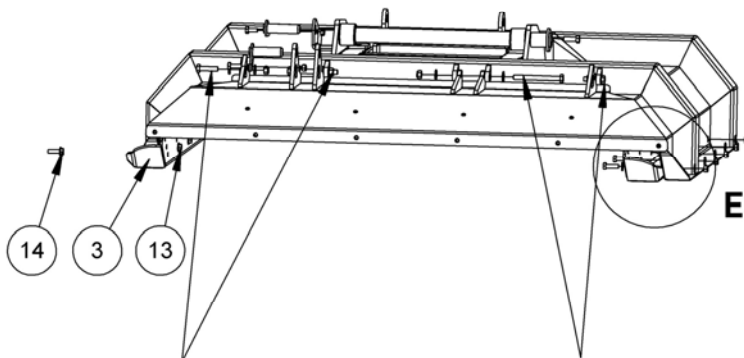
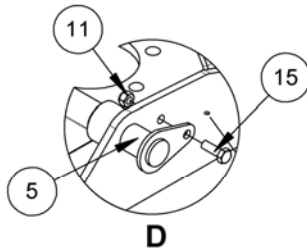
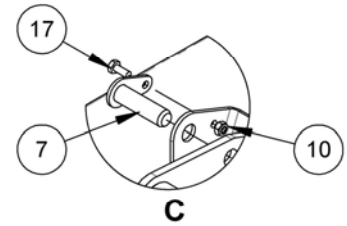
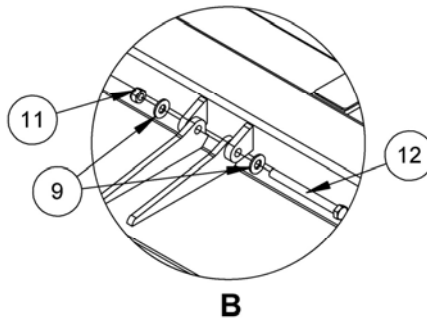
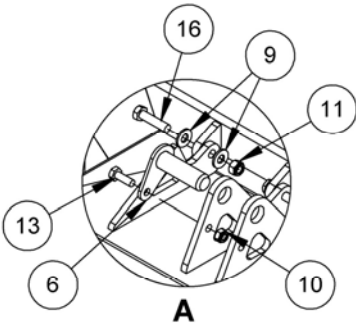
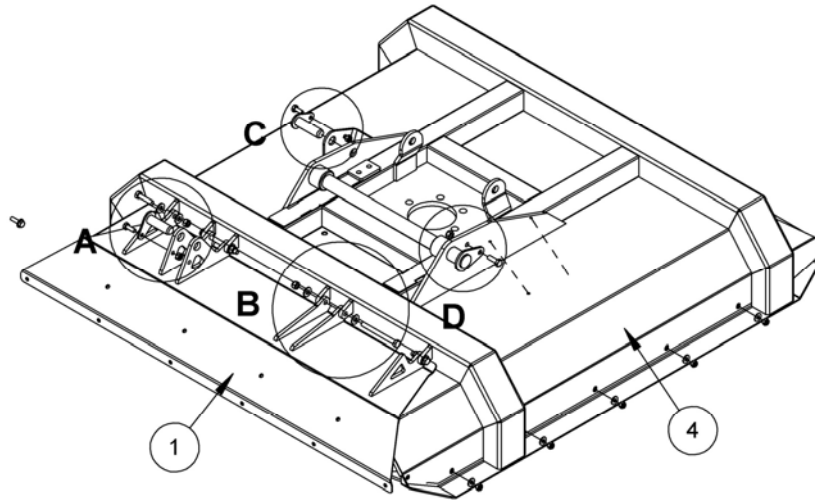

*NOTE: Tighten hood fixings to a point that still allows for free movement of the hood.*

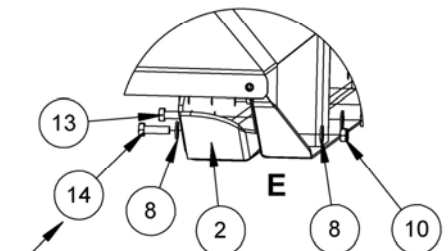

*NOTE: Longer setscrew is for guard plate from flap module.*

**1.2M ROTARY HEAD CASING ASSEMBLY****McCONNEL**

Module(s): 1039733

<b>REF.</b>	<b>QTY.</b>	<b>PART No.</b>	<b>DESCRIPTION</b>
		<b>1039733</b>	<b>1.2M ROTARY HEAD CASING</b>
1	1	22286.05	FRONT HOOD
2	1	22408.07	LH SKID
3	1	22408.08	RH SKID
4	1	22415.04	ROTARY HEAD CASING
5	1	22421.01	PIVOT PIN
6	1	41691.06	PIN
7	1	22168.02	PIN
8	20	9100105	FLAT WASHER
9	8	9100106	FLAT WASHER
10	12	9163005	NYLOC NUT
11	5	9163006	NYLOC NUT
12	2	9213266	BOLT
13	9	9313065	SETSCREW
14	2	9313075	SETSCREW
15	1	9313076	SETSCREW
16	2	9313106	SETSCREW
17	1	9313055	SETSCREW

# 1.5M ROTARY HEAD CASING ASSEMBLY

**McCONEL**

Module(s): 1039730

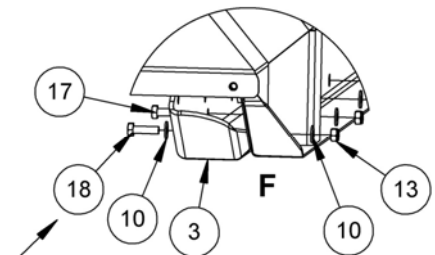
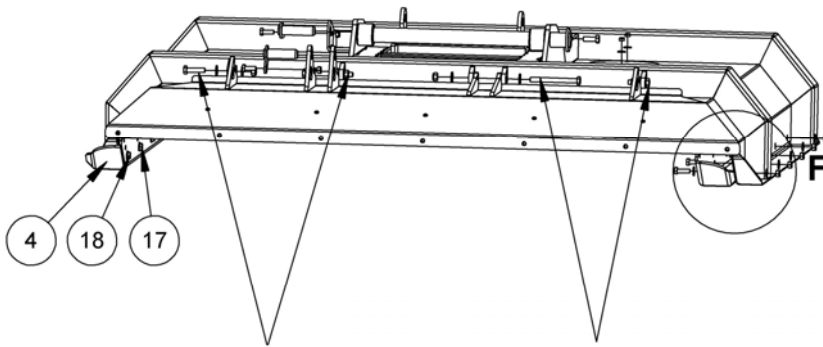
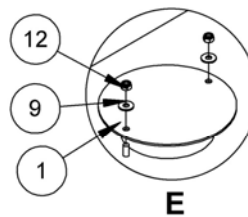
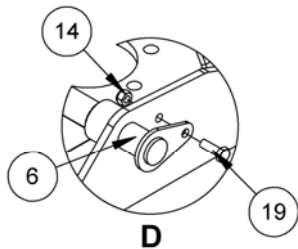
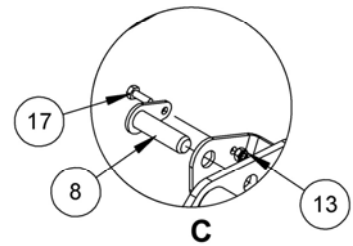
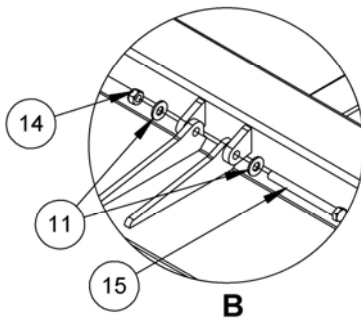
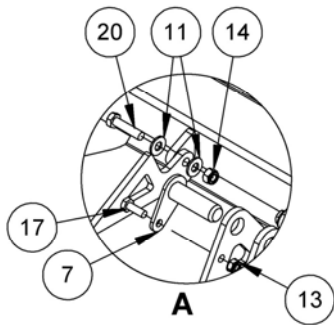
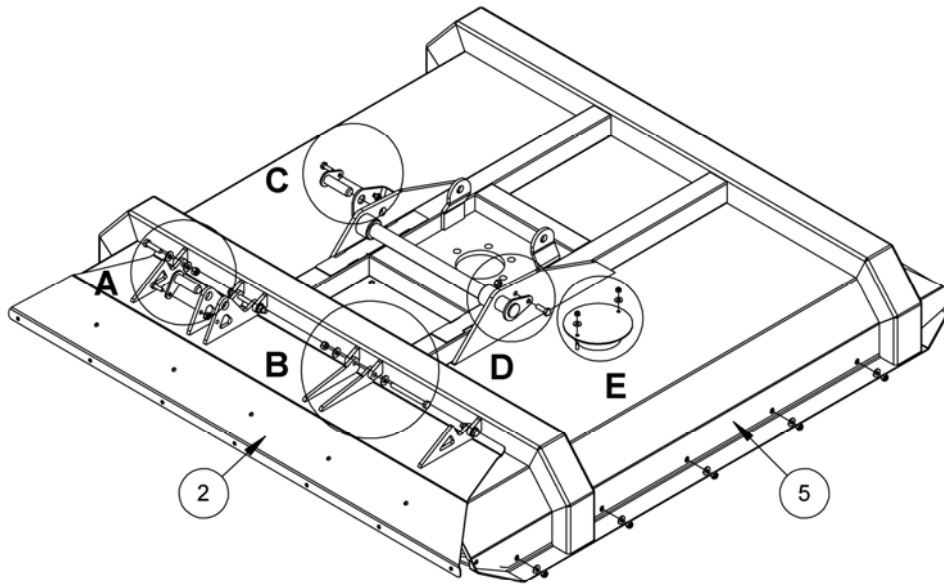

*NOTE: Tighten hood fixings to a point that still allows for free movement of the hood.*

*NOTE: Longer setscrew is for guard plate from flap module.*

## 1.5M ROTARY HEAD CASING ASSEMBLY

**McCONNEL**

Module(s): 1039730

REF.	QTY.	PART No.	DESCRIPTION
		<b>1039730</b>	<b>1.5M ROTARY HEAD CASING</b>
1	1	21833.01	COVER
2	1	22286.04	FRONT HOOD
3	1	22408.05	LH SKID
4	1	22408.06	RH SKID
5	1	22415.03	ROTARY HEAD CASING
6	1	22421.01	PIVOT PIN
7	1	41691.06	PIN
8	1	22168.02	PIN
9	2	9100104	FLAT WASHER
10	20	9100105	FLAT WASHER
11	8	9100106	FLAT WASHER
12	2	9163004	NYLOC NUT
13	12	9163005	NYLOC NUT
14	5	9163006	NYLOC NUT
15	2	9213266	BOLT
16	1	9313055	SETSCREW
17	11	9313065	SETSCREW
18	2	9313075	SETSCREW
19	1	9313076	SETSCREW
20	2	9313106	SETSCREW

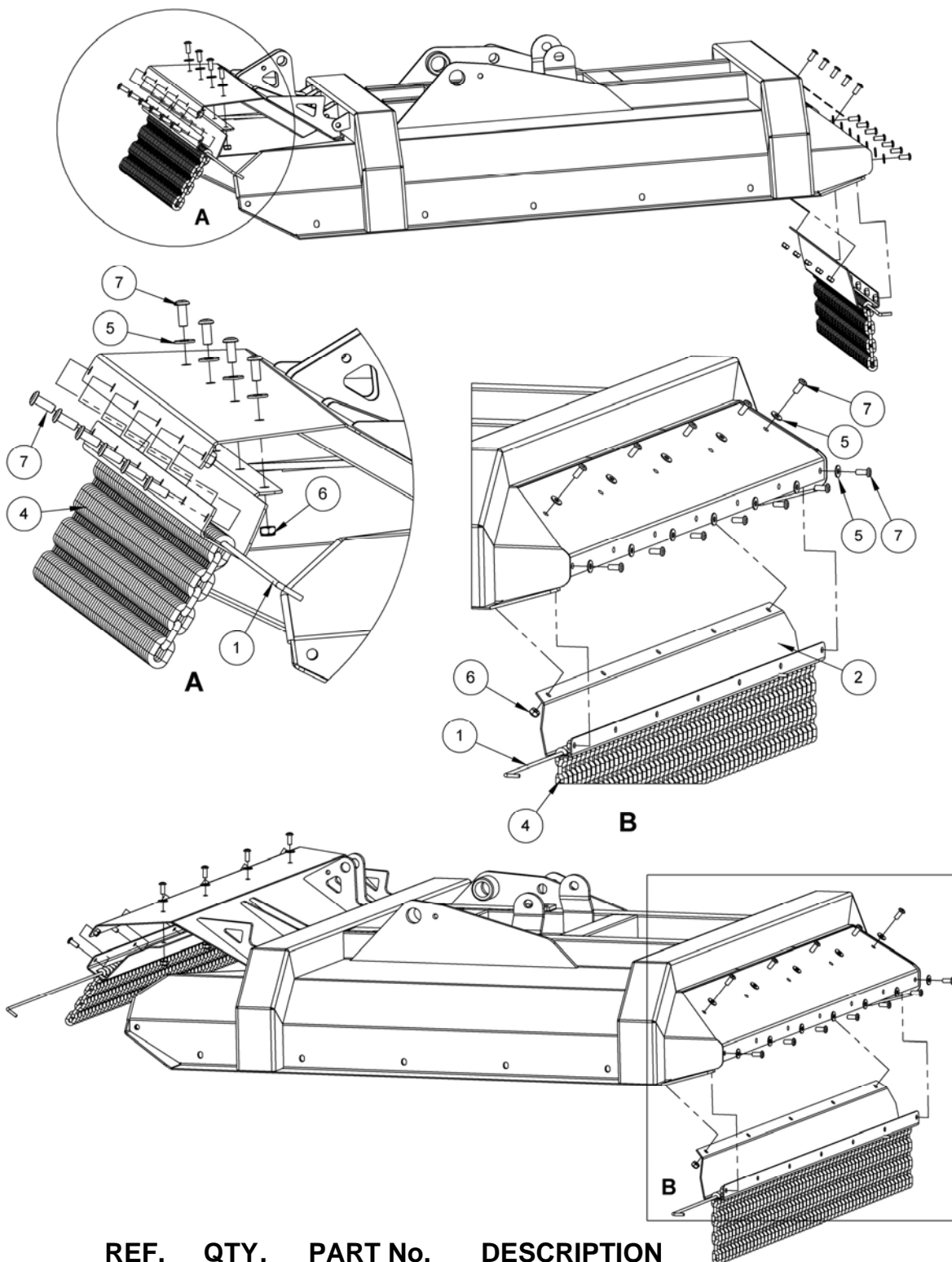

REF.	QTY.	PART No.	DESCRIPTION
		<b>1039734</b>	<b>CHAIN GUARD ASSEMBLIES</b>
1	2	22148.15	CHAIN RETAINING BAR
2	1	22321.06	REAR CHAIN GUARD MOUNTING
3	1	22321.07	FRONT CHAIN GUARD MOUNTING
4	112	46943.21	CHAIN ASSEMBLY (7 LINKS)
5	16	9100105	FLAT WASHER
6	9	9163005	NYLOC NUT
7	22	9300154	SOCKET SCREW

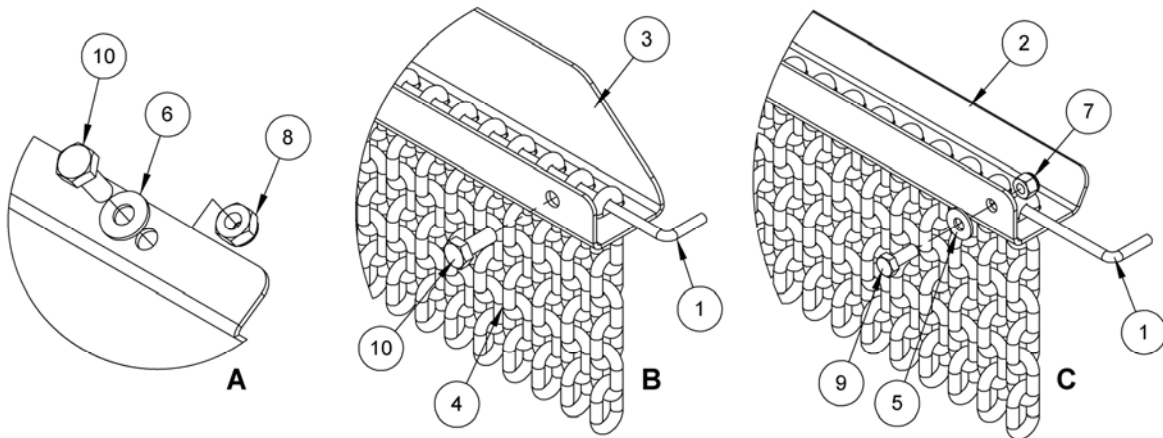
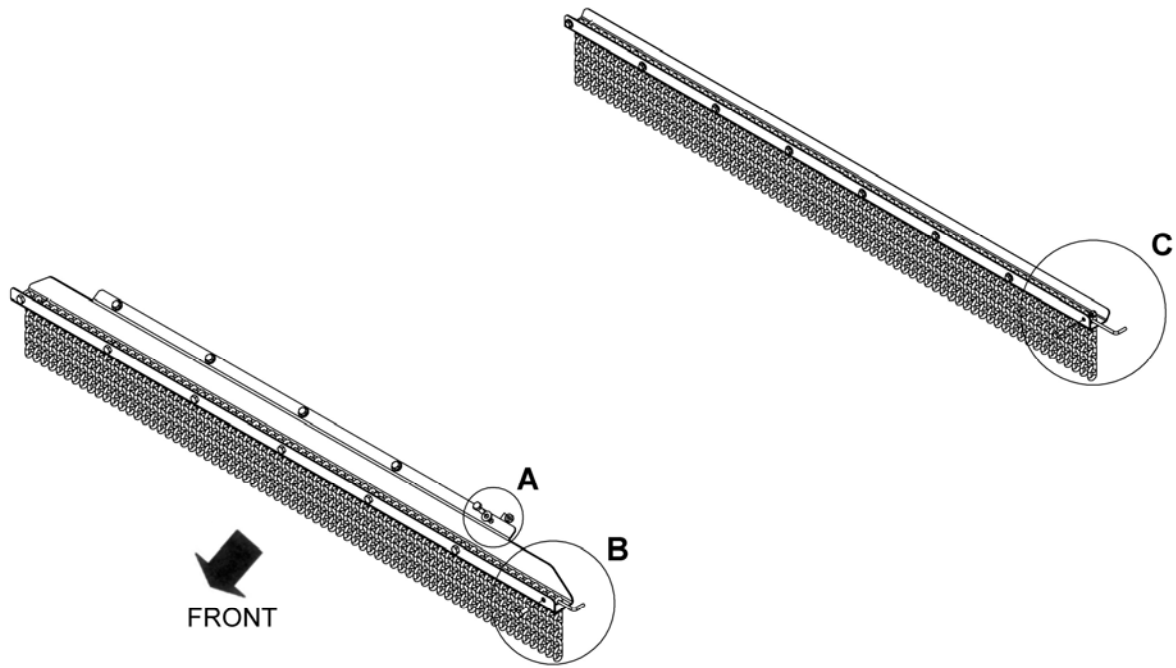

REF.	QTY.	PART No.	DESCRIPTION
		<b>1039718</b>	<b>CHAIN GUARD ASSEMBLIES</b>
1	2	22148.10	CHAIN RETAINING BAR
2	1	22321.01	REAR CHAIN GUARD MOUNTING
3	1	22321.03	FRONT CHAIN GUARD MOUNTING
4	136	46943.21	CHAIN ASSEMBLY (7 LINKS)
5	8	9100104	FLAT WASHER
6	5	9100105	FLAT WASHER
7	8	9163004	NYLOC NUT
8	5	9163005	NYLOC NUT
9	8	9313044	SETSCREW
10	12	9313055	SETSCREW

# PIVOTING MOUNTING BRACKET ASSEMBLY

**McCONEL**

Module(s): 1039715

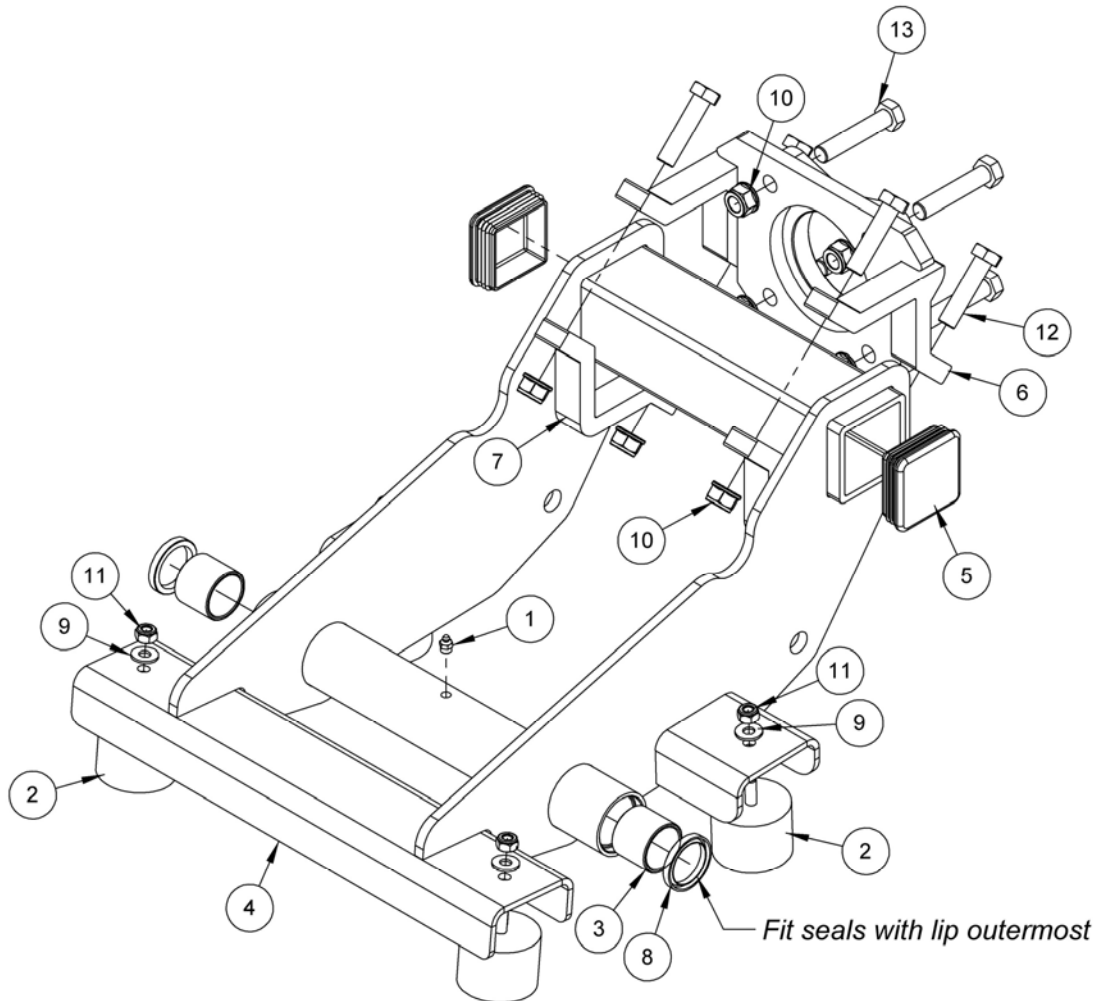

REF.	QTY.	PART No.	DESCRIPTION
		<b>1039715</b>	<b>PIVOTING MOUNTING BRACKET</b>
1	1	0901121	GREASE NIPPLE
2	4	1337114	RUBBER BUFFER
3	2	21385.01	BUSH
4	1	22386.07	PIVOTING MOUNTING
5	2	41580.01	PLASTIC PLUG
6	1	7198330	CLAMP
7	2	7198332	CLAMP
8	2	8629219	ROTARY SHAFT SEAL
9	4	9100105	FLAT WASHER
10	8	9100024	SELF-LOCKING FLANGE NUT
11	4	9163005	NYLOC NUT
12	4	9200024	BOLT
13	4	9210167	BOLT

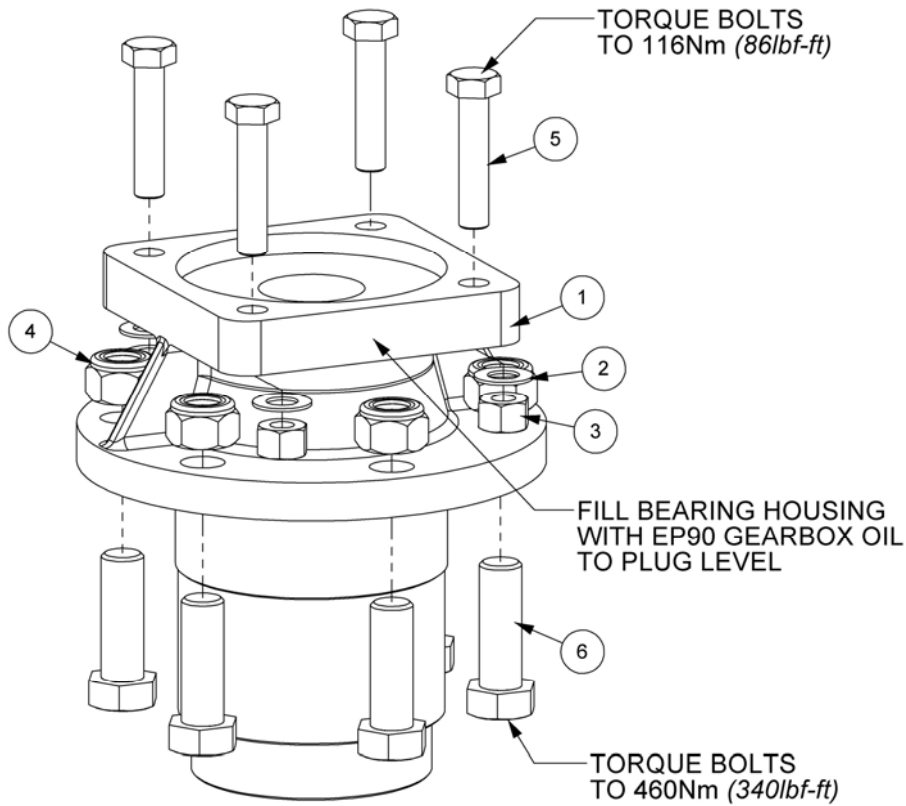

REF.	QTY.	PART No.	DESCRIPTION
		<b>1039729</b>	<b>BEARING UNIT</b>
1	1	02960553B	SPINDLE & HOUSING ASSEMBLY
2	4	9100020	FLAT WASHER
3	4	9100022	SELF-LOCKING NUT
4	6	9163008	NYLOC NUT
5	4	9200056	BOLT
6	6	9213128	BOLT



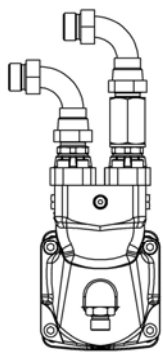

LH BUILD

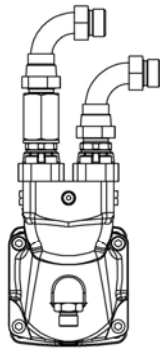

RH BUILD

*RH Build illustrated*

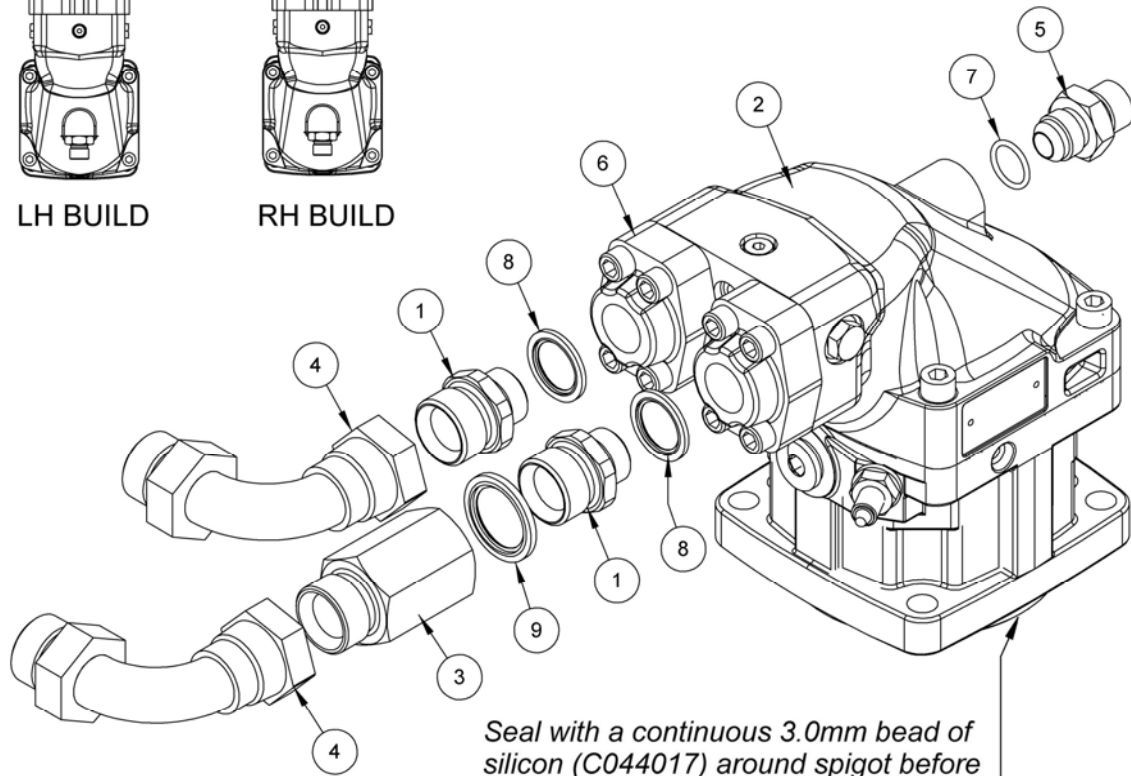

*Seal with a continuous 3.0mm bead of silicon (C044017) around spigot before fitting to bearing housing*

REF.	QTY.	PART No.	DESCRIPTION
		<b>1039741</b>	<b>PISTON MOTOR MODULE</b>
1	2	8002086	ADAPTOR
2	1	8301326	PISTON MOTOR (60cc)
3	1	8581211	EXTENSION ADAPTOR
4	2	8581264	ADAPTOR - SWEPT 90°
5	1	8581379	ADAPTER
6	2	8581597	FLANGE
7	1	8600910	O RING
8	2	8650106	BONDED SEAL
9	1	8650108	BONDED SEAL

Module(s): 1039746

**CONNECTIONS FOR LEFT HAND MACHINE**

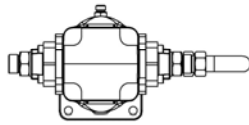

**CONNECTIONS FOR RIGHT HAND MACHINE**

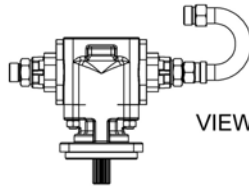
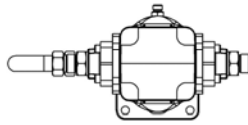

VIEWED FROM REAR OF HEAD

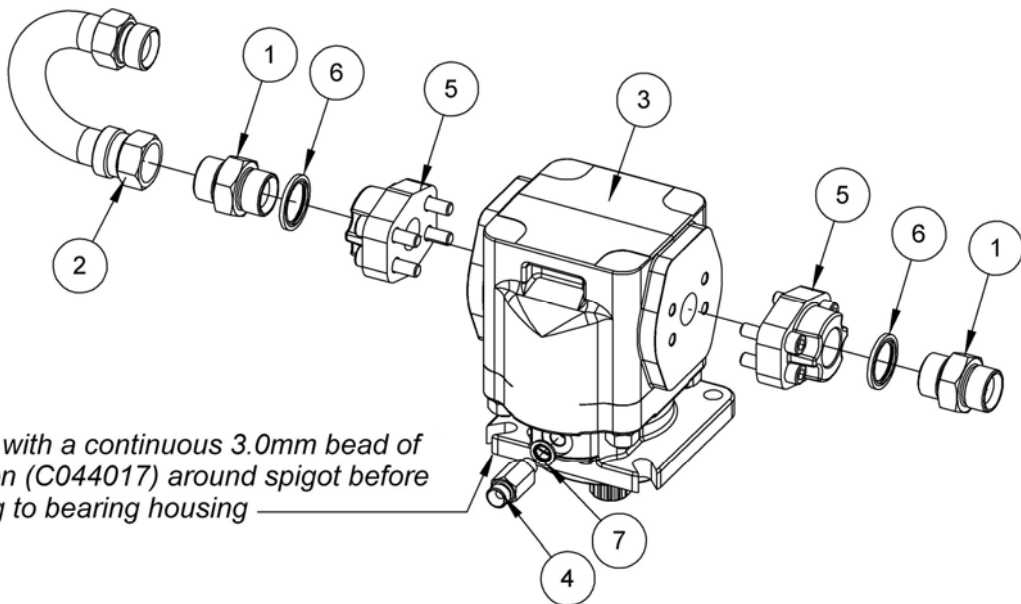
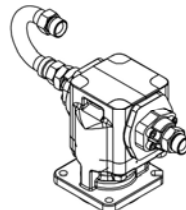
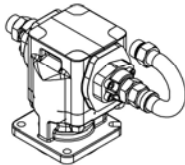
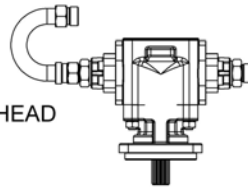

Seal with a continuous 3.0mm bead of silicon (C044017) around spigot before fitting to bearing housing

REF.	QTY.	PART No.	DESCRIPTION
		<b>1039746</b>	<b>MOTOR MODULE (125LPM)</b>
1	2	05.434.01	ADAPTOR
2	1	46043.01	RIGID PIPE
3	1	8301328	MOTOR (70cc)
4	1	8581146	ADAPTOR EXTENSION
5	2	8581566	FLANGE
6	2	8650108	BONDED SEAL
7	1	8650102	BONDED SEAL

# GEAR MOTOR (125L/min) – 1.5M Models

# McCONNEL

Module(s): 1039724

## CONNECTIONS FOR LEFT HAND MACHINE

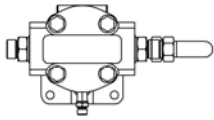

## CONNECTIONS FOR RIGHT HAND MACHINE

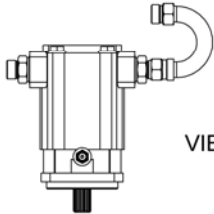
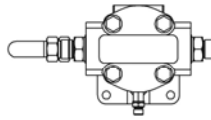

VIEWED FROM REAR OF HEAD

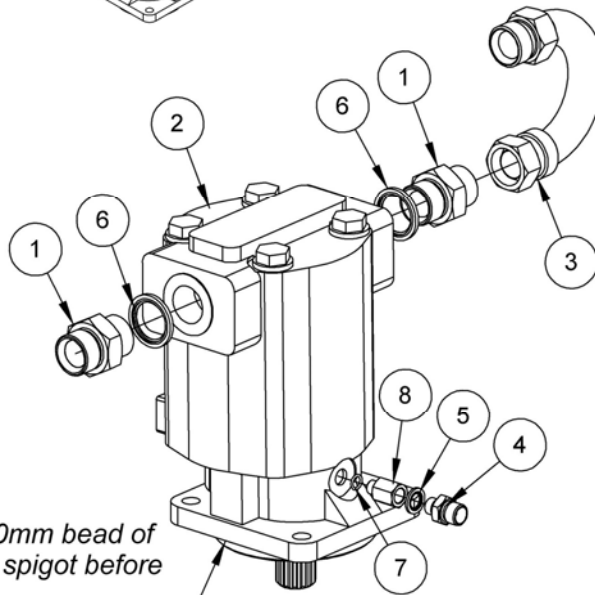
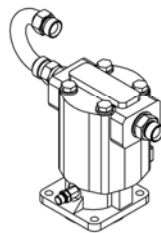
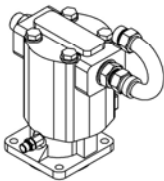
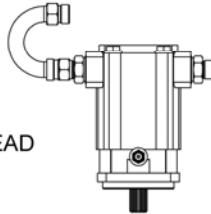

Seal with a continuous 3.0mm bead of silicon (C044017) around spigot before fitting to bearing housing

REF.	QTY.	PART No.	DESCRIPTION
		<b>1039724</b>	<b>GEAR MOTOR (125L/min)</b>
1	2	05.434.01	ADAPTOR (BSP)
2	1	43506.01	HYDRAULIC MOTOR
3	1	46043.01	RIGID PIPE
4	1	8581115	ADAPTOR
5	1	8650102	BONDED SEAL
6	2	8650108	BONDED SEAL
7	1	8600904	O RING
8	1	8581458	ADAPTOR (UNF)

# 1.2M CUTTING CHAIN ASSEMBLY (HEAVY DUTY)

**McCONNEL**

Module(s): 1039737

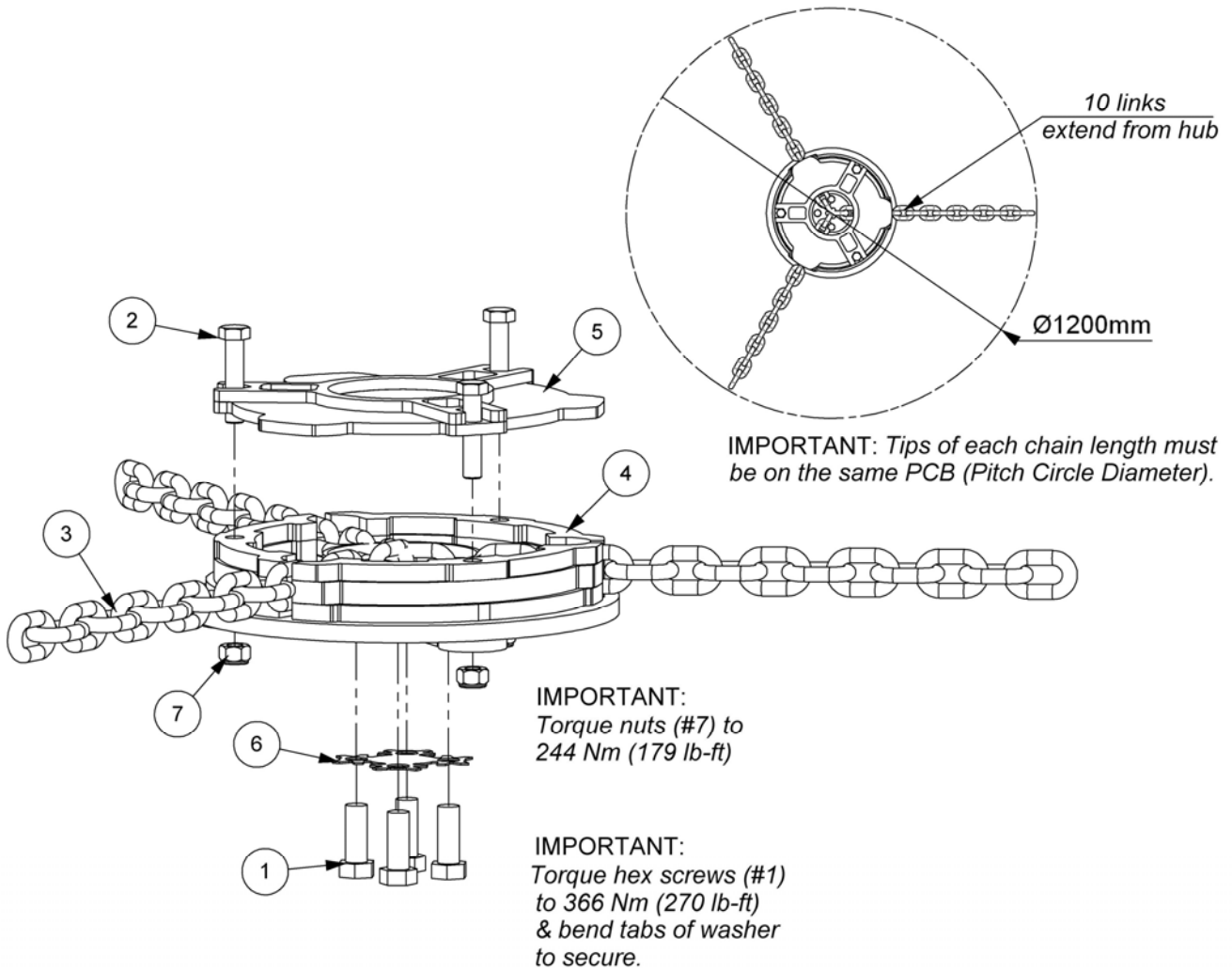

REF.	QTY.	PART No.	DESCRIPTION
		<b>1039737</b>	<b>1.2M CUTTING CHAIN ASSEMBLY</b>
1	4	0312167	HEX SCREW
2	3	12.714.75	BOLT
3	1	22315.03	CHAINS ø13mm (SET OF 3)
4	1	22323.05	CHAIN MOUNTING HUB
5	1	22327.02	CHAIN CLAMP PLATE
6	1	22630.01	SPECIAL TAB WASHER
7	3	T7942	NYLOC NUT

# 1.5M CUTTING CHAIN ASSEMBLY (STD. DUTY)

**McCONEL**

Module(s): 1039728

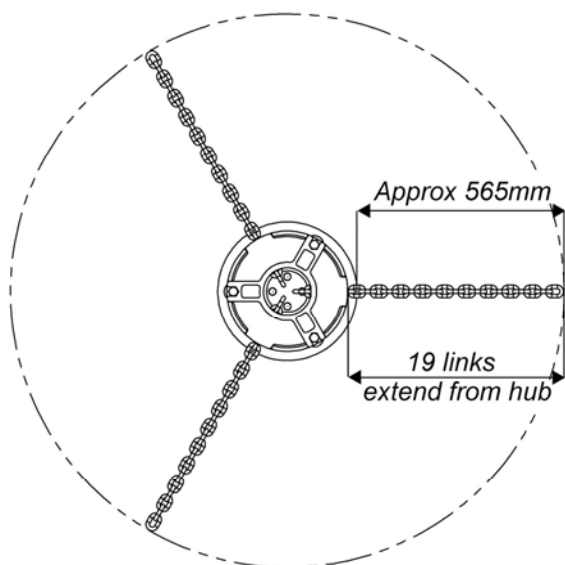

**IMPORTANT:** *Tips of each chain length must be on the same PCB (Pitch Circle Diameter).*

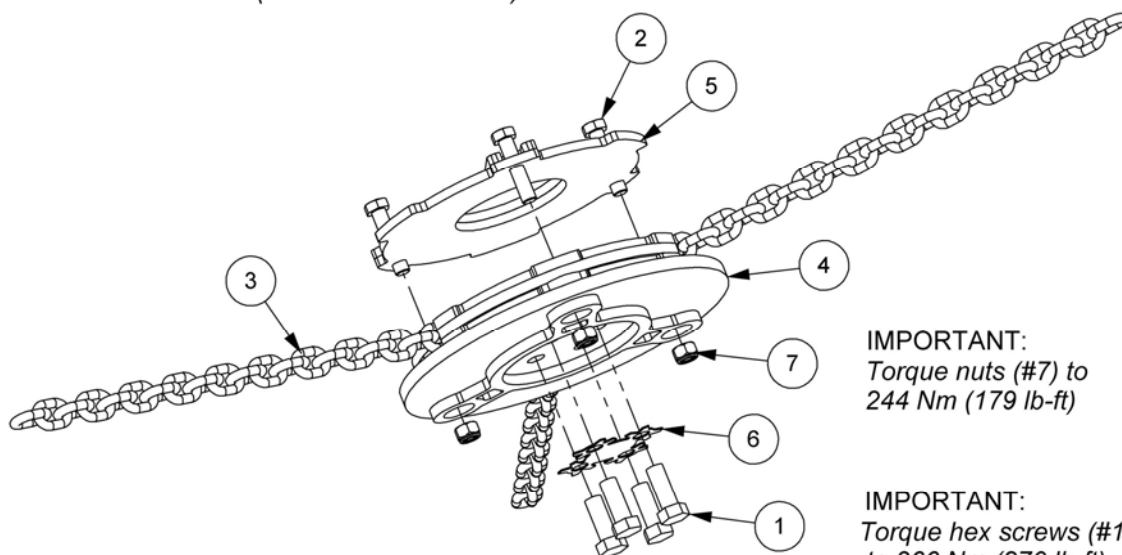

**IMPORTANT:**  
Torque nuts (#7) to  
244 Nm (179 lb-ft)

**IMPORTANT:**  
Torque hex screws (#1)  
to 366 Nm (270 lb-ft)  
& bend tabs of washer  
to secure.

REF.	QTY.	PART No.	DESCRIPTION
		<b>1039728</b>	<b>1.5M CUTTING CHAIN ASSEMBLY</b>
1	4	0312167	HEX SCREW
2	3	12.714.75	BOLT
3	1	22315.01	CHAINS Ø10mm (SET OF 3)
4	1	22323.04	CHAIN MOUNTING HUB
5	1	22327.02	CHAIN CLAMP PLATE
6	1	22630.01	SPECIAL TAB WASHER
7	3	T7942	NYLOC NUT

# 1.5M CUTTING CHAIN ASSEMBLY (HEAVY DUTY)

**McCONNEL**

Module(s): 1039708

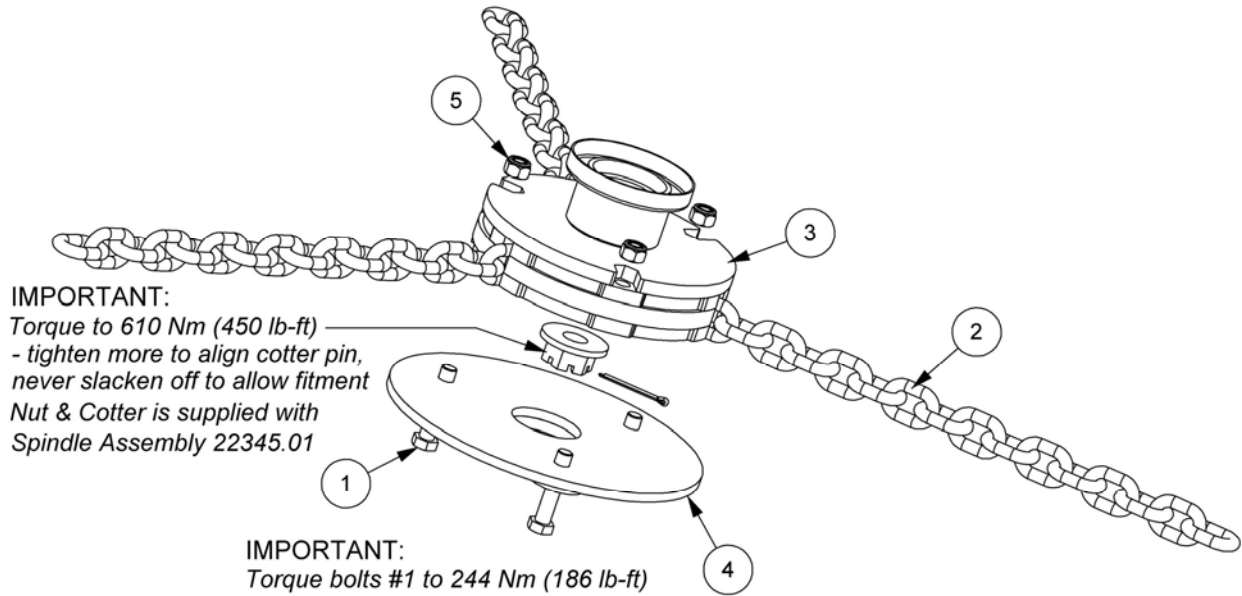

REF.	QTY.	PART No.	DESCRIPTION
		<b>1039708</b>	<b>1.5M CHAIN CUTTING ASSEMBLY</b>
1	3	9210167	BOLT
2	1	22315.02	CHAINS Ø13mm (SET OF 3)
3	1	22323.03	CHAIN MOUNTING HUB
4	1	22327.01	CHAIN CLAMP
5	3	T7942	NYLOC NUT

Module(s): 1039756

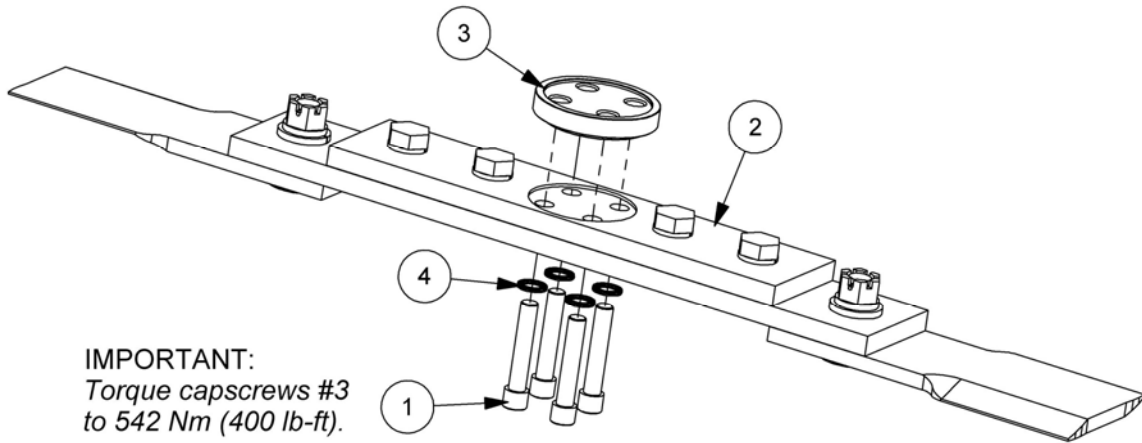

**IMPORTANT:**  
Torque capscrews #3  
to 542 Nm (400 lb-ft).

REF.	QTY.	PART No.	DESCRIPTION
		<b>1039756</b>	<b>BLADE BAR - 1.2M Models</b>
1	4	02973438	CAPSCREW
2	1	02971919	BLADE BAR ASSEMBLY
3	1	23165.01	BLADE SPACER
4	4	B001020	NORDLOCK WASHER

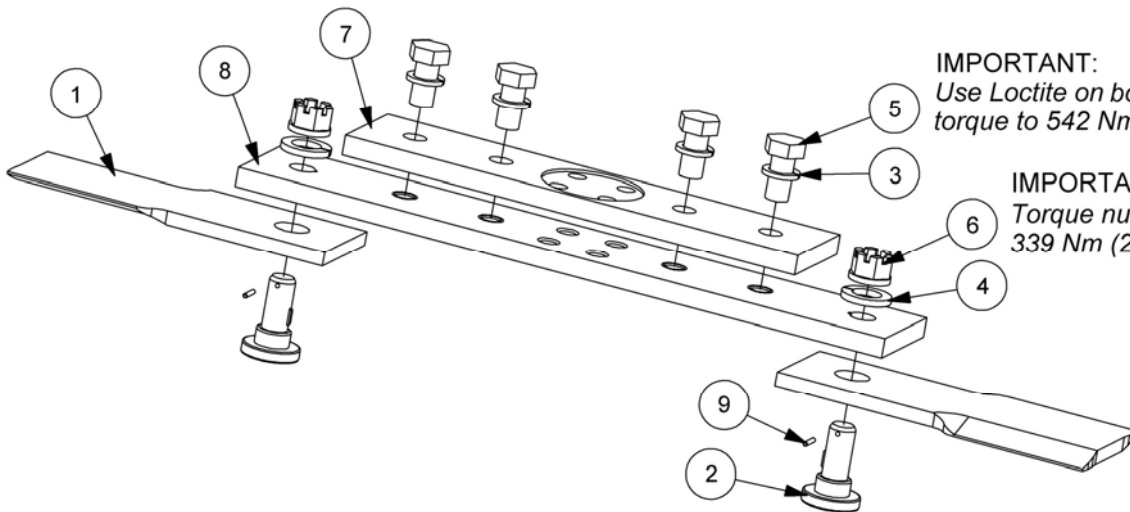

**IMPORTANT:**  
Use Loctite on bolts #7 and  
torque to 542 Nm (400 lb-ft).

**IMPORTANT:**  
Torque nuts #8 to  
339 Nm (250 lb-ft).

REF.	QTY.	PART No.	DESCRIPTION
		<b>02971919</b>	<b>BLADE BAR ASSEMBLY</b>
1	1	02761500	BLADE SET
2	2	02782900	BLADE BOLT
3	4	02032200	SPRING WASHER
4	2	02957089	SPRING WASHER
5	4	02782200	HEX SCREW
6	2	00020900	FLANGE NUT (SLOTTED)
7	1	02972126	BLADE BAR LEAF
8	1	02971917	BLADE BAR LEAF
9	2	00023200	ROLL PIN

# BLADE BAR ASSEMBLY – 1.5m Heads

**McCONNEL**

Module(s): 02782300

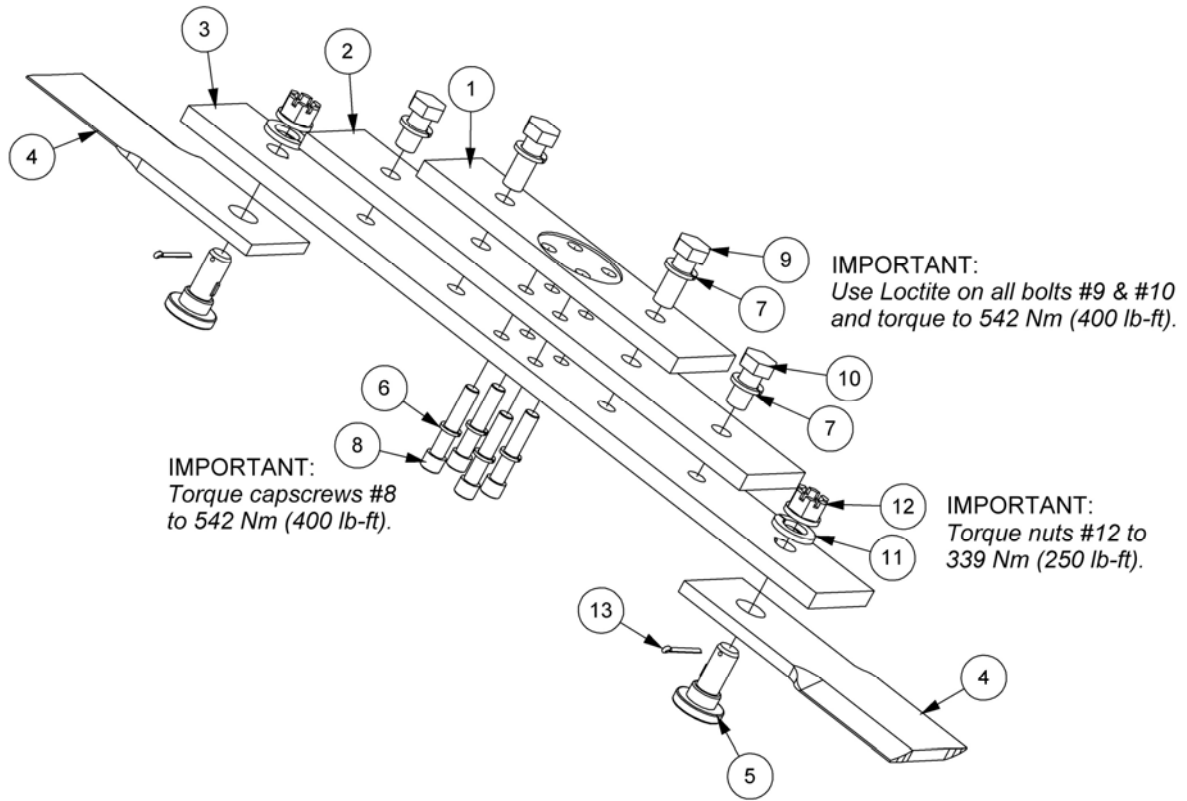

REF.	QTY.	PART No.	DESCRIPTION
		<b>02782300</b>	<b>BLADE BAR - 1.5M Builds</b>
1	1	02781600	BLADE BAR LEAF (TOP)
2	1	02781700	BLADE BAR LEAF (CENTRE)
3	1	02781800	BLADE BAR LEAF (BOTTOM)
4	1	02761500	BLADE SET
5	2	02782900	BLADE BOLT
6	4	00003901	SPRING WASHER
7	4	02032200	SPRING WASHER
8	4	02708700	SOCKET CAPSCREW
9	2	02782100	HEX SCREW
10	2	02782200	HEX SCREW
11	2	02957089	SPRING WASHER
12	2	00020900	FLANGE NUT (SLOTTED)
13	2	00023200	ROLL PIN



FIT 1" BSP HOSES THROUGH HOSE SLEEVING BEFORE CONNECTING TO JUNCTION BRACKET.

FIT BLANKING PLUGS TO HOSES

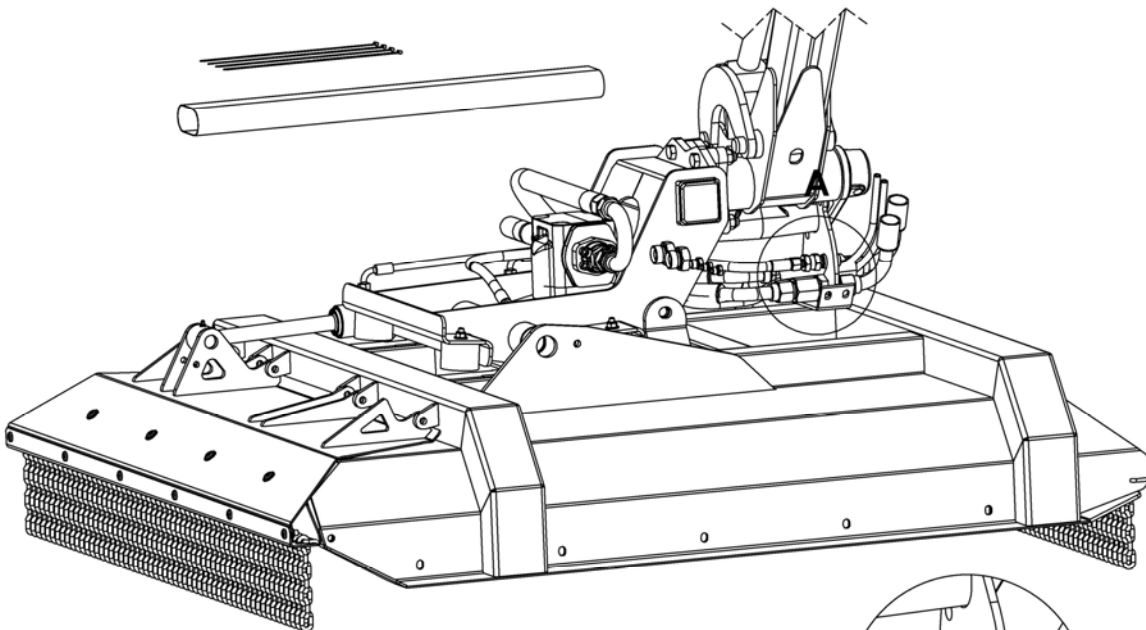
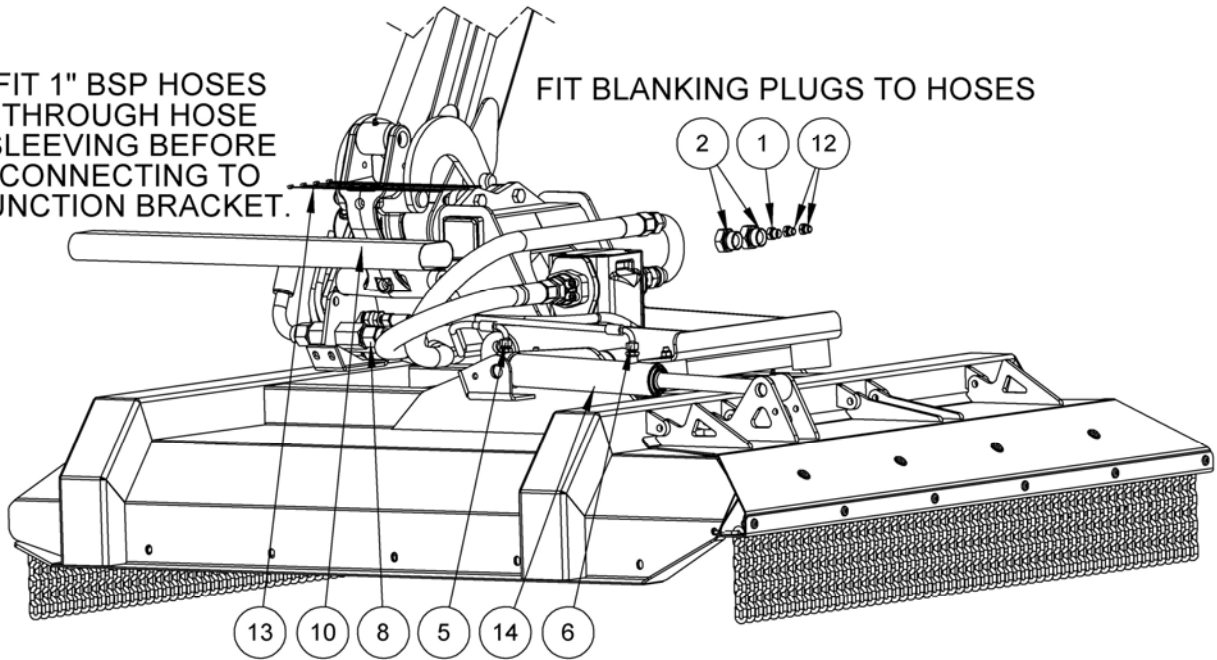

1/4" BSP HOSES RUN IN SLEEVING AS THEY PASS THROUGH THE JUNCTION BRACKET

Module(s): 1039745

REF.	QTY.	PART No.	DESCRIPTION
		<b>1039745</b>	<b>HYDRAULIC INSTALLATION (GEAR)</b>
1	1	05.433.01	BLANKING PLUG C/W CONE
2	2	05.433.03	MALE PLUG WITH CONE
3	4	10.001.20	HOSE - 1/4" BSP FS/FS x 1000mm
4	2	10.001.73	HOSE - 1/4" BSP FS/FS x 6300mm
5	1	10.002.37	HOSE - 1/4" BSP FS/F90 x 2700mm
6	1	10.002.40	HOSE - 1/4" BSP FS/F90 x 3000mm
7	1	10.004.18	HOSE - 3/8" BSP FS/F90 x 900mm
8	1	10.025.15	HOSE - 1" BSP FS/F135 x 750mm
9	1	10.025.22	HOSE - 1" BSP FS/F135 x 1200mm
10	1	22590.16	HOSE SLEEVING - 800mm
11	1	22591.03	HOSE SLEEVING - 150mm
12	2	520378	ADAPTOR PLUG
13	4	7196045	HOSE TIE
14	1	7560356	COMPENSATOR RAM
15	6	8581169	ADAPTOR
16	1	8581241	EXTENSION ADAPTOR
17	1	8581544	SWIVEL ADAPTOR
18	1	8650108	BONDED SEAL

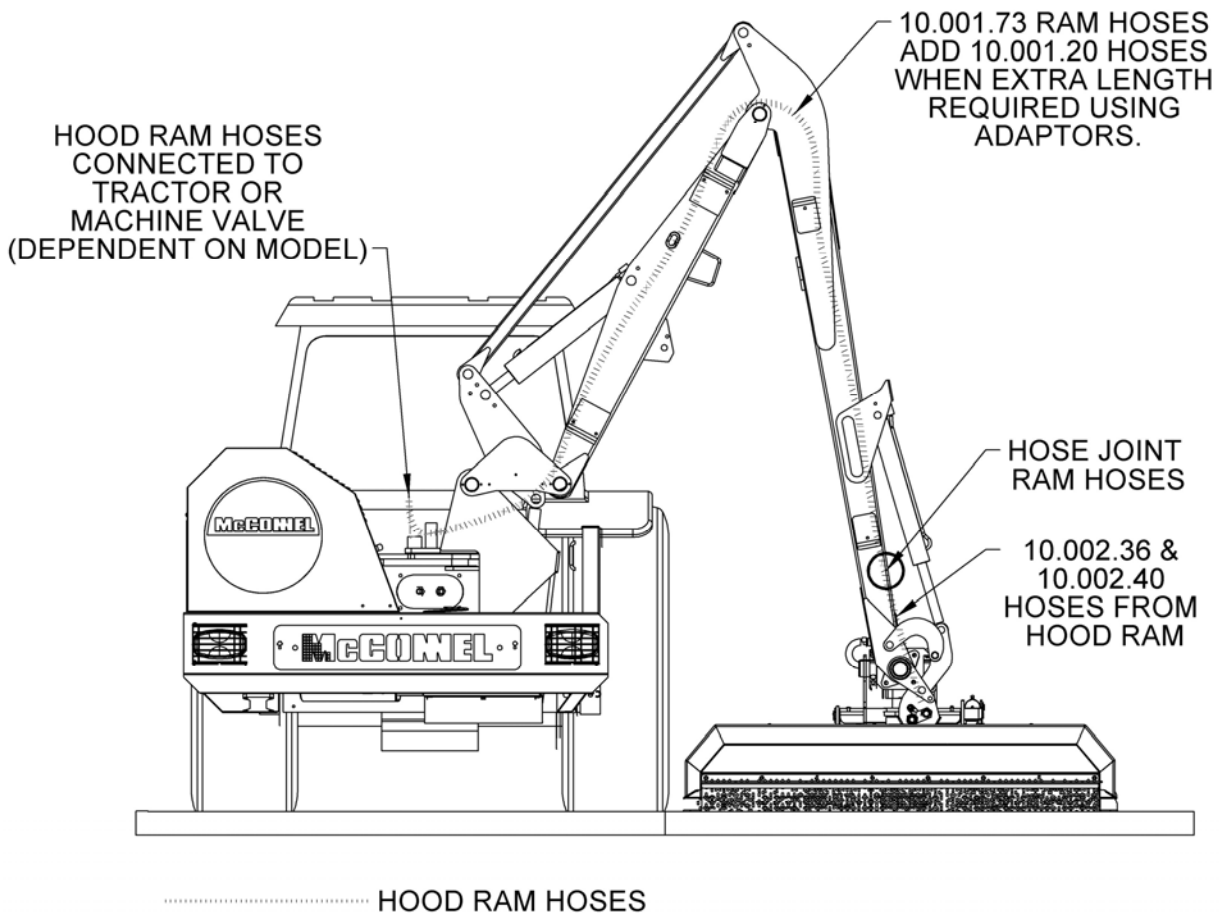

Module(s): 1039744

FIT 1" BSP HOSES THROUGH HOSE SLEEVING BEFORE CONNECTING TO JUNCTION BRACKET.

FIT BLANKING PLUGS TO HOSES

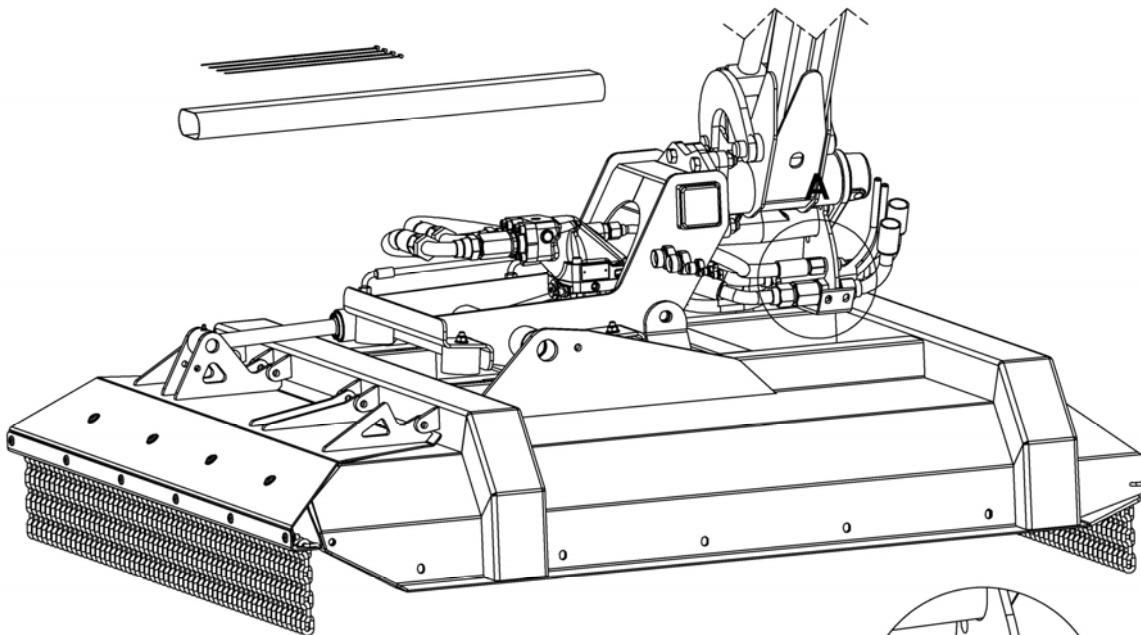
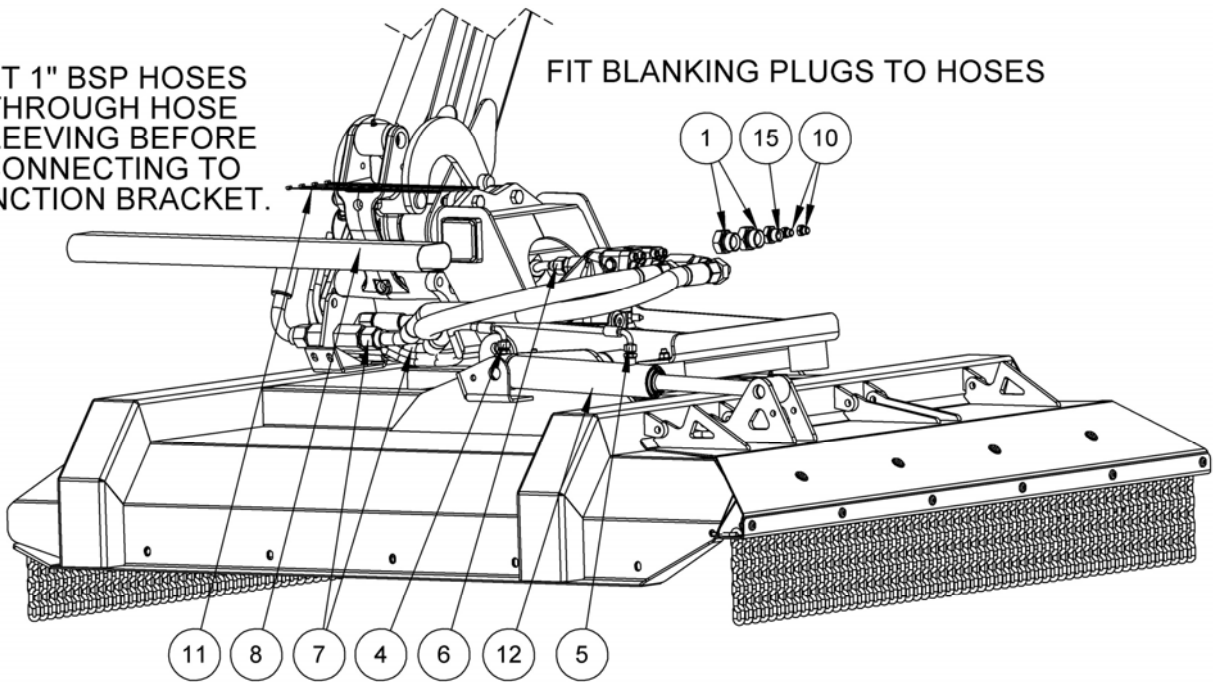

1/4" BSP HOSES RUN IN SLEEVING AS THEY PASS THROUGH THE JUNCTION BRACKET

Module(s): 1039744

REF.	QTY.	PART No.	DESCRIPTION
		<b>1039744</b>	<b>HYDRAULIC INSTALLATION (PISTON)</b>
1	2	05.433.03	BLANKING PLUG C/W CONE
2	4	10.001.20	HOSE - 1/4" BSP FS/FS x 1000mm
3	2	10.001.73	HOSE - 1/4" BSP FS/FS x 6300mm
4	1	10.002.37	HOSE - 1/4" BSP FS/F90 x 2700mm
5	1	10.002.40	HOSE - 1/4" BSP FS/F90 x 3000mm
6	1	10.020.05	HOSE - 5/8" BSP FS/F135 x 500mm
7	2	21270.21	HOSE - 1" BSP FS/F135 x 1100mm
8	1	22590.16	HOSE SLEEVING - 800mm
9	1	22591.03	HOSE SLEEVING - 150mm
10	2	520378	ADAPTOR PLUG
11	4	7196045	HOSE TIE
12	1	7560356	COMPENSATOR RAM
13	6	8581169	ADAPTOR
14	1	8581241	EXTENSION ADAPTOR
15	1	8581351	BLANKING PLUG
16	1	8650108	BONDED SEAL

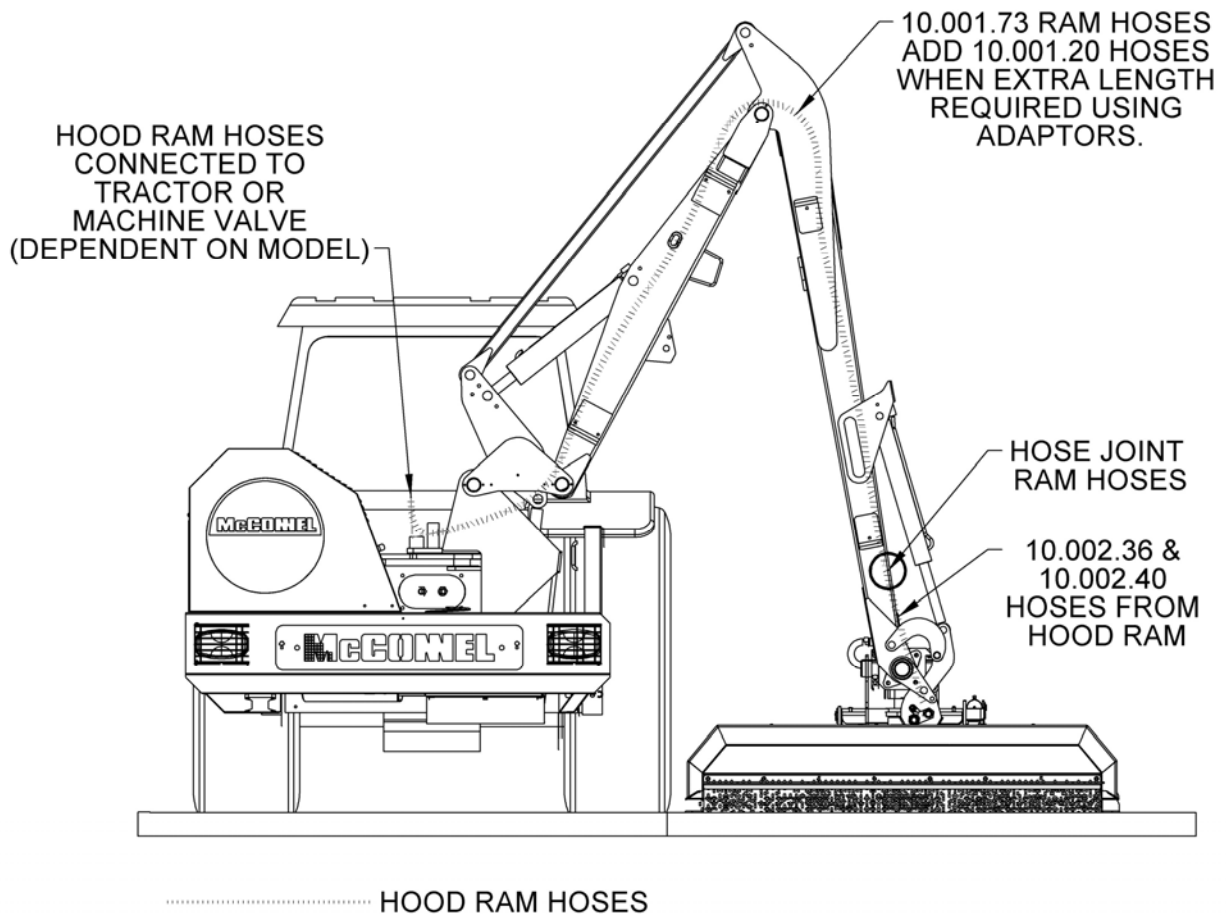

# HYDRAULIC INSTALLATION – 1.5M Gear Model

Module(s): 1039719

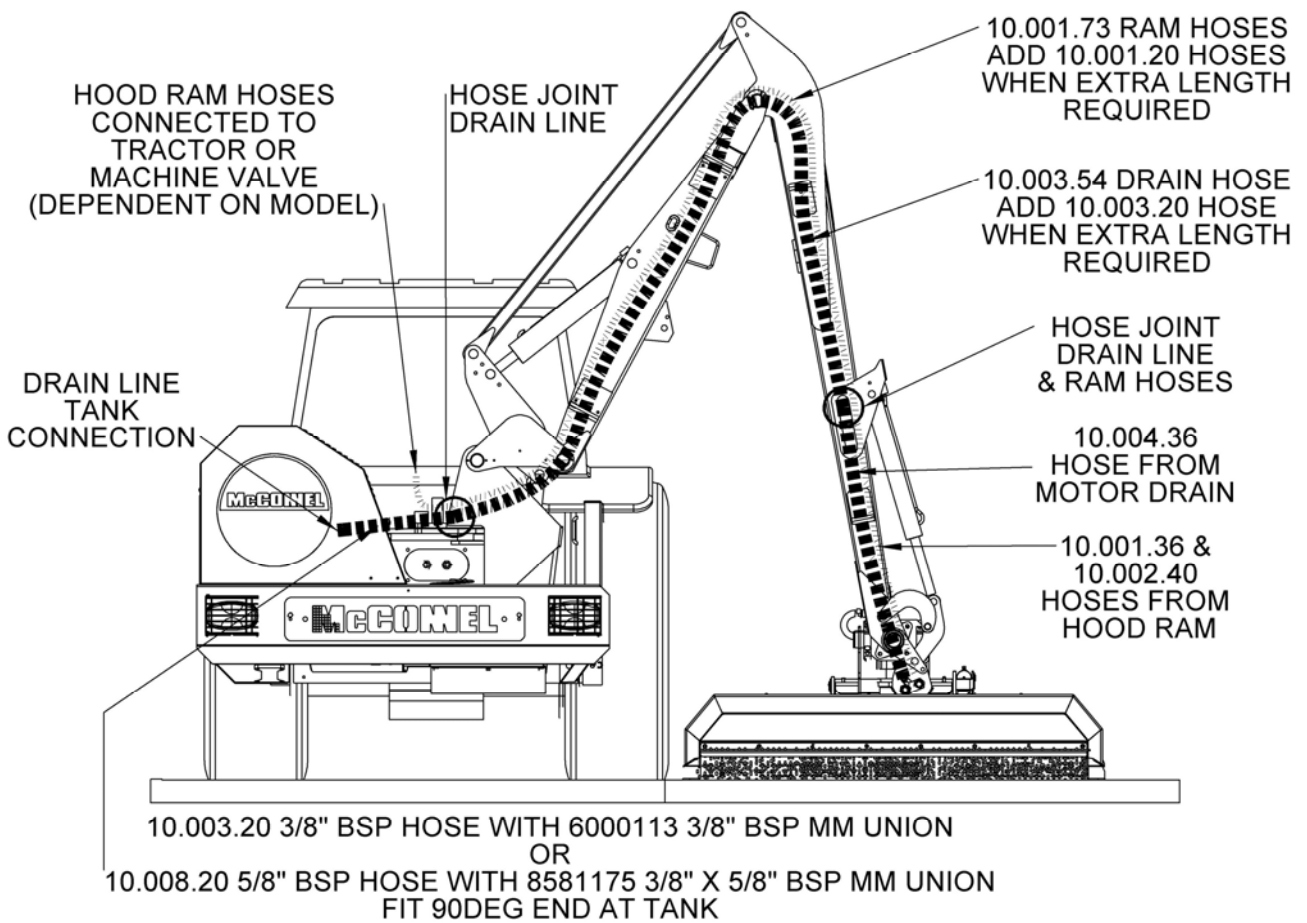
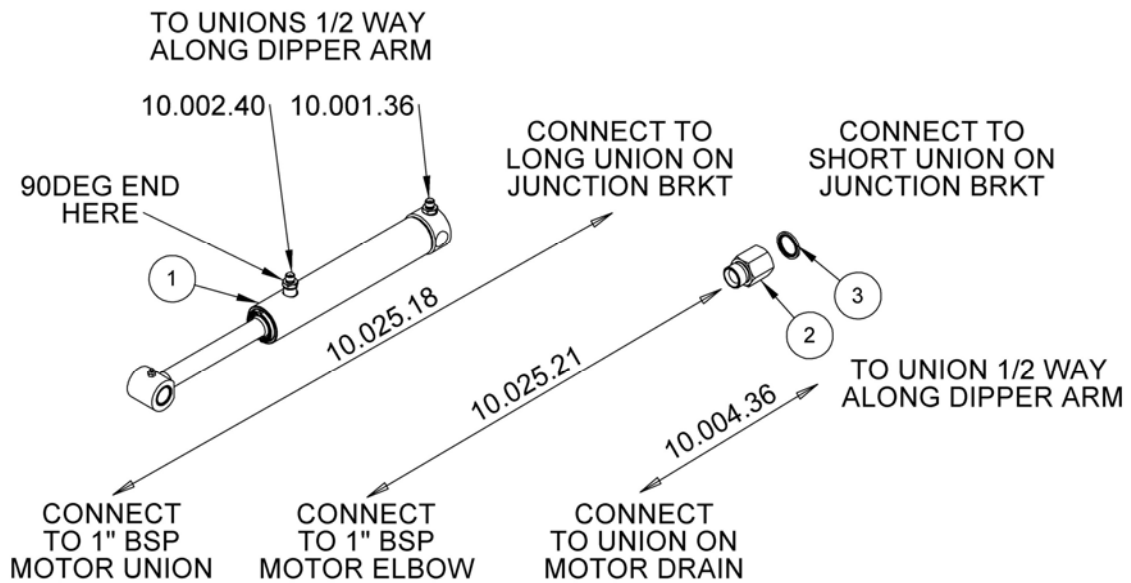

- ████████████████████ HYD.MOTOR DRAIN LINE HOSES
- ..... HOOD RAM HOSES

Module(s): 1039719

REF.	QTY.	PART No.	DESCRIPTION
		<b>1039719</b>	<b>HYDRAULIC INSTALLATION (GEAR)</b>
1	1	7560356	COMPENSATOR RAM
2	1	8581241	EXTENSION ADAPTOR
3	1	8650108	BONDED SEAL
4	4	6000113	ADAPTOR
5	1	8581175	ADAPTOR
6	6	8581169	ADAPTOR
7	1	10.004.36	HOSE - 3/8" BSP FS/F90 x 2600mm
8	1	10.025.18	HOSE - 1" BSP FS/F135 x 900mm
9	1	10.025.21	HOSE - 1" BSP FS/F135 x 1100mm
10	1	10.001.36	HOSE - 1/4" BSP FS/FS x 2600mm
11	1	10.002.40	HOSE - 1/4" BSP FS/F90 x 3000mm
12	1	10.003.54	HOSE - 3/8" BSP FS/FS x 4500mm
13	2	10.003.20	HOSE - 3/8" BSP FS/FS x 1000mm
14	1	10.008.20	HOSE - 5/8" BSP FS/F90 x 1000mm
15	2	10.001.73	HOSE - 1/4" BSP FS/FS x 6300mm
16	4	10.001.20	HOSE - 1/4" BSP FS/FS x 1000mm

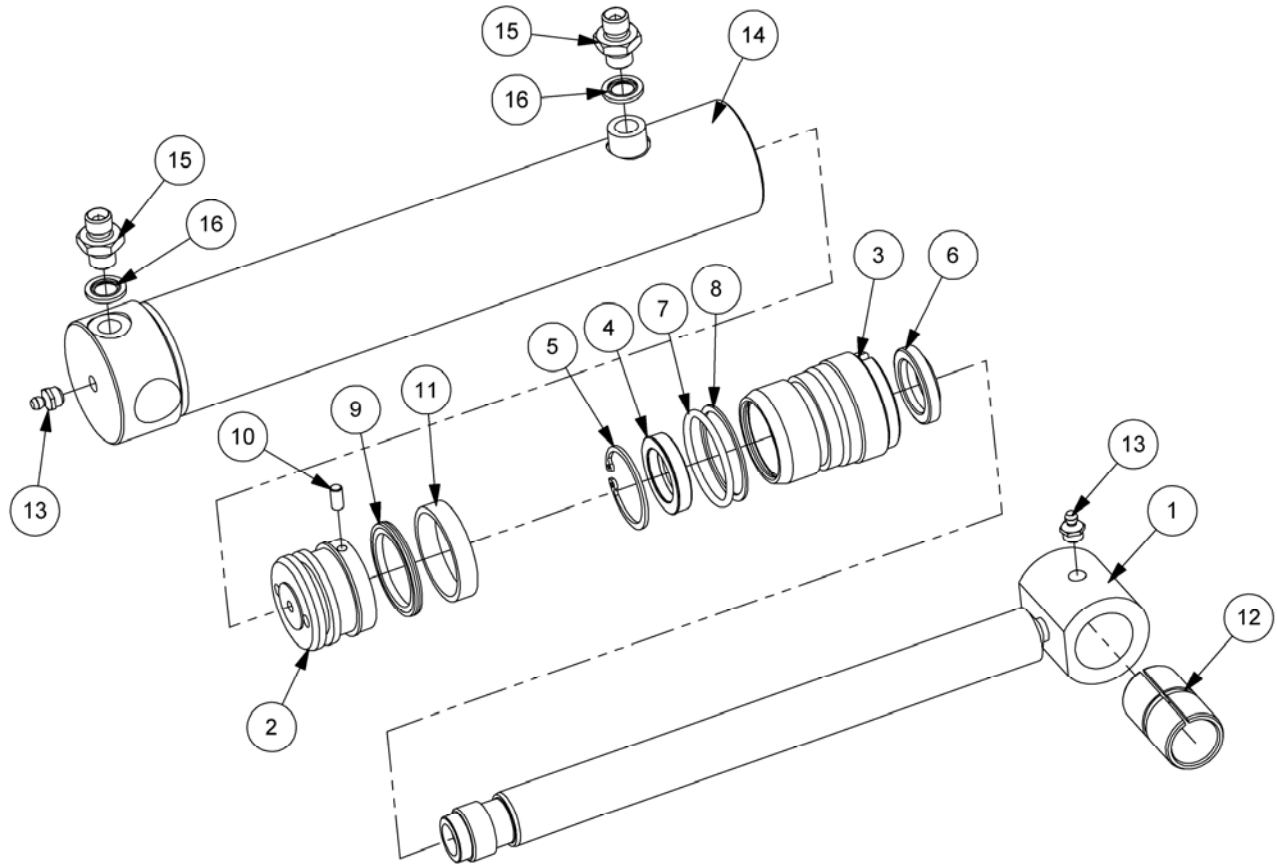

REF.	QTY.	PART No.	DESCRIPTION
		<b>7560356</b>	<b>HYDRAULIC RAM ASSEMBLY</b>
1	1	7195010	PISTON ROD
2	1	7560095	PISTON
3	1	7135291	GLAND HOUSING
4	1	8629148	GLAND SEAL
5	1	0416240	INTERNAL CIRCLIP
6	1	8629149	SCRAPER RING
7	1	8600302	O RING
8	1	8609302	AE RING
9	1	8629187	PISTON SEAL
10	1	9363023	GRUB SCREW
11	1	8629188	GUIDE RING
12	1	7105050	ROD END BUSH
13	2	0901121	GREASE NIPPLE
14	1	7195305	BARREL
15	2	8581169	ADAPTOR
16	2	8650102	BONDED SEAL
		<b>8699188</b>	<b>SEAL KIT</b>

# STOP MODULE

Module(s): 1039720

# McCONEL

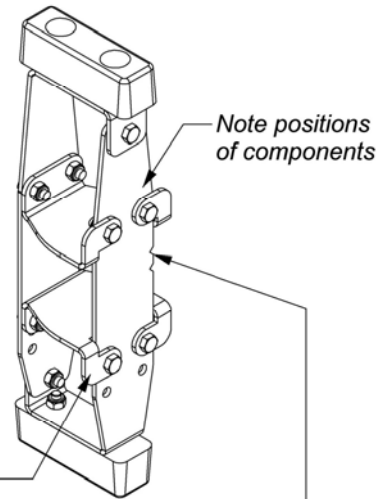
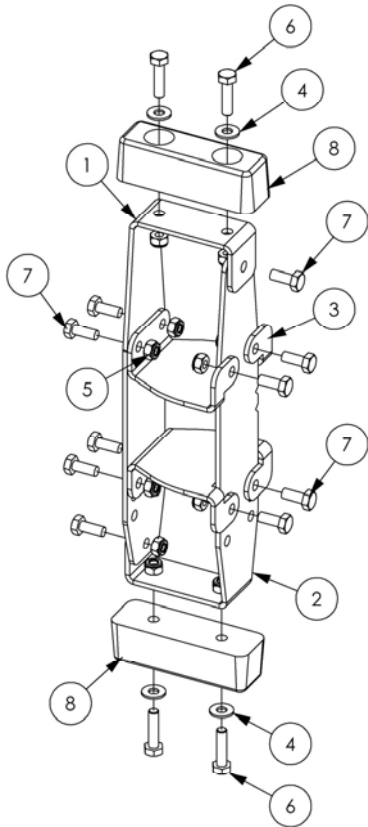

Note positions of components

ASSEMBLED FOR:  
100MM SQUARE ARM SECTION

ASSEMBLY NOTE:  
The notches should be nearest to the top of the dipper arm and facing towards the head pivot tube.

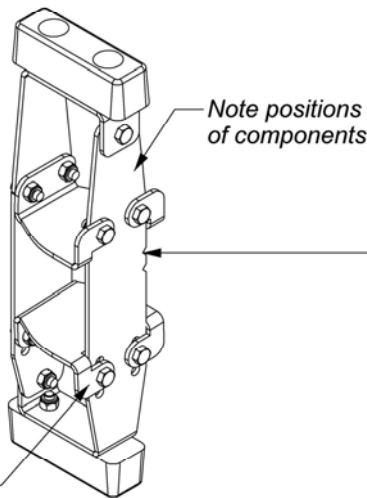

Note positions of components

ASSEMBLED FOR:  
100MM WIDE TAPERED ARM SECTION

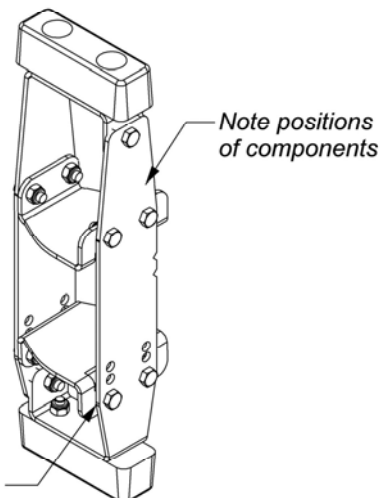

Note positions of components

ASSEMBLED FOR:  
110MM WIDE TAPERED ARM SECTION

REF.	QTY.	PART No.	DESCRIPTION
		<b>1039720</b>	<b>STOP MODULE</b>
1	1	22425.01	STOP PRESSING - TOP
2	1	22425.02	STOP PRESSING - BOTTOM
3	2	22426.01	STOP MOUNTING PRESSING
4	4	9100105	FLAT WASHER
5	14	9163005	NYLOC NUT
6	4	9213085	BOLT
7	10	9313055	SETSCREW
8	2	T7879	RUBBER BUFFER



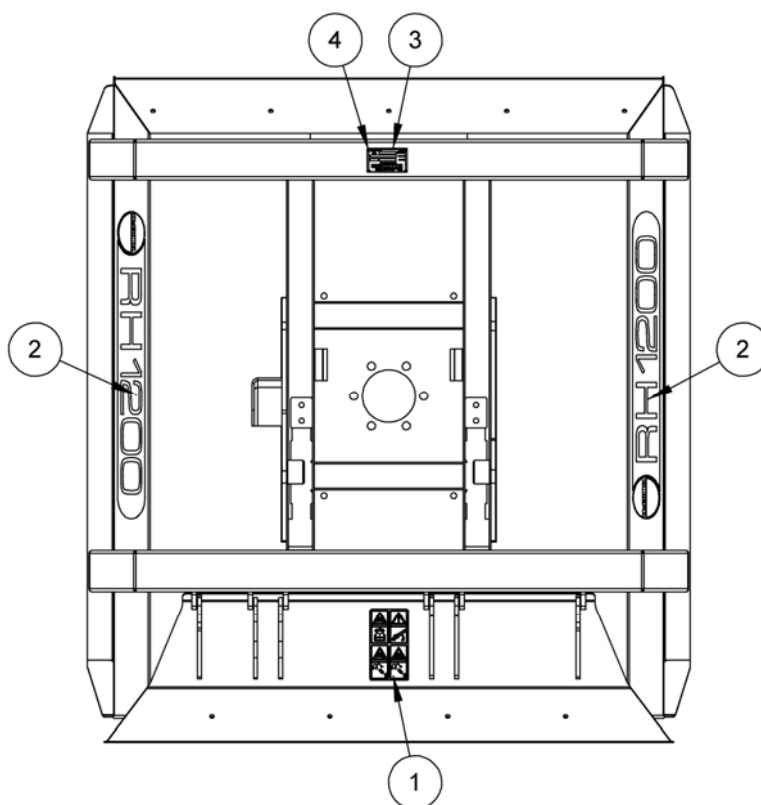
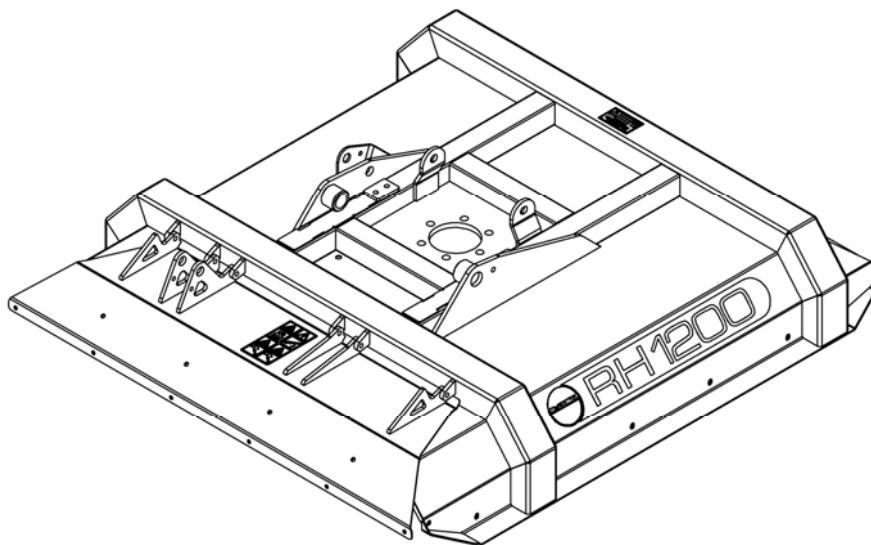

REF.	QTY.	PART No.	DESCRIPTION
		<b>1039743</b>	<b>DECAL KIT - 1.2M ROTARY HEAD</b>
1	1	09.821.35	COMBINED EURO DECAL
2	2	1290935	DECAL - RH1200
3	1	1335246	SERIAL No. PLATE
4	4	7103230	POP RIVET

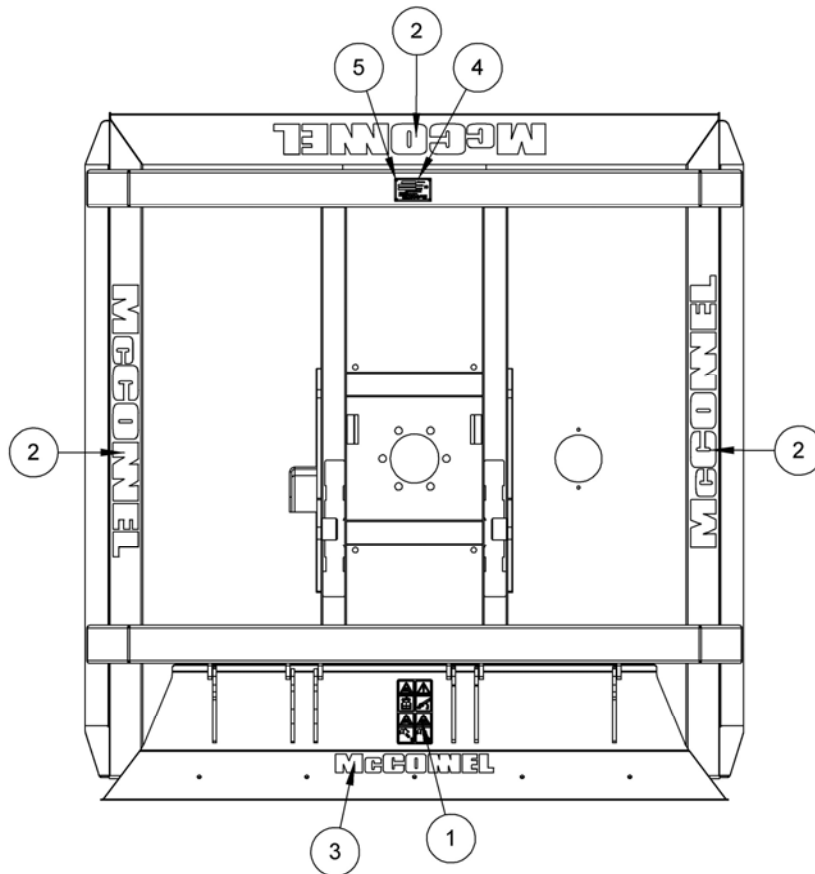
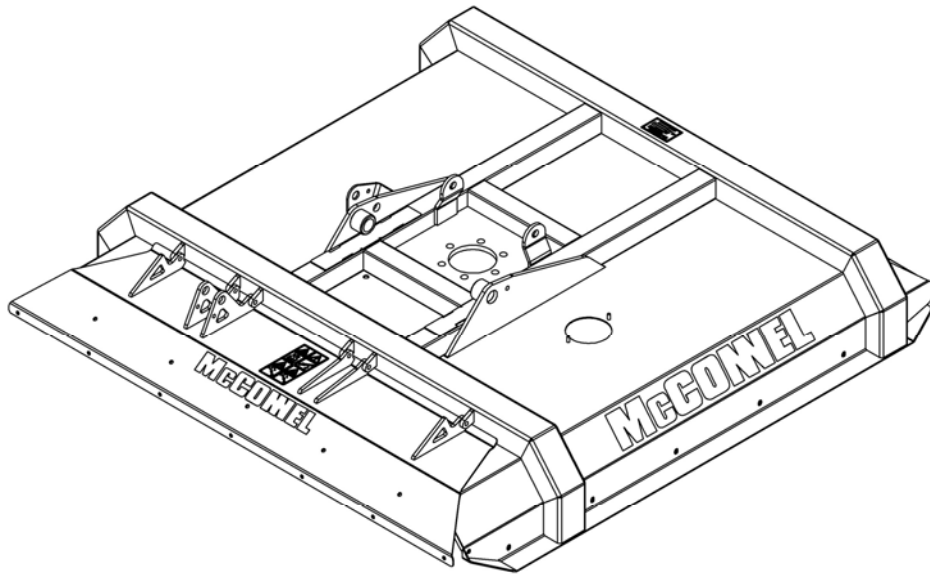

REF.	QTY.	PART No.	DESCRIPTION
		<b>1039721</b>	<b>DECAL KIT - 1.5M ROTARY HEAD</b>
1	1	09.821.35	DECAL - COMBINED EURO DECAL
2	3	1290533	DECAL- MCCONNEL (BLACK)
3	1	1290255	DECAL - MCCONNEL (BLACK)
4	1	1335246	SERIAL No. PLATE
5	4	7103230	POP RIVET





McConnel Limited, Temeside Works, Ludlow, Shropshire SY8 1JL. England.  
Telephone: 01584 873131. Facsimile: 01584 876463. [www.mcconnel.com](http://www.mcconnel.com)