

Publication 713  
April 2012  
Part No. 22675.13  
Revised: 14.03.18



# ROTARY HEAD RH1200 & RH1500

**Medium Duty Builds:**  
1039980, 1039919, 1039993 & Variants

Operator Manual



# IMPORTANT

## VERIFICATION OF WARRANTY REGISTRATION



### Dealer Warranty Information & Registration Verification

It is imperative that the selling dealer registers this machine with McConnel Limited before delivery to the end user – failure to do so may affect the validity of the machine warranty.

To register machines; log onto <https://my.mcconnel.com> and select 'Machine Registration' which can be found in the 'Warranty' section of the site. **Confirm to the customer that the machine has been registered by completing the verification form below.**

<b>Registration Verification</b>	Serial No. <input type="text"/>
Dealer Name: .....	
Dealer Address: .....	
Customer Name: .....	
Date of Warranty Registration: ...../...../.....	Dealer Signature: .....

### Note to Customer / Owner

Please ensure the section above has been completed and signed by the dealer to verify your machine has been registered with McConnel Limited.

**IMPORTANT:** During the initial 'bedding in' period of a new machine it is the customer's responsibility to regularly inspect all nuts, bolts and hose connections for tightness and re-tighten if required. New hydraulic connections occasionally weep small amounts of oil as the seals and joints settle in – where this occurs it can be cured by re-tightening the connection – *refer to torque settings chart below*. The tasks stated above should be performed on an hourly basis during the first day of work and at least daily thereafter as part of the machine's general maintenance procedure.

CAUTION: DO NOT OVER TORQUE HYDRAULIC FITTINGS AND HOSES

### Torque Settings for Hydraulic Fittings

Hydraulic Hose Ends		
BSP	Setting	Metric
1/4"	18 Nm	19 mm
3/8"	31 Nm	22 mm
1/2"	49 Nm	27 mm
5/8"	60 Nm	30 mm
3/4"	80 Nm	32 mm
1"	125 Nm	41 mm
1.1/4"	190 Nm	50 mm
1.1/2"	250 Nm	55 mm
2"	420 Nm	70 mm

Port Adaptors with Bonded Seals		
BSP	Setting	Metric
1/4"	34 Nm	19 mm
3/8"	47 Nm	22 mm
1/2"	102 Nm	27 mm
5/8"	122 Nm	30 mm
3/4"	149 Nm	32 mm
1"	203 Nm	41 mm
1.1/4"	305 Nm	50 mm
1.1/2"	305 Nm	55 mm
2"	400 Nm	70 mm





# WARRANTY POLICY

## WARRANTY REGISTRATION

All machines must be registered, by the selling dealer with McConnel Ltd, before delivery to the end user. On receipt of the goods it is the buyer's responsibility to check that the Verification of Warranty Registration in the Operator's Manual has been completed by the selling dealer.

### 1. LIMITED WARRANTIES

- 1.01. *All mounted machines supplied by McConnel Ltd are warranted to be free from defects in material and workmanship from the date of sale to the original purchaser for a period of 12 months, unless a different period is specified.  
All Self Propelled Machines supplied by McConnel Ltd are warranted to be free from defects in material and workmanship from the date of sale to the original purchaser for a period of 12 months or 1500 hours. Engine warranty will be specific to the Manufacturer of that unit.*
- 1.02. *All spare parts supplied by McConnel Ltd and purchased by the end user are warranted to be free from defects in material and workmanship from the date of sale to the original purchaser for a period of 6 months. All parts warranty claims must be supported by a copy of the failed part invoice to the end user. We cannot consider claims for which sales invoices are not available.*
- 1.03. *The warranty offered by McConnel Ltd is limited to the making good by repair or replacement for the purchaser any part or parts found, upon examination at its factory, to be defective under normal use and service due to defects in material or workmanship. Returned parts must be complete and unexamined. Pack the component(s) carefully so that any transit damage is avoided. All ports on hydraulic items should be drained of oil and securely plugged to prevent seepage and foreign body ingress. Certain other components, electrical items for example, may require particular care when packing to avoid damage in transit.*
- 1.04. *This warranty does not extend to any product from which McConnel Ltd's serial number plate has been removed or altered.*
- 1.05. *The warranty policy is valid for machines registered in line with the terms and conditions detailed and on the basis that the machines do not extend a period of 24 months or greater since their original purchase date, that is the original invoice date from McConnel Limited.  
Machines that are held in stock for more than 24 months cannot be registered for warranty.*
- 1.06. *This warranty does not apply to any part of the goods, which has been subjected to improper or abnormal use, negligence, alteration, modification, fitment of non-genuine parts, accident damage, or damage resulting from contact with overhead power lines, damage caused by foreign objects (e.g. stones, iron, material other than vegetation), failure due to lack of maintenance, use of incorrect oil or lubricants, contamination of the oil, or which has served its normal life. This warranty does not apply to any expendable items such as blades, belts, clutch linings, filter elements, flails, flap kits, skids, soil engaging parts, shields, guards, wear pads, pneumatic tyres or tracks.*
- 1.07. *Temporary repairs and consequential loss - i.e. oil, downtime and associated parts are specifically excluded from the warranty.*
- 1.08. *Warranty on hoses is limited to 12 months and does not include hoses which have suffered external damage. Only complete hoses may be returned under warranty, any which have been cut or repaired will be rejected.*
- 1.09. *Machines must be repaired immediately a problem arises. Continued use of the machine after a problem has occurred can result in further component failures, for which McConnel Ltd cannot be held liable, and may have safety implications.*
- 1.10. *If in exceptional circumstances a non McConnel Ltd part is used to effect a repair, warranty reimbursement will be at no more than McConnel Ltd's standard dealer cost for the genuine part.*

- 1.11. *Except as provided herein, no employee, agent, dealer or other person is authorised to give any warranties of any nature on behalf of McConnell Ltd.*
- 1.12. *For machine warranty periods in excess of 12 months the following additional exclusions shall apply:*
  - 1.12.1. *Hoses, exposed pipes and hydraulic tank breathers.*
  - 1.12.2. *Filters.*
  - 1.12.3. *Rubber mountings.*
  - 1.12.4. *External electric wiring.*
  - 1.12.5. *Bearings and seals*
  - 1.12.6. *External Cables, Linkages*
  - 1.12.7. *Loose/Corroded Connections, Light Units, LED's*
  - 1.12.8. *Comfort items such as Operator Seat, Ventilation, Audio Equipment*
- 1.13. *All service work, particularly filter changes, must be carried out in accordance with the manufacturer's service schedule. Failure to comply will invalidate the warranty. In the event of a claim, proof of the service work being carried out may be required.*
- 1.14. *Repeat or additional repairs resulting from incorrect diagnosis or poor quality previous repair work are excluded from warranty.*

***NB Warranty cover will be invalid if any non-genuine parts have been fitted or used. Use of non-genuine parts may seriously affect the machine's performance and safety. McConnell Ltd cannot be held responsible for any failures or safety implications that arise due to the use of non-genuine parts.***

## **2. REMEDIES AND PROCEDURES**

- 2.01. *The warranty is not effective unless the Selling Dealer registers the machine, via the McConnell web site and confirms the registration to the purchaser by completing the confirmation form in the operator's manual.*
- 2.02. *Any fault must be reported to an authorised McConnell Ltd dealer as soon as it occurs. Continued use of a machine, after a fault has occurred, can result in further component failure for which McConnell Ltd cannot be held liable.*
- 2.03. *Repairs should be undertaken within two days of the failure. Claims submitted for repairs undertaken more than 2 weeks after a failure has occurred, or 2 days after the parts were supplied will be rejected, unless the delay has been authorised by McConnell Ltd. Please note that failure by the customer to release the machine for repair will not be accepted as a reason for delay in repair or submitting warranty claims.*
- 2.04. *All claims must be submitted, by an authorised McConnell Ltd Service Dealer, within 30 days of the date of repair.*
- 2.05. *Following examination of the claim and parts, McConnell Ltd will pay, at their discretion, for any valid claim the invoiced cost of any parts supplied by McConnell Ltd and appropriate labour and mileage allowances if applicable.*
- 2.06. *The submission of a claim is not a guarantee of payment.*
- 2.07. *Any decision reached by McConnell Ltd. is final.*

## **3. LIMITATION OF LIABILITY**

- 3.01. *McConnell Ltd disclaims any express (except as set forth herein) and implied warranties with respect to the goods including, but not limited to, merchantability and fitness for a particular purpose.*
- 3.02. *McConnell Ltd makes no warranty as to the design, capability, capacity or suitability for use of the goods.*
- 3.03. *Except as provided herein, McConnell Ltd shall have no liability or responsibility to the purchaser or any other person or entity with respect to any liability, loss, or damage caused or alleged to be caused directly or indirectly by the goods including, but not limited to, any indirect, special, consequential, or incidental damages resulting from the use or operation of the goods or any breach of this warranty. Notwithstanding the above limitations and warranties, the manufacturer's liability hereunder for damages incurred by the purchaser or others shall not exceed the price of the goods.*
- 3.04. *No action arising out of any claimed breach of this warranty or transactions under this warranty may be brought more than one (1) year after the cause of the action has occurred.*

#### **4. MISCELLANEOUS**

- 4.01. McConnel Ltd may waive compliance with any of the terms of this limited warranty, but no waiver of any terms shall be deemed to be a waiver of any other term.*
- 4.02. If any provision of this limited warranty shall violate any applicable law and is held to be unenforceable, then the invalidity of such provision shall not invalidate any other provisions herein.*
- 4.03. Applicable law may provide rights and benefits to the purchaser in addition to those provided herein.*

---

*McConnel Limited*



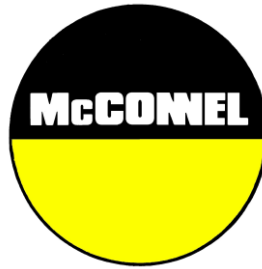

*For Safety and Performance...*

**ALWAYS READ THE BOOK FIRST**

**McCONEL LIMITED**

**Temeside Works  
Ludlow  
Shropshire  
England**

**Telephone: +44 (0)1584 873131  
www.mcconel.com**

---

**- NOISE STATEMENT -**

The equivalent daily personal noise exposure from this machine measured at the operators' ear is within the range 78 – 85 dB, these figures apply to a normal distribution of use where the noise fluctuates between zero and maximum. The figures assume that the machine is fitted to a tractor with a 'quiet' cab with the windows closed in a generally open environment. We recommend that the windows are kept closed. With the cab rear window open the equivalent daily personal noise exposure will increase to a figure within the range 82 – 88 dB. At an equivalent daily noise exposure level of 85 – 90 dB ear protection is recommended and must always be used if any window is left open.



Operating, servicing and maintaining this equipment can expose you to chemicals including gasoline, diesel fuel, lubricants, petroleum products, engine exhaust, carbon monoxide, and phthalates, which are known to the State of California to cause cancer and birth defects or other reproductive harm. To minimize exposure, avoid breathing exhaust, do not idle the engine except as necessary, service your vehicle in a well-ventilated area and wear gloves or wash your hands frequently when servicing your vehicle. Battery posts, terminals and related accessories contain lead and lead compounds, chemicals known to the state of California to cause cancer, birth defects or other reproductive harm. For more information go to [www.P65Warnings.ca.gov](http://www.P65Warnings.ca.gov). This website, operated by California's Office of Environmental Health Hazard Assessment, provides information about these chemicals and how individuals may be exposed to them.





# CONTENTS

---

General Information	1
Machine Overview & Purpose of Use	2
Machine Identification	2
Specifications	3
Component Location & Identification	4
Safety Information	5
Safety Decals	9
Vehicle / Tractor Preparation	10
Machine Attachment	11
Operation	12
Operating with Lift Float	18
Transportation	19
Maintenance	20



## GENERAL INFORMATION

---

Read this manual before fitting or operating the machine or accessory. Whenever any doubt exists contact your local dealer or the McConnell Service Department for assistance.

**Only use 'Genuine McConnell Parts' on McConnell machinery and equipment.**

DEFINITIONS: *The following definitions apply throughout this manual;*

### **⚠ DANGER**

**DANGER:** Alerts to a hazardous situation which will result in death or serious injury if not observed carefully.

### **⚠ WARNING**

**WARNING:** Alerts to a hazardous situation which could result in death or serious injury if not observed carefully.

### **⚠ CAUTION**

**CAUTION:** Alerts to a hazardous situation which could result in damage to the machine and/or equipment if not observed carefully.

### **NOTICE**

**NOTICE:** Specific or general information considered important or useful to emphasise.

**LEFT HAND (LH) & RIGHT HAND (RH):** *These terms are applicable to the machine when fitted to the tractor and viewed from the rear; these terms also apply to tractor references.*

### SERIAL PLATE

*All machines are equipped with a serial number plate containing important information relating to the machine including a unique serial number used for identification purposes.*

*Note: Images in this manual are provided for instruction and informational purposes only and may not show components in their entirety. In certain instances images may appear different to the actual machine; where this occurs the general procedure will be basically the same. E&OA.*

## MACHINE & DEALER INFORMATION

Record the serial number of your machine on this page and always quote it when ordering parts. Whenever information concerning the machine is requested remember to also state the make and model of tractor to which the machine is fitted.	
Machine Serial Number:	Installation Date:
Machine Model Details:	
Dealer Name & Branch:	
Dealer Address:	
Dealer Telephone No:	
Dealer Email Address:	

## MACHINE OVERVIEW & PURPOSE OF USE

These machines are medium duty rotary cutting heads available in working widths of 1.2m and 1.5m. Machines are available with a choice of either blade or chain type cutting units with the latter offering the option of using either 10mm or 13mm chain sets.

The machines are primarily designed for use in cutting scrub, brush and foliage of up to 100mm (4") in diameter or multiple branches that have a total cross section area of equivalent size.

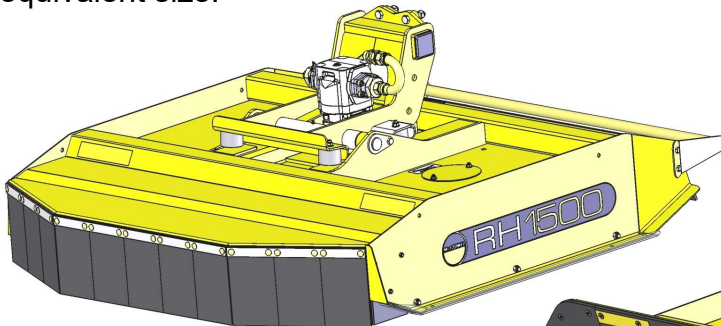

RH1500 Medium Duty (Blade Model)

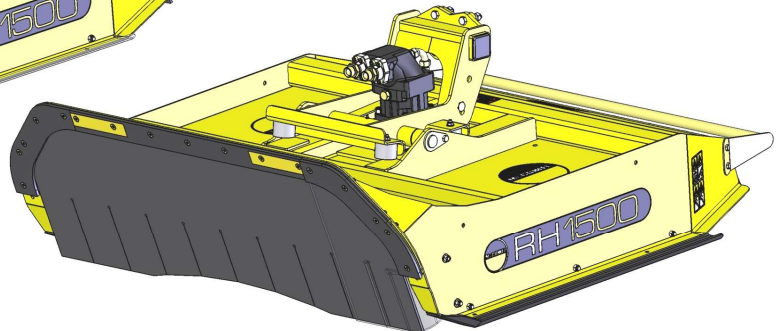

RH1500 Medium Duty (Chain Model)

Examples of Low and High Front variants shown

*These machines should only be used to perform tasks for which they were designed; use of the machine for any other function or purpose may be dangerous to persons and damaging to components and must therefore be avoided.*

## MACHINE IDENTIFICATION

Each machine is fitted with an identification plate stating important information about the machine, this information will include:

1. **Model/Code** (Part Number)
2. **Serial Number**

When ordering spares or replacement parts from your local dealer it is important to quote machine part number and serial number as stated on the identification plate so the machine and model can be quickly and correctly identified.

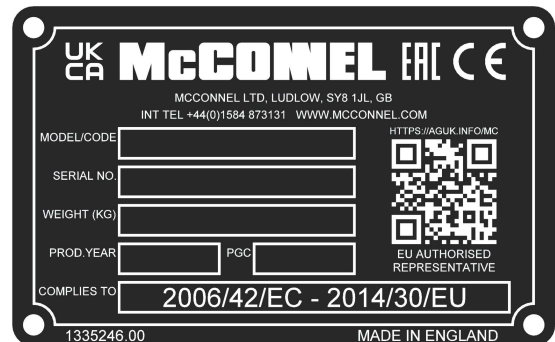

**Machine Identification Plate**

The identification plate should also be referred to in order to determine the exact weight of the unit for reasons of handling and attachment.

### Service & Replacement Parts

To obtain accurate parts information for your machine please refer to the 'Interactive Parts Database' on our website which will identify the exact components used on the machine based on its unique serial number.

Direct access can be gained via the following web address or QR code;

<http://www.mcconnell.com/support/product-support/interactive-parts-database/>





## SPECIFICATIONS

<b>RH1200 'Low Front' Machine</b>	<b>RH1200 Blade Model</b>	<b>RH1200 Chain Model</b>
Working Width	1200mm	1200mm
Machine Length	1720mm	1720mm
Machine Width	1543mm	1543mm
Machine Height	719mm	719mm
Deck Height – Min. / Max.	260mm / 285mm	260mm / 285mm
Cutter Type	Tri Blade	10mm or 13mm Chains
Hydraulic Motor Options	Yes	Yes
Weight	TBA	TBA

<b>RH1200 'High Front' Machine</b>	<b>RH1200 Blade Model</b>	<b>RH1200 Chain Model</b>
Working Width	1200mm	1200mm
Machine Length	1899mm	1899mm
Machine Width	1469mm	1469mm
Machine Height	744mm	744mm
Deck Height – Min. / Max.	285mm / 310mm	285mm / 310mm
Cutter Type	Tri Blade	10mm or 13mm Chains
Hydraulic Motor Options	Yes	Yes
Weight	TBA	TBA

<b>RH1500 'Low Front' Machine</b>	<b>RH1500 Blade Model</b>	<b>RH1500 Chain Model</b>
Working Width	1500mm	1500mm
Machine Length	1969mm	1969mm
Machine Width	1756mm	1756mm
Machine Height	719mm	719mm
Deck Height – Min. / Max.	260mm / 285mm	260mm / 285mm
Cutter Type	Tri Blade	10mm or 13mm Chains
Hydraulic Motor Options	Yes	Yes
Weight	TBA	TBA

<b>RH1500 'High Front' Machine</b>	<b>RH1500 Blade Model</b>	<b>RH1500 Chain Model</b>
Working Width	1500mm	1500mm
Machine Length	2009mm	2009mm
Machine Width	1773mm	1773mm
Machine Height	744mm	744mm
Deck Height – Min. / Max.	285mm / 310mm	285mm / 310mm
Cutter Type	Tri Blade	10mm or 13mm Chains
Hydraulic Motor Options	Yes	Yes
Weight	TBA	TBA

### Noise Statement

*The equivalent daily personal noise exposure from this machine, measured at the operators' ear, is within the range 78 – 85 DB. These figures apply to a normal distribution of use where the noise fluctuates between zero and maximum. The figures assume that the machine is fitted to a tractor with a quiet cab with the windows closed in a generally open environment. We recommend that the windows are kept closed. With the cab rear window open the equivalent daily personal noise exposure will increase to a figure within the range 82 – 88 DB. At equivalent daily noise exposure levels of between 85 and 90 DB, ear protection is recommended, it should be used if any window is left open.*

# COMPONENT LOCATION & IDENTIFICATION

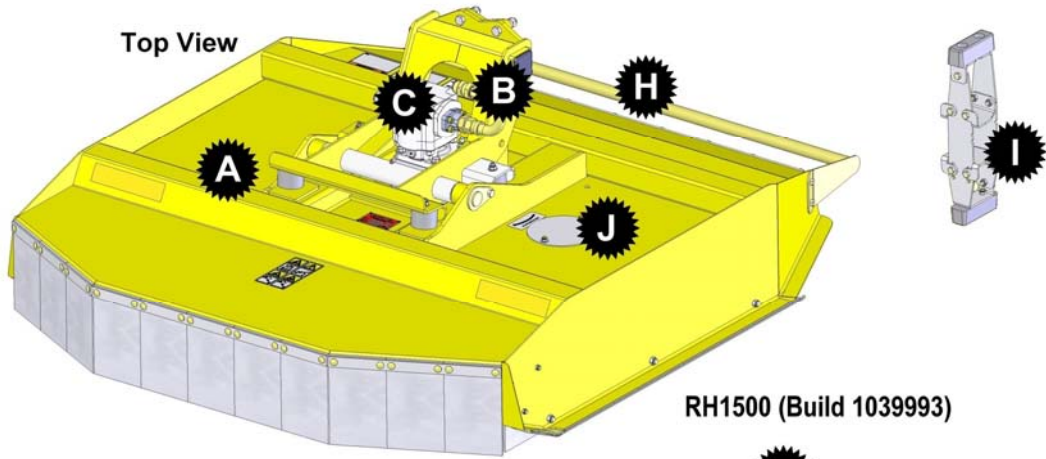

- A) Deck
- B) Pivoting Mounting Bracket
- C) Hydraulic Motor
- D) Blade Cutting Unit
- E) Side Skids
- F) Front Flaps
- G) Rear Flap
- H) Guard Rail
- I) Stop Assembly
- J) Blade Access

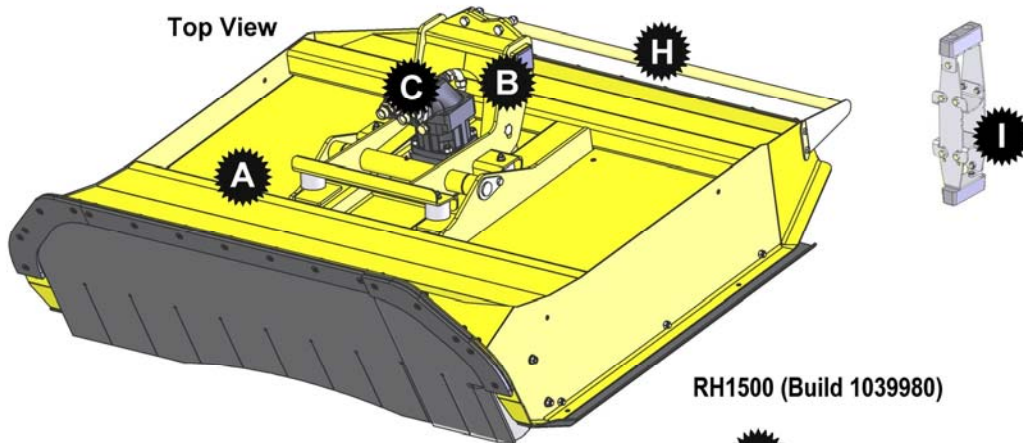
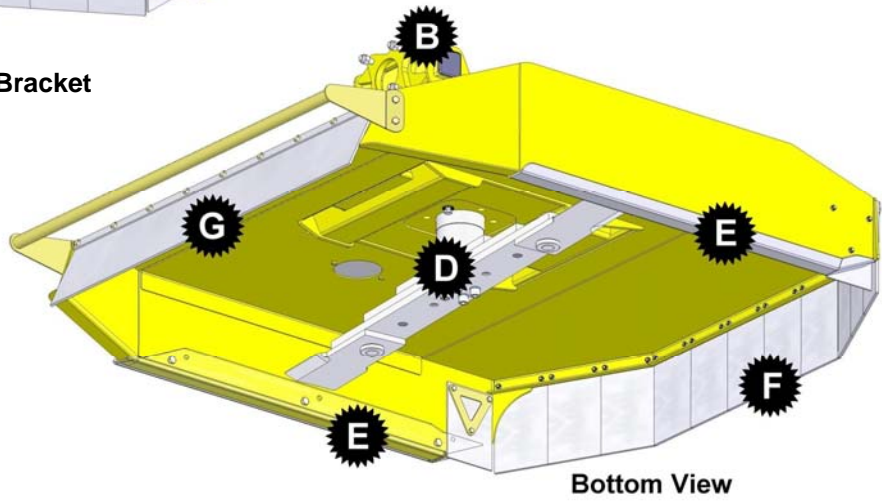

- A) Deck
- B) Pivoting Mounting Bracket
- C) Hydraulic Motor
- D) Chain Cutting Unit
- E) Side Skids
- F) Front Flaps
- G) Rear Flap
- H) Guard Rail
- I) Stop Assembly

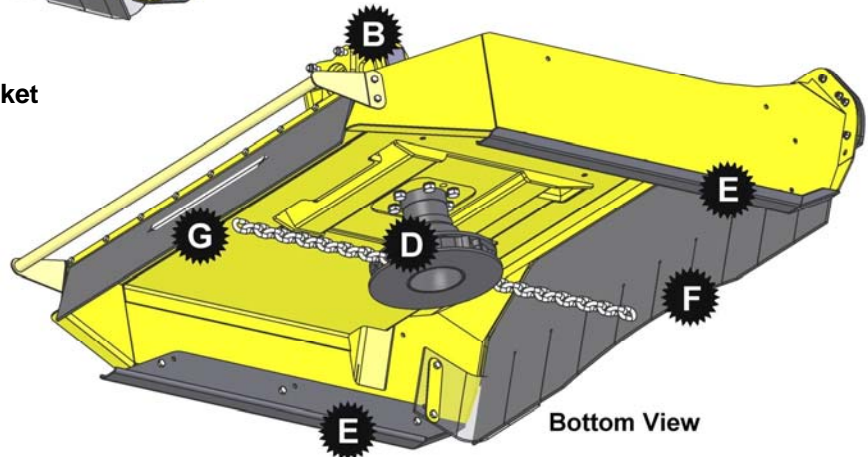



This component/accessory is primarily designed for fitment to McConnel Power Arms, therefore all safety aspects for this component relate to the safe use of those machines and will be stated in the safety section of its operation manual. A copy of the same safety information is provided below in order to reiterate and refresh your memory.

This machine has the potential to be extremely dangerous, in the wrong hands it can kill or maim. It is therefore imperative that the owner, and the operator of this machine, read the following section to ensure that they are both fully aware of the dangers that do, or may exist, and their responsibilities surrounding its use.

The operator of this machine is responsible not only for their own safety but equally for the safety of others who may come into the close proximity of the machine, as the owner you are responsible for both.

### **POTENTIAL SIGNIFICANT DANGERS ASSOCIATED WITH THE USE OF A MACHINE:**

- ▲ *Being hit by debris thrown by rotating components.*
- ▲ *Being hit by machine parts ejected through damage during use.*
- ▲ *Being caught on a rotating power take-off (PTO) shaft.*
- ▲ *Being caught in other moving parts i.e.: belts, pulleys and cutting heads.*
- ▲ *Electrocution from Overhead Power Lines (by contact with or 'flashover' from).*
- ▲ *Being hit by cutting heads or machine arms as they move.*
- ▲ *Becoming trapped between tractor and machine when hitching or unhitching.*
- ▲ *Tractor overbalancing when machine arm is extended.*
- ▲ *Injection of high-pressure oil from hydraulic hoses or couplings.*
- ▲ *Machine overbalancing when freestanding (out of use).*
- ▲ *Road traffic accidents due to collision or debris on the road.*

## **BEFORE USING A MACHINE YOU MUST:**

- ▲ *Ensure you read all sections of the operator handbook.*
- ▲ *Ensure the operator is, or has been, properly trained to use the machine.*
- ▲ *Ensure the operator has been issued with and reads the operator handbook.*
- ▲ *Ensure the operator understands and follows the instructions in operator handbook.*
- ▲ *Ensure the tractor front, rear and sides are fitted with metal mesh or polycarbonate guards of suitable size and strength to protect the operator against thrown debris or parts.*
- ▲ *Ensure tractor guards are fitted correctly, are undamaged and kept properly maintained.*
- ▲ *Ensure that all machine guards are in position, are undamaged, and are kept maintained in accordance with the manufacturer's recommendations.*
- ▲ *Ensure that blades and all fixings are genuine components supplied by the manufacturer specifically for the machine and are securely attached with no parts missing or damaged.*
- ▲ *Ensure hydraulic pipes are carefully and correctly routed to avoid damage by chaffing, stretching or pinching and that they are held in place with the correct fittings.*
- ▲ *Always follow the manufacturer's instructions for attachment and removal of the machine from the tractor.*
- ▲ *Check that the machine fittings and couplings are in good condition.*
- ▲ *Ensure the tractor meets the minimum weight recommendations of the machine's manufacturer and that ballast is used as necessary.*
- ▲ *Always inspect the work area thoroughly before starting to note obstacles and remove wire, bottles, cans and other debris.*
- ▲ *Use clear suitably sized warning signs to alert others to the nature of the machine working within that area. Signs should be placed at both ends of the work site. (It is recommended that signs used are of a size and type specified by the Department of Transport and positioned in accordance with their, and the Local Highways Authority, guidelines).*
- ▲ *Ensure the operator is protected from noise. Ear defenders should be worn and tractor cab doors and windows must be kept closed. Machine controls should be routed through proprietary openings in the cab to enable all windows to be shut fully.*
- ▲ *Always work at a safe speed taking account of the conditions i.e.: terrain, highway proximity and obstacles around and above the machine. Extra special attention should be applied to Overhead Power Lines. Some of our machines are capable of reach in excess of 8 metres (26 feet) this means they have the potential to well exceed, by possibly 3 metres (9' 9"), the lowest legal minimum height of 5.2 metres from the ground for 11,000 and 33,000 volt power lines. It cannot be stressed enough the dangers that surround this capability, it is therefore vital that the operator is fully aware of the maximum height and reach of the machine, and that they are fully conversant with all aspects regarding the safe minimum distances that apply when working with machines in close proximity to Power Lines. (Further information on this subject can be obtained from the Health & Safety Executive or your Local Power Company).*

- ▲ *Always disengage the machine, kill the tractor engine, remove and pocket the key before dismounting for any reason.*
- ▲ *Always clear up all debris left at the work area, it may cause hazard to others.*
- ▲ *Always ensure when you remove your machine from the tractor that it is left in a safe and stable position using the stands and props provided and secured if necessary.*

#### **WHEN NOT TO USE THIS MACHINE:**

- ▲ *Never attempt to use this machine if you have not been trained to do so.*
- ▲ *Never use a machine until you have read and understood the operator handbook, are familiar with it, and practiced the controls.*
- ▲ *Never use a machine that is poorly maintained.*
- ▲ *Never use a machine fitted to a tractor that does not have suitable front, rear and side(s) cab guarding made of metal mesh or polycarbonate.*
- ▲ *Never use a machine if guards are missing or damaged.*
- ▲ *Never use a machine on which the hydraulic system shows signs of wear or damage.*
- ▲ *Never fit, or use, a machine on a tractor that does not meet the manufacturer's minimum specification level.*
- ▲ *Never turn a machine cutting head to an angle that causes debris to be ejected towards the cab.*
- ▲ *Never start or continue to work a machine if people are nearby or approaching - Stop and wait until they are at a safe distance before continuing. WARNING: Some Cutting Heads may continue to 'freewheel' for up to 40 seconds after being stopped.*
- ▲ *Never attempt to use a machine on materials in excess of its capability.*
- ▲ *Never use a machine to perform a task it has not been designed to do.*
- ▲ *Never operate the tractor or machine controls from any position other than from the driving seat, especially whilst hitching or unhitching the machine.*
- ▲ *Never carry out maintenance of a machine or a tractor whilst the engine is running – the engine should be switched off, the key removed and pocketed.*
- ▲ *Never leave a machine unattended in a raised position – it should be lowered to the ground in a safe position on a level firm site.*
- ▲ *Never leave a tractor with the key in or the engine running.*
- ▲ *Never carry out maintenance on any part or component of a machine that is raised unless that part or component has been properly substantially braced or supported.*
- ▲ *Never attempt to detect a hydraulic leak with your hand – use a piece of cardboard.*
- ▲ *Never allow children near to, or play on, a tractor or machine under any circumstances.*



## ADDITIONAL SAFETY ADVICE

### Training

Operators need to be competent and fully capable of operating this machine in a safe and efficient way prior to attempting to use it in any public place. We advise therefore that the prospective operator make use of relevant training courses available such as those run by the Agricultural Training Board, Agricultural Colleges and Dealers.

### Working in Public Places

When working in public places such as roadsides, consideration should be paid to others in the vicinity. Stop the machine immediately when pedestrians, cyclists and horse riders etc. pass. Restart only when they are at a distance that causes no risk to their safety.

### Warning Signs

It is advisable that any working area be covered by suitable warning signs and statutory in public places. Signs should be highly visible and well placed in order to give clear advanced warning of the hazard. Contact the Department of Transport or your Local Highways Authority to obtain detailed information on this subject. The latter should be contacted prior to working on the public highway advising them of the time and location of the intended work asking what is required by way of signs and procedure. – ‘Non-*authorised placement of road signs may create an offence under Highway Regulations*’.

### Use of Warning Signs

- ▲ *On two-way roads one set of signs is needed facing traffic in each direction.*
- ▲ *Work should be within 1 mile of the signs.*
- ▲ *Work only when visibility is good and at times of low risk e.g.: NOT during ‘rush-hour’.*
- ▲ *Vehicles should have an amber-flashing beacon.*
- ▲ *Ideally, vehicles should be conspicuously coloured.*
- ▲ *Debris should be removed from the road and path as soon as practicable, and at regular intervals, wearing high visibility clothing and before removing the hazard warning signs.*
- ▲ *Collect all road signs promptly when the job is completed.*

### Safety Gear

It is highly recommended that the following personal protective equipment is worn when operating and/or maintaining this machine; Coveralls, safety boots, safety glasses, hearing protection, safety helmet, protective gloves, and protective dust mask.



Although the information given here covers a wide range of safety subjects, it is impossible to predict every eventuality that can occur under differing circumstances whilst operating this machine. No advice given here can replace ‘good common sense’ and ‘total awareness’ at all times, but will go a long way towards the safe use of your McConnel machine.

## SAFETY DECALS

Safety warning decals are displayed on the machine to highlight the safety issues relating to use and maintenance of the machine. All safety decals must be kept in good readable condition and should be replaced immediately if missing or illegible. Users should make themselves aware of the meanings of the decals that are fitted to the machine and operate the machine accordingly.



**DANGER!**

Rotating components;  
Switch machine off  
& read the manual  
before maintaining.



**CAUTION!**

Keep nuts and bolts  
tight at all times.



**DANGER!**

Rotating components;  
Keep all persons at a  
safe distance from the  
working machine.



**DANGER!**

Thrown object risk;  
Keep all persons at a  
safe distance from the  
working machine.



**WARNING!**

Component inspection;  
Check rubber flaps on a regular basis – replace  
immediately if damaged, noticeably worn or missing.

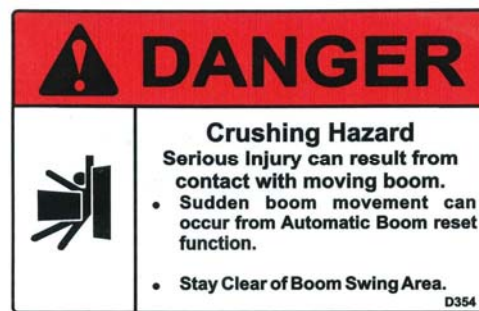

**DANGER!**

Crushing Hazard Warning.



**WARNING!**

Hydraulic Oil Safety Advice

## VEHICLE / TRACTOR PREPARATION

We recommend vehicles are fitted with cabs using 'safety glass' windows and protective guarding when used with our machines.

Fit Operator Guard (*Part No. 7313324*) using the hooks provided. Shape the mesh to cover all vulnerable areas. The driver must be looking through mesh and/or polycarbonate glazing when viewing the flail head in any working

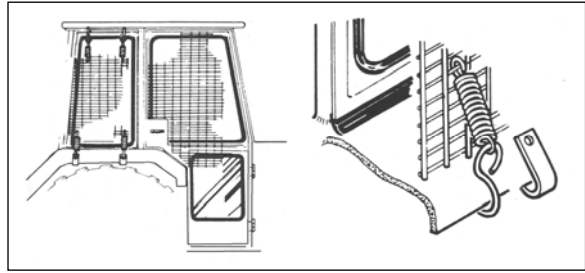

position - unless the vehicle/ cab manufacturer can demonstrate that the penetration resistance is equivalent to, or higher than, that provided by mesh/polycarbonate glazing. If the tractor has a roll bar only, a frame must be made to carry both mesh and polycarbonate glazing. The operator should also use personal protective equipment to reduce the risk of serious injury such as; eye protection (*mesh visor to EN1731 or safety glasses to EN166*), hearing protection to EN352, safety helmet to EN297, gloves, filter mask and high visibility clothing.

**Vehicle Ballast:** It is imperative when attaching 'third-party' equipment to a vehicle that the maximum possible stability of the machine and vehicle combination is achieved – this can be accomplished by the utilisation of 'ballast' in order to counter-balance the additional equipment added.

**Front weights** may be required for rear mounted machines to place 15% of total outfit weight on the front axle for stable transport on the road and to reduce 'crabbing' due to the drag of the cutting unit when working on the ground.

**Rear weights** may be required to maintain a reasonable amount of rear axle load on the opposite wheel from the arms when in work; for normal off-ground work i.e. hedge cutting this should be 20% of rear axle weight or more for adequate control, and for ground work i.e. verge mowing with experienced operators, this can be reduced to 10%.

All factors must be addressed in order to match the type and nature of the equipment added to the circumstances under which it will be used – in the instance of Power Arm Hedgecutters it must be remembered that the machines centre of gravity during work will be constantly moving and will differ from that during transport mode, therefore balance becomes critical.

### Factors that affect stability:

- *Centre of gravity of the tractor/machine combination.*
- *Geometric conditions, e.g. position of the cutting head and ballast.*
- *Weight, track width and wheelbase of the tractor.*
- *Acceleration, braking, turning and the relative position of the cutting head during these operations.*
- *Ground conditions, e.g. slope, grip, load capability of the soil/surface.*
- *Rigidity of implement mounting.*

### Suggestions to increase stability:

- *Increasing rear wheel track; a vehicle with a wider wheel track is more stable.*
- *Ballasting the wheel; it is preferable to use external weights but liquid can be added to around 75% of the tyre volume – water with anti-freeze or the heavier Calcium Chloride alternative can be used.*
- *Addition of weights – care should be taken in selecting the location of the weights to ensure they are added to a position that offers the greatest advantage.*
- *Front axle locking (check with tractor manufacturer).*

**NOTE: The advice above is offered as a guide for stability only and is not a guide to vehicle strength. It is recommended that you consult your vehicle manufacturer or local dealer to obtain specific advice on this subject, additionally advice should be sought from a tyre specialist with regard to tyre pressures and ratings suitable for the type and nature of the machine you intend to fit.**

## MACHINE ATTACHMENT

**⚠ WARNING** Attachment of this unit must always be performed on a firm level site.

Ensure all bystanders are kept at a safe distance from the machine and the tractor at all times.

### Ballasting

Depending on specific individual applications, the addition of ballast may be required to ensure the machine combination remains stable at all times during both transport and work; refer to the 'tractor / vehicle preparation' page for further information on this subject, where doubt exists, contact your local dealer or tractor specialist for advice.

### Attachment Procedure

With the machine located on a firm level site, position Power Arm's head angling mechanism adjacent to the machine's attachment bracket at the correct height and angle for connecting the two machines. Secure the machines together with the 4 nuts and bolts supplied and torque to 203 Nm (150 lb-ft.).

### Hose Connections

Connect the machine's pressure and return hoses to the pressure and return connections on the Power Arm. Certain builds feature a drain line hose; where applicable this should be plumbed into the drain line of the Power Arm. Check all hoses are correctly routed to allow them freedom to move without any risk of pinching or stretching during the normal movements of the machines. The diagrams below show the hydraulic hose connections for the different types of motors available on these machines.

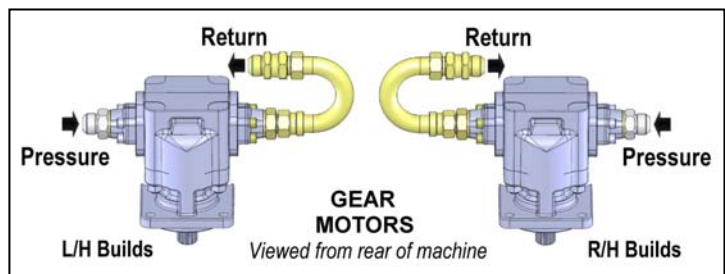
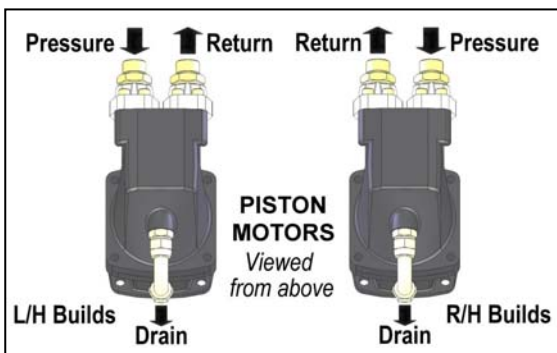
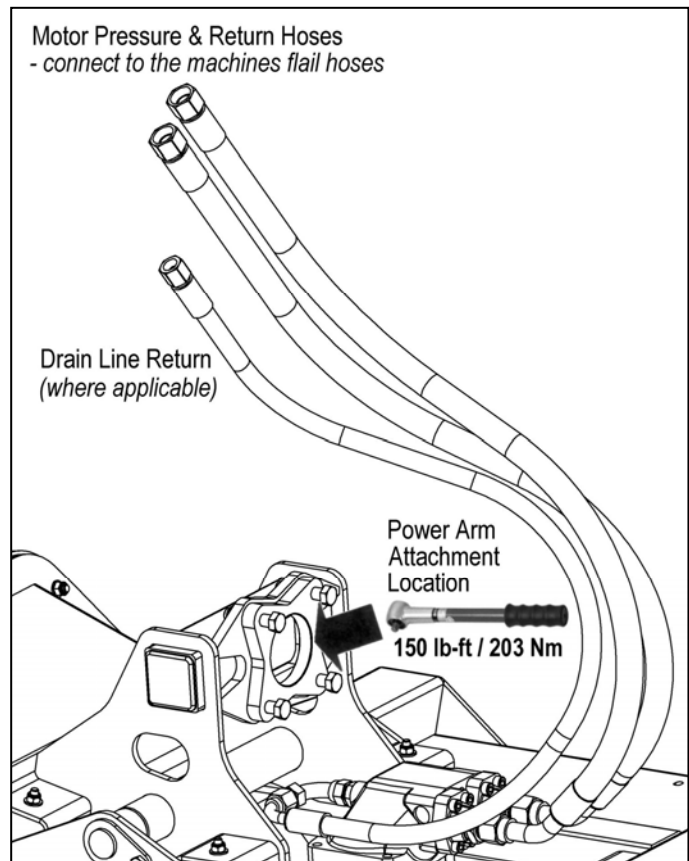

### Initial 'Run Up' Checks

With the machine correctly attached, carefully operate the Power Arm through its complete range of arm movements to ensure the unit functions correctly in all positions.

When initially starting the cutting unit, check the cutting direction of the rotor is correct; left-hand mounted machines should cut in an anti-clockwise direction and right-hand mounted machines should cut in a clockwise direction. If the cutting direction proves to be incorrect the direction should be reversed on the control unit, or alternatively, by swapping the pressure and return hose connections.



## OPERATION

### Cutting Direction – Blade Models

It is recommended that the direction of cutting should always be such that the blades are cutting away from the operator at the point where the material first enters the machine; i.e. anti-clockwise for left hand mounted machines and clockwise for right hand mounted machines (as viewed from above). Refer to the illustrations below for the correct hydraulic motor connections to produce the required cutting direction.

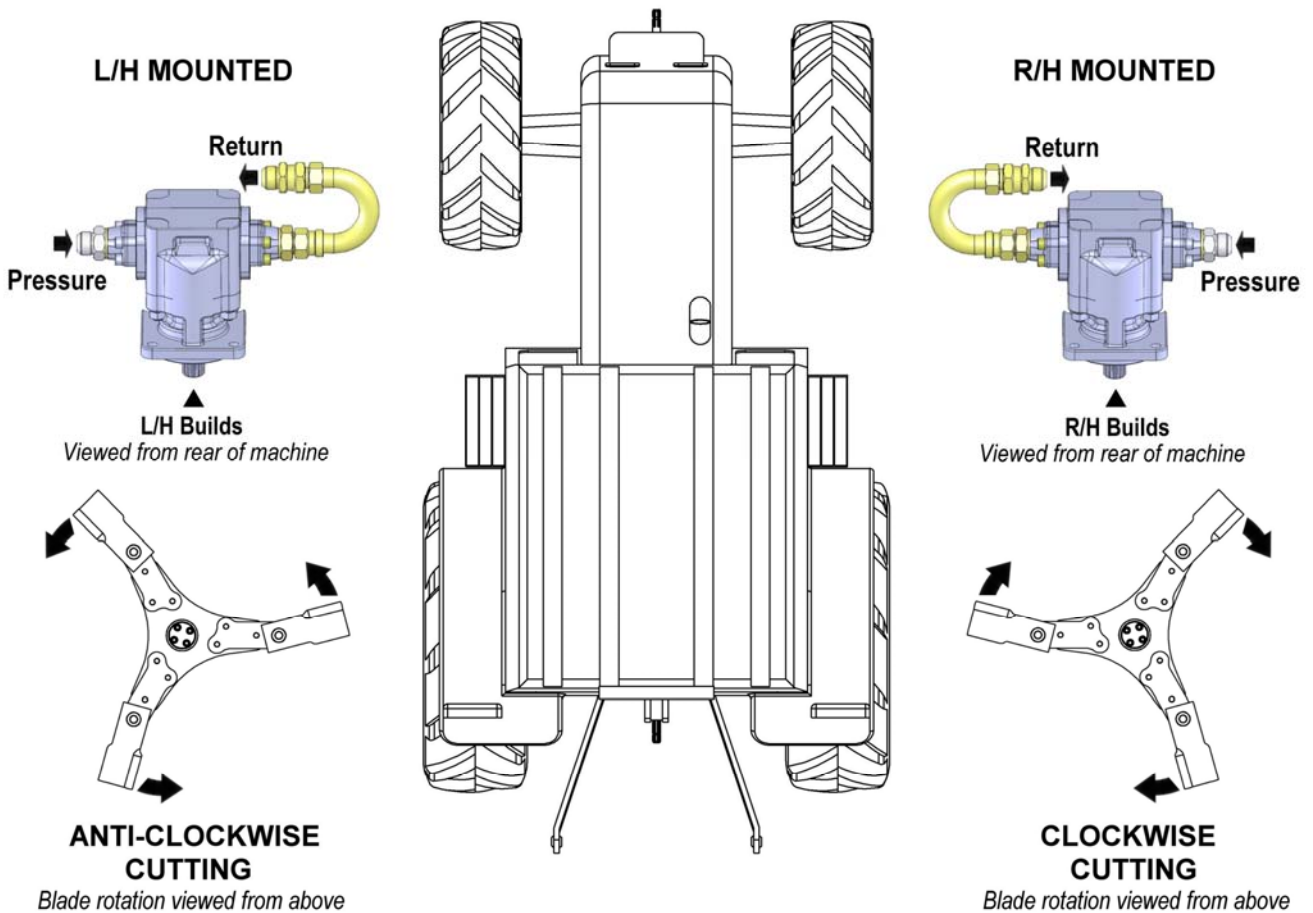

#### **CAUTION**

Never attempt to cut when moving in reverse direction; raise the head clear of the ground to avoid damage to the carrying arm.

#### **WARNING**

When rotating parts are in motion, serious injury may occur if caution is not adopted or danger is not recognized. Never allow bystanders within 300 feet of the machine when in operation. Extreme care should be taken when operating near loose objects such as gravel, rocks and debris - these conditions should always be avoided.

#### **WARNING**

The rotating parts in this machine have been designed and tested for rugged use. However, they could fail upon impact with heavy solid objects - such as steel guard rails, concrete abutments, etc., causing them to be thrown at a very high velocity. Never allow the cutter head to contact such objects; inspecting the cutting area for any dangerous objects and removing them prior to mowing will help eliminate these potential hazards. Immobile objects and/or hazards should be visibly marked so they can be easily avoided during operation.



## Cutting Direction – Chain Models

It is recommended that the direction of cutting should always be with the chains cutting away from the operator at the point where the material first enters the machine; i.e. anti-clockwise direction for left-hand mounted machines and clockwise direction for right-hand mounted machines (as viewed from above). Refer to the illustrations below for the correct hydraulic motor connections to produce the required cutting direction.

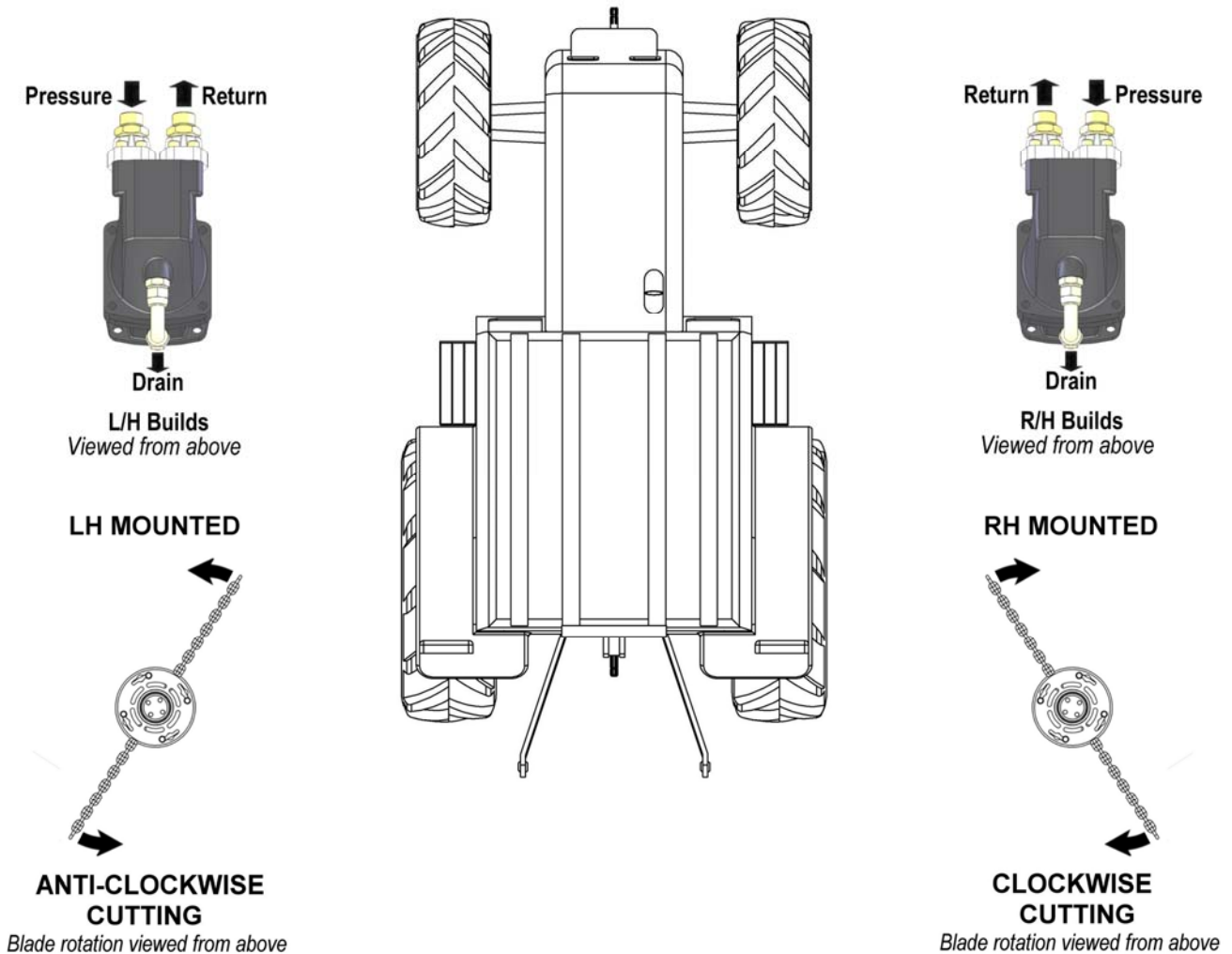

**CAUTION** Never attempt to cut when moving in reverse direction; raise the head clear of the ground to avoid damage to the carrying arm.

**WARNING** When rotating parts are in motion, serious injury may occur if caution is not adopted or danger is not recognized. Never allow bystanders within 300 feet of the machine when in operation. Extreme care should be taken when operating near loose objects such as gravel, rocks and debris - these conditions should always be avoided.

**WARNING** The rotating parts in this machine have been designed and tested for rugged use. However, they could fail upon impact with heavy solid objects - such as steel guard rails, concrete abutments, etc., causing them to be thrown at a very high velocity. Never allow the cutter head to contact such objects; inspecting the cutting area for any dangerous objects and removing them prior to mowing will help eliminate these potential hazards. Immovable objects and/or hazards should be visibly marked so they can be easily avoided during operation.

Once on location, lower the mower deck slightly above the material to be cut, so the mower does not have to start under a load. With the tractor at an idle, engage mower. Bring tractor RPM up to the correct working speed (\*) and slowly lower deck to ground level. Maintaining even speed will ensure a clean cut.

(\*) NOTE: *Working speed will be dependant on the particular machine and model that this accessory is being operated on; refer to the operation manual for that machine for details.*

When mowing on the ground, the unit should always be 'carried' rather than 'dragged' on the side skids. Dragging the unit will increase the side loads on the boom, decrease the horsepower available to the cutter head, and reduce the ability of the accumulator to carry part of the weight of the boom during mowing operations. It is recommended that it is carried in such a way that a proportion of its weight is supported by the boom of the operating machine, and a proportion carried by the side skids. When worked in this manner the skids, in association with the pivoted mounting, will allow it the freedom to follow the natural contours of the ground.

During mowing operation the correct operating speed should be maintained to prevent radical changes in mower spindle speeds, reducing risk of cutter assembly damage.

For cutting brush it is usually best to stop the tractor and swivel the boom and mower into foliage. The horizontal positioning action of the boom is designed to position the cutting head and provide a limited pressure relief when excessive pressure is applied to the boom. Never force the cutting head into heavy branches or stumps - damage to the unit may result.

**▲ CAUTION** When using the rotary cutting head for trimming trees and shrubs, let the mower 'saw' into them. Do not lower the mower head down directly onto a tree or stump. The mower blades are designed to cut with the end, any misuse can cause damage to the blade and risks placing the operator in a hazardous situation.

**▲ CAUTION** Powering the boom down, forcing mower deck onto ground may damage the deck and the boom attachment, creating a potentially hazardous situation.

**▲ CAUTION** DO NOT use excessive force when positioning cutting head into heavy branches or stumps. Damage to the unit may result. It is best to let the cutter head 'eat away' slowly at heavy cutting jobs.

**▲ CAUTION** If foliage falls on top of mower deck causing tractor to become unstable, move the boom 'Forward' and 'Out' to relieve tipping of the tractor. Lower mower deck to ground and shut down unit. After all motion stops, remove foliage from mower deck.

The mower will operate more efficiently in tougher conditions and with less power if the knives are kept sharp. If the mower begins to vibrate, stop the tractor, check for wire wrapped in the spindle or damaged knives. When replacing knives; replace all knives with new knives to ensure proper balance so the mower will not vibrate. Severe vibration will result if knives with unequal wear are used.

Begin a pass at the top side of the trees and work down with each consecutive pass. When cutting trees and shrubs; use a lower speed to allow the knives time to cut as well as mulch the foliage.

**▲ WARNING** If bystanders approach within 300 feet while mower is in operation turn the mower switch 'OFF' immediately. After shutdown, never leave the tractor or allow bystanders to approach within 300 FEET of the unit until all motion stops completely.

If cutter shaft jams and stops, turn mower switch to 'OFF', and swivel boom 'AFT'. Normally this action will clear the cutter head. If not, roll mower deck until adjacent to the secondary boom, and then lower boom to rest mower deck on ground. Shut off the tractor, set parking brake, allow all motion to cease. At that point it is safe to leave the tractor and clear the cutter heads manually.

If wires, rope or chains should become entangled in the rotor stop immediately to prevent damage or dangerous situations; stop the rotor and tractor and remove the starting key. Put working gloves on and clear the rotor with the aid of pliers or shears. Do not attempt to disentangle by inverting the rotational direction of the rotor.

Begin each pass at the top side of the trees and work down with each consecutive pass. Use a low speed to allow the cutting blades time to mulch as well as cut the foliage. When the initial pass has been made, disengage the mower, and return boom to a safe travel position. Return to starting point and make next pass, etc.

### Side Skids

The side skids have 2 mounting positions allowing the machine to cut at a height of either 2" (50mm) or 3" (75mm). Altering the cutting height is by selection of either the upper or lower skid mounting holes on the main frame; ensure that the same height position is selected on both sides of the machine. Never attempt to use the machine without skids fitted or with the skids mounted at different heights.

### Pivoted Mounting

The mounting bracket is pivoted to permit the unit deviation from the horizontal by  $\pm 4^\circ$ ; this allows the machine to follow the contours of the terrain on ground cutting work, thus providing a cleaner finish.

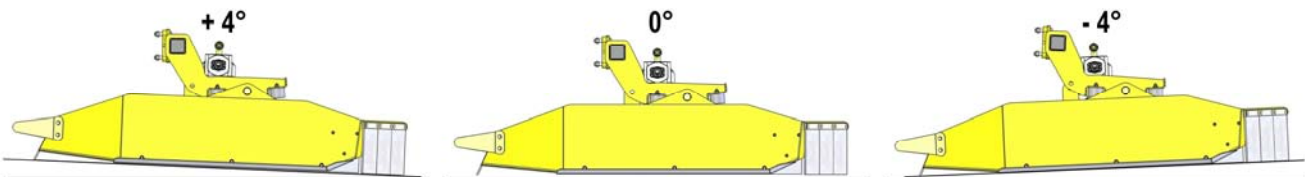

### Pivot Bracket Buffers

Rubber buffers (Part No. 1337114) are fitted to front and rear of the pivot bracket to prevent contact damage between bracket and deck when the machine pivots forwards and backwards; *these should be replaced if missing or excessively worn in order to protect machine components.*

#### NOTICE

When replacing the pivot bracket buffers it is advisable to replace front and/or rear buffers in matched pairs; this will retain even pressure on each side of the pivot bracket when it is in contact with the deck.

Buffers should be replaced at least every 2 years to ensure their damping properties are retained.

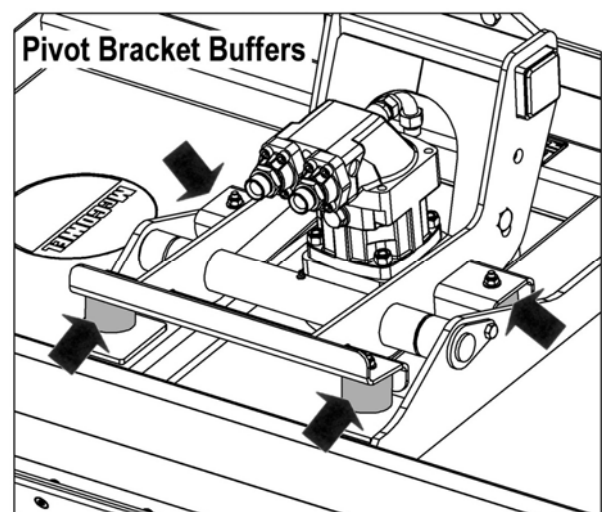

### Blade Nut Access Point (Blade Models only)

A removable cover is located on the deck of the machine to allow access to the blade bolt nut. If removed for service or maintenance work always ensure it is correctly replaced before using the machine.

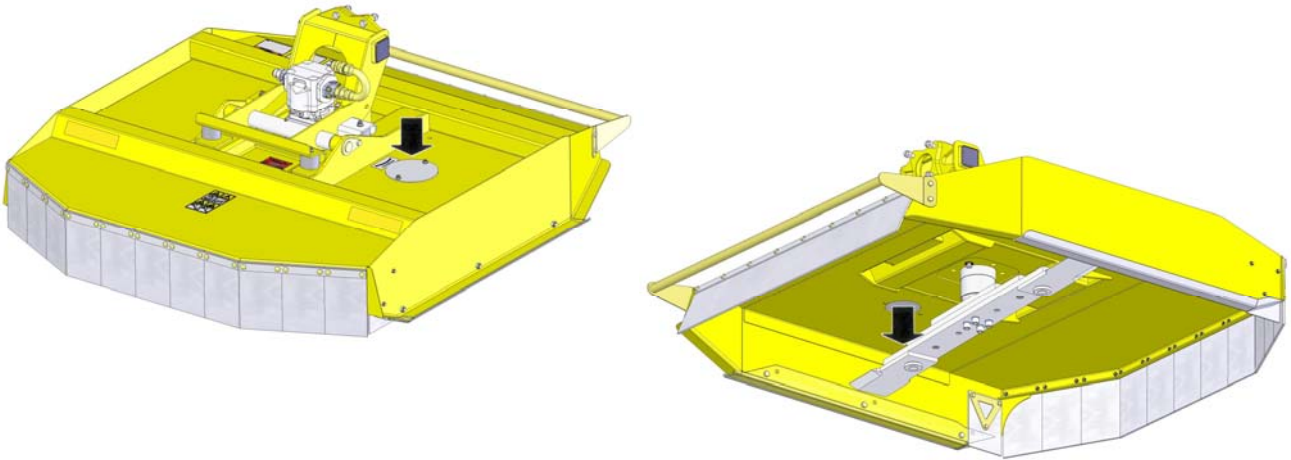

### Safety Protection

Machines are equipped with heavy duty rubber guarding, front and rear, for protection against cut materials, or dangerous objects such as stones, from being ejected out of the machine at high speed. These guards must be fitted to the machine at all times for work.

*The following illustrations show the rubber safety guards that are fitted to these machines.*

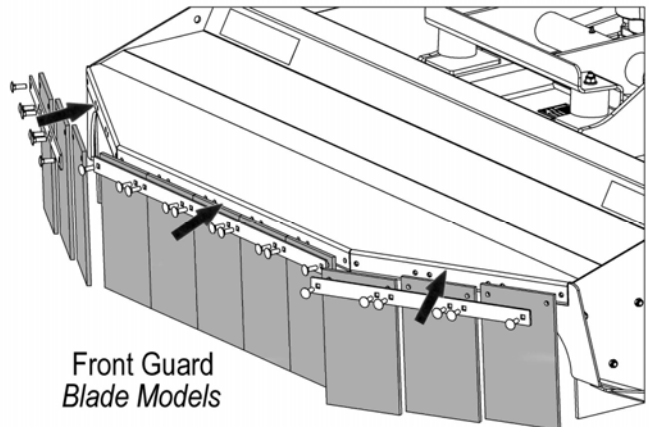
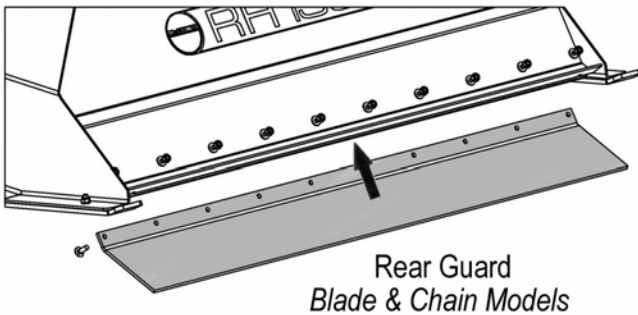

### **⚠ WARNING**

Rubber guards must be replaced immediately as soon as they become excessively worn and/or damaged or when they fail to perform their designed function correctly or efficiently.

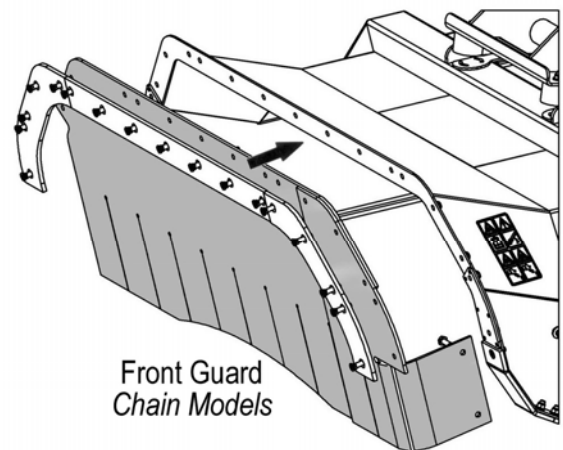



## Deck Stop

A Stop assembly is provided for placement on the connecting boom of the operating machine; it is multi-adjustable for use on 100mm square section or 100/110mm tapered section booms.

Its function is primarily to stop the deck coming into contact with the machines arm components when the head is fully angled, but also acts as a support for the unit during transportation.

The stop should be assembled to the required configuration to fit the specific boom and positioned on the boom at a height where the rubber buffers contact an outer point on the top of the deck when the unit is fully angled in either direction.

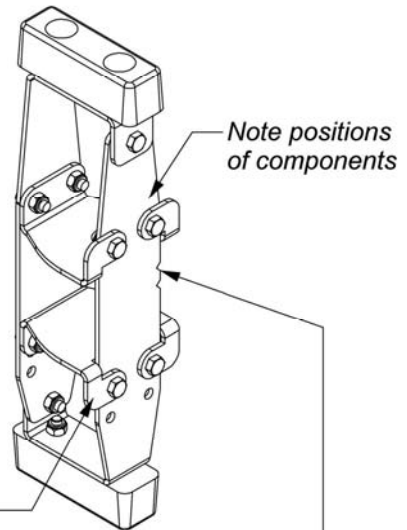

*Note positions of components*

*Note positions of components*

ASSEMBLED FOR:  
100MM SQUARE ARM SECTION

### ASSEMBLY NOTE:

*The notches should be nearest to the top of the dipper arm and facing towards the head pivot tube.*

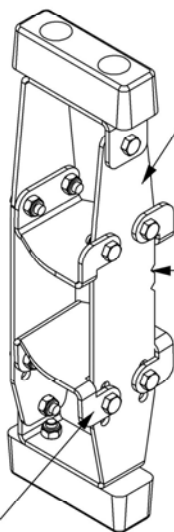

*Note positions of components*

*Note positions of components*

ASSEMBLED FOR:  
100MM WIDE TAPERED ARM SECTION

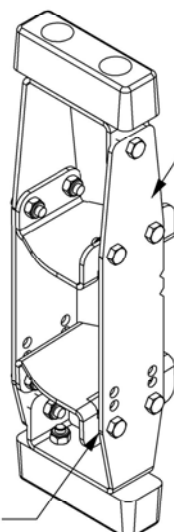

*Note positions of components*

*Note positions of components*

ASSEMBLED FOR:  
110MM WIDE TAPERED ARM SECTION

## OPERATING WITH LIFT FLOAT KIT

### Lift Float Preparation

For lift float operation pivot bolts must be removed from both sides of the pivot assembly.

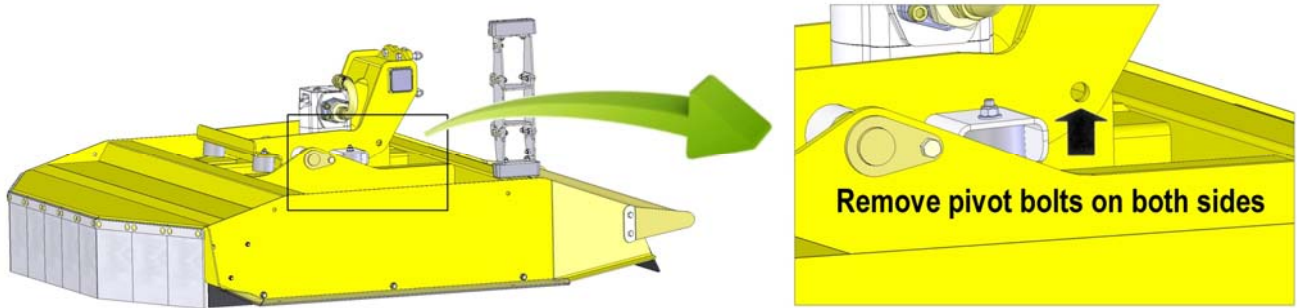

### To Test Operation

Set the height of the skids to the required approximate cut height above ground level.

From the operating position in the tractor cab, extend the machines arm fully and place the cutting head on the ground.

Activate the float - *this can be done either manually or with the switch kit option.*

Operate lift up - *it is normally for there to be an initial delay as the oil fills the float bottle first before transferring to the ram.*

Return lift control to the neutral when the cutting head lifts off the ground. **Caution! the arm may continue to lift for a few seconds.**

It will be noticed that lift operation is now spongy.

Gently operate 'lift down' and stop when the skids touch the ground.

### During Operation

The weight carried on the skids is now controlled by the amount of oil trapped in the lift circuit. The lighter the load on the skids the less they will wear; therefore their working life will be extended. Adding oil (lift up) will make the load on the skids lighter, removing oil (lift down) will make the load on the skids heavier.

Adjust the amount of oil when the ground height of the work changes relative to the tractor and /or when altering the working distance of the cutting head to the tractor. Continual adjustment will be required on uneven or undulating terrain.



**CAUTION!** the cutting head will still be need to be lifted over objects and in places where the ground is raised between the skids; there may be some delay on lift so extra care and reduced forward speed should be adopted.

### After Operation

Place the cutting head fully on the ground to release the trapped pressure from the float circuit, switch off the floats to revert to normal arm operation for work and/or transport.



**DANGER!** Never loosen lift connections with pressure trapped in the lift circuit.  
**DANGER!** Float should not be used in transport.



**CAUTION!** The work area should be inspected prior to work and all hazardous objects removed or suitably marked so that they can be avoided during operations.



## TRANSPORTATION

---

### **Transport Position**

When transporting between job sites, or between cutting passes, the following procedure should be followed; shut off the power to the cutting head and allow all motion to come to a complete stop. Raise the boom to its highest position taking care to avoid all overhead obstructions such as power cables, trees etc. Rotate the deck to a position where it contacts the stop buffer before then folding the arms of the machine into a position where it is as compact as possible. Fit and secure any transport locks and close the lift ram tap if applicable.

Check before transporting that the unit has ample clearance from the tractor tyres and other tractor or machine components. The unit is now in position for transportation.

### **Transport Speed**

Transport speeds should be kept to a minimum on uneven terrain, and in all conditions avoid driving at a speed which causes exaggerated bouncing as this will put unnecessary strain on the tractors top hitch position.

## MAINTENANCE

---

Maintenance duties on the machine have been kept to a minimum; daily maintenance comprises of checking tightness of fixings and a full inspection of machine components for signs of wear and damage prior to work.

Components showing signs of excessive wear and/or damage that are dangerous to persons or damaging to the machine must be replaced immediately before attempting to use the machine. *Refer to operation section for details of rubber flaps, rubber buffers and skids.*

Greasing of the lubrication point on the pivot should be performed on a daily basis; seals are fitted on the pivot to restrict the entry of dust or grit, but will allow the discharge of excess grease.

Checks of the oil level in the bearing housing should be made on a regular basis; top up to the plug level, as and when required, using EP90 gearbox oil. An indication that an oil top up may be required is signs of oil weeping onto the lower bearing unit beneath the deck; if the amount of oil weeping is excessive the bearing seals will need replacing. The oil capacity is 560ml (18.9 US fl.oz.).

After work with the machine it should always be cleaned to remove dirt and debris.

### Pivot Bracket Lubrication

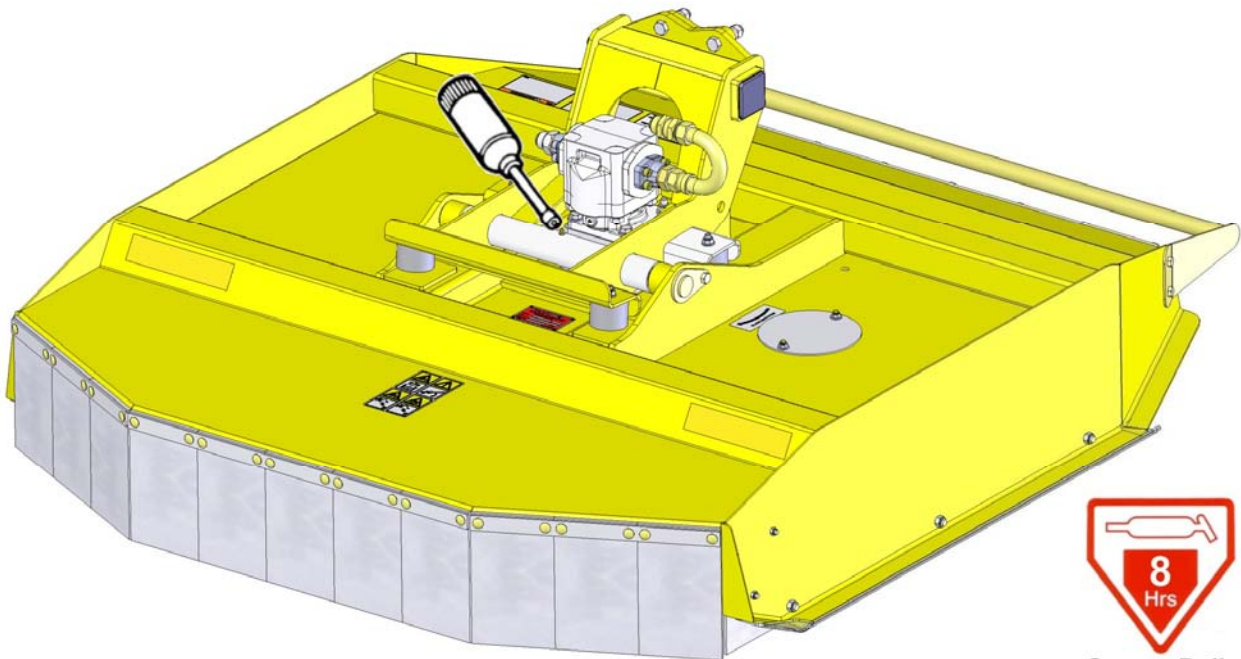

**Grease Daily**

### Machine Storage

Prior to storage the machine should be thoroughly cleaned to remove dirt and debris. Avoid using high pressure power washers as these can cause damage to paintwork.

Grease the point indicated above prior to storage. Wherever possible the machine should be stored in a clean dry location where it is protected from the elements.

Ensure the machine is stored on a firm level site and is left in a safe stable condition.

## Blade Bar Torque Settings

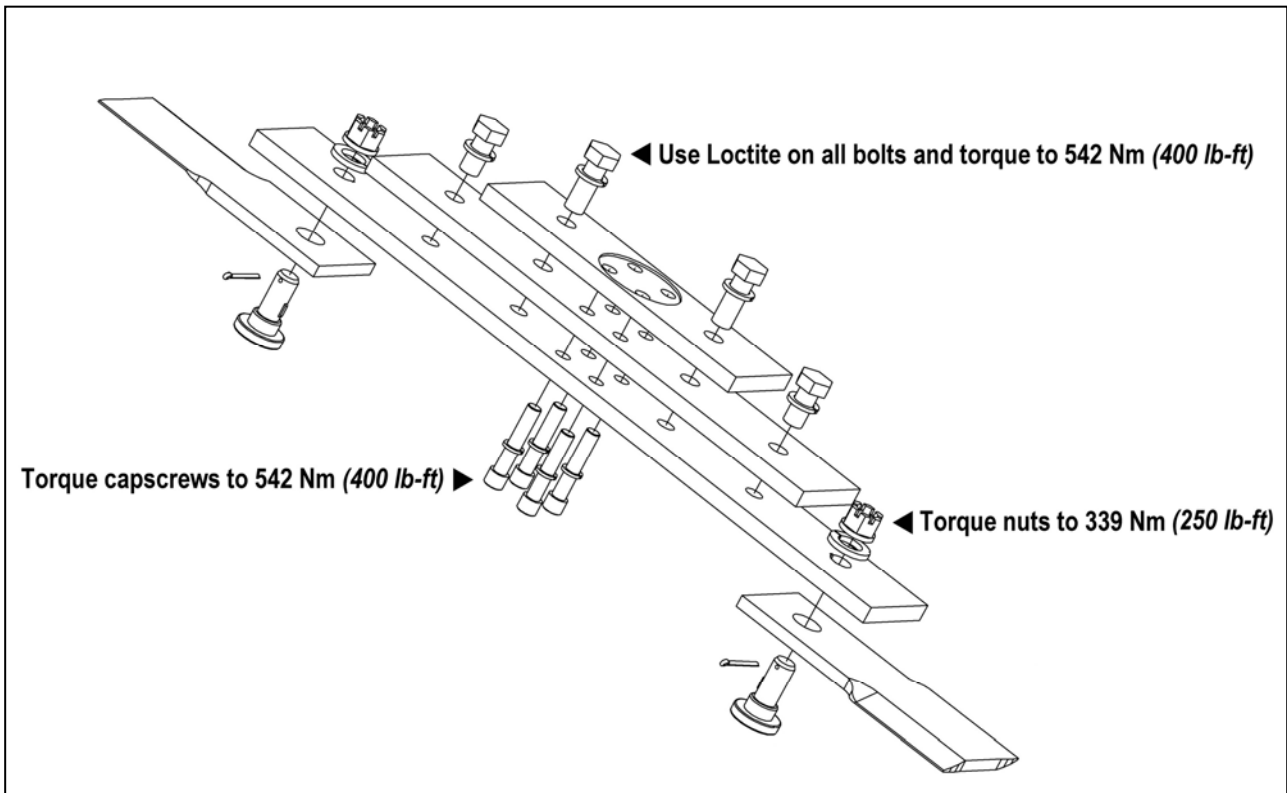

## Chain Hub & Bearing Unit Torque Settings

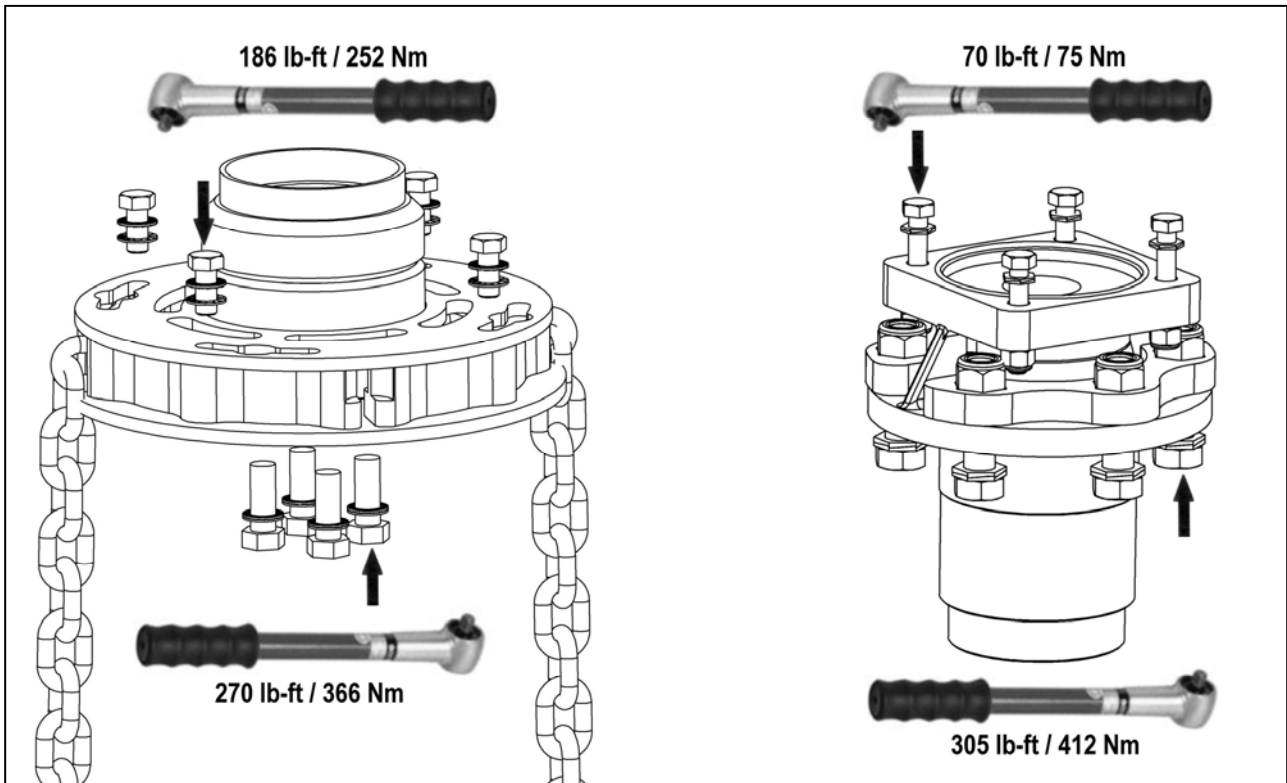

## Cutting Chains & Chain Hub

Machines can be used with a choice of 2 chain sizes; 10mm or 13mm.

The chain hub is designed to accept either 10mm or 13mm chain sets. Chain sets are installed diagonally opposite each other selecting the correct slots for the size of chain. Chain sets must always be matching in diameter and length.

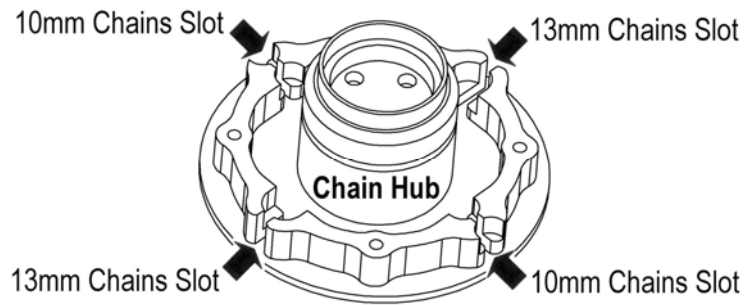

### NOTICE

Take care not to fit the 10mm chains in the 13mm chain slots of the hub.

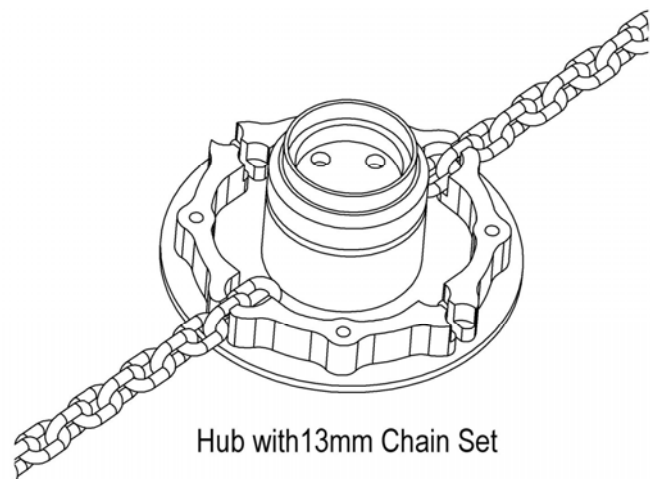
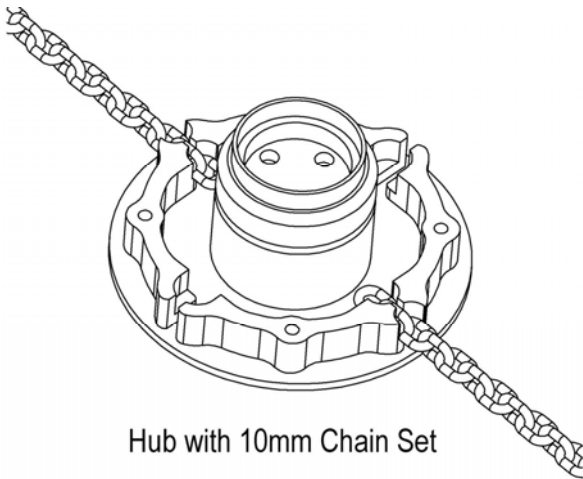

## Chains Inspection

### ⚠ WARNING

Ensure both machine and tractor are switched off and the starting key removed before attempting to inspect the cutting unit.

Cutting chains should be inspected for signs of excessive wear or damage on a regular basis and always prior to operation; end links of the chain sets that have worn to 8mm for 10mm chain sets or 10mm for 13mm chain sets should be removed immediately. Chain sets that are severely damaged or have been weakened due to an accidental collision with a hard or fixed object should be replaced before using the machine.

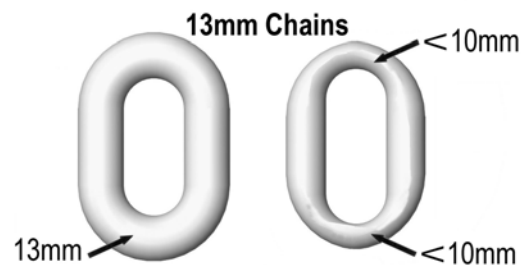
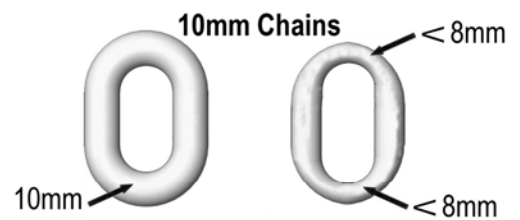
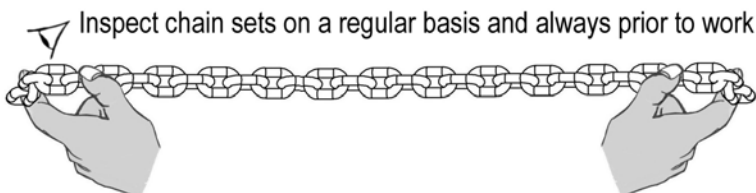

Remove end links if worn to figures stated

## Chain Link Removal

Worn outer links of the chain sets can be removed using an angle grinder or bolt cutters; when removing links make sure the working length of the chain sets remain equal, this will ensure the rotor is balanced.

Chain sets are supplied with additional links attached to allow the chain sets to be adjusted outwards when outer end links have been removed; this ensures the machine retains its maximum cutting width. When fitting new chains there is sufficient space within the hub to stow the additional length of chain.

## Chain Set Removal & Replacement

Park the machine on a firm level site when performing servicing and maintenance duties.

### **⚠ WARNING**

Ensure the machine is suitably and safely supported before attempting to access areas beneath the machine.

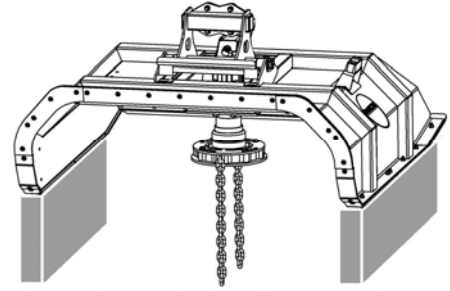

### Chain Set Removal

Loosen the 4 bolts on chain hub cover plate

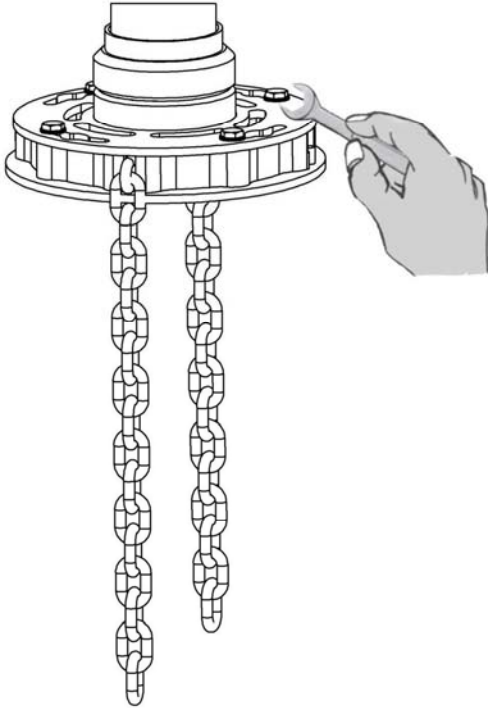

Rotate cover plate to align slots with bolt heads  
*LH Models A/CW*                      *RH Models CW*

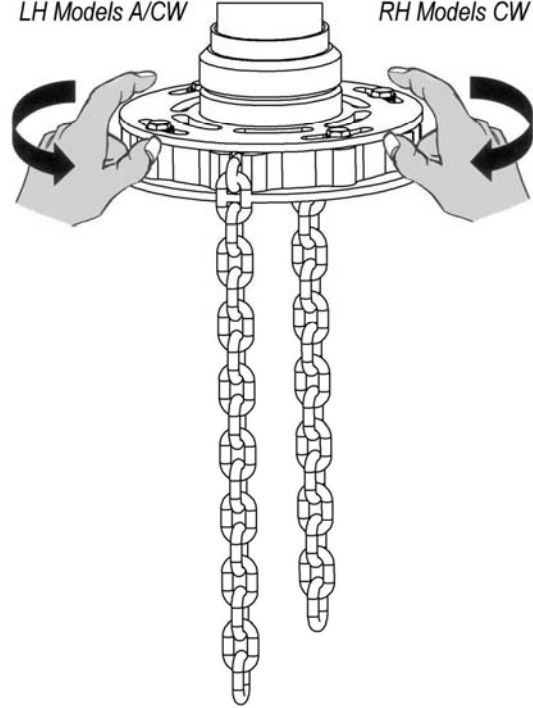

Lift cover off bolts to allow access to inner hub

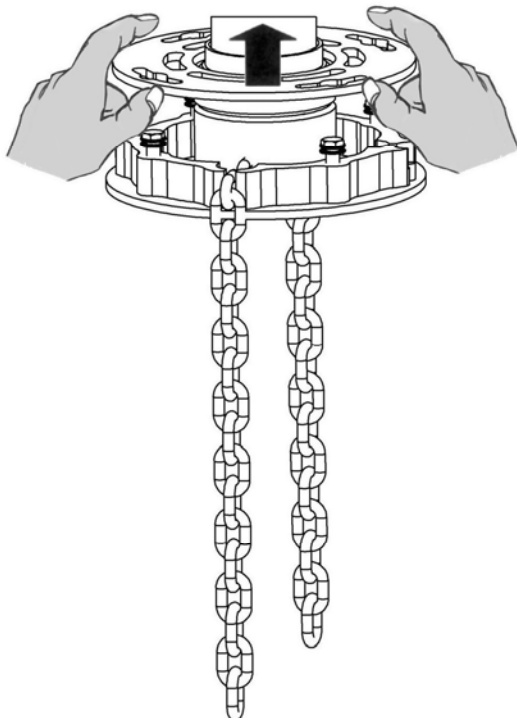

Remove chain sets from hub slots

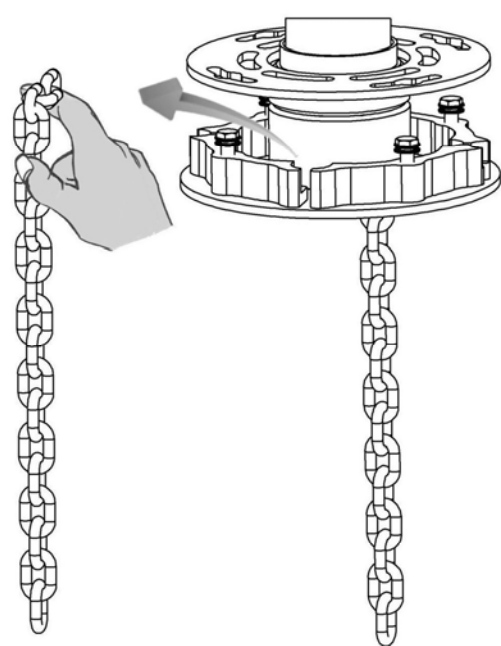



## Chain Set Replacement



**WARNING**

Check hub and slots for wear and/or damage whilst chains are removed.



**WARNING**

Never attempt to use chains other than the sizes specified.



**WARNING**

Never attempt to fit and use un-matched sets of chains.



**WARNING**

Never attempt to fit chains with worn links fitted to the hub.

Seat the chain sets in their specific size hub slots

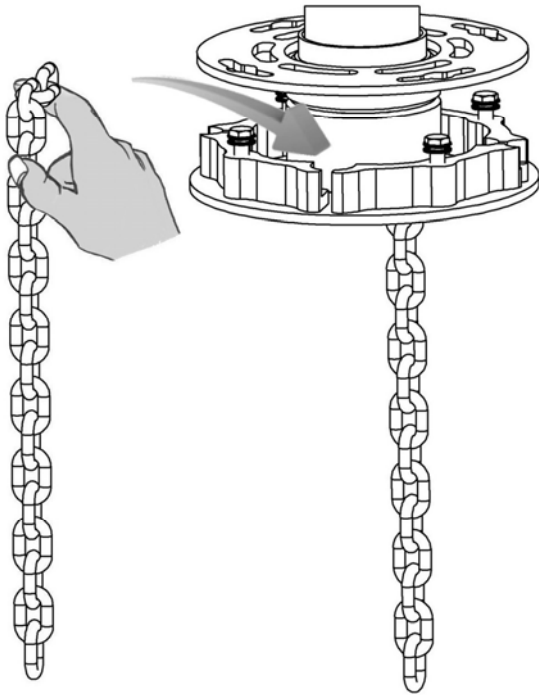

Ensure the same number of links are outside of the hub on each set and the maximum number of links are not exceeded

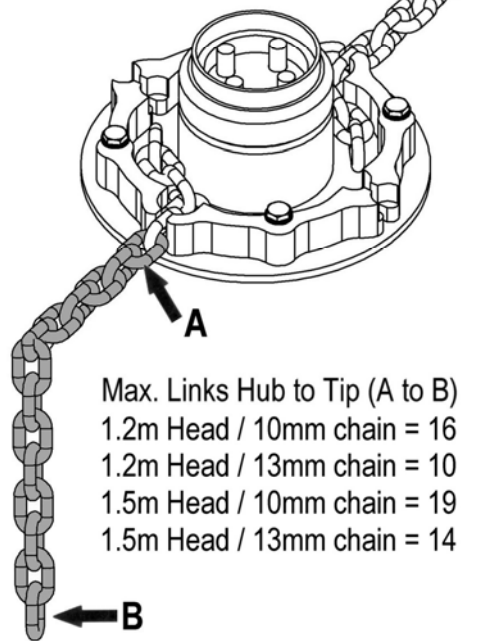

Max. Links Hub to Tip (A to B)  
 1.2m Head / 10mm chain = 16  
 1.2m Head / 13mm chain = 10  
 1.5m Head / 10mm chain = 19  
 1.5m Head / 13mm chain = 14

Align cover with bolts and lower into position

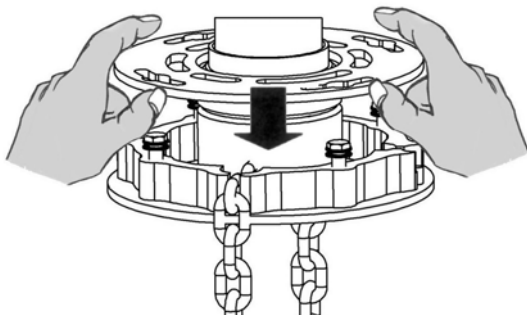

Rotate cover to engage with the bolts

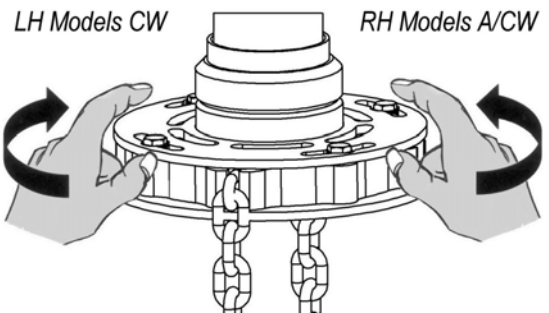

Tighten all 4 bolts evenly

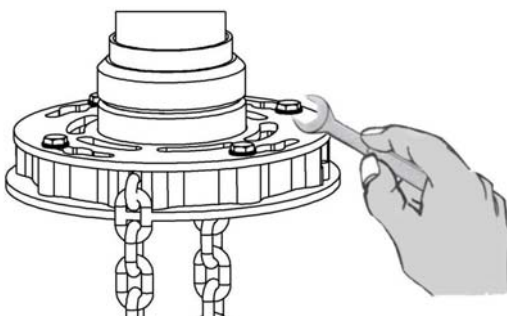

Torque to 252 Nm.

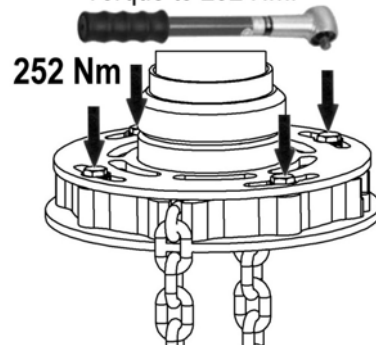

**CAUTION**

Check the chain sets to ensure they are of equal length and do not touch the casing of the machine when they are outwardly extended.



## Chain Hub Wear

At regular intervals the chain hub should be thoroughly inspected for signs of damage or excessive wear; this will require removal of the chain sets in order to check the critical areas in and around the chain slots.

No set time limit can be quoted for the frequency of these thorough inspections as levels of wear will vary depending on the nature and intensity of work undertaken, but frequent checks are advisable and therefore recommended.

The chain hub must always be replaced immediately if signs of damage are found or if any areas of the hub are worn to the critical limits indicated below.

### Specified Dimensions

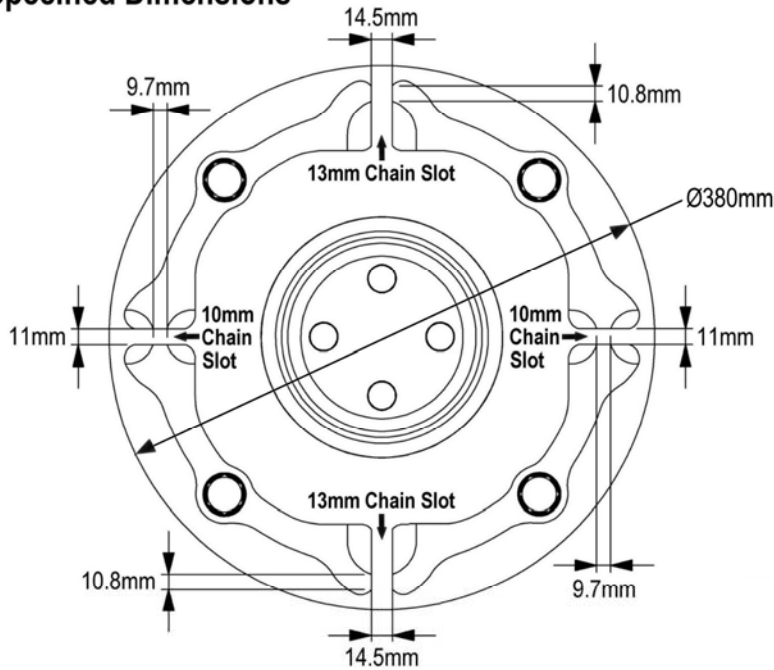

### Specified Shoulder Profile

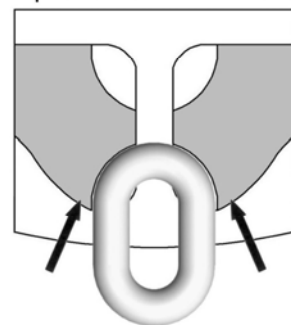

### Critical Wear Areas

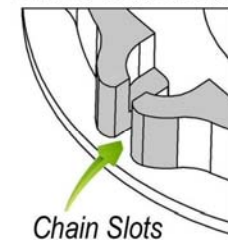

### Critical Wear Limits

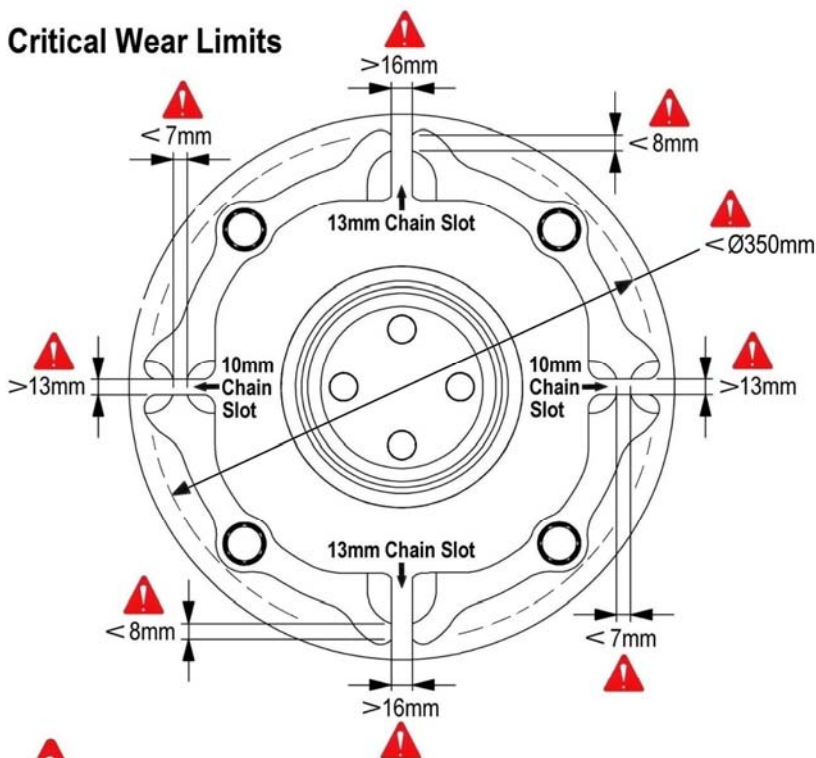

### Shoulder Max. Wear Limit

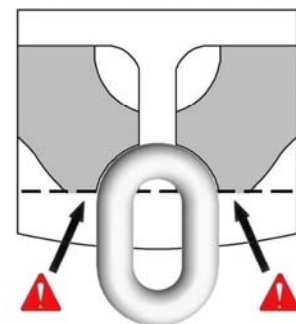

Chain hub must be replaced when any of the limits indicated are reached or exceeded.

## WARNING

Should the machine accidentally strike a fixed or heavy solid object; switch off machine and thoroughly inspect chains and hub for damage.

# TORQUE SETTINGS FOR FASTENERS

The Chart below lists the correct tightening torque for fasteners. The Chart should be referred to when tightening or replacing bolts in order to determine the grade of bolt and the correct torque unless specific torque values are assigned in the text of the manual.

*Recommended torque is quoted in Foot-Pounds and Newton-Metres within this manual.  
The equation for conversion is 1 Nm. = 1.356 ft. lbs.*

## TORQUE VALUES FOR IMPERIAL BOLTS

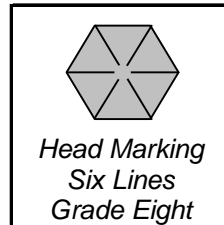
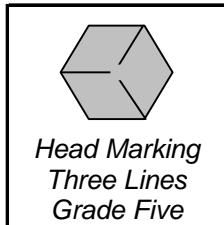
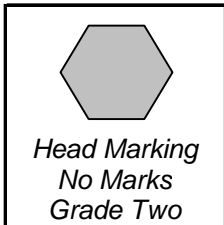

**NOTE:**  
The values in the chart apply to fasteners as received from the supplier, dry or when lubricated with normal engine oil. They **DO NOT** apply if special graphited, molydisulphide greases, or other extreme pressure lubricants are used. This applies to both UNF and UNC coarse threads.

Bolt Dia.
1/4"
5/16"
3/8"
7/16"
1/2"
9/16"
5/8"
3/4"
7/8"
1"
1-1/8"
1-1/4"
1-3/8"
1-1/2"

Value (Dry)	
ft.lb.	Nm.
5.5	7.5
11	15.0
20	27.0
32	43.0
50	68.0
70	95.0
100	135.0
175	240.0
175	240.0
270	360.0
375	510.0
530	720.0
700	950.0
930	1250.0

Value (Dry)	
ft.lb.	Nm.
9	12.2
18	25.0
33	45.0
52	70.0
80	110.0
115	155.0
160	220.0
280	380.0
450	610.0
675	915.0
850	115.0
1200	1626.0
1550	2100.0
2100	2850.0

Value (Dry)	
ft.lb.	Nm.
12.5	17.0
26	35.2
46	63.0
75	100.0
115	155.0
160	220.0
225	305.0
400	540.0
650	880.0
975	1325.0
1350	1830.0
1950	2650.0
2550	3460.0
3350	4550.0

## TORQUE VALUES FOR METRIC BOLTS.

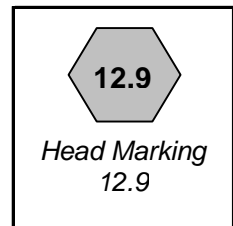
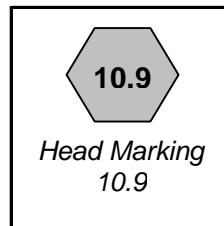
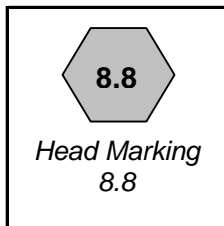
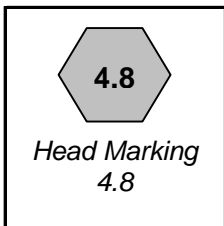

Bolt Dia.
6mm
8mm
10mm
12mm
14mm
16mm
18mm
20mm
22mm
24mm
27mm
30mm

Value (Dry)	
ft.lb.	Nm.
4.5	6.1
11	14.9
21	28.5
37	50.2
60	81.4
92	125.0
125	170.0
180	245.0
250	340.0
310	420.0
450	610.0
625	850.0

Value (Dry)	
ft.lb.	Nm.
8.5	11.5
20	27.1
40	54.2
70	95.0
110	150.0
175	240.0
250	340.0
350	475.0
475	645.0
600	810.0
875	1180.0
1200	1626.0

Value (Dry)	
ft.lb.	Nm.
12	16.3
30	40.1
60	81.4
105	140.0
165	225.0
255	350.0
350	475.0
500	675.0
675	915.0
850	1150.0
1250	1700.0
1700	2300.0

Value (Dry)	
ft.lb.	Nm.
14.5	20.0
35	47.5
70	95.0
120	160.0
190	260.0
300	400.0
410	550.0
580	790.0
800	1090.0
1000	1350.0
1500	2000.0
2000	2700.0







McConnel Limited, Temeside Works, Ludlow, Shropshire SY8 1JL. England.  
Telephone: 01584 873131. Facsimile: 01584 876463. [www.mcconnel.com](http://www.mcconnel.com)