

Publication 703
February 2012
Part No. 22675.03
Revised: 08.09.22



PA ECO Series

5055 / 5555 / 6055

HEDGE CUTTER / GRASS MOWER

Operator Manual



IMPORTANT

VERIFICATION OF WARRANTY REGISTRATION



Dealer Warranty Information & Registration Verification

It is imperative that the selling dealer registers this machine with McConnel Limited before delivery to the end user – failure to do so may affect the validity of the machine warranty.

To register machines; log onto <https://my.mcconnel.com> and select 'Machine Registration' which can be found in the 'Warranty' section of the site. **Confirm to the customer that the machine has been registered by completing the verification form below.**

Registration Verification	Serial No. <input type="text"/>
Dealer Name:	
Dealer Address:	
Customer Name:	
Date of Warranty Registration:/...../.....	Dealer Signature:

Note to Customer / Owner

Please ensure the section above has been completed and signed by the dealer to verify your machine has been registered with McConnel Limited.

IMPORTANT: During the initial 'bedding in' period of a new machine it is the customer's responsibility to regularly inspect all nuts, bolts and hose connections for tightness and re-tighten if required. New hydraulic connections occasionally weep small amounts of oil as the seals and joints settle in – where this occurs it can be cured by re-tightening the connection – *refer to torque settings chart below*. The tasks stated above should be performed on an hourly basis during the first day of work and at least daily thereafter as part of the machine's general maintenance procedure.

CAUTION: DO NOT OVER TORQUE HYDRAULIC FITTINGS AND HOSES

Torque Settings for Hydraulic Fittings

Hydraulic Hose Ends		
BSP	Setting	Metric
1/4"	18 Nm	19 mm
3/8"	31 Nm	22 mm
1/2"	49 Nm	27 mm
5/8"	60 Nm	30 mm
3/4"	80 Nm	32 mm
1"	125 Nm	41 mm
1.1/4"	190 Nm	50 mm
1.1/2"	250 Nm	55 mm
2"	420 Nm	70 mm

Port Adaptors with Bonded Seals		
BSP	Setting	Metric
1/4"	34 Nm	19 mm
3/8"	47 Nm	22 mm
1/2"	102 Nm	27 mm
5/8"	122 Nm	30 mm
3/4"	149 Nm	32 mm
1"	203 Nm	41 mm
1.1/4"	305 Nm	50 mm
1.1/2"	305 Nm	55 mm
2"	400 Nm	70 mm

WARRANTY POLICY

WARRANTY REGISTRATION

All machines must be registered, by the selling dealer with McConnel Ltd, before delivery to the end user. On receipt of the goods it is the buyer's responsibility to check that the Verification of Warranty Registration in the Operator's Manual has been completed by the selling dealer.

1. LIMITED WARRANTIES

- 1.01. *All mounted machines supplied by McConnel Ltd are warranted to be free from defects in material and workmanship from the date of sale to the original purchaser for a period of 12 months, unless a different period is specified.
All Self Propelled Machines supplied by McConnel Ltd are warranted to be free from defects in material and workmanship from the date of sale to the original purchaser for a period of 12 months or 1500 hours. Engine warranty will be specific to the Manufacturer of that unit.*
- 1.02. *All spare parts supplied by McConnel Ltd and purchased by the end user are warranted to be free from defects in material and workmanship from the date of sale to the original purchaser for a period of 6 months. All parts warranty claims must be supported by a copy of the failed part invoice to the end user. We cannot consider claims for which sales invoices are not available.*
- 1.03. *The warranty offered by McConnel Ltd is limited to the making good by repair or replacement for the purchaser any part or parts found, upon examination at its factory, to be defective under normal use and service due to defects in material or workmanship. Returned parts must be complete and unexamined. Pack the component(s) carefully so that any transit damage is avoided. All ports on hydraulic items should be drained of oil and securely plugged to prevent seepage and foreign body ingress. Certain other components, electrical items for example, may require particular care when packing to avoid damage in transit.*
- 1.04. *This warranty does not extend to any product from which McConnel Ltd's serial number plate has been removed or altered.*
- 1.05. *The warranty policy is valid for machines registered in line with the terms and conditions detailed and on the basis that the machines do not extend a period of 24 months or greater since their original purchase date, that is the original invoice date from McConnel Limited.
Machines that are held in stock for more than 24 months cannot be registered for warranty.*
- 1.06. *This warranty does not apply to any part of the goods, which has been subjected to improper or abnormal use, negligence, alteration, modification, fitment of non-genuine parts, accident damage, or damage resulting from contact with overhead power lines, damage caused by foreign objects (e.g. stones, iron, material other than vegetation), failure due to lack of maintenance, use of incorrect oil or lubricants, contamination of the oil, or which has served its normal life. This warranty does not apply to any expendable items such as blades, belts, clutch linings, filter elements, flails, flap kits, skids, soil engaging parts, shields, guards, wear pads, pneumatic tyres or tracks.*
- 1.07. *Temporary repairs and consequential loss - i.e. oil, downtime and associated parts are specifically excluded from the warranty.*
- 1.08. *Warranty on hoses is limited to 12 months and does not include hoses which have suffered external damage. Only complete hoses may be returned under warranty, any which have been cut or repaired will be rejected.*
- 1.09. *Machines must be repaired immediately a problem arises. Continued use of the machine after a problem has occurred can result in further component failures, for which McConnel Ltd cannot be held liable, and may have safety implications.*
- 1.10. *If in exceptional circumstances a non McConnel Ltd part is used to effect a repair, warranty reimbursement will be at no more than McConnel Ltd's standard dealer cost for the genuine part.*

- 1.11. *Except as provided herein, no employee, agent, dealer or other person is authorised to give any warranties of any nature on behalf of McConnell Ltd.*
- 1.12. *For machine warranty periods in excess of 12 months the following additional exclusions shall apply:*
 - 1.12.1. *Hoses, exposed pipes and hydraulic tank breathers.*
 - 1.12.2. *Filters.*
 - 1.12.3. *Rubber mountings.*
 - 1.12.4. *External electric wiring.*
 - 1.12.5. *Bearings and seals*
 - 1.12.6. *External Cables, Linkages*
 - 1.12.7. *Loose/Corroded Connections, Light Units, LED's*
 - 1.12.8. *Comfort items such as Operator Seat, Ventilation, Audio Equipment*
- 1.13. *All service work, particularly filter changes, must be carried out in accordance with the manufacturer's service schedule. Failure to comply will invalidate the warranty. In the event of a claim, proof of the service work being carried out may be required.*
- 1.14. *Repeat or additional repairs resulting from incorrect diagnosis or poor quality previous repair work are excluded from warranty.*

NB Warranty cover will be invalid if any non-genuine parts have been fitted or used. Use of non-genuine parts may seriously affect the machine's performance and safety. McConnell Ltd cannot be held responsible for any failures or safety implications that arise due to the use of non-genuine parts.

2. REMEDIES AND PROCEDURES

- 2.01. *The warranty is not effective unless the Selling Dealer registers the machine, via the McConnell web site and confirms the registration to the purchaser by completing the confirmation form in the operator's manual.*
- 2.02. *Any fault must be reported to an authorised McConnell Ltd dealer as soon as it occurs. Continued use of a machine, after a fault has occurred, can result in further component failure for which McConnell Ltd cannot be held liable.*
- 2.03. *Repairs should be undertaken within two days of the failure. Claims submitted for repairs undertaken more than 2 weeks after a failure has occurred, or 2 days after the parts were supplied will be rejected, unless the delay has been authorised by McConnell Ltd. Please note that failure by the customer to release the machine for repair will not be accepted as a reason for delay in repair or submitting warranty claims.*
- 2.04. *All claims must be submitted, by an authorised McConnell Ltd Service Dealer, within 30 days of the date of repair.*
- 2.05. *Following examination of the claim and parts, McConnell Ltd will pay, at their discretion, for any valid claim the invoiced cost of any parts supplied by McConnell Ltd and appropriate labour and mileage allowances if applicable.*
- 2.06. *The submission of a claim is not a guarantee of payment.*
- 2.07. *Any decision reached by McConnell Ltd. is final.*

3. LIMITATION OF LIABILITY

- 3.01. *McConnell Ltd disclaims any express (except as set forth herein) and implied warranties with respect to the goods including, but not limited to, merchantability and fitness for a particular purpose.*
- 3.02. *McConnell Ltd makes no warranty as to the design, capability, capacity or suitability for use of the goods.*
- 3.03. *Except as provided herein, McConnell Ltd shall have no liability or responsibility to the purchaser or any other person or entity with respect to any liability, loss, or damage caused or alleged to be caused directly or indirectly by the goods including, but not limited to, any indirect, special, consequential, or incidental damages resulting from the use or operation of the goods or any breach of this warranty. Notwithstanding the above limitations and warranties, the manufacturer's liability hereunder for damages incurred by the purchaser or others shall not exceed the price of the goods.*
- 3.04. *No action arising out of any claimed breach of this warranty or transactions under this warranty may be brought more than one (1) year after the cause of the action has occurred.*

4. MISCELLANEOUS

- 4.01. McConnel Ltd may waive compliance with any of the terms of this limited warranty, but no waiver of any terms shall be deemed to be a waiver of any other term.*
- 4.02. If any provision of this limited warranty shall violate any applicable law and is held to be unenforceable, then the invalidity of such provision shall not invalidate any other provisions herein.*
- 4.03. Applicable law may provide rights and benefits to the purchaser in addition to those provided herein.*

McConnel Limited

POWER ARM & TRACTOR PRE-OPERATION INSPECTION

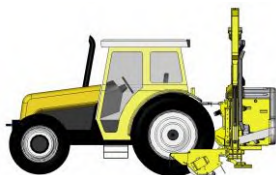

A daily equipment inspection of machine and tractor should be conducted before the equipment is used.

Use the inspection sheets on the following pages to assist with these daily inspections. Damaged or missing guards should be repaired or replaced before operating the mower. Failure to repair or replace damaged guards can result in objects being thrown from the mower and possibly hitting the operator and/or bystanders.

Inspect the Mower for Safe Operating Condition

- Make sure the driveline guards and shielding are in place and in good repair.
- Inspect the flexible thrown object shielding to assure that they are in place on the front and rear of the mower head and in good repair. Repair or replace any damaged or missing thrown object shields.
- Ensure the mower cutting height is set high enough to reduce the possibility of the mower blades contacting the ground. Actual height will be dependent on the ground conditions. Increase the height when working in rough or undulating conditions.
- Inspect for broken, chipped, bent, missing, or severely worn blades. Replace damaged blades before operating the mower. Ensure the blade retaining bolts and fasteners are secure and tight.
- Ensure all head bolts and nuts are tight.
- Lubricate the driveline universal joints and telescoping members daily.
- Grease the rotor and roller bearings and inspect their condition.
- Inspect for any oil leaks or damaged hoses.
- Inspect for worn and/or damaged decals and safety instructions. Replace unreadable, damaged or missing safety decals.
- Follow the operator's manual(s) inspection and maintenance instructions for lubricating parts, and keeping thrown object shielding, driveline guards, rotating parts shields, mower blades, and decals in good repair.

Inspect the Tractor for Safe Operating Condition

- Inspect the controls, lights, SMV's (Slow Moving Vehicle sign), seat belts, and ROPS to ensure they are in place and in good working order.
- Ensure tyres, wheels, lug bolts/nuts are in good condition.
- Make sure the tractor brakes and steering are in proper operating condition.
- Follow the operator's manual(s) inspection and maintenance procedures for keeping the tractor in good and safe condition before operating.

Copies of the inspection sheets on the following pages should be retained in this manual for reference; two sets are included to allow removal of one set for photocopying purposes. Alternatively, these inspection sheets can be download from our website via the QR code or using the link below;
<https://my.mcconnel.com/service/pre-operation-inspection-documents/>





POWER ARM PRE-OPERATION INSPECTION



Power Arm ID Date: Shift:



WARNING: Before conducting the inspection, make sure the tractor engine is off, the key removed, all rotation has stopped and the tractor is in park with the parking brake engaged. Make sure the mower head is resting on the ground or is securely blocked up and supported and all hydraulic pressure has been relieved.

Item	Condition at start of shift	Specific Comments if not O.K.
The operator's manual is in the canister on the mower.		
All warning decals are in place, clean and legible.		
All lights are clean and working.		
The mounting frame bolts are in place and tight.		
The arm pivot pins are tight and correctly secured.		
There are no cracks in the arms.		
Hydraulic cylinder pins are tight and correctly secured.		
Hydraulic cylinder hose connections are tight.		
Hydraulic pump hose connections are tight.		
Hydraulic valve hose connections are tight.		
Hydraulic valve controls function properly.		
There are no damaged hoses.		
The oil level is to the green mark on the tank sight glass.		
There is no evidence of hydraulic oil leaks.		
Flails are not missing, chipped, broken or excessively worn.		
The flail bolts are tight.		
The front and rear flaps are fitted and in good condition.		
The front hood is in place and in good condition.		
The wire trap is in good condition.		
The skid shoes are in good condition and tight.		
There are no cracks or holes in flail casing.		
Hydraulic motor mounting bolts are tight.		
All flail head nuts and bolts are tight.		
The rotor bearings are in good condition and greased.		
The roller bearings are in good condition and greased.		
The drive line shaft guard is in good condition.		
The drive line shaft guard is correctly secured.		
Controls are securely mounted in the cab.		
With engine running check arm operation.		
Have a spare pack of flails, bushes, bolts and nuts.		

Operators Signature:

DO NOT OPERATE AN UNSAFE TRACTOR OR MACHINE



TRACTOR PRE-OPERATION INSPECTION

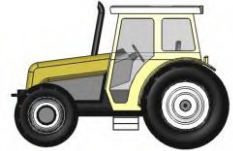

Power Arm ID Date: Shift:



WARNING: Before conducting the inspection, make sure the tractor engine is off, the key removed, all rotation has stopped and the tractor is in park with the parking brake engaged. Ensure any implement attached to the tractor is firmly on the ground.

Item	Condition at start of shift	Specific Comments if not O.K.
The flashing lights function properly.		
All lights are clean and working correctly.		
All cab windows are clean and wipers working correctly.		
The SMV sign, where required, is clean and visible.		
The tyres are in good condition with correct pressure.		
The wheel nuts are tight.		
The tractor brakes are in good condition.		
The steering linkage is in good condition.		
There are no visible oil leaks.		
The hydraulic controls function properly.		
The ROPS or ROPS cab is in good condition.		
The seatbelt is in place and in good condition.		
The 3-point hitch is in good condition.		
The drawbar/pick up hook is secure and in good condition.		
The PTO master shield is in place.		
The engine oil level is full.		
The brake fluid level is full.		
The power steering fluid level is full.		
The fuel level is adequate.		
The engine coolant fluid level is full.		
The radiator and oil cooler are free of debris.		
The air filter is in good condition.		

Operators Signature:

DO NOT OPERATE AN UNSAFE TRACTOR OR MACHINE



POWER ARM PRE-OPERATION INSPECTION

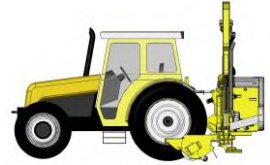

Power Arm ID Date: Shift:



WARNING: Before conducting the inspection, make sure the tractor engine is off, the key removed, all rotation has stopped and the tractor is in park with the parking brake engaged. Make sure the mower head is resting on the ground or is securely blocked up and supported and all hydraulic pressure has been relieved.

Item	Condition at start of shift	Specific Comments if not O.K.
The operator's manual is in the canister on the mower.		
All warning decals are in place, clean and legible.		
All lights are clean and working.		
The mounting frame bolts are in place and tight.		
The arm pivot pins are tight and correctly secured.		
There are no cracks in the arms.		
Hydraulic cylinder pins are tight and correctly secured.		
Hydraulic cylinder hose connections are tight.		
Hydraulic pump hose connections are tight.		
Hydraulic valve hose connections are tight.		
Hydraulic valve controls function properly.		
There are no damaged hoses.		
The oil level is to the green mark on the tank sight glass.		
There is no evidence of hydraulic oil leaks.		
Flails are not missing, chipped, broken or excessively worn.		
The flail bolts are tight.		
The front and rear flaps are fitted and in good condition.		
The front hood is in place and in good condition.		
The wire trap is in good condition.		
The skid shoes are in good condition and tight.		
There are no cracks or holes in flail casing.		
Hydraulic motor mounting bolts are tight.		
All flail head nuts and bolts are tight.		
The rotor bearings are in good condition and greased.		
The roller bearings are in good condition and greased.		
The drive line shaft guard is in good condition.		
The drive line shaft guard is correctly secured.		
Controls are securely mounted in the cab.		
With engine running check arm operation.		
Have a spare pack of flails, bushes, bolts and nuts.		

Operators Signature:

DO NOT OPERATE AN UNSAFE TRACTOR OR MACHINE



TRACTOR PRE-OPERATION INSPECTION

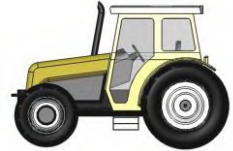

Power Arm ID Date: Shift:



WARNING: Before conducting the inspection, make sure the tractor engine is off, the key removed, all rotation has stopped and the tractor is in park with the parking brake engaged. Ensure any implement attached to the tractor is firmly on the ground.

Item	Condition at start of shift	Specific Comments if not O.K.
The flashing lights function properly.		
All lights are clean and working correctly.		
All cab windows are clean and wipers working correctly.		
The SMV sign, where required, is clean and visible.		
The tyres are in good condition with correct pressure.		
The wheel nuts are tight.		
The tractor brakes are in good condition.		
The steering linkage is in good condition.		
There are no visible oil leaks.		
The hydraulic controls function properly.		
The ROPS or ROPS cab is in good condition.		
The seatbelt is in place and in good condition.		
The 3-point hitch is in good condition.		
The drawbar/pick up hook is secure and in good condition.		
The PTO master shield is in place.		
The engine oil level is full.		
The brake fluid level is full.		
The power steering fluid level is full.		
The fuel level is adequate.		
The engine coolant fluid level is full.		
The radiator and oil cooler are free of debris.		
The air filter is in good condition.		

Operators Signature:

DO NOT OPERATE AN UNSAFE TRACTOR OR MACHINE

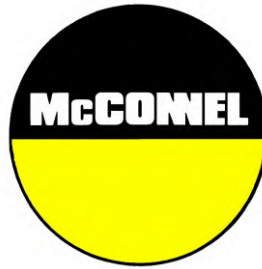

For Safety and Performance...

ALWAYS READ THE BOOK FIRST

McCONEL LIMITED

**Temeside Works
Ludlow
Shropshire
England**

**Telephone: +44 (0)1584 873131
www.mcconel.com**

- NOISE STATEMENT -

The equivalent daily personal noise exposure from this machine measured at the operators' ear is within the range 78 – 85 dB, these figures apply to a normal distribution of use where the noise fluctuates between zero and maximum. The figures assume that the machine is fitted to a tractor with a 'quiet' cab with the windows closed in a generally open environment. We recommend that the windows are kept closed. With the cab rear window open the equivalent daily personal noise exposure will increase to a figure within the range 82 – 88 dB. At an equivalent daily noise exposure level of 85 – 90 dB ear protection is recommended and must always be used if any window is left open.



Operating, servicing and maintaining this equipment can expose you to chemicals including gasoline, diesel fuel, lubricants, petroleum products, engine exhaust, carbon monoxide, and phthalates, which are known to the State of California to cause cancer and birth defects or other reproductive harm. To minimize exposure, avoid breathing exhaust, do not idle the engine except as necessary, service your vehicle in a well-ventilated area and wear gloves or wash your hands frequently when servicing your vehicle. Battery posts, terminals and related accessories contain lead and lead compounds, chemicals known to the state of California to cause cancer, birth defects or other reproductive harm. For more information go to www.P65Warnings.ca.gov. This website, operated by California's Office of Environmental Health Hazard Assessment, provides information about these chemicals and how individuals may be exposed to them.

CONTENTS

General Information	1
Features	2
Safety Information	4
Fitting (Tractor Requirements)	11
Tractor Preparation	12
Delivery & Pre-Attachment	13
Hydraulic Oil	14
Stabilizers	15
Attachment to Tractor	17
PTO Driveshaft Installation	21
Control Unit Installation	22
Flailhead Attachment	23
Running Up Procedure	24
Emergency Stopping	24
Pre-Work Preparation & Precautions	25
Removal From Tractor	26
Storage	26
Operation	27
Operator Control Systems	28
Cable Controls	29
Cable Rotor Control	32
Slew & Lift Locks	33
Breakaway	34
Powered Slew	35
Moving Into Transport Position	36
Transporting The Machine	37
Moving from Transport to Work	38
Operating Speeds	39
Hazards & Dangers	40
Overhead Power Lines	41
Hedgecutting Procedure	43
Lift Float (Option)	44
Angle Float	45
Maintenance	46
Troubleshooting Chart	54

GENERAL INFORMATION

Read this manual before fitting or operating the machine. Whenever any doubt exists contact your dealer or the McConnel Service Department for assistance.

Use only McConnel Genuine Parts on McConnel equipment and machines.

DEFINITIONS - The following definitions apply throughout this manual:

WARNING:

An operating procedure, technique etc., which can result in personal injury or loss of life if not observed carefully.

CAUTION:

An operating procedure, technique etc., which can result in the damage of either machine or equipment if not observed carefully.

NOTE:

An operating procedure, technique etc., which is considered essential to emphasise.

LEFT AND RIGHT HAND:

This term is applicable to the machine when fitted to the tractor and viewed from the rear. This also applies to tractor references.

Note: The illustrations in this manual are for instructional purposes only and may on occasion not show some components in their entirety. In some instances an illustration may appear slightly different to that of your particular model but the general procedure will be the same. E&OE.

MACHINE & DEALER INFORMATION

Record the Serial Number of your machine on this page and always quote this number when ordering parts. Whenever information concerning the machine is requested remember also to state the make and model of tractor to which the machine is fitted.

Machine Serial Number:	Installation Date:
Machine Model details:	
Dealer Name:	
Dealer Address:	
Dealer Telephone No:	
Dealer Email Address:	

FEATURES

PA5055 Eco Models

- Linkage mounted.
- 5.0m reach
- Right hand cutting.
- Operator guard.
- Hydraulic safety breakaway.
- 95° powered slew.
- 180 litre hydraulic reservoir.
- Storage support legs.
- Choice of Flailheads.
- Choice of Controls.

PA5555 Eco Models

- Linkage mounted.
- 5.5m reach
- Right hand cutting.
- Operator guard.
- Hydraulic safety breakaway.
- 95° powered slew.
- 180 litre hydraulic reservoir.
- Storage support legs.
- Choice of Flailheads.
- Choice of Controls.

PA6055 Eco Models

- Linkage mounted.
- 6.0m reach
- Right hand cutting.
- Operator guard.
- Hydraulic safety breakaway.
- 95° powered slew.
- 180 litre hydraulic reservoir.
- Storage support legs.
- Choice of Flailheads.
- Choice of Controls.

Options

- Lift Float Kit
- Lighting Kit
- Cooler Kit



This machine has the potential to be extremely dangerous - in the wrong hands it can kill or maim; It is therefore imperative that both owner and operator of the machine reads and understands the following section to ensure they are fully aware of the dangers that do, or may exist, and their responsibilities surrounding the use and operation of the machine.

The operator of this machine is responsible not only for their own safety but equally for the safety of others who may come into the close proximity of the machine, as the owner you are responsible for both.

When the machine is not in use the cutting head should be lowered to rest on the ground. In the event of any fault being detected with the machine's operation it must be stopped immediately and not used again until the fault has been corrected by a qualified technician.

POTENTIAL SIGNIFICANT DANGERS ASSOCIATED WITH THE USE OF THIS MACHINE:

- ▲ *Being hit by debris thrown by rotating components.*
- ▲ *Being hit by machine parts ejected through damage during use.*
- ▲ *Being caught on a rotating power take-off (PTO) shaft.*
- ▲ *Being caught in other moving parts i.e.: belts, pulleys and cutting heads.*
- ▲ *Electrocution from Overhead Power Lines (by contact with or 'flashover' from).*
- ▲ *Being hit by cutting heads or machine arms as they move.*
- ▲ *Becoming trapped between tractor and machine when hitching or unhitching.*
- ▲ *Tractor overbalancing when machine arm is extended.*
- ▲ *Injection of high-pressure oil from hydraulic hoses or couplings.*
- ▲ *Machine overbalancing when freestanding (out of use).*
- ▲ *Road traffic accidents due to collision or debris on the road.*
- ▲ *Burn risk from hot components.*

BEFORE USING THIS MACHINE YOU MUST:

- ▲ *Ensure you read all sections of the operator handbook.*
- ▲ *Ensure the operator is, or has been, properly trained to use the machine.*
- ▲ *Ensure the operator has been issued with and reads the operator handbook.*
- ▲ *Ensure the operator understands and follows the instructions in operator handbook.*
- ▲ *Ensure the tractor front, rear and sides are fitted with metal mesh or polycarbonate guards of suitable size and strength to protect the operator against thrown debris or parts.*
- ▲ *Ensure tractor guards are fitted correctly, are undamaged and kept properly maintained.*
- ▲ *Ensure that all machine guards are in position, are undamaged, and are kept maintained in accordance with the manufacturer's recommendations.*
- ▲ *Ensure flails and their fixings are of a type recommended by the manufacturer, are securely attached and that none are missing or damaged.*
- ▲ *Ensure hydraulic pipes are carefully and correctly routed to avoid damage by chaffing, stretching or pinching and that they are held in place with the correct fittings.*
- ▲ *Always follow the manufacturer's instructions for attachment and removal of the machine from the tractor.*
- ▲ *Check that the machine fittings and couplings are in good condition.*
- ▲ *Ensure the tractor meets the minimum weight recommendations of the machine's manufacturer and that ballast is used as necessary.*
- ▲ *Always inspect the work area thoroughly before starting to note obstacles and remove wire, bottles, cans and other debris.*
- ▲ *Use clear suitably sized warning signs to alert others to the nature of the machine working within that area. Signs should be placed at both ends of the work site. (It is recommended that signs used are of a size and type specified by the Department of Transport and positioned in accordance with their, and the Local Highways Authority, guidelines).*
- ▲ *Ensure the operator is protected from noise. Ear defenders should be worn and tractor cab doors and windows must be kept closed. Machine controls should be routed through proprietary openings in the cab to enable all windows to be shut fully.*
- ▲ *Always work at a safe speed taking account of the conditions i.e.: terrain, highway proximity and obstacles around and above the machine. Extra special attention should be applied to Overhead Power Lines. Some of our machines are capable of reach in excess of 8 metres (26 feet) this means they have the potential to well exceed, by possibly 3 metres (9' 9"), the lowest legal minimum height of 5.2 metres from the ground for 11,000 and 33,000 volt power lines. It cannot be stressed enough the dangers that surround this capability, it is therefore vital that the operator is fully aware of the maximum height and reach of the machine, and that they are fully conversant with all aspects regarding the safe minimum distances that apply when working with machines in close proximity to Power Lines. (Further information on this subject can be obtained from the Health & Safety Executive or your Local Power Company).*

- ▲ *Always disengage the machine, kill the tractor engine, remove and pocket the key before dismounting for any reason.*
- ▲ *Always clear up all debris left at the work area, it may cause hazard to others.*
- ▲ *Always ensure when you remove your machine from the tractor that it is left in a safe and stable position using the stands and props provided and secured if necessary.*

WHEN NOT TO USE THIS MACHINE:

- ▲ *Never attempt to use this machine if you have not been trained to do so.*
- ▲ *Never use a machine until you have read and understood the operator handbook, are familiar with it, and practiced the controls.*
- ▲ *Never use a machine that is poorly maintained.*
- ▲ *Never use a machine if guards are missing or damaged.*
- ▲ *Never use a machine on which the hydraulic system shows signs of wear or damage.*
- ▲ *Never fit, or use, a machine on a tractor that does not meet the manufacturer's minimum specification level.*
- ▲ *Never use a machine fitted to a tractor that does not have suitable front, rear and side(s) cab guarding made of metal mesh or polycarbonate.*
- ▲ *Never use the machine if the tractor cab guarding is damaged, deteriorating or badly fitted.*
- ▲ *Never turn a machine cutting head to an angle that causes debris to be ejected towards the cab.*
- ▲ *Never start or continue to work a machine if people are nearby or approaching - Stop and wait until they are at a safe distance before continuing. WARNING: Some cutting heads may continue to 'freewheel' for up to 40 seconds after being stopped.*
- ▲ *Never attempt to use a machine on materials in excess of its capability.*
- ▲ *Never use a machine to perform a task it has not been designed to do.*
- ▲ *Never operate the tractor or machine controls from any position other than from the driving seat, especially whilst hitching or unhitching the machine.*
- ▲ *Never carry out maintenance of a machine or a tractor whilst the engine is running – the engine should be switched off, the key removed and pocketed.*
- ▲ *Never leave a machine unattended in a raised position – it should be lowered to the ground in a safe position on a level firm site.*
- ▲ *Never leave a tractor with the key in or the engine running.*
- ▲ *Never carry out maintenance on any part or component of a machine that is raised unless that part or component has been properly substantially braced or supported.*
- ▲ *Never attempt to detect a hydraulic leak with your hand – use a piece of cardboard.*
- ▲ *Never allow children near to, or play on, a tractor or machine under any circumstances.*

ADDITIONAL SAFETY ADVICE

Training

Operators need to be competent and fully capable of operating this machine in a safe and efficient way prior to attempting to use it in any public place. We advise therefore that the prospective operator make use of relevant training courses available such as those run by the Agricultural Training Board, Agricultural Colleges, Dealers and McConnel.

Working in Public Places

When working in public places such as roadsides, consideration should be paid to others in the vicinity. Stop the machine immediately when pedestrians, cyclists and horse riders etc. pass. Restart only when they are at a distance that causes no risk to their safety.

Warning Signs

It is advisable that any working area be covered by suitable warning signs and statutory in public places. Signs should be highly visible and well placed in order to give clear advanced warning of the hazard. Contact the Department of Transport or your Local Highways Authority to obtain detailed information on this subject. The latter should be contacted prior to working on the public highway advising them of the time and location of the intended work asking what is required by way of signs and procedure. – ‘*Non-authorized placement of road signs may create offences under the Highways Act*’.

Suggested Warning Signs Required

‘Road works ahead’ warning sign with a supplementary ‘Hedge cutting’ plate. ‘For 1 mile’ or appropriate shorter distance may be added to the plate.

‘Road narrows’ warning signs with supplementary ‘Single file traffic’ plate.

White on blue ‘Keep right’ () arrow sign on rear of machine.*

** Note – this applies to UK Market machines where traffic passes to the right of a machine working in the same direction as the traffic flow. The direction, use and colour of the arrow sign will depend on the country of use and the Local Highway Authorities regulations in the locality.*

Use of Warning Signs

- ▲ *On two-way roads one set of signs is needed facing traffic in each direction.*
- ▲ *Work should be within 1 mile of the signs.*
- ▲ *Work only when visibility is good and at times of low risk e.g.: NOT during ‘rush-hour’.*
- ▲ *Vehicles should have an amber-flashing beacon.*
- ▲ *Ideally, vehicles should be conspicuously coloured.*
- ▲ *Debris should be removed from the road and path as soon as practicable, and at regular intervals, wearing high visibility clothing and before removing the hazard warning signs.*
- ▲ *Collect all road signs promptly when the job is completed.*

Although the information stated here covers a wide range of safety subjects it is impossible to predict every eventuality that can occur under differing circumstances whilst operating this machine. No advice given here can replace ‘good common sense’ and ‘total awareness’ at all times, but will go a long way towards the safe use of your McConnel machine.

Safe use of rotary flail hedge cutters

HSE information sheet

Agriculture Information Sheet No 21 (Revision 1)

Introduction

This information sheet outlines typical hazards when using most types of tractor-mounted rotary flail hedge cutter. It gives guidance on reducing risks to the operator and others during work with hedge cutters and will help employers, employees and the self-employed comply with their duties under health and safety law.

All users of rotary flail hedge cutters need to be aware of the particular features of their make/model of hedge cutter when considering the hazards, risks and precautions.

Hazards

The greatest risk of injury comes from contact with the machine's moving parts and in particular:

- entanglement on inadequately guarded power take-off shafts;
- contact with the cutter head parts, drive belts or pulleys;
- being struck by the cutting head or machine arm as it moves.

Other risks associated with tractor-mounted hedge cutters can include:

- being hit by material or other debris ejected by the cutters;
- being hit by component parts ejected from the machine;
- coming into contact with overhead electricity power lines (OHPLs);
- the tractor overbalancing when the machine arm is extended;
- injection of high-pressure oil from damaged hydraulic hoses or couplings;
- being struck by the machine overbalancing when un-hitched from the tractor;
- road traffic accidents due to collisions with other vehicles either directly or from debris on the road.

Control measures

It is extremely dangerous to carry out any work on a machine while it is under power. The most important safety measure is to follow the 'safe stop' procedure before dismounting, or carrying out any maintenance or adjustments, including dealing with a blockage or other problem:

- Handbrake on.
- Controls neutral.
- Stop engine.
- Remove key.

Guards and machine safety

Check that all guards and other protective devices are in place before starting work. Don't use the machine if the guards are missing or damaged. Make sure:

- the power take-off (PTO) shaft is fully enclosed in a guard along its entire length from the tractor power take-off to the power input connection on the hedge cutter;
- the tractor rear and side(s) are fitted with protective glazing, metal mesh or polycarbonate guards of a size/strength specified by the hedge cutter manufacturer to protect the operator against thrown debris or other projectiles;
- tractor mesh/polycarbonate guards are suitable for the job, undamaged and maintained in accordance with the manufacturer's instructions;
- all hedge cutter guards and safety devices are in position, correctly fitted and maintained in accordance with the manufacturer's recommendations;
- flails and their fixing heads are the right size for the task. Flails, and their fixings, should be of the type recommended by the manufacturer, securely attached, and should not be missing or damaged;
- hydraulic pipes are carefully routed to avoid damage;
- machine fittings and couplings are in good condition.

General guidance on safe working practice

- Operators should receive adequate instructions and training to enable them to use the machine safely. Take advantage of relevant training/courses provided by manufacturers/dealers. They will help ensure your safety and that of your staff, and help you get the best performance from your hedge cutter.
- Make sure the operator reads, understands and follows the instruction manual.
- Follow the manufacturer's instructions when hitching or unhitching the machine from the tractor. Do not stand in any position where you may be at risk of being crushed, eg in the area between the back of the tractor and the cutter.
- Make sure the machine is left in a stable position when it is removed from the tractor, using any stands or props provided, and securing it further if necessary.
- Do not carry out maintenance on the hedge cutter with the cutting arm/dipper arm raised, unless the arm is properly supported.
- Check the tractor is at least the minimum weight recommended by the hedge cutter manufacturer. Use ballast as necessary.
- Inspect the hedge before starting to cut and remove wire, bottles, cans and other debris. Check for any telegraph/electricity pole stays. Damaged stays should be reported to the relevant Telecoms Company/Distribution Network Operator.
- Use appropriate warning signs to alert others to the hedge-cutting operation where necessary.
- Work at a safe speed, taking account of the conditions (eg terrain, proximity to the highway, or obstacles).
- Use safe practices when work needs to be done near OHPLs. Flailhead units on some dipper arms can reach over 5.2 metres, the minimum height of OHPLs above ground level (see Further reading).
- Clear up debris after cutting if it could be a hazard to others.

Roadside hedges

Take extra care if you are hedge/verge cutting along a road. Consider what measures you will need to control the risks to other road users (eg vehicles, cyclists, pedestrians, or horse riders). For roadside work (on the public highway) there are other legal requirements. For example, there may be obligations to:

- display specific warning signs in defined locations where work is carried out;
- fit flashing beacons to tractors/machines;
- clear debris from paths and roads;
- restrict your working hours.

Consult your local authority highways department and the Department for Transport for advice (see Further reading).

Further reading

Traffic signs manual 2009. Chapter 8. Traffic safety measures and signs for road works and temporary situations. Part 2: Operations DfT ISBN 978 0 11 553052 4 <http://assets.dft.gov.uk/publications/traffic-signs-manual/traffic-signs-manual-chapter-08-part-02.pdf>

Working safely near overhead electricity power lines AIS8(rev3) HSE Books 2012 www.hse.gov.uk/pubns/ais8.htm

Further information

For information about health and safety, or to report inconsistencies or inaccuracies in this guidance, visit www.hse.gov.uk/. You can view HSE guidance online and order priced publications from the website. HSE priced publications are also available from bookshops.

This guidance is issued by the Health and Safety Executive. Following the guidance is not compulsory, unless specifically stated, and you are free to take other action. But if you do follow the guidance you will normally be doing enough to comply with the law. Health and safety inspectors seek to secure compliance with the law and may refer to this guidance.

This document is available at www.hse.gov.uk/pubns/ais21.htm.

© *Crown copyright* If you wish to reuse this information visit www.hse.gov.uk/copyright.htm for details. First published 10/12.

SAFETY & INFORMATION DECALS (Power Arms)

Power Arm machines are equipped with safety and information decals designed to warn of dangers, operational information and machine protection. Operators must understand the decals and heed all warnings. Keep decals in a good condition and replace immediately if they are damaged or missing.



1.



2.



3.

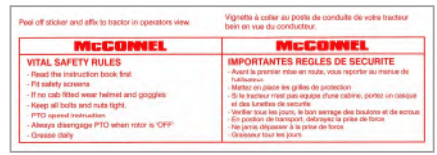

4.



5.



6.



7.



8.



9.

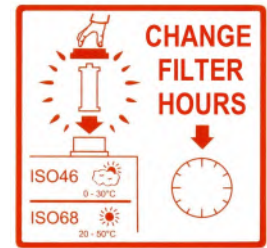

10.



11.



12.



13.



14.



15.

1. General Safety Warnings.
2. Driveline Hazard Warning.
3. Tighten Check Chains Warning.
4. 'In vehicle' Safety Rules Decal.
5. Serial Number Plate.
6. Read the Book First.
7. Lift Point with SWL (Kg).
8. Specific Pinch Point Warning.
9. Maximum vehicle PTO Speed & Direction Warning.
10. Oil Filter Initial and subsequent change information.
11. Lift Point for shipping only; stow when machine installed on vehicle. (Models with stowable lift eyes only).
12. Auto-breakaway Return Warning; in 'Auto-Reset' arm will automatically return to the work position, when possible.
13. Vehicle Clearance Warning; leave 300mm+ between arm and vehicle.
14. Lift Stop Clearance Warning; leave 300mm+ between arm and vehicle, leave 5mm between arm and stop.
15. Lift Tap 'Lock' Warning; leave 300mm+ between arm and vehicle, lock lift taps for transport.

SAFETY & INFORMATION DECALS (Flail Heads)

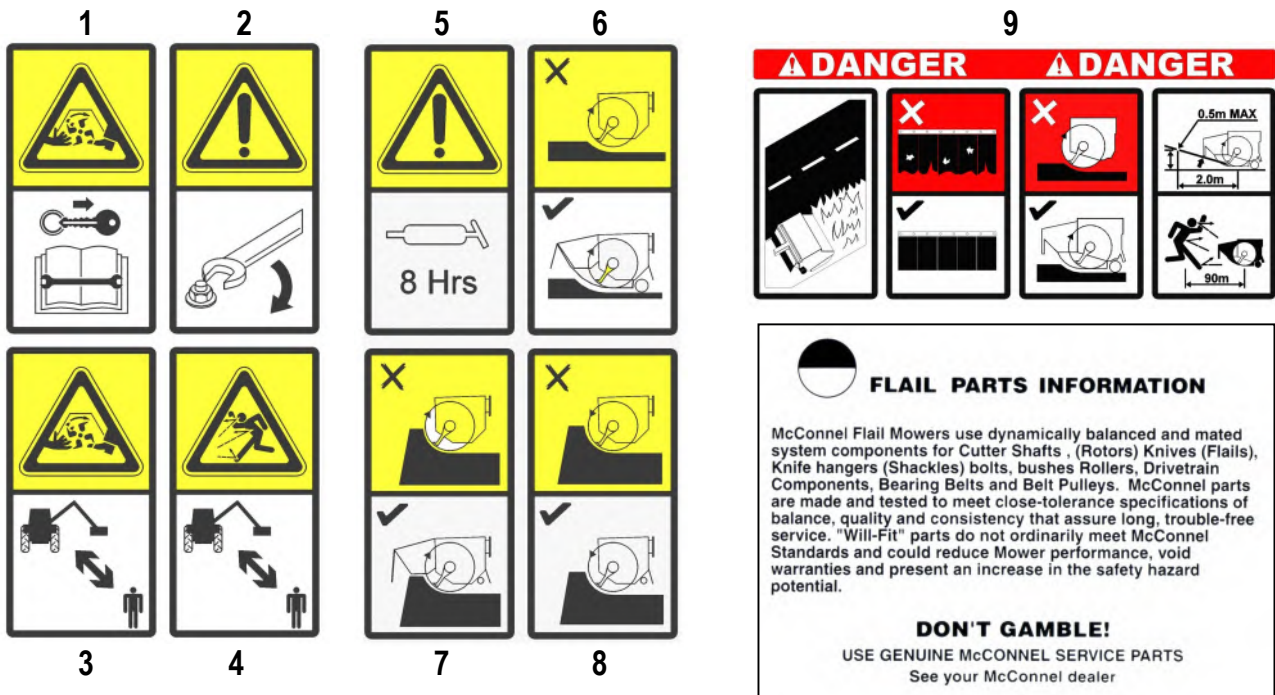

1. **Caution!** Rotating blades; keep clear of machine, stop machine (wait for rotor to stop), remove vehicle key and read the book first before performing any service or maintenance.
2. **Caution!** Keep all nuts and bolts tight.
3. **Caution!** Rotating components; keep clear of the working machine.
4. **Caution!** Thrown objects risk; keep all persons at a safe distance from the working machine.
5. **Caution!** Lubricate greasing points every 8 working hours.
6. **Caution!** Grass/Verge Mowing; front hood, front flap, rear roller and rear flap must be fitted and correctly adjusted when using the machine for grass and verge mowing. Flaps must be in good condition.
7. **Caution!** Hedging (Uphill cutting); front hood, front flap and rear flap must always be fitted and correctly adjusted. Rear roller should be placed into the raised position. Flaps must be in good condition.
8. **Caution!** Hedging (Downhill cutting); front hood may be removed; rear flap must be fitted and rear roller placed into the raised position. Flap must be in good condition.
9. **Danger!** Road side mowing. Flaps must be in good condition. Do not work if front hood, front flaps, rear roller and rear flaps not fitted. Front hood, front flaps, rear roller and rear flaps must be fitted. Adjust front hood to the correct height position for verge mowing. A extended straight line from the bottom of the rotor and bottom of the front flap should not be higher than 0.5m at a horizontal distance of 2.0m from the rotor. Keep all persons at 90m from the working machine, stop machine if persons are closer. *Refer to front hood height setting section for details.*
10. **Important!** Parts information; for safety and performance only use 'Genuine McConnel Service Parts'.

FITTING – Tractor requirements

Minimum Tractor Weight - *including ballast weight if necessary:*

PA5055 ECO Model – 3500kg.

PA5555 ECO Model – 3500kg.

PA6055 ECO Model – 4000kg.

Minimum Tractor HP

All models – 65HP

Linkage

Category 2

PTO Shaft

Tractor must be equipped with a live drive PTO to enable forward motion to be stopped while the flail head continues to operate.

Check Chains/Stabilizers:

Check chains or stabilizers must be fitted and tightened.

VEHICLE/ TRACTOR PREPARATION

We recommend vehicles are fitted with cabs using safety glass windows and protective guarding when used with our machines.

Fit Operator Guard (part no. 73 13 324) using the hooks provided. Shape mesh to cover all vulnerable areas.

Remember the driver must be looking through mesh and/or polycarbonate glazing when viewing the flail head in any working position - unless the vehicle/ cab manufacturer can demonstrate that the penetration resistance is equivalent to, or higher than, that provided by mesh/polycarbonate glazing. If the tractor has a roll bar only, a frame must be made to carry both mesh and polycarbonate glazing. The operator should also use personal protective equipment to reduce the risk of serious injury such as; eye protection (mesh visor to EN1731 or safety glasses to EN166), hearing protection to EN352, safety helmet to EN297, gloves, filter mask and high visibility clothing.

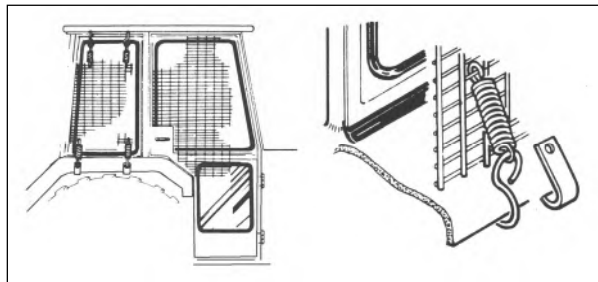

Vehicle Ballast: It is imperative when attaching 'third-party' equipment to a vehicle that the maximum possible stability of the machine and vehicle combination is achieved – this can be accomplished by the utilisation of 'ballast' in order to counter-balance the additional equipment added.

Front weights may be required for rear mounted machines to place 15% of total outfit weight on the front axle for stable transport on the road and to reduce 'crabbing' due to the drag of the cutting unit when working on the ground.

Rear weights may be required to maintain a reasonable amount of rear axle load on the opposite wheel from the arms when in work; for normal off-ground work i.e. hedge cutting this should be 20% of rear axle weight or more for adequate control, and for ground work i.e. verge mowing with experienced operators, this can be reduced to 10%.

All factors must be addressed in order to match the type and nature of the equipment added to the circumstances under which it will be used – in the instance of Power Arm hedgecutters it must be remembered that the machines centre of gravity during work will be constantly moving and will differ from that during transport mode, therefore balance becomes critical.

Factors that effect stability:

- *Centre of gravity of the tractor/machine combination.*
- *Geometric conditions, e.g. position of the cutting head and ballast.*
- *Weight, track width and wheelbase of the tractor.*
- *Acceleration, braking, turning and the relative position of the cutting head during these operations.*
- *Ground conditions, e.g. slope, grip, load capability of the soil/surface.*
- *Rigidity of implement mounting.*

Suggestions to increase stability:

- *Increasing rear wheel track; a vehicle with a wider wheel track is more stable.*
- *Ballasting the wheel; it is preferable to use external weights but liquid can be added to around 75% of the tyre volume – water with anti-freeze or the heavier Calcium Chloride alternative can be used.*
- *Addition of weights – care should be taken in selecting the location of the weights to ensure they are added to a position that offers the greatest advantage.*
- *Front axle locking, check with tractor manufacturer.*

The advice above is offered as a guide for stability only and is not a guide to vehicle strength. It is therefore recommended that you consult your vehicle manufacturer or local dealer to obtain specific advice on this subject, additionally advice should be sought from a tyre specialist with regard to tyre pressures and ratings suitable for the type and nature of the machine you intend to fit.

DELIVERY & PRE-ATTACHMENT (Dealer Reference)

Delivery

The machine will be delivered in a partially dismantled condition secured with transport straps and banding. Select a firm level site on which to place the machine before removing the straps, banding and other loose items.

Handling the Machine

Handling of the machine should always be performed using suitable overhead lifting equipment with a minimum safe lifting capacity over and above the maximum weight of the machine. Always ensure the machine is balanced during the lifting procedure and that all bystanders are kept well clear of the raised machine.

Post Delivery Assembly

To allow for a compact shipping state the machine will be delivered with the tension link disconnected from the rocker and the stand legs retracted – these items will need to be correctly installed before initial attachment to a tractor. *The procedure is as follows:*

Stand Legs

Raise the machine using suitable overhead lifting equipment.

Lower stand legs and secure in position using pins and locking pins – the hole position selected should be at a height that places the gearbox stub axle approximately 75mm (3”) below the height of the tractor’s PTO shaft when the machine is at rest on the ground. Note the hole position used and ensure the equivalent one is used on both sides of the machine

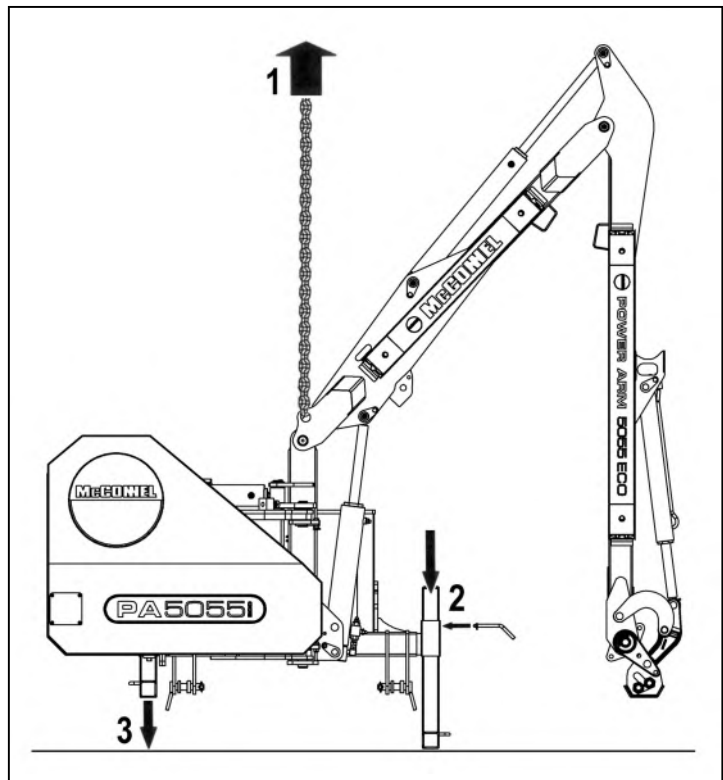

HYDRAULIC OIL

Hydraulic Oil Reservoir

Fill the tank with oil selected from the chart below or a good quality equivalent to a point where the level is between the minimum and maximum marks on the tank gauge. When the machine is initially run the level will drop as the oil is drawn into the circuit - *top back up as required to the correct level on the gauge.*

Always use clean receptacles when handling and transferring oil to avoid moisture or dirt contamination that can damage components and/or reduce machine performance.

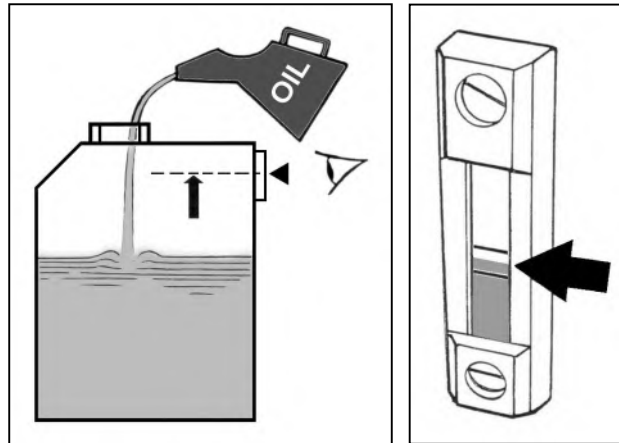

NOTE: Refer to the maintenance section for further information on the subject of hydraulic oil and system filtration.

Reservoir Capacity

The oil tank capacity of the machine is approximately **180 Litres**.

Recommended Hydraulic Oils

For initial filling of the oil reservoir, periodic oil changes and replenishment purposes the following hydraulic oils, or a good quality equivalent are recommended:

NOTE: Only use oils that are ISO 18/16/13, NAS7, or cleaner.

Manufacturer	Cold or Temperate Climate	Hot Climate
BP	Bartran 46 Energol HLP-HM 46	Bartran 68 Energol HLP-HM 68
CASTROL	Hyspin AWH-M 46	Hyspin AWH-M 68
COMMA	Hydraulic Oil LIC 15	Hydraulic Oil LIC 20
ELF	Hydrelf HV 46 Hydrelf XV 46	Hydrelf HV 68
ESSO	Univis N 46	Univis N 68
FUCHS (UK/Non UK markets*)	Renolin 46 Renolin HVZ 46 Renolin CL46/B15* Renolin AF46/ZAF46B*	Renolin 68 Renolin HVZ 68 Renolin CL68/B20* Renolin AF68/ZAF68B*
GREENWAY	Excelpower HY 68	Excelpower HY 68
MILLERS	Millmax 46 Millmax HV 46	Millmax 68 Millmax HV 68
MORRIS	Liquimatic 5 Liquimatic HV 46 Triad 46	Liquimatic 6 Liquimatic HV 68 Triad 68
SHELL	Tellus 46 Tellus T46	Tellus 68 Tellus T68
TEXACO	Rando HD 46 Rando HDZ 46	Rando HD 68 Rando HDZ 68
TOTAL	Equivis ZS 46	Equivis ZS 68

STABILIZERS (3-Point Linkage Models only)

Standard Stabilizer Types Identification

As standard, 3-point linkage machines are fitted with either a 'slotted' type stabilizer or a 'multi-hole' type stabilizer; the particular one used is dependent on the specific machine build. Machines with Standard arm-sets use the 'slotted' type and machines with Midcut or VFR arm-sets use the 'multi-hole' type; *for identification refer to the illustrations below.*

Slotted Type Stabilizer

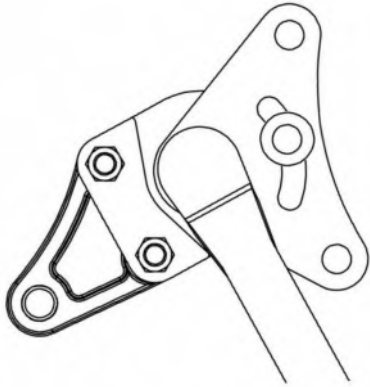

Machines with standard arm-sets.

Multi-hole Type Stabilizer

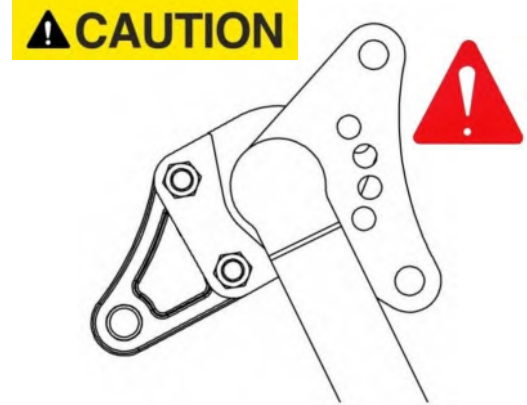

Machines with Midcut or VFR arm-sets.

CAUTION

On machines equipped with multi-hole type stabilizers it is vital that the stabilizer position pin is always removed for machine transport and only fitted for work; failure to observe this can result in serious damage to machine and/or tractor components.

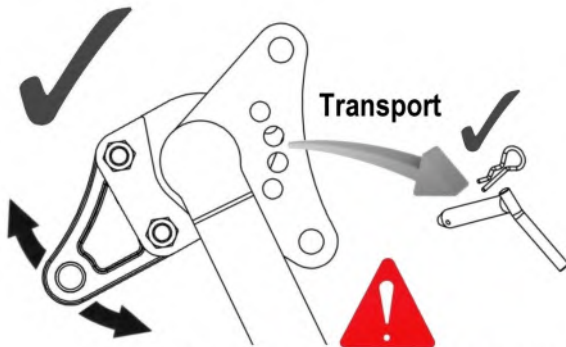

Pin must be removed for transport

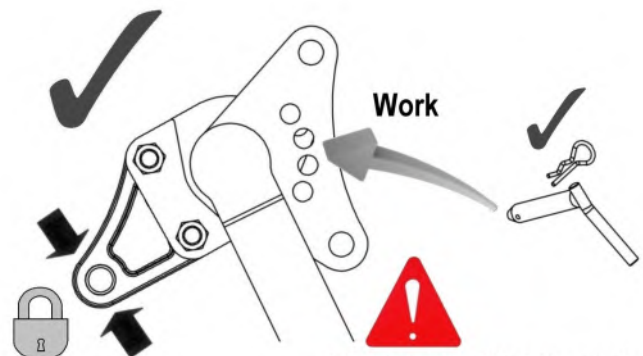

Pin must be fitted for work

Position Pin Fitting & Removal (Multi-hole type stabilizers)

Insertion or removal of the position pin is best performed whilst the machine in its transport position as the forces acting on the stabilizer are greatly reduced; this will make the task of insertion or removal much easier. Always stow the position pin in a safe location when it is not in use.

Stabilizer Tongues

McConnel bolt on stabilizer tongues are available in a wide variety of versions to suit differing makes and models of tractors and are reversible to accommodate for greater variation in tractor linkage designs; *refer to following page for details.*

Stabilizer Tongue Options & Specifications

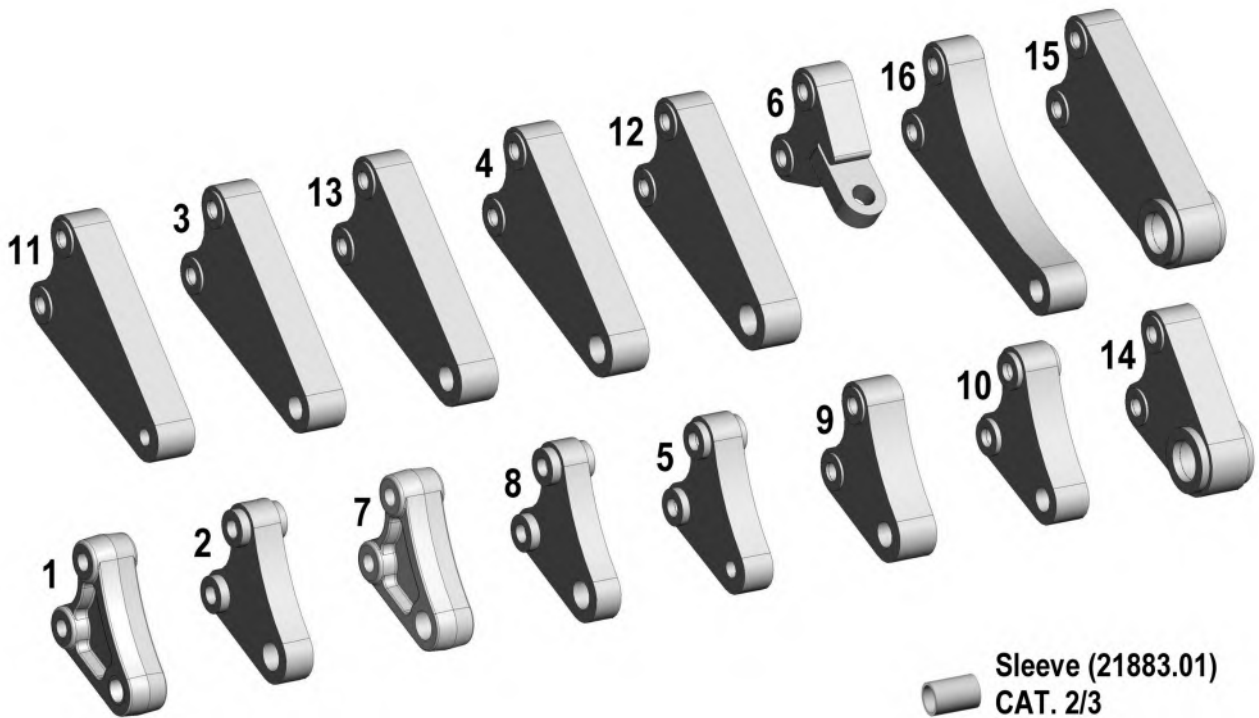

McConel Stabilizer Tongues

- 'A' – Hole diameter
- 'B' – Hole centre spacing
- 'C' – Stabilizer width

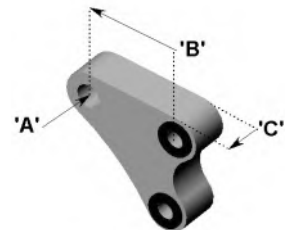

(Dimensions in mm)

Ref.	Part No.	Description	'A'	'B'	'C'
1	7499501	Tongue: Standard CAT. 2/3	32.0	107.5	45.0
2	7499500	Tongue: Special CAT. 2/3 narrow	32.0	107.5	35.0
3	7499502	Tongue: Special CAT. 2 long	27.0	217.4	45.0
4	7499503	Tongue: Special CAT. 3 long	32.0	217.4	45.0
5	7499504	Tongue: Special CAT. 1	19.5	107.5	35.0
6	7499505	Tongue: Special CAT. 2 for Case TX tractors	25.0	120.0	50.0
7	7499506	Tongue: Special CAT. 3	32.0	107.5	45.0
8	7499507	Tongue: Special CAT. 3 narrow	32.0	107.5	30.0
9	7499508	Tongue: Special for some Ford tractors	28.6	107.5	45.0
10	7499510	Tongue: Special CAT. 2	27.0	107.5	40.0
11	7499511	Tongue: Special CAT. 1	19.5	217.4	45.0
12	7499512	Tongue: Special	35.0	217.4	45.0
13	7499513	Tongue: Special	28.6	217.4	45.0
14	7499514	Tongue: Special CAT. 4	45.2	107.5	63.5
15	7499515	Tongue: Special CAT. 4 long	45.2	217.4	63.5
16	7499262	Tongue: Special CAT. 2 extra long for Aebi	27.0	260.1	45.0

ATTACHMENT TO TRACTOR

Position the tractor squarely to the machine placing the draft links at the same height as the mainframe attachment points.

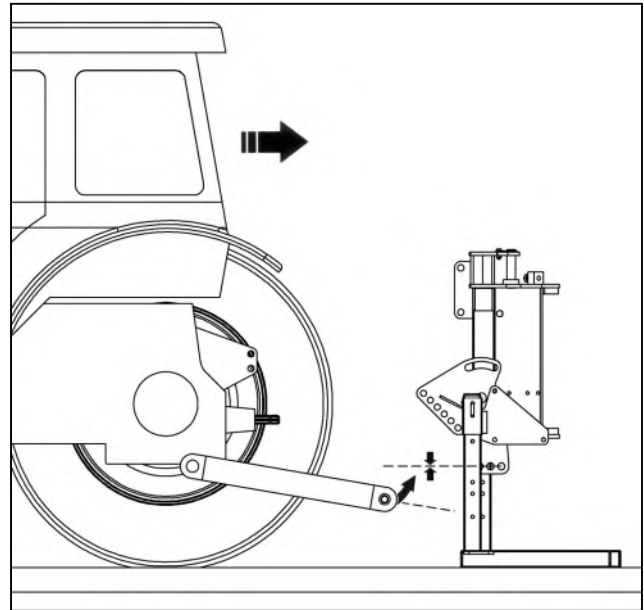

Carefully reverse the tractor up to the machine until the draft links are positioned for attachment – *select the rear most hole on the machines lower link brackets that allows the machine to be mounted without fouling the tractor.*

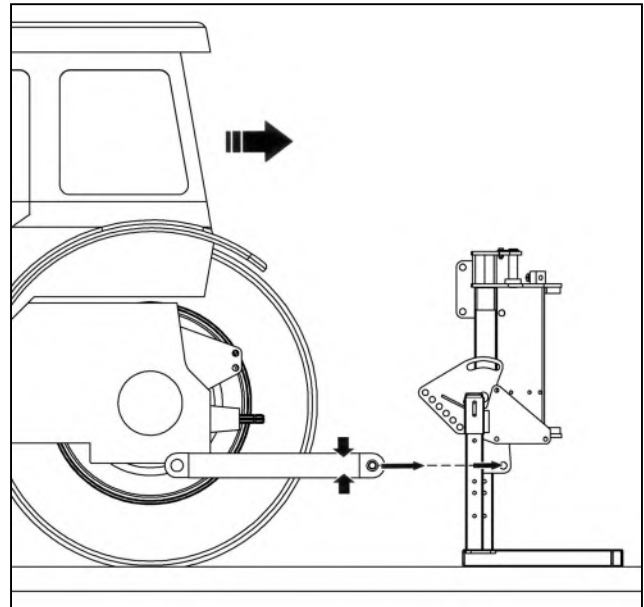

Attach the tractor draft links to the machine using pins provided and secure in position - *ensure the same mounting hole is selected on each side of the machine.*

If necessary fit the spacers supplied to minimise sideways movement of the draft links within the hitch bracket

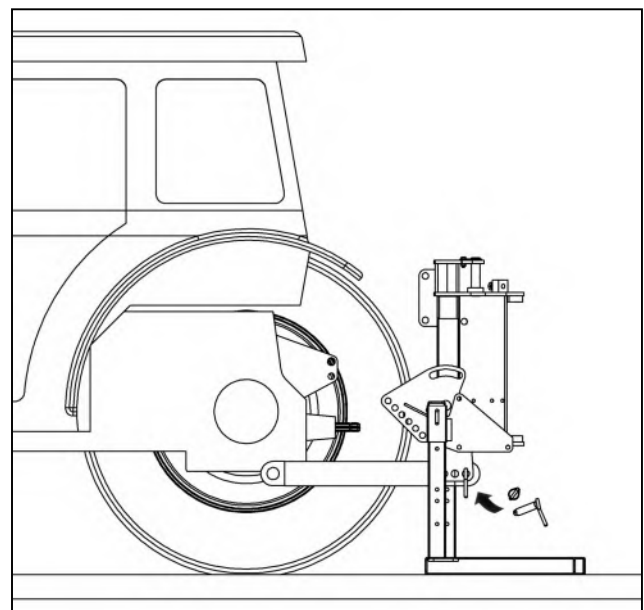

Fit the stabilizer into position with its arms aligned with the holes of the main frame and attach the stabilizer nose to the tractors top link – *select the highest possible position available avoiding any load sensing properties.*

NOTE: The bolt on nose of the stabiliser is reversible in order to accommodate variations of tractor linkage designs.

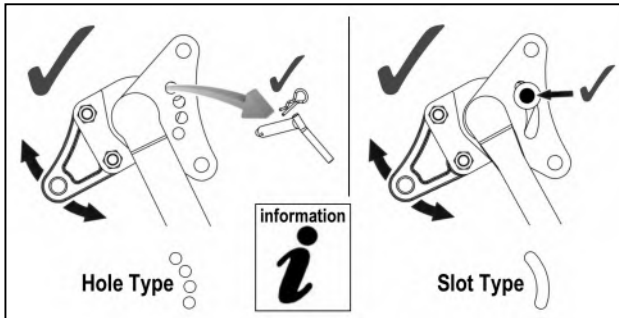

Secure the stabiliser in position using the fixings provided. Attach the stabiliser arm to the machine selecting the lowest hole possible.

Fit top link between the stabiliser and the mainframes upper linkage point.

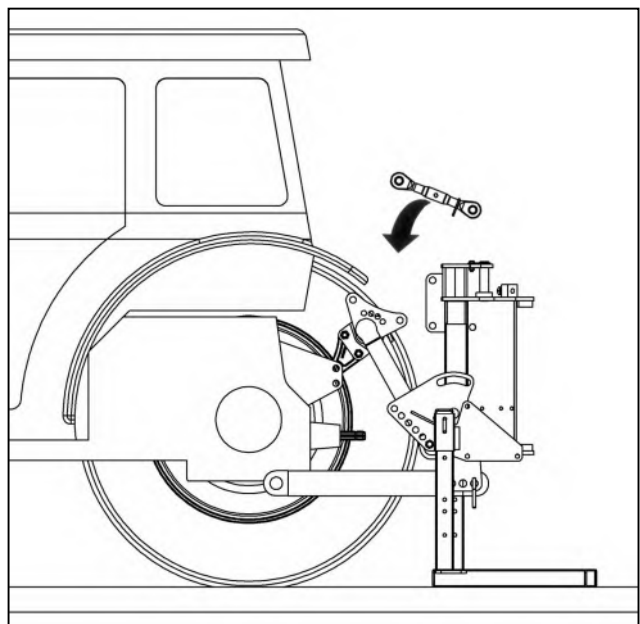
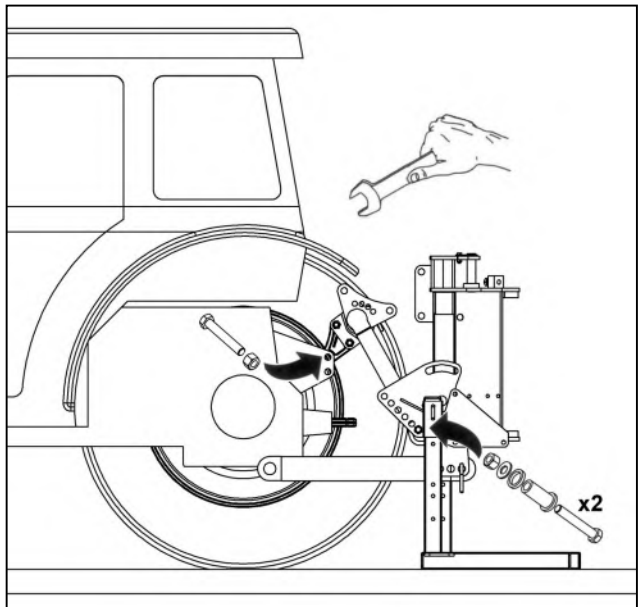
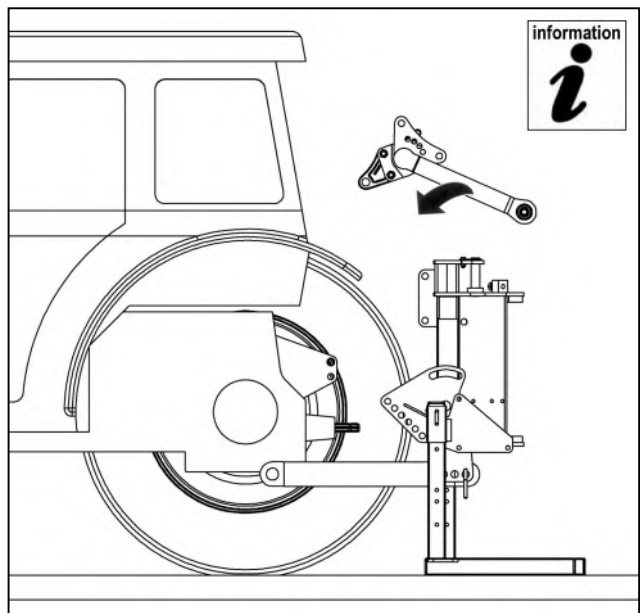

Secure top link in position using fixings provided.

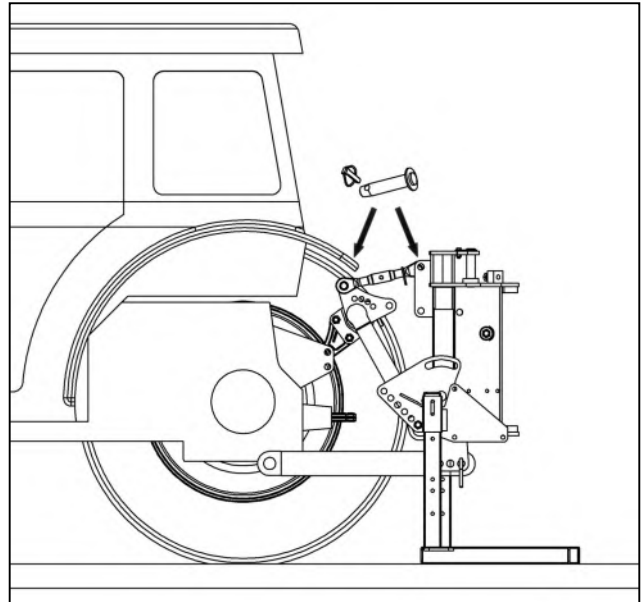

Raise the machine on the tractors linkage to a height where the tractors PTO and the stub axle of the machines gearbox are approximately in line with each other.

Note: As lift occurs be aware the machine may tilt slightly.

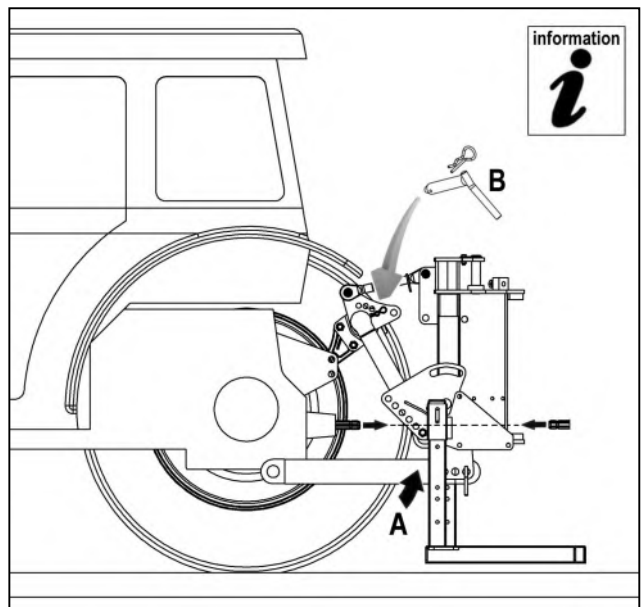

WARNING!

The quadrant lever or machine controls must only be operated from the tractor seat. Ensure no one is standing on, between, or near the linkage arms or bars during this procedure.

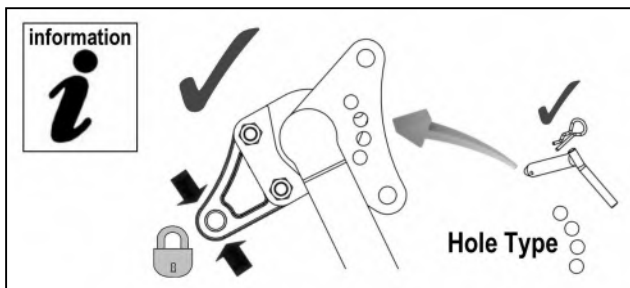

Adjust the top link to bring the machine frame into the vertical position.

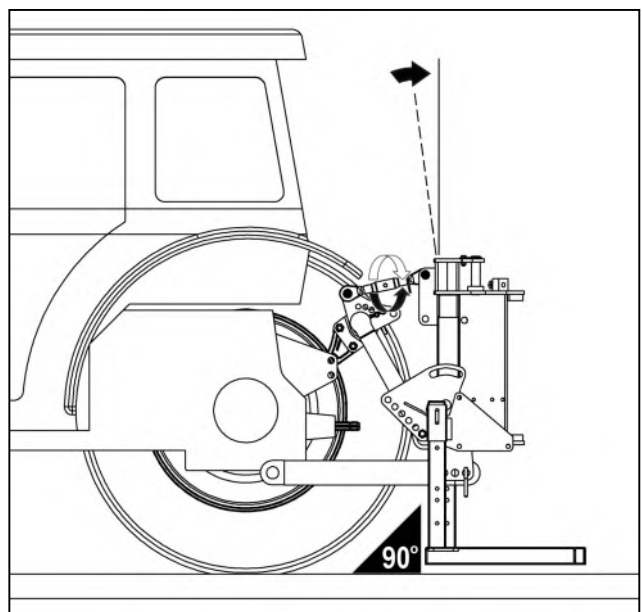
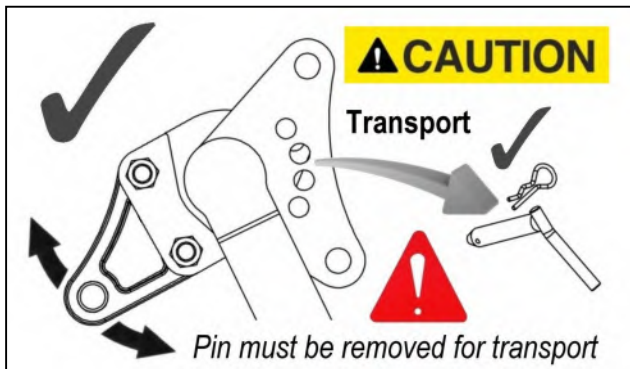

Remove leg pins and raise the stand legs to their stowage position – replace leg pins and secure in place with ‘R’ clips.

Adjust check chains to prevent sideways movement of the tractor’s linkage.

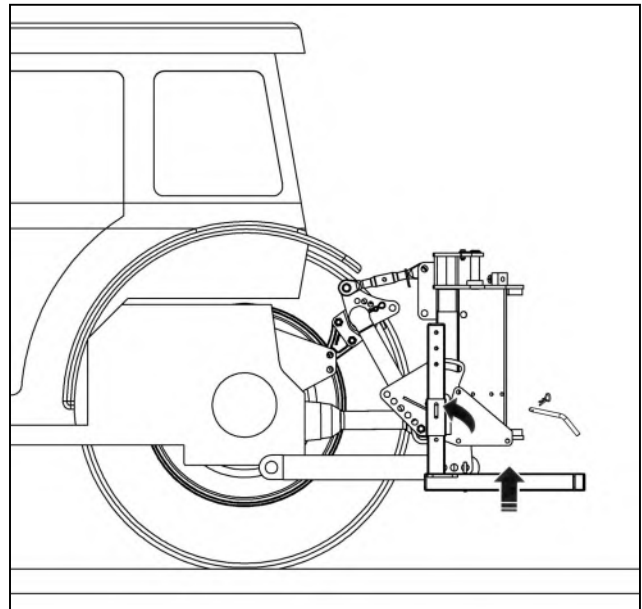

Measure the PTO shaft and cut to the dimension shown below. The finished length of the shaft should be 75mm (3") less than

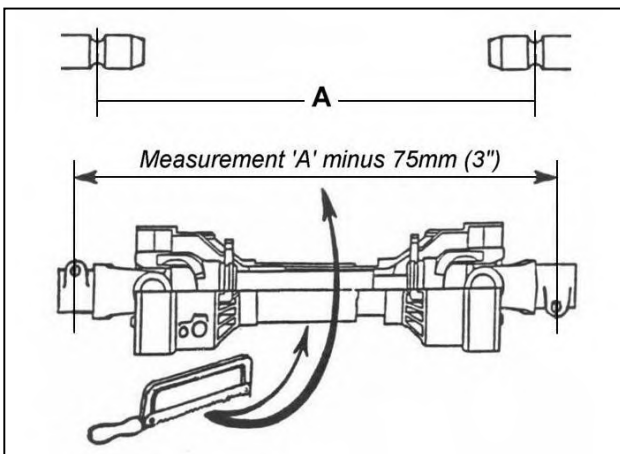

the measured distance ‘A’ between tractor shaft and gearbox stub shaft to allow for fitting. Refer to PTO installation page.

NOTE: For subsequent use with different tractors, measure again - there must be a minimum shaft overlap of 150mm (6").

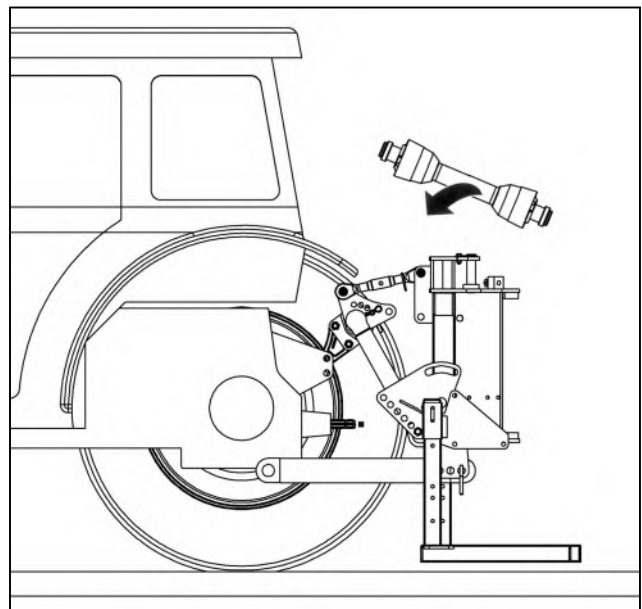

When the PTO shaft is in position attach torque chains to convenient locations to prevent rotation of the shaft guarding.

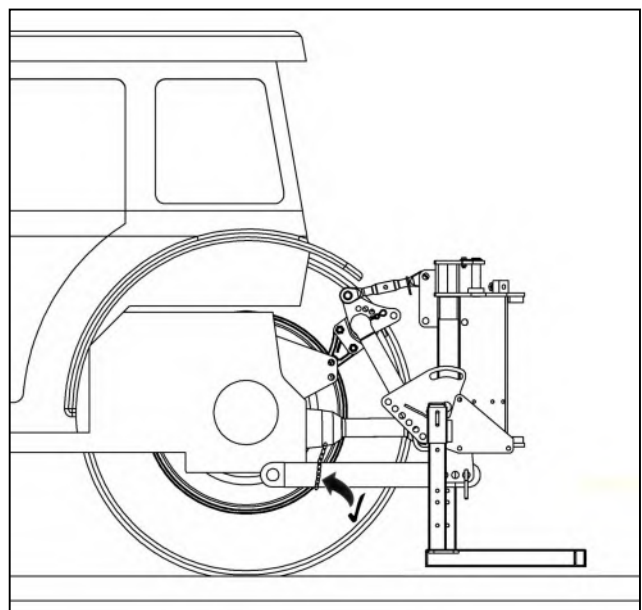

Fit the machine control unit in the tractor cab in a convenient location that allows for safe and easy operation of all the controls and functions.

PTO DRIVESHAFT INSTALLATION

The PTO driveshaft attaches between the tractor and the machine gearbox to transfer the power required to run and operate the machine – it is important to achieve the correct shaft length to avoid risk of it 'bottoming out' when raising or lowering the machine.

The procedure for measuring and cutting the shaft is as follows:

Measuring the PTO Shaft

With the machine attached to the tractor in the working position measure the horizontal distance 'A' from the tractor's PTO to the input shaft on the machines gearbox and subtract 75mm (3") – *this figure is the required shaft length.*

Place the fully closed PTO shaft on the ground and measure its overall length, if the shaft is shorter than the required length you can use it without the need to shorten - *providing it allows for a minimum 150mm (6") overlap when fitted.*

If the shaft is longer subtract the required shaft length plus an additional 75mm (3") - *the resulting figure is the excess length that will need to be removed from each half of the shaft.*

Cutting the PTO Shaft

Separate the two halves and using the measurement obtained above shorten both the plastic guarding and the inner steel profile tubes of each shaft by this same amount. De-burr the cut tubes with a file to remove rough or sharp edges and thoroughly clean to remove swarf before greasing, assembling and fitting the shaft.

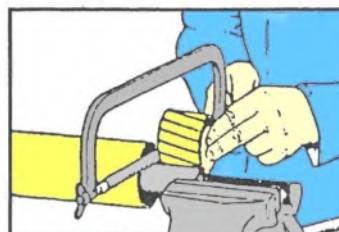
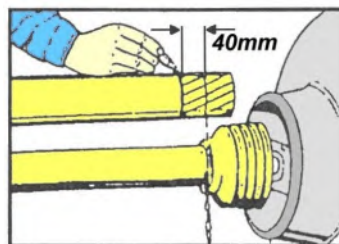
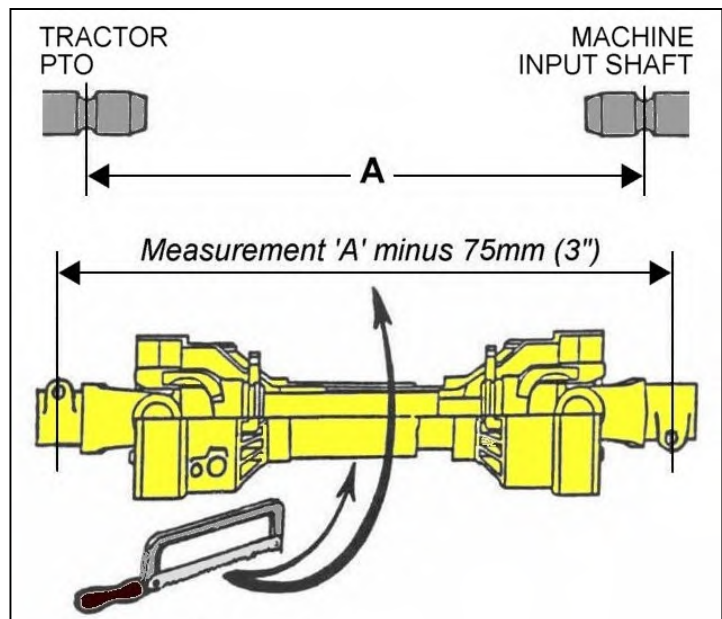

NOTE: For subsequent use with different tractors the shaft should be measured again to check suitability – *there must be a minimum shaft overlap of 150mm (6").*

Maintenance

To increase the working life of the PTO shaft it should be periodically checked, cleaned and lubricated – *refer to the PTO maintenance section for further details on this subject.*

CONTROL UNIT INSTALLATION

The information below states installation methods for fitting control units in the tractor cab.

NOTE: Electric control units work within the range of **12v-16v DC** and require a minimum power supply of **12v DC**.

Cable Controls

Cable control units are provided with, and attached to, a mounting bracket – the bracket should be securely fixed to the internal mud wing or cab cladding in a suitable convenient location that offers ease of use without interfering with normal tractor operation.

In deciding the final position of the control unit bear in mind the location of the cable run – make sure the minimum acceptable cable bend radii of 8" (200mm) is not exceeded.

Ensure during fitting that no structural member of the tractor cab or roll bar is drilled or damaged.

The cable rotor control valve lever on cable controlled machines will be assembled as a component part of the main bank of controls and therefore shares the same mounting bracket.

On electric machines with cable operated rotor control valve the lever will be supplied as a 'standalone' unit with its own individual mounting bracket – this should be fitted in the same manner as above adopting the same precautions pertaining to attachment and cable runs.

Electric Controls : Motion / Evolution

Motion and Evolution units feature an inbuilt mounting bracket for attaching the controls to the armrest of the tractor seat. An optional mounting kit (Part No. 22073.23) is available for Evolution control units if an alternative method of mounting is required.

The power supply cable should be connected directly to the tractors battery; do not use cigarette lighter type connections as these prove to be sporadic and unreliable for control applications. Control units are **12 volt DC** operated. The **brown lead is positive (+)**, the **blue lead is negative (-)**.

Electric Proportional Controls : v6 Mini-Revolution / v6 Revolution

Revolution proportional controls comprise of 2 units; the main control screen and the armrest control unit.

The control screen is supplied with a mounting bracket and suction cup assembly that allows the unit to be mounted on the window of the tractor cab; ensure the surface used is clean and dry and the unit mounted in a position where it does not obstruct operator vision.

The armrest unit is designed to slide over the armrest of the tractor seat and is held in place with the fixing straps provided. Alternately, the mounting bar of the controls can be used should a more permanent installation be required; when fitting the latter ensure that any holes drilled in the tractor cab are clear of any important components and/or electrical wiring and should not be located in any area where it could affect the safety structure of the cab or impede normal operation of machine or tractor.

The power supply cable should be connected directly to the tractors battery; do not use cigarette lighter type connections as these prove to be sporadic and unreliable for control applications. Control units are **12 volt DC** operated; the **red lead is positive (+)** and the **black lead is negative (-)**.

Operation of Control Units

Refer to the specific control manual supplied with the machine for operating instructions; users should read the controls operation manual in conjunction with the operation manual for the machine.

FLAILHEAD ATTACHMENT

For ease of attachment and safety this procedure is best performed on a firm level site. With the tractor parked alongside the flailhead operate the controls of the machine to position the pivot bracket of the machines head angling mechanism directly behind flailhead with the base of the hose tray (or junction bracket) parallel to the ground. Manoeuvre the flailhead backwards on its roller until the heads attachment bracket is adjacent to the machines pivot bracket. Fit the 4 attachment bolts through the brackets from the arm side - *if the holes are mis-aligned carefully operate the angling ram until the holes correspond.*

WARNING: Ensure all persons remain at a safe distance whilst operating the angling function as the geometry of the head angling mechanism produces several pinch risk areas.

With the attachment bolts correctly located through the brackets fit the self-locking nuts and tighten alternately until the brackets are drawn flush before finally tightening them to a torque setting of 203Nm (150ft.lbs).

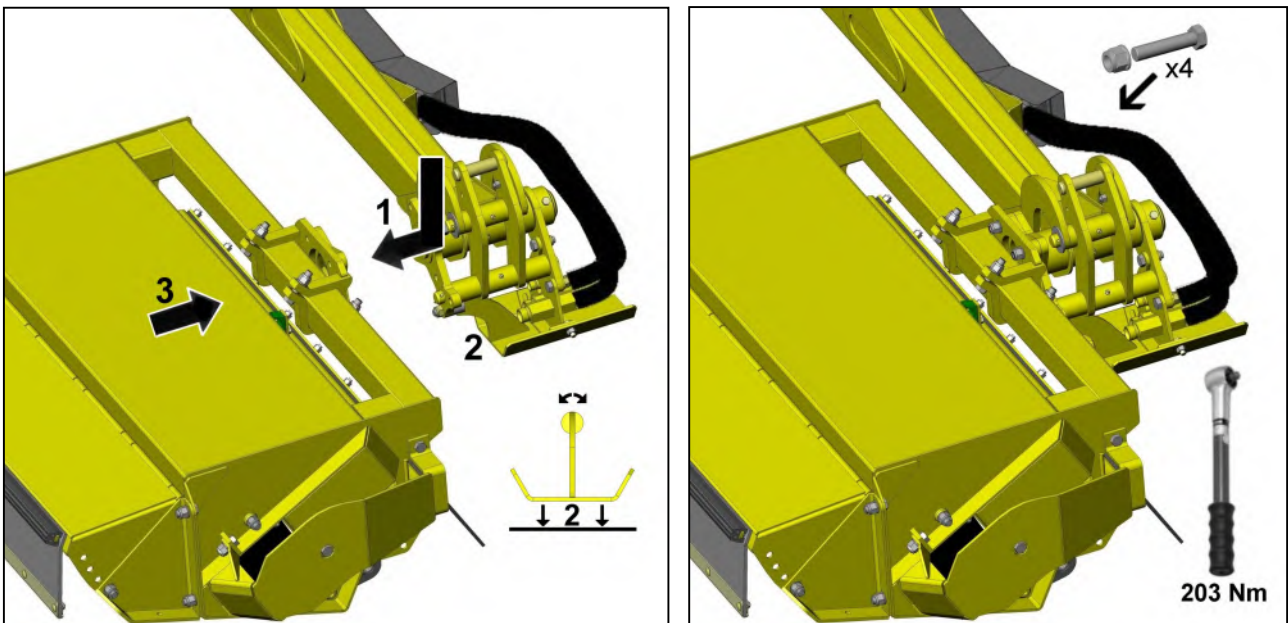

Flailhead Hose Attachment

With the flailhead attached to the machine the hydraulic hoses can now be connected – *refer to diagrams opposite.* Upper port 'A' on the motor connects to junction bracket point 'A' on the arm and lower port 'B' on the motor connects to junction bracket point 'B' on the arm.

Note: If a hose tray is already fitted to the arm it will need to be removed to allow the hoses to be connected to the junction bracket – ensure the hose tray is replaced once the hoses have been connected.

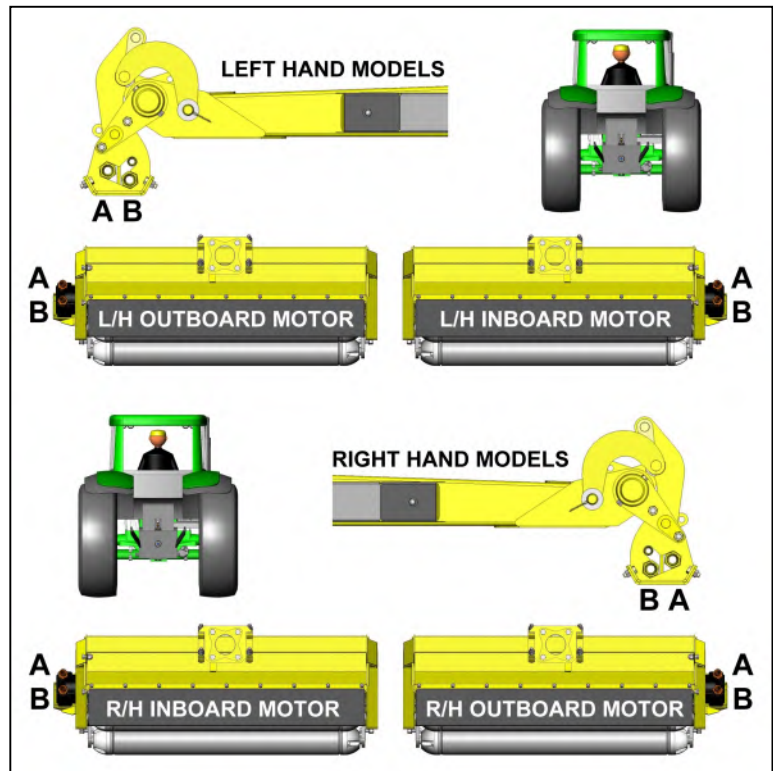

RUNNING UP PROCEDURE



CAUTION! Before initial use of a new machine, all lubrication points must be greased and the gearbox and oil tank levels checked and where required topped up before attempting to use the machine. See *maintenance section for details*.

'Running Up' the Machine

Ensure that the rotor control valve is in "STOP" position.

Start tractor, engage PTO and allow the oil to circulate through the return line filter for about 5 minutes without operation of the armhead control lever.

Operate the armhead levers through their complete range ensuring that all movements are functioning correctly.

Place the flail head at a safe attitude and move the rotor control to "START" position; after initial fluctuation the rotor should settle to a steady speed.

Increase PTO speed to approximately 360RPM and run for a further five minutes before disengaging and stopping tractor.

Check the hose runs and observe that they are free from any pinching, chaffing, straining or kinks.

Re-check the oil level in the tank-and top up as necessary.

EMERGENCY STOPPING

In all emergency situations machine operation and functions must be stopped immediately; **Stop PTO operation** using the tractor controls then immediately kill electrical power to the machine using the **Off (Emergency Stop)** switch on the machine's control unit.

WARNING: Auto-Reset Machines



When the Auto-Reset feature is active the machines arm set is capable of unintentional movement even when the PTO is switched off and stationary. Always ensure that electrical power to the machine is switched off using the **Off (Emergency Stop)** switch on the machine's control unit in emergency situations and/or when the machine is not being operated.

WARNING: Cable Operated Machines



In certain conditions, and/or if the Auto-Reset feature is active, the arm sets on cable operated machines possess the potential to move unintentionally, even when the PTO is switched off and stationary, if the levers were to be accidentally operated. Care must be adopted to avoid any movement of the levers when the machine is not being operated. Ensure arm sets are lowered fully to the ground when the machine is parked up or not in use.

PRE-WORK PREPARATION & PRECAUTIONS

IMPORTANT: Always read the book first before attempting to operate the machine – practise operating the machine, without the rotor running, in a safe open space until you are fully familiar with all controls and functions of the machine. Only begin using the machine for work when you are confident that you have mastered the controls and operation sufficient for safe use of the machine.

CAUTION: Care must always be taken when working with the flailhead close in to avoid contact with the tractor.

Pre-work Machine Checks

Prior to use of the machine always check all bolts are tight and that the torque figures are correct for the specific locations indicated below:

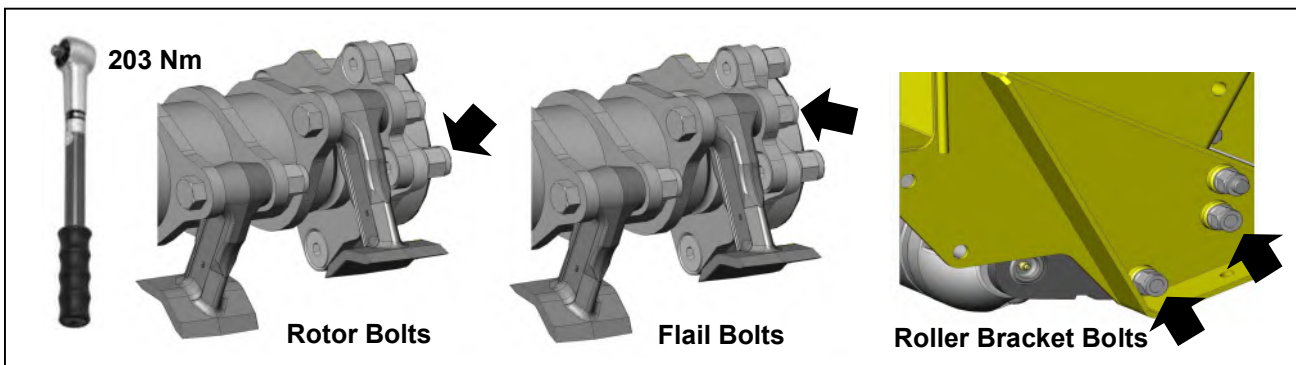
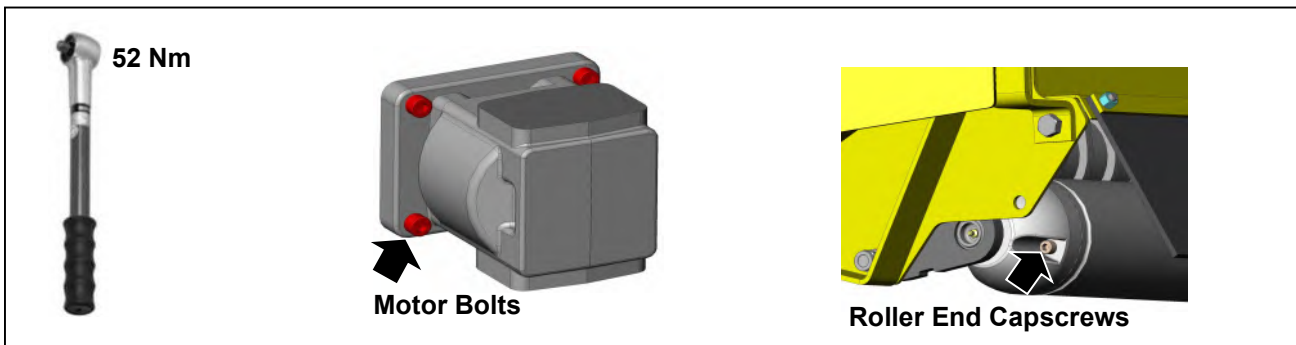

General Work Precautions

Inspect the work area prior to operation, remove any hazardous materials and note any immovable objects - *it may also be a wise precaution to mark immovable hidden hazards with a visible marker that can easily be seen from the operating position in the tractor.*

If the type of work being undertaken makes this important precaution impractical, always maintain a high degree of alertness and restrict the tractor's forward motion to a speed that allows sufficient time to stop the tractor or avoid the hazard before contact is made.

General Working Practice

It is the operator's responsibility to develop safe working procedures;

Always:

- ▲ Be aware of potential hazards in the vicinity of the work area.
- ▲ Ensure all guards are fitted correctly and in good condition.
- ▲ Disengage PTO before stopping the engine.
- ▲ Wait until the flail has stopped running before leaving the tractor seat.
- ▲ Disengage the PTO, stop the engine, remove and pocket the key before making any adjustments to the machine.
- ▲ Check frequently that all nuts and bolts are tight.
- ▲ Keep bystanders at a safe distance.

REMOVAL FROM TRACTOR

DANGER!

READ CAREFULLY BEFORE COMMENCING TO REMOVE THE MACHINE FROM THE TRACTOR.

THE ORDER OF THE FOLLOWING STEPS MUST BE FOLLOWED EXACTLY DISCONNECTING THE TOP LINK MUST BE THE LAST OPERATION PRIOR TO DRIVING THE TRACTOR AWAY FROM THE MACHINE.

WARNING!

Do not operate quadrant lever or machine controls through the rear cab window whilst standing on or amongst linkage components. **Always seek assistance.**

- Select a firm level site for parking the machine.
- Replace parking legs in their sockets and secure in their lowest position.
- Raise the machine on the tractor linkage until the weight is taken off the stabiliser.
- Remove the lower stabiliser pins.
- Unscrew the lift ram tap.
- Lower the machine to be ground.
- Extend the arms and place the flail head on the ground at half reach.
- Disengage tractor PTO and remove.
- Disconnect stabiliser bars and/or loosen check chains as applicable.
- Remove control unit from tractor cab and stow in a safe location clear of the ground.
- Disconnect the stabiliser from the tractors top hitch position.
- Remove draft link pins and carefully drive tractor clear of the machine.

STORAGE

If machine is to be left standing for an extended period of time, lightly coat the exposed portions of the ram rods with grease. Subsequently, this grease should be wiped off before the rams are next moved.

If the machine has to be stored outside tie a piece of tarpaulin or canvas over the control assembly, do not use a plastic fertilizer bag which could lead to rapid corrosion.

OPERATION

Operator Guard

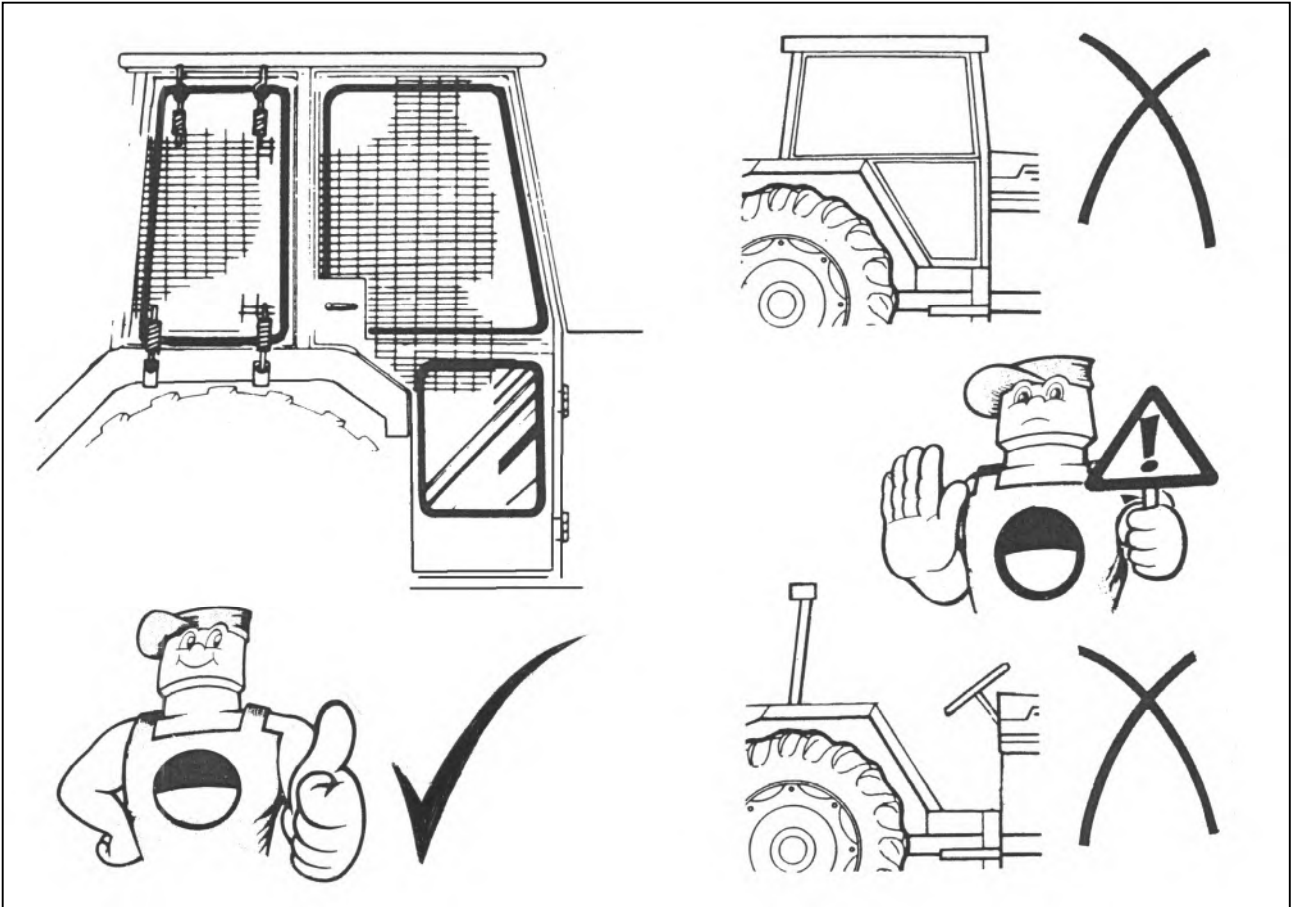

Machine Guards

Before each period of work, check that all the relevant tractor and machine guards are in place and in good working condition.

Small splits and abrasions on the lower edges of the flail head rubber flaps are permissible, but should one or more of these cuts or splits become fifty per cent or more of the flap height they should be replaced immediately as they will have become ineffective for debris containment.

Operator Safety

During operation all the tractor windows should be kept firmly closed with the exception of the rear window which may be opened only to the extent that is sufficient to allow entry of electrical or operating cables for the machine into the cab.

Should the tractor not be fitted with a 'quiet' cab ear defenders must be worn at all times, failure to heed this warning may result in permanent damage to hearing.

Although in normal circumstances a working machine or rotating parts should never be approached it is an additional wise precaution to avoid wearing loose or flapping clothes especially scarves and neckties whilst in close proximity to a machine.

The operator should continually guard himself and others from complacency that can arise from familiarity. Never attempt to take 'short cuts', always follow the correct procedures diligently and abide by the restrictions imposed by safety considerations.

REMEMBER: there is only one right way - the safe way!

OPERATOR CONTROL SYSTEMS

Control System Operation Manual

For electrically controlled machines a dedicated operation manual for the specific control unit shipped with the machine is issued alongside this manual; **the control unit operation manual supplied must be read in conjunction with this manual** and should ideally be kept in the tractor cab for reference by the operator.

Control Unit Identification

Depending on specification the machine will be operated by one of the following controls;



Users of this machine must read the specific control unit operation manual supplied with the machine in conjunction with this manual.

Control unit operation manuals are also available on our website for reference or download at; <https://www.mcconnel.com/support/parts-and-operators-manual/> or via QR code below.



CABLE CONTROLS

Cable controlled machines are supplied with a control unit of the type shown below – the particular version will be dependent on the specification and features of the machine. Versions differ primarily in the number of armhead control levers assembled within the control bank – some versions will have the rotor control lever assembled alongside the armhead control levers as shown below left and others will be supplied with the rotor control lever as a ‘standalone’ unit with its own individual mounting bracket.

The armhead control levers all move in a forwards and backwards direction each controlling a specific arm function with the exception of the auto reset lever which operates only in the backward direction (from central ‘off’ position to the backwards ‘on’ position).

Where applicable, if a machine is fitted with the optional lift float feature, operation of the lift float will be via an additional electrical switch which will need to be installed in a convenient location in the tractor cab.



Basic Cable Control Unit



Cable Control Unit with Auto Reset

LOCATION & FUNCTION OF CONTROLS

1. Arm Lift Control
2. Arm Reach Control
3. Head Angle Control / Angle Float Selection
4. Arm Slew Control
5. Rotor Control
6. Auto Reset (*where applicable*)
7. Midcut/VFR (*where applicable*)



Cable Control Unit with Auto Reset & Midcut

NOTE: The illustrations on the following pages show the method of operating all possible functions – depending on individual specifications some features may not be present on your particular machine and therefore will not be applicable.

ARM OPERATION

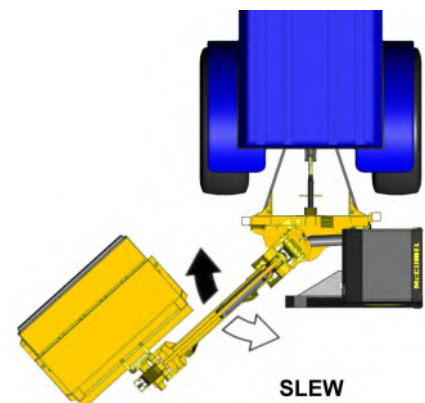
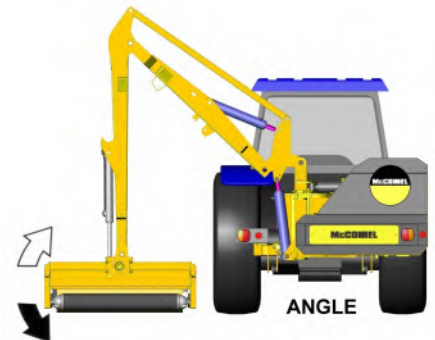
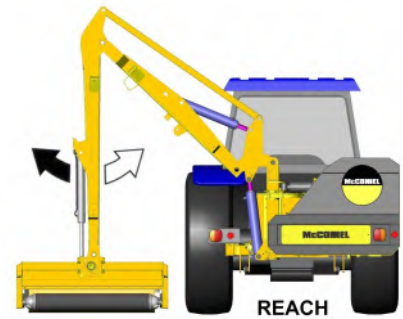
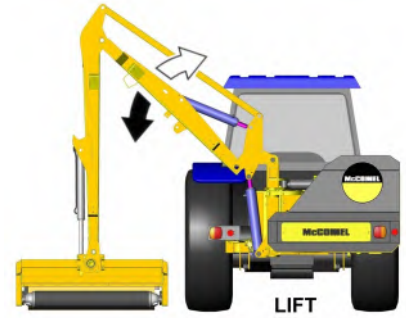

Rotor Control

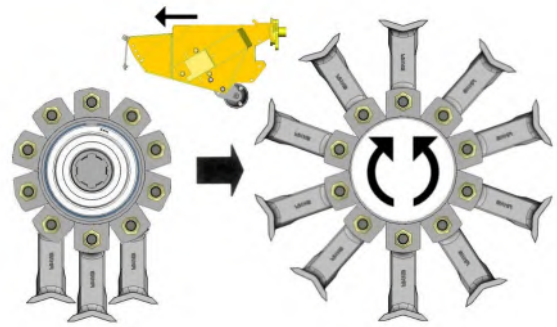

Refer to specific cable rotor control section for additional information on rotor operation

Midcut/VFR Models

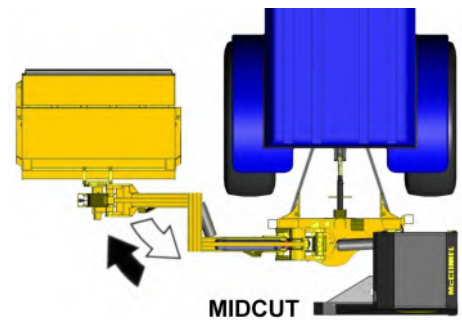

MIDCUT

FLOAT OPERATION (Angle Float standard/ Lift Float optional)



HEAD ANGLE FLOAT -
Push angle lever fully forward into the detent position.

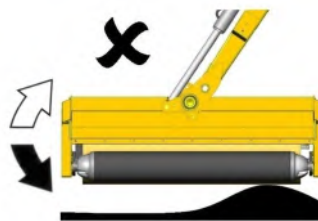

A) Angle Float OFF



B) Angle Float ON

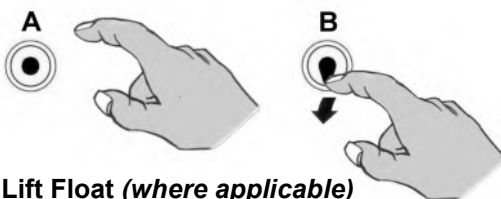

Lift Float (where applicable)

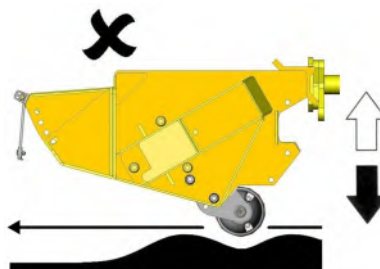

A) Lift Float OFF

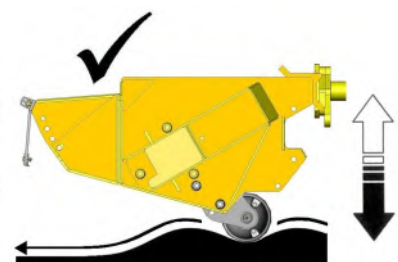

B) Lift Float ON

CABLE ROTOR CONTROL

On cable rotor control machines the rotor is operated by the lever shown below – from the upright 'off' position pushing the lever forward switches the rotor on for downhill cutting and pulling the lever backwards switches the rotor on for uphill cutting. The small pivot locking lever mounted on the side of the control assembly rotates through 180° to lock the rotor in a specific cutting direction – this is a safety feature to avoid changes of rotor direction without first stopping the rotor. To change the direction of cut the rotor lever must be placed in the upright 'off' position; when the rotor has stopped rotating completely the pivot locking lever can be turned to the opposing position allowing the control lever to be operated for opposite cutting direction.

On some cable operated machines the rotor control lever will be assembled as part of the main bank of controls, whereas on others and all electric models it will be supplied as a 'standalone' unit with its own mounting bracket.

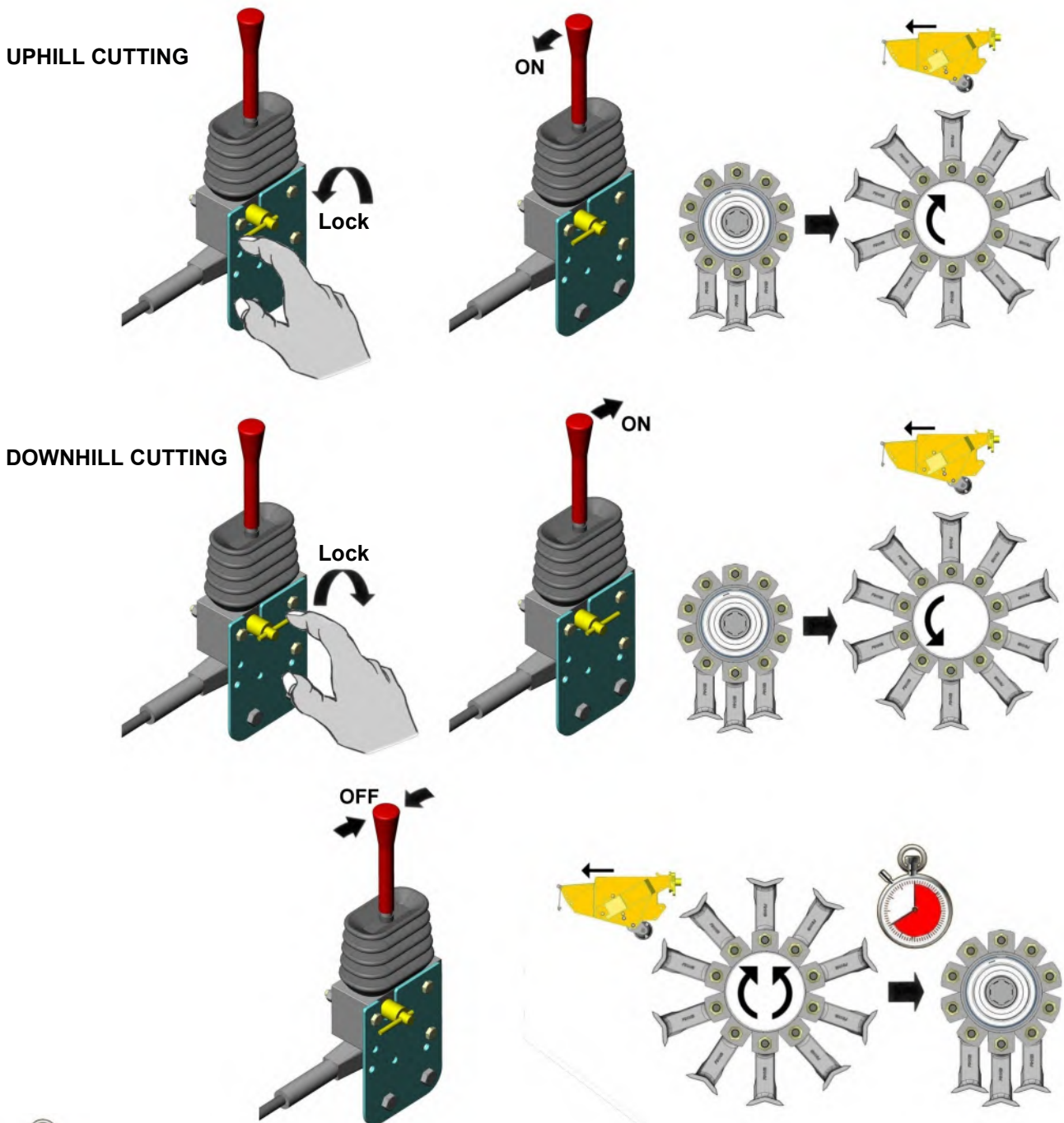

CAUTION: Ensure the rotor has stopped turning completely before attempting to change direction - When switched off a rotor can continue to 'freewheel' under its own momentum for up to 40 seconds before stopping.

SLEW & LIFT LOCKS

Slew Ram Lock

The machine is fitted with a slew ram lock as shown opposite. The slew function must be 'locked' at all times during transportation and storage of the machine and only unlocked for work.

SLEW RAM LOCK ►
Open – *only for working*
Closed – *always for transport & storage*

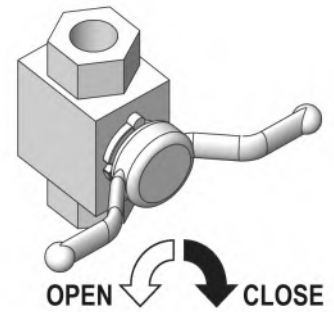

Lift Ram Lock

The machine is fitted a lift ram lock tap - the tap should always be closed during transport and storage of the machine to prevent any movement of the arms during transportation or when the machine is parked up. The tap lock will be similar to the one illustrated opposite.

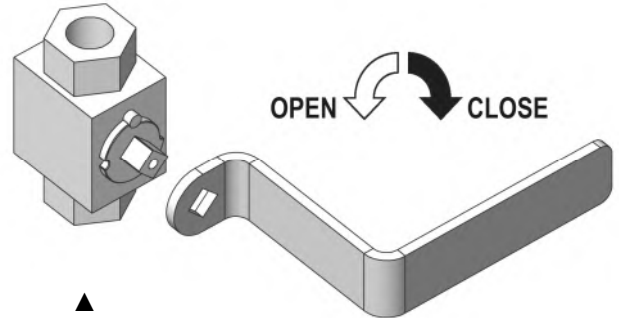

▲ LIFT RAM LOCK TAP
Open – *only for working*
Closed – *always for transport & storage*

CAUTION!



Slew and Lift Locks must be in the closed / locked position at all times during machine transportation and storage – open / unlock only for work.

BREAKAWAY

The machine is fitted with a hydraulic breakaway device which protects the structure of the machine should an unforeseen obstacle be encountered.

NOTE

The breakaway function does not relieve the operator of his responsibility to drive carefully, be alert and avoid obvious hazards before contact occurs.

Breakaway may occur momentarily during normal work should an extra thick or dense patch of vegetation be encountered. In these instances tractor forward motion may be maintained with care.

Where breakaway has occurred as a result of contacting a post or tree etc. the tractor must be halted and the controls of the machine utilised to manoeuvre the head away from the obstacle. **Never continue forward motion to drag the head around the obstacle in breakback position.**

NOTE

The force required to activate the breakaway system will vary dependent upon the gradient of work. It will require less force when working uphill and vice versa.

On mid-cut machines the geometry of the breakaway will cause the head to initially move outwards in addition to rearwards. Therefore be aware that the breakaway action will be impeded if the outer end of the head is working against a steep bank. In this circumstance extra care must be taken during operation to avoid this occurrence.

Breakaway occurs at the slew column pivot. When an obstacle is encountered continued forward motion causes the pressure in the slew ram base to rise until the relief valve setting is exceeded.

With 'Auto Reset' selected:

When the slew relief valve setting is exceeded oil is displaced from the slew ram into the base of the lift ram which causes the head to rise as the arm pivots backwards to clear the obstruction.

Resetting of the head into the work position occurs automatically.

With 'Slew' selected:

When the slew relief valve setting is exceeded oil is displaced from the slew ram allowing the arm to pivot backwards horizontally and the obstacle to be cleared.

Re-setting the head into the work position is carried out manually by selecting 'Slew Out' on the control assembly

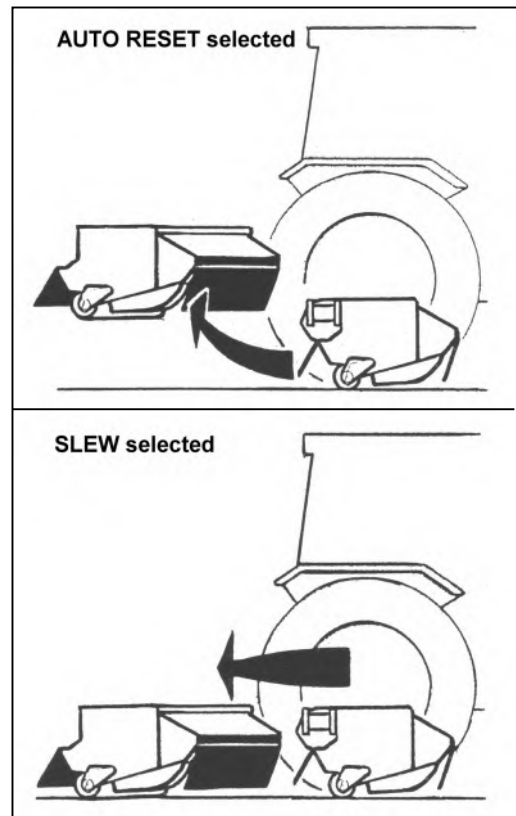

POWERED SLEW

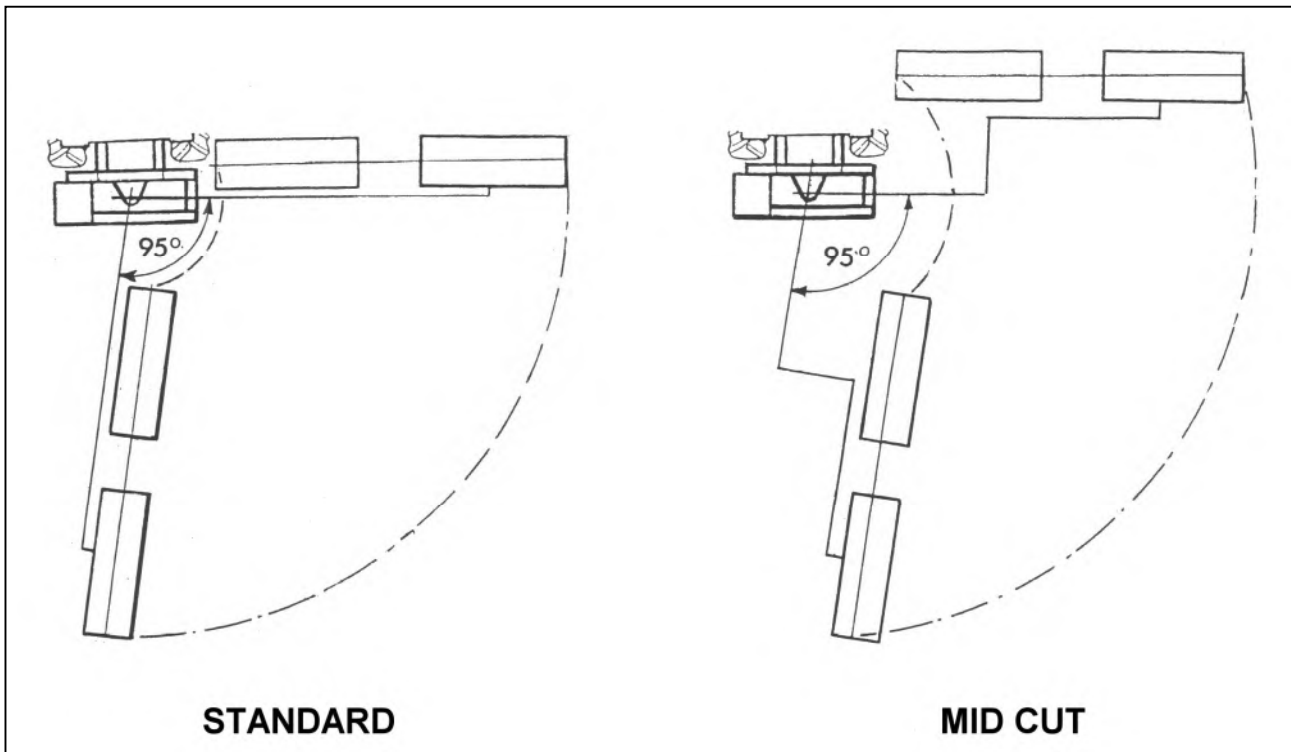

The slew feature allows a 95° arc of powered arm movement on the working side from right angles to the tractor to 5° beyond the direct line astern.

The feature is required to place the machine in the transport position but can also be used to sweep the arm to and fro whilst cutting awkward areas and corners thus avoiding the need to constantly re-position the tractor. To operate in this way 'Slew' must be selected on the control assembly.

If breakaway occurs the slew motion must be reversed to allow the slew breakaway relief valve to re seat and the ram to become operable again.

CAUTION

Extra care must be taken when working in 'SLEW' mode with the reach fully in – IT IS POSSIBLE FOR THE FLAILHEAD TO HIT THE TRACTOR OR MACHINE FRAME.

WIRE TRAP

The flail head is equipped with a wire cutting edge welded into the underside. This is to ensure that the ends of any wire that may be entwined in the rotor are cut and fall within the confines of the flail head. **This plate should not be interfered with in any way.**

Any wire caught in the rotor must be immediately removed (*see below*).

Removing Wire

- Select rotor 'OFF' and wait until it has **stopped rotating**.
- **STOP** the tractor and only then remove wire.

Do not reverse the rotor in an attempt to unwind any wire.

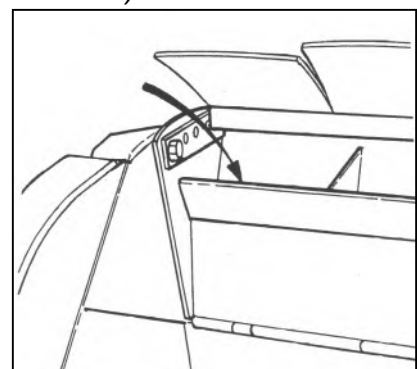

MOVING INTO TRANSPORT POSITION

Select 'Rotor Off' and wait for the rotor to stop turning completely.

Ensure that both 'lift' and 'angle float' functions are switched off.

Select 'slew' mode on the controls.

Operate 'slew in' function to bring the arms into position directly behind the tractor.

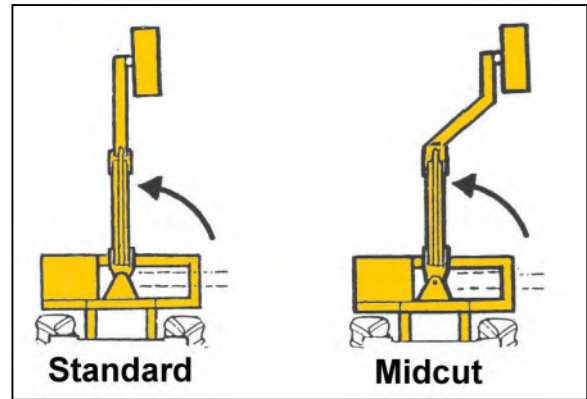

Operate 'lift' and 'reach' to position the as shown in the diagram opposite.

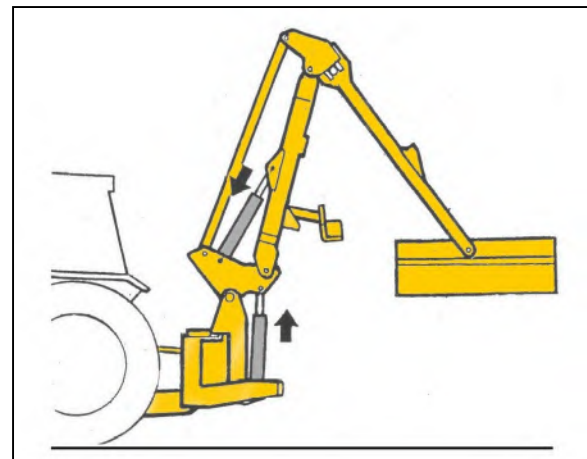

Place transport prop into the transport position



Work Position



Transport Position

Operate 'reach in' until the dipper arm contacts the transport prop.

Select 'lift up' and raise the arms until the tension link is 300mm (12") from the tractor cab.

Operate 'angle' to move the flailhead into a position where it is as compact as possible.

Close lift ram tap.

Close slew ram tap.

Disengage the PTO shaft

Ensure power to the control unit is switched off.

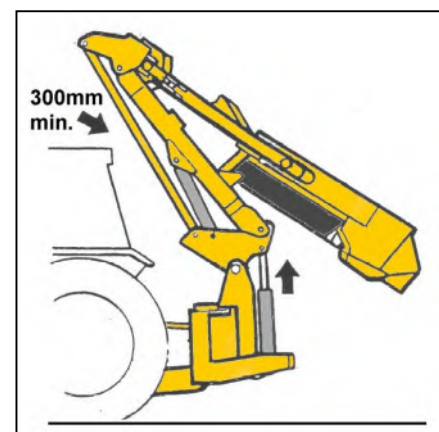
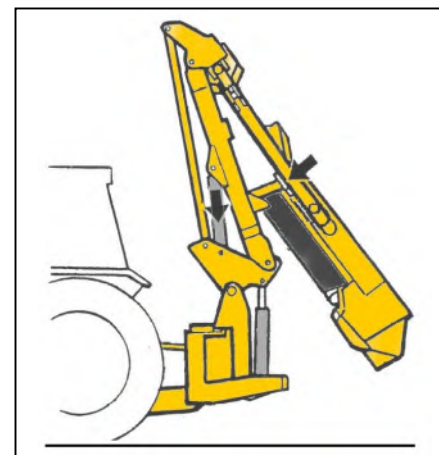

See following page for additional information regarding transport positions.

TRANSPORT POSITION FOR REAR MOUNTED MACHINES

The machine is transported inline to the rear of the tractor with a minimum of 300mm (12") clearance between the tension link and the rear cross member of the tractor cab.

Transport Position with Flailhead Attached

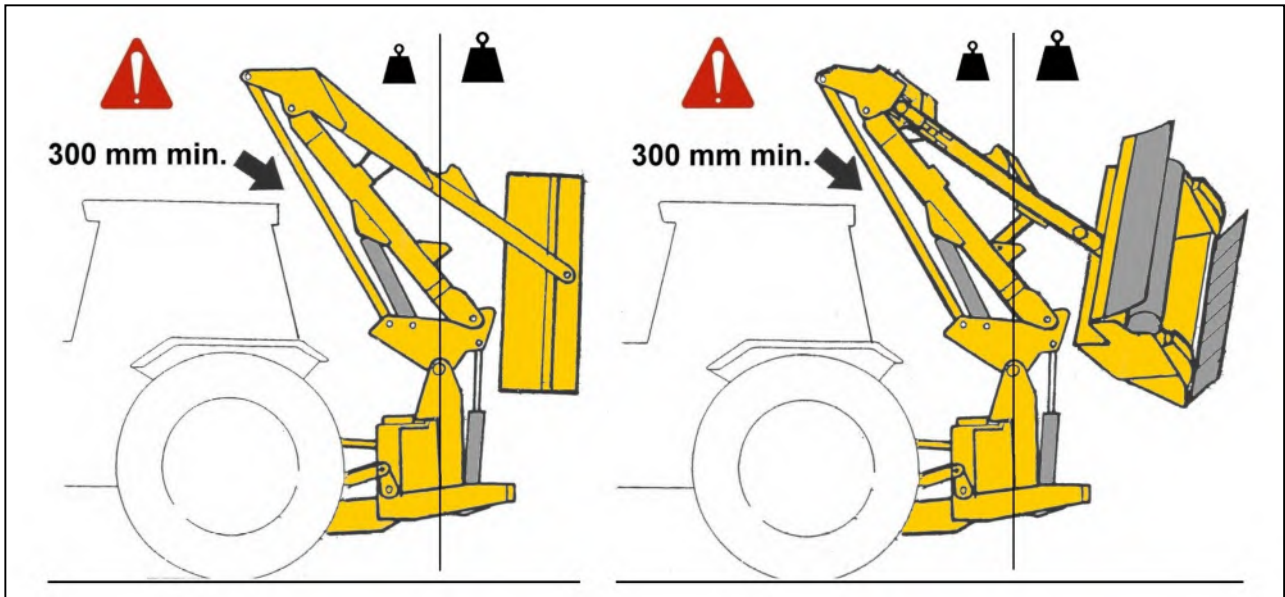

Transport Position with Flailhead Removed

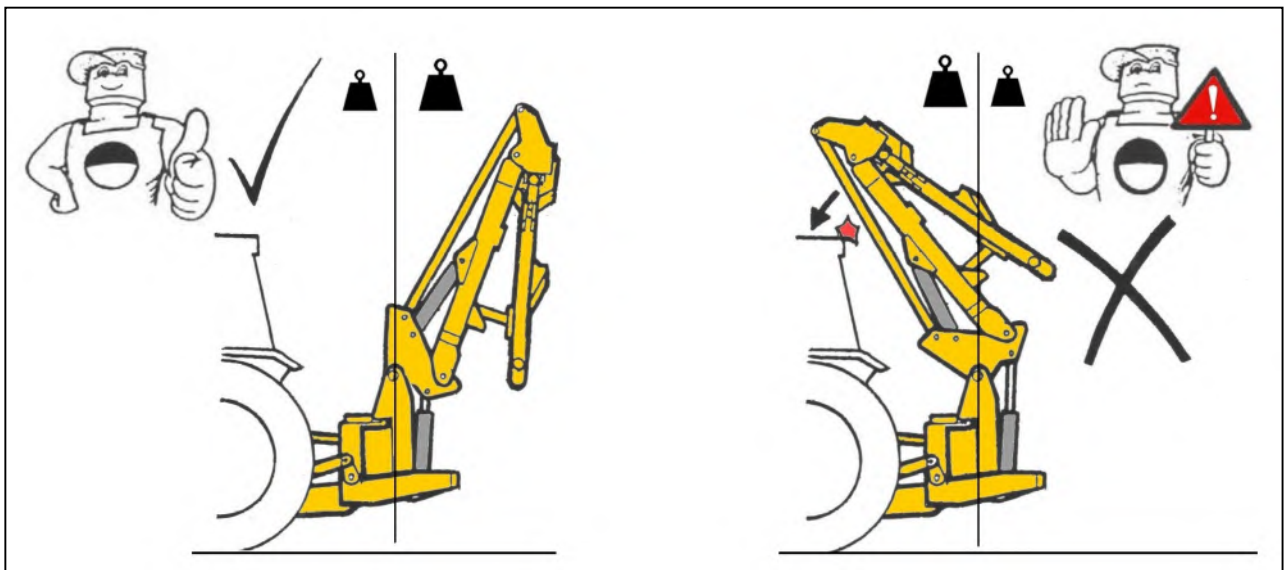

For transportation without a flailhead attached, the machines arms must be fully folded and the lift ram fully retracted so the mass of the arms is behind the centre line – If the lift ram was extended the weight of the arms would be in front of the centre line which would result in the balance of the machine going 'over centre' causing the tension link to crash into the rear cross member of the tractor's cab.

WARNING: During transport the 'SLEW' mode must ALWAYS be selected on the controls.

TRANSPORTING THE MACHINE

Transport Height

There is no fixed dimension for the transport height as this will vary for differing applications i.e. tractor size, carrying height, and degree of arm fold the particular tractor cab will permit. For the majority of installations the transport height will be in the region of approximately 3.45m to 3.65m.

It is advisable that once your machine has been installed on the tractor that it is folded into the transport position and your own measurement taken to ensure you have an accurate figure for the transport height.

CAUTION: Always be aware of the transport height of your machine and proceed with care when manoeuvring near building, bridges and all other overhead obstructions.

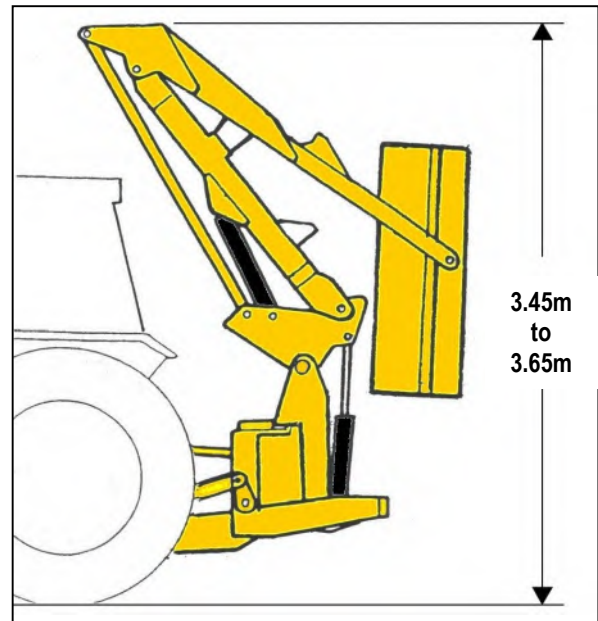

Approximate transport height

Transport Speed

The acceptable speed of transport will vary greatly depending upon the ground conditions. In any conditions avoid driving at a speed which causes exaggerated bouncing as this will put unnecessary strain on the tractors top hitch position and increase the likelihood of the tension link coming into contact with the cab rear cross member.

WARNING: During transportation of the machine the PTO must be disengaged and power to the controls switched off.

CAUTION On machines equipped with multi-hole type stabilizers it is vital that the stabilizer position pin is always removed for machine transport and only fitted for work; failure to observe this can result in serious damage to machine and/or tractor components.

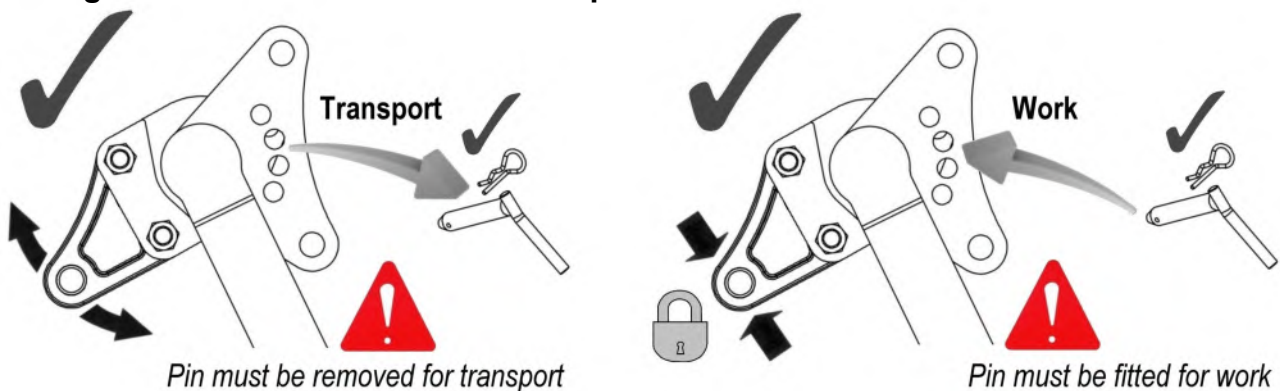

MOVING FROM TRANSPORT TO WORK

Reverting to the work position is basically a reversal of the previous work to transport procedure.

NOTE: Remember to release the slew ram and lift ram locks before attempting to move the machine from the transport position.

Engaging Drive

Ensure that the rotor control lever is in the 'Stop' position before engaging the PTO shaft. Allow the oil to circulate for a minute or so before operating the armhead levers. Position the flail head in a safe position, increase the engine speed to a high idle and move rotor control lever to 'Start'. After initial surging the rotor will run at an even speed.

OPERATING SPEEDS

PTO Operating Speed

The correct PTO speeds for operation of machines is: **500 - 540 rpm (Max)**

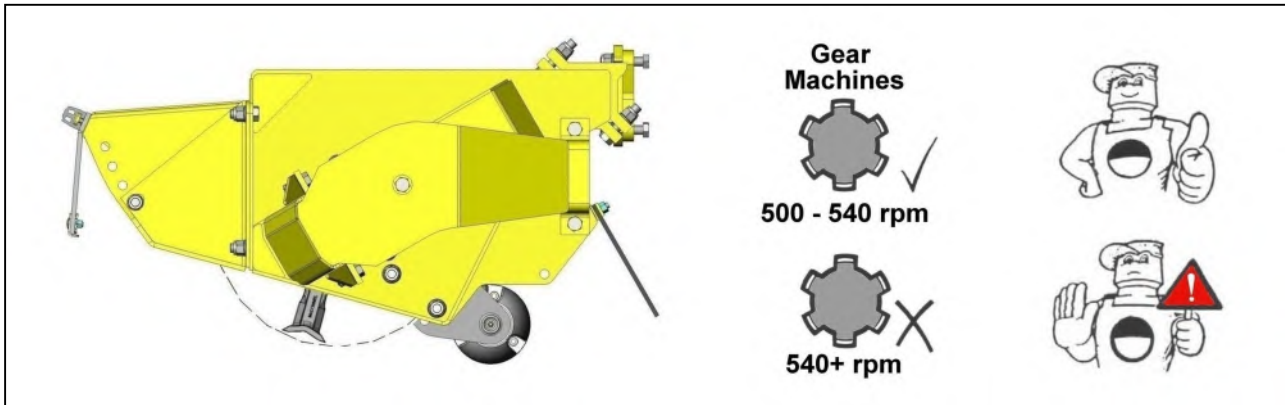

WARNING: Damage to the machine may occur if the maximum PTO speed is exceeded.

Engaging Drive

- Ensure the rotor control lever/switch is in the 'stop' position before engaging the PTO.
- Allow the oil to circulate for a minute or so before operating the armhead controls.
- Move the flail head into a safe working position just clear of the material to be cut.
- Increase engine speed to a high idle and start the rotor – *after initial surging the rotor will run at an even speed.*
- Carefully lower the flail head into the work area and begin work.

Tractor Forward Speed

The material being cut will determine the tractor forward speed. Forward speed can be as fast as that which allows the flail head sufficient time to cut the vegetation both efficiently and neatly.

If forward speed is too fast this can be indicated by over frequent operation of the breakaway system, a fall off in tractor revs and a poor untidy finish to the work leaving ragged uncut tufts and poorly mulched cuttings.

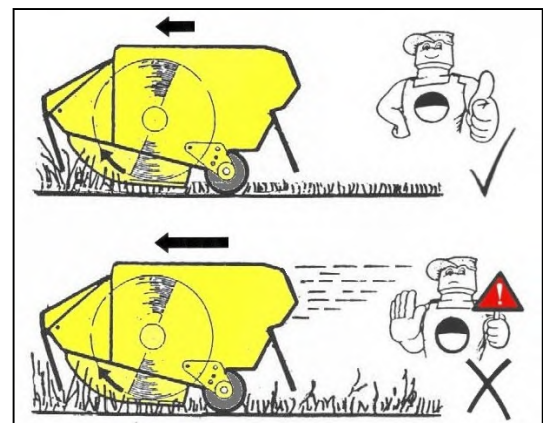

'Running In' a New Machine

For the first days work with a new machine it is recommended that tractor forward speed is restricted to 3 km/hr (2 mph) maximum. This will allow machine components 'bed in' and allow the operator to become familiar with the controls and their response under working conditions whilst operating at a relatively slow speed. If possible, select a first days work that affords mainly light to average cutting with occasional heavy duty work – *during this period check the tightness of nuts and bolts every hour, retightening as and when required.*

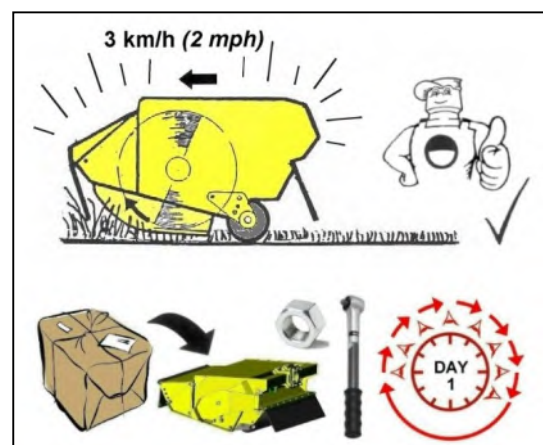

HAZARDS & DANGERS

Adverse Slopes

When working with the flailhead high and reach fully in it is possible for the main arm balance to go over centre and take the weight off the lift ram. A restrictor in the gland circuit of the lift ram will prevent sudden unpredictable movements if this should occur - *for reasons of safety this restrictor should not be removed.*

DANGER!



NEVER REMOVE THE RESTRICTOR FROM THE LIFT RAM GLAND CIRCUIT.

Never work the machine on adverse slopes with the arms positioned such that the tractor is unbalanced ►

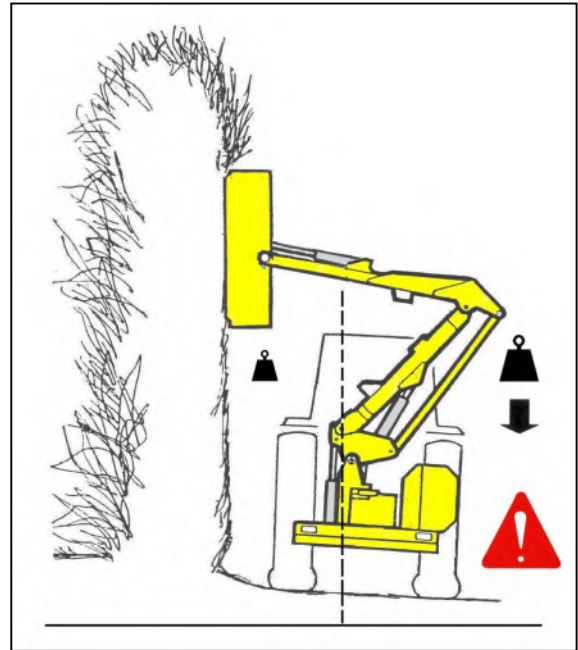

DANGER!



NEVER CUT TO THE BLIND SIDE OF A HEDGE
- it is impossible to see any potential hazards or dangers and the position of the flail head would allow debris to be propelled through the hedge towards the tractor and operator.

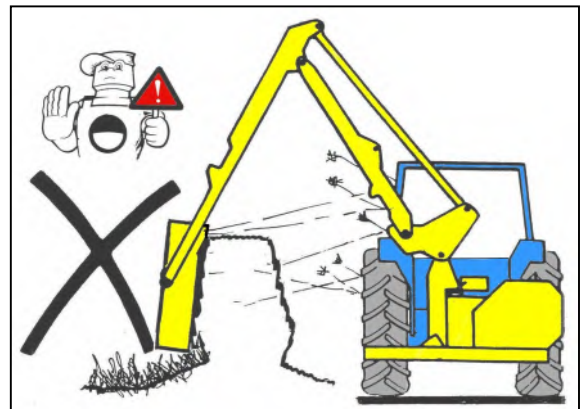

DANGER!



NEVER OPERATE THE MACHINE WITH THE FLAIL HEAD ROLLER REMOVED

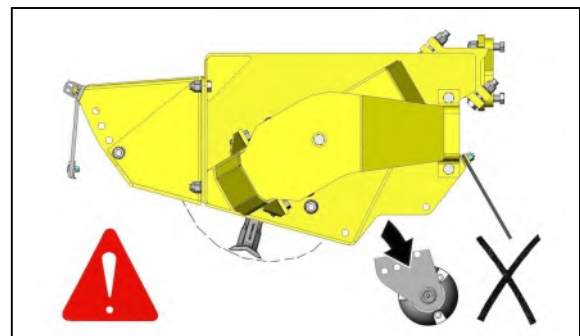

DANGER!



WHEN GRASS MOWING THE ROTOR MUST ALWAYS CUT IN THE UPHILL DIRECTION WITH FRONT HOOD FITTED AND THE ROLLER POSITIONED BELOW THE CUTTING HEIGHT OF THE FLAILS

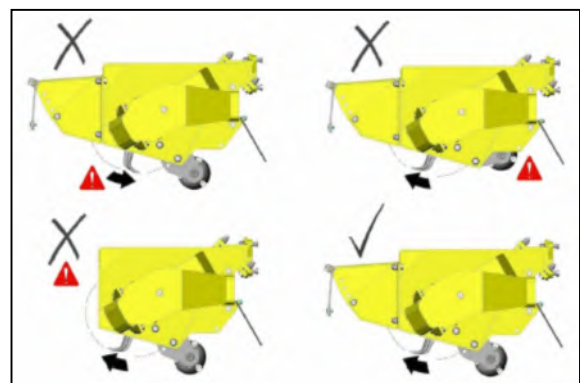

OVERHEAD POWER LINES (OHPLs)

It cannot be stressed enough the dangers involved when working in the vicinity of Overhead Power Lines (OHPLs). Some of our machines are capable of reach in excess of 8 metres (26'); they have the potential to well exceed, by possibly 3 metres (9' 9"), the lowest legal minimum height of 5.2 metres from the ground for 11,000 and 33,000 volt power lines.

Remember electrocution can occur without actually coming into contact with a power line as electricity can 'flashover' when machinery gets close to it.



WARNING: All operators must read the following information and be aware of the risks and dangers involved when working in the vicinity of Overhead Power Lines (OHPLs).

Wherever possible the safest option is always to avoid working in areas close to OHPLs. Where unavoidable, all operators must perform a risk assessment and implement a safe procedure and system of work – see *following page for details*.

All operators should perform a risk assessment before operating the machine within 10m horizontal distance of any OHPLs.

Minimum Heights for Overhead Power Lines

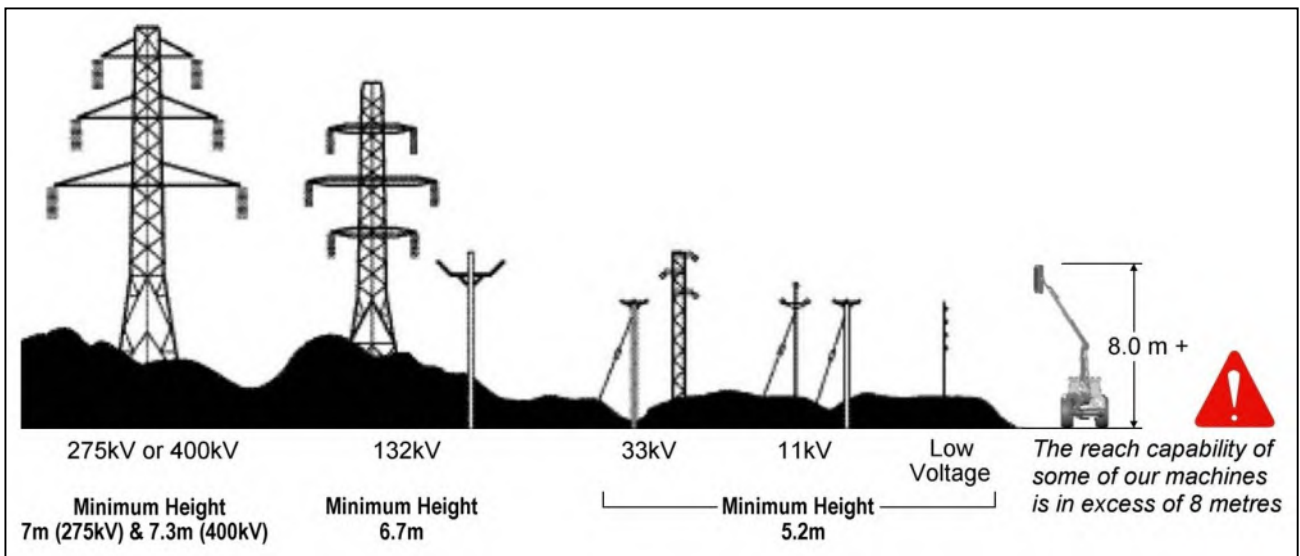

Absolute Minimum Exclusion Zones for Specific Overhead Power Lines

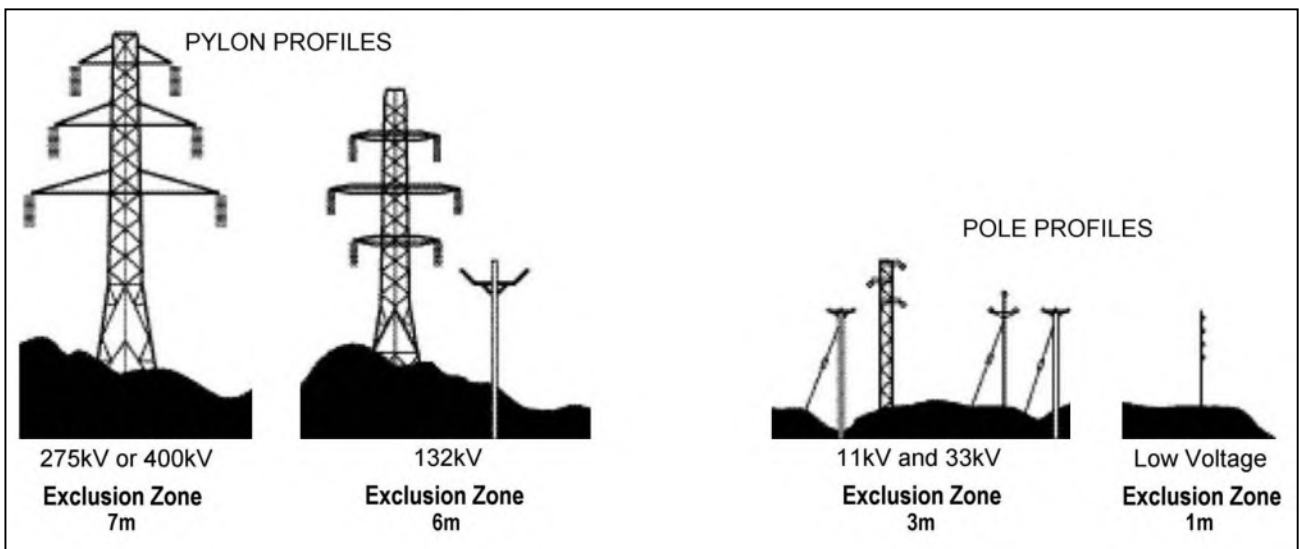

Definitions of Exclusion Zones

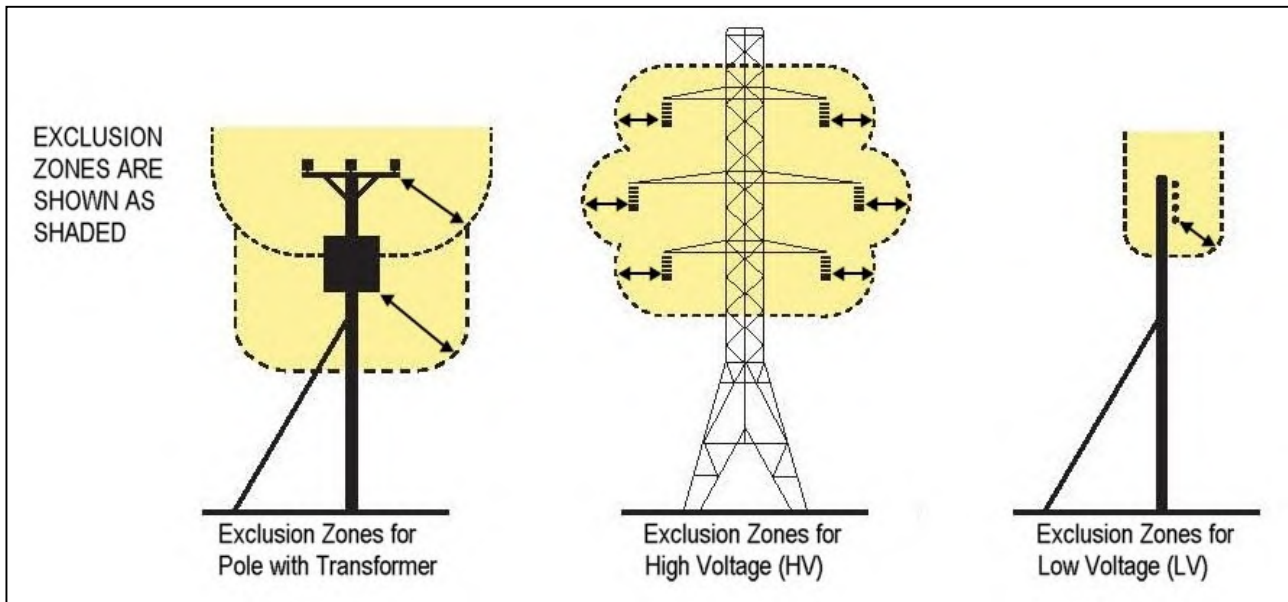

Risk Assessment

Before starting to work near OHPLs you should always assess the risks. The following points should be observed;

- **Know** the risks of contacting OHPLs and the risk of flashover.
- **Find out** the maximum height and maximum vertical reach of your machine.
- **Find out** the location and route of all Power Lines within the work area.
- **Find out** the operating voltage of all Power Lines within the work area.
- **Contact** the local Distribution Network Operator (DNO) who will be able to advise you on the operating voltage, safe minimum clearance distance for working, and additional precautions required.
- **Never** attempt to operate the machine in exclusion zones.
- **Always** work with extreme caution and plan your work ahead to avoid high risk areas.
- **If doubt exists** do not work in the area – never risk the safety of yourself or others.

Emergency Action for Accidents Involving Electricity

- Never touch an overhead line - even if it has been brought down by machinery, or has fallen. Never assume lines are dead.
- When a machine is in contact with an overhead line, electrocution is possible if anyone touches both the machine and the ground. Stay in the machine and lower any raised parts in contact or drive the machine out of the lines if you can.
- If you need to get out to summon help or because of fire, jump out as far as you can without touching any wires or the machine - keep upright and away.
- Get the electricity company to disconnect the supply. Even if the line appears dead, do not touch it - automatic switching may reconnect the power.

Further information and leaflets on this and other agricultural safety subjects are available on the 'Health & Safety Executive' website at the following address: www.hse.gov.uk/pubns/agindex.htm

HEDGECUTTING PROCEDURE

Cut the side and bottom of the field side first. This leaves the maximum thickness of hedge on the road side to prevent the possibility of any debris being thrown through the hedge into the path of oncoming vehicles.

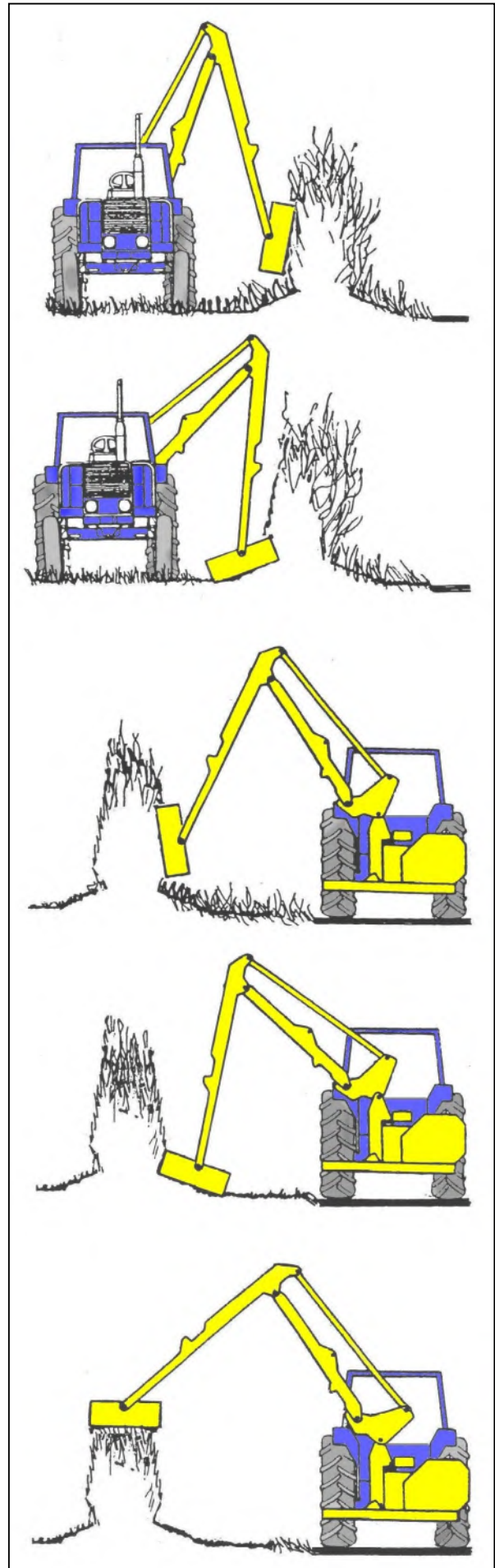

Cut the side and bottom of the road side.

Top cut the hedge to the height required.

LIFT FLOAT (Optional Extra for Ground Work)

Work without lift float requires far more concentration and input from the operator to quickly react and re-adjust to the ground contours often resulting in patches of higher cut material where the head is cutting too high and 'scalping' of the ground where it is cutting too low – *in the case of the latter this can lead to increased flail wear, damage or even loss of flails.*

The Lift float feature is an optional extra for use during mowing work. When the function is activated the pressurised accumulator(s) work in conjunction with the valve and lift ram to take a proportion of the flailheads weight off the flail roller allowing the head to automatically follow the natural contours of the ground; this produces a cleaner more uniform cut without the need for constant operator re-adjustment. On EDS models the function has 3 user settings for differing working conditions – these are soft, medium and hard. *Refer to the relevant control section for details of selecting the required setting.*

Operation of the lift float function is as follows: with lift float switched off, position the flailhead approximately 1m clear of the ground before switching the float function on to charge the accumulator(s) – *the arms may drop at this point depending on the current level of retained pressure.* Lower the flailhead into the work position, release the lift control and proceed to work. **NOTE: with the exception of EDS models, occasional operation of the lift function will be required when working on downhill or uphill slopes and when reaching in or out in order to replenish the oil level within the accumulator(s) to retain optimum float capability.**

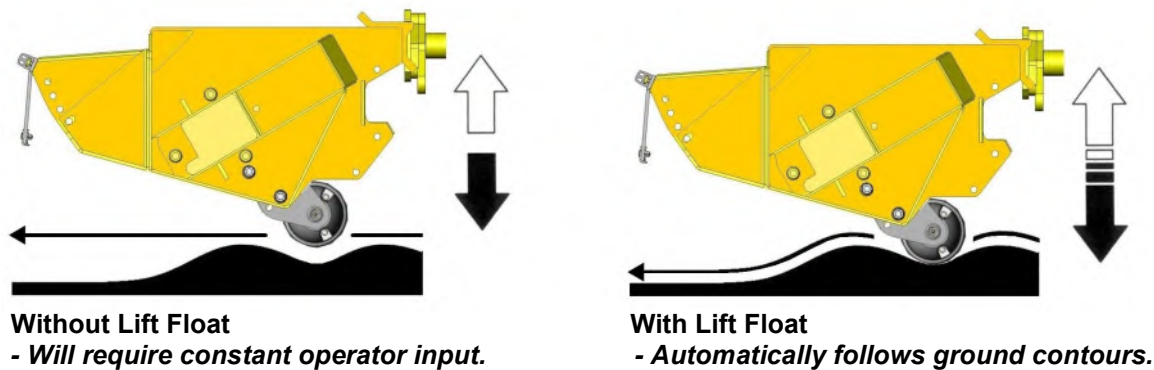

Lift float operation when supplied as a factory fitted option is controlled from the controls unit that accompanied the machine (*refer to controls section for details*), but the feature is also available for a range of models as an after market kit, in which case operation will either be via an auxiliary switch on cable controlled machines, or by utilisation of the auxiliary three-position type switch on the control unit of electric controlled machines - *this will allow for selection of 'lift float alone' or 'lift and angle float in unison' if both features are fitted.* Operation of the lift float control for these models will then be as specified in the main controls section.

Power Connection on Cable Machines

On cable controlled machines the switch supplied will need to be mounted in a convenient location in the cab. The supply cable from the poppet valve solenoid must be connected into the tractors ignition system - the brown lead is positive and the blue lead is negative.

Power Connection on Electric Machines

On electric controlled machines power to the unit is via the following connections:

Machines with 14 core looms use connection 10 and common connection 11.

Machines with 19 core looms use connection 15 and common connection 16.

Revolution Non-EDS proportional machines use connections LF and C.

Depending on the particular machine after market lift float kits will either be frame mounted or ram mounted – they should be fitted and positioned in a location where they do not foul or interfere with other components during normal movements of the machine.

ANGLE FLOAT KIT (Standard Feature)

Machines are fitted with Angle Float as standard – when activated the feature connects the base and gland circuits of the angle ram to allow free movement of oil in both directions thus allowing the head to automatically angle itself to match the contours of the ground.

Refer to specific controls section for details of operation.

NOTE: On machines with Revolution proportional controls any operation of the angle float thumbwheel will override and de-activate the automatic angle float function, on release of the thumbwheel it will revert back to automatic angle float.

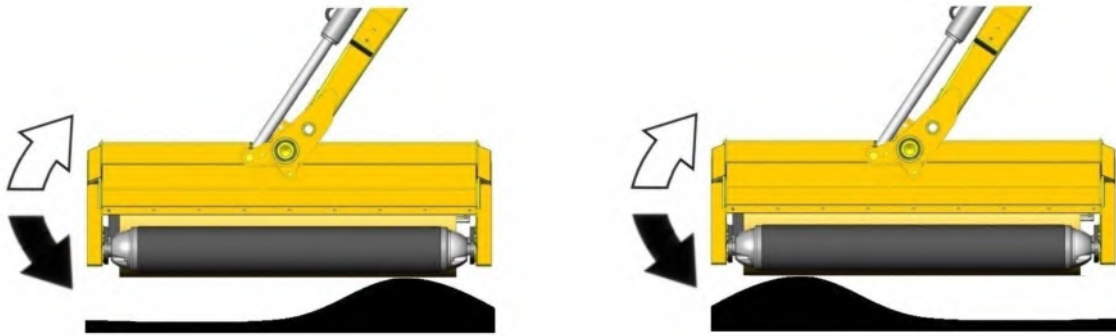

Angle Float Off – Requires operator input to adjust flail head angle.

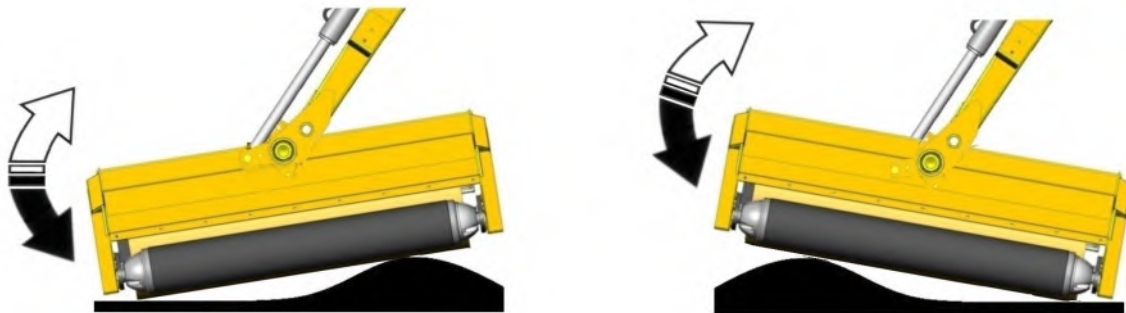

Angle Float On – Flail head automatically angles itself to match the ground contours.

GENERAL MAINTENANCE

General Lubrication

The illustration below shows the locations of the machines lubrication points - all points should be greased on a daily basis and prior storage of the machine. New machines and PTO shaft must be fully greased prior to first use.

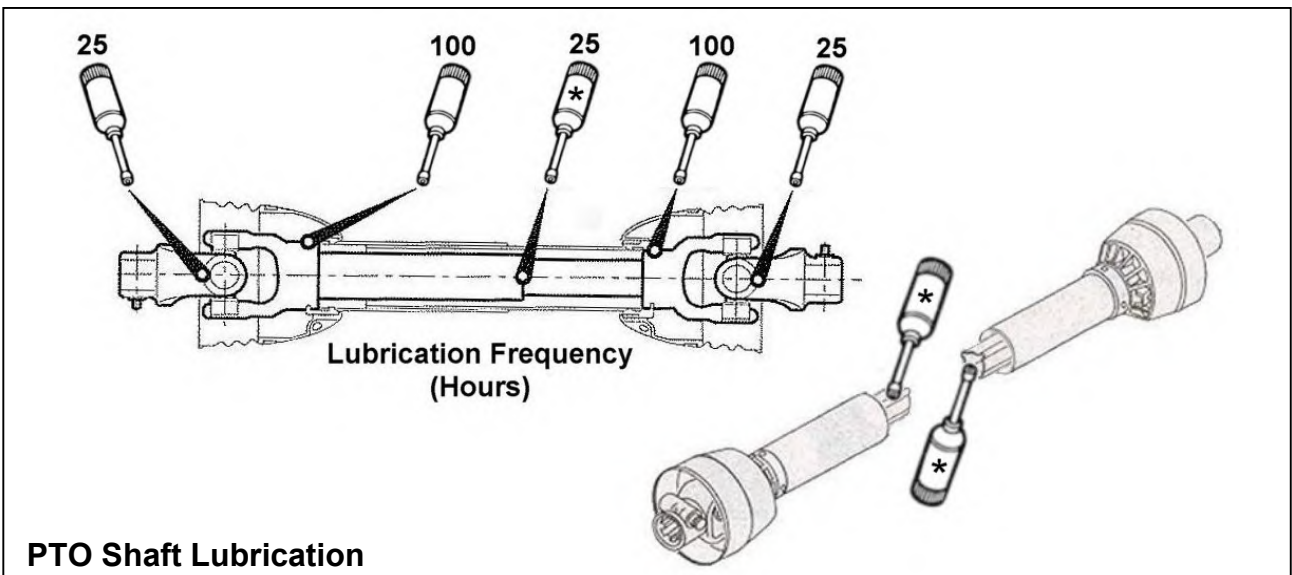
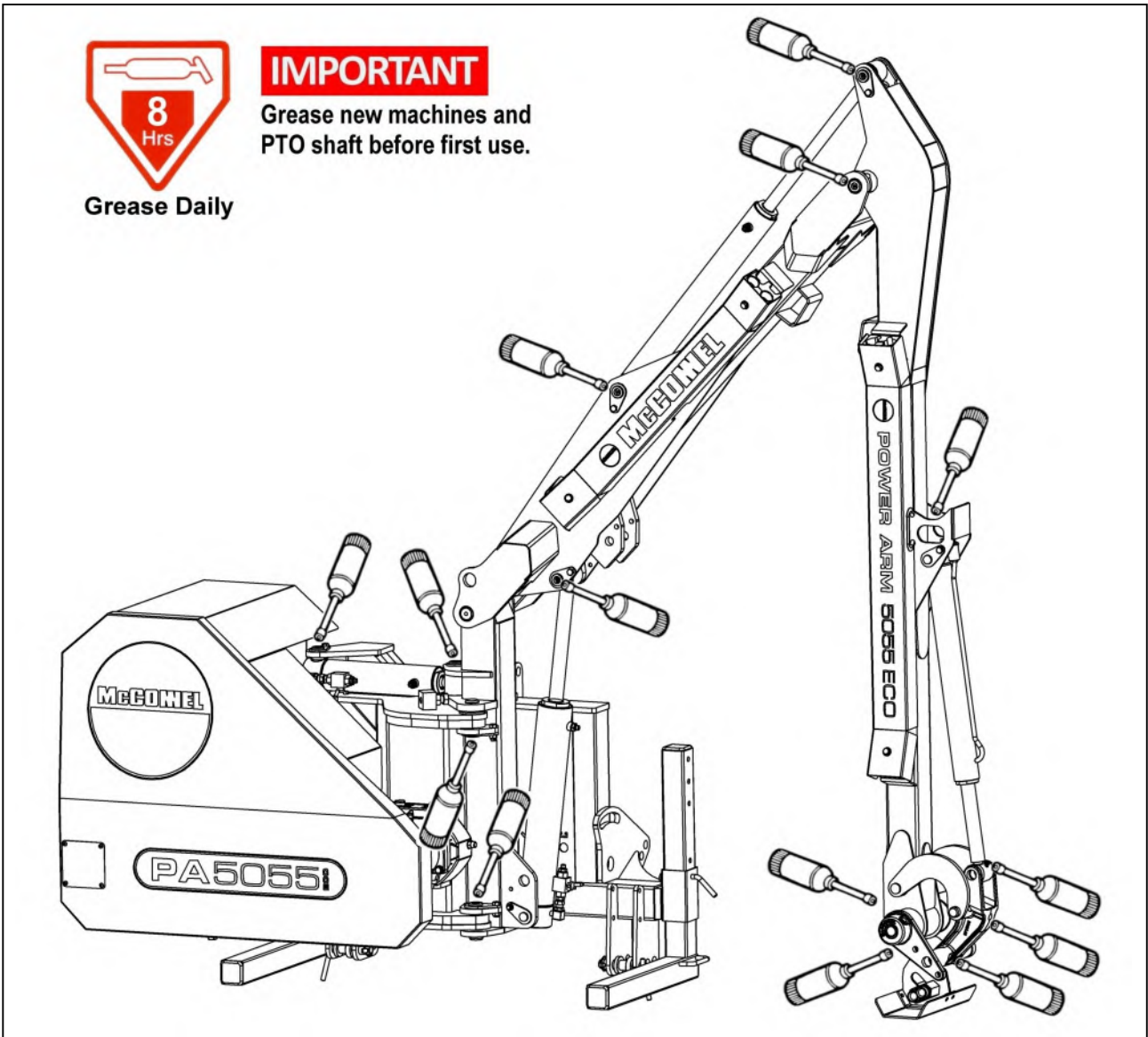

PTO Gearbox

Check gearbox oil level on new machines prior to first use, top up if required before using the machine. **Replace gearbox oil after an initial 50 hours of use** and thereafter at annual or 500 hour intervals; whichever occurs earliest.

Gearbox Capacity (Machines ► 11/13)

0.7 Litre SAE75W90 Fully Synthetic which meets the following minimum requirements;

Viscosity at 40°C, cSt, 100.0 min.

Viscosity at 100°C, cSt, 17.2 min.

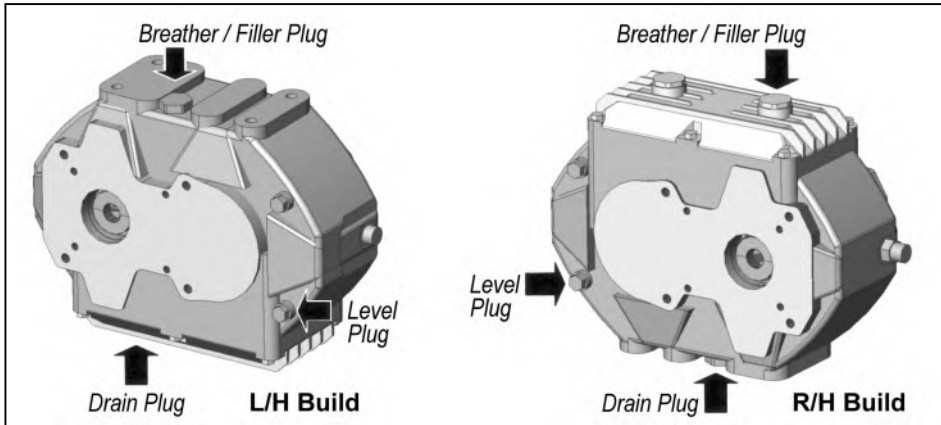

Drainage of the gearbox for an oil change is via the drain plug located on the base of the gearbox.

To refill or for 'topping up' remove filler and level plugs indicated opposite and fill gearbox via the filler plug to a point where the oil starts to run from the level plug orifice. Replace both plugs and tighten.

Gearbox Capacity (Machines 11/13 ►)

0.6 Litre SAE75W90 Fully Synthetic which meets the following minimum requirements;

Viscosity at 40°C, cSt, 100.0 min.

Viscosity at 100°C, cSt, 17.2 min.

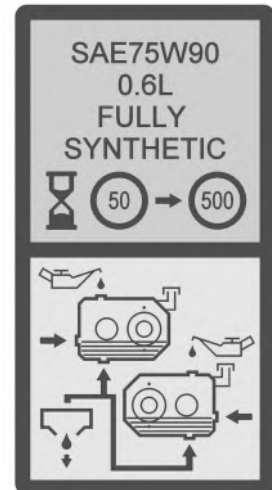
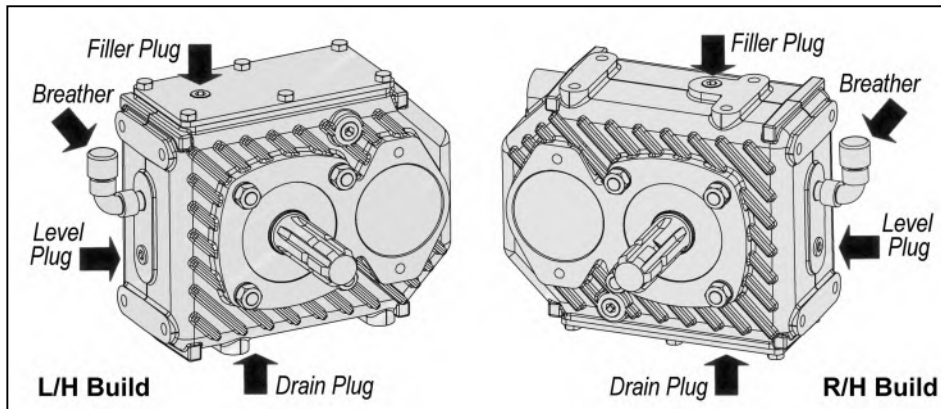

SERVICE SCHEDULE

Every Day	
<ul style="list-style-type: none">• Grease machine fully prior to work (and prior to storage). NOTE: New machines <u>must be fully greased</u> before initial use.• Check for broken or damaged flails.• Check tightness of flail nuts and bolts.• Visually check for oil leaks and damaged hoses.• Check all guards and safety shields are correctly fitted and undamaged.• Ensure all lights are working and clean.• Check oil level.• Clean cooler matrix; in dusty conditions more frequent cleaning is required.	
After initial 50-hours	
<ul style="list-style-type: none">• Change gearbox oil.	
Every 25-hours	
<ul style="list-style-type: none">• Grease PTO Shaft universal joints and tubes.	
Every Week	
<ul style="list-style-type: none">• Check tightness of all nuts and bolts.• Check gearbox oil level.• Check for wear on telescopic arm pads – <i>where applicable</i>.	
Every 100-hours	
<ul style="list-style-type: none">• Grease PTO shaft shield lubrication points.• Check bushes for wear; <i>wherever possible, remove end caps to allow inspection</i>.	
Every 500-hours	
<ul style="list-style-type: none">• Change return line filter element (<i>500-hours or annually, whichever occurs first</i>).• Change tank breather.• Change gearbox oil.• Check condition of hydraulic oil and change if required; <i>when changing the oil, new return line filter and suction strainer elements should be fitted and the return line filter changed again after 100 hours of work</i>.	
Annually	
<ul style="list-style-type: none">• Change tank breather.	

Cooler Matrix

To ensure maximum cooler efficiency, the cooler matrix must be kept as clean as possible to allow free air flow through the unit; this is especially important in dry hot arduous conditions where the matrix can rapidly become blocked by dust causing overheating. Cooler units are best cleaned using a high-pressure air line that will clear blocked areas without risking damage to the matrix.

HYDRAULIC SYSTEM

Oil Supply

Check the oil level in the reservoir daily.

Oil Condition & Replacement

No fixed time period can be quoted for oil changes as operating conditions can vary widely but a visually inspection of the oil will often indicate its current overall state. Signs of a reduction in its condition will be apparent by changes in colour and appearance when compared to new oil. Oil in poor condition can be dark, smell rancid or burnt, or in some cases be yellow, unclear or milky in appearance indicating the presence of air or emulsified water. Moisture resulting from condensation can become entrapped in the oil causing emulsification that can block the return line filter, consequentially the filter system will be by-passed and the oil and any possible contaminants present will continue to circulate without filtration risking damage to hydraulic components. All are indications or conditions that will require replacement of the oil.

Hydraulic oil is a vital component of the machine; contaminated oil is the root cause of 70% of all hydraulic system failures. Contamination can be reduced by the following:

- Cleaning around the reservoir cap before removal, and keeping the tank area clean.
- Use of clean containers when replenishing the system.
- Regular servicing of the filtration system.

Filtration System

Machines are protected by both replaceable 125 micron suction strainers and low pressure 25 micron full flow return line filters – the diagram below is a 'scaled up' view illustrating the filtering capability built into the hydraulic system of the machine:

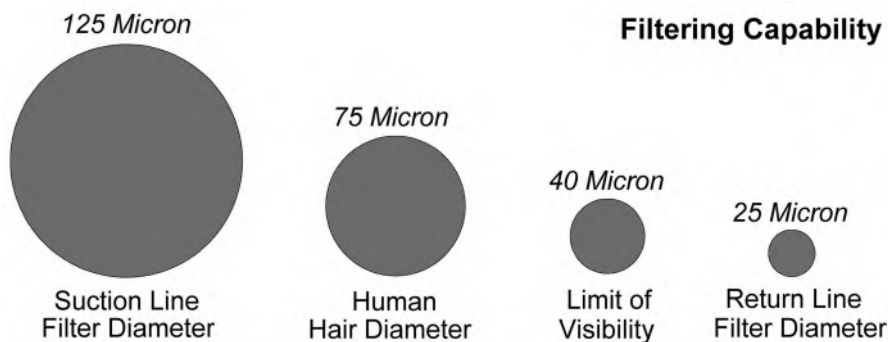

Suction strainers

The replaceable 125 micron suction strainers (*Part No. 8401097*) are fitted within the hydraulic tank and are 'screw' fitted with easy access for removal and replacement.

Return Line Filter

The 25 micron absolute filter elements (*Part No. 8401089*) should be changed after the first 100 hours or 12 months (whichever occurs first), and thereafter at 500-hour intervals. It is important to note hours worked as if the filter becomes blocked an internal by-pass within the canister will operate and no symptoms of filter malfunction will occur to jog your memory.

Tank Breather

To reduce the risk of pump cavitation it is advisable to replace the 25 micron absolute tank breather (*Part No. 8401050*) on an annual basis under normal working conditions – for machines operating in dry dusty environments it is recommended that replacement be increased to 6 monthly.

HYDRAULIC HOSES

The condition of all hoses should be carefully checked during routine service of the machine. Hoses that have been chaffed or damaged on their outer casing should be securely wrapped with waterproof adhesive tape to stop the metal braid from rusting. Hoses that have suffered damage to the metal braid should be changed at the earliest opportunity.

Hose Replacement

- Replace one hose at a time to avoid the risk of wrong connections.
- When the hose is screwed to an additional fitting or union, use a second spanner on the union to avoid breaking both seals.
- Do not use jointing compound on the threads.
- Avoid twisting the hose. Adjust the hose line to ensure freedom from rubbing or trapping before tightening hose end connections.

Before changing hoses study the installation these are carefully calculated to prevent hose damage during operation. Always replace hoses in exactly the same manner. This is especially important for the flail hoses where they must be crossed, upper to lower, at the dipper and head pivots.

All BSP Hydraulic Hoses fitted to McConnel Power Arms have 'Soft Seal' connections on the flail circuit and ram circuit.

Recommended torque settings for nut security:

	Nut Size	Nm	Ft-lbs	O-Ring
	1/4" BSP	24	18	P/No. 10.000.01
	3/8" BSP	33	24	P/No. 10.000.02
	1/2" BSP	44	35	P/No. 10.000.03
	5/8" BSP	58	43	P/No. 10.000.04
	3/4" BSP	84	62	P/No. 10.000.05
1" BSP	115	85	P/No. 10.000.06	

Recommended torque settings for BSP hose unions fitted in conjunction with bonded seals:

	Union Size	Nm	Ft-lbs	Bonded Seal
	1/4" BSP	34	25	P/No. 8650102
	3/8" BSP	75	55	P/No. 8650103
	1/2" BSP	102	75	P/No. 8650104
	5/8" BSP	122	90	P/No. 8650105
	3/4" BSP	183	135	P/No. 8650106
1" BSP	203	150	P/No. 8650108	

Safety Note

The soft seal hose connections are capable of holding pressure when the nut is only finger tight, it is therefore recommended when dismantling that the hose be manually flexed with the retaining nut slackened to relieve any residual pressure prior to complete disassembly.

CONTROL CABLES

The control cables operate on a push/pull system with the spool centring springs always returning the spool to the neutral position when the handle is released.

Care should be taken during installation and operation to ensure that the cables are not trapped or kinked. Any abrasion or damage to the outer casing should be sealed with plastic insulation tape to avoid moisture penetrating.

No routine adjustments of the cables are necessary, as they do not stretch. The threaded collar is correctly adjusted when the lever is in a vertical position in its housing allowing an equal amount of travel in either direction.

CAUTION!

On no account should any attempt be made to lubricate the cables – these are assembled with a special ‘lifelong’ lubricant during manufacture and will not require any additional lubrication.

Note: Take care to ascertain the correct cable connections on both the control unit and the valve in the event of cable replacement.

PTO SHAFT MAINTENANCE

PTO Shaft Lubrication

The PTO shaft should be lubricated on a regular basis using lithium based grease – each end of the shaft has 2 greasing points; one for lubrication of the universal joint and one for lubricating the rotating fixing ring of the shaft shield – access to the lubrication points is gained by releasing the shaft shield from its fixing ring and sliding it back along the body of the driveshaft – *the procedure and lubrication frequency is illustrated below.*



Shaft shield fixing clasps



Insert screwdrivers into the clasps



Pry clasps open to release the shield



Slide shield back to reveal universal joint

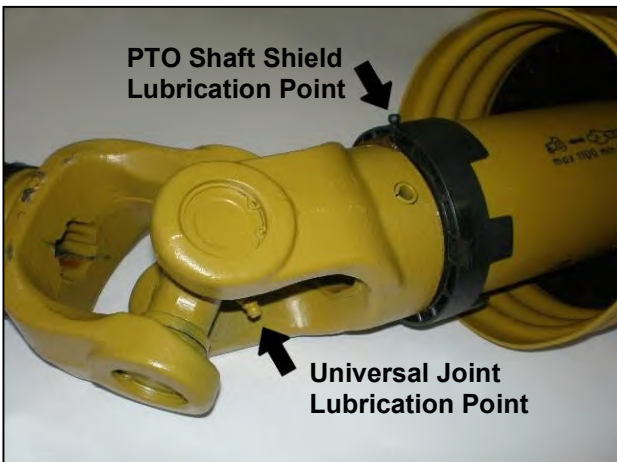

Location of lubrication points

Slide the shaft shield back into place after lubrication ensuring the clasps relocate correctly in the fixing ring – always fit torque chains to the shields to stop them from rotating with the shaft during operation.

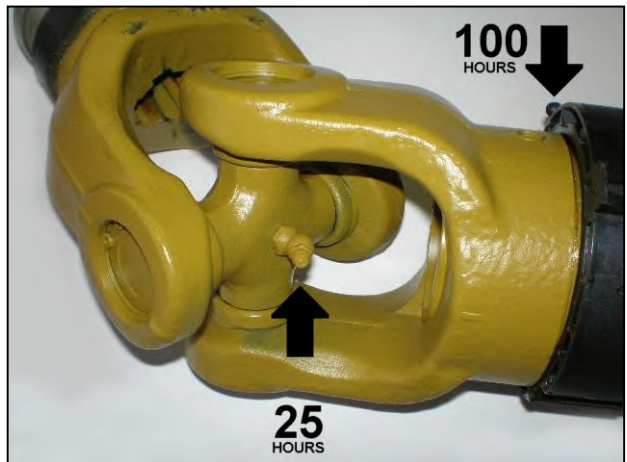

Recommended lubricating frequency

TORQUE SETTINGS FOR FASTENERS

The chart below lists the correct tightening torque for fasteners. This chart should be referred to when tightening or replacing bolts in order to determine the grade of bolt and the correct torque unless specific torque values are assigned in the text of the manual.

Recommended torque is quoted in Foot-Pounds and Newton-Metres within this manual. The equation for conversion is 1 Nm. = 0.7376 ft.lbs.

TORQUE VALUES FOR IMPERIAL BOLTS

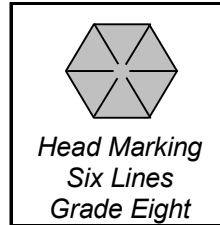
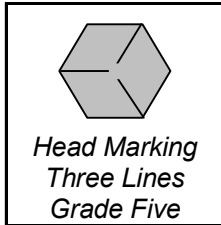
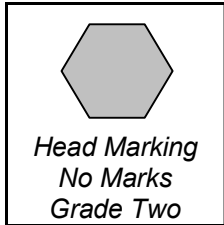

NOTE:
The values in the chart apply to fasteners as received from the supplier, dry or when lubricated with normal engine oil. They DO NOT apply if special graphited, molydisulphide greases, or other extreme pressure lubricants are used. This applies to both UNF and UNC coarse threads.

Bolt Dia.
1/4"
5/16"
3/8"
7/16"
1/2"
9/16"
5/8"
3/4"
7/8"
1"
1-1/8"
1-1/4"
1-3/8"
1-1/2"

Value (Dry)	
ft.lb.	Nm.
5.5	7.5
11	15.0
20	27.0
32	43.0
50	68.0
70	95.0
100	135.0
175	240.0
175	240.0
270	360.0
375	510.0
530	720.0
700	950.0
930	1250.0

Value (Dry)	
ft.lb.	Nm.
9	12.2
18	25.0
33	45.0
52	70.0
80	110.0
115	155.0
160	220.0
280	380.0
450	610.0
675	915.0
850	115.0
1200	1626.0
1550	2100.0
2100	2850.0

Value (Dry)	
ft.lb.	Nm.
12.5	17.0
26	35.2
46	63.0
75	100.0
115	155.0
160	220.0
225	305.0
400	540.0
650	880.0
975	1325.0
1350	1830.0
1950	2650.0
2550	3460.0
3350	4550.0

TORQUE VALUES FOR METRIC BOLTS.

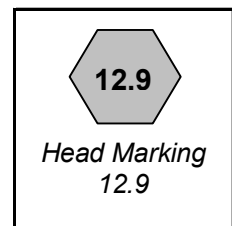
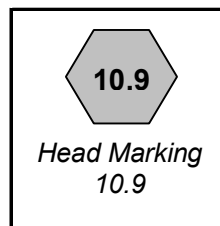
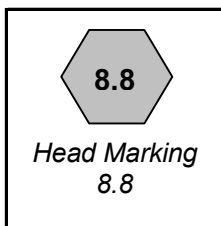
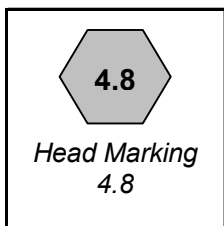

Bolt Dia.
6mm
8mm
10mm
12mm
14mm
16mm
18mm
20mm
22mm
24mm
27mm
30mm

Value (Dry)	
ft.lb.	Nm.
4.5	6.1
11	14.9
21	28.5
37	50.2
60	81.4
92	125.0
125	170.0
180	245.0
250	340.0
310	420.0
450	610.0
625	850.0

Value (Dry)	
ft.lb.	Nm.
8.5	11.5
20	27.1
40	54.2
70	95.0
110	150.0
175	240.0
250	340.0
350	475.0
475	645.0
600	810.0
875	1180.0
1200	1626.0

Value (Dry)	
ft.lb.	Nm.
12	16.3
30	40.1
60	81.4
105	140.0
165	225.0
255	350.0
350	475.0
500	675.0
675	915.0
850	1150.0
1250	1700.0
1700	2300.0

Value (Dry)	
ft.lb.	Nm.
14.5	20.0
35	47.5
70	95.0
120	160.0
190	260.0
300	400.0
410	550.0
580	790.0
800	1090.0
1000	1350.0
1500	2000.0
2000	2700.0

TROUBLESHOOTING CHART

The chart below lists possible causes and solutions to problems that may be encountered.

PROBLEM	POSSIBLE CAUSE	SOLUTION
Gearbox overheating	Oil level incorrect	Check oil level
	Oil grade incorrect	Check oil grade
	Implement overloaded	Reduce forward speed
	Wrong PTO speed	Ensure tractor PTO speed matches implement
Excessive belt wear	Belt and pulley condition	Replace if necessary
	Pulley alignment	Check alignment
	Incorrect belt tension	Tension belts to spec
	Overloading of implement	Reduce forward speed or increase cut height
PTO wear / UJ failure	Working angle too great	Reduce mis-alignment of drive stub shafts
	Shaft length incorrect; bottoming out	Resize PTO shaft as recommended
	Lack of maintenance	Grease PTO shaft as recommended
Cut Quality	Flails worn or damaged	Replace worn/damaged flails
	Rotor speed / direction	Check rotor direction/tractor PTO speed
	Cutting conditions	Work in suitable cutting conditions
Rotor bearing failure	Rotor out of balance	Refer to rotor vibration below
	Wire / string in bearing	Remove wire / string
	Lack of maintenance	Grease bearings to schedule
	Moisture in bearing(s)	Grease bearing(s) to expel moisture
Rotor vibration	Flails broken or missing	Replace flails
	Bearings worn or damaged	Replace bearings
	Rotor unbalanced / bent	Re-balance / replace rotor
	Debris build up	Remove debris
	Incorrect speed	Check rotor RPM
Oil tank overheating	Oil level incorrect	Fill tank to correct level
	Oil grade incorrect	Drain and refill tank with correct grade oil
	PTO speed too fast	Match the tractor's PTO speed to machine
	Ambient temperature too high	Reduce work rate / install oil cooler
	Machine overloaded	Reduce forward speed or increase cut height
Frequent Break-back	Machine overloaded	Reduce forward speed or increase cut height
	Working on excessive incline	Disable auto-reset
	Machine weight sat on rear roller	Raise head or operate with head float
	Machine not set vertical	Adjust top link
Hydraulics not responding	Internal valve leakage	Contact local dealer or McConnel Service
	Oil level low	Fill oil to correct level
	Oil pump suction filter blocked	Replace filter element
	Oil leak in pressure line	Check machine for hydraulic leaks
Irregular arm movement	Drive line broken	Check pump is rotating
	Spool contacting with housing	Check spool moves freely
	Broken spring in spool valve	Check spring in spool valve
Electric valve unresponsive	Ram seal failure	Replace ram seals
	Faulty wiring	Check wiring and switches
	Dirt in valve	Check for ingress of dirt
	Sticking valve	Replace the valve
Insufficient voltage	Insufficient voltage	Ensure power is sourced direct from battery



McConnel Limited, Temeside Works, Ludlow, Shropshire SY8 1JL. England.
Telephone: 01584 873131. Facsimile: 01584 876463. www.mcconnel.com