

Publication 838  
April 2016  
Part No. 23671.38



# PA8085M

## 85HP MID-MOUNT HEDGE CUTTER / MOWER

### Operator Manual

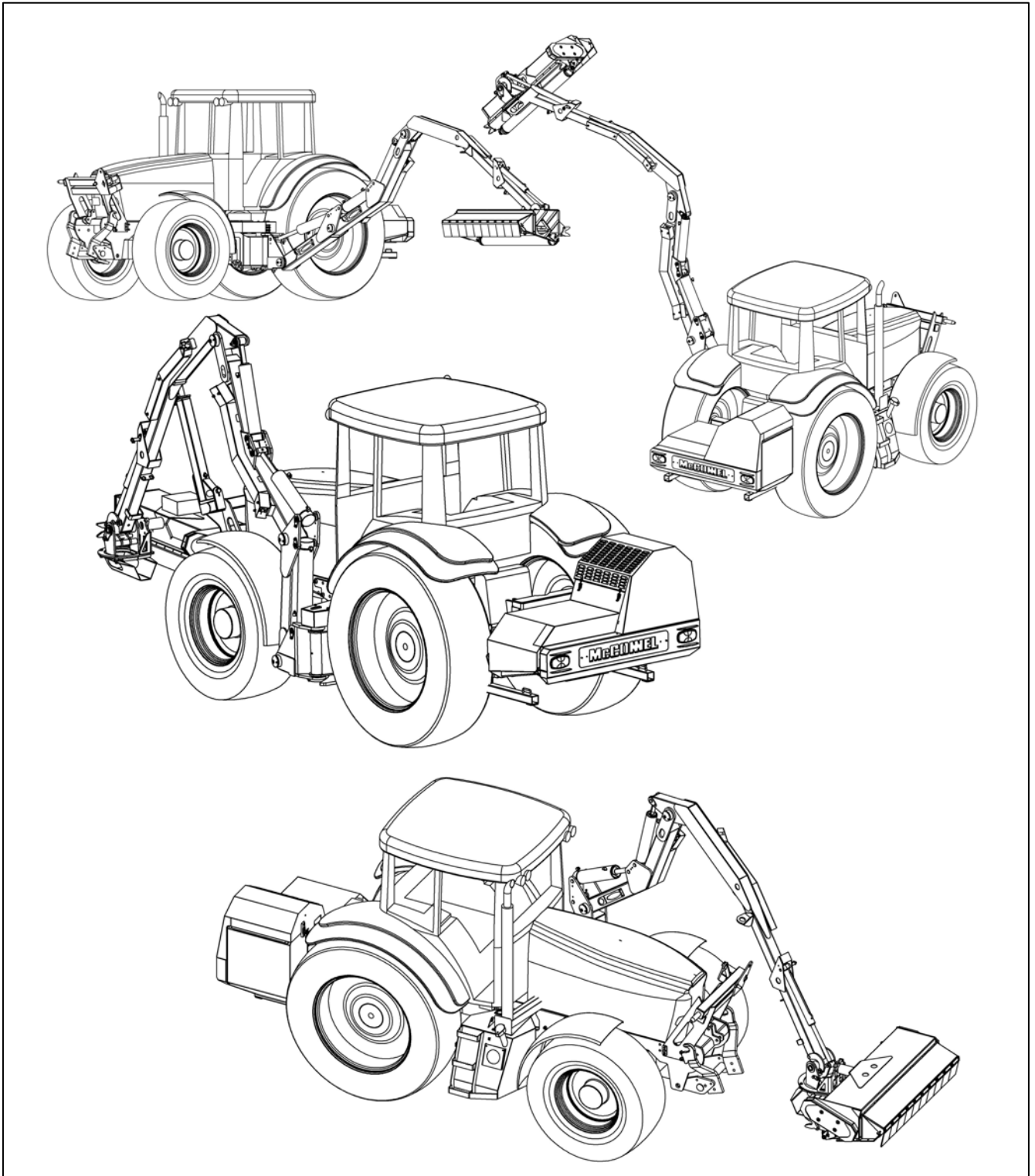

# IMPORTANT

## VERIFICATION OF WARRANTY REGISTRATION



### DEALER WARRANTY INFORMATION & REGISTRATION VERIFICATION

It is imperative that the selling dealer registers this machine with McConnel Limited before delivery to the end user – failure to do so may affect the validity of the machine warranty.

To register machines go to the McConnel Limited web site at [www.mccommel.com](http://www.mccommel.com), log onto 'Dealer Inside' and select the 'Machine Registration button' which can be found in the Service Section of the site. Confirm to the customer that the machine has been registered in the section below.

Should you experience any problems registering a machine in this manner please contact the McConnel Service Department on 01584 875848.

#### Registration Verification

Dealer Name: .....
Dealer Address: .....
Customer Name: .....
Date of Warranty Registration: ...../...../..... Dealer Signature: .....

#### NOTE TO CUSTOMER / OWNER

*Please ensure that the above section above has been completed and signed by the selling dealer to verify that your machine has been registered with McConnel Limited.*

**IMPORTANT:** During the initial 'bedding in' period of a new machine it is the customer's responsibility to regularly inspect all nuts, bolts and hose connections for tightness and re-tighten if required. New hydraulic connections occasionally weep small amounts of oil as the seals and joints settle in – where this occurs it can be cured by re-tightening the connection – *refer to torque settings chart below*. The tasks stated above should be performed on an hourly basis during the first day of work and at least daily thereafter as part of the machines general maintenance procedure.

**CAUTION: DO NOT OVER TORQUE HYDRAULIC FITTINGS AND HOSES**

#### TORQUE SETTINGS FOR HYDRAULIC FITTINGS

HYDRAULIC HOSE ENDS		
BSP	Setting	Metric
1/4"	18 Nm	19 mm
3/8"	31 Nm	22 mm
1/2"	49 Nm	27 mm
5/8"	60 Nm	30 mm
3/4"	80 Nm	32 mm
1"	125 Nm	41 mm
1.1/4"	190 Nm	50 mm
1.1/2"	250 Nm	55 mm
2"	420 Nm	70 mm

PORT ADAPTORS WITH BONDED SEALS		
BSP	Setting	Metric
1/4"	34 Nm	19 mm
3/8"	47 Nm	22 mm
1/2"	102 Nm	27 mm
5/8"	122 Nm	30 mm
3/4"	149 Nm	32 mm
1"	203 Nm	41 mm
1.1/4"	305 Nm	50 mm
1.1/2"	305 Nm	55 mm
2"	400 Nm	70 mm

# WARRANTY POLICY

## WARRANTY REGISTRATION

All machines must be registered, by the selling dealer with McConnel Ltd, before delivery to the end user. On receipt of the goods it is the buyer's responsibility to check that the Verification of Warranty Registration in the Operator's Manual has been completed by the selling dealer.

### 1. LIMITED WARRANTIES

- 1.01. *All machines supplied by McConnel Ltd are warranted to be free from defects in material and workmanship from the date of sale to the original purchaser for a period of 12 months, unless a different period is specified.*
- 1.02. *All spare parts supplied by McConnel Ltd and purchased by the end user are warranted to be free from defects in material and workmanship from the date of sale to the original purchaser for a period of 6 months. All parts warranty claims must be supported by a copy of the failed part invoice to the end user. We cannot consider claims for which sales invoices are not available.*
- 1.03. *The warranty offered by McConnel Ltd is limited to the making good by repair or replacement for the purchaser any part or parts found, upon examination at its factory, to be defective under normal use and service due to defects in material or workmanship. Returned parts must be complete and unexamined. Pack the component(s) carefully so that any transit damage is avoided. All ports on hydraulic items should be drained of oil and securely plugged to prevent seepage and foreign body ingress. Certain other components, electrical items for example, may require particular care when packing to avoid damage in transit.*
- 1.04. *This warranty does not extend to any product from which McConnel Ltd's serial number plate has been removed or altered.*
- 1.05. *This warranty does not apply to any part of the goods, which has been subjected to improper or abnormal use, negligence, alteration, modification, fitment of non-genuine parts, accident damage, or damage resulting from contact with overhead power lines, damage caused by foreign objects (e.g. stones, iron, material other than vegetation), failure due to lack of maintenance, use of incorrect oil or lubricants, contamination of the oil, or which has served its normal life. This warranty does not apply to any expendable items such as blades, belts, clutch linings, filter elements, flails, flap kits, skids, soil engaging parts, shields, guards, wear pads, pneumatic tyres or tracks.*
- 1.06. *Temporary repairs and consequential loss - i.e. oil, downtime and associated parts are specifically excluded from the warranty.*
- 1.07. *Warranty on hoses is limited to 12 months and does not include hoses which have suffered external damage. Only complete hoses may be returned under warranty, any which have been cut or repaired will be rejected.*
- 1.08. *Machines must be repaired immediately a problem arises. Continued use of the machine after a problem has occurred can result in further component failures, for which McConnel Ltd cannot be held liable, and may have safety implications.*
- 1.09. *If in exceptional circumstances a non McConnel Ltd part is used to effect a repair, warranty reimbursement will be at no more than McConnel Ltd's standard dealer cost for the genuine part.*
- 1.10. *Except as provided herein, no employee, agent, dealer or other person is authorised to give any warranties of any nature on behalf of McConnel Ltd.*
- 1.11. *For machine warranty periods in excess of 12 months the following additional exclusions shall apply:*
  - 1.11.1. *Hoses, exposed pipes and hydraulic tank breathers.*
  - 1.11.2. *Filters.*
  - 1.11.3. *Rubber mountings.*
  - 1.11.4. *External electric wiring.*
  - 1.11.5. *Bearings and seals.*

- 1.12. All service work, particularly filter changes, must be carried out in accordance with the manufacturer's service schedule. Failure to comply will invalidate the warranty. In the event of a claim, proof of the service work being carried out may be required.
- 1.13. Repeat or additional repairs resulting from incorrect diagnosis or poor quality previous repair work are excluded from warranty.

**NB Warranty cover will be invalid if any non-genuine parts have been fitted or used. Use of non-genuine parts may seriously affect the machine's performance and safety. McConnel Ltd cannot be held responsible for any failures or safety implications that arise due to the use of non-genuine parts.**

## **2. REMEDIES AND PROCEDURES**

- 2.01. The warranty is not effective unless the Selling Dealer registers the machine, via the McConnel Ltd web site and confirms the registration to the purchaser by completing the confirmation form in the operator's manual.
- 2.02. Any fault must be reported to an authorised McConnel Ltd dealer as soon as it occurs. Continued use of a machine, after a fault has occurred, can result in further component failure for which McConnel Ltd cannot be held liable.
- 2.03. Repairs should be undertaken within two days of the failure. Claims submitted for repairs undertaken more than 2 weeks after a failure has occurred, or 2 days after the parts were supplied will be rejected, unless the delay has been authorised by McConnel Ltd. Please note that failure by the customer to release the machine for repair will not be accepted as a reason for delay in repair or submitting warranty claims.
- 2.04. All claims must be submitted, by an authorised McConnel Ltd Service Dealer, within 30 days of the date of repair.
- 2.05. Following examination of the claim and parts, McConnel Ltd will pay, at their discretion, for any valid claim the invoiced cost of any parts supplied by McConnel Ltd and appropriate labour and mileage allowances if applicable.
- 2.06. The submission of a claim is not a guarantee of payment.
- 2.07. Any decision reached by McConnel Ltd is final.

## **3. LIMITATION OF LIABILITY**

- 3.01. McConnel Ltd disclaims any express (except as set forth herein) and implied warranties with respect to the goods including, but not limited to, merchantability and fitness for a particular purpose.
- 3.02. McConnel Ltd makes no warranty as to the design, capability, capacity or suitability for use of the goods.
- 3.03. Except as provided herein, McConnel Ltd shall have no liability or responsibility to the purchaser or any other person or entity with respect to any liability, loss, or damage caused or alleged to be caused directly or indirectly by the goods including, but not limited to, any indirect, special, consequential, or incidental damages resulting from the use or operation of the goods or any breach of this warranty. Notwithstanding the above limitations and warranties, the manufacturer's liability hereunder for damages incurred by the purchaser or others shall not exceed the price of the goods.
- 3.04. No action arising out of any claimed breach of this warranty or transactions under this warranty may be brought more than one (1) year after the cause of the action has occurred.

## **4. MISCELLANEOUS**

- 4.01. McConnel Ltd may waive compliance with any of the terms of this limited warranty, but no waiver of any terms shall be deemed to be a waiver of any other term.
- 4.02. If any provision of this limited warranty shall violate any applicable law and is held to be unenforceable, then the invalidity of such provision shall not invalidate any other provisions herein.
- 4.03. Applicable law may provide rights and benefits to the purchaser in addition to those provided herein.



# DECLARATION OF CONFORMITY

*Conforming to EU Machinery Directive 2006/42/EC*

We,

**McCONNEL LIMITED**, Temeside Works, Ludlow, Shropshire SY8 1JL, UK

*Hereby declare that:*

The Product; *Tractor Mid-Mounted Hedgecutter / Grass Mower*

Product Code; *P800*

Serial No. & Date ..... Type .....

Manufactured in; *United Kingdom*

Complies with the required provisions of the Machinery Directive 2006/42/EC  
The machinery directive is supported by the following harmonized standards;

- BS EN ISO 12100 (2010) Safety of machinery – General principles for design – Risk assessment and risk reduction.
- BS EN 349 (1993) + A1 (2008) Safety of machinery - Minimum distances to avoid the entrapment with human body parts.
- BS EN 953 (1997) + A1 (2009) Safety of machinery - Guards general requirements for the design and construction of fixed and movable guards.
- BS EN 4413 (2010) Hydraulic fluid power. Safety requirements for systems and their components.

McCONNEL LIMITED operates an ISO 9001:2008 quality management system, certificate number: FM25970.

This system is continually assessed by the;

British Standards Institution (BSI), Beech House, Milton Keynes, MK14 6ES, UK  
BSI is accredited by UK Accreditation Service, accreditation number: UKAS 003.  
The EC declaration only applies if the machine stated above is used in accordance with the operating instructions.

Signed  ..... *Responsible Person*  
*CHRISTIAN DAVIES on behalf of McCONNEL LIMITED*

Status: *General Manager*

Date: *September 2015*

## **POWER ARM INSPECTION AND MAINTENANCE**

---

A daily equipment inspection of the tractor and mower should be conducted before the equipment is used. You may use the inspection sheets to assist with these daily inspections. Any damaged or missing guards should be repaired or replaced before operating the mower. Failure to repair the damaged shield can result in objects being thrown from the mower and possibly hitting the operator or bystander.

### **Inspect the Mower for Safe Operating Condition**

- Make sure the driveline guards and shielding are in place and in good repair.
- Inspect the flexible thrown object shielding to assure that they are in place on the front and rear of the mower head and in good repair. Repair or replace any damaged or missing thrown object shields.
- Ensure the mower cutting height is set high enough to reduce the possibility of the mower blades contacting the ground. Actual height will be dependent on the ground conditions. Increase the height when working in rough or undulating conditions.
- Inspect for broken, chipped, bent, missing, or severely worn blades. Replace damaged blades before operating the mower. Ensure the blade retaining bolts and fasteners are secure and tight.
- Ensure all head bolts and nuts are tight.
- Lubricate the driveline universal joints and telescoping members daily.
- Grease the rotor and roller bearings and inspect their condition.
- Inspect for any oil leaks or damaged hoses
- Inspect for worn or damaged decals and safety instructions. Replace unreadable, damaged or missing safety decals.
- Follow the operator's manual(s) inspection and maintenance instructions for lubricating parts, and keeping thrown object shielding, driveline guards, rotating parts shields, mower blades and decals in good repair.

### **Inspect the Tractor for Safe Operating Condition:**

- Inspect the controls, lights, SMVs (Slow Moving Vehicle sign), seat belts, and ROPS to assure that they are in place and in good working order.
- Be sure the tires, wheels, lug bolts/nuts are in good condition.
- Make sure the tractor brakes and steering are in proper operating condition.
- Follow the operator's manual(s) inspection and maintenance procedures for keeping the tractor in good and safe condition before operating.

The inspection sheet on the following page should be kept in this book as a record. A second sheet is included for you to cut out and photocopy or the inspection sheets can be downloaded from our website at;

<http://www.mcconnel.com/support/aftersales/default.aspx?nav=After Sales>





# POWER ARM PRE-OPERATION Inspection

Power Arm ID \_\_\_\_\_ Date: \_\_\_\_\_ Shift: \_\_\_\_\_

## WARNING



Before conducting the inspection, make sure the tractor engine is off, the key removed, all rotation has stopped and the tractor is in park with the parking brake engaged. Make sure the mower head is resting on the ground or is securely blocked up and supported and all hydraulic pressure has been relieved.

Item	Condition at start of shift	Specific Comments if not O.K.
The Operator's Manual is in the Canister on the mower		
All Warning Decals are in place, clean and legible		
All Lights are clean and working		
The Mounting frame bolts are in place and tight		
The Arm pivot pins are tight and correctly secured		
There are no cracks in the arms		
The Hyd. Cylinder pins are tight and correctly secured		
The Hyd Cylinder hose connections are tight		
The Hyd. Pump hose connections are tight		
The Hyd. Valve hose connections are tight		
The Hyd. Valve controls function properly		
There are no damaged hoses		
The Oil level is to the green mark on the tank sight glass		
There is no evidence of Hydraulic oil leaks		
Flails are not missing, chipped, broken or excessively worn		
The Flail bolts are tight		
The Front & Rear Flaps are fitted and in good condition		
The Front hood is in place and in good condition		
The Wire Trap is in good condition		
The Skid shoes are in good condition & tight		
There are no cracks or holes in flail casing		
The Hyd. motor mounting bolts are tight		
All Flail Head Nuts and Bolts are tight		
The Rotor Bearings are in good condition and greased		
The Roller bearings are in good condition and greased		
The drive line Shaft guard is in good condition		
The drive line shaft guard is correctly secured		
Controls are securely mounted in the cab		
With engine running check arm operation		
Have a spare pack of flails, bushes, bolts and nuts		

Operators Signature: \_\_\_\_\_

**DO NOT OPERATE an UNSAFE TRACTOR or MOWER**





# TRACTOR PRE-OPERATION Inspection

Power Arm ID \_\_\_\_\_ Date: \_\_\_\_\_ Shift: \_\_\_\_\_

## WARNING



Before conducting the inspection, make sure the tractor engine is off, the key is removed all rotation has stopped and the tractor is in park with the parking brake engaged. Any implement attached to the tractor is firmly on the ground.

Item	Condition at start of shift	Specific Comments if not O.K.
The flashing lights function properly.		
All lights are clean and working correctly		
All cab windows are clean and wipers working correctly		
The SMV sign, where required, is clean and visible.		
The tyres are in good condition with correct pressure.		
The wheel nuts are tight.		
The tractor brakes are in good condition.		
The steering linkage is in good condition.		
There are no visible oil leaks.		
The hydraulic controls function properly.		
The ROPS or ROPS cab is in good condition.		
The seatbelt is in place and in good condition.		
The 3-point hitch is in good condition.		
The drawbar/pick up hook is secure & in good condition		
The PTO master shield is in place.		
The engine oil level is full.		
The brake fluid level is full.		
The power steering fluid level is full.		
The fuel level is adequate.		
The engine coolant fluid level is full.		
The radiator & oil cooler are free of debris.		
The air filter is in good condition		

Operators Signature: \_\_\_\_\_

**DO NOT OPERATE an UNSAFE TRACTOR or MOWER**



# POWER ARM PRE-OPERATION Inspection

Power Arm ID \_\_\_\_\_ Date: \_\_\_\_\_ Shift: \_\_\_\_\_

## WARNING



Before conducting the inspection, make sure the tractor engine is off, the key removed, all rotation has stopped and the tractor is in park with the parking brake engaged. Make sure the mower head is resting on the ground or is securely blocked up and supported and all hydraulic pressure has been relieved.

Item	Condition at start of shift	Specific Comments if not O.K.
The Operator's Manual is in the Canister on the mower		
All Warning Decals are in place, clean and legible		
All Lights are clean and working		
The Mounting frame bolts are in place and tight		
The Arm pivot pins are tight and correctly secured		
There are no cracks in the arms		
The Hyd. Cylinder pins are tight and correctly secured		
The Hyd Cylinder hose connections are tight		
The Hyd. Pump hose connections are tight		
The Hyd. Valve hose connections are tight		
The Hyd. Valve controls function properly		
There are no damaged hoses		
The Oil level is to the green mark on the tank sight glass		
There is no evidence of Hydraulic oil leaks		
Flails are not missing, chipped, broken or excessively worn		
The Flail bolts are tight		
The Front & Rear Flaps are fitted and in good condition		
The Front hood is in place and in good condition		
The Wire Trap is in good condition		
The Skid shoes are in good condition & tight		
There are no cracks or holes in flail casing		
The Hyd. motor mounting bolts are tight		
All Flail Head Nuts and Bolts are tight		
The Rotor Bearings are in good condition and greased		
The Roller bearings are in good condition and greased		
The drive line Shaft guard is in good condition		
The drive line shaft guard is correctly secured		
Controls are securely mounted in the cab		
With engine running check arm operation		
Have a spare pack of flails, bushes, bolts and nuts		

Operators Signature: \_\_\_\_\_

**DO NOT OPERATE an UNSAFE TRACTOR or MOWER**



# TRACTOR PRE-OPERATION Inspection

Power Arm ID \_\_\_\_\_ Date: \_\_\_\_\_ Shift: \_\_\_\_\_

## WARNING



Before conducting the inspection, make sure the tractor engine is off, the key is removed all rotation has stopped and the tractor is in park with the parking brake engaged. Any implement attached to the tractor is firmly on the ground.

Item	Condition at start of shift	Specific Comments if not O.K.
The flashing lights function properly.		
All lights are clean and working correctly		
All cab windows are clean and wipers working correctly		
The SMV sign, where required, is clean and visible.		
The tyres are in good condition with correct pressure.		
The wheel nuts are tight.		
The tractor brakes are in good condition.		
The steering linkage is in good condition.		
There are no visible oil leaks.		
The hydraulic controls function properly.		
The ROPS or ROPS cab is in good condition.		
The seatbelt is in place and in good condition.		
The 3-point hitch is in good condition.		
The drawbar/pick up hook is secure & in good condition		
The PTO master shield is in place.		
The engine oil level is full.		
The brake fluid level is full.		
The power steering fluid level is full.		
The fuel level is adequate.		
The engine coolant fluid level is full.		
The radiator & oil cooler are free of debris.		
The air filter is in good condition		

Operators Signature: \_\_\_\_\_

**DO NOT OPERATE an UNSAFE TRACTOR or MOWER**



## READ THE BOOK FIRST

*It might save hours and pounds later!*

*When ordering spare parts always quote*

- ***The Machine Type***
- ***The Machine Serial Number***
- ***The Part Number***

*Factory re-built service exchange units of the major hydraulic components are available from your Dealer*

---

### **NOISE**

*The equivalent daily personal noise exposure from this machine, measured at the operators' ear, is within the range 78 – 85 dB.*

*These figures apply to a normal distribution of use where the noise fluctuates between zero and maximum. The figures assume that the machine is fitted to a tractor with a quiet cab with the windows closed in a generally open environment. We recommend that the windows are kept closed.*

*With the cab rear window open, the equivalent daily personal noise exposure will increase to a figure within the range 82 – 88 dB.*

*At equivalent daily noise exposure levels of between 85 and 90 dB, ear protection is recommended, it should be used if any window is left open.*

---



# LIST OF CONTENTS

---

	<i>Page No.</i>
General Information	1
Features	2
Safety Information	3
Fitting Requirements – <i>Tractor Specification &amp; Axle Locking System</i>	8
Vehicle/Tractor Preparation	9
Rear Tank Frame Attachment & Removal	10
PTO Shaft Installation	12
Flailhead Attachment	13
Detaching the Arm Unit – <i>Support &amp; Storage Frame</i>	14
Hydraulic Oil Requirements	18
Control Unit Fitting	19
Pre-Operational Checks	19
Running Up Procedure	20
Emergency Stopping	20
Operation	21
Preparation	23
Operating Speeds	24
Head Angle Float	25
Powered Slew	26
Powered Head Rotation	26
Flailhead	27
Hedge Cutting Procedure	28
Flail Types/Identification	29
Transportation Cradle	31
Transporting the Machine	32
Overhead Power Lines	33
Maintenance	35



## GENERAL INFORMATION

---

Read this manual before fitting or operating the machine or accessory. Whenever any doubt exists contact your local dealer or the McConnell Service Department for assistance.

**Only use 'Genuine McConnell Parts' on McConnell machinery and equipment.**

DEFINITIONS: *The following definitions apply throughout this manual;*

### **⚠ DANGER**

**DANGER:** Alerts to a hazardous situation which will result in death or serious injury if not observed carefully.

### **⚠ WARNING**

**WARNING:** Alerts to a hazardous situation which could result in death or serious injury if not observed carefully.

### **⚠ CAUTION**

**CAUTION:** Alerts to a hazardous situation which could result in damage to the machine and/or equipment if not observed carefully.

### **NOTICE**

**NOTICE:** Specific or general information considered important or useful to emphasise.

**LEFT HAND (LH) & RIGHT HAND (RH):** *These terms are applicable to the machine when fitted to the tractor and viewed from the rear; these terms also apply to tractor references.*

### **SERIAL PLATE**

*All machines are equipped with a serial number plate containing important information relating to the machine including a unique serial number used for identification purposes.*

*Note: Images in this manual are provided for instruction and informational purposes only and may not show components in their entirety. In certain instances images may appear different to the actual machine; where this occurs the general procedure will be basically the same. E&OE.*

## **MACHINE & DEALER INFORMATION**

Record the serial number of your machine on this page and always quote it when ordering parts. Whenever information concerning the machine is requested remember to also state the make and model of tractor to which the machine is fitted.	
Machine Serial Number:	Installation Date:
Machine Model Details:	
Dealer Name & Branch:	
Dealer Address:	
Dealer Telephone No:	
Dealer Email Address:	



## FEATURES

---

### **PA8085 Mid-Mount**

- Full chassis under frame for rigid attachment, tractor specific.
- Quick attach arm set.
- Quick release connections from arm set to rear power pack.
- 3-point linkage mounted rear frame power pack with enclosed hydraulics.
- Right or Left hand cutting.
- 85HP cast iron pump flail drive
- Independent reversible, on/off rotor operation.
- Pressure compensated piston pump powering arm movements.
- Proportional solenoid valves on main services all with manual override.
- Pilot operated check valves on all services to remove ram droop.
- Head angle float.
- High capacity oil cooler c/w removable easy access easy clean dust guard.
- Proportional controls with LED display.
- Ergonomic joystick allows up to four services to be operated simultaneously.
- Power monitor with readout on display.
- PTO speed sensor with readout on display.
- 30° of Hydraulic Breakaway
- 138° powered slew.
- 240 Litre hydraulic reservoir.
- 125micron abs Suction, 10micron abs medium pressure and 10micron abs return line filters fitted.
- Rear Lighting.
- Front frame fitting kit for stowage of Arm/head during transport
- Choice of flailhead and sawhead attachments.



## **SAFETY INFORMATION**

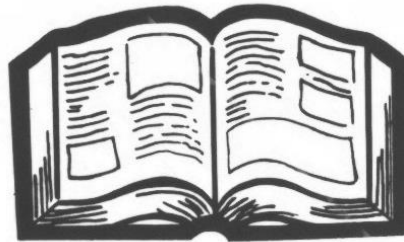

This machine has the potential to be extremely dangerous, in the wrong hands it can kill or maim. It is therefore imperative that both owner, and operator of this machine, read and understand the following section to ensure that they are fully aware of the dangers that do, or may exist, and their responsibilities surrounding the use and operation of the machine. The operator of this machine is responsible not only for their own safety but equally for the safety of others who may come into the close proximity of the machine, as the owner you are responsible for both.

When the machine is not in use the cutting head should be lowered to rest on the ground. In the event of a fault being detected with the machine's operation it should be stopped immediately and not used again until the fault has been corrected by a qualified technician.

### **POTENTIAL SIGNIFICANT DANGERS ASSOCIATED WITH THE USE OF THIS MACHINE:**

- ▲ *Being hit by debris thrown by rotating components.*
- ▲ *Being hit by machine parts ejected through damage during use.*
- ▲ *Being caught on a rotating power take-off (PTO) shaft.*
- ▲ *Being caught in other moving parts i.e.: belts, pulleys and cutting heads.*
- ▲ *Electrocution from Overhead Power Lines (by contact with or 'flashover' from).*
- ▲ *Being hit by cutting heads or machine arms as they move.*
- ▲ *Becoming trapped between tractor and machine when hitching or unhitching.*
- ▲ *Tractor overbalancing when machine arm is extended.*
- ▲ *Injection of high-pressure oil from hydraulic hoses or couplings.*
- ▲ *Machine overbalancing when freestanding (out of use).*
- ▲ *Road traffic accidents due to collision or debris on the road.*

## **BEFORE USING THIS MACHINE YOU MUST:**

- ▲ *Ensure you read all sections of the operator handbook.*
- ▲ *Ensure the operator is, or has been, properly trained to use the machine.*
- ▲ *Ensure the operator has been issued with and reads the operator handbook.*
- ▲ *Ensure the operator understands and follows the instructions in operator handbook.*
- ▲ *Ensure the tractor front, rear and side(s) are fitted with metal mesh or polycarbonate guards of suitable size and strength to protect the operator against thrown debris or parts.*
- ▲ *Ensure tractor guards are correctly fitted, undamaged and kept properly maintained.*
- ▲ *Ensure that all machine guards are in position, are undamaged, and are kept maintained in accordance with the manufacturer's recommendations.*
- ▲ *Ensure flails and their fixings are of a type recommended by the manufacturer, are securely attached and that none are missing or damaged.*
- ▲ *Ensure hydraulic pipes are carefully and correctly routed to avoid damage by chaffing, stretching or pinching and that they are held in place with the correct fittings.*
- ▲ *Always follow the manufacturer's instructions for attachment and removal of the machine from the tractor.*
- ▲ *Check that the machine fittings and couplings are in good condition.*
- ▲ *Ensure the tractor meets the minimum weight recommendations of the machine manufacturer and that ballast is used as necessary.*
- ▲ *Always inspect the work area thoroughly before starting to note obstacles and remove wire, bottles, cans and other debris.*
- ▲ *Use clear suitably sized warning signs to alert others to the nature of the machine working within that area. Signs should be placed at both ends of the work site. (It is recommended that signs used are of a size and type specified by the Department of Transport and positioned in accordance with their and the Local Highways Authority guidelines).*
- ▲ *Ensure the operator is protected from noise. Ear defenders should be worn and tractor cab doors and windows must be kept closed. Machine controls should be routed through proprietary openings in the cab to enable all windows to be shut fully.*
- ▲ *Always work at a safe speed taking account of the conditions i.e.: terrain, highway proximity and obstacles around and above the machine.*
- ▲ *Extra special attention should be applied to Overhead Power Lines. Some of our machines are capable of reach in excess of 8 metres (26 feet) this means they have the potential to well exceed, by possibly 3 metres (9' 9"), the lowest legal minimum height of 5.2 metres from the ground for 11,000 and 33,000 volt power lines. It cannot be stressed enough the dangers that surround this capability, it is therefore vital that the operator is fully aware of the maximum height and reach of the machine, and that they are fully conversant with all aspects regarding the safe minimum distances that apply when working with machines in close proximity to Power Lines. (Further information on this subject can be obtained from the Health & Safety Executive or your Local Power Company).*

- ▲ *Always disengage the machine, kill the tractor engine, remove and pocket the key before dismounting for any reason.*
- ▲ *Always clear up all debris left at the work area, it may cause hazard to others.*
- ▲ *Always ensure when you remove your machine from the tractor that it is left in a safe and stable position using the stands and props provided and secured if necessary.*

## **WHEN NOT TO USE THIS MACHINE:**

- ▲ *Never attempt to use this machine if you have not been trained to do so.*
- ▲ *Never uses a machine until you have read and understood the operator handbook, are familiar with, and practiced the controls.*
- ▲ *Never use a machine that is poorly maintained.*
- ▲ *Never use a machine if guards are missing or damaged.*
- ▲ *Never use a machine on which the hydraulic system shows signs of wear or damage.*
- ▲ *Never fit, or use, a machine on a tractor that does not meet the manufacturer's minimum specification level.*
- ▲ *Never use a machine fitted to a tractor that does not have suitable front, rear and side(s) cab guarding made of metal mesh or polycarbonate.*
- ▲ *Never use the machine if the tractor cab guarding is damaged, deteriorating or badly fitted.*
- ▲ *Never turn a machine cutting head to an angle that causes debris to be ejected towards the cab.*
- ▲ *Never start or continue to work a machine if people are nearby or approaching - Stop and wait until they are at a safe distance before continuing. WARNING: Some Cutting Heads may continue to 'freewheel' for up to 40 seconds after being stopped.*
- ▲ *Never attempt to use a machine on materials in excess of its capability.*
- ▲ *Never use a machine to perform a task it has not been designed to do.*
- ▲ *Never operate the tractor or machine controls from any position other than from the driving seat, especially whilst hitching or unhitching the machine.*
- ▲ *Never carry out maintenance of a machine or a tractor whilst the engine is running – the engine should be switched off, the key removed and pocketed.*
- ▲ *Never leave a machine unattended in a raised position – it should be lowered to the ground in a safe position on a level firm site.*
- ▲ *Never leave a tractor with the key in or the engine running.*
- ▲ *Never carry out maintenance on any part or component of a machine that is raised unless that part or component has been properly substantially braced or supported.*
- ▲ *Never attempt to detect a hydraulic leak with your hand – use a piece of cardboard.*
- ▲ *Never allow children near to, or play on, a tractor or machine under any circumstances.*

## **FRONT MOUNTED MACHINES – Additional Safety Advice**

During transportation and operation of 'Front-Mounted Machinery', the operator should be reminded that the machine is located further away from his point of vision than a rear mounted machine, and in many cases the immediate work area is out of view. Additional care should therefore be applied whilst working with machinery of this nature. The intended work area should be thoroughly scrutinised immediately prior to work to check for potential hidden hazards and dangers, bearing in mind that these may not be identifiable from the operating position on the tractor. Removable objects that may cause a hazard should be removed from the work area and any fixed hazards should be clearly indicated with a visible marker that can easily be seen from the operating position.

The operator should also be reminded that rotating cutting heads will throw debris either forwards or rearwards - dependent upon the nature of the job - it is therefore vital that suitable safety guarding is fitted where danger to either the operator, bystanders or property exists. Tractor windows should be protected with suitable materials of the correct specification to ensure the safety of the operator whilst allowing good all round visibility without impairing the functions of the tractor. Any side guarding fitted to the tractor to protect it from thrown debris should be fitted in such a way that it does not further obscure the operators vision of the machine or the working area. – *Contact your tractor manufacturer or local dealer for advice on this subject.*

## **ADDITIONAL SAFETY ADVICE**

### **Training**

Operators need to be competent and fully capable of operating this machine in a safe and efficient way prior to attempting to use it in any public place. We advise therefore that the prospective operator make use of relevant training courses available such as those run by the Agricultural Training Board, Agricultural Colleges, Dealers and McConnel.

### **Working in Public Places**

When working in public places such as roadsides, consideration should be paid to others in the vicinity. Stop the machine immediately when pedestrians, cyclists and horse riders etc. pass. Restart only when they are at a distance that causes no risk to their safety.

### **Warning Signs**

It is advisable that any working area be covered by suitable warning signs and statutory in public places. Signs should be highly visible and well placed in order to give clear advanced warning of the hazard. Contact the Department of Transport or your Local Highways Authority to obtain detailed information on this subject. The latter should be contacted prior to working on the public highway advising them of the time and location of the intended work asking what is required by way of signs and procedure. – *'Non-authorized placement of road signs may create offences under the Highways Act'*.

## **SUGGESTED WARNING SIGNS REQUIRED**

*“Road works ahead” warning sign with a supplementary “Hedge cutting” plate. “For 1 mile” or appropriate shorter distance may be added to the plate.*

*“Road narrows” warning sign with supplementary “Single file traffic” plate.*

*White on blue “Keep right” arrow sign on rear of machine.*

### **USE OF WARNING SIGNS**

- *On two way roads one set of signs is needed facing traffic in each direction.*
- *Work should be within 1 mile of the signs.*
- *Work only when visibility is good and at times of low risk e.g.: NOT during ‘rush-hour’.*
- *Vehicles should have an amber flashing beacon.*
- *Ideally, vehicles should be conspicuously coloured.*
- *Debris should be removed from the road and path as soon as practicable, and at regular intervals, wearing high visibility clothing and before removing the hazard warning signs.*
- *Collect all road signs promptly when the job is completed.*

---

*Although the information given here covers a wide range of safety subjects it is impossible to predict every eventuality that can occur under differing circumstances whilst operating this machine. No advice given here can replace ‘good common sense’ and ‘total awareness’ at all times but it will go a long way towards the safe use of your McConnel machine.*

---

## FITTING - Tractor requirements

---

**Minimum Tractor Weights** - including ballast weight if necessary:  
7800 kg.

**Minimum HP requirements:**  
120 HP

**Linkage:**  
Category 2 Rear Linkage

**PTO shaft:**  
800 RPM with a 6-spline output required.

## AXLE LOCKING BRACKETS

---

For additional stability of the unit during work an 'Axle Locking System' may be fitted to the tractor. The axle locking system comprises of 2 pairs of brackets attached to the front axle and chassis on each side of the tractor - the axle and chassis brackets are each connected by a hydraulic ram which, when activated via the tractors external service, will lock the axle rigidly to the tractor chassis.

For normal operation the tractor's external service control lever should be set to the float position - *refer to your tractor handbook for operation instructions*. Float position will allow the tractor's suspension to function in the normal manner.

The front suspension is locked by moving the external service control lever to the centre position. When working for long periods of time with the arm extended to the side, leakage may occur through the tractor's spool valve – this can be rectified by lowering the flailhead to the ground, moving the external service lever to float before returning it to the centre position and resuming work.

**CAUTION** The Axle Locking System must only be activated or used whilst the machine is in normal work mode. NEVER lock the axles of the tractor during transportation or whilst manoeuvring the unit.

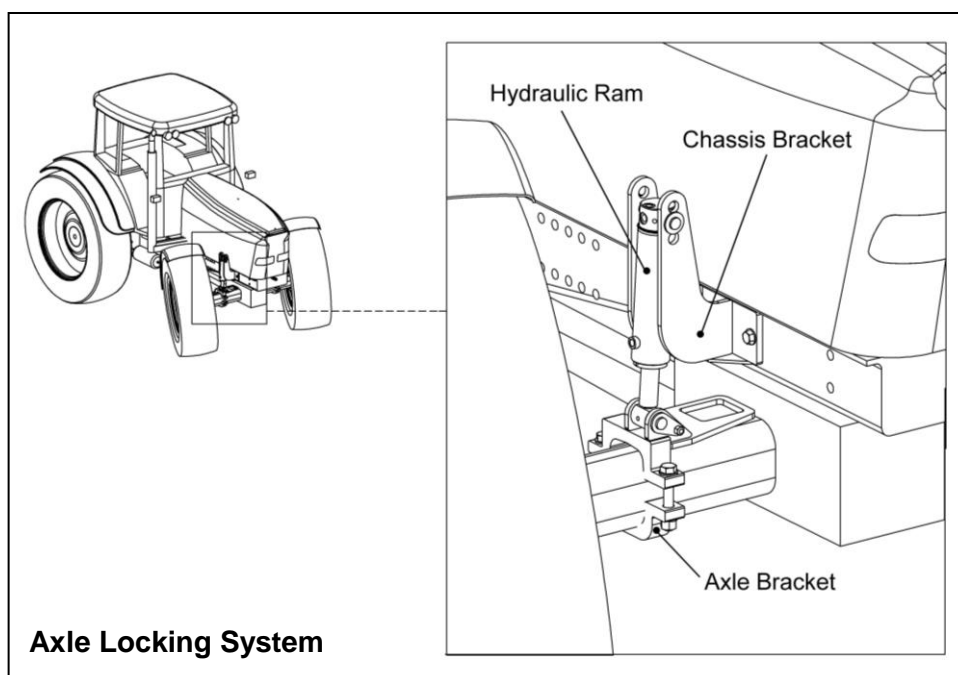

## VEHICLE/ TRACTOR PREPARATION

We recommend vehicles be fitted with cabs using safety glass windows and protective guarding when used with our machines.

**Fit Operator Guard** (part no. 73 13 324) using the hooks provided. Shape mesh to cover all vulnerable areas.

**Remember** the driver must be looking through mesh and/or polycarbonate glazing when viewing the flail head in any working position - unless the vehicle/ cab manufacturer can demonstrate that the penetration resistance is equivalent to, or higher than, that provided by mesh/polycarbonate glazing.

If the tractor has a roll bar only, a frame must be made to carry both mesh and polycarbonate glazing. The operator should also use personal protective equipment to reduce the risk of serious injury such as; eye protection (mesh visor to EN1731 or safety glasses to EN166), hearing protection to EN352, safety helmet to EN297, gloves, filter mask and high visibility clothing.

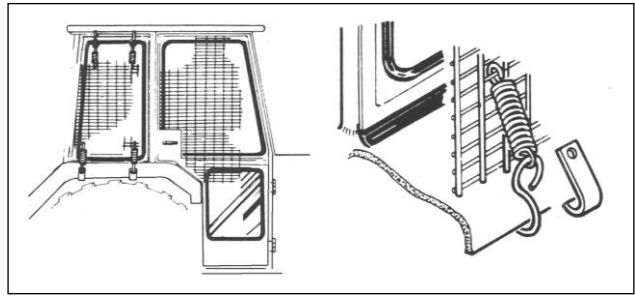

**Vehicle Ballast:** It is imperative when attaching 'third-party' equipment to a vehicle that the maximum possible stability of the machine and vehicle combination is achieved – this can be accomplished by the utilisation of 'ballast' in order to counter-balance the additional equipment added.

**Front weights** may be required for rear mounted machines to place 15% of total outfit weight on the front axle for stable transport on the road and to reduce 'crabbing' due to the drag of the cutting unit when working on the ground.

Rear weights may be required to maintain a reasonable amount of rear axle load on the opposite wheel from the arms when in work; for normal off-ground work i.e. hedge cutting this should be 20% of rear axle weight or more for adequate control, and for ground work i.e. verge mowing with experienced operators, this can be reduced to 10%.

All factors must be addressed in order to match the type and nature of the equipment added to the circumstances under which it will be used – in the instance of Power Arm Hedgecutters it must be remembered that the machines centre of gravity during work will be constantly moving and will differ from that during transport mode, therefore balance becomes critical.

### Factors that effect stability:

- *Centre of gravity of the tractor/machine combination.*
- *Geometric conditions, e.g. position of the cutting head and ballast.*
- *Weight, track width and wheelbase of the tractor.*
- *Acceleration, braking, turning and the relative position of the cutting head during these operations.*
- *Ground conditions, e.g. slope, grip, load capability of the soil/surface.*
- *Rigidity of implement mounting.*

### Suggestions to increase stability:

- *Increasing rear wheel track; a vehicle with a wider wheel track is more stable.*
- *Ballasting the wheel; it is preferable to use external weights but liquid can be added to around 75% of the tyre volume – water with anti-freeze or the heavier Calcium Chloride alternative can be used.*
- *Addition of weights – care should be taken in selecting the location of the weights to ensure they are added to a position that offers the greatest advantage.*
- *Front axle locking, check with tractor manufacturer.*

The advice above is offered as a guide for stability only and is not a guide to vehicle strength. It is therefore recommended that you consult your vehicle manufacturer or local dealer to obtain specific advice on this subject, additionally advice should be sought from a tyre specialist with regard to tyre pressures and ratings suitable for the type and nature of the machine you intend to fit.



# REAR TANK FRAME ATTACHMENT

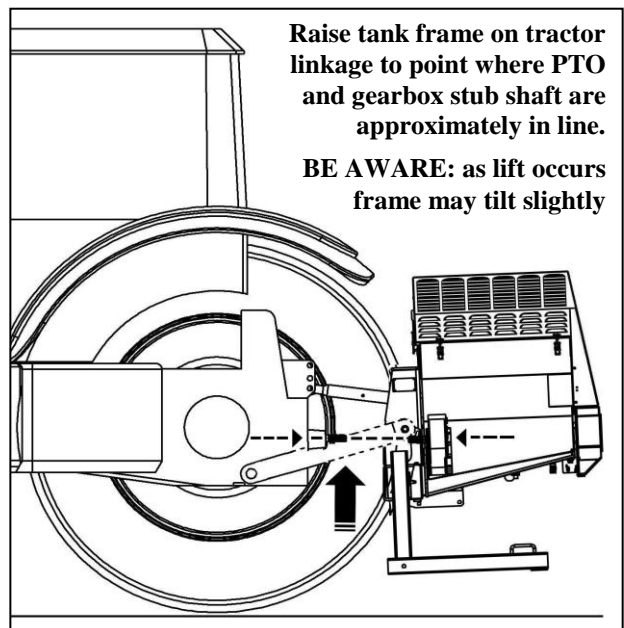
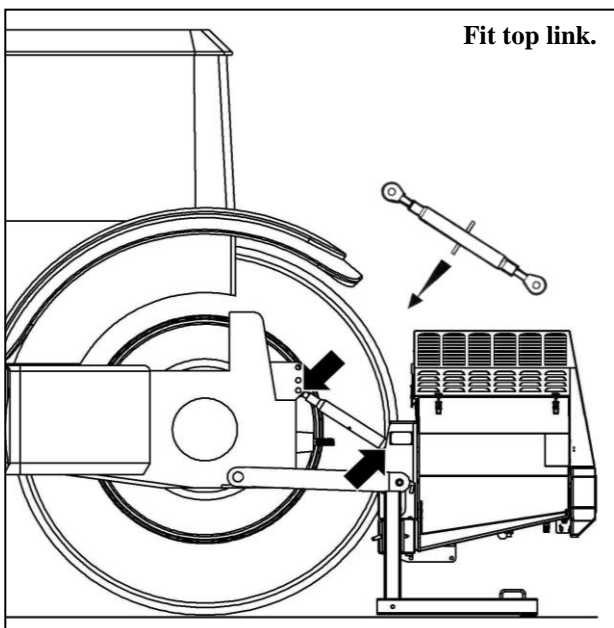
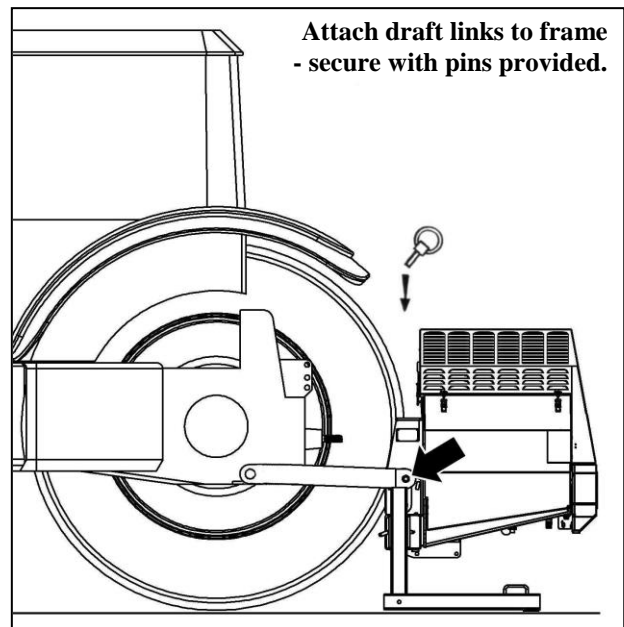
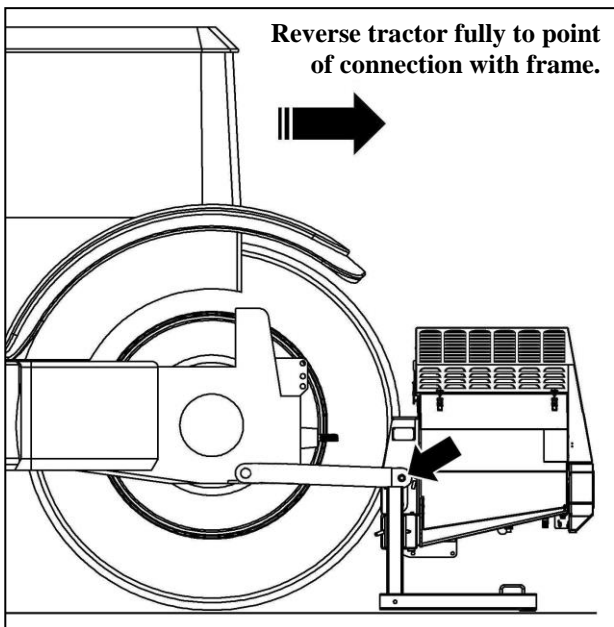
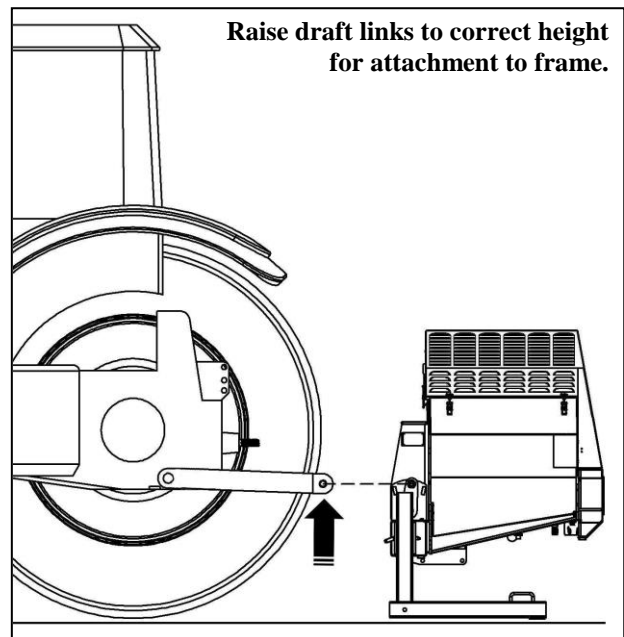
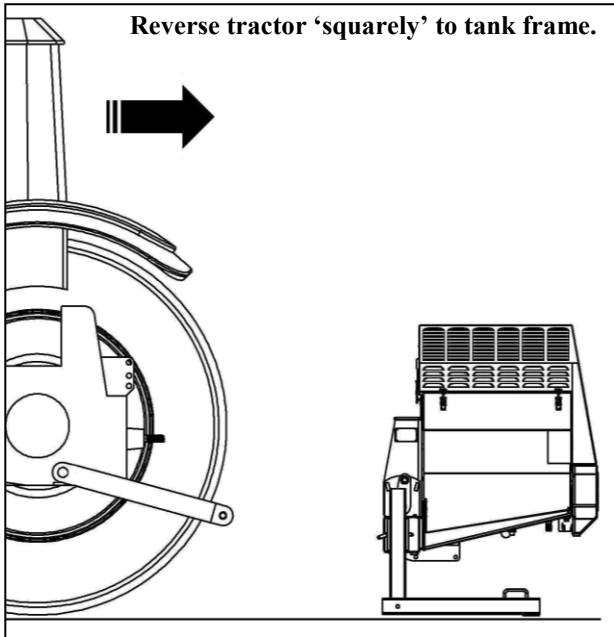

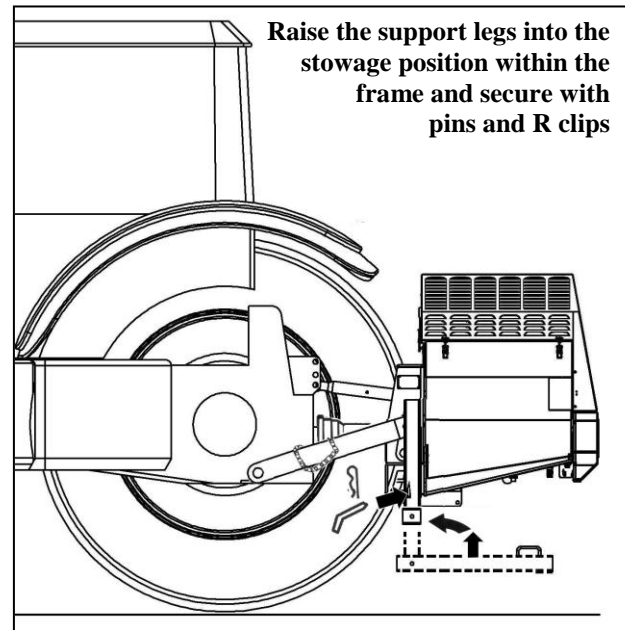
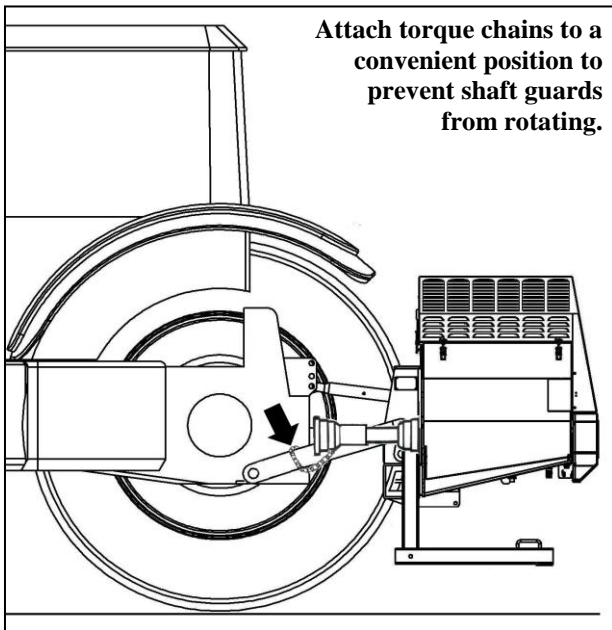
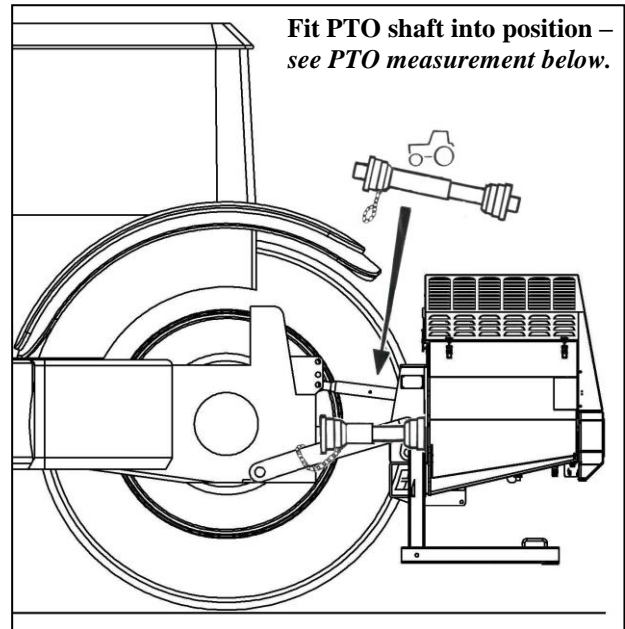
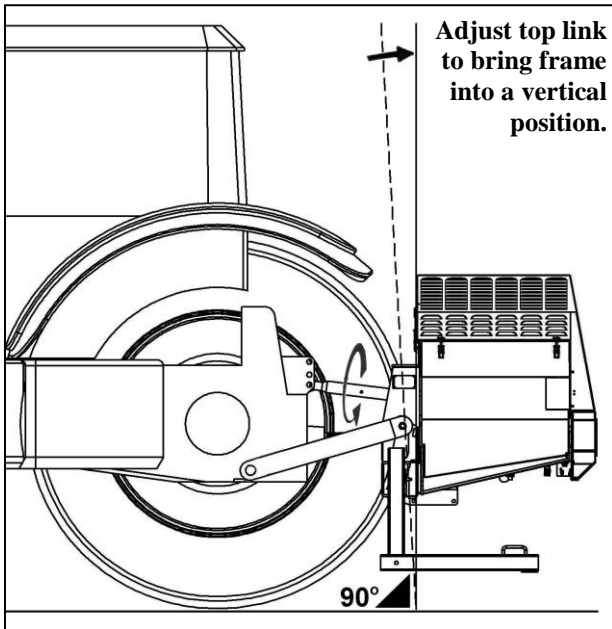

### PTO Measurement

Measure and fit the PTO shaft – refer to following page for details.

### Rear Tank Frame Removal

Removal of the rear tank frame is a reversal of the above procedure.

## PTO DRIVESHAFT INSTALLATION

The PTO driveshaft attaches between the tractor and the machine gearbox to transfer the power required to run and operate the machine – it is important to achieve the correct shaft length to avoid risk of it ‘bottoming out’ when raising or lowering the machine.

The procedure for measuring and cutting the shaft is as follows:

### Measuring the PTO Shaft

With the machine attached to the tractor in the working position measure the horizontal distance ‘A’ from the tractor’s PTO to the input shaft on the machine’s gearbox and subtract 75mm (3”) – *this figure is the required shaft length.*

Place the fully closed PTO shaft on the ground and measure its overall length, if the shaft is shorter than the required length you can use it without the need to shorten - *providing it allows for a minimum 150mm (6”) overlap when fitted.*

If the shaft is longer subtract the required shaft length plus an additional 75mm (3”) - *the resulting figure is the excess length that will need to be removed from each half of the shaft.*

### Cutting the PTO Shaft

Separate the two halves and using the measurement obtained above shorten both the plastic guarding and the inner steel profile tubes of each shaft by this same amount. De-burr the cut tubes with a file to remove rough or sharp edges and thoroughly clean to remove swarf before greasing, assembling and fitting the shaft.

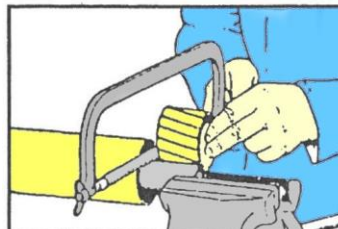
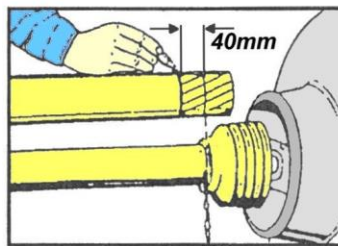
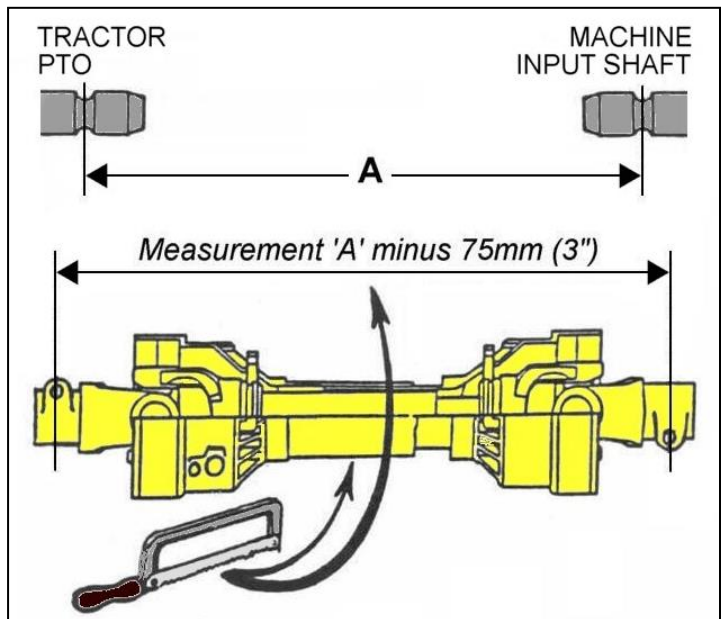

## NOTICE

For subsequent use with different tractors the shaft should be measured again to check suitability – *there must be a minimum shaft overlap of 150mm (6”).*

### Maintenance

To increase the working life of the PTO shaft it should be periodically checked, cleaned and lubricated – *refer to the PTO maintenance section for further details on this subject.*

## FLAILHEAD ATTACHMENT

For ease of attachment and safety this procedure is best performed on a firm level site. With the tractor parked alongside the flailhead operate the controls of the machine to position the pivot bracket of the machines head angling mechanism directly behind flailhead with the base of the hose tray (or junction bracket) parallel to the ground. Manoeuvre the flailhead backwards on its roller until the heads attachment bracket is adjacent to the machines pivot bracket. Fit the 4 attachment bolts through the brackets from the arm side - *if the holes are mis-aligned carefully operate the angling ram until the holes correspond*.

**WARNING:** Ensure all persons remain at a safe distance whilst operating the angling function as the geometry of the head angling mechanism produces several pinch risk areas.

With the attachment bolts correctly located through the brackets fit the self-locking nuts and tighten alternately until the brackets are drawn flush before finally tightening them to a torque setting of 203Nm (150ft.lbs).

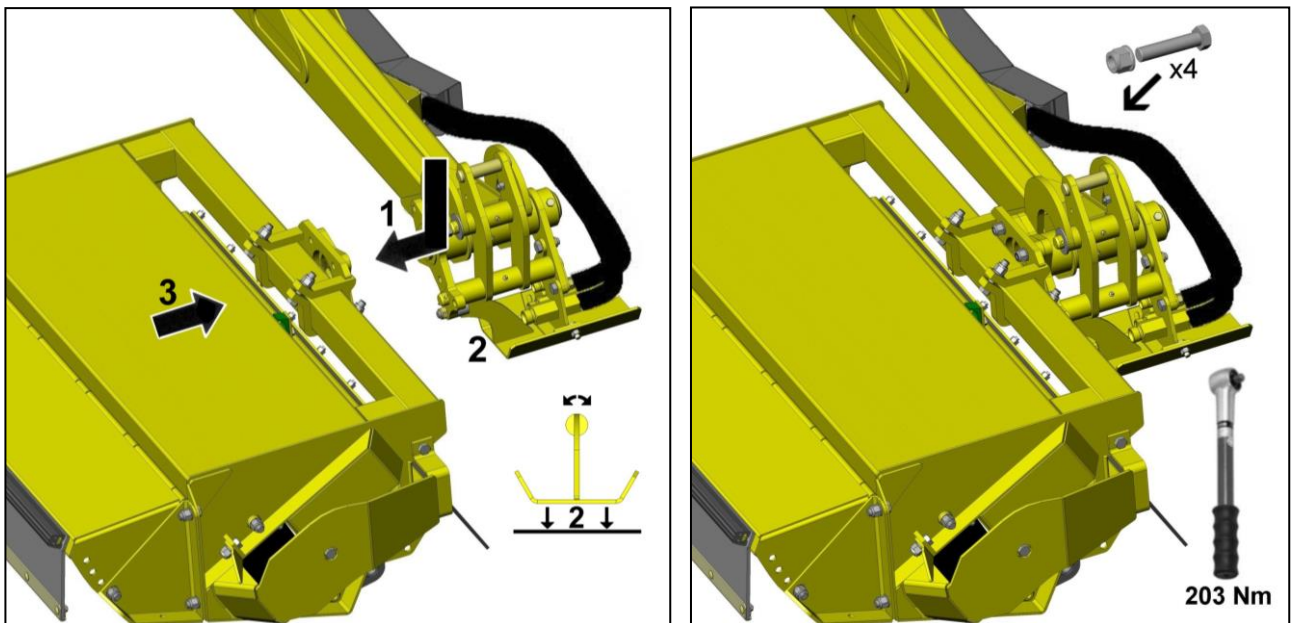

*Note: The illustrations used here are for example purposes only and may differ from the actual machine.*

### Flailhead Hose Attachment

With the flailhead attached to the machine the hydraulic hoses can now be connected – *refer to the illustrations opposite*. Upper port 'A' on the motor connects to junction bracket point 'A' on the arm and lower port 'B' on the motor connects to junction bracket point 'B' on the arm.

**Note:** If a hose tray is already fitted to the arm it will need to be removed to allow the hoses to be connected to the junction bracket – ensure the hose tray is replaced once the hoses have been connected.

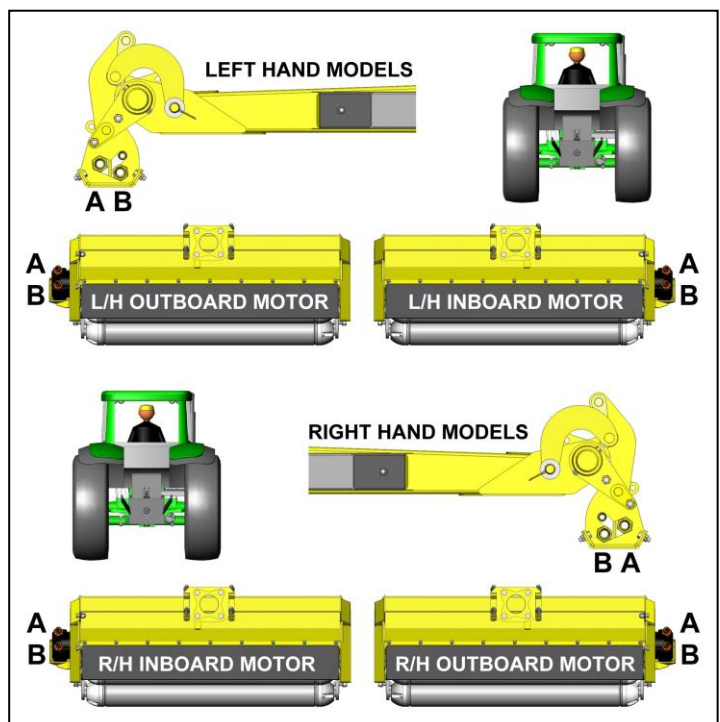

## DETACHING THE ARM UNIT

### Support & Storage Frame

Removal of the Mid-Mount arm unit necessitates the use of a purpose-built support and storage frame that ensures the unit is safely and securely supported throughout the removal process and during its storage – NEVER attempt to remove or store the arm unit without the use of this frame.

### Attaching Arm Unit to Support and Storage Frame

It is vital during attachment or detachment of the arm unit to the support frame that both the tractor and frame are sited on firm level ground.

With the machines arms and flail head positioned at right angles to the tractor position the unit alongside the support frame with the flail head directly above its support points on the frame with the dipper arm vertical – *ensure that the distance between tractor and frame is sufficient to allow the tractor to be driven away freely without fouling the arm unit once the machine has been removed.*

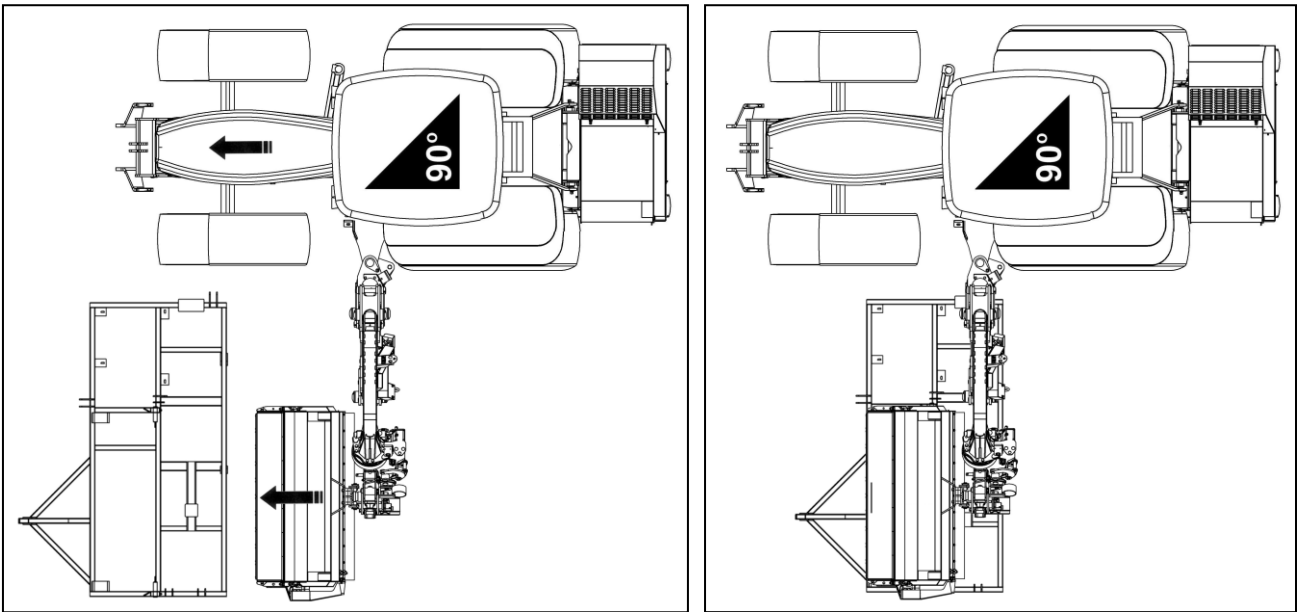

With the flail head positioned above the support frame as shown in the illustrations below, remove the locking pins from the latches located each end of the rear roller. *Note that the head is positioned with the latches slightly forward of their connection points on the support frame as shown in the illustration on the left; this is to allow them to correctly locate on the frame when the head is lowered.*

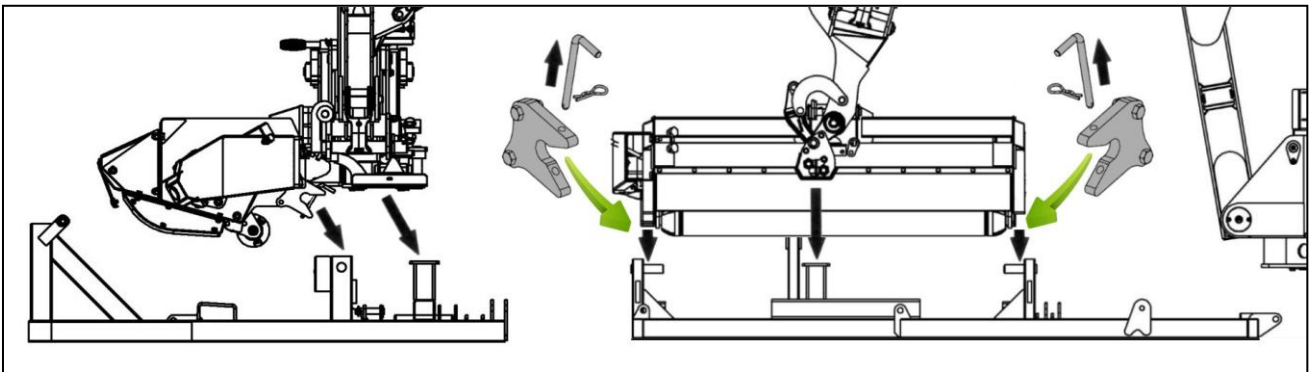

Lower the flail head onto the frame allowing its latches to locate on their connection points and the head to rest on the support points. Replace latch locking pins and secure with 'R' clips.

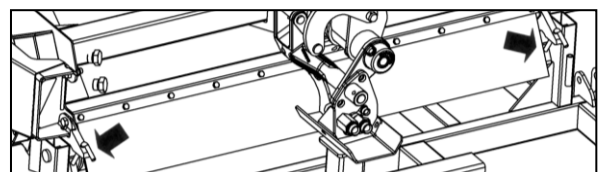

Secure the machine firmly to the frame with angle braces provided and fit the tension bar on the rotator unit – refer to illustrations below.

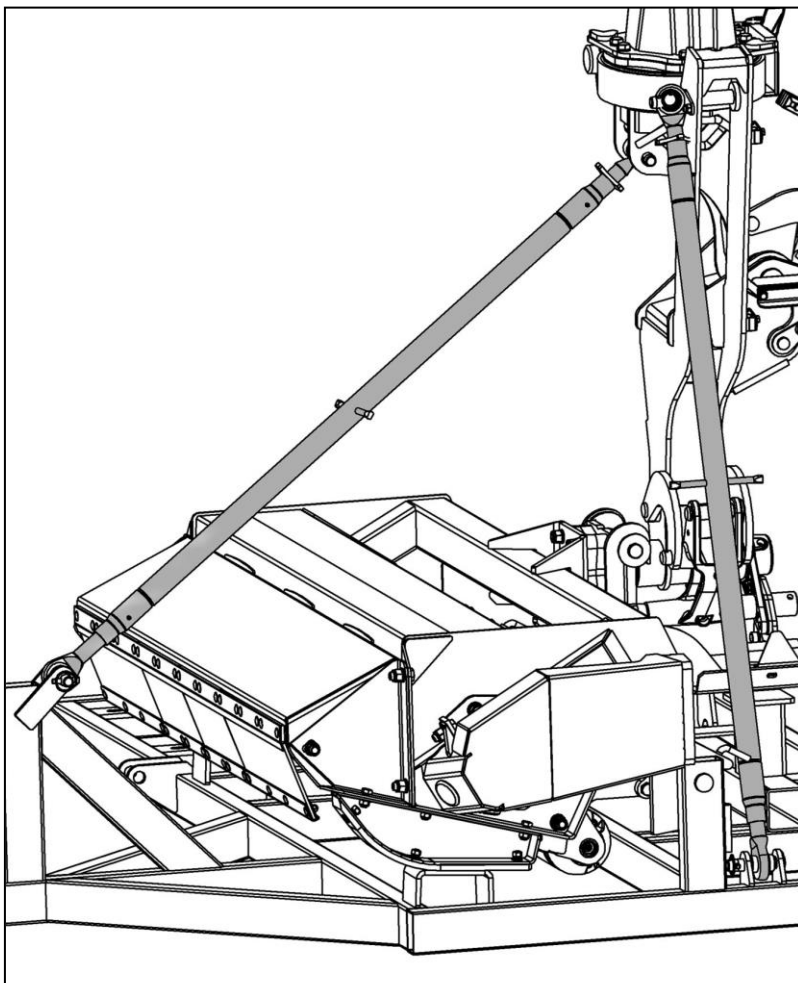
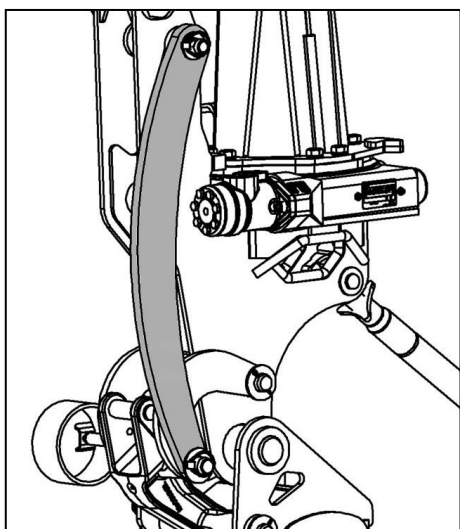
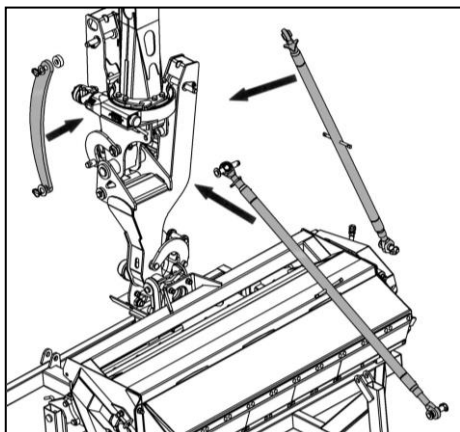

### Subframe Connection Mechanism

The unit attaches to the tractor via a fixed sub-frame mounted on the underside of the tractor; the machine is subsequently mounted onto the subframe with nuts and bolts on the lower mounting position and dual latches on the upper mounting position.

Detachment of the machine requires removal of the lower mounting bolts prior to the latches being raised into their open position.

Releasing the machine from the subframe must only be performed when the machine is correctly secured to its storage/support frame and is the last task before beginning the final removal procedure.

Refer to illustration opposite the location of fixings and operating method for the latch system.

The latch levering handle is stowed in the location shown below when it is not in use.

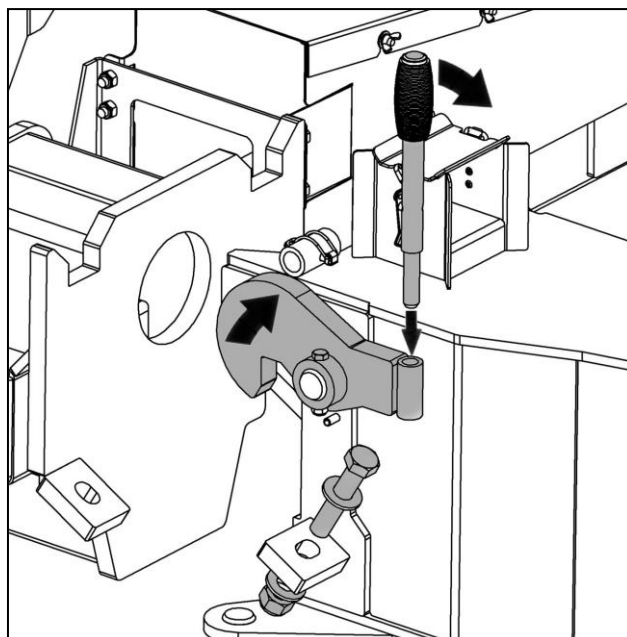
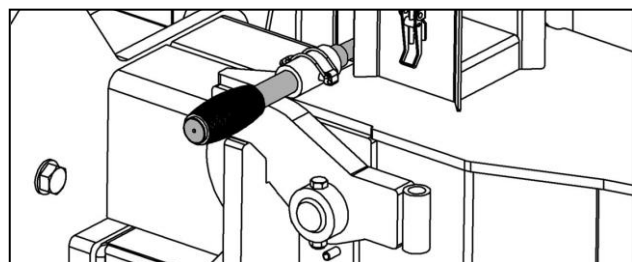

## Detaching the Arm Unit

Loosen and remove the two bolts, nuts and washers that secure the lower part of the intermediate frame to the tractor's subframe – refer to previous page for details.

The arm unit is now ready to be detached from the tractor by utilisation of the machines hydraulic rams – *great care should be adopted when carrying out this procedure ensuring that bystanders are kept at a safe distance.*

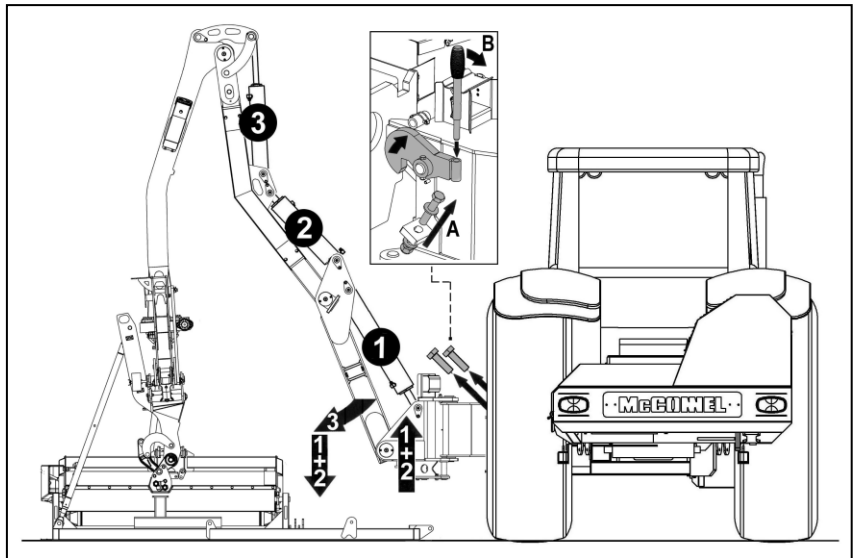

The latches of the intermediate frame attach over the top of the subframe, therefore the intermediate frame may need to be raised slightly to take the laden weight off the latches before they can be fully released - this is done by operation of the 1<sup>st</sup> and 2<sup>nd</sup> rams of the machine – Note: only raise the unit initially to a height that will take the weight off the latches sufficient for their release.

With the latches placed in their fully open position, carefully operate the machines 1<sup>st</sup>, 2<sup>nd</sup> and 3<sup>rd</sup> rams in a slow sequence that will allow the intermediate frame to be manoeuvred up, out and away from the tractor – take care not to raise the intermediate frame too high or it will risk fouling on the tractor components above.

When the machine is clear of the subframe the machine's arms can then be compactly folded into the confines of the support frame by operation of the 3<sup>rd</sup> ram with additional use of the 1<sup>st</sup> and 2<sup>nd</sup> rams. Ensure the finished storage position is one that will offer maximum stability of the unit – see *illustration opposite.*

With the arm unit correctly parked on the support frame, the machines hydraulic hoses can then be disconnected from the quick release couplings and carefully withdrawn from their location. Stow all the hose lines neatly, clear of the ground and away from risk of accidental damage.

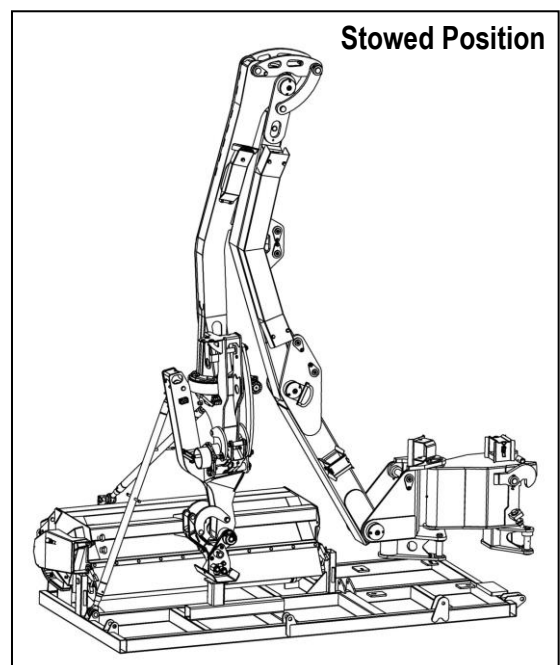

## Re-attachment of Arm Unit

Re-attachment of the arm unit to the tractor is a basic reversal of the removal procedure.

### **CAUTION**

*As with all tasks of this nature safety and caution at all times should be of primary importance to avoid risk of personal injury and/or damage to machinery.*

## STORAGE

---

### **Machine Storage**

If the machine is to be left standing for an extended period of time, lightly coat the exposed portions of the ram rods with grease. Subsequently, this grease should be wiped off before the rams are next moved. Wherever possible, storage of the machine should ideally be in a clean dry location where it is protected from the elements.

Store control units indoors in a safe dry location where they are not at risk of being accidentally damaged.



# HYDRAULIC OIL REQUIREMENTS

## Hydraulic Oil Reservoir

Fill the tank with oil selected from the chart below or a good quality equivalent to a point where the level is between the minimum and maximum marks on the tank gauge. When the machine is initially run the level will drop as the oil is drawn into the circuit - *top back up as required to the correct level on the gauge.*

Always use clean receptacles when handling and transferring oil to avoid moisture or dirt contamination that can damage components and/or reduce machine performance.

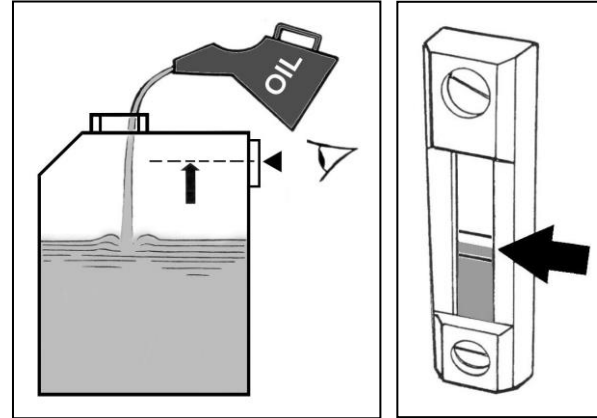

### NOTICE

Refer to the maintenance section for further information on the subject of hydraulic oil and system filtration.

## Reservoir Capacity

The oil tank capacity of the machine is approximately **240 Litres**.

## Recommended Hydraulic Oils

For initial filling of the oil reservoir, periodic oil changes and replenishment purposes the following hydraulic oils, or a good quality equivalent are recommended.

### NOTICE

Only use oils that are ISO 18/16/13, NAS7, or cleaner.

## Recommended Oil

Supplier	Cold or Temperate Climate	Hot Climate
<b>BP</b>	<i>Bartran 46</i> <i>Energol HLP-HM 46</i>	<i>Bartran 68</i> <i>Energol HLP-HM 68</i>
<b>CASTROL</b>	<i>Hyspin AWH-M 46</i>	<i>Hyspin AWH-M 68</i>
<b>COMMA</b>	<i>Hydraulic Oil LIC 15</i>	<i>Hydraulic Oil LIC 20</i>
<b>ELF</b>	<i>Hydrelf HV 46</i> <i>Hydrelf XV 46</i>	<i>Hydrelf HV 68</i>
<b>ESSO</b>	<i>Univis N 46</i>	<i>Univis N 68</i>
<b>FUCHS</b> (UK/Non UK markets*)	<i>Renolin 46</i> <i>Renolin HVZ 46</i> <i>Renolin CL46/B15*</i> <i>Renolin AF46/ZAF46B*</i>	<i>Renolin 68</i> <i>Renolin HVZ 68</i> <i>Renolin CL68/B20*</i> <i>Renolin AF68/ZAF68B*</i>
<b>GREENWAY</b>	<i>Excelpower HY 68</i>	<i>Excelpower HY 68</i>
<b>MILLERS</b>	<i>Millmax 46</i> <i>Millmax HV 46</i>	<i>Millmax 68</i> <i>Millmax HV 68</i>
<b>MORRIS</b>	<i>Liquimatic 5</i> <i>Liquimatic HV 46</i> <i>Triad 46</i>	<i>Liquimatic 6</i> <i>Liquimatic HV 68</i> <i>Triad 68</i>
<b>SHELL</b>	<i>Tellus 46</i> <i>Tellus T46</i>	<i>Tellus 68</i> <i>Tellus T68</i>
<b>TEXACO</b>	<i>RandoHD 46</i> <i>Rando HDZ 46</i>	<i>Rando HD 68</i> <i>Rando HDZ 68</i>
<b>TOTAL</b>	<i>Equivis ZS 46</i>	<i>Equivis ZS 68</i>

## FITTING CONTROL UNIT IN CAB

### Revolution Proportional Controls

Revolution proportional controls comprise of 2 units; the main control box or control screen (respectively), and the armrest control unit. The control box/screen is supplied with a mounting bracket and suction cup assembly that allows the unit to be mounted on the window of the tractor cab – ensure the surface used is clean and dry and that the unit is mounted in a position where it does not obstruct operator vision. The armrest unit is designed to slide over the armrest of the tractor seat and is held in place with the fixing straps provided. Alternately, a mounting bar is supplied with Revolution controls that can be used should a more permanent installation be required; when fitting the latter ensure that any holes drilled in the tractor cab are clear of important component and electrical wiring and should not be located in any area where it could affect the safety structure of the cab. The power supply cable should be connected directly to the tractor's battery - do not use cigarette lighter type connections as these prove to be sporadic and unreliable for control applications. Control units are 12 volt DC operated; the red lead is positive (+) and the black lead is negative (-).

## PRE-OPERATIONAL CHECKS

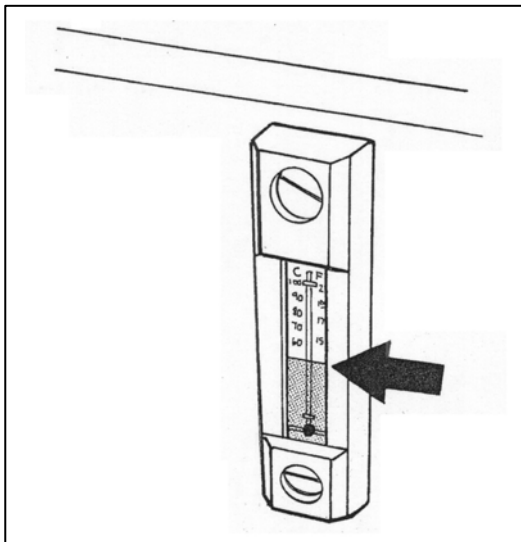

**CHECK: Oil level in Hydraulic Tank.**

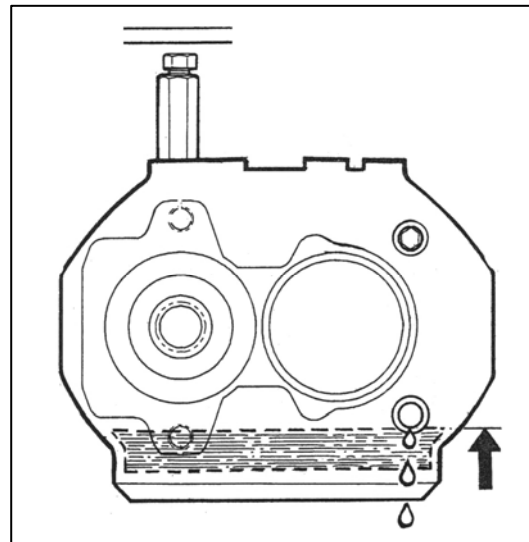

**CHECK: Oil level in Gearbox.**

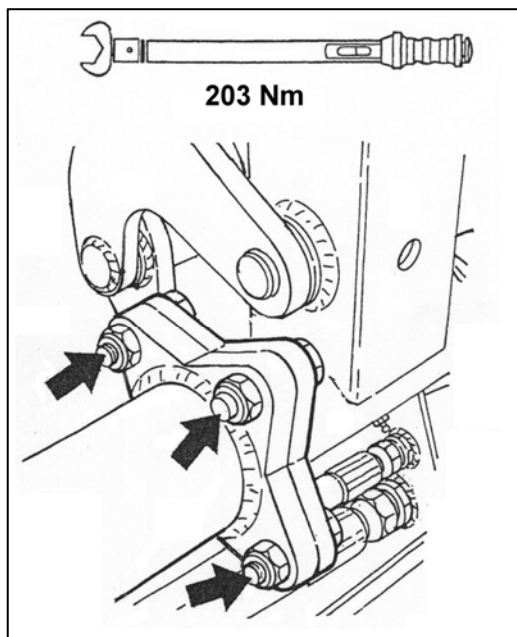

**CHECK: All bolts are tight and the flail head mounting bolts are torqued to the figure stated.**

## RUNNING UP PROCEDURE

---

### **⚠ CAUTION**

Before initial use of a new machine, all lubrication points must be greased and the gearbox and oil tank levels checked and where required topped up before attempting to use the machine. Refer to maintenance section for details.

The procedure for starting the machine is as follows:

- Ensure that the rotor control valve is in 'Stop' position.
- Start tractor and engage PTO - *allow the oil to circulate through the return line filter for about 5 minutes without operation of the armhead control lever.*
- Carefully operate the armhead controls through their complete range ensuring that all movements are functioning correctly.
- Place the flail head at a safe attitude and move the rotor control to 'Start' position, after initial fluctuation, the rotor should settle to a steady speed.
- Increase PTO speed to approximately 540RPM and run for a further five minutes before disengaging and stopping tractor.
- Check the hose runs and ensure that they are free from any pinching, chaffing, straining or kinks.
- Check the oil level in the tank and top up as necessary.

## EMERGENCY STOPPING

---

In all emergency situations machine operation and functions must be stopped immediately; **Stop PTO operation** using the tractor controls then immediately kill electrical power to the machine using the **Off (Emergency Stop)** switch on the machine's control unit.

### **⚠ WARNING**



#### **Auto-Reset Machines**

When the Auto-Reset feature is active the machines arm set is capable of unintentional movement even when the PTO is switched off and stationary. Always ensure that electrical power to the machine is switched off using the **Off (Emergency Stop)** switch on the machine's control unit in emergency situations and/or when the machine is not being operated.

### **⚠ WARNING**



#### **Cable Operated Machines**

In certain conditions, and/or if the Auto-Reset feature is active, the arm sets on cable operated machines possess the potential to move unintentionally, even when the PTO is switched off and stationary, if the levers were to be accidentally operated. Care must be adopted to avoid any movement of the levers when the machine is not being operated. Ensure arm sets are lowered fully to the ground when the machine is parked up or not in use.

## OPERATION

---

### Operator Safety

During operation all the tractor windows should be kept firmly closed with the exception of the rear window which may be opened only to the extent that is sufficient to allow entry of electrical or operating cables for the machine into the cab.

Should the tractor not be fitted with a 'quiet' cab ear defenders must be worn at all times, failure to heed this warning may result in permanent damage to hearing.

Although in normal circumstances a working machine or rotating parts should never be approached it is an additional wise precaution to avoid wearing loose or flapping clothes especially scarves and neckties whilst in close proximity to a machine.

The operator should continually guard himself and others from complacency that can arise from familiarity. Never attempt to take 'short cuts', always follow the correct procedures diligently and abide by the restrictions imposed by safety considerations.

**REMEMBER: there is only one right way - the safe way!**

### NOTICE

#### Operator Controls - Revolution Control System

The following page shows the default controls for armhead operation of this particular machine; this information should be used in conjunction with the Revolution Controls manual issued with the machine which contains full information relating to operation and customisation of the controls.

It is vital that all users read and fully understand all relevant operation manuals for this product in order to fully understand all aspects of the machine with particular regard to safe and correct operation of the machine.

#### Rotor Operation

For rotor operation refer to the controls operation manual for the machine – *see above*.

### ⚠ WARNING



**When the rotor is switched off it will continue to 'freewheel' under its own momentum for up to 40 seconds before finally coming to a standstill – do not leave the tractor cab or attempt to approach the flailhead until the rotor has stopped turning completely.**

# OPERATOR CONTROLS – PA8085M MID-MOUNT MODEL

The illustration below identifies the default controls for the PA8085M Mid-Mount machines; for customisation options refer to the Operation Manual for McConel Revolution Controls.

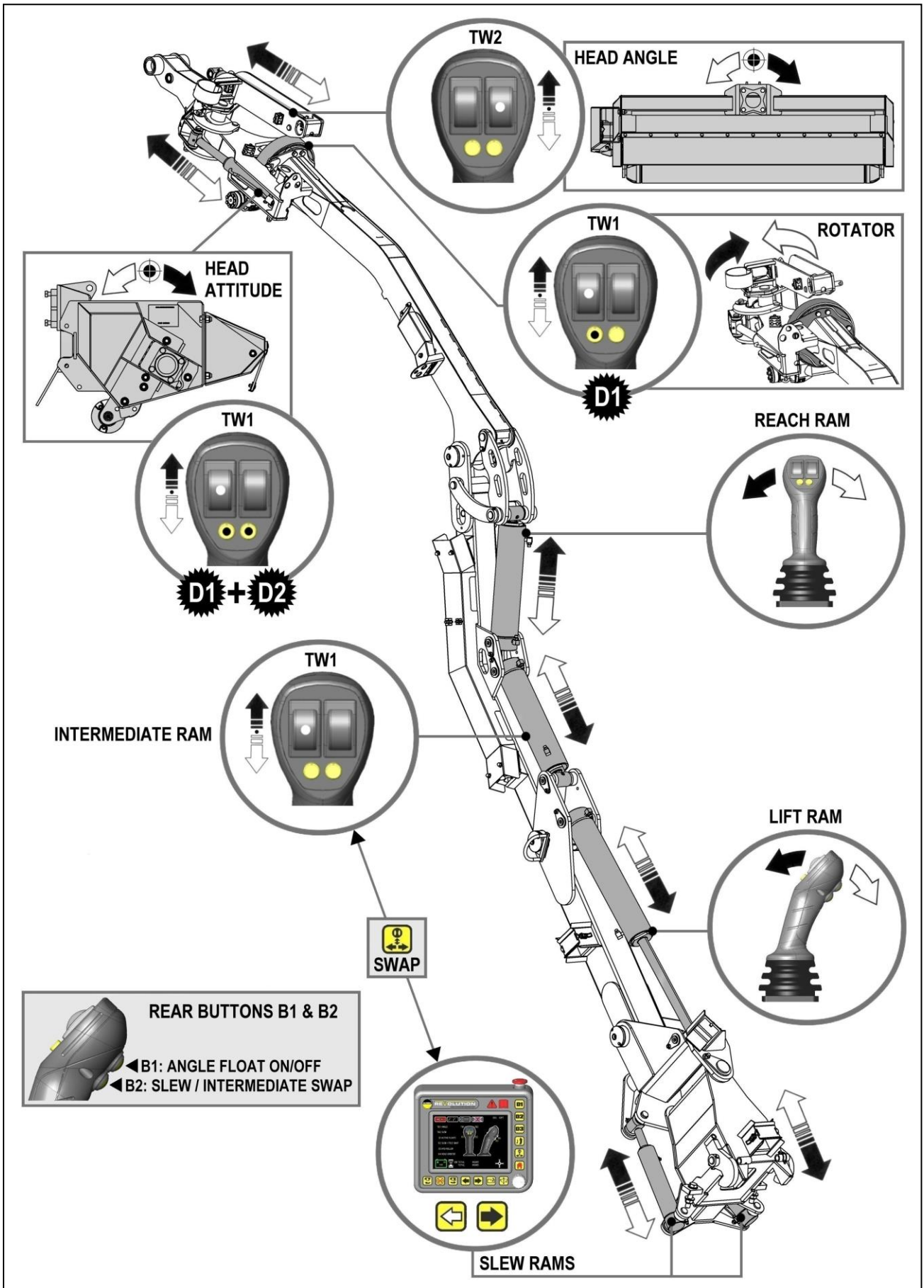

## PREPARATION

### READ THE BOOK FIRST

It is recommended that users practice operating the machine in an open space without the rotor running until they are fully familiar with all aspects of both control and operation of the machine.

#### **CAUTION**

Care must be taken when working with the flail head close in as it can come into contact with the tractor.

#### **Running In a New Machine**

For the first day's work it is recommended that tractor forward speed is restricted to 3 km/hr maximum - this will allow machine components to 'bed in' and allow the operator to become familiar with the controls and their response under working conditions whilst operating at a relatively slow speed. If possible, select a first days work that will provide a majority of light to average cutting with only occasional heavy duty work - *during this period check that nuts and bolts are tight after: one hour, four hours and again at the end of the day.*

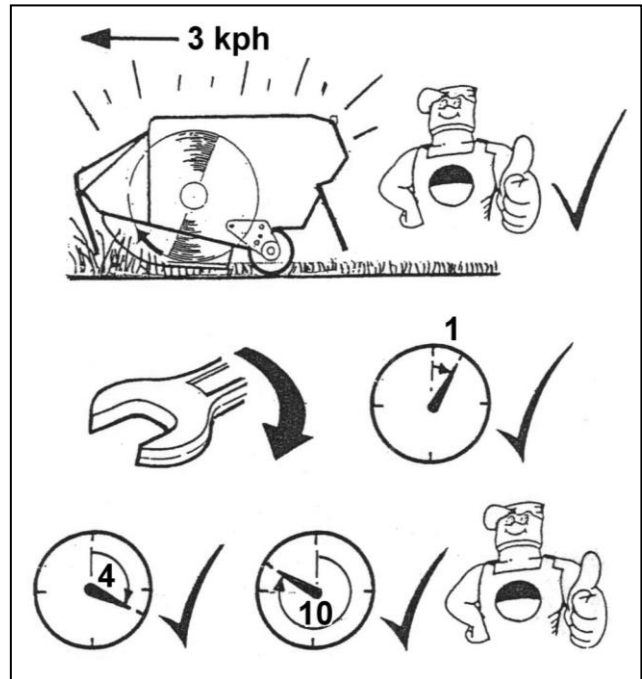

#### **Cutting Precautions**

Inspect the work area, remove any hazardous materials and note any immovable objects - *it may also be a wise precaution to indicate these hazards with a visible marker than can be easily seen from the tractors operating position.*

If the type of work being undertaken makes this important precaution impractical, always maintain a high degree of alertness and observation and restrict the tractors forward motion to a speed that will allow the operator sufficient time to stop the tractor before contact is made with the hazard.

#### **General Working Practices**

It is the operator's responsibility to develop safe working procedures;

#### **ALWAYS:**

- Be aware of hazards in the vicinity.
- Ensure all guards are in position and in good condition.
- Disengage PTO before stopping the engine.
- Wait until the flail has stopped running before leaving the tractor seat.
- Disengage the PTO, stop the engine and pocket the key before making any adjustments.
- Check frequently that all nuts and bolts are tight.
- Keep bystanders at a safe distance.

## OPERATING SPEEDS

### PTO Operating Speed

The correct PTO speeds for operation of machines are as follows:

**Gear Machines: 500 - 540 rpm (Max)**

**Piston Machines: 800 - 830 rpm (Max)**

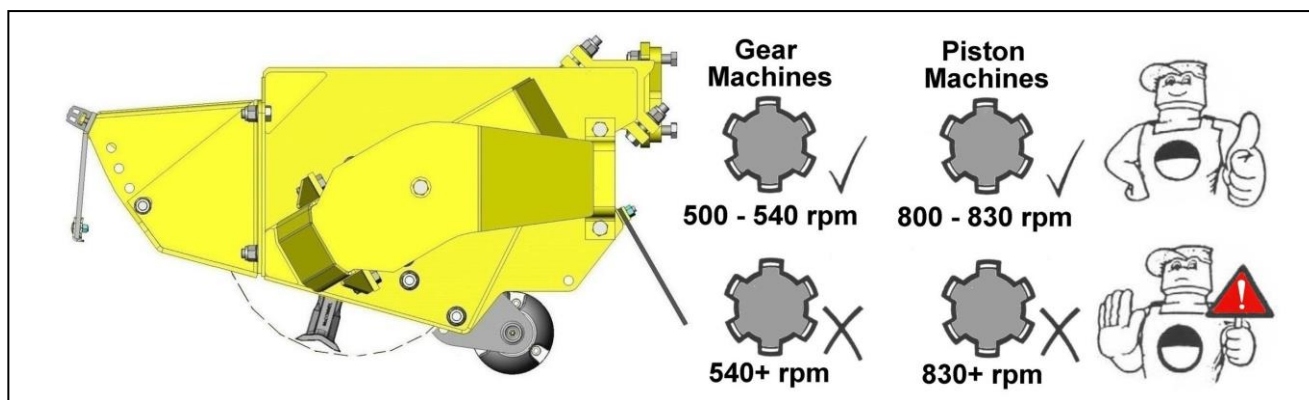

**⚠ WARNING** Damage to the machine may occur if maximum PTO speed is exceeded.

### Engaging Drive

- Ensure the rotor control lever/switch is in the 'stop' position before engaging the PTO.
- Allow the oil to circulate for a minute or so before operating the armhead controls.
- Move the flail head into a safe working position just clear of the material to be cut.
- Increase engine speed to a high idle and start the rotor – after initial 'surging' the rotor will run at an even speed.
- Carefully lower the flail head into the work area and begin work.

### Tractor Forward Speed

The material being cut will determine the tractor forward speed. Forward speed can be as fast as that which allows the flail head sufficient time to cut the vegetation both efficiently and neatly.

If forward speed is too fast this be indicated by over frequent operation of the breakaway system, a fall off in tractor revs and a poor untidy finish to the work leaving ragged uncut tufts and poorly mulched cuttings.

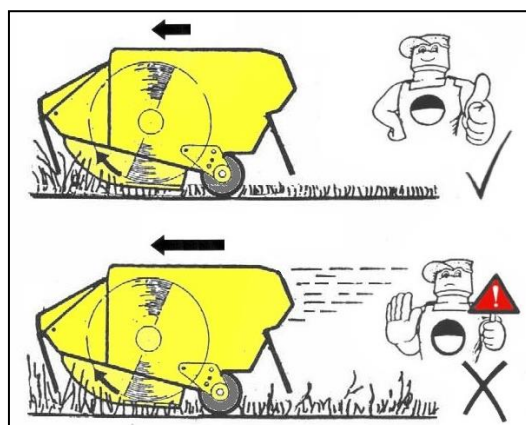

### 'Running In' - New Machines

For the first days work with a new machine it is recommended that tractor forward speed is restricted to 3 km/hr (2 mph) maximum. This will allow machine components 'bed in' and allow the operator to become familiar with the controls and their response under working conditions whilst operating at a relatively slow speed. If possible, select a first days work that affords mainly light to average cutting with occasional heavy duty work – *during this period check the tightness of nuts and bolts every hour, retightening as and when required.*

**First day use - check tightness of nuts & bolts hourly ►**

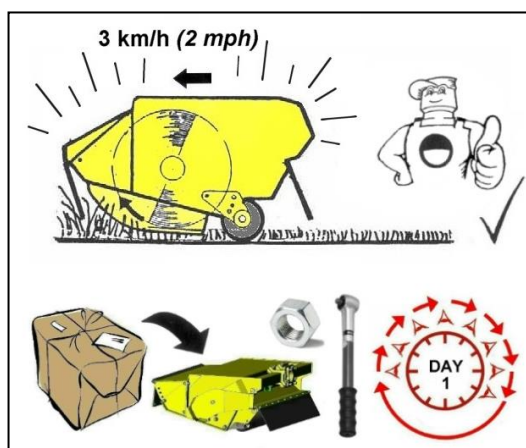

## ANGLE FLOAT

---

Machines are fitted with Angle Float as standard – when activated the feature connects the base and gland circuits of the angle ram to allow free movement of oil in both directions thus allowing the head to automatically angle itself to match the contours of the ground. Refer to controls manual for details of operation.

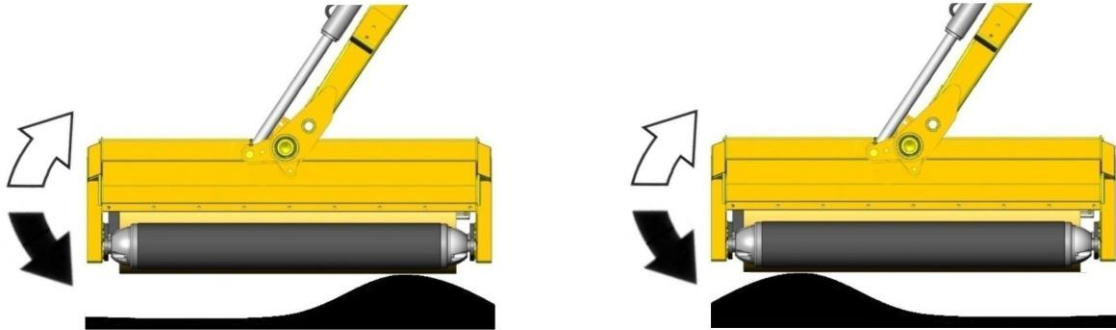

**Angle Float Off – Requires operator input to adjust flail head angle**

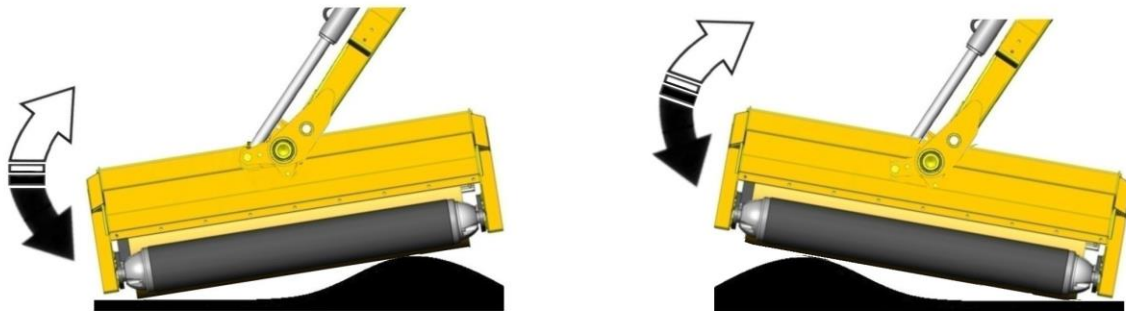

**Angle Float On – Flail head automatically angles itself to match the ground contours.**

### Grass Mowing

It is recommended that both lift float and angle float are used when grass mowing. To ensure maximum visibility of the head during work it is suggested that the 1<sup>st</sup> and 3<sup>rd</sup> rams are used to control the flailhead reach – the 2<sup>nd</sup> ram should be fully or nearly closed. The 2<sup>nd</sup> and 3<sup>rd</sup> rams can be used for the same operation but the operator's visibility of the front of the head and its immediate cutting area may be impaired.



## POWERED SLEW

The machine features a powered arm slewing capability of 138° - from 30° rearwards of the right angle position or forwards of it by up to 108° - the latter, with use of the turnaround kit, makes it possible to work with the flailhead positioned directly in front of the tractor – *caution should be adopted when operating the machine in this position as the flailhead and its immediate cutting area will not be visible from the operator position.*

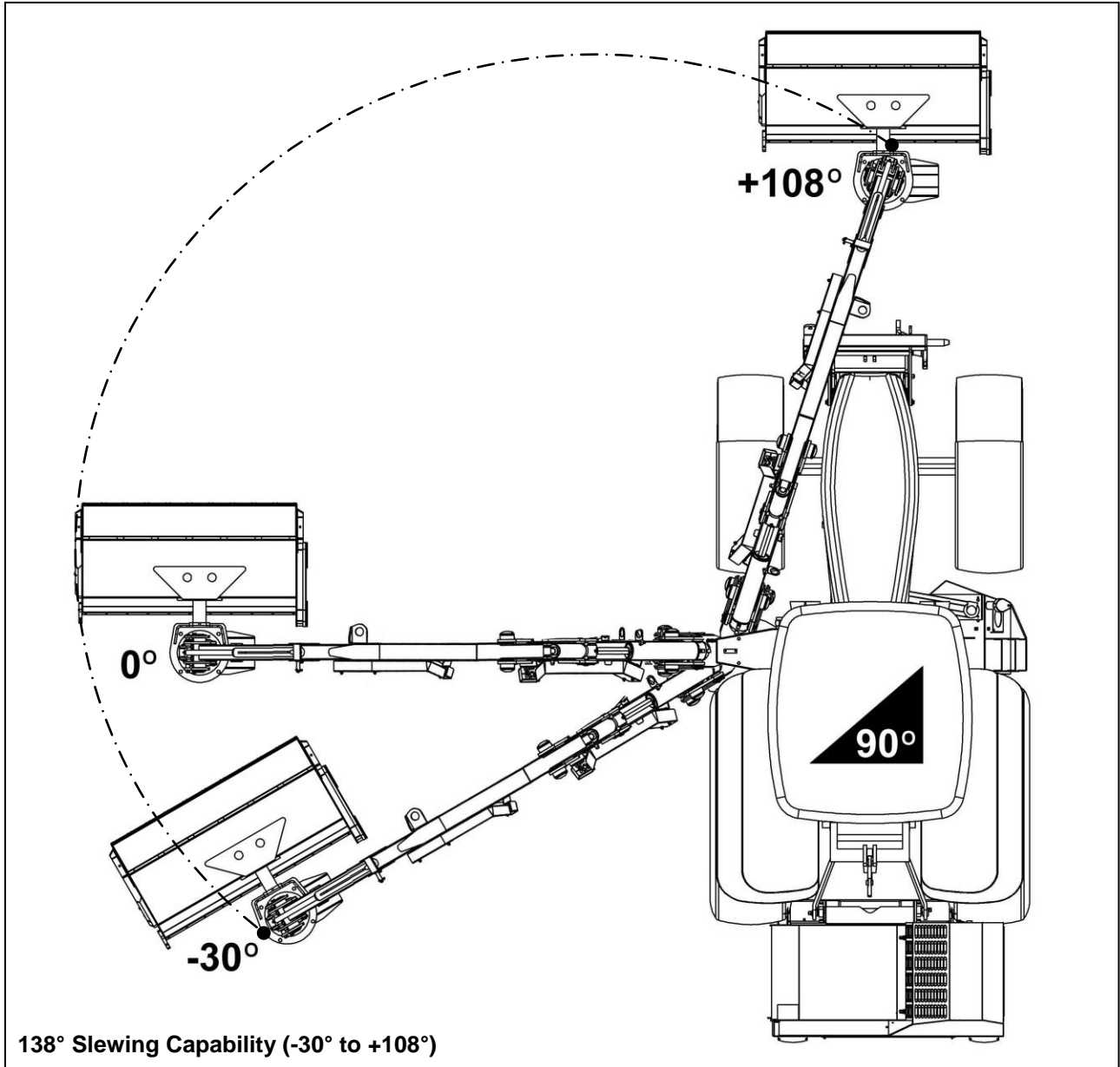

### Operating with 'Slew' Selected

When the slew relief valve setting is exceeded oil is displaced from the slew ram allowing the arm to pivot backwards horizontally and the obstacle to be cleared.

Re-setting the head into the work position is carried out manually by selecting 'Slew Out' on the control assembly.

## POWERED HEAD ROTATION

The flailhead can be rotated in both the horizontal and vertical planes using controls for operation of the rotator and head attitude ram respectively. Both functions are operated by the same thumbwheel and the specific function that operates is dependent on the diverter mode; D1 active allows operation of the rotator function, and D1 & D2 active allows operation of the head attitude function. The functions cannot be operated simultaneously.

## FLAILHEAD

---

### Wire Trap

The flailhead is equipped with a 'wire cutting' edge welded into the underside. This is to ensure that the ends of any wire that may be entwined in the rotor are cut and fall within the confines of the flailhead.

### **⚠ WARNING**

**This plate should not be interfered with in any way.**

Any wire caught in the rotor must be immediately removed (*see below*).

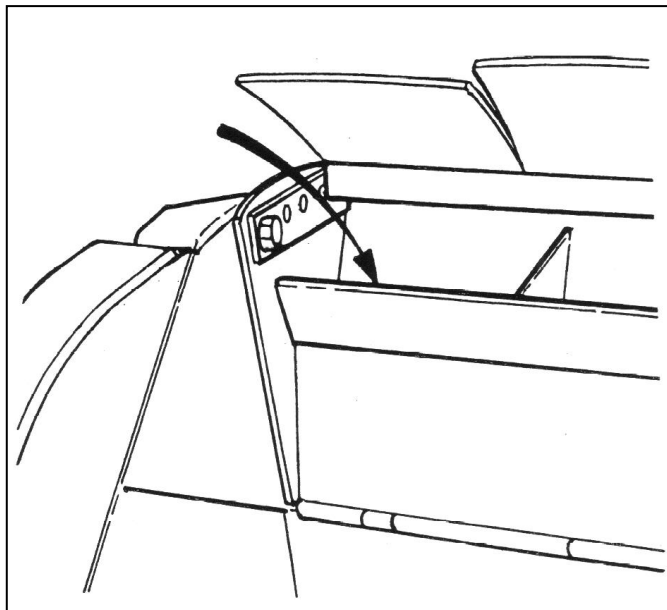

### Removing Wire

- Select rotor '**OFF**' and wait until it has **stopped rotating**.
- **STOP** the tractor and **only then** remove wire.

**NEVER reverse the rotor** in an attempt to unwind any wire.

## HEDGE CUTTING PROCEDURE

Cut the side and bottom of the field side first. This leaves the maximum thickness of hedge on the road side to prevent the possibility of any debris being thrown through the hedge into the path of oncoming vehicles.

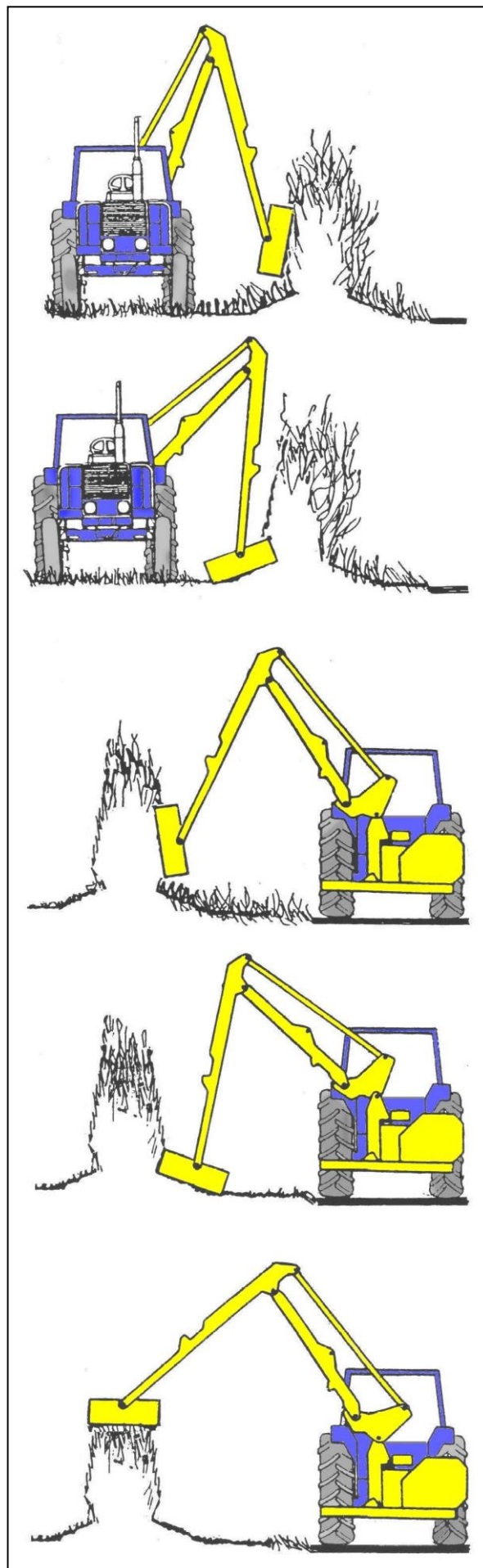

Cut the side and bottom of the road side.

Top cut the hedge to the height required.

## FLAIL TYPES / IDENTIFICATION

---

### Grass Flails

Designed specifically for general mowing activities – low power usage, ideal for cutting materials of low density.

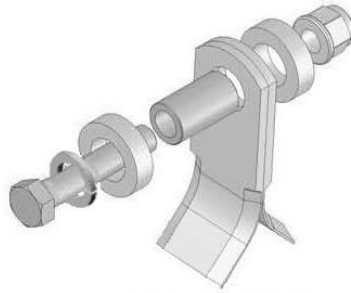

**F10 Grass Flail**  
(Part No. 7190315)

### Universal Boot Flails

Designed for general purpose work - suitable for mowing duties and the cutting of hedges with up to 2 years growth.

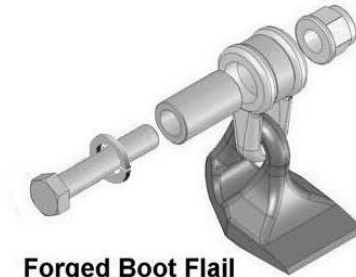

**Forged Boot Flail**  
(Part No. 7190462)

### Hedge Flails

Double edged flail designed specifically for heavy duty hedge cutting - capable of cutting materials up to 75/80mm diameter. Can be used for mowing work where they produce a good finish but will require considerably more power and reduced forward speed when used for this purpose.

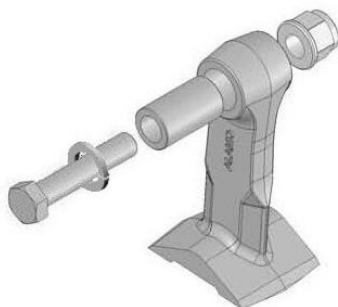

**F10 D.E. Forged Flail**  
(Part No. 41391.02)

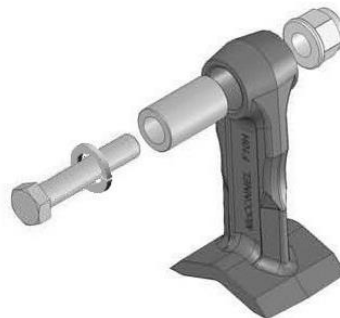

**F10 D.E. Cast Flail**  
(Part No. 7314366D)

**NOTE:** Cast flails are more suitable where the work is predominantly hedge cutting as they maintain a sharper cutting edge – forged versions possess a higher degree of durability and are therefore more suitable where the primary function is mowing work and there is increased risk of hitting foreign objects.

### **Hedge Flails**

Double edged flail designed specifically for heavy duty hedge cutting, capable of cutting materials up to 75/80mm diameter. Can be used for mowing work where they produce a good finish but will require considerably more power when used for this purpose. The flails are fitted with rubber stops for both shaft protection and noise reduction purposes.

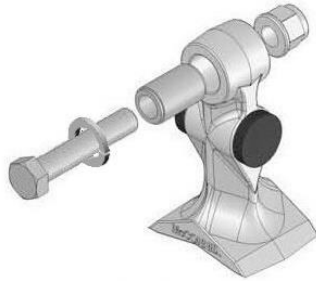

**F16 D.E. Cast Flail**  
(Part No. 21904.02)

### **Competition Flails**

Single edged flail designed specifically for heavy duty hedge and grass cutting, capable of dealing with materials up to 75/80mm diameter. When used for mowing work they produce a better finish and performance than double edged flails requiring less power and increased forward speed.

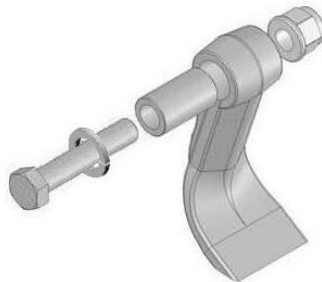

**F10 S.E. Cast Flail**  
(Part No. 7390276)

### **Omega Flails**

Double edged flail for use on 'Omega' rotors only - designed specifically for heavy duty hedge cutting where they are capable of cutting materials up to 75/80mm diameter. Unique rotor design allows the flail to rotate 360° on its pivot protecting the flail on impact with immovable objects. Not suitable for mowing work.

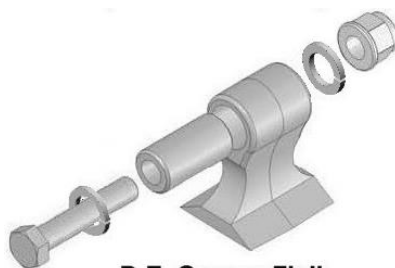

**D.E. Omega Flail**  
(Part No. 7190464)

## TRANSPORTATION CRADLE

A transportation cradle mounted onto the front end of the tractor provides a safe compact storage location for the flailhead during transportation of the machine as well as offering additional support for the arms. The cradle has 2 available positions – transportation position and work position.

For transportation of the machine the cradle should be placed in the down position which allows the flailhead to be positioned onto it with its roller located and supported in the trough of the cradle. The work position is with the cradle raised upwards to the front of the tractor.

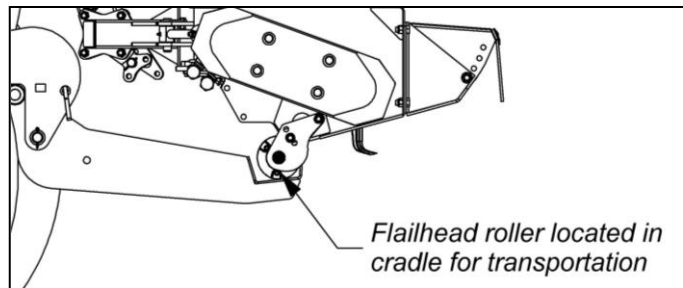

In both positions the cradle must be locked into position using pins and lynch pins in the appropriate locating holes on each side of the cradle. Refer to diagrams below.

Cradle must be locked into whichever position on both sides using pins & lynch pins as indicated below

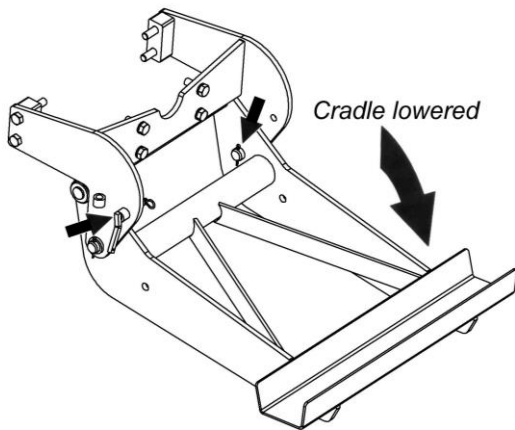

**TRANSPORT POSITION**

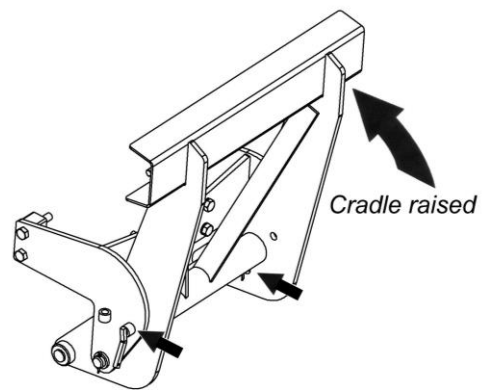

**WORK POSITION**

**Transport Position**

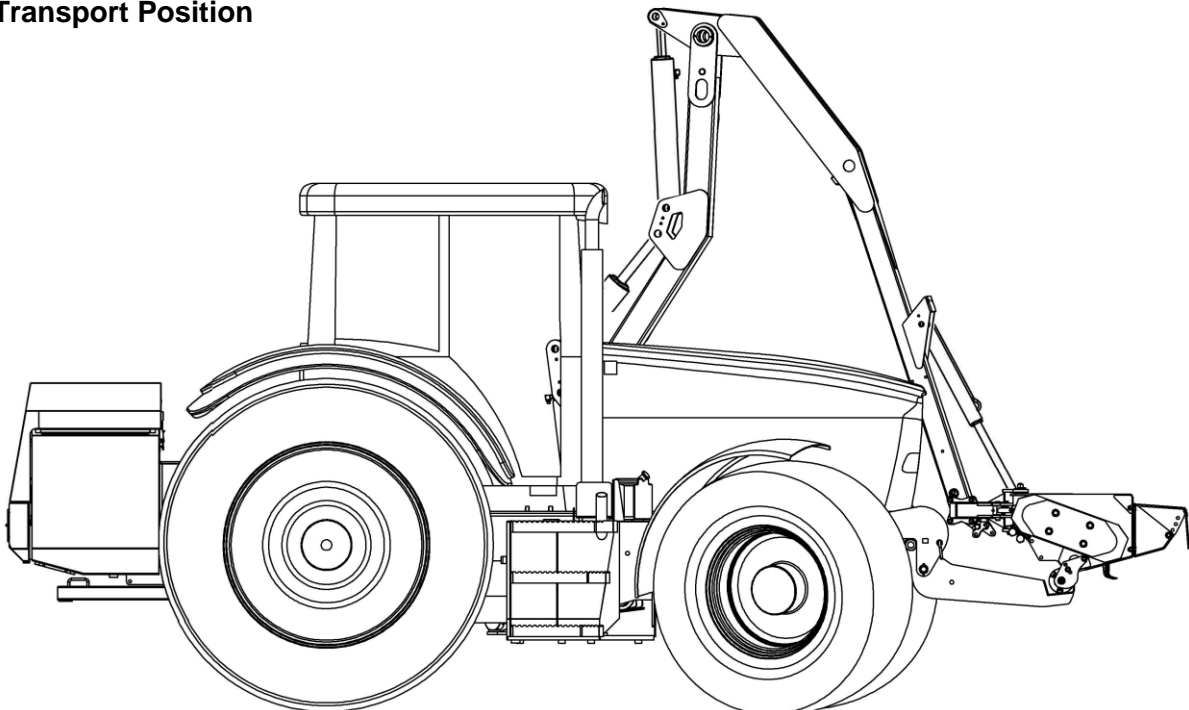

## TRANSPORTING THE MACHINE



When in transport the PTO must be disengaged and the power to the control box switched off.

### Transport Speed

The acceptable speed whilst in transport will vary greatly depending upon ground conditions; the maximum recommended speed is < 20mph. In any conditions avoid driving at speeds that will cause exaggerated 'bouncing' - this may create undue strain on the machine and tractor mounting points.

### Transport Height

The approximate height of the machine in the transport position is 3.9m but this will vary depending on the ride height of the driving unit to which the machine is attached. It is the responsibility of the operator to be fully aware of the height of the machine they are operating at all times and must exercise care when working or manoeuvring under low obstacles such as bridges, building etc. and with extreme caution near power lines.

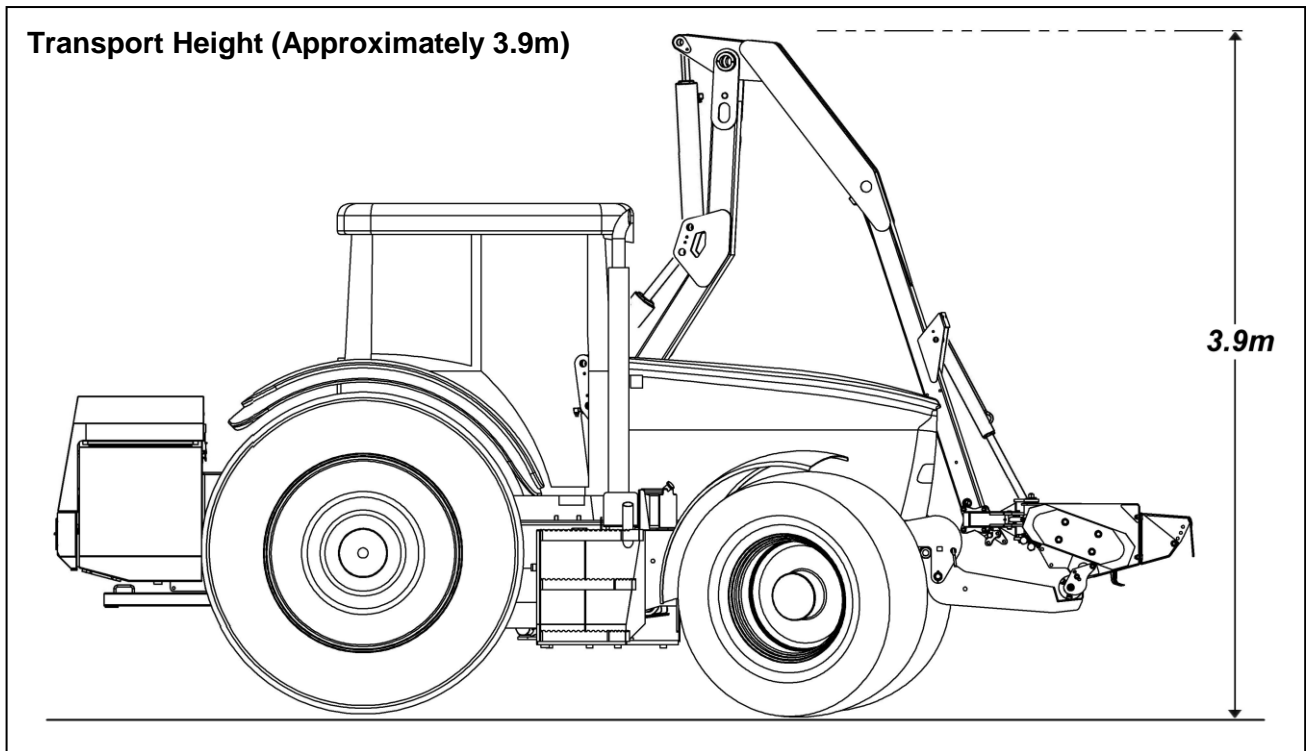

## OVERHEAD POWER LINES (OHPLs)

It cannot be stressed enough the dangers involved when working in the vicinity of Overhead Power Lines (OHPLs). Some of our machines are capable of reach in excess of 8 metres (26'); they have the potential to well exceed, by possibly 3 metres (9' 9"), the lowest legal minimum height of 5.2 metres from the ground for 11,000 and 33,000 volt power lines.

Remember electrocution can occur without actually coming into contact with a power line as electricity can 'flashover' when machinery gets close to it.

**⚠ WARNING** All operators must read the following information and be aware of the risks and dangers involved when working in the vicinity of Overhead Power Lines (OHPLs).

Wherever possible the safest option is always to avoid working in areas close to OHPLs. Where unavoidable, all operators must perform a risk assessment and implement a safe procedure and system of work – see *following page for details*.

All operators should perform a risk assessment before operating the machine within 10m horizontal distance of any OHPLs.

### Minimum Heights for Overhead Power Lines

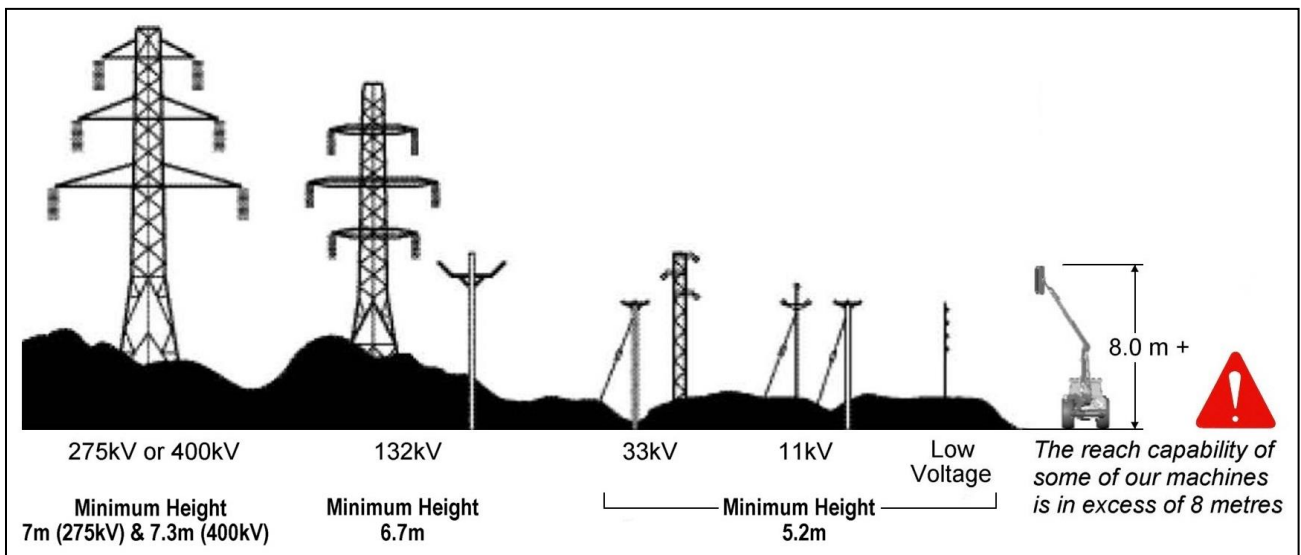

### Absolute Minimum Exclusion Zones for Specific Overhead Power Lines

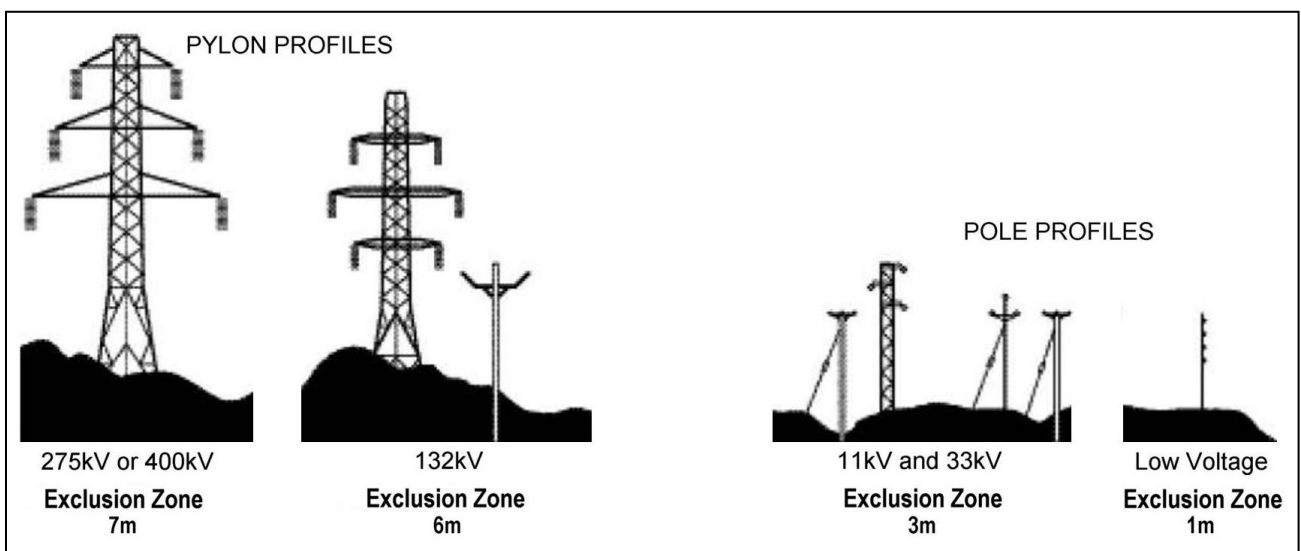



## Definitions of Exclusion Zones

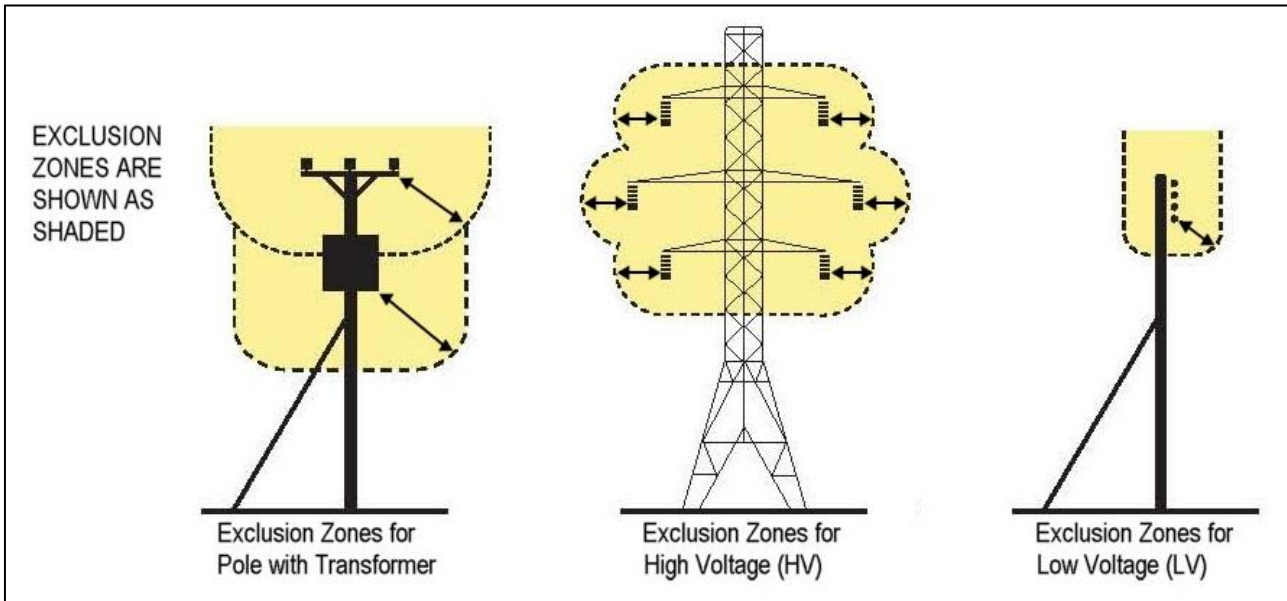

### Risk Assessment

Before starting to work near OHPLs you should always assess the risks. The following points should be observed;

- **Know** the risks of contacting OHPLs and the risk of flashover.
- **Find out** the maximum height and maximum vertical reach of your machine.
- **Find out** the location and route of all Power Lines within the work area.
- **Find out** the operating voltage of all Power Lines within the work area.
- **Contact** the local Distribution Network Operator (DNO) who will be able to advise you on the operating voltage, safe minimum clearance distance for working, and additional precautions required.
- **Never** attempt to operate the machine in exclusion zones.
- **Always** work with extreme caution and plan your work ahead to avoid high risk areas.
- **If doubt exists** do not work in the area – never risk the safety of yourself or others.

### Emergency Action for Accidents Involving Electricity

- Never touch an overhead line - even if it has been brought down by machinery, or has fallen. Never assume lines are dead.
- When a machine is in contact with an overhead line, electrocution is possible if anyone touches both the machine and the ground. Stay in the machine and lower any raised parts in contact or drive the machine out of the lines if you can.
- If you need to get out to summon help or because of fire, jump out as far as you can without touching any wires or the machine - keep upright and away.
- Get the electricity company to disconnect the supply. Even if the line appears dead, do not touch it - automatic switching may reconnect the power.

Further information and leaflets on this and other agricultural safety subjects are available on the 'Health & Safety Executive' website at the following address: [www.hse.gov.uk/pubns/agindex.htm](http://www.hse.gov.uk/pubns/agindex.htm)

## MAINTENANCE - Lubrication

### Arm Unit Lubrication

Lubricate all the greasing points at regular intervals using general-purpose lithium based grease. The diagram below shows the general locations of grease points. Depending on the particular functions built into the specific machine additional greasing points may be present i.e. head rotator unit, head attitude ram etc.

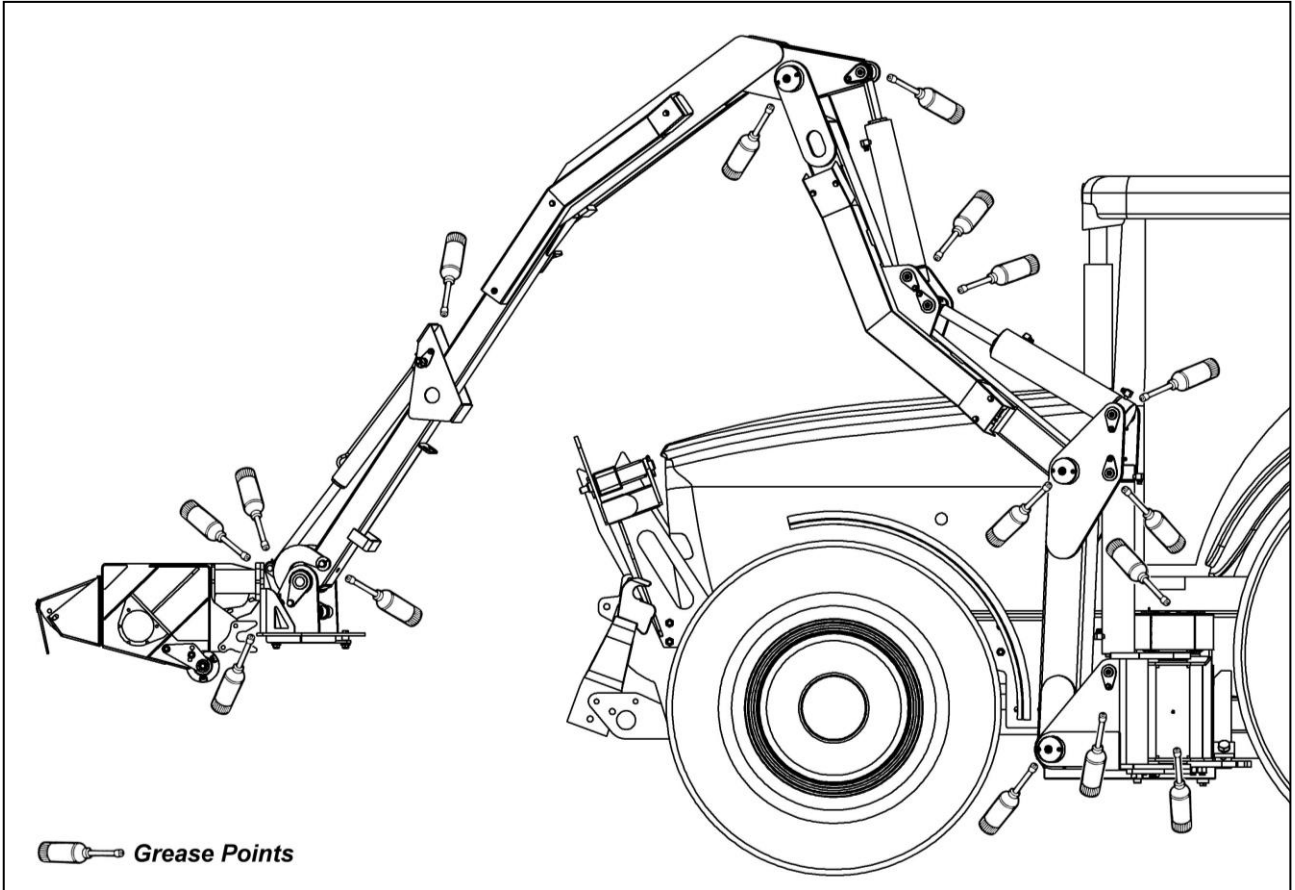

### PTO Shaft Lubrication

Lubricate all points indicated in the diagram below at the intervals stated using general-purpose lithium based grease.

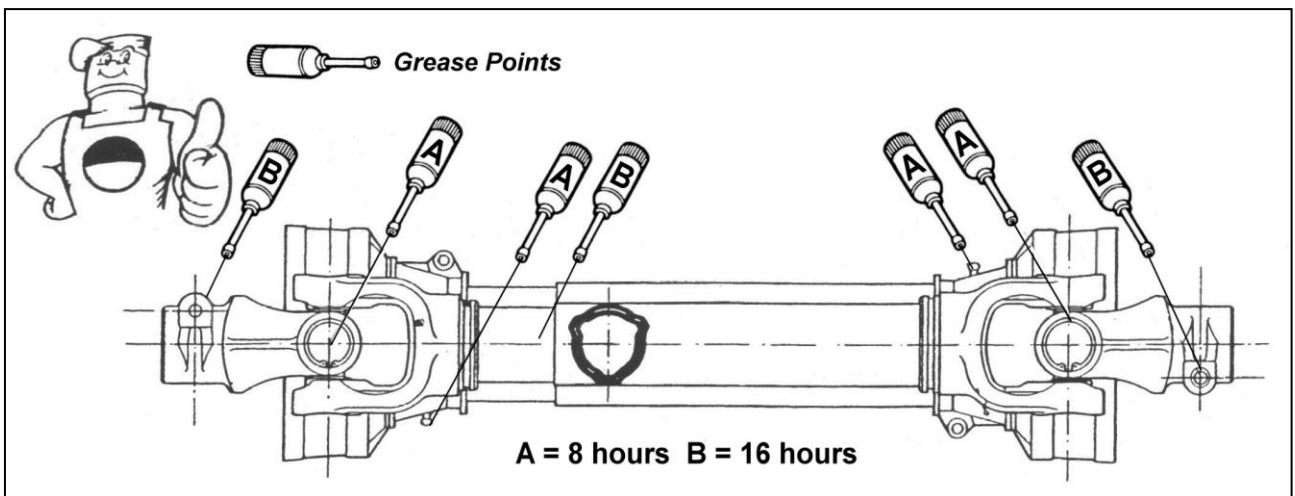

### Gearbox Lubrication

Refill the gearbox with 0.7 Litres of MORRIS FS 75W90 (or an equivalent quality lubricant) after an initial 50 hours of use and thereafter at annual or 500-hour intervals - *whichever occurs earliest*.

## SERVICE SCHEDULE

---

### Every Day

- Grease machine fully prior to work (and prior to storage).  
*NOTE: New machines must be greased before initial use.*
- Check for broken or damaged flails.
- Check tightness of flail nuts and bolts.
- Visually check for oil leaks and damaged hoses.
- Check all guards and safety shields are correctly fitted and undamaged.
- Ensure all lights are working and clean.
- Check oil level.
- Clean the cooler matrix, in dusty conditions more frequent cleaning is required.

### After initial 50 Hours

- Change gearbox oil.

### Every 25 Hours

- Grease PTO Shaft universal joints and tubes.

### Every Week

- Check tightness of all nuts and bolts.
- Check gearbox oil level.
- Check for wear on telescopic arm pads – *where applicable*.

### Every 100 Hours

- Grease PTO shaft shield lubrication points.

### Every 500 Hours

- Change return line filter element (*Every 500 hours or yearly, whichever occurs first*).
- Change gearbox oil.
- Check condition of hydraulic oil and change if required; *when changing oil new return line filter and suction strainer elements should be fitted and return line filter changed again after 100 hours of work.*

### Annually

- Change tank breather.

## MAINTENANCE – Hydraulic System

---

### Oil Supply

Check the oil level in the reservoir daily.

### Oil Condition & Replacement

No fixed time period can be quoted for oil changes as operating conditions can vary widely but a visually inspection of the oil will often indicate its current overall state. Signs of a reduction in its condition will be apparent by changes in colour and appearance when compared to new oil. Oil in poor condition can be dark, smell rancid or burnt, or in some cases be yellow, unclear or milky in appearance indicating the presence of air or emulsified water. Moisture resulting from condensation can become entrapped in the oil causing emulsification that can block the return line filter, consequentially the filter system will be by-passed and the oil and any possible contaminants present will continue to circulate without filtration risking damage to hydraulic components. All are indications or conditions that will require replacement of the oil.

Hydraulic oil is a vital component of the machine; contaminated oil is the root cause of 70% of all hydraulic system failures. Contamination can be reduced by the following;

- *Cleaning around the reservoir cap before removal, and keeping the tank area clean.*
- *Use of clean containers when replenishing the system.*
- *Regular servicing of the filtration system.*

### Filtration System

Machines are protected by both replaceable 125 micron suction strainers and low pressure 10 micron full flow return line filters – the diagram below is a ‘scaled up’ view illustrating the filtering capability built into the hydraulic system of the machine:

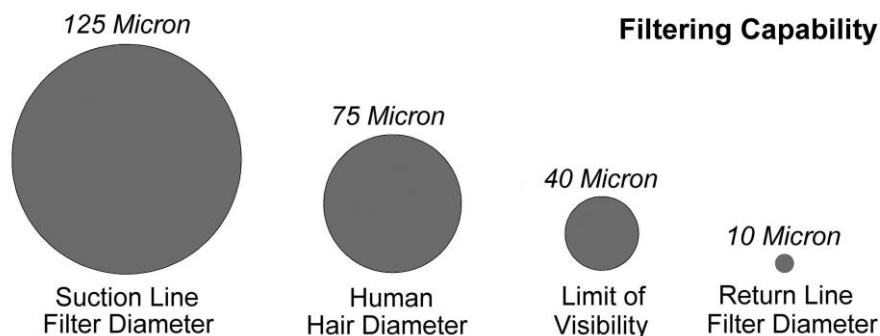

### Suction Strainers

The replaceable 125 micron suction strainers (Part No. 8401097) are fitted within the hydraulic tank and are ‘screw’ fitted with easy access for removal and replacement.

### Return Line Filter

The 10 micron absolute filter elements (Part No. 8401106) should be changed at 500-hour intervals or annually, whichever occurs first. It is important to note hours worked as if the filter becomes blocked an internal by-pass within the canister will operate and no symptoms of filter malfunction will occur to jog your memory.

## HYDRAULIC HOSES

---

The condition of all hoses should be carefully checked during routine service of the machine. Hoses that have been chaffed or damaged on their outer casing should be securely wrapped with waterproof adhesive tape to stop the metal braid from rusting. Hoses that have suffered damage to the metal braid should be changed at the earliest opportunity.

### Hose Replacement

Before changing any hoses take the time to study the existing installation as the routing has been carefully calculated to prevent hose damage during operation - always replace hoses in exactly the same location and manner. This is especially important for the flail hoses where they must be crossed, upper to lower, at the dipper and head pivots.

- Always replace one hose at a time to avoid the risk of wrong connections.
- When the hose is screwed to an additional fitting or union, use a second spanner on the union to avoid breaking both seals.
- Do not use jointing compound on the threads.
- Avoid twisting the hose. Adjust the hose line to ensure freedom from rubbing or trapping before tightening hose end connections.

All Hydraulic Hoses (BSP) now fitted to McConnel Power Arm Hedge/Grass Cutters have 'soft seal' connections on both flail and ram circuit hoses.

Recommended torque settings for nut security are as follows:

SIZE		TORQUE SETTING			O Ring Ref.
1/4" BSP	=	24 Nm	or	18 lb.ft.	10 000 01
3/8" BSP	=	33 Nm	or	24 lb.ft.	10 000 02
1/2" BSP	=	44 Nm	or	35 lb.ft.	10 000 03
5/8" BSP	=	58 Nm	or	43 lb.ft.	10 000 04
3/4" BSP	=	84 Nm	or	62 lb.ft.	10 000 05
1" BSP	=	115 Nm	or	85 lb.ft.	10 000 06

For hose unions (BSP) fitted in conjunction with bonded seals the recommended torque settings are as follows:

SIZE		TORQUE SETTING		
1/4" BSP	=	34 Nm	or	25 lb.ft.
3/8" BSP	=	75 Nm	or	55 lb.ft.
1/2" BSP	=	102 Nm	or	75 lb.ft.
5/8" BSP	=	122 Nm	or	90 lb.ft.
3/4" BSP	=	183 Nm	or	135 lb.ft.
1" BSP	=	203 Nm	or	150 lb.ft.

## NOTICE

**Safety Note:** Soft seal hose connections are capable of holding pressure when the nut is only 'finger tight'. It is therefore recommended during dismantling that the hose be manually flexed to relieve any residual pressure with the retaining nut slackened prior to complete disassembly.



McConnel Limited, Temeside Works, Ludlow, Shropshire SY8 1JL. England.  
Telephone: 01584 873131. Facsimile: 01584 876463. [www.mcconnel.com](http://www.mcconnel.com)